

DESCRIPTION

Demonstration circuit 740 is a tracker/sequencer demo board featuring the LTC2922 that monitors up to five external power supplies and ramps up their load voltages by controlling external N-channel MOS-FETs. Automatic remote sense switching allows supply generators with sense inputs to compensate for voltage drops across the controlling FETs. Excessive current on the primary supply (Supply #0) trips an electronic circuit breaker that will disconnect all of the loads. Four jumpers (block JP1) are provided to select which non-primary supplies are monitored. The resistors that set the supply monitoring levels may be replaced to customize the board for other supply voltage combinations (see the LTC2922 Datasheet). Five other jumpers (blocks JP2, JP3, and JP4) allow the board to demonstrate supply sequencing. With the proper jumper settings, supplies #3 and #4 will

track up together a selectable time after supplies #0, #1, and #2 track up together. The board includes a power-on LED that, when lit, indicates that the primary supply's load is energized. Oversized solder pads under the load resistors and the circuit breaker current sense resistor accommodate a wide range of component footprints. Solder pads on the back of the board accommodate extra load capacitors or resistors. In addition to providing near-by ground connections for each supply input and output, the board has metal ground strips that are convenient clip points for meter leads.

Design files for this circuit board are available. Call the LTC factory.

LTC is a registered trademark of Linear Technology Corporation

Table 1. Performance Summary (T_A = 25°C)

PARAMETER	CONDITION	MIN	TYP	MAX	UNITS
V _{CC} (Supply #0) Voltage Typical Operating Range	Board DC740A-A	4.50	5.00	5.50	V
	Board DC740A-B	2.97	3.30	3.63	V
	Board DC740A-C	2.37	2.50	2.63	V
Load ramp rate	Tracking		0.10		V/ms
	Sequencing, first set of loads		0.10		V/ms
	Sequencing, delayed set of loads		0.12		V/ms
Monitor-to-Tracking Delay	All monitors in compliance to start of GATE ramp		20		ms
Sequencing Delay	Final GATE voltage to start of PG ramp		20		ms
Circuit Breaker Trip Current		3.7	4.2	4.7	A

OPERATING PRINCIPLES

This board may be configured to demonstrate supply tracking or supply sequencing. In tracking mode, all supplies are ramped up simultaneously a selectable delay after all monitoring requirements are met. Supply #0, the V_{CC} supply, is always monitored; monitoring of other supplies is selectable by means of jumper block JP1.

In sequencing mode, the ramping of one set of supplies follows the ramping of another set of supplies. This demonstration board limits the possible delayed supplies to #3 and/or #4. The delayed supplies may not take advantage of automatic remote sense switching.

Table 2. Supply Requirements for Demo Board 740A with Factory Jumper Settings

SUPPLY NUMBER	SUPPLY VOLTAGE	SUPPLY VARIATION	DEMO BOARD VERSION	LOAD CURRENT COMPLIANCE	ADDITIONAL LOAD CURRENT
#0 (Primary Supply = V_{CC} Voltage)	5.0V	±10% max.	740A-A	>95mA	3.7A min. 4.2A typ. 4.7A max.
	3.3V	±10% max.	740A-B	>75mA	
	2.5V	±5% max.	740A-C	>65mA	
#1	2.5V	±7.5% max.	740A-A, -B, -C	>30mA	4.0A max.
#2	1.8V	±7.5% max.	740A-A, -B, -C	>25mA	4.0A max.
#3	1.5V	±7.5% max.	740A-A, -B, -C	>20mA	3.5A max.
#4	1.2V	±5% max.	740A-A, -B, -C	>15mA	3.5A max.

QUICK START PROCEDURE

Demonstration circuit 740 is easy to set up to evaluate the operation of the LTC2922. Refer to Figure 1 for proper measurement equipment setup. To test tracking operation, follow steps 1 through 3 below, then proceed to step 7. To test sequencing operation, follow steps 4 through 6, then proceed to step 7.

Use of remote sense switching is optional on a per supply basis (see Figure 1). It is available for all supplies in tracking applications, but only for supplies 0 through 2 in sequencing applications.

The demo board is shipped with the jumpers set for monitoring all five supplies and tracking of all the loads. In addition, a resistor pull-up to V_{CC} from the PG pin makes the power good output a proper logic signal.

The voltage and current requirements for supply generators when the board has factory jumper settings, and the factory installed values for monitoring resistors RA1-RA4 and RB1-RB4 are summarized in Table 2. Consult the LTC2922 Datasheet to calculate new resistor values to monitor supplies with different voltages or tolerances.

External loads may be added at the load terminals. Make the wires as short as possible to reduce inductance and resistance, and use a gauge proper for the expected load currents.

TRACKING

- Set the jumpers of block JP1 to choose which supplies, in addition to the primary supply, will be monitored. For example, to monitor all supplies set:

JP1 Supply#1 Monitor

JP1 Supply#2 Monitor

JP1 Supply#3 Monitor

JP1 Supply#4 Monitor

- Set jumper JP2 to select the resistive pull-up on the PG pin:

JP2 PG Function Pull-up

- Set the upper and lower jumpers of blocks JP3 and JP4 to select tracking and automatic remote sense switching:

JP3 Load#3 Track

JP3 Load#3 Remote Sense

JP4 Load#4 Track

JP4 Load#4 Remote Sense

NOTE: Remote sense switching will have no effect if supply generators' sense inputs are not connected to the board's FB turret posts.

Proceed to step 7.

SEQUENCING

4. Set the jumpers of block JP1 to choose which supplies, in addition to the primary supply, will be monitored. For example, to monitor all supplies, set:

JP1 Supply#1 Monitor

JP1 Supply#2 Monitor

JP1 Supply#3 Monitor

JP1 Supply#4 Monitor

5. Set jumper JP2 to select the sequencing function of the PG pin:

JP2 PG Function Sequence

6. Set the upper and lower jumpers of blocks JP3 and JP4 to choose which supplies get a sequencing delay. For example, to sequence both supply #3 and supply #4, set:

JP3 Load#3 Sequence

JP3 Load#3 Sequence/No Sense

JP4 Load#4 Sequence

JP4 Load#4 Sequence/No Sense

NOTE: When a supply is sequenced, remote sense switching is not available for that supply.

7. With the power off, connect supply generators to the Supply and GND terminal pairs on the left side of the board. Connect sense terminals of the sup-

ply generators (if available) to the FB terminals on the left side of the board.

8. Leave one supply off, turn on all the other supplies. This supply must be selected as a monitored supply, and should be the trigger signal for the oscilloscope.
9. Turn on the final supply and capture selected supply voltage and load voltage waveforms.
10. Make sure that the Load #0 Power On indicator LED is lighted, and that the load voltages nearly equal the supply voltages. (Small differences will occur due to the voltage drop across the controlling FETs.)

NOTE: If the loads do not power up, double check the voltage levels and current compliances of the supplies against the required values in Table 2.

11. When the load voltages have successfully ramped, view the scope trace to measure the monitor-to-ramp start delay, the supply ramp rate, and other parameters in Table 1. Note the compensating effect of automatic remote sense switching if supply sense inputs are connected.
12. Check the operation of the electronic circuit breaker by loading the primary supply and noting the disconnection of all supplies. Pulse supply #1 low or short pin "V1 In" to ground momentarily to reset the breaker and initiate tracking or sequencing.

QUICK START GUIDE FOR DEMONSTRATION CIRCUIT 740 TRACKER/SEQUENCER DEMO BOARD

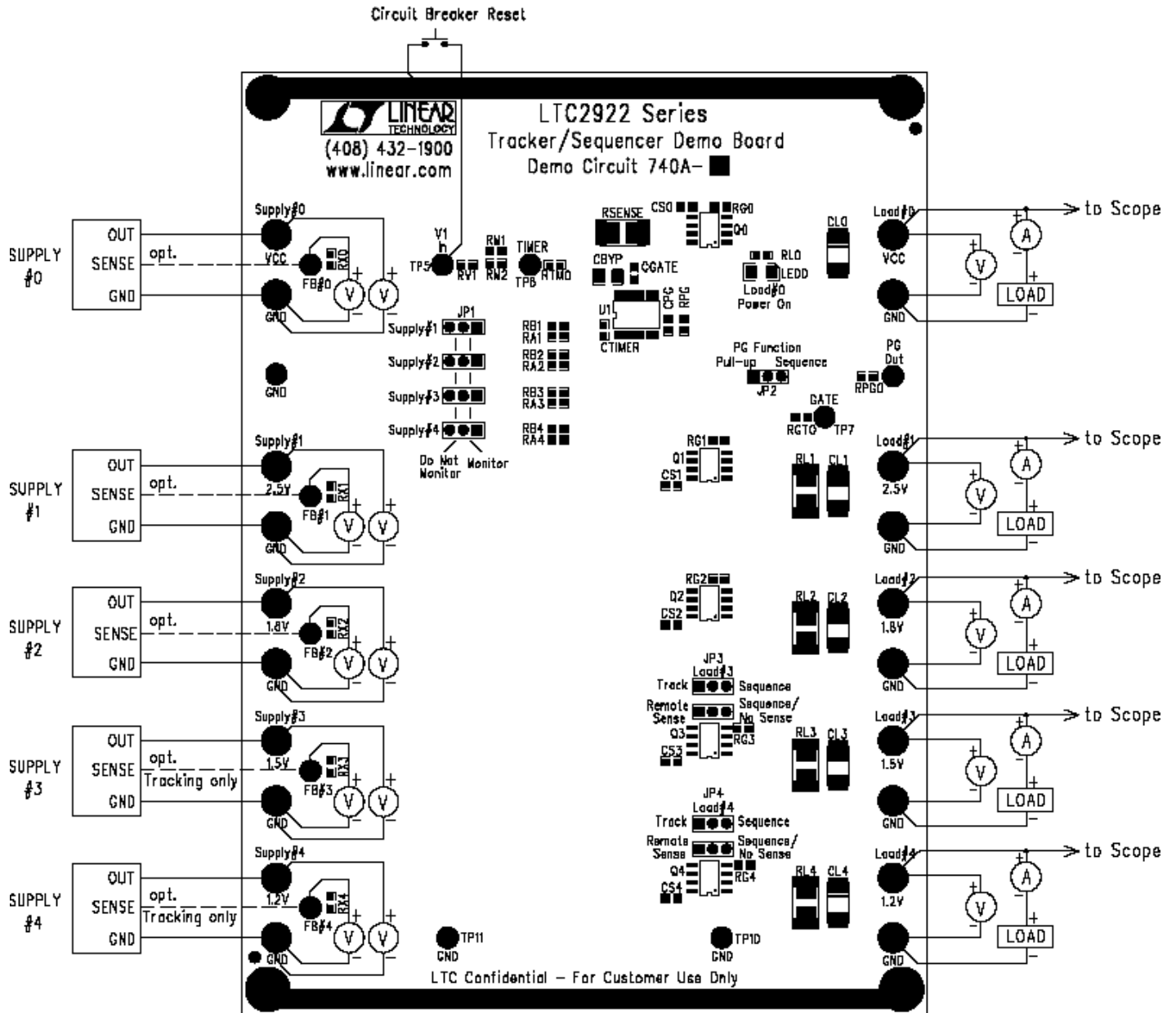
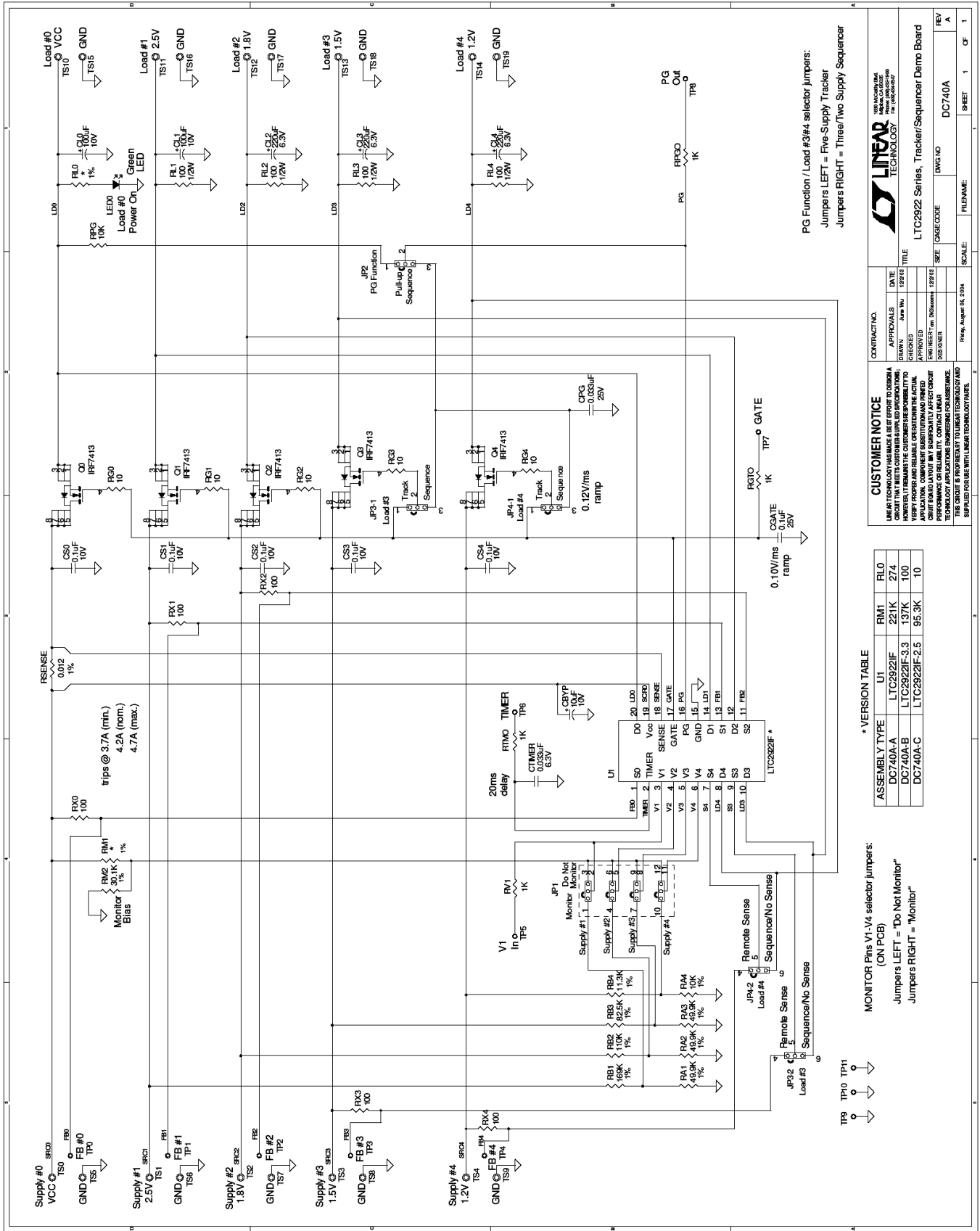

Figure 1. Proper Measurement Equipment Setup

QUICK START GUIDE FOR DEMONSTRATION CIRCUIT 740 TRACKER/SEQUENCER DEMO BOARD



PG Function / Load #3#4 selector jumpers:
 Jumpers LEFT = Five-Supply Tracker
 Jumpers RIGHT = Three/Two Supply Sequencer

CONTRACT NO.		DATE	
APPROVALS	DATE	APPROVALS	DATE
DRAWN	JAN 04 12:45	CHECKED	JAN 04 12:45
DESIGNED		APPROVED	
ENGINEER	Tom_Kilbourne	DESIGNER	12/12
SCALE	1:1	SCALE	1:1
FILENAME	DC740A	SHEET	1 of 1

CUSTOMER NOTICE
 LINEAR TECHNOLOGY HAS MADE A BEST EFFORT TO DESIGN A CIRCUIT THAT MEETS CUSTOMER'S SPECIFICATIONS. HOWEVER, WE DO NOT WARRANT THE PERFORMANCE OF THE CIRCUIT UNDER ANY CONDITIONS. CUSTOMER'S APPLICATION, COMPONENT SUBSTITUTION AND PREVIOUS BOARD HISTORY MAY AFFECT THE PERFORMANCE OF THE CIRCUIT. LINEAR TECHNOLOGY ASSUMES NO LIABILITY FOR THE BOARD'S PERFORMANCE UNDER ANY CONDITIONS. THE CIRCUIT IS PROPRIETARY TO LINEAR TECHNOLOGY AND IS SUPPLIED FOR USE WITH LINEAR TECHNOLOGY PARTS.

*** VERSION TABLE**

ASSEMBLY TYPE	UI	RM1	RL0
DC740A-A	LTC2922IF	221K	274
DC740A-B	LTC2922IF-3.3	137K	100
DC740A-C	LTC2922IF-2.5	95.3K	10

MONITOR Pins V1, V4 selector jumpers:
 (ON PCB)
 Jumpers LEFT = "Do Not Monitor"
 Jumpers RIGHT = "Monitor"

Компания «Океан Электроники» предлагает заключение долгосрочных отношений при поставках импортных электронных компонентов на взаимовыгодных условиях!

Наши преимущества:

- Поставка оригинальных импортных электронных компонентов напрямую с производств Америки, Европы и Азии, а так же с крупнейших складов мира;
- Широкая линейка поставок активных и пассивных импортных электронных компонентов (более 30 млн. наименований);
- Поставка сложных, дефицитных, либо снятых с производства позиций;
- Оперативные сроки поставки под заказ (от 5 рабочих дней);
- Экспресс доставка в любую точку России;
- Помощь Конструкторского Отдела и консультации квалифицированных инженеров;
- Техническая поддержка проекта, помощь в подборе аналогов, поставка прототипов;
- Поставка электронных компонентов под контролем ВП;
- Система менеджмента качества сертифицирована по Международному стандарту ISO 9001;
- При необходимости вся продукция военного и аэрокосмического назначения проходит испытания и сертификацию в лаборатории (по согласованию с заказчиком);
- Поставка специализированных компонентов военного и аэрокосмического уровня качества (Xilinx, Altera, Analog Devices, Intersil, Interpoint, Microsemi, Actel, Aeroflex, Peregrine, VPT, Syfer, Eurofarad, Texas Instruments, MS Kennedy, Miteq, Cobham, E2V, MA-COM, Hittite, Mini-Circuits, General Dynamics и др.);

Компания «Океан Электроники» является официальным дистрибьютором и эксклюзивным представителем в России одного из крупнейших производителей разъемов военного и аэрокосмического назначения «JONHON», а так же официальным дистрибьютором и эксклюзивным представителем в России производителя высокотехнологичных и надежных решений для передачи СВЧ сигналов «FORSTAR».



JONHON

«JONHON» (основан в 1970 г.)

Разъемы специального, военного и аэрокосмического назначения:

(Применяются в военной, авиационной, аэрокосмической, морской, железнодорожной, горно- и нефтедобывающей отраслях промышленности)

«FORSTAR» (основан в 1998 г.)

ВЧ соединители, коаксиальные кабели, кабельные сборки и микроволновые компоненты:

(Применяются в телекоммуникациях гражданского и специального назначения, в средствах связи, РЛС, а так же военной, авиационной и аэрокосмической отраслях промышленности).



Телефон: 8 (812) 309-75-97 (многоканальный)

Факс: 8 (812) 320-03-32

Электронная почта: ocean@oceanchips.ru

Web: <http://oceanchips.ru/>

Адрес: 198099, г. Санкт-Петербург, ул. Калинина, д. 2, корп. 4, лит. А