

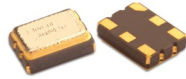

PLETRONICS LV44J Series 3.3V LVDS Clock Oscillator



LV44JW
3.20 x 2.50 x 1.00 mm
LCC Ceramic Package

Features

- Pletronics' LV44J Series is a Quartz crystal controlled Precision Square Wave Oscillator
- LVDS Output
- Enable/Disable Function on pad 1
- Low Jitter
- 3.3V nominal Supply Voltage
- 25-175 MHz Frequency Range

Applications

Driving A/Ds, D/As, FPGAs
Fibre Channel
Ethernet, GbE, SynchE
Medical
Storage Area Networking
COTS
Telecom
PON

Electrical Characteristics

Parameter	Min	Typ	Max	Unit	Condition
Frequency Range ²	25	-	175	MHz	Consult factory for other options
Frequency Stability vs. Temperature ² ± 20 = 20 , ± 25 = 44 , ± 50 = 45	-20	-	+50	ppm	For all supply voltages, load changes, aging for 1 year at 25°C ± 2°C, shock, vibration and temperatures
Operating Temperature Range ²	-10 -20 -40	-	+70 +70 +85	°C	Standard range Extended range C option Extended range E option
Supply Voltage ^{1,2} V _{CC}	-	3.30	-	Volts	± 5%
Supply Current I _{CC}	-	-	39	mA	
Output Waveform	LVDS				
Output High Level V _{OH}	-	-	1.6	Volts	See Load Circuit R = 50 ohms
Output Low Level V _{OL}	0.9	-	-	Volts	
Differential Output Voltage V _{OD}	247	-	454	mVolts	
Output Offset Voltage V _{OS}	1.125	-	1.375	Volts	
Differential Output Error ΔV _{OD}	-	-	50	mVolts	
Output T _{RISE} and T _{FALL}	-	-	0.4	ns	V _{th} is 20% and 80% of waveform
Startup Time	-	-	10	ms	Time for output to reach specified frequency
Duty Cycle	45	-	55	%	Referenced to 50% if amplitude or crossing point
V _{DISABLE}	-	-	30	%V _{CC}	Referenced to Ground
V _{ENABLE}	70	-	-		
Enable Time	-	-	10	ms	Time for output to reach a logic state
Disable Time	-	-	200	ns	Time for output to reach a high Z state
Enable/Disable Internal Pull-up	30	-	150	Kohm	To V _{CC} , measured with pad 1 = 0.0 volts
Output Leakage	V _{OUT} = V _{CC} V _{OUT} = 0V	-10 -10	+10 +10	μA	Pad 1 low, device disabled
Standby Current	-	-	15	μA	
Jitter	-	0.1	-	pS	12 kHz to 20 MHz from the output frequency at 156.25 MHz
Phase Noise	10 Hz 100 Hz 1 kHz 10 kHz 100 kHz	- -64 -98 -127 -142 -152	-	dBc/Hz	25°C ± 2°C at 156.25 MHz
Storage Temperature Range	-55	-	+125	°C	

Notes: Specifications with Pad 1 E/D open circuit

¹ Place an appropriate power supply bypass capacitor next to device for correct operation

² Specified by part number



PLETRONICS LV44J Series 3.3V LVDS Clock Oscillator

Part Number

Series Model	Frequency Stability		Operating Temperature Range	Supply Voltage V _{CC}	Frequency in MHz	Optional T&R Packaging code
LV44	45	J	E	V	- 100.0M	-XX
	45 = ± 50 ppm (STD) 44 = ± 25 ppm 20 = ± 20 ppm		Blank = -10 to +70°C (STD) C = -20 to +70°C E = -40 to +85°C	V = 3.3V±5%	25-175 MHz	T250 = 250 per Reel T500 = 500 per Reel T1K = 1000 per Reel (Std for 1K pcs)

Device Marking

PFF.FF L
• **YMDxxx**

P = Pletronics
FFF.FF L = Frequency in MHz, L for LVDS
YMD = Date Code, All other marking is internal codes

Note: Specifications such as frequency stability, supply voltage and operating temperature range, etc. are not identified from marking. External packaging labels and packing list will correctly identify the ordered Pletronics part number.

Codes for Date Code YMD (Year Month Day)

Code	7	8	9	0	1	Code	A	B	C	D	E	F	G	H	J	K	L	M
Year	2017	2018	2019	2020	2021	Month	JAN	FEB	MAR	APR	MAY	JUN	JUL	AUG	SEP	OCT	NOV	DEC

Code	1	2	3	4	5	6	7	8	9	A	B	C	D	E	F	G
Day	1	2	3	4	5	6	7	8	9	10	11	12	13	14	15	16
Code	H	J	K	L	M	N	P	R	T	U	V	W	X	Y	Z	
Day	17	18	19	20	21	22	23	24	25	26	27	28	29	30	31	

Package Labeling

Tape and Reel available for quantities of 250 to 1000 per reel, cut tape for < 250. 16mm tape, 8mm pitch.

P/N Label is 1" x 2.6" (25.4mm x 66.7mm)
Font is Courier New
Bar code is 39-Full ASCII

RoHS Label is 1" x 2.6" (25.4mm x 66.7mm)
Font is Arial

P/N:	
	LV4445JEV-100.0M
Customer P/N:	
	12345678
Qty:	
	1000
D/C	
	9DW
MSL: 1	

RoHS Compliant
2nd Lvl Interconnect
Category=e4
Max Safe Temp=260C for 10s 2X Max

Pletronics Inc. certifies this device is in accordance with the RoHS 3 (2015/863) and WEEE 2 (2012/19/EU) directives.

Pletronics Inc. guarantees the device does not contain the following: Cadmium, Hexavalent Chromium, Lead, Mercury, PBB's, PBDE's
Weight of the Device: 0.041 grams
Moisture Sensitivity Level: 1 As defined in J-STD-020D
Second Level Interconnect code: e4



PLETRONICS LV44J Series 3.3V LVDS Clock Oscillator

Mechanical Dimensions

	Inches	mm
A	0.126 ± 0.008	3.20 ± 0.20
B	0.098 ± 0.008	2.50 ± 0.20
C	0.035 ± 0.004	0.9 ± 0.10
D ¹	0.063	1.60
E ¹	0.051	1.30
F ¹	0.024	0.60
G ¹	0.024	0.60
H ¹	0.031	0.80

¹ Typical dimensions

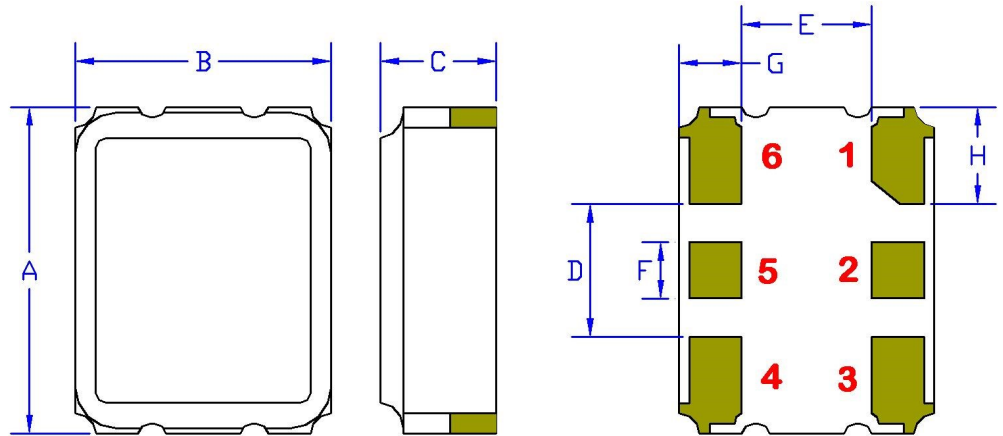

Pad Layout mm shown

Disclaimer: Recommended layout shown.
Adjust layout as needed for individual
process requirements.

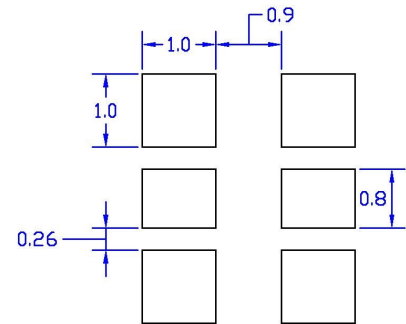

(Not to Scale)

Contacts (pads): Gold 11.8 to 39.4 μinches (0.3 to 1.0 μm) over Nickel 50 to 350 μinches (1.27 to 8.89 μm)

Layout

Pad	Function	Note
1	Output Enable/Disable	The oscillator shall operate when this pad is not connected. The output will be inhibited (high impedance state) when this pad is logic low. Recommend connecting this pad to V _{CC} if the oscillator is to be always on.
2	No connect	There is no internal connection to this pad. Recommend connecting to pad 1 to permit E/D input on either pad for layout.
3	Ground (GND)	
4	Output	Both outputs must be terminated and biased for proper operation.
5	Output*	The ideal termination is 100 ohms between the outputs
6	V _{CC} Supply Voltage	Connect an appropriate power supply bypass capacitor as close as possible to pad 4

For Optimum Jitter Performance, Pletronics recommends:

- A ground plane under the device
- Do not route large transient signals (both current and voltage) under the device
- Do not place near a large magnetic field such as a high frequency switching power supply
- Do not place near piezoelectric buzzers or mechanical fans

Electrical Test /Load Circuit

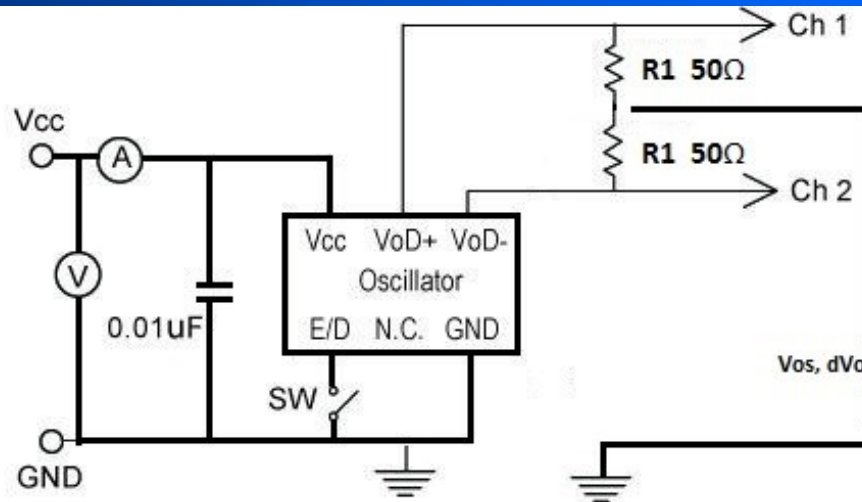

Test Waveform

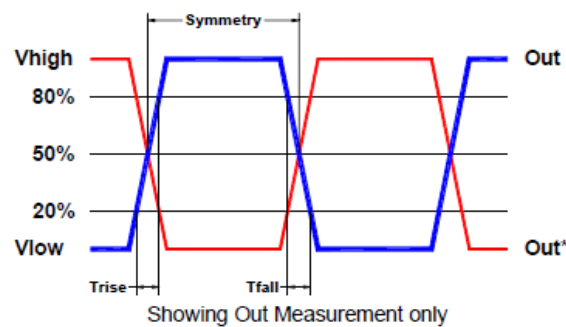

Environmental / ESD Ratings

Reliability: Environmental Compliance

Parameter	Condition
Mechanical Shock	JESD22-B104
Vibration	JESD22-B103
Solderability	IPC J-STD-002
Thermal Shock	MIL-STD-883 Method 1011, Condition A

ESD Rating

Model	Min. Voltage	Condition
Human Body Model	2000V	JESD22-A114
Charged Device Model	500V	JESD 22-C101
Machine Model	200V	JESD22-A115

Absolute Maximum Ratings

Parameter	Unit
V _{CC} Supply Voltage	-0.5V to +5.0V
V _i Input Voltage	-0.5V to V _{CC} + 0.5V
V _o Output Voltage	-0.5V to V _{CC} + 0.5V

Thermal Characteristics:

The maximum die or junction temperature is 155°C
The thermal resistance junction to board is 45 to 65°C/Watt depending on the solder pads, ground plane and construction of the PCB.



PLETRONICS LV44J Series 3.3V LVDS Clock Oscillator

Reflow Cycle

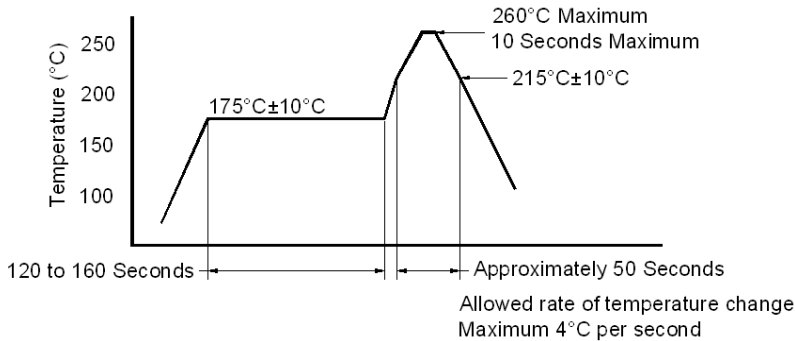

The part may be reflowed 2 times without degradation (typical for lead free processing).

Tape and Reel

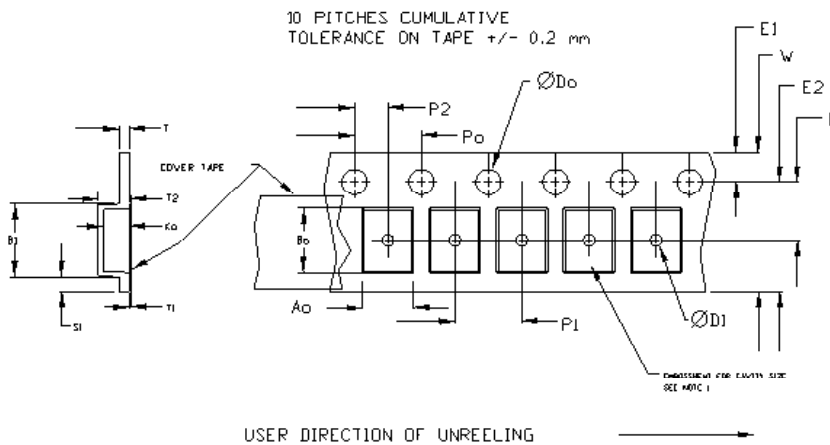

Tape Constant Dimensions Table 1

Tape Size	Do	D1 min	E1	Po	P2	S1 min	T max	T1 max
8mm	1.5	1.0	1.75	4.0	2.0	0.6	0.6	0.1
12mm		1.5			±0.05			
16mm	+0.1 -0.0	1.5	±0.1	±0.1	2.0			
24mm		1.5			±0.1			

Tape Variable Dimensions Table 2

Tape Size	B1 max	E2 min	F	P1	T2 max	W max	Ao, Bo & Ko
16mm	12.1	14.25	7.5 ±0.1	8.0 ±0.1	8.0	16.3	Note 1

Dimensions in mm Drawing Not to scale

Note 1: Embossed cavity to conform to EIA-481-B

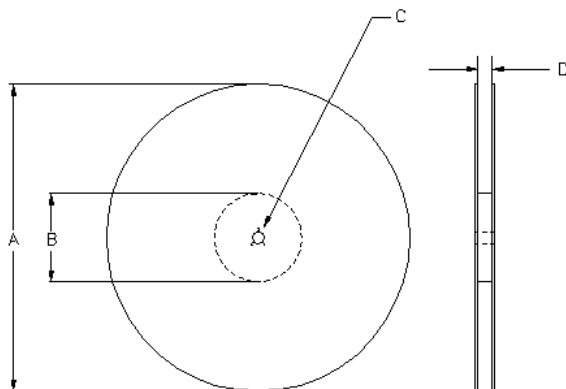

Reel Dimensions (may vary) Table 3

Reel Size	A		B		C	D
	Inches	mm	Inches	mm		
7	7.0	177.8	2.50	63.5	13.0	Tape size +0.4
10	10.0	254.0	4.00	101.6		
13	13.0	330.2	3.75	95.3	+0.5 -0.2	+2.0 -0.0



PLETRONICS LV44J Series 3.3V LVDS Clock Oscillator

Important Notice

Pletronics Incorporated (PLE) reserves the right to make corrections, improvements, modifications and other changes to this product at anytime. PLE reserves the right to discontinue any product or service without notice. Customers are responsible for obtaining the latest relevant information before placing orders and should verify that such information is current and complete. All products are sold subject to PLE's terms and conditions of sale supplied at the time of order acknowledgment.

PLE warrants performance of this product to the specifications applicable at the time of sale in accordance with PLE's limited warranty. Testing and other quality control techniques are used to the extent PLE deems necessary to support this warranty. Except where mandated by specific contractual documents, testing of all parameters of each product is not necessarily performed.

PLE assumes no liability for application assistance or customer product design. Customers are responsible for their products and applications using PLE components. To minimize the risks associated with the customer products and applications, customers should provide adequate design and operating safeguards.

PLE products are not designed, intended, authorized or warranted to be suitable for use in life support applications, weapons, weapon systems or space applications, devices or systems or other critical applications that may involve potential risks of death, personal injury or severe property or environmental damage. Inclusion of PLE products in such applications is understood to be fully at the risk of the customer. Use of PLE products in such applications requires the written approval of an appropriate PLE officer. Questions concerning potential risk applications should be directed to PLE.

PLE does not warrant or represent that any license, either express or implied, is granted under any PLE patent right, copyright, artwork or other intellectual property right relating to any combination, machine or process which PLE product or services are used. Information published by PLE regarding third-party products or services does not constitute a license from PLE to use such products or services or a warranty or endorsement thereof. Use of such information may require a license from a third party under the patents or other intellectual property of the third party, or a license from PLE under the patents or other intellectual property of PLE.

Reproduction of information in PLE data sheets or web site is permissible only if the reproduction is without alteration and is accompanied by associated warranties, conditions, limitations and notices. Reproduction of this information with alteration is an unfair and deceptive business practice. PLE is not responsible or liable for such altered documents.

Resale of PLE products or services with statements different from or beyond the parameters stated by PLE for that product or service voids all express and implied warranties for the associated PLE product or service and is an unfair or deceptive business practice. PLE is not responsible for any such statements.

Contacting Pletronics Inc.

Pletronics, Inc.
19013 36th Ave. West
Lynnwood, WA 98036-5761
U.S.A.

Tel: 425.776.1880
Fax: 425.776.2760
email: ple-sales@pletronics.com

URL: www.pletronics.com

Компания «Океан Электроники» предлагает заключение долгосрочных отношений при поставках импортных электронных компонентов на взаимовыгодных условиях!

Наши преимущества:

- Поставка оригинальных импортных электронных компонентов напрямую с производств Америки, Европы и Азии, а так же с крупнейших складов мира;
- Широкая линейка поставок активных и пассивных импортных электронных компонентов (более 30 млн. наименований);
- Поставка сложных, дефицитных, либо снятых с производства позиций;
- Оперативные сроки поставки под заказ (от 5 рабочих дней);
- Экспресс доставка в любую точку России;
- Помощь Конструкторского Отдела и консультации квалифицированных инженеров;
- Техническая поддержка проекта, помощь в подборе аналогов, поставка прототипов;
- Поставка электронных компонентов под контролем ВП;
- Система менеджмента качества сертифицирована по Международному стандарту ISO 9001;
- При необходимости вся продукция военного и аэрокосмического назначения проходит испытания и сертификацию в лаборатории (по согласованию с заказчиком);
- Поставка специализированных компонентов военного и аэрокосмического уровня качества (Xilinx, Altera, Analog Devices, Intersil, Interpoint, Microsemi, Actel, Aeroflex, Peregrine, VPT, Syfer, Eurofarad, Texas Instruments, MS Kennedy, Miteq, Cobham, E2V, MA-COM, Hittite, Mini-Circuits, General Dynamics и др.);

Компания «Океан Электроники» является официальным дистрибьютором и эксклюзивным представителем в России одного из крупнейших производителей разъемов военного и аэрокосмического назначения «**JONHON**», а так же официальным дистрибьютором и эксклюзивным представителем в России производителя высокотехнологичных и надежных решений для передачи СВЧ сигналов «**FORSTAR**».



JONHON

«**JONHON**» (основан в 1970 г.)

Разъемы специального, военного и аэрокосмического назначения:

(Применяются в военной, авиационной, аэрокосмической, морской, железнодорожной, горно- и нефтедобывающей отраслях промышленности)

«**FORSTAR**» (основан в 1998 г.)

ВЧ соединители, коаксиальные кабели,
кабельные сборки и микроволновые компоненты:

(Применяются в телекоммуникациях гражданского и специального назначения, в средствах связи, РЛС, а так же военной, авиационной и аэрокосмической отраслях промышленности).



Телефон: 8 (812) 309-75-97 (многоканальный)

Факс: 8 (812) 320-03-32

Электронная почта: ocean@oceanchips.ru

Web: <http://oceanchips.ru/>

Адрес: 198099, г. Санкт-Петербург, ул. Калинина, д. 2, корп. 4, лит. А