

## FEATURES

**56 MSPS correlated double sampler (CDS) with 6 dB gain**  
**On-chip horizontal and RG timing driver**  
**Single-supply operation (2.7 V min)**  
**Precision Timing™ core with 0.37 ns resolution at 56 MSPS**  
**Low power CMOS: 105 mW at 2.7 V (115 mW at 3.0 V)**  
**48-lead LQFP and 48-lead LFCSP packages**

## APPLICATIONS

**Professional HDTV camcorders**  
**Professional/high end digital cameras**  
**Broadcast cameras**  
**Industrial high speed cameras**  
**High speed data-acquisition systems**

## GENERAL DESCRIPTION

The AD9940 is a high speed, correlated double sampler for high speed digital imaging applications. Integrated with a programmable timing driver using the *Precision Timing* core, the AD9940 features a 56 MHz CDS amplifier with 6 dB of fixed gain, an internal voltage reference supply, and timing control for all the high speed clocks necessary for CCD imaging systems. The Precision Timing core allows adjustment of high speed clocks with a resolution of 0.37 ns. Output buffers are also included, providing drive strength for PCB traces and direct connection to an image signal processor such as the AD9941.

The AD9940 is ideal for applications that need to place the CDS and VGA/ADC circuits on separate PC boards. The fully differential outputs of the AD9940 provide good signal integrity when interfaced with the differential input AD9941. The AD9940 operates from a single 2.7 V power supply, typically dissipates 105 mW (excluding the H/RG drive current), and is packaged in 48-lead LQFP and 48-lead LFCSP packages.

## FUNCTIONAL BLOCK DIAGRAM

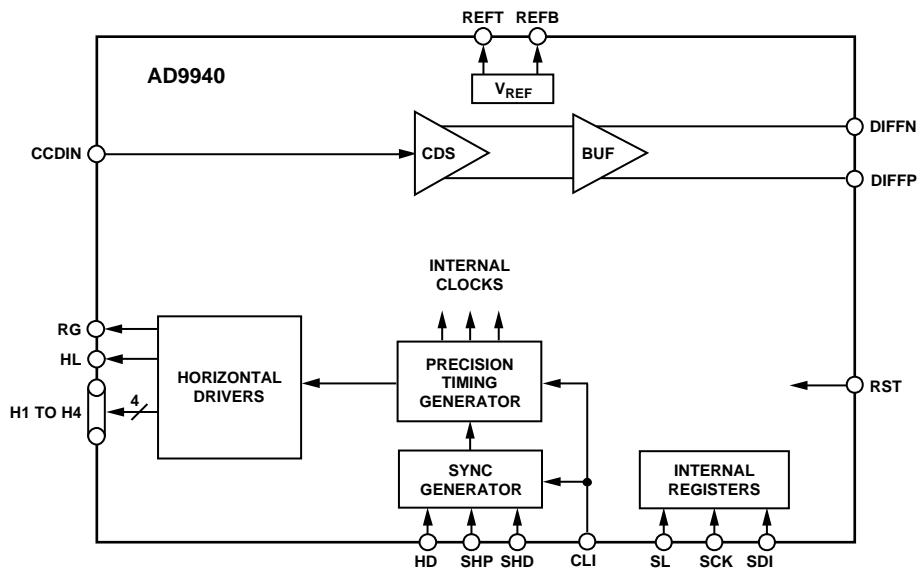

Figure 1.

Rev. A

[Document Feedback](#)

Information furnished by Analog Devices is believed to be accurate and reliable. However, no responsibility is assumed by Analog Devices for its use, nor for any infringements of patents or other rights of third parties that may result from its use. Specifications subject to change without notice. No license is granted by implication or otherwise under any patent or patent rights of Analog Devices. Trademarks and registered trademarks are the property of their respective owners.

One Technology Way, P.O. Box 9106, Norwood, MA 02062-9106, U.S.A.  
 Tel: 781.329.4700 ©2005–2016 Analog Devices, Inc. All rights reserved.  
[Technical Support](#) [www.analog.com](http://www.analog.com)

## TABLE OF CONTENTS

Features .....	1	Data Bit Descriptions.....	9
Applications.....	1	Serial Interface Timing .....	12
General Description .....	1	System Overview .....	13
Functional Block Diagram .....	1	Analog Front End Operation.....	13
Revision History .....	2	Precision Timing, High Speed Timing Generation.....	14
Specifications.....	3	Timing Resolution.....	14
Analog Specifications.....	4	High Speed Clock Programmability.....	14
Digital Specifications .....	5	H-Driver and RG Outputs .....	16
Timing Specifications (Slave Timing Mode) .....	5	HBLK Sequences .....	17
Absolute Maximum Ratings.....	6	Applications Information .....	19
Thermal Characteristics .....	6	Outline Dimensions .....	20
ESD Caution.....	6	Ordering Guide .....	20
Pin Configuration and Function Descriptions.....	7		

## REVISION HISTORY

### 9/2016—Rev. 0 to Rev. A

Changes to Figure 4.....	7
Changes to Table 6.....	8
Change to Figure 15 Caption .....	19
Updated Outline Dimensions .....	20
Changes to Ordering Guide .....	20

### 7/2005—Revision 0: Initial Version

## SPECIFICATIONS

Table 1.

Parameter	Min	Typ	Max	Unit
TEMPERATURE RANGE				
Operating	-25		+85	°C
Storage	-65		+150	°C
MAXIMUM CLOCK RATE	56			MHz
POWER SUPPLY VOLTAGE				
AVDD, TCVD (AFE, Timing Core)	2.7	3.0	3.6	V
OVDD (Analog Buffer)	2.7	3.0	3.6	V
DVDD (Digital)	2.7	3.0	3.6	V
HVDD (H1 to H4 Drivers)	2.7	3.0	3.6	V
RGVDD (RG Driver)	2.7	3.0	3.6	V
POWER DISSIPATION <sup>1</sup>				
56 MHz, AFE supplies = 2.7 V, HVDD = RGVDD = 3.2 V, 70 pF, H1 to H4 Loading		265		mW
56 MHz, AFE supplies = 3.0 V, HVDD = RGVDD = 3.2 V, 70 pF, H1 to H4 Loading		275		mW
56 MHz, AFE supplies = 2.7 V, no H or RG drivers		105		mW
56 MHz, AFE supplies = 3.0 V, no H or RG drivers		115		mW
Standby Mode		2		mW

<sup>1</sup> The total power dissipated by the HVDD supply can be approximated using the following equation:

$$\text{Total HVDD Power} = (C_{\text{LOAD}} \times \text{HVDD} \times \text{Pixel Frequency}) \times \text{HVDD}$$

Reducing the H-loading and/or using a lower HVDD supply reduces the power dissipation.

## ANALOG SPECIFICATIONS

$f_{CL1} = 56 \text{ MHz}$ ,  $AVDD = OVDD = DVDD = TCVD = 3.0 \text{ V}$ ,  $-25^\circ\text{C}$  to  $+85^\circ\text{C}$ , unless otherwise noted.

Table 2.

Parameter	Min	Typ	Max	Unit	Notes
CDS					
Gain	5.0	5.5	6.0	dB	
Allowable CCD Reset Transient <sup>1</sup>		500		mV	
Maximum Input Range Before Saturation <sup>1</sup>		1		V p-p	
Maximum CCD Black Pixel Amplitude <sup>1</sup>		$\pm 50$		mV	
Peak Nonlinearity, 500 mV Input Signal		0.2		% FS	
Power Supply Rejection (PSR)		36		dB	Measured with step change on supply
ANALOG OUTPUTS <sup>2</sup>					
Typical DIFFP Output Signal Range	1.2		2.2	V	1.2 V corresponds to black level
Typical DIFFN Output Signal Range	1.2		2.2	V	2.2 V corresponds to black level
Typical Common Mode Level		1.7		V	Midscale voltage where DIFFP = DIFFN
Maximum Differential Output Voltage Swing		2		V	Defined as DIFFP – DIFFN
Output Voltage Compliance	1.0		2.4	V	Limitation of output swing into external load
Maximum Load Capacitance		24		pF	Value for each output (AD9941 $C_{IN}$ is $< 24 \text{ pF}$ )
Minimum Load Resistance (if required)	5,000			$\Omega$	Only use resistive loading if required by the differential receiver. Proper dc biasing should be used to be compatible with levels in Figure 3

<sup>1</sup> Input signal characteristics are defined in Figure 2.

<sup>2</sup> Output signal characteristics are defined in Figure 3.

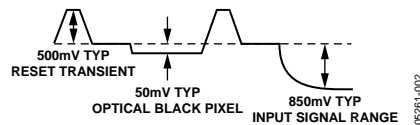

Figure 2. Input Signal Characteristics

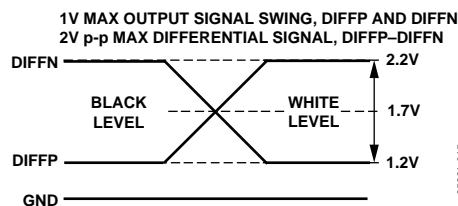

Figure 3. Output Signal Characteristics

**DIGITAL SPECIFICATIONS**

$T_{MIN}$  to  $T_{MAX}$ ,  $AVDD = DVDD = OVDD = TCVD = HVDD = RGVDD = 2.7 V$ ,  $-25^{\circ}C$  to  $+85^{\circ}C$ , unless otherwise noted.

Table 3.

Parameter	Symbol	Min	Typ	Max	Unit
LOGIC INPUTS					
High Level Input Voltage	$V_{IH}$	2.1			V
Low Level Input Voltage	$V_{IL}$			0.6	V
High Level Input Current	$I_{IH}$		10		$\mu A$
Low Level Input Current	$I_{IL}$		10		$\mu A$
Input Capacitance	$C_{IN}$		10		pF
LOGIC OUTPUTS					
High Level Output Voltage, $I_{OH} = 2 mA$	$V_{OH}$	2.2			V
Low Level Output Voltage, $I_{OL} = 2 mA$	$V_{OL}$			0.5	V
CLI INPUT					
High Level Input Voltage	$V_{IH-CLI}$	1.85			V
Low Level Input Voltage	$V_{IL-CLI}$			0.85	V
RG-DRIVER AND H-DRIVER OUTPUTS (powered by HVDD, RGVDD)					
High Level Output Voltage (at max output current)	$V_{OH}$	$VDD - 0.5$			V
Low Level Output Voltage (at max output current)	$V_{OL}$			0.5	V
Maximum Output Current (programmable)					
H-Driver (per output)		64			mA
RG-Driver, HL-Driver		15			mA
Maximum Load Capacitance					
H-Driver (per output)		100			pF
RG-Driver, HL-Driver		50			pF

**TIMING SPECIFICATIONS (SLAVE TIMING MODE)**

See Figure 10 for Timing Diagram.

Table 4.

Parameter	Symbol	Min	Typ	Max	Unit
MASTER CLOCK (CLI)					
CLI Clock Period	$T_{CLI}$	18			ns
CLI High Pulse Width	$T_{ADC}$		9		ns
Internal Delay from CLI to First Tap	$T_{CLIDLy}$		6		ns
SAMPLE CLOCKS					
SHP Rising to SHD Rising	$T_{S1}$	7.4	9		ns
ADCLK Edge Placement for AD9941	$T_{REC}$		3		ns
SERIAL INTERFACE					
Maximum SCK Frequency	$f_{SCLK}$	10			MHz
SL to SCK Setup Time	$t_{LS}$	10			ns
SCK to SL Hold Time	$t_{LH}$	10			ns
SDATA Valid to SCK Rising Edge Setup	$t_{DS}$	10			ns
SCK Rising Edge to SDATA Valid Hold	$t_{DH}$	10			ns

## ABSOLUTE MAXIMUM RATINGS

Table 5.

Parameter	Rating
AVDD and TCVDD to AVSS	−0.3 V to +3.9 V
HVDD and RGVDD to HVSS and RGVSS	−0.3 V to +3.9 V
DVDD and OVDD to DVSS and OVSS	−0.3 V to +3.9 V
Any VSS to Any VSS	−0.3 V to +0.3 V
CLPOB/HBLK to DVSS	−0.3 V to DVDD + 0.3 V
SCK, SL, and SDI to DVSS	−0.3 V to DVDD + 0.3 V
RG to RGVSS	−0.3 V to RGVDD + 0.3 V
H1–H4 to HVSS	−0.3 V to HVDD + 0.3 V
REFT, REFB, and CCDIN to AVSS	−0.3 V to AVDD + 0.3 V
Junction Temperature	150°C
Lead Temperature (10 sec)	350°C

Stresses at or above those listed under Absolute Maximum Ratings may cause permanent damage to the product. This is a stress rating only; functional operation of the product at these or any other conditions above those indicated in the operational section of this specification is not implied. Operation beyond the maximum operating conditions for extended periods may affect product reliability.

### THERMAL CHARACTERISTICS

$\theta_{JA}$  is measured using a 4-layer PCB with the exposed paddle soldered to the board.

Thermal resistance for 48-lead LQFP package:

$$\theta_{JA} = 92^{\circ}\text{C}/\text{W}$$

Thermal resistance for 48-lead LFCSP package:

$$\theta_{JA} = 24^{\circ}\text{C}/\text{W}^1$$

<sup>1</sup>  $\theta_{JA}$  is measured using a 4-layer PCB with the exposed paddle soldered to the board.

### ESD CAUTION

ESD (electrostatic discharge) sensitive device. Electrostatic charges as high as 4000 V readily accumulate on the human body and test equipment and can discharge without detection. Although this product features proprietary ESD protection circuitry, permanent damage may occur on devices subjected to high energy electrostatic discharges. Therefore, proper ESD precautions are recommended to avoid performance degradation or loss of functionality.



## PIN CONFIGURATION AND FUNCTION DESCRIPTIONS

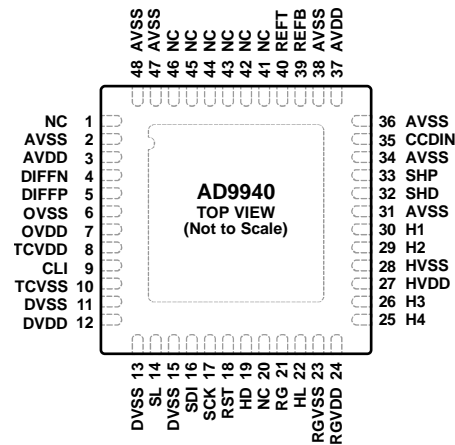

1. NC = NO CONNECT.
2. THE LFCSP PACKAGE HAS AN EXPOSED PAD. CONNECT THE EPAD TO GND.

05281-003

Figure 4. Pin Configuration

Table 6. Pin Function Descriptions

Pin No.	Mnemonic	Type <sup>1</sup>	Description
1	NC	NC	No Connect. Connect to GND.
2	AVSS	P	Analog Ground.
3	AVDD	P	Analog Supply.
4	DIFFN	AO	CDS Output, Data (Negative).
5	DIFFP	AO	CDS Output, Data (Positive).
6	OVSS	P	Analog Output Buffer Ground.
7	OVDD	P	Analog Output Buffer Supply.
8	TCVDD	P	Analog Supply for Timing Core.
9	CLI	DI	Reference Clock Input.
10	TCVSS	P	Analog Ground for Timing Core.
11	DVSS	P	Digital Ground.
12	DVDD	P	Digital Logic Power Supply.
13	DVSS	P	Digital Ground.
14	SL	DI	3-Wire Serial Load Pulse.
15	DVSS	P	Digital Ground.
16	SDI	DI	3-Wire Serial Data Input.
17	SCK	DI	3-Wire Serial Clock.
18	RST	DI	Hardware Reset (Low Active). Low = Reset state, High = Normal operation.
19	HD	DI	Horizontal Sync Pulse.
20	NC	NC	Do No Connect. Should be left floating.
21	RG	DO	CCD Reset Gate Clock.
22	HL	DO	HL Horizontal Clock.
23	RGVSS	P	RG Driver Ground.
24	RGVDD	P	RG Driver Power Supply.
25	H4	DO	CCD Horizontal Clock 4.
26	H3	DO	CCD Horizontal Clock 3.
27	HVDD	P	Horizontal Clock Driver Supply.
28	HVSS	P	Horizontal Clock Driver Ground.
29	H2	DO	CCD Horizontal Clock 2.
30	H1	DO	CCD Horizontal Clock 1.
31	AVSS	P	Analog Ground.
32	SHD	DI	Test Clock Input for CCD Data Phase Sampling.

Pin No.	Mnemonic	Type <sup>1</sup>	Description
33	SHP	DI	Test Clock Input for CCD Reset Phase Sampling.
34	AVSS	P	Analog Ground.
35	CCDIN	AI	CCD Signal Input.
36	AVSS	P	Analog Ground (CCD Signal Input Reference).
37	AVDD	P	Analog Supply.
38	AVSS	P	Analog Ground.
39	REFB	AO	Voltage Reference Bottom By-Pass. Decoupled to analog ground with a 0.1 $\mu$ F capacitor.
40	REFT	AO	Voltage Reference Top By-Pass. Decoupled to analog ground with a 0.1 $\mu$ F capacitor.
41 to 46	NC	NC	No Connect. Connect to GND.
47, 48	AVSS	P	Analog Ground.
	EPAD		Exposed Pad. The LFCSP has an exposed pad. Connect the EPAD to GND.

<sup>1</sup> Type: AI = analog input; AO = analog output; DI = digital input; DO = digital output; P = power.



## DATA BIT DESCRIPTIONS

Table 7.

Address	Data Bit Content	Default Value	Name	Description
0	[0]	0	PARTSEL	Part Select: 0 = select AD9940 1 = select AD9941
	[1]	0	TESTMODE	Always set = 0
	[2]	0	SW RESET	Reset registers: 1 = reset all registers to the default values
	[3]	0	MODE	0 = slave mode 1 = master mode
	[4]	0	STANDBY	0 = normal operation 1 = standby operation
	[6:5]	0	TESTMODE	Always Set = 0
	[7]	0	WRITEMODE	0 = write to Address 1 to Address 13 1 = write to Address 14 to Address 26
1	[6:0]	0	TESTMODE	Always set = 0
	[7]	0	HBLKMASKPOL	HBLK mask polarity: 0 = H1/H3 low, H2/H4 high 1 = H1/H3 high, H2/H4 low
2	[0]	0	HBLKTOG1_0 [8]	HBLKTOG1 position for Sequence 0 (Bit 8)
	[1]	0	HBLKTOG1_0 [9]	HBLKTOG1 position for Sequence 0 (Bit 9)
	[2]	0	HBLKTOG1_0 [10]	HBLKTOG1 position for Sequence 0 (Bit 10)
	[3]	0	HBLKTOG1_0 [11]	HBLKTOG1 position for Sequence 0 (Bit 11)
	[7:4]	0	TESTMODE	Always set = 0
3	[0]	0	HBLKTOG1_0 [0]	HBLKTOG1 position for Sequence 0 (Bit 0)
	[1]	0	HBLKTOG1_0 [1]	HBLKTOG1 position for Sequence 0 (Bit 1)
	[2]	0	HBLKTOG1_0 [2]	HBLKTOG1 position for Sequence 0 (Bit 2)
	[3]	0	HBLKTOG1_0 [3]	HBLKTOG1 position for Sequence 0 (Bit 3)
	[4]	0	HBLKTOG1_0 [4]	HBLKTOG1 position for Sequence 0 (Bit 4)
	[5]	0	HBLKTOG1_0 [5]	HBLKTOG1 position for Sequence 0 (Bit 5)
	[6]	1	HBLKTOG1_0 [6]	HBLKTOG1 position for Sequence 0 (Bit 6)
	[7]	0	HBLKTOG1_0 [7]	HBLKTOG1 position for Sequence 0 (Bit 7)
4	[0]	0	HBLKTOG2_0 [8]	HBLKTOG2 position for Sequence 0 (Bit 8)
	[1]	0	HBLKTOG2_0 [9]	HBLKTOG2 position for Sequence 0 (Bit 9)
	[2]	0	HBLKTOG2_0 [10]	HBLKTOG2 position for Sequence 0 (Bit 10)
	[3]	0	HBLKTOG2_0 [11]	HBLKTOG2 position for Sequence 0 (Bit 11)
	[7:4]	0	TESTMODE	Always set = 0
5	[0]	0	HBLKTOG2_0 [0]	HBLKTOG2 position for Sequence 0 (Bit 0)
	[1]	0	HBLKTOG2_0 [1]	HBLKTOG2 position for Sequence 0 (Bit 1)
	[2]	0	HBLKTOG2_0 [2]	HBLKTOG2 position for Sequence 0 (Bit 2)
	[3]	0	HBLKTOG2_0 [3]	HBLKTOG2 position for Sequence 0 (Bit 3)
	[4]	0	HBLKTOG2_0 [4]	HBLKTOG2 position for Sequence 0 (Bit 4)
	[5]	0	HBLKTOG2_0 [5]	HBLKTOG2 position for Sequence 0 (Bit 5)
	[6]	1	HBLKTOG2_0 [6]	HBLKTOG2 position for Sequence 0 (Bit 6)
	[7]	0	HBLKTOG2_0 [7]	HBLKTOG2 position for Sequence 0 (Bit 7)
6	[0]	0	HBLKTOG1_1 [8]	HBLKTOG1 position for Sequence 1 (Bit 8)
	[1]	0	HBLKTOG1_1 [9]	HBLKTOG1 position for Sequence 1 (Bit 9)
	[2]	0	HBLKTOG1_1 [10]	HBLKTOG1 position for Sequence 1 (Bit 10)
	[3]	0	HBLKTOG1_1 [11]	HBLKTOG1 position for Sequence 1 (Bit 11)
	[7:4]	0	TESTMODE	Always set = 0

Address	Data Bit Content	Default Value	Name	Description
7	[0]	0	HBLKTOG1_1 [0]	HBLKTOG1 position for Sequence 1 (Bit 0)
	[1]	0	HBLKTOG1_1 [1]	HBLKTOG1 position for Sequence 1 (Bit 1)
	[2]	0	HBLKTOG1_1 [2]	HBLKTOG1 position for Sequence 1 (Bit 2)
	[3]	0	HBLKTOG1_1 [3]	HBLKTOG1 position for Sequence 1 (Bit 3)
	[4]	0	HBLKTOG1_1 [4]	HBLKTOG1 position for Sequence 1 (Bit 4)
	[5]	0	HBLKTOG1_1 [5]	HBLKTOG1 position for Sequence 1 (Bit 5)
	[6]	1	HBLKTOG1_1 [6]	HBLKTOG1 position for Sequence 1 (Bit 6)
	[7]	0	HBLKTOG1_1 [7]	HBLKTOG1 position for Sequence 1 (Bit 7)
8	[0]	0	HBLKTOG2_1 [8]	HBLKTOG2 position for Sequence 1 (Bit 8)
	[1]	0	HBLKTOG2_1 [9]	HBLKTOG2 position for Sequence 1 (Bit 9)
	[2]	0	HBLKTOG2_1 [10]	HBLKTOG2 position for Sequence 1 (Bit 10)
	[3]	0	HBLKTOG2_1 [11]	HBLKTOG2 position for Sequence 1 (Bit 11)
	[7:4]	0	TESTMODE	Always set = 0
9	[0]	0	HBLKTOG2_1 [0]	HBLKTOG2 position for Sequence 1 (Bit 0)
	[1]	0	HBLKTOG2_1 [1]	HBLKTOG2 position for Sequence 1 (Bit 1)
	[2]	0	HBLKTOG2_1 [2]	HBLKTOG2 position for Sequence 1 (Bit 2)
	[3]	0	HBLKTOG2_1 [3]	HBLKTOG2 position for Sequence 1 (Bit 3)
	[4]	0	HBLKTOG2_1 [4]	HBLKTOG2 position for Sequence 1 (Bit 4)
	[5]	0	HBLKTOG2_1 [5]	HBLKTOG2 position for Sequence 1 (Bit 5)
	[6]	1	HBLKTOG2_1 [6]	HBLKTOG2 position for Sequence 1 (Bit 6)
	[7]	0	HBLKTOG2_1 [7]	HBLKTOG2 position for Sequence 1 (Bit 7)
10	[0]	0	HBLKTOG1_2 [8]	HBLKTOG1 position for Sequence 2 (Bit 8)
	[1]	0	HBLKTOG1_2 [9]	HBLKTOG1 position for Sequence 2 (Bit 9)
	[2]	0	HBLKTOG1_2 [10]	HBLKTOG1 position for Sequence 2 (Bit 10)
	[3]	0	HBLKTOG1_2 [11]	HBLKTOG1 position for Sequence 2 (Bit 11)
	[7:4]	0	TESTMODE	Always set = 0
11	[0]	0	HBLKTOG1_2 [0]	HBLKTOG1 position for Sequence 2 (Bit 0)
	[1]	0	HBLKTOG1_2 [1]	HBLKTOG1 position for Sequence 2 (Bit 1)
	[2]	0	HBLKTOG1_2 [2]	HBLKTOG1 position for Sequence 2 (Bit 2)
	[3]	0	HBLKTOG1_2 [3]	HBLKTOG1 position for Sequence 2 (Bit 3)
	[4]	0	HBLKTOG1_2 [4]	HBLKTOG1 position for Sequence 2 (Bit 4)
	[5]	0	HBLKTOG1_2 [5]	HBLKTOG1 position for Sequence 2 (Bit 5)
	[6]	1	HBLKTOG1_2 [6]	HBLKTOG1 position for Sequence 2 (Bit 6)
	[7]	0	HBLKTOG1_2 [7]	HBLKTOG1 position for Sequence 2 (Bit 7)
12	[0]	0	HBLKTOG2_2 [8]	HBLKTOG2 position for Sequence 2 (Bit 8)
	[1]	0	HBLKTOG2_2 [9]	HBLKTOG2 position for Sequence 2 (Bit 9)
	[2]	0	HBLKTOG2_2 [10]	HBLKTOG2 position for Sequence 2 (Bit 10)
	[3]	0	HBLKTOG2_2 [11]	HBLKTOG2 position for Sequence 2 (Bit 11)
	[7:4]	0	TESTMODE	Always set = 0
13	[0]	0	HBLKTOG2_2 [0]	HBLKTOG2 position for Sequence 2 (Bit 0)
	[1]	0	HBLKTOG2_2 [1]	HBLKTOG2 position for Sequence 2 (Bit 1)
	[2]	0	HBLKTOG2_2 [2]	HBLKTOG2 position for Sequence 2 (Bit 2)
	[3]	0	HBLKTOG2_2 [3]	HBLKTOG2 position for Sequence 2 (Bit 3)
	[4]	0	HBLKTOG2_2 [4]	HBLKTOG2 position for Sequence 2 (Bit 4)
	[5]	0	HBLKTOG2_2 [5]	HBLKTOG2 position for Sequence 2 (Bit 5)
	[6]	1	HBLKTOG2_2 [6]	HBLKTOG2 position for Sequence 2 (Bit 6)
	[7]	0	HBLKTOG2_2 [7]	HBLKTOG2 position for Sequence 2 (Bit 7)

Address	Data Bit Content	Default Value	Name	Description
14	[2:0]	3	RGDRV	RG drive strength (resolution = 2.2 mA/Step): 0 = Off 1 = 2.2 mA 2 = 4.4 mA ... 7 = 15.4 mA
	[3]	0	RGPOL	RG polarity: 0 = normal 1 = inverted
	[6:4]	3	HLDRV	HL drive strength (Resolution = 2.2 mA/Step): 0 = off 1 = 2.2 mA 2 = 4.4 mA ... 7 = 15.4 mA
	[7]	0	HLPOL	HL polarity: 0 = normal 1 = inverted
15	[5:0]	0	HLPOSLOC	HL rising edge location
	[7:6]	—	Unused	
16	[5:0]	24	HLNEGLOC	HL negative edge location
	[7:6]	0	Unused	
17	[5:0]	0	RGPOSLOC	RG rising edge location
	[7:6]	—	Unused	
18	[5:0]	24	RGNEGLOC	RG negative edge location
	[7:6]	—	Unused	
19	[3:0]	7	H2/H4DRV	H2/H4 drive strength (resolution = 4.3 mA/Step): 0 = Off 1 = 4.3 mA 2 = 8.6 mA ... 15 = 64.5 mA
	[7:4]	7	H1/H3DRV	H1/H3 drive strength (resolution = 4.3 mA/Step): 0 = Off 1 = 4.3 mA 2 = 8.6 mA ... 15 = 64.5 mA
20	[5:0]	0	H1POSLOC	H1 positive edge location
	[6]	—	Unused	
	[7]	0	H1/H3POL	H1/H3 polarity: 0 = normal 1 = inverted (H2/H4 is opposite polarity of H1/H3)
21	[5:0]	32	H1NEGLOC	H1 negative edge location
	[7:6]	—	Unused	
22	[5:0]	32	SHPLOC	SHP sampling location
	[7:6]	0	Unused	
23	[5:0]	0	SHDLOC	SHD sampling location
	[7:6]	—	Unused	
24	[7:0]	0	TESTMODE	Always set = 0
25	[7:0]	0	TESTMODE	Always set = 0
26	[7:0]	0	TESTMODE	Always set = 0

## SERIAL INTERFACE TIMING

All the internal registers of the AD9940 are accessed through a 3-wire serial interface. Each register consists of an 8-bit data byte starting with the LSB bit. As shown in Figure 5, the data bits are clocked in on the rising edge of SCK after SL is asserted low and the entire 8-bit word is latched in on the rising edge of SL after the last MSB bit. Consecutive serial writes are performed starting with Address 0 and ending with an address MSB bit prior to asserting SL high.

The AD9940 contains two banks of registers, which are programmed independently. Bank 1 consists of the registers located at Address 0 to Address 13, and Bank 2 consists of Address 14 to Address 26. The WRITEMODE register located at Address 0 is used to select which register bank is written to.

Every write operation must begin with a write to Address 0 to specify Part select bit and Bank location, then followed with any number of consecutive data words. Address 0 is always followed by Address 01 or Address 14 depending on the value specified for WRITEMODE (used for Bank selection).

A hard reset is recommended after power-up to reset the AD9940 prior to performing a serial interface write. A hard reset is performed by asserting the RST pin low for a minimum of 10  $\mu$ s. The serial interface pins SCK, SL, and SDI must be in a know state after the RST has been applied.

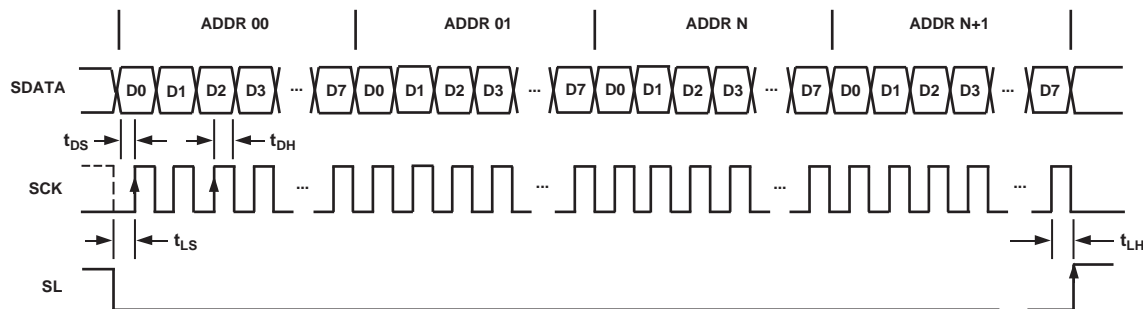

### NOTES

1. ANY NUMBER OF ADJACENT REGISTERS CAN BE LOADED SEQUENTIALLY, BEGINNING WITH THE LOWEST ADDRESS 00.
2. WHEN SEQUENTIALLY LOADING MULTIPLE REGISTERS, THE EXACT REGISTER LENGTH (SHOWN ABOVE) MUST BE USED FOR EACH REGISTER.
3. ALL LOADED REGISTERS ARE SIMULTANEOUSLY UPDATED ON THE RISING EDGE OF SL.

Figure 5. Serial Interface Operation

05261-004

## SYSTEM OVERVIEW

Figure 6 shows the typical system block diagram for the AD9940. The CCD output is processed by the AD9940's AFE circuitry, which consists of a correlated double sampler (CDS) and output buffer. The differential output of the AD9940 provides good signal integrity when interfaced with the AD9941.

To operate the AD9940, all CCD and AFE timing parameters are programmed into the AD9940 from the system micro-processor through the 3-wire serial interface. From the system master clock, CLI, provided by the image processor or external crystal, the AD9940 generates the CCD's horizontal and reset gate clocks and all internal AFE clocks.

The H-drivers for H1 to H4, HL and RG, are included in the AD9940, allowing these clocks to be directly connected to the CCD. An H-drive voltage of up to 3.6 V is supported.

## ANALOG FRONT END OPERATION

The AD9940 signal-processing chain is shown in Figure 7, consisting of a dc restore circuit, CDS, and output buffer.

### DC Restore

To reduce the large dc offset of the CCD output signal, a dc restore circuit is used with an external 0.1 μF series coupling capacitor. This restores the dc level of the CCD signal to approximately 1.5 V to be compatible with the 3 V analog supply of the AD9940.

### Correlated Double Sampler

The CDS circuit samples each CCD pixel twice to extract the video information and reject low frequency noise. The timing diagram in Figure 10 illustrates how the two internally generated CDS clocks, SHP and SHD, are used to sample the reference level and the data level, respectively, of the CCD signal. The placement of the SHP and SHD sampling edges is determined by the setting of the SHPLOC (Address 22) and SHDLOC (Address 23) control registers. Placement of these two clock edges is critical to achieve the best performance from the CCD.

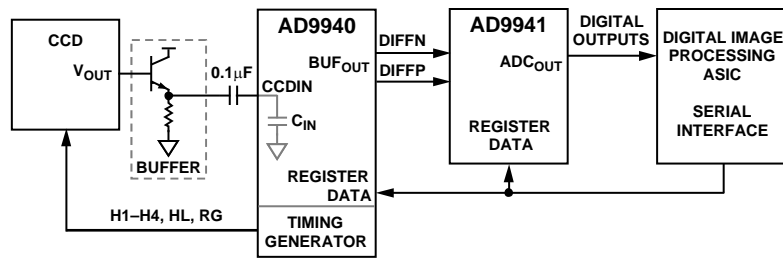

Figure 6. Typical System Block Diagram

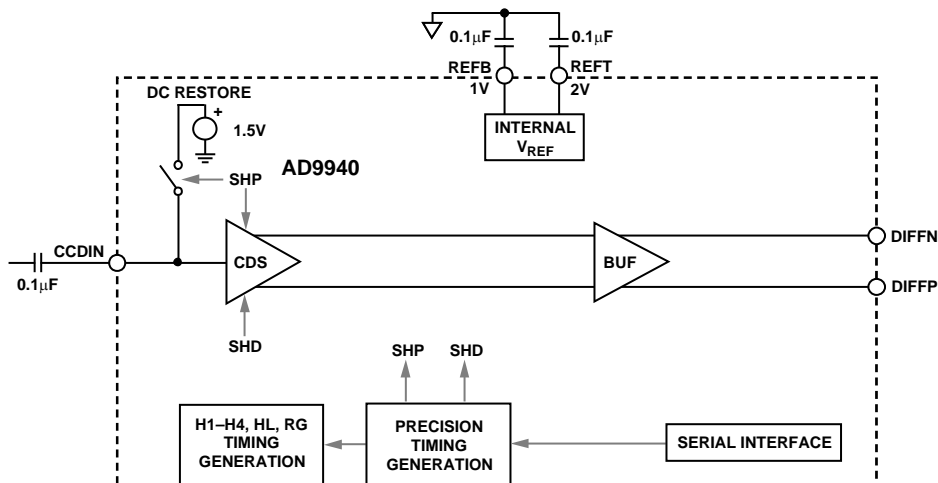

Figure 7. AD9940 Signal-Processing Chain

## PRECISION TIMING, HIGH SPEED TIMING GENERATION

The AD9940 generates flexible, high speed timing signals using the Precision Timing core. This core is the foundation for generating the timing used for both the CCD and the AFE: the reset gate RG, horizontal drivers H1 to H4, and the SHP/SHD sample clocks. A unique architecture makes it routine for the system designer to optimize image quality by providing precise control over the horizontal CCD readout and the AFE correlated double sampling.

### TIMING RESOLUTION

The Precision Timing core uses a  $1\times$  master clock input (CLI) as a reference. This clock should be the same as the CCD pixel clock frequency. Figure 8 illustrates how the internal timing core divides the master clock period into 48 steps or edge positions. Therefore, the edge resolution of the Precision Timing core is  $(t_{CLI}/48)$ .

### HIGH SPEED CLOCK PROGRAMMABILITY

Figure 9 shows how the high speed clocks, RG, HL, H1–H4, SHP, and SHD are generated. The RG pulse has programmable rising and falling edges, and can be inverted using the polarity control. The horizontal clocks H1/H3 have programmable rising and falling edges, and polarity control. The H2/H4 clocks are always inverses of the H1/H3 H-driver outputs.

Table 8 summarizes the high speed timing registers and their parameters. Each edge location setting is 6 bits wide, but only 48 valid edge locations are available. Therefore, the register values are mapped into four quadrants, with each quadrant containing 12 edge locations. Table 9 shows the correct register values for the corresponding edge locations.

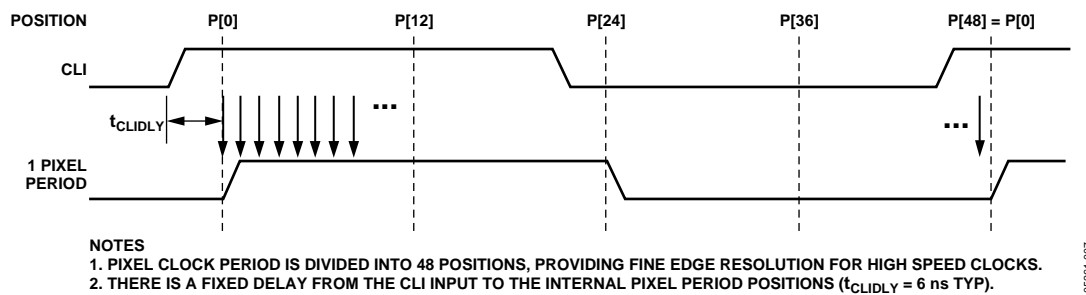

Figure 8. High Speed Clock Resolution from CLI Master Clock Input

05261-007

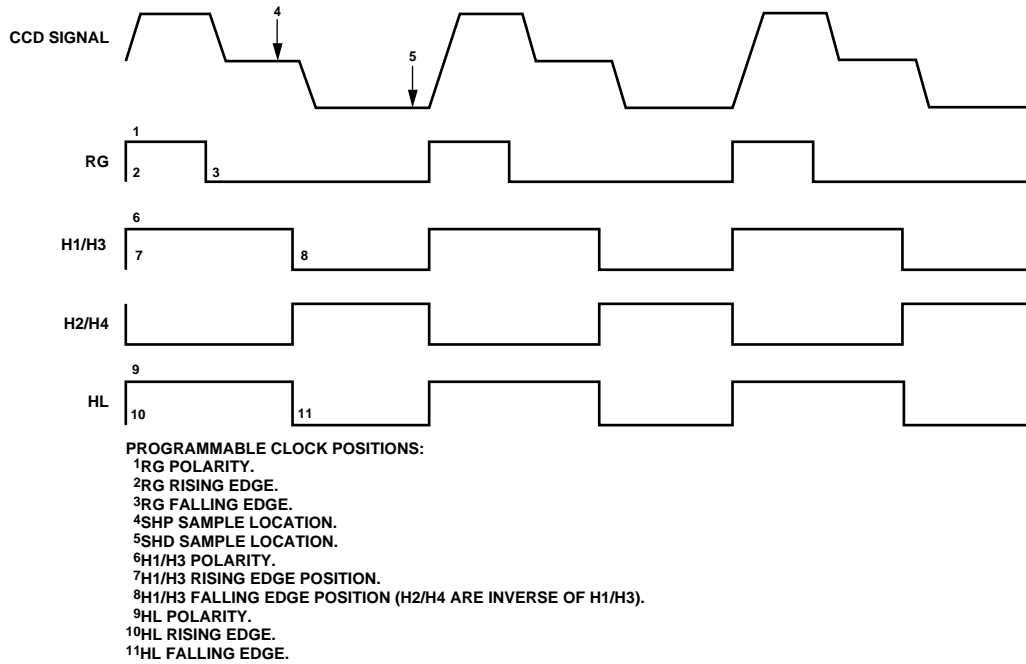

Figure 9. High Speed Clock Programmable Locations

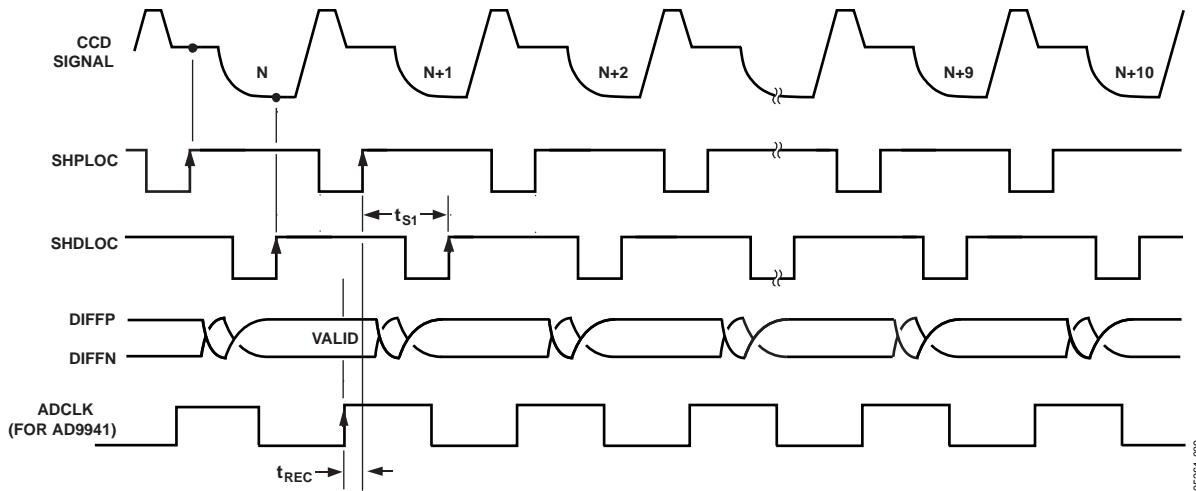

Figure 10. SHP, SHD, and Data Output Timing

**H-DRIVER AND RG OUTPUTS**

In addition to the programmable timing positions, the AD9940 features on-chip output drivers for the RG and H1 to H4 outputs. These drivers are powerful enough to directly drive the CCD inputs. The H-driver and RG driver current can be adjusted for optimum rise/fall time into a particular load using the H1/H3DRV, H2/H4DRV, RGDRV, and HLDRV registers. The horizontal output drive strength register is divided into fifteen different 4-bit values, each one adjustable in 4.3 mA increments. The minimum setting of 0 is off or three-state, and the maximum setting of 15 is 64.5 mA.

The RG and HL output drive strength registers are divided into seven 3-bit values, each adjustable in 2.2 mA increments. The minimum setting of 0 is equal to off or three-state, and the maximum setting of 7 is 15.4 mA.

As shown in Figure 11, the H2/H4 outputs are inverses of H1/H3. The internal propagation delay resulting from the signal inversion is less than 1 ns, which is significantly less than the typical rise time driving the CCD load. This results in an H1/H2 crossover voltage at approximately 50% of the output swing. The crossover voltage is not programmable.

**Table 8. Timing Core Register Parameters for H1, H3, RG1, RG2, and SHP/SHD**

Parameter	Length (Bits)	Range	Description
Polarity	1	High/low	Polarity control for H1/H3, RG1, and RG2: 0 = no inversion. 1 = inversion.
Positive Edge	6	0 to 47 edge location	Positive edge location for H1/H3, RG1, and RG2.
Negative Edge	6	0 to 47 edge location	Negative edge location for H1/H3, RG1, and RG2.
Sample Location	6	0 to 47 sample location	Sampling location for SHP and SHD.
H-Drive Control	4	0 to 15 current steps	Drive current for H1 to H4, 0 to 15 steps of 4.3 mA each.
RG-Drive Control	3	0 to 7 current steps	Drive current for RG, 0 to 7 steps of 2.2 mA each.
HL-Drive Control	3	0 to 7 current steps	Drive current for HL, 0 to 7 steps of 2.2 mA each.

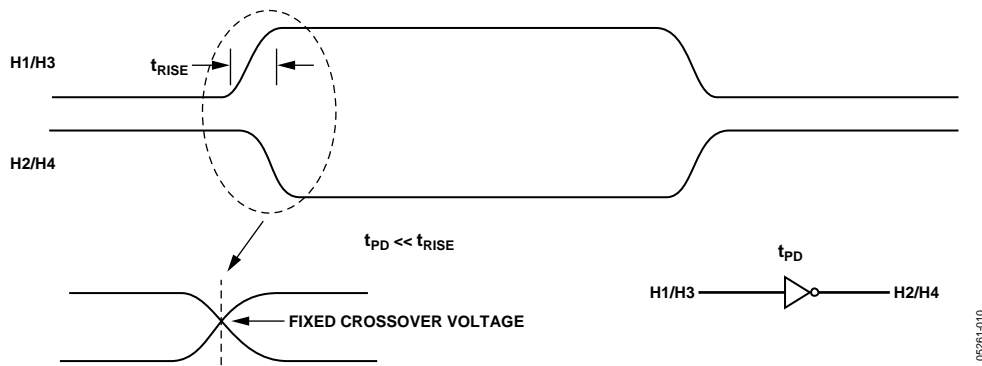

Figure 11. H-Clock Inverse Phase Relationship

**Table 9. Precision Timing Edge Locations**

Quadrant	Edge Location (Decimal)	Register Value (Decimal)	Register Value (Binary)
I	0 to 11	0 to 11	00 0000 to 00 1011
II	12 to 23	16 to 27	01 0000 to 01 1011
III	24 to 35	32 to 43	10 0000 to 10 1011
IV	36 to 47	48 to 59	11 0000 to 11 1011



### HBLK SEQUENCES

The HBLK programmable timing shown in Figure 12 is programmed using the HBLKTOG registers. Only the toggle positions are used to designate the start and the stop positions of the blanking period. Additionally, a polarity control, HBLKMASKPOL, designates the polarity of the horizontal clock signals H1 to H4 during the blanking period. Setting HBLKMASKPOL high sets H1 = H3 = high and H2 = H4 = low during the blanking.

### Individual HBLK Sequences

Up to three individual HBLK sequences are available in each line. This allows special H-blanking as shown in Figure 14. The HBLK sequences are sequential starting with Sequence 0. To ensure proper HBLK operation, the following sequence is required for values programmed in the HBLKTOG registers:

$$\begin{aligned} & \text{HBLKTOG1}_0 < \text{HBLKTOG2}_0 < \text{HBLKTOG1}_1 < \\ & \text{HBLKTOG2}_1 < \text{HBLKTOG1}_2 < \text{HBLKTOG2}_2 \end{aligned}$$

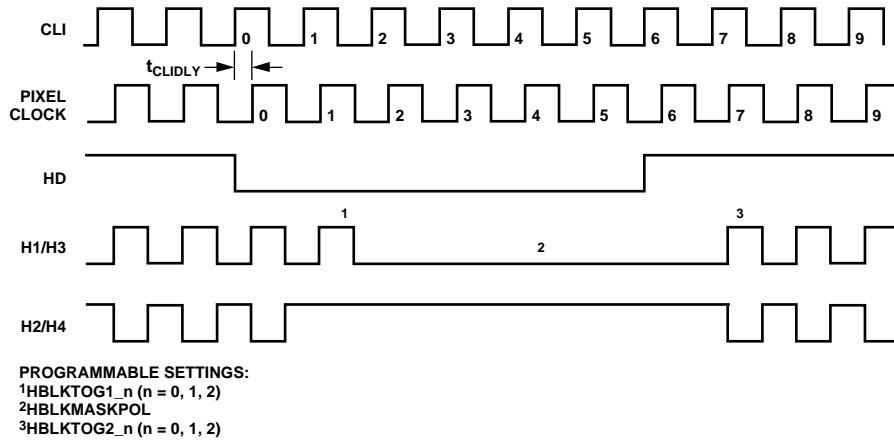

Figure 12. Horizontal Blanking Example Showing HBLKTOG1\_0 = 0, HBLKMASKPOL = 0, and HBLKTOG2\_0 = 3

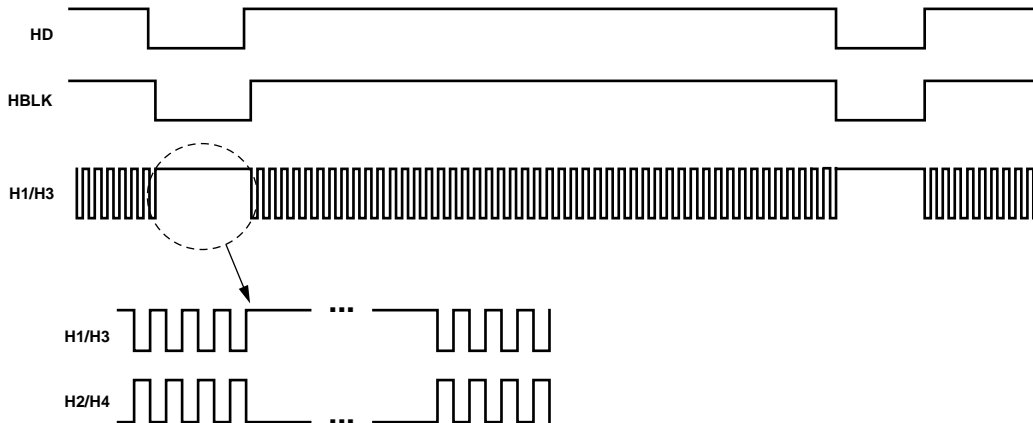
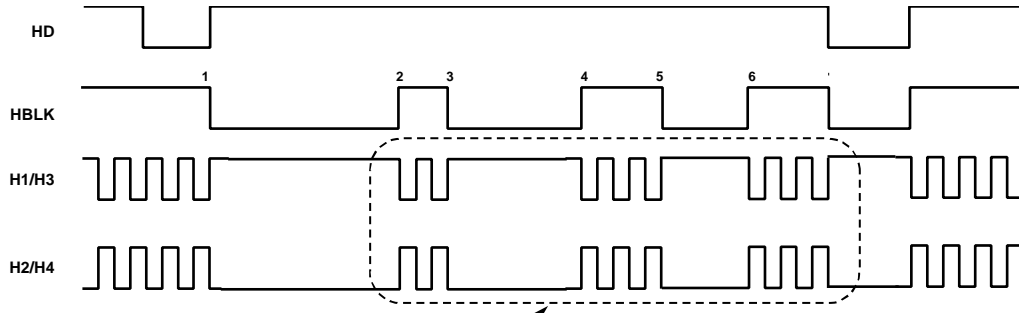

Figure 13. HBLK Masking Control



SPECIAL H-BLANK PATTERN IS CREATED USING MULTIPLE HBLK TOGGLE POSITIONS.

PROGRAMMABLE SETTINGS:

- 1HBLKTOG1\_0
- 2HBLKTOG2\_0
- 3HBLKTOG1\_1
- 4HBLKTOG2\_1
- 5HBLKTOG1\_2
- 6HBLKTOG2\_2

05261-013

Figure 14. Generating Special HBLK Patterns

### APPLICATIONS INFORMATION

All signals should be carefully routed on the PCB to maintain low noise performance. The CCD output signal should be connected to the CCDIN pin through a 0.1  $\mu$ F capacitor. The CCD timing signals H1A/B to H2A/B and RG1 to RG2 should be routed directly to the CCD with minimum trace lengths. The clock inputs are located on the other side of the package, where the analog pins are located, and should be connected to the digital ASIC away from the analog and CCD clock signals.

A single ground plane is recommended for the AD9940. This ground plane should be as continuous as possible, particularly where analog pins are concentrated, to ensure that all analog decoupling capacitors provide the lowest possible impedance path between the power and bypass pins and their respective ground pins.

All decoupling capacitors should be located as close as possible to the package pins. Careful use of a split ground plane can be effective to avoid the return current of horizontal driver flows into analog ground, thereby reducing coupling noise.

Power-supply decoupling is very important for achieving low noise performance. Figure 15 shows the local high frequency decoupling capacitors, but additional capacitance is recommended for lower frequencies. Additional capacitors and ferrite beads can further reduce noise.

When using the LFCSP package, it is recommended that the exposed paddle on the bottom of the package be soldered to a large pad, with multiple vias connecting the pad to the ground plane.

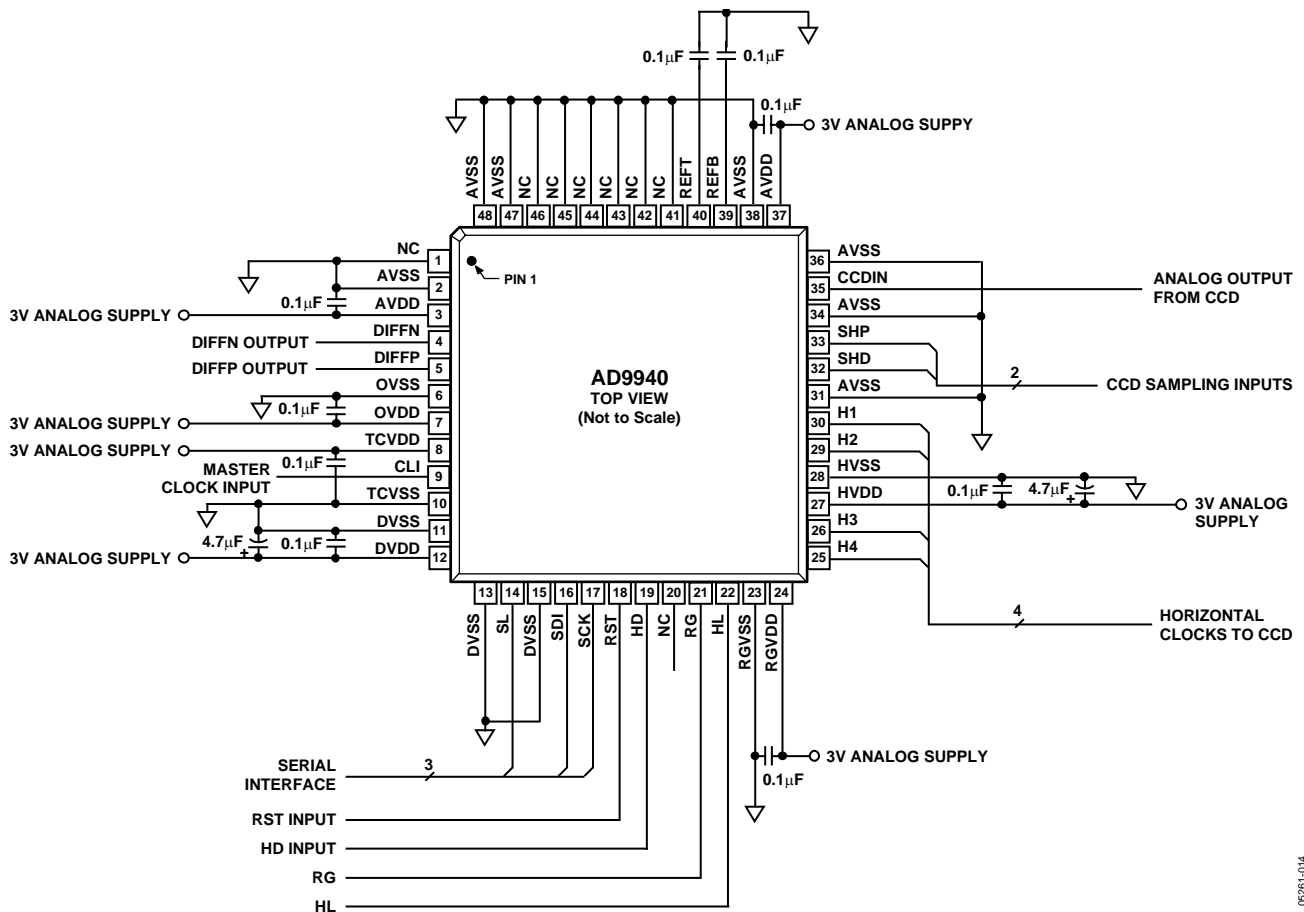
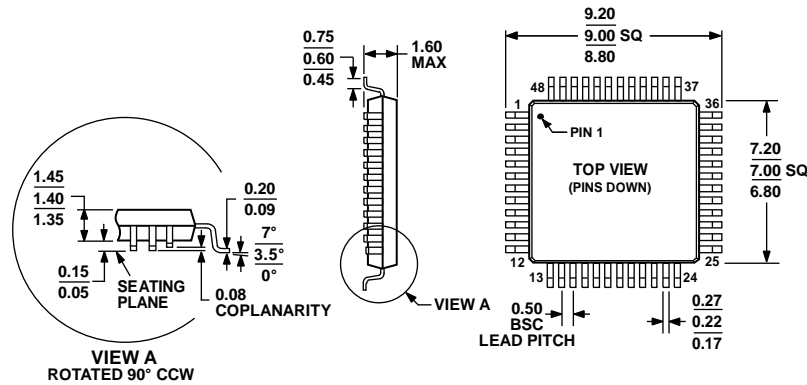

Figure 15. Recommended Circuit Configuration

65281-0/4

OUTLINE DIMENSIONS



COMPLIANT TO JEDEC STANDARDS MS-026-BBC

Figure 16. 48-Lead Low Profile Quad Flat Package [LQFP] (ST-48)

Dimensions shown in millimeters

051706-A

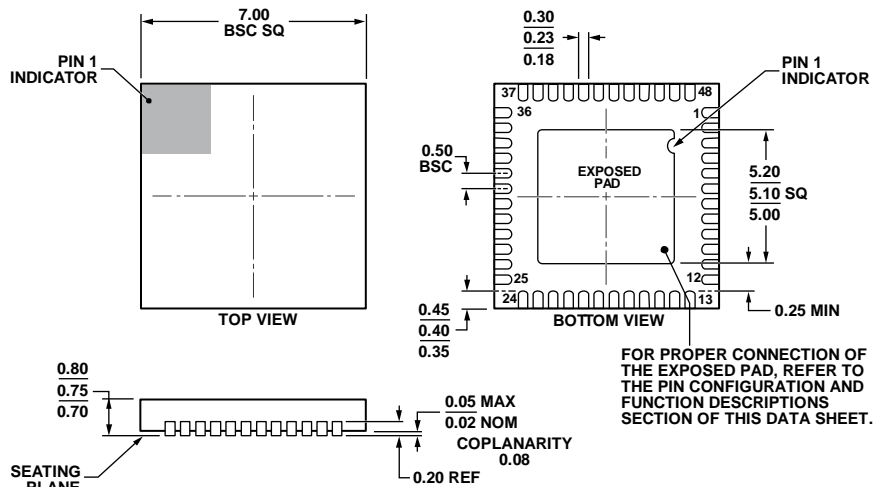

COMPLIANT TO JEDEC STANDARDS MO-220-WKKD.

Figure 17. 48-Lead Lead Frame Chip Scale Package [LFCSP] 7 mm x 7mm Body and 0.75 mm Package Height (CP-48-4)

Dimensions shown in millimeters

112408-B

ORDERING GUIDE

Model <sup>1</sup>	Temperature Range	Package Description	Package Option
AD9940BSTZ	-25°C to +85°C	48-Lead Low Profile Quad Flat Package [LQFP]	ST-48
AD9940BSTZRL	-25°C to +85°C	48-Lead Low Profile Quad Flat Package [LQFP]	ST-48
AD9940BCPZ	-25°C to +85°C	48-Lead Lead Frame Chip Scale Package [LFCSP]	CP-48-4
AD9940BCPZRL	-25°C to +85°C	48-Lead Lead Frame Chip Scale Package [LFCSP]	CP-48-4

<sup>1</sup> Z = RoHs Compliant Part.

Компания «Океан Электроники» предлагает заключение долгосрочных отношений при поставках импортных электронных компонентов на взаимовыгодных условиях!

Наши преимущества:

- Поставка оригинальных импортных электронных компонентов напрямую с производств Америки, Европы и Азии, а так же с крупнейших складов мира;
- Широкая линейка поставок активных и пассивных импортных электронных компонентов (более 30 млн. наименований);
- Поставка сложных, дефицитных, либо снятых с производства позиций;
- Оперативные сроки поставки под заказ (от 5 рабочих дней);
- Экспресс доставка в любую точку России;
- Помощь Конструкторского Отдела и консультации квалифицированных инженеров;
- Техническая поддержка проекта, помощь в подборе аналогов, поставка прототипов;
- Поставка электронных компонентов под контролем ВП;
- Система менеджмента качества сертифицирована по Международному стандарту ISO 9001;
- При необходимости вся продукция военного и аэрокосмического назначения проходит испытания и сертификацию в лаборатории (по согласованию с заказчиком);
- Поставка специализированных компонентов военного и аэрокосмического уровня качества (Xilinx, Altera, Analog Devices, Intersil, Interpoint, Microsemi, Actel, Aeroflex, Peregrine, VPT, Syfer, Eurofarad, Texas Instruments, MS Kennedy, Miteq, Cobham, E2V, MA-COM, Hittite, Mini-Circuits, General Dynamics и др.);

Компания «Океан Электроники» является официальным дистрибьютором и эксклюзивным представителем в России одного из крупнейших производителей разъемов военного и аэрокосмического назначения «JONHON», а так же официальным дистрибьютором и эксклюзивным представителем в России производителя высокотехнологичных и надежных решений для передачи СВЧ сигналов «FORSTAR».



## JONHON

«JONHON» (основан в 1970 г.)

Разъемы специального, военного и аэрокосмического назначения:

(Применяются в военной, авиационной, аэрокосмической, морской, железнодорожной, горно- и нефтедобывающей отраслях промышленности)

«FORSTAR» (основан в 1998 г.)

ВЧ соединители, коаксиальные кабели, кабельные сборки и микроволновые компоненты:

(Применяются в телекоммуникациях гражданского и специального назначения, в средствах связи, РЛС, а так же военной, авиационной и аэрокосмической отраслях промышленности).



Телефон: 8 (812) 309-75-97 (многоканальный)

Факс: 8 (812) 320-03-32

Электронная почта: [ocean@oceanchips.ru](mailto:ocean@oceanchips.ru)

Web: <http://oceanchips.ru/>

Адрес: 198099, г. Санкт-Петербург, ул. Калинина, д. 2, корп. 4, лит. А