

Advanced constant voltage and constant current controller

Features

- Constant voltage and constant current control
- Wide operating V_{CC} range [3.5 - 36] V
- Low quiescent consumption: 200 μ A
- Voltage reference: 2.5 V
- Voltage control loop accuracy \pm 0.5%
- Current sense threshold: 50 mV
- Open-drain output stage
- Low external component count
- SOT23-6L micro package

Applications

- Battery chargers
- AC-DC adapters
- LED drivers

Description

The SEA05 is a highly integrated solution for SMPS applications requiring a dual control loop to perform CV (constant voltage) and CC (constant current) regulation.

The device integrates a voltage reference, two op-amps (with OR-ed open-drain outputs), and a low-side current sensing circuit.

The voltage reference, along with one op-amp, is the core of the voltage control loop; the current sensing circuit and the other op-amp make up the current control loop.

The external components needed to complete the two control loops are: a resistor divider that senses the output of the power supply and fixes the voltage regulation setpoint at the specified value; a sense resistor that feeds the current sensing circuit with a voltage proportional to the dc output current; this resistor determines the current regulation setpoint and must be



adequately rated in terms of power dissipation; the frequency compensation components (R-C networks) for both loops.

The device, housed in one of the smallest available packages, is ideal for space-shrunk applications such as adapters and chargers.

Figure 1. Internal schematic

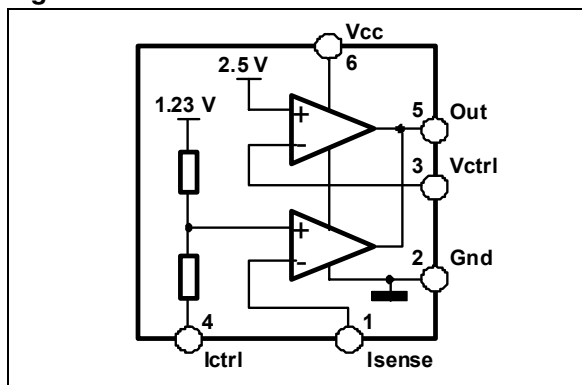
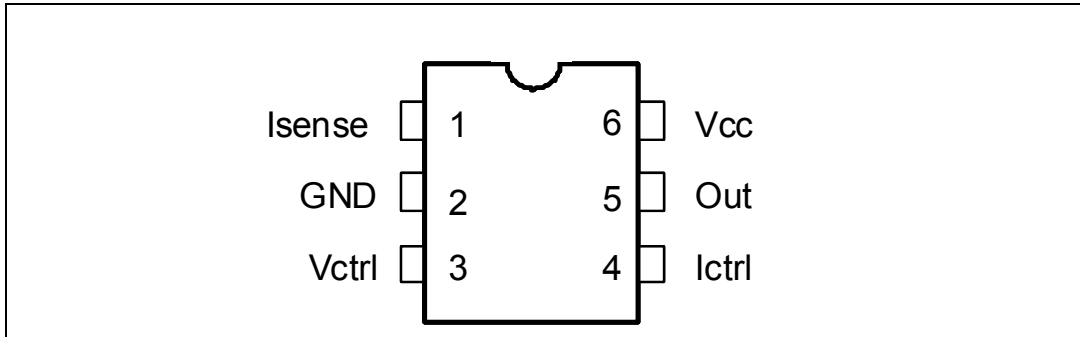

Table 1. Device summary

Order code	Package	Packing
SEA05TR	SOT23-6L	Tape and reel

1 Pin description

Figure 2. Pin configuration



Note: The adjacent pins have the same AMR to increase the robustness of the IC against accidental short circuit among pins.

Table 2. Pin description

n.	Name	Function
1	Isense	Inverting input of the current loop op-amp. The pin is tied to the cold end of the current sense resistor through a decoupling resistor.
2	GND	Ground. Return of the bias current of the device. 0 V reference for all voltages. The pin should be tied as close to the ground output terminal of the converter as possible to minimize load current effect on the voltage regulation setpoint.
3	Vctrl	Inverting input of the voltage loop op-amp. The pin is tied to the mid-point of a resistor divider that senses the output voltage.
4	Ictrl	Non-inverting input of the current loop op-amp. It is tied directly to the hot (negative) end of the current sense resistor
5	OUT	Common open-drain output of the two internal op-amps. The pin, able to sink current only, is connected to the branch of the optocoupler's photodiode to transmit the error signal to the primary side.
6	Vcc	Supply Voltage of the device. A small bypass capacitor (0.1 μF typ.) to GND, located as close to IC's pins as possible, might be useful to get a clean supply voltage.

2 Maximum ratings

Table 3. Absolute maximum ratings

Symbol	Pin	Parameter	Value	Unit
Vcc	6	Dc supply voltage	-0.3 to 38	V
Vout	5	Open-drain voltage	-0.3 to Vcc	V
Iout	5	Max sink current	20	mA
Ictrl	4	Analog input	-0.3 to Vcc	V
Isense	1	Analog input	-0.3 to 3.3	V
Vctrl	3	Analog input	-0.3 to 3.3	V

Table 4. Thermal data

Symbol	Parameter	Value	Unit
R _{thJA}	Thermal resistance, junction-to-ambient	250	°C/W
T _{jop}	Junction temperature operating range	-40 to 150	°C
T _{STG}	Storage temperature	-55 to 150	

3 Typical application schematic

Figure 3. Typical application schematic

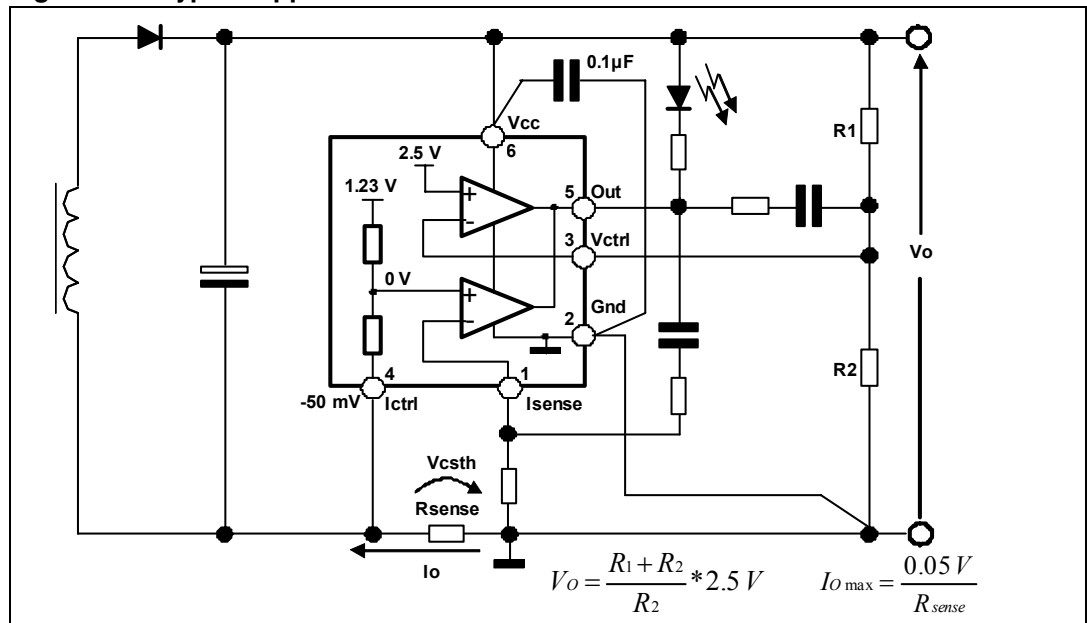

4 Electrical characteristics

-25 °C < T_J < 125 °C, V_{CC} = 20 V; unless otherwise specified

Table 5. Electrical characteristics

Symbol	Parameter	Test condition	Min.	Typ.	Max.	Unit
Device supply						
V _{cc}	Voltage operating range		3.5		36	V
I _{cc}	Quiescent current (I _{ctrl} = I _{sense} = 0 V, OUT = open)			200	300	µA
Voltage control loop op-amp						
G _{m_v}	Transconductance (sink current only) ⁽¹⁾		1	3.5		S
V _{ctrl}	Voltage reference default value ⁽²⁾	T _J = 25 °C	2.488	2.5	2.512	V
			2.48		2.52	
I _{bias}	Inverting input bias current			25		nA
Current control loop						
G _{m_i}	Transconductance (sink current only) ⁽³⁾		1.5	7		S
V _{csth}	Current sense threshold V _{csth} = V _(Isense) - V _(Ictrl) ⁽⁴⁾ @ I _(Iout) = 1 mA		46	50	54	mV
I _{bias}	Non-inverting input source current @ V(Ictrl) = -50 mV			6		µA
Output stage						
V _{OUTlow}	Low output level @ 2 mA sink current			200	400	mV

1. If the voltage on V_{ctrl} (the negative input of the amplifier) is higher than the positive amplifier input, and it is increased by 1 mV, the sinking current at the output OUT is increased by 3.5 mA.
2. The internal voltage reference is set at 2.5 V. The voltage control loop precision takes into account the cumulative effects of the internal voltage reference deviation as well as the input offset voltage of the transconductance operational amplifier. The internal Voltage Reference is fixed by bandgap, and trimmed to 0.48 % accuracy at room temperature.
3. When the positive input at I_{ctrl} is lower than -50 mV, and the voltage is decreased by 1 mV, the sinking current at the output out is increased by 7 mA.
4. Considering I_{ctrl} pin directly connected to the hot (negative) end of the current sense resistor and I_{sense} pin connected to the cold end of the current sense resistor through a decoupling resistor (see fig.3), the internal current sense threshold is triggered when the voltage on pin I_{ctrl} is -50 mV. The current loop reference precision takes into account the cumulative effects of the internal voltage reference deviation as well as the input offset voltage of the transconductance operational amplifier.

5 Application information

Figure 4. Application information

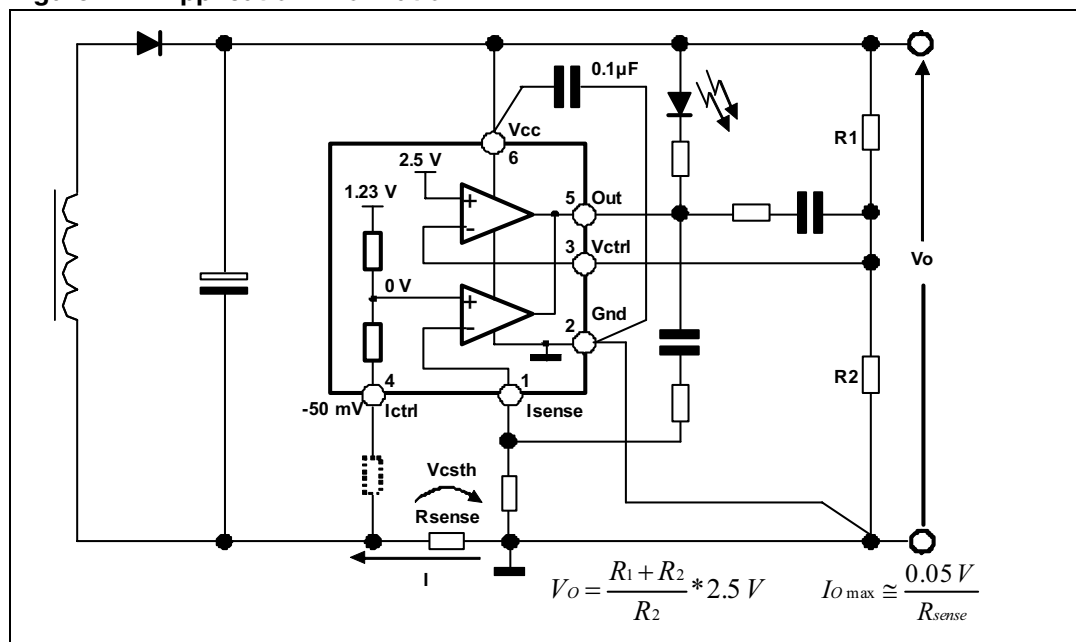

Note: A 15 Ω resistor in series to Ictrl pin helps to protect the IC in case of negative voltage that exceed the AMR of Ictrl pin.

As example a potential dangerous phenomenon could happen during converter output short-circuit.

Consider the steady state operation of the circuit during voltage mode regulation (i.e. the output is at its nominal voltage). The output capacitor is fully charged at V_o . If an abrupt short (i.e. with negligible impedance) is applied at the output, instantly the positive pin of the electrolytic capacitor is connected to the SEA05 ground. Since the capacitor acts like a battery, all its voltage is applied across the R_{sense} pin and therefore the Ictrl pin is pulled down to $-V_o$. This could damage the IC in case the Ictrl pin AMR is violated.

In reality the short is not so severe because it has a some impedance, the electrolytic capacitor has an ESR and it starts discharging as soon as the short is applied. The Ictrl pin is brought to a negative voltage anyway. The pin internal structure has been design to be robust against negative voltage but, since the severity of this phenomenon is proportional to the output voltage, for some applications an external resistor in series with Ictrl pin helps protect the IC.

The resistor added in series with Ictrl pin introduces an error in the current sense threshold voltage.

This error can be calculated considering the Ictrl pin current: this current multiplied by the value of the external resistor gives the current sense threshold variation.

As example if we add a 15 Ω resistor in series to Ictrl pin, we have

I_{ctrl} current = I_{bias} = 6 µA and therefore the error

$6 \mu\text{A} \times 15 \Omega = 80 \mu\text{V}$, the error is $80 \mu\text{V} / 50 \text{mV} = 0.16\%$

6 Voltage and current control

6.1 Voltage control

The voltage loop is controlled via a first transconductance operational amplifier, the voltage divider R1, R2, and the optocoupler which is directly connected to the output. Its possible to choose the values of R1 and R2 resistors using Equation 1-2:

Equation 1

$$V_o = V_{ctrl} * \frac{(R_1 + R_2)}{R_2}$$

Equation 2

$$R_1 = R_2 * \frac{(V_o - V_{ctrl})}{V_{ctrl}}$$

where V_o is the desired output voltage.

As an example, with $R_1 = 100 \text{ k}\Omega$ and $R_2 = 15 \text{ k}\Omega$ $V_o = 19.17 \text{ V}$

6.2 Current control

The current loop is controlled via the second trans-conductance operational amplifier, the sense resistor R_{sense} , and the optocoupler. The control equation verifies:

Equation 3

$$R_{sense} * I_{o_{max}} = V_{csth}$$

Equation 4

$$R_{sense} = \frac{V_{csth}}{I_{o_{max}}}$$

where $I_{o_{max}}$ is the desired limited current, and V_{csth} is the threshold voltage for the current control loop.

As an example, with $I_{o_{max}} = 1 \text{ A}$, $V_{csth} = 50 \text{ mV}$, then $R_{sense} = 50 \text{ m}\Omega$.

Note that the R_{sense} resistor should be chosen taking into account the maximum dissipation (P_{lim}) through it during full load operation.

Equation 5

$$P_{Lim} = V_{csth} \cdot I_{o_{max}}$$

As an example, with $I_{o_{max}} = 1 \text{ A}$, and $V_{csth} = 50 \text{ mV}$, $P_{lim} = 50 \text{ mW}$.

Therefore, for most adaptor and battery charger applications, it is suitable a low power resistor to make the current sensing function.

V_{csth} threshold is achieved internally by a voltage divider tied to an internal voltage reference. Its middle point is tied to the positive input of the current control operational amplifier, and its foot has to be connected to lower potential point of the sense resistor as shown in [Figure 4](#). The resistors of this voltage divider are matched to provide the best possible precision. The current sinking outputs of the two trans-conductance operational amplifiers are common (to the output of the IC). This makes an ORing function which ensures that whenever the current or the voltage reaches too high values, the optocoupler is activated.

The relation between the controlled current and the controlled output voltage can be described with a square characteristic as shown in the following V/I output-power graph. (with power supply of the device independent from the output voltage)

Figure 5. Output voltage versus output current

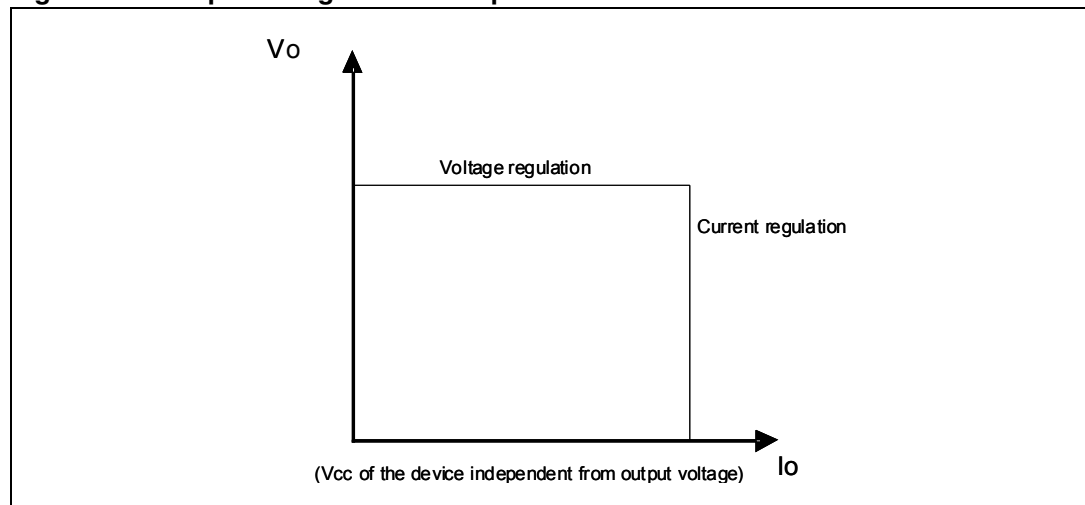

7 Compensation

The voltage control trans-conductance operational amplifier can be fully compensated. Both of its output and negative input are directly accessible for external compensation components as shown in [Figure 4](#).

8 Package mechanical data

In order to meet environmental requirements, ST offers these devices in different grades of ECOPACK[®] packages, depending on their level of environmental compliance. ECOPACK[®] specifications, grade definitions and product status are available at: www.st.com. ECOPACK[®] is an ST trademark.

Table 6. SOT23-6L mechanical data

Dim.	mm.			inch		
	Min.	Typ.	Max.	Min.	Typ.	Max.
A		0.9	1.45		0.035	0.057
A1		0	0.1		0	0.0039
A2		0.9	1.3		0.035	0.0512
b		0.35	0.5		0.014	0.02
c		0.09	0.2		0.004	0.008
D		2.8	3.05		0.11	0.120
E		1.5	1.75		0.059	0.0689
e	0.95			0.037		
H		2.6	3		0.102	0.118
L		0.1	0.6		0.004	0.024
θ (degrees)		0°	10°		0°	10°

Note: Dimensions per JEDEC MO178AB

Figure 6. SOT23-6L package dimensions

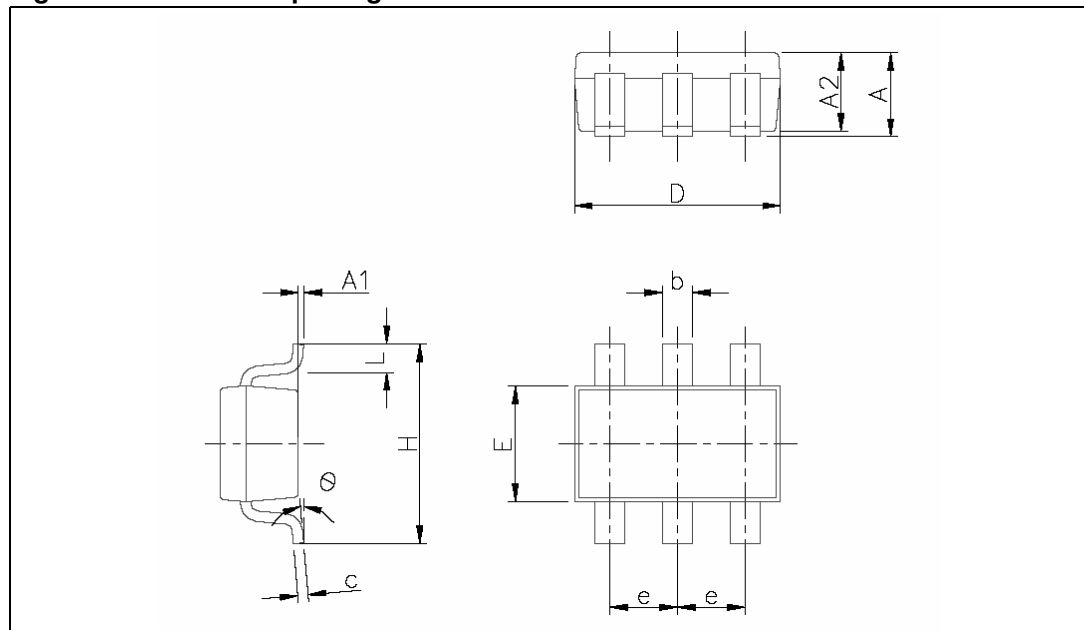

9 Revision history

Table 7. Document revision history

Date	Revision	Changes
26-Apr-2010	1	Initial release.

Please Read Carefully:

Information in this document is provided solely in connection with ST products. STMicroelectronics NV and its subsidiaries ("ST") reserve the right to make changes, corrections, modifications or improvements, to this document, and the products and services described herein at any time, without notice.

All ST products are sold pursuant to ST's terms and conditions of sale.

Purchasers are solely responsible for the choice, selection and use of the ST products and services described herein, and ST assumes no liability whatsoever relating to the choice, selection or use of the ST products and services described herein.

No license, express or implied, by estoppel or otherwise, to any intellectual property rights is granted under this document. If any part of this document refers to any third party products or services it shall not be deemed a license grant by ST for the use of such third party products or services, or any intellectual property contained therein or considered as a warranty covering the use in any manner whatsoever of such third party products or services or any intellectual property contained therein.

UNLESS OTHERWISE SET FORTH IN ST'S TERMS AND CONDITIONS OF SALE ST DISCLAIMS ANY EXPRESS OR IMPLIED WARRANTY WITH RESPECT TO THE USE AND/OR SALE OF ST PRODUCTS INCLUDING WITHOUT LIMITATION IMPLIED WARRANTIES OF MERCHANTABILITY, FITNESS FOR A PARTICULAR PURPOSE (AND THEIR EQUIVALENTS UNDER THE LAWS OF ANY JURISDICTION), OR INFRINGEMENT OF ANY PATENT, COPYRIGHT OR OTHER INTELLECTUAL PROPERTY RIGHT.

UNLESS EXPRESSLY APPROVED IN WRITING BY AN AUTHORIZED ST REPRESENTATIVE, ST PRODUCTS ARE NOT RECOMMENDED, AUTHORIZED OR WARRANTED FOR USE IN MILITARY, AIR CRAFT, SPACE, LIFE SAVING, OR LIFE SUSTAINING APPLICATIONS, NOR IN PRODUCTS OR SYSTEMS WHERE FAILURE OR MALFUNCTION MAY RESULT IN PERSONAL INJURY, DEATH, OR SEVERE PROPERTY OR ENVIRONMENTAL DAMAGE. ST PRODUCTS WHICH ARE NOT SPECIFIED AS "AUTOMOTIVE GRADE" MAY ONLY BE USED IN AUTOMOTIVE APPLICATIONS AT USER'S OWN RISK.

Resale of ST products with provisions different from the statements and/or technical features set forth in this document shall immediately void any warranty granted by ST for the ST product or service described herein and shall not create or extend in any manner whatsoever, any liability of ST.

ST and the ST logo are trademarks or registered trademarks of ST in various countries.

Information in this document supersedes and replaces all information previously supplied.

The ST logo is a registered trademark of STMicroelectronics. All other names are the property of their respective owners.

© 2010 STMicroelectronics - All rights reserved

STMicroelectronics group of companies

Australia - Belgium - Brazil - Canada - China - Czech Republic - Finland - France - Germany - Hong Kong - India - Israel - Italy - Japan - Malaysia - Malta - Morocco - Philippines - Singapore - Spain - Sweden - Switzerland - United Kingdom - United States of America

www.st.com

Компания «Океан Электроники» предлагает заключение долгосрочных отношений при поставках импортных электронных компонентов на взаимовыгодных условиях!

Наши преимущества:

- Поставка оригинальных импортных электронных компонентов напрямую с производств Америки, Европы и Азии, а так же с крупнейших складов мира;
- Широкая линейка поставок активных и пассивных импортных электронных компонентов (более 30 млн. наименований);
- Поставка сложных, дефицитных, либо снятых с производства позиций;
- Оперативные сроки поставки под заказ (от 5 рабочих дней);
- Экспресс доставка в любую точку России;
- Помощь Конструкторского Отдела и консультации квалифицированных инженеров;
- Техническая поддержка проекта, помощь в подборе аналогов, поставка прототипов;
- Поставка электронных компонентов под контролем ВП;
- Система менеджмента качества сертифицирована по Международному стандарту ISO 9001;
- При необходимости вся продукция военного и аэрокосмического назначения проходит испытания и сертификацию в лаборатории (по согласованию с заказчиком);
- Поставка специализированных компонентов военного и аэрокосмического уровня качества (Xilinx, Altera, Analog Devices, Intersil, Interpoint, Microsemi, Actel, Aeroflex, Peregrine, VPT, Syfer, Eurofarad, Texas Instruments, MS Kennedy, Miteq, Cobham, E2V, MA-COM, Hittite, Mini-Circuits, General Dynamics и др.);

Компания «Океан Электроники» является официальным дистрибьютором и эксклюзивным представителем в России одного из крупнейших производителей разъемов военного и аэрокосмического назначения «JONHON», а так же официальным дистрибьютором и эксклюзивным представителем в России производителя высокотехнологичных и надежных решений для передачи СВЧ сигналов «FORSTAR».



JONHON

«JONHON» (основан в 1970 г.)

Разъемы специального, военного и аэрокосмического назначения:

(Применяются в военной, авиационной, аэрокосмической, морской, железнодорожной, горно- и нефтедобывающей отраслях промышленности)

«FORSTAR» (основан в 1998 г.)

ВЧ соединители, коаксиальные кабели,
кабельные сборки и микроволновые компоненты:

(Применяются в телекоммуникациях гражданского и специального назначения, в средствах связи, РЛС, а так же военной, авиационной и аэрокосмической отраслях промышленности).



Телефон: 8 (812) 309-75-97 (многоканальный)

Факс: 8 (812) 320-03-32

Электронная почта: ocean@oceanchips.ru

Web: <http://oceanchips.ru/>

Адрес: 198099, г. Санкт-Петербург, ул. Калинина, д. 2, корп. 4, лит. А