

## NCP1421/2 Reference Designs for High-Power White LED Flash Applications

Prepared by: Jim Hill  
ON Semiconductor



ON Semiconductor®

<http://onsemi.com>

### APPLICATION NOTE

#### Abstract

The attached design illustrates how the NCP1421/2 boost converters can be configured as a current regulator for biasing high current white LED's. Typical boost converters, such as these, have a reference voltage of 1.2 V. Since this is a current sourcing application, the more straightforward approach of directly sensing the boost converter's reference voltage ( $V_{ref}$ ), which is 1.2 V, across a sense resistor would dissipate too much power at the currents required to drive high-power White LED's. Also, the lot-to-lot forward voltage variation is too high to simply regulate at a fixed voltage with a current limiting resistor. Therefore, this paper describes a technique that reduces both the power loss in the sense resistor and the lot-to-lot variation effect of the LED. This applications shows two implementations of this concept. Figure 1 shows a simple boost converter configured at various current levels and uses the Lumileds LXHL-WW06 white LED. Figure 5 shows a circuit that switches between a low current for focus lighting and high current for the flash and uses the Lumileds LXCL-PWF1 white LED.

#### Overview

The NCP1421 and NCP1422 are monolithic boost converter IC's uniquely suited to power higher current portable applications (600 – 800 mA maximum). Their high switching frequency (up to 1.2 MHz) allows for a low

profile, small sized inductor and output capacitor to be used. Also an integrated disconnect switch provides "true cutoff" by isolating the output from the battery during shutdown. The NCP1421 comes in the 3x5 mm Micro-8 package, and the NCP1422 comes in the 3x3 mm DFN package. Because of these features the NCP1421/2 are well suited to provide current regulation for biasing high current white LED's in portable flash applications. Figure 1 illustrates this circuit.

In summary the reference voltage is split between the current sense resistor, R4, and a divided down voltage from the white LED with resistors R2 and R3. This helps remove some of the dependence of the NCP1421/2's output voltage, and thus current, on the LED's forward voltage,  $V_F$ . This also helps prevent lot-to-lot  $V_F$  variation affecting the LED brightness.

Figure 1 shows a typical circuit which, with the Bill of Materials shown in Table 1, can provide LED currents of 200, 600 and 800 mA. The 200 mA design uses the NCP1422 because of its smaller footprint, and the 600 mA and 800 mA designs use the NCP1421 and NCP1422 respectively to showcase the load current limits of each device.

The higher currents (600 and 800 mA) assume that the LED will be pulsed and not run at steady state. 50 ms pulses on the LBI/EN were used in the analysis of these circuits. The NCP1421/2 takes 1.5 ms (nominal) to turn on after the LBI/EN pin is driven high.

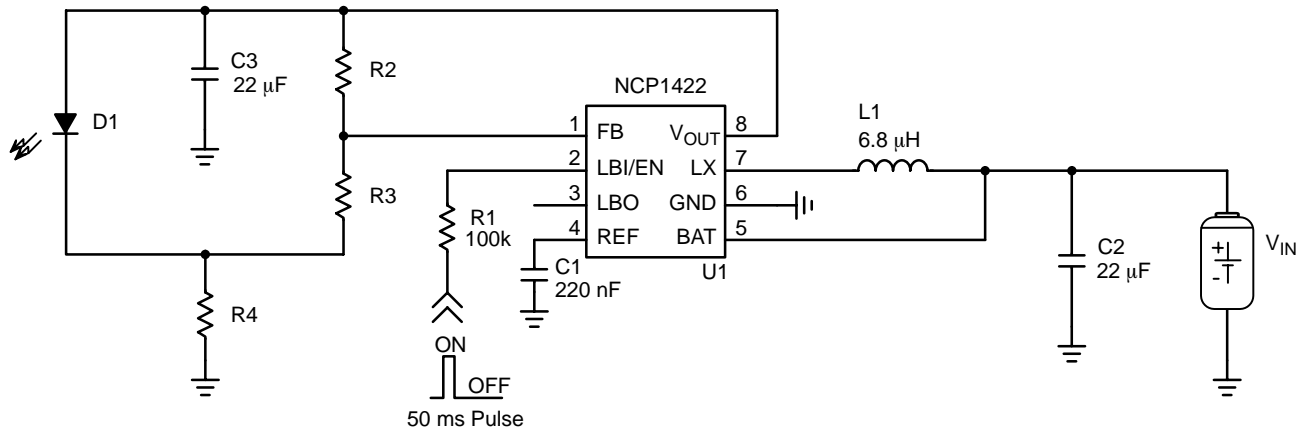

Figure 1. NCP1422 Configured to Drive High Current White LED

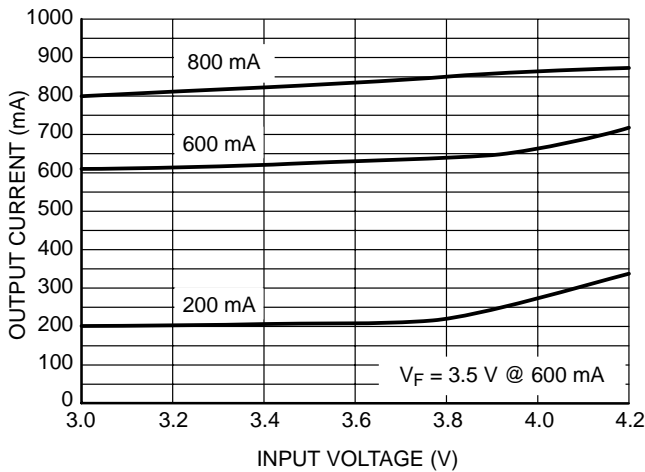

Figure 2. Output Current vs. Input Voltage

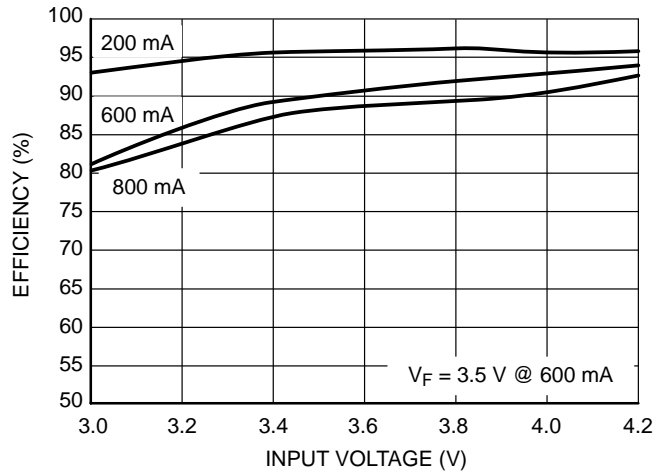

Figure 3. Converter Efficiency vs. Input Voltage

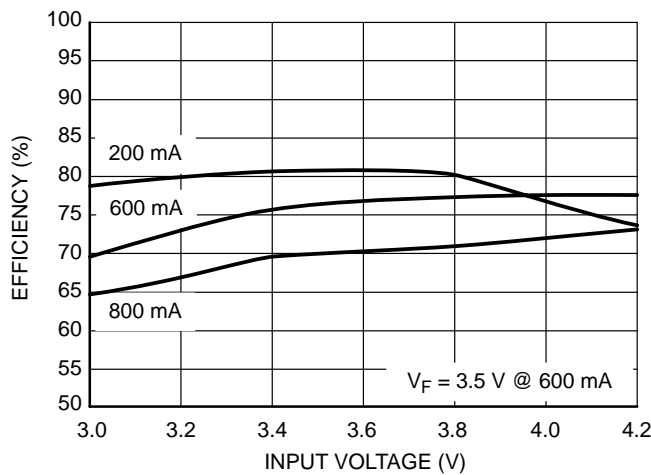

Figure 4. Electrical to Optical Efficiency vs. Input Voltage

**Design Steps**

The following steps show how to determine the critical components for this circuit. (R2, R3, R4, L1) This shows the 600 mA version as an example:

**Step 1:** Let LED current =  $I_D = 600 \text{ mA}$

**Step 2:** From the LED datasheet, let  $V_F = 3.5 \text{ V}$   
(Find value of  $V_F$  at 600 mA).

**Step 3:** Let  $R3 = 100 \text{ k}\Omega$

**Step 4:** Let  $V_{R4} = 0.5 * V_{ref}$  which is 0.6 V. This places equal dependence on  $V_F$  variation and tolerance of the reference and R4. One could increase the output voltage by making the voltage across R4 ( $V_{R4}$ ) larger or decrease power dissipation in R4 by lowering  $V_{R4}$ .

**Step 5:** For  $I_D = 600 \text{ mA}$  and  $V_{R4} = 0.6 \text{ V}$ ,  $R4 = 1.0 \Omega$ .

**Step 6:** Now,  $V_{R4}$  plus the divided voltage off of the LED must equal 1.2 V, and that is 0.6 V

**Step 7:** So,  $R2 = (V_F / (V_{ref} - V_{R4})) * R3 - R3 =$   
 $(3.5 / 0.6) * 100 \text{ k}\Omega - 100 \text{ k}\Omega = 483 \text{ k}\Omega$

**Step 8:** Then choose a standard value of R2 which is close to the above calculated value. Choose  $R2 = 475 \text{ k}\Omega$ .

**Step 9:** Pick input voltage range. These circuits assume a one-cell Li-ion battery pack or a 3-cell NiMH pack so the

input voltage is assumed to be 3.6 V and has been optimized around this point.

**Step 10:** Determine output voltage. Output voltage will be  $V_F + V_{R4} = 4.1 \text{ V}$  One can use the 3.6 V as  $V_{in}$  chosen above because this circuit decreases LED current as  $V_F$  increases from the designed value. This is shown by the following equation:  $I_D = 1/R4 * (V_{ref} - V_F * (R3/R2 + R3))$  Conversely it increases current as  $V_F$  decreases from the designed value, but then the difference between  $V_{in}$  and  $V_{out}$  is less, so the peak current is reduced.

**Step 11:** Use the NCP1421 or NCP1422 datasheet to determine the appropriate L1, C1, and C2. For this application, 6.8  $\mu\text{H}$ , 22  $\mu\text{F}$ , and 22  $\mu\text{F}$  were found to work well over the load and line range.

**Step 12:** Determine the inductor saturation current. For this circuit  $V_{in \text{ min}} = 3 \text{ V}$ :  $I_{Lavg} = I_{out} / (1-D)$  where  $D = (1 - V_{in}/V_{out})$ . Therefore  $I_{Lavg} = 600 \text{ mA} / (1 - (1 - V_{in}/V_{out})) = 840 \text{ mA}$

**Step 13:** Add 20% margin to this  $I_{Lavg}$  and pick an inductor with an  $I_{sat} > 1.0 \text{ A}$ .

# AND8171/D

Finally, Figure 5 shows a Focus/Flash application where the NCP1422 drives one LED at 200 and 600 mA. An

external MOSFET changes the R4 resistance to vary the LED current. 50 ms pulses were used for this design.

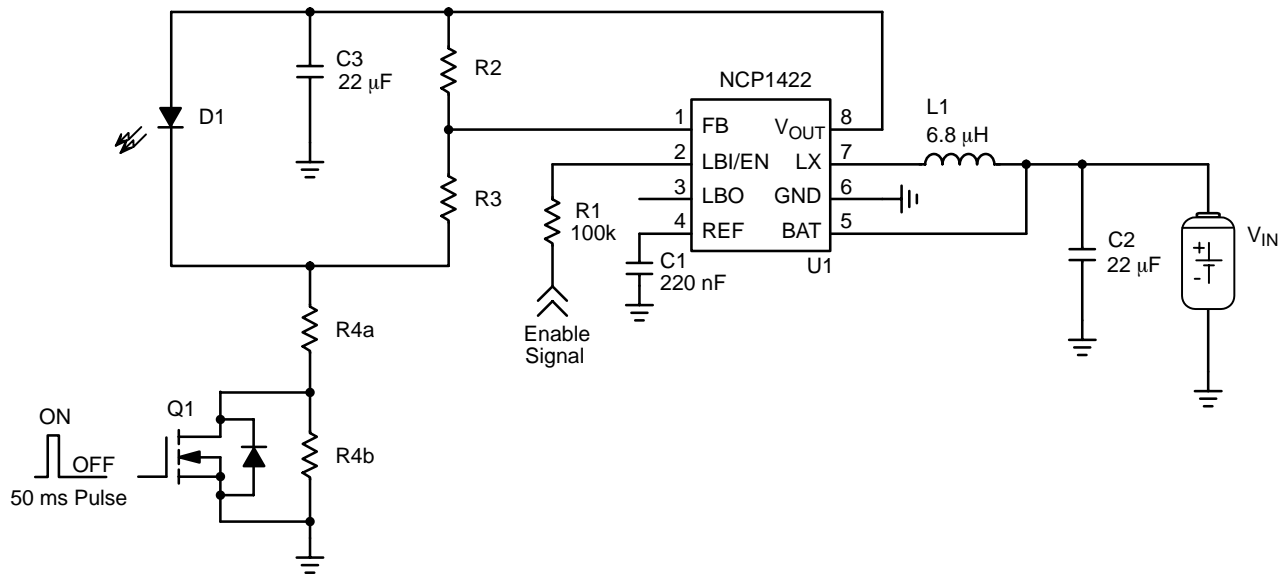

Figure 5. 200/600 mA Focus/Flash Application

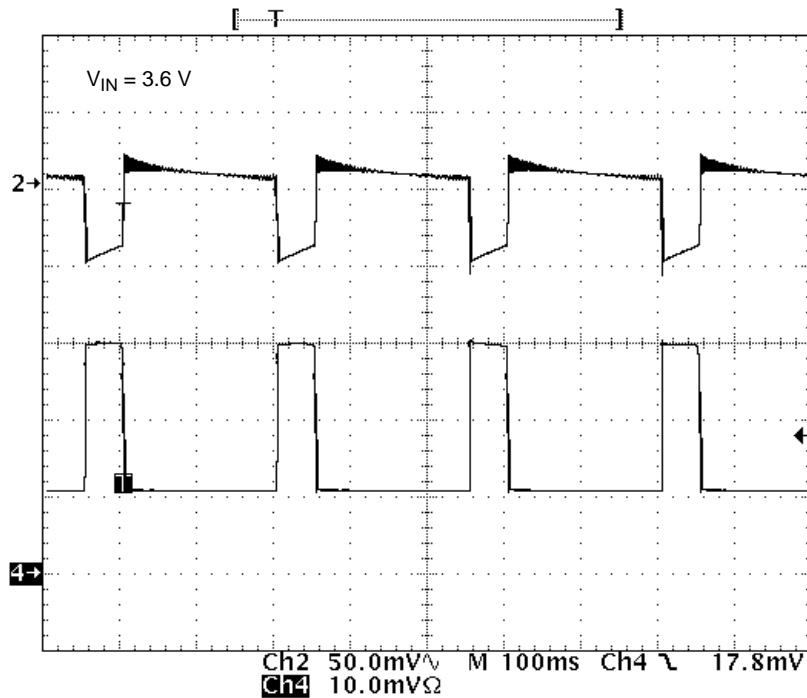

Figure 6. LED Current and  $V_{in}$  Ripple Voltage with 200/600 mA Focus/Flash Pulse (CH2 =  $V_{in}$ , ac-coupled @ 50 mV/div; CH4 =  $I_{LED}$  @ 200 mA/div)

# AND8171/D

**Table 1. Bill of Materials for Figure 1**

Ref	Part Number	Description	PCB Footprint	Manufacturer
<b>200 mA Design</b>				
U1	NCP1422MNR2	NCP1422 Boost Converter	DFN-10 (3 x 3 mm)	ON Semiconductor
D1	LXHL-WW06	White LED		Lumileds
L1	VLP5610T-6R8	6.8 $\mu$ H Inductor	(5.6 x 5.0 x 1.0 mm)	TDK
R1	CRCW0402104....	100 k $\Omega$	0402	Vishay
R2	CRCW04025603....	560 k $\Omega$	0402	Vishay
R3	CRCW04021503....	150 k $\Omega$	0402	Vishay
R4	DCRCW12062R70...	2.7 $\Omega$	1206	Vishay
C1	C1608X5R1A224K	220 nF	0603	TDK
C2	C2012X5R0J226M	22 $\mu$ F / 6.3 V (X5R Ceramic)	0805	TDK
C3	C2012X5R0J226M	22 $\mu$ F / 6.3 V (X5R Ceramic)	0805	TDK
<b>600 mA Design</b>				
U1	NCP1421DMR2	NCP1421 Boost Converter	Micro-8 (3 x 5 mm)	ON Semiconductor
D1	LXHL-WW06	White LED		Lumileds
L1	VLP6214T-6R8	6.8 $\mu$ H Inductor	(6.2 x 5.8 x 1.4 mm)	TDK / Coilcraft
R1	CRCW0402104....	100 k $\Omega$	0402	Vishay
R2	CRCW04025603....	475 k $\Omega$	0402	Vishay
R3	CRCW04021503....	100 k $\Omega$	0402	Vishay
R4	CRCW12061R00...	1.0 $\Omega$	1206	Vishay
C1	C1608X5R1A224K	220 nF	0603	TDK
C2	C2012X5R0J226M	22 $\mu$ F / 6.3 V (X5R Ceramic)	0805	TDK
C3	C2012X5R0J226M	22 $\mu$ F / 6.3 V (X5R Ceramic)	0805	TDK
<b>800 mA Design</b>				
U1	NCP1422DMR2	NCP1422 Boost Converter	DFN-10 (3 x 3 mm)	ON Semiconductor
D1	LXHL-WW06	White LED		Lumileds
L1	VLP6214T-6R8	6.8 $\mu$ H Inductor	(6.2 x 5.8 x 1.4 mm)	TDK
R1	CRCW0402104....	100 k $\Omega$	0402	Vishay
R2	CRCW04025603....	750 k $\Omega$	0402	Vishay
R3	CRCW04021503....	150 k $\Omega$	0402	Vishay
R4	CRCW12061R50...*	0.75 $\Omega$	1206	Vishay
C1	C1608X5R1A224K	220 nF	0603	TDK
C2	C2012X5R0J226M	22 $\mu$ F / 6.3 V (X5R Ceramic)	0805	TDK
C3	C2012X5R0J226M	22 $\mu$ F / 6.3 V (X5R Ceramic)	0805	TDK

\*2 – 1.5  $\Omega$  resistors were used in parallel.

## AND8171/D

**Table 2. Bill of Materials for Figure 5**

200/600 mA Design				
U1	NCP1422MNR2	NCP1422 Boost Converter	DFN-10 (3 x 3 mm)	ON Semiconductor
D1	LXCL-PWF1	White LED	(1.64 x 2.04 x 0.9 mm)	Lumileds
Q1	NTJS3157N	N-Channel MOSFET	SC-88	ON Semiconductor
L1	VLP5610-6R8	6.8 $\mu$ H Inductor	(5.6 x 5.0 x 1.0 mm)	TDK
R1	CRCW0402104....	100 k $\Omega$	0402	Vishay
R2	CRCW04025603....	475 k $\Omega$	0402	Vishay
R3	CRCW04021503....	100 k $\Omega$	0402	Vishay
R4a	CRCW12062R00...*	1.0 $\Omega$	1206	Vishay
R4b	CRCW12062R00...	2.0 $\Omega$	1206	Vishay
C1	C1608X5R1A224K	220 nF	0603	TDK
C2	C2012X5R0J226M	22 $\mu$ F / 6.3 V (X5R Ceramic)	0805	TDK
C3	C2012X5R0J226M	22 $\mu$ F / 6.3 V (X5R Ceramic)	0805	TDK

\*2 – 2.0  $\Omega$  resistors were used in parallel.

**ON Semiconductor** and  are registered trademarks of Semiconductor Components Industries, LLC (SCILLC). SCILLC reserves the right to make changes without further notice to any products herein. SCILLC makes no warranty, representation or guarantee regarding the suitability of its products for any particular purpose, nor does SCILLC assume any liability arising out of the application or use of any product or circuit, and specifically disclaims any and all liability, including without limitation special, consequential or incidental damages. "Typical" parameters which may be provided in SCILLC data sheets and/or specifications can and do vary in different applications and actual performance may vary over time. All operating parameters, including "Typicals" must be validated for each customer application by customer's technical experts. SCILLC does not convey any license under its patent rights nor the rights of others. SCILLC products are not designed, intended, or authorized for use as components in systems intended for surgical implant into the body, or other applications intended to support or sustain life, or for any other application in which the failure of the SCILLC product could create a situation where personal injury or death may occur. Should Buyer purchase or use SCILLC products for any such unintended or unauthorized application, Buyer shall indemnify and hold SCILLC and its officers, employees, subsidiaries, affiliates, and distributors harmless against all claims, costs, damages, and expenses, and reasonable attorney fees arising out of, directly or indirectly, any claim of personal injury or death associated with such unintended or unauthorized use, even if such claim alleges that SCILLC was negligent regarding the design or manufacture of the part. SCILLC is an Equal Opportunity/Affirmative Action Employer. This literature is subject to all applicable copyright laws and is not for resale in any manner.

## PUBLICATION ORDERING INFORMATION

### LITERATURE FULFILLMENT:

Literature Distribution Center for ON Semiconductor  
P.O. Box 61312, Phoenix, Arizona 85082-1312 USA  
**Phone:** 480-829-7710 or 800-344-3860 Toll Free USA/Canada  
**Fax:** 480-829-7709 or 800-344-3867 Toll Free USA/Canada  
**Email:** [orderlit@onsemi.com](mailto:orderlit@onsemi.com)

**N. American Technical Support:** 800-282-9855 Toll Free  
USA/Canada

**Japan:** ON Semiconductor, Japan Customer Focus Center  
2-9-1 Kamimeguro, Meguro-ku, Tokyo, Japan 153-0051  
**Phone:** 81-3-5773-3850

**ON Semiconductor Website:** <http://onsemi.com>

**Order Literature:** <http://www.onsemi.com/litorder>

For additional information, please contact your  
local Sales Representative.

Компания «Океан Электроники» предлагает заключение долгосрочных отношений при поставках импортных электронных компонентов на взаимовыгодных условиях!

Наши преимущества:

- Поставка оригинальных импортных электронных компонентов напрямую с производств Америки, Европы и Азии, а так же с крупнейших складов мира;
- Широкая линейка поставок активных и пассивных импортных электронных компонентов (более 30 млн. наименований);
- Поставка сложных, дефицитных, либо снятых с производства позиций;
- Оперативные сроки поставки под заказ (от 5 рабочих дней);
- Экспресс доставка в любую точку России;
- Помощь Конструкторского Отдела и консультации квалифицированных инженеров;
- Техническая поддержка проекта, помощь в подборе аналогов, поставка прототипов;
- Поставка электронных компонентов под контролем ВП;
- Система менеджмента качества сертифицирована по Международному стандарту ISO 9001;
- При необходимости вся продукция военного и аэрокосмического назначения проходит испытания и сертификацию в лаборатории (по согласованию с заказчиком);
- Поставка специализированных компонентов военного и аэрокосмического уровня качества (Xilinx, Altera, Analog Devices, Intersil, Interpoint, Microsemi, Actel, Aeroflex, Peregrine, VPT, Syfer, Eurofarad, Texas Instruments, MS Kennedy, Miteq, Cobham, E2V, MA-COM, Hittite, Mini-Circuits, General Dynamics и др.);

Компания «Океан Электроники» является официальным дистрибьютором и эксклюзивным представителем в России одного из крупнейших производителей разъемов военного и аэрокосмического назначения «JONHON», а так же официальным дистрибьютором и эксклюзивным представителем в России производителя высокотехнологичных и надежных решений для передачи СВЧ сигналов «FORSTAR».



## JONHON

«JONHON» (основан в 1970 г.)

Разъемы специального, военного и аэрокосмического назначения:

(Применяются в военной, авиационной, аэрокосмической, морской, железнодорожной, горно- и нефтедобывающей отраслях промышленности)

«FORSTAR» (основан в 1998 г.)

ВЧ соединители, коаксиальные кабели,  
кабельные сборки и микроволновые компоненты:

(Применяются в телекоммуникациях гражданского и специального назначения, в средствах связи, РЛС, а так же военной, авиационной и аэрокосмической отраслях промышленности).



Телефон: 8 (812) 309-75-97 (многоканальный)

Факс: 8 (812) 320-03-32

Электронная почта: [ocean@oceanchips.ru](mailto:ocean@oceanchips.ru)

Web: <http://oceanchips.ru/>

Адрес: 198099, г. Санкт-Петербург, ул. Калинина, д. 2, корп. 4, лит. А