

AC/DC Drivers

PWM type DC/DC converter IC Included 650V MOSFET

BM2PXX1F Series

•General

The PWM type DC/DC converter (BM2PXX1F) for AC/DC provide an optimum system for all products that include an electrical outlet.

BM2PXX1F supports both isolated and non-isolated devices, enabling simpler design of various types of low-power electrical converters.

BM2PXX1F built in a HV starter circuit that tolerates 650V, it contributes to low-power consumption.

With current detection resistors as external devices, a higher degree of design freedom is achieved. Since current mode control is utilized, current is restricted in each cycle and excellent performance is demonstrated in bandwidth and transient response.

The switching frequency is 65 kHz. At light load, the switching frequency is reduced and high efficiency is achieved.

A frequency hopping function is also on chip, which contributes to low EMI.

We can design easily, because BM2PXX1F includes the switching MOSFET.

•Basic specifications

■ Operating Power Supply Voltage Range:
VCC 8.9V to 26.0V DRAIN : ~650V

■ Operating Current: Normal Mode
BM2P051F: 0.60mA (Typ.)
BM2P091F: 0.50mA (Typ.)
Burst Mode: 0.40mA (Typ.)

Oscillation Frequency: 65 kHz (Typ.)

■ Operating Temperature: -40 °C to +105 °C

■ MOSFET ON Resistance:
BM2P051F: 4.0Ω (Typ.)
BM2P091F: 8.5Ω (Typ.)

•Application circuit

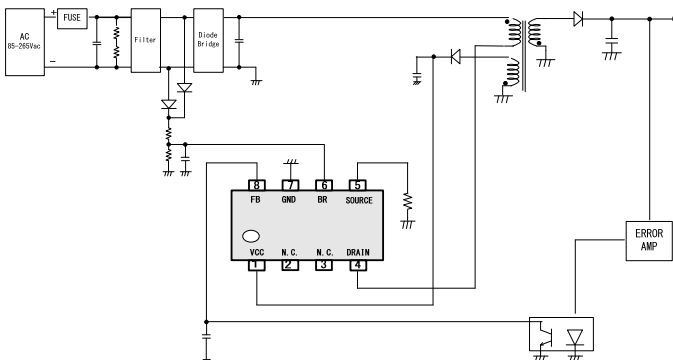

Figure 1. Application circuit

•Features

- PWM frequency : 65kHz
- PWM current mode method
- Burst operation when load is light
- Frequency reduction function
- Built-in 650V start circuit
- Built-in 650V switching MOSFET
- VCC pin under voltage protection
- VCC pin overvoltage protection
- SOURCE pin Open protection
- SOURCE pin Short protection
- SOURCE pin Leading-Edge-Blanking function
- Per-cycle over current protection circuit
- Soft start
- Secondary Over current protection circuit
- BR pin AC input low voltage protection
- BR pin AC input high voltage protection

•Package
SOP8

W (Typ.) x D (Typ.) x H (Max.)
5.00mm x 6.20mm x 1.71mm



•Applications

AC adapters and household appliances (vacuum cleaners, humidifiers, air cleaners, air conditioners, IH cooking heaters, rice cookers, etc.)

•Line up

Product	MOSFET ON resistor
BM2P051F	4.0Ω
BM2P091F	8.5Ω

●Absolute Maximum Ratings (Ta=25°C)

Parameter	Symbol	Rating	Unit	Conditions
Maximum applied voltage 1	V _{max1}	-0.3~30	V	VCC
Maximum applied voltage 2	V _{max2}	-0.3~6.5	V	SOURCE, FB, BR
Maximum applied voltage 3	V _{max3}	650	V	DRAIN
Drain current pulse	I _{DP}	2.60	A	P _w =10us, Duty cycle=1% (BM2P051F)
Drain current pulse	I _{DP}	1.30	A	P _w =10us, Duty cycle=1% (BM2P091F)
Allowable dissipation	P _d	563	mW	
Operating temperature range	T _{opr}	-40 ~ +105	°C	
MAX junction temperature	T _{JMAX}	150	°C	
Storage temperature range	T _{str}	-55 ~ +150	°C	

(Note1) SOP8 : When mounted (on 70 mm × 70 mm, 1.6 mm thick, glass epoxy on single-layer substrate).
Reduce to 4.563 mW/°C when Ta = 25°C or above.

●Operating Conditions (Ta=25°C)

Parameter	Symbol	Rating	Unit	Conditions
Power supply voltage range 1	V _{CC}	8.9~26.0	V	VCC pin voltage
Power supply voltage range 2	V _{DRAIN}	~650	V	DRAIN pin voltage

●Electrical Characteristics of MOSFET part (Unless otherwise noted, Ta = 25°C, VCC = 15 V)

Parameter	Symbol	Specifications			Unit	Conditions
		Minimum	Standard	Maximum		
[MOSFET Block]						
Between drain and source voltage	V _{(BR)DDS}	650	-	-	V	I _D =1mA / V _{GS} =0V
Drain leak current	I _{DSS}	-	-	100	uA	V _{DS} =650V / V _{GS} =0V
On resistance	R _{DS(ON)}	-	4.0	5.5	Ω	I _D =0.25A / V _{GS} =10V (BM2P051F)
On resistance	R _{DS(ON)}	-	8.5	12.0	Ω	I _D =0.25A / V _{GS} =10V (BM2P091F)

●Electrical Characteristics (Unless otherwise noted, Ta = 25°C, VCC = 15 V)

Parameter	Symbol	Specifications			Unit	Conditions
		Minimum	Standard	Maximum		
[Circuit current]						
Circuit current (ON) 1	I _{ON1}	410	600	790	μA	BM2P051F, FB=2.0V (at pulse operation)
Circuit current (ON) 1	I _{ON1}	350	500	650	μA	BM2P091F, FB=2.0V (at pulse operation)
Circuit current (ON) 2	I _{ON2}	-	400	500	μA	FB=0.0V(at burst operation)
[VCC protection function]						
VCC UVLO voltage 1	V _{UVLO1}	12.50	13.50	14.50	V	VCC rises
VCC UVLO voltage 2	V _{UVLO2}	7.50	8.20	8.90	V	VCC falls
VCC UVLO hysteresis	V _{UVLO3}	-	5.30	-	V	V _{UVLO3} = V _{UVLO1} - V _{UVLO2}
VCC OVP voltage 1	V _{OVP1}	26.0	27.5	29.0	V	VCC rises
Latch released VCC voltage	V _{LATCH}	-	V _{UVLO2} -0.5	-	V	
VCC Recharge start voltage	V _{CHG1}	7.70	8.70	9.70	V	
VCC Recharge stop voltage	V _{CHG2}	12.00	13.00	14.00	V	
Latch mask time	T _{LATCH}	50	100	150	us	
Thermal shut down temperature	T _{SD}	118	145	-	°C	
[PWM type DCDC driver block]						
Oscillation frequency 1	F _{SW1}	60	65	70	KHz	FB=2.00V
Oscillation frequency 2	F _{SW2}	20	25	30	KHz	FB=0.40V
Frequency hopping width 1	F _{DEL1}	-	4.0	-	KHz	FB=2.0V
Hopping fluctuation frequency	F _{CH}	75	125	175	Hz	
Soft start time 1	T _{SS1}	0.30	0.50	0.70	ms	
Soft start time 2	T _{SS2}	0.60	1.00	1.40	ms	
Soft start time 3	T _{SS3}	1.20	2.00	2.80	ms	
Soft start time 4	T _{SS4}	4.80	8.00	11.20	ms	
Maximum duty	D _{max}	68.0	75.0	82.0	%	
FB pin pull-up resistance	R _{FB}	23	30	37	kΩ	
Δ FB / Δ CS gain	Gain	-	4.00	-	V/V	
FB burst voltage	V _{BST}	0.300	0.400	0.500	V	FB falls
FB voltage of starting Frequency reduction mode	V _{DLT}	1.100	1.250	1.400	V	
FB OLP voltage 1a	V _{FOLP1A}	2.60	2.80	3.00	V	Overload is detected (FB rise)
FB OLP voltage 1b	V _{FOLP1B}	-	2.60	-	V	Overload is detected (FB drop)
FB OLP ON timer	T _{FOLP1}	40	64	88	ms	
FB OLP Start up timer	T _{FOLP2}	26	32	38	ms	
FB OLP OFF timer	T _{FOLP2}	358	512	666	ms	
[Over current detection block]						
Overcurrent detection voltage	V _{CS}	0.380	0.400	0.420	V	Ton=0us
Overcurrent detection voltage SS1	V _{CS_SS1}	-	0.100	-	V	0[ms] ~ Tss1[ms]
Overcurrent detection voltage SS2	V _{CS_SS2}	-	0.150	-	V	TSS1 [ms] ~ TSS2 [ms]
Overcurrent detection voltage SS3	V _{CS_SS3}	-	0.200	-	V	TSS2 [ms] ~ TSS3[ms]
Overcurrent detection voltage SS4	V _{CS_SS4}	-	0.300	-	V	TSS3 [ms] ~ TSS4 [ms]
Leading Edge Blanking Time	T _{LEB}	-	250	-	ns	
Over current detection AC Voltage compensation factor	K _{CS}	12	20	28	mV/us	
SOURCE pin short protection voltage	V _{CSSHT}	0.020	0.050	0.080	V	
[Start circuit block]						
Start current 1	I _{START1}	0.100	0.500	1.000	mA	VCC= 0V
Start current 2	I _{START2}	1.000	3.000	6.000	mA	VCC=10V
OFF current	I _{START3}	-	10	20	uA	Inflow current from Drain pin after UVLO released UVLO. When MOSFET is OFF
Start current switching voltage	V _{SC}	0.800	1.500	2.100	V	

●Electrical Characteristics (Unless otherwise noted, Ta = 25°C, VCC = 15 V)

Parameter	Symbol	Specifications			Unit	Conditions
		Minimum	Standard	Maximum		
[BR pin function]						
BR UVLO detection voltage1	V_{BR1}	0.45	0.50	0.55	V	BR rises
BR UVLO voltage 2	V_{BR2}	0.29	0.35	0.41	V	BR falls
BR UVLO hysteresis	V_{BR3}	-	0.15	-	V	$V_{BR3}=V_{BR1}-V_{BR2}$
BR UVLO detection delay time1	T_{BR1}	50	100	150	us	BR rises
BR UVLO detection delay time2	T_{BR2}	150	256	350	ms	BR falls
BR OVP detection voltage1	V_{BR4}	2.00	2.10	2.20	V	BR rises
BR OVP detection valtage2	V_{BR5}	1.90	2.00	2.10	V	BR falls
BR OVP hysteresis	V_{BR6}	-	0.10	-	V	$V_{BR3}=V_{BR1}-V_{BR2}$
BR OVP detection delay time1	T_{BR3}	50	100	150	us	BR rises
BR OVP detection delay time2	T_{BR4}	50	100	150	us	BR falls

●PIN DESCRIPTIONS

Table 1. Pin Description

NO.	Pin Name	I/O	Function	ESD Diode	
				VCC	
1	VCC	I	Power supply input pin	-	○
2	N.C.	-	-	-	-
3	N.C.	-	-	-	-
4	DRAIN	I/O	MOSFET DRAIN pin	-	-
5	SOURCE	I/O	MOSFET SOURCE pin	○	○
6	BR.	I	Input AV Voltage monitor pin	-	-
7	GND	I/O	GND pin	○	-
8	FB	I	Feedback signal input pin	-	○

●I/O Equivalent Circuit Diagram

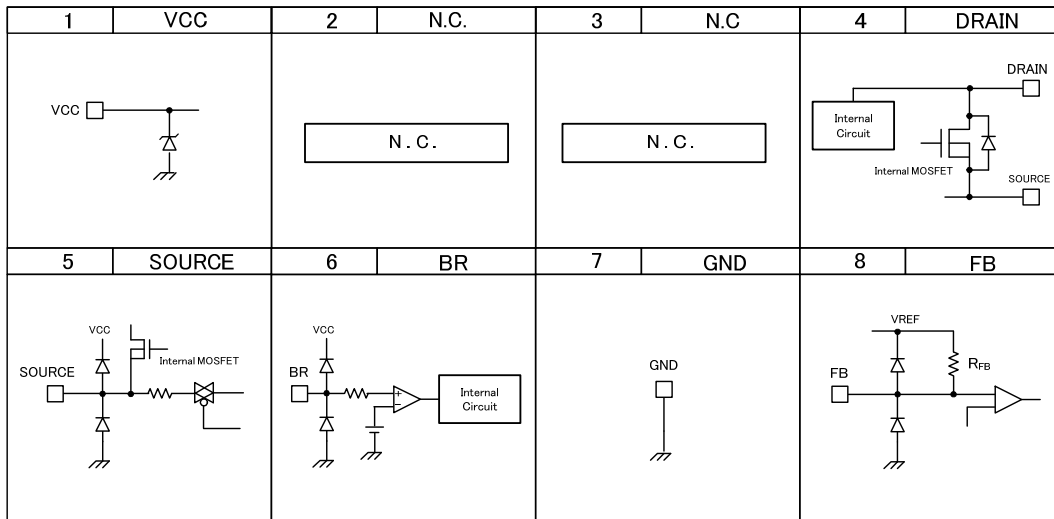

Figure 2. I/O Equivalent Circuit Diagram

•Block Diagram

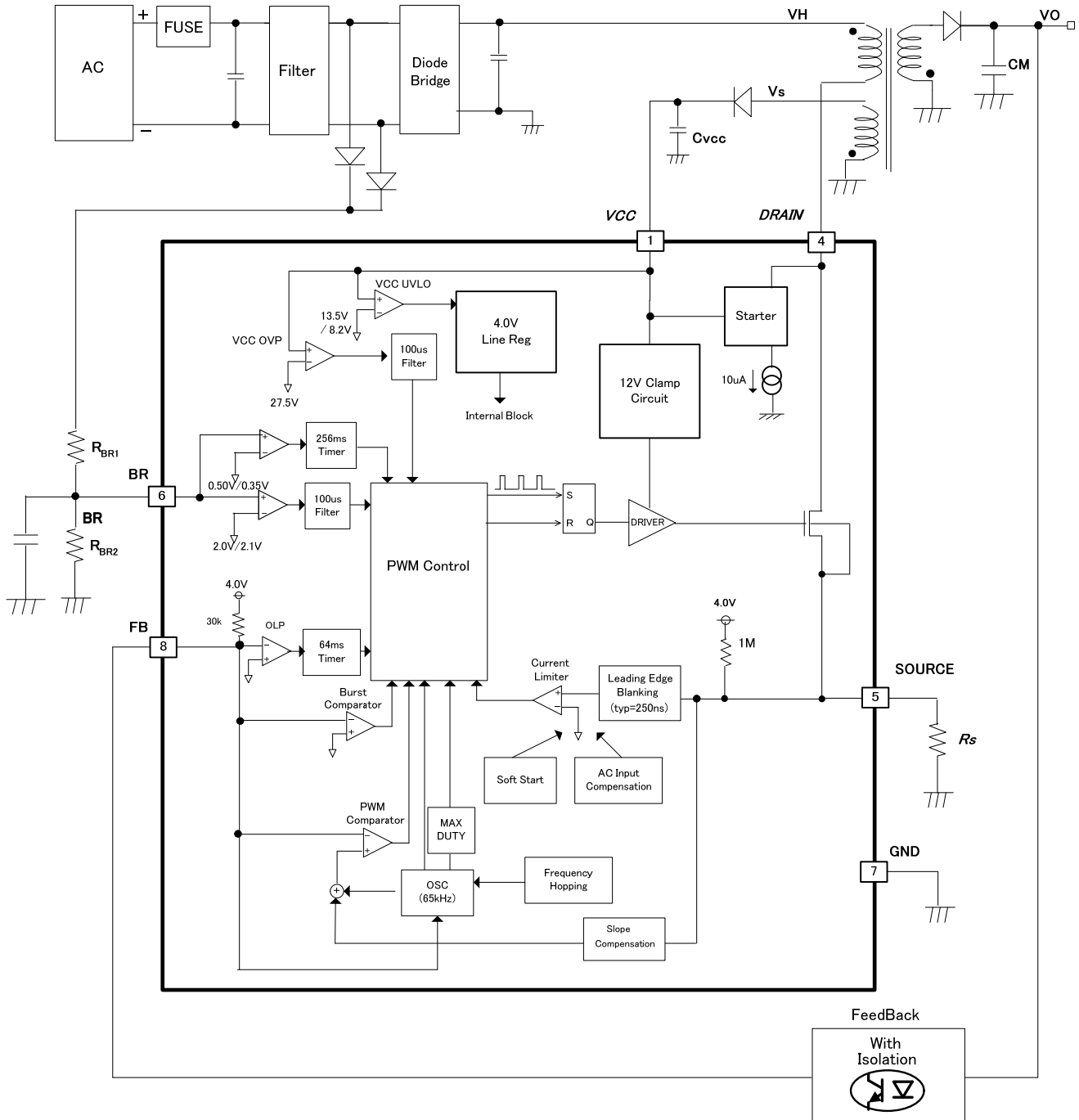

Figure 3. Block Diagram

•Description of Blocks

(1) Start circuit (DRIAN: 4pin)

This IC built in Start circuit (tolerates 650V). It enables to be low standby mode electricity and high speed starting. After starting, consumption power is idling current I_{START3} (typ=10uA) only. Reference values of Starting time are shown in Figure 6. When $C_{VCC}=10\mu F$ it can start less than 0.1 sec.

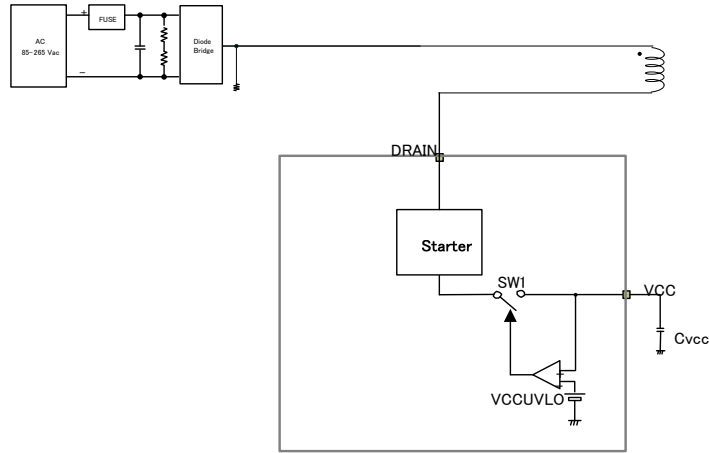

Figure 4. Block diagram of start circuit

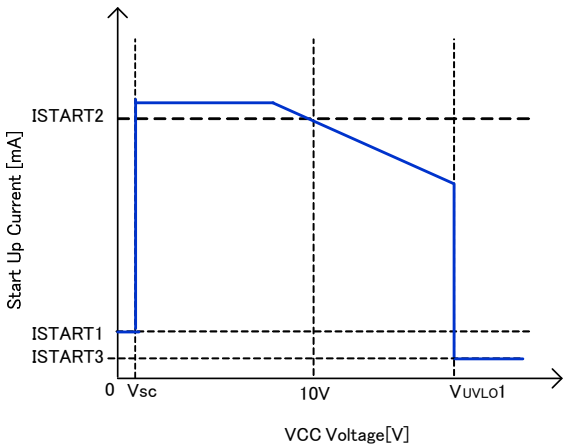

Figure 5. Start current vs VCC voltage

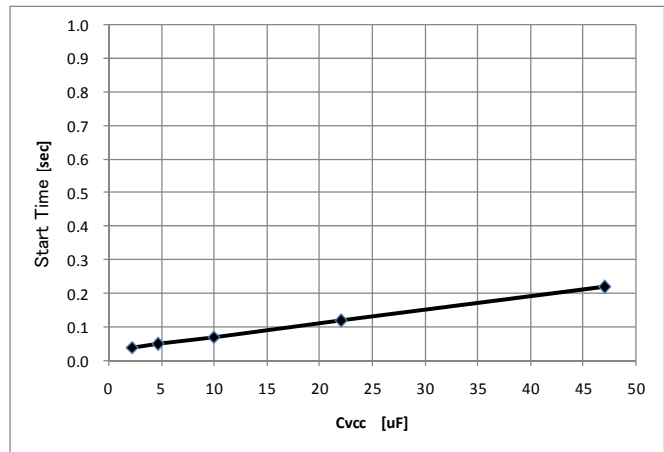

Figure 6. Start time (reference value)

* Start current flows from the DRAIN pin

ex) Consumption power of start circuit only when the Vac=100V
 $P_{VH} = 100V \cdot \sqrt{2} \cdot 10\mu A = 1.41mW$

ex) Consumption power of start circuit only when the Vac=240V
 $P_{VH} = 240V \cdot \sqrt{2} \cdot 10\mu A = 3.38mW$

(2) Start sequences
 (Soft start operation, light load operation, and auto recovery operation during overload protection)

Start sequences are shown in Figure 7. See the sections below for detailed descriptions.

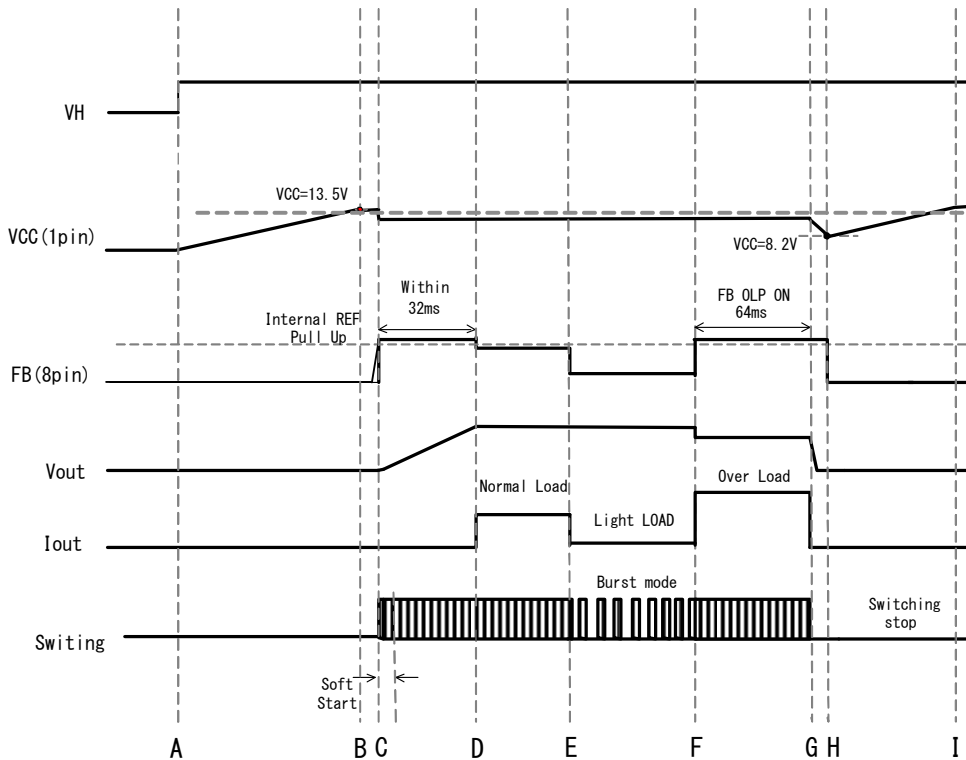

Figure 7. Start sequences Timing Chart

- A: Input voltage V_H is applied
- B: This IC starts operation when VCC pin voltage rises and $V_{CC} > V_{UVLO1}$ (13.5 V typ).
 Switching function starts when other protection functions are judged as normal. Until the secondary output voltage becomes constant level, VCC voltage drops because of the VCC consumption current.
 VCC recharge function start if $V_{CC} < V_{CHG1}$ (8.7V typ)
- C : With the soft start function, over current limit value is restricted to prevent any excessive rise in voltage or current.
- D: When the switching operation starts, V_{OUT} rises.
 The output voltage become to stable state, VCC voltage also become to stable state through auxiliary winding.
 Please set the rated voltage within the T_{FOLP1b} period (32ms typ) from $V_{CC} > V_{UVLO1}$.
- E: During a light load, if it reaches FB voltage $< V_{BST}$ (= 0.4Vtyp), the IC starts burst operation to keep power consumption low.
 During burst operation, it becomes low-power consumption mode.
- F : When the FB Voltage $> V_{FOLP1A}$ (=2.8V typ), it becomes a over load operation.
- G: When FB pin voltage keeps V_{FOLP1A} (= 2.8V typ) at or above T_{FOLP} (64ms typ), the overload protection function is triggered and switching stops 64mS later. If the FB pin voltage becomes $FB < V_{FOLP1B}$ even once, the IC's FB OLP timer is reset.
- H : If the VCC voltage drops to $V_{CC} < V_{UVLO2}$ (7.7Vtyp) or below, restart is executed.
- I: The IC's circuit current is reduced and the VCC pin value rises. (Same as B)

(3) VCC pin protection function

BM2PXX1F built in VCC low voltage protection function VCCUVLO (Under Voltage Lock Out), over voltage protection function VCC OVP (Over Voltage Protection) and VCC charge function that operates in case of dropping the VCC voltage. VCC UVLO and VCC OVP monitor VCC pin and prevent VCC pin from destroying switching MOSFET at abnormal voltage.

VCC charge function stabilizes the secondary output voltage by charging from the high voltage line by start circuit at dropping the VCC voltage.

(3-1) VCC UVLO / VCC OVP function

VCCUVLO is auto recovery protection. VCCOVP is latch protection. Refer to the operation figure-8. VCCOVP built in mask time TLATCH (typ=100us). By this function, this IC masks pin generated surge etc. This function operates detection in case of continuing VCC pin voltage > VOVP (typ=27.5V).

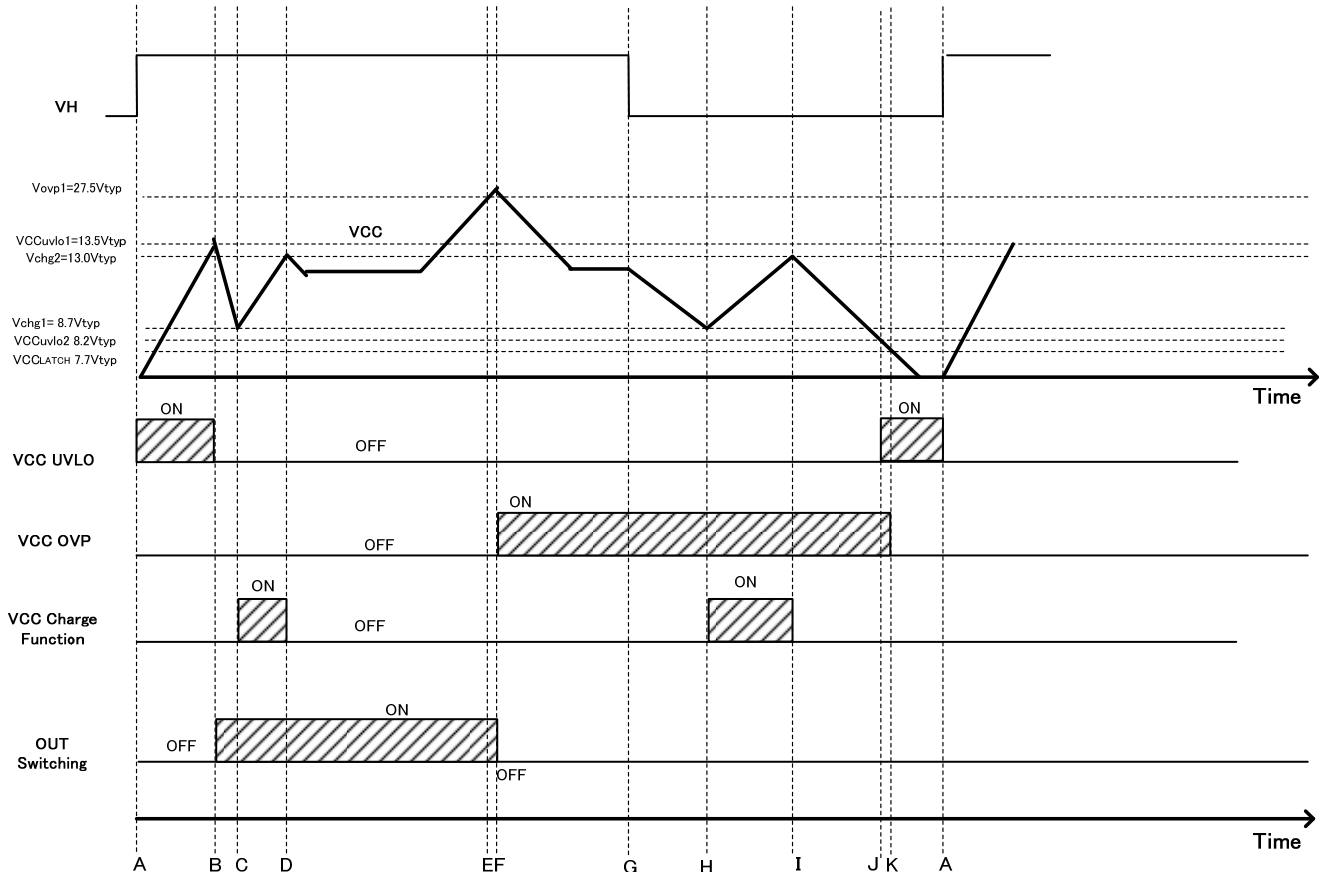

Figure 8. VCC UVLO / OVP Timing Chart

- A: DRAIN voltage input, VCC pin voltage starts rising.
- B: $V_{CC} > V_{uvlo1}$, DC/DC operation starts
- C: $V_{CC} < V_{chg1}$, VCC charge function operates and the VCC voltage is rises.
- D: $V_{CC} > V_{chg2}$, VCC charge function is stopped.
- E: $V_{CC} > V_{ovp1}$, function is detected
- F: $V_{CC} < V_{ovp1}$, continues T_{LATCH} (typ =100us), switching is stopped by the VCCOVP function.
- G: VH is OPEN.VCC Voltage is fall.
- H: Same as C.
- I: Same as D.
- J: $V_{CC} < V_{uvlo2}$, Switching is stopped by the VCC UVLO function
- K: $V_{CC} < V_{latch}$, released from latch

(3-2) VCC Charge function

After VCC charge function operates once the VCC pin $>V_{UVLO1}$ and the DC/DC operation starts then the VCC pin voltage drops to $<V_{CHG1}$. At that time the VCC pin is charged from DRAIN pin through start circuit.

By this operation, BM2PXX1F doesn't occur to start failure.

When VCC pin voltage rises to $VCC >V_{CHG2}$, charge is stopped. The operations are shown in figure 9.

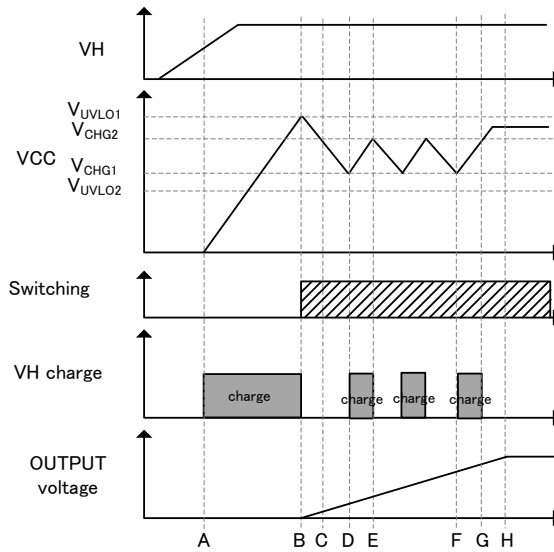

Figure 9. Charge operation VCC pin charge operation

A: DRAIN pin voltage rises, charge starts to VCC pin by the VCC charge function.

B: $VCC > V_{UVLO1}$, VCC UVLO function releases, VCC charge function stops, DC/DC operation starts.

C: When DC/DC operation starts, the VCC voltage drops.

D: $VCC < V_{CHG1}$, VCC recharge function operates and VCC pin voltage rises.

E: $VCC > V_{CHG2}$, VCC recharge function stops.

F: $VCC < V_{CHG1}$, VCC recharge function operates and VCC pin voltage rises.

G: $VCC > V_{CHG1}$, VCC recharge function stops.

H: After start of output voltage finished, VCC is charged by the auxiliary winding VCC pin stabilizes.

(4) DCDC driver (PWM comparator, frequency hopping, slope compensation, OSC, burst)

BM2PXX1F is current mode PWM control.

An internal oscillator sets a fixed switching frequency (65 kHz typ).

BM2PXX1F is integrated switching frequency hopping function which changes the switching frequency to fluctuate as shown in Figure 11 below.

The fluctuation cycle is 125 Hz typ.

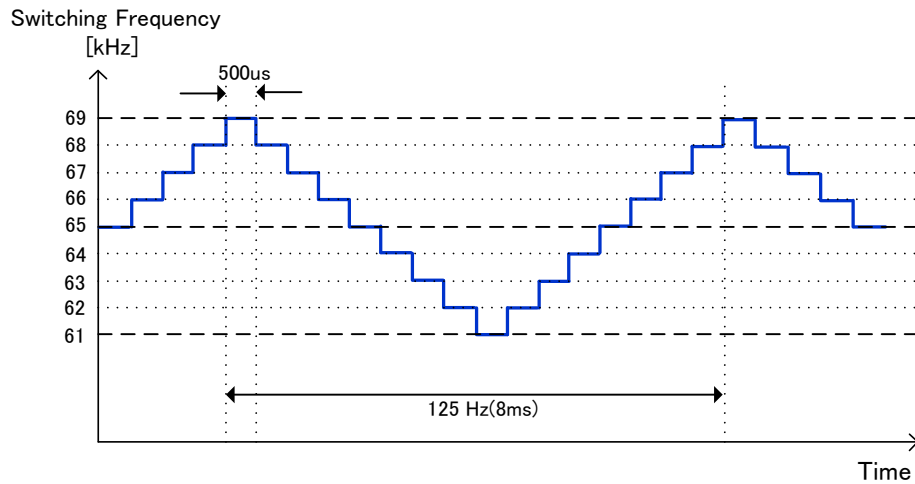

Figure 10. Frequency hopping function

Max duty cycle is fixed as 75% (typ) and MIN pulse width is fixed as 400 ns (typ).

With current mode control, when the duty cycle exceeds 50% sub harmonic oscillation may occur.

As a countermeasure to this, BM2PXX1 is built in slope compensation circuits.

BM2PXX1F is built in burst mode circuit and frequency reduction circuit to achieve lower power consumption, when the load is light.

FB pin is pull up by R_{FB} (30 kΩ typ).

FB pin voltage is changed by secondary output voltage (secondary load power).

FB pin is monitored, burst mode operation and frequency detection start.

Figure 11 shows the FB voltage, and switching frequency, DCDC operation

- mode1 : Burst operation
- mode2: Frequency reduction operation.
- mode3 : Fixed frequency operation.(operate at the max frequency)
- mode4 : Over load operation.(detect the over load state and stop the pulse operation)

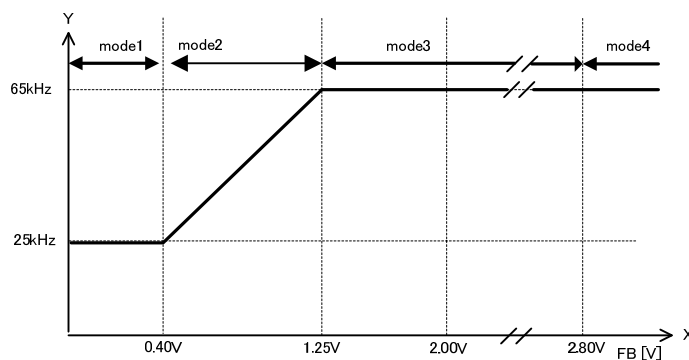

Figure 11. Switching operation state changes by FB pin voltage

(5) Over Current limiter

BM2PXX1F is built in Over Current limiter per cycle. If the SOURCE pin exceeds a certain voltage, switching is stopped. It is also built in AC voltage compensation function. This is the function which compensates the maximum power as the AC voltage's change by increasing over current limiter with time.

Shown in figure-12, 13, and 14.

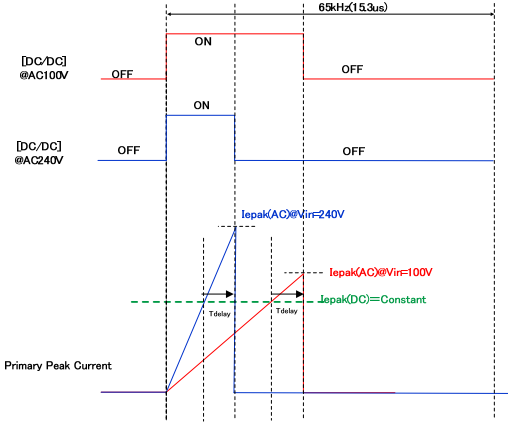

Figure 12. No AC voltage compensation function

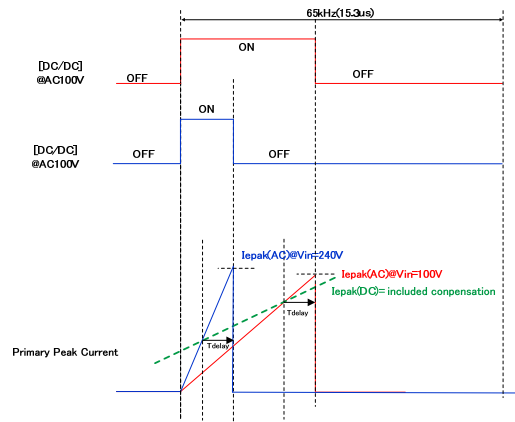

Figure13. Built-in AC compensation voltage

Primary peak current is decided as the formula below.

$$\text{Primary peak current: } I_{\text{peak}} = V_s / R_s + V_{dc} / L_p * T_{\text{delay}}$$

V_s : Over current limiter voltage internal IC, R_s : Current detection resistance, V_{dc} input DC voltage, L_p : Primary inductance, T_{delay} : delay time after detection of over current limiter

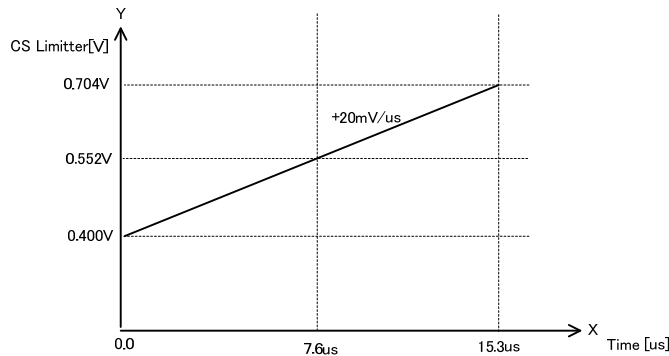

Figure 14. Over current limiter voltage

(6) L.E.B period

When the driver MOSFET is turned ON, surge current occurs at each capacitor component and drive current. Therefore, because SOURCE pin voltage rises temporarily, the detection errors may occur in the over current limiter circuit. To prevent detection errors, DRAIN is switched from high to low and the SOURCE signal is masked for 250 ns by the on-chip LEB (Leading Edge Blanking) function.

(7) SOURCE pin (5pin) short protection function

When the SOURCE pin (1pin) is shorted, BM2PXX1 is over heat.
 BM2PXX1 built in short protection function to prevent destroying.

(8) SOURCE pin (5pin) open protection

If the SOURCE pin becomes OPEN, BM2PXX1 may be damaged.
 To prevent to be damaged, BM2PXX1 built in OPEN protection circuit (auto recovery protection) .

(9) Output over load protection function (FB OLP Comparator)

The output overload protection function monitors the secondary output load status at the FB pin, and stops switching when an overload occurs. In case of overload, the output voltage is reduced and current no longer flows to the photo coupler, so the FB pin voltage rises.

When the FB pin voltage > V_{FOLP1A} (2.8 V typ) continuously for the period T_{FOLP1} (64ms typ), it is judged as an overload and stops switching.

When the FB pin > V_{FOLP1A} (2.8 V typ), if the voltage goes lower than V_{FOLP1B} (2.6V typ) during the period T_{FOLP1} (64ms typ), the overload protection timer is reset. The switching operation is performed during this period T_{FOLP1} (64ms typ).

At startup, the FB voltage is pulled up to the IC's internal voltage, so operation starts at a voltage of V_{FOLP1A} (2.8 V typ) or above. Therefore, at startup the FB voltage must be set to go to V_{FOLP1B} (2.6 Vtyp) or below during the period T_{FOLP1} (64ms typ), and the secondary output voltage's start time must be set within the period T_{FOLP1} (64ms typ) following startup of the IC. Recovery from the once detection of FBOLP, after the period T_{FOLP2} (512 ms typ)

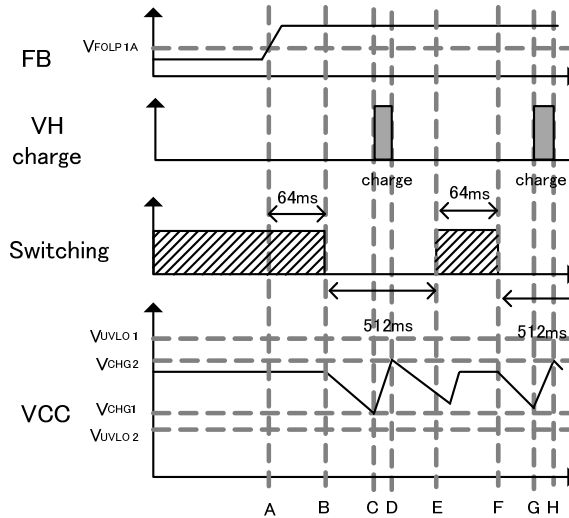

Figure 15. Over load protection (Auto recovery)

- A: The FBOLP comparator detects over load for $FB > V_{FOLP1A}$
- B: If the State of A continues for the period T_{FOLP1} (64ms typ), it is judged as an overload and stops switching after 64ms.
- C: While switching stops for the over load protection function, the VCC pin voltage drops and VCC pin voltage reaches < V_{CHG1} , the VCC charge function operates so the VCC pin voltage rises.
- D: VCC charge function stops when VCC pin voltage > V_{CHG2}
- E: If T_{FOLP2} (typ =512ms) go on from B point, Switching function starts on soft start.
- F: If T_{FOLP1} (64ms typ) go on from E point to continues an overload condition ($FB > V_{FOLP1A}$). Switching function stops at F point.
- G: While switching stops VCC pin voltage drops to < V_{CHG1} , VCC charge function operates and VCC pin voltage rises.
- H: If VCC pin (1pin) voltage becomes over V_{CHG2} by the VCC charge function, VCC charge function operation stops.

(10) Input voltage protection function

This IC has BR-UVLO function and BR-OVP function to monitor input voltage. By monitoring input voltage, it can be prevented from breaking of IC. AC voltage and DC voltage can be monitored by BR pin.

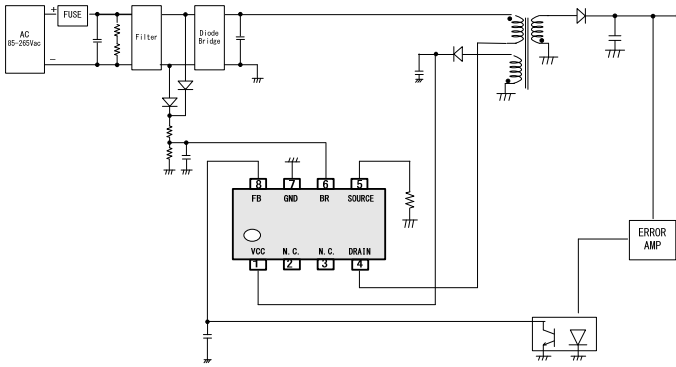

Figure 16(a). AC voltage monitor setting

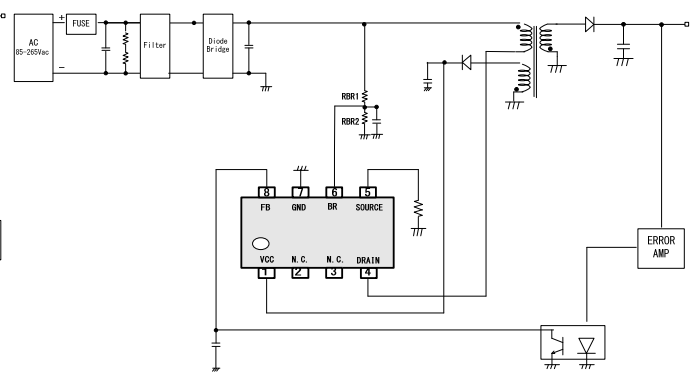

Figure 16(b). DC voltage monitors setting

BRUVLO function can protect the breaking of IC when input voltage is low.

●Operation mode of protection circuit

Operation mode of protection functions are shown in Table 2.

Table 2. Operation mode of protection circuit

Function	Operation mode
VCC Under Voltage Locked Out	Auto recovery
VCC Over Voltage Protection	Latch (with 100us timer)
TSD	Latch (with 100us timer)
FB Over Limited Protection	Auto recovery (with 64ms timer)
SOURCE Open Protection	Auto recovery
BR UVLO	Auto recovery (with 256ms)
BR OVP	Auto recovery (with 100us timer)

●Sequence

The sequence diagram is show in figure-17.
All condition transits OFF Mode $VCC < 8.2V$

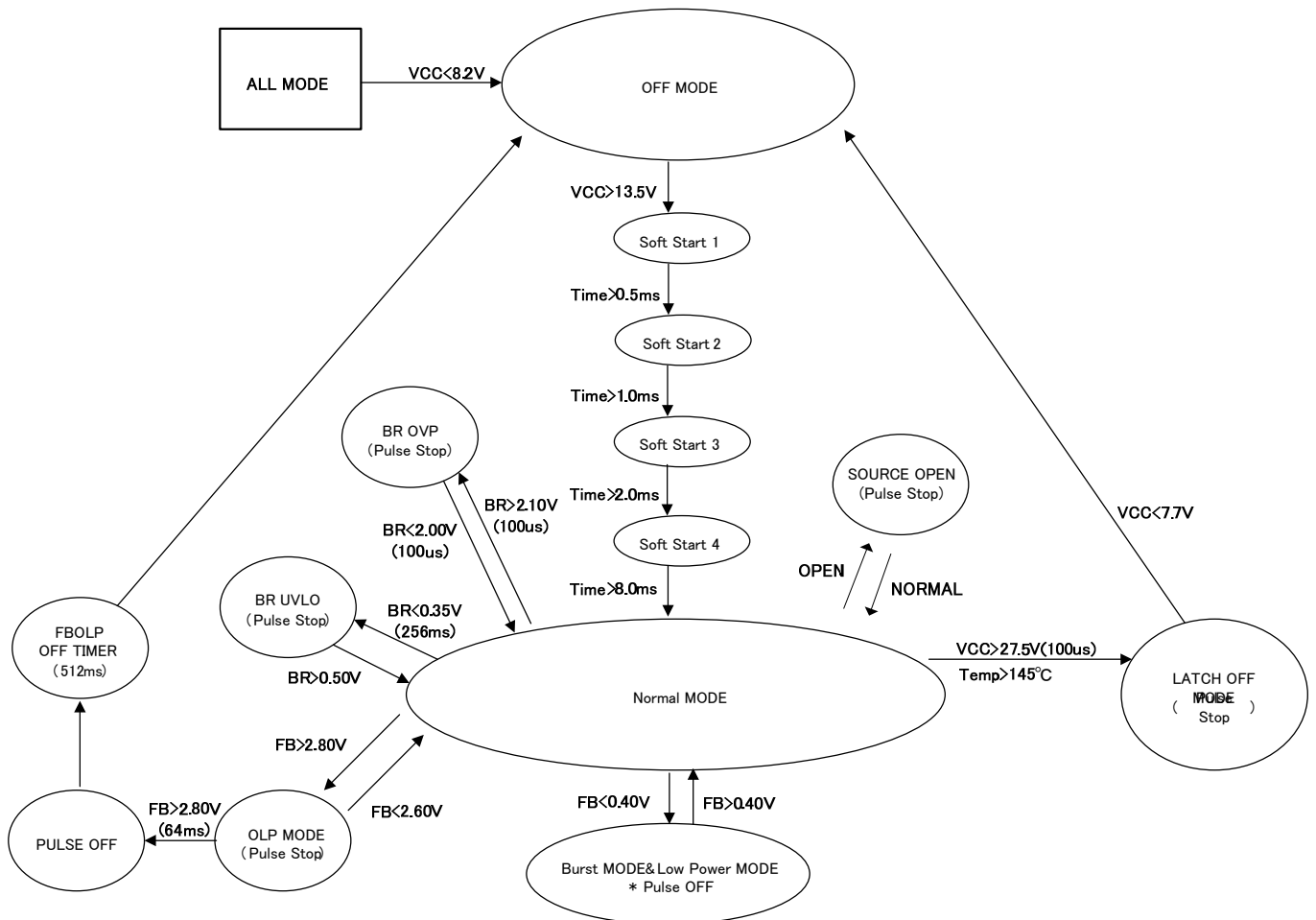

Figure 17. The sequence diagram

• **Thermal loss**

The thermal design should set operation for the following conditions.
 (Since the temperature shown below is the guaranteed temperature, be sure to take a margin into account.)

1. The ambient temperature T_a must be 105°C or less.
2. The IC's loss must be within the allowable dissipation P_d .

The thermal abatement characteristics are as follows.
 (PCB: 70 mm × 70mm × 1.6 mm, mounted on glass epoxy substrate)

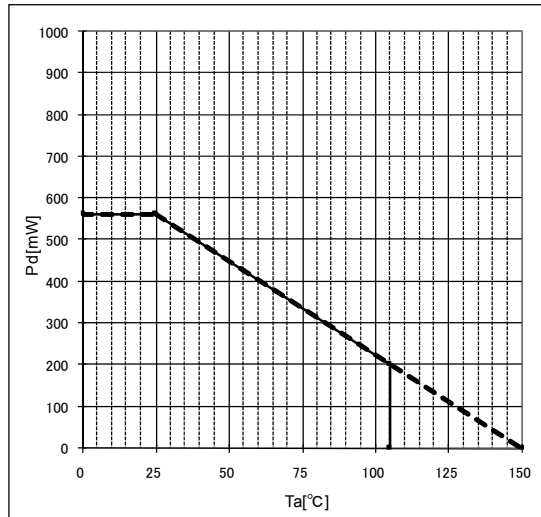
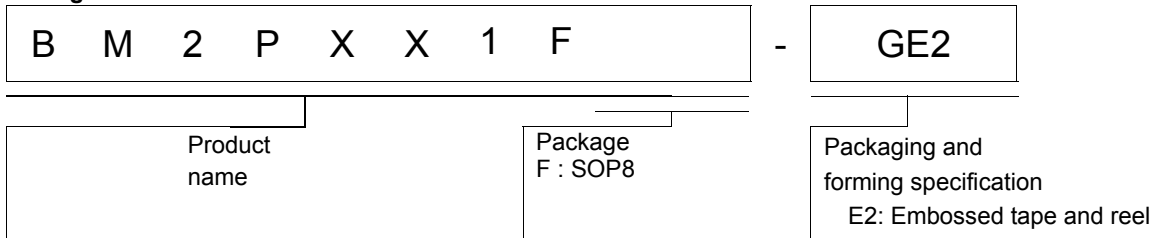
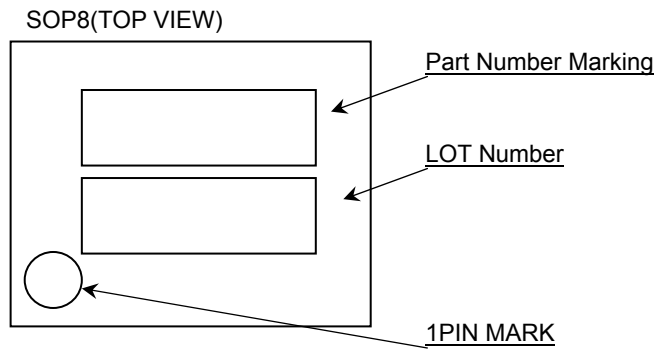

Figure 18. SOP8 Thermal Abatement Characteristics

● Ordering Information



● Marking Diagram



Series	Part Number
BM2P051F	2P051
BM2P091F	2P091

Physical Dimension, Tape and Reel Information

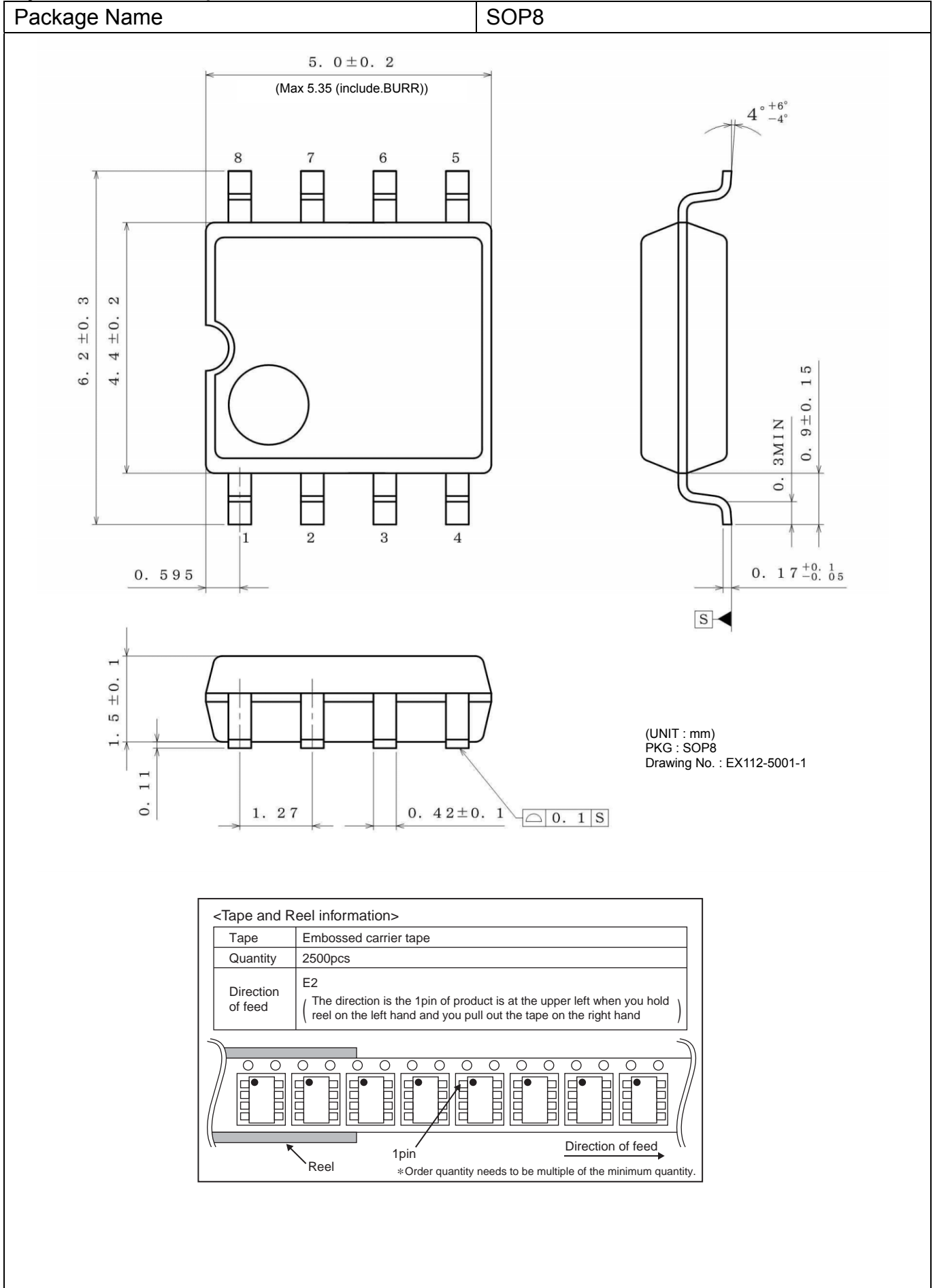

Operational Notes

1. Reverse Connection of Power Supply

Connecting the power supply in reverse polarity can damage the IC. Take precautions against reverse polarity when connecting the power supply, such as mounting an external diode between the power supply and the IC's power supply pins.

2. Power Supply Lines

Design the PCB layout pattern to provide low impedance supply lines. Separate the ground and supply lines of the digital and analog blocks to prevent noise in the ground and supply lines of the digital block from affecting the analog block. Furthermore, connect a capacitor to ground at all power supply pins. Consider the effect of temperature and aging on the capacitance value when using electrolytic capacitors.

3. Ground Voltage

Ensure that no pins are at a voltage below that of the ground pin at any time, even during transient condition.

4. Ground Wiring Pattern

When using both small-signal and large-current ground traces, the two ground traces should be routed separately but connected to a single ground at the reference point of the application board to avoid fluctuations in the small-signal ground caused by large currents. Also ensure that the ground traces of external components do not cause variations on the ground voltage. The ground lines must be as short and thick as possible to reduce line impedance.

5. Thermal Consideration

Should by any chance the power dissipation rating be exceeded the rise in temperature of the chip may result in deterioration of the properties of the chip. The absolute maximum rating of the Pd stated in this specification is when the IC is mounted on a 70mm x 70mm x 1.6mm glass epoxy board. In case of exceeding this absolute maximum rating, increase the board size and copper area to prevent exceeding the Pd rating.

6. Recommended Operating Conditions

These conditions represent a range within which the expected characteristics of the IC can be approximately obtained. The electrical characteristics are guaranteed under the conditions of each parameter.

7. Inrush Current

When power is first supplied to the IC, it is possible that the internal logic may be unstable and inrush current may flow instantaneously due to the internal powering sequence and delays, especially if the IC has more than one power supply. Therefore, give special consideration to power coupling capacitance, power wiring, width of ground wiring, and routing of connections.

8. Operation Under Strong Electromagnetic Field

Operating the IC in the presence of a strong electromagnetic field may cause the IC to malfunction.

9. Testing on Application Boards

When testing the IC on an application board, connecting a capacitor directly to a low-impedance output pin may subject the IC to stress. Always discharge capacitors completely after each process or step. The IC's power supply should always be turned off completely before connecting or removing it from the test setup during the inspection process. To prevent damage from static discharge, ground the IC during assembly and use similar precautions during transport and storage.

10. Inter-pin Short and Mounting Errors

Ensure that the direction and position are correct when mounting the IC on the PCB. Incorrect mounting may result in damaging the IC. Avoid nearby pins being shorted to each other especially to ground, power supply and output pin. Inter-pin shorts could be due to many reasons such as metal particles, water droplets (in very humid environment) and unintentional solder bridge deposited in between pins during assembly to name a few.

Operational Notes – continued

11. Unused Input Pins

Input pins of an IC are often connected to the gate of a MOS transistor. The gate has extremely high impedance and extremely low capacitance. If left unconnected, the electric field from the outside can easily charge it. The small charge acquired in this way is enough to produce a significant effect on the conduction through the transistor and cause unexpected operation of the IC. So unless otherwise specified, unused input pins should be connected to the power supply or ground line.

12. Regarding the Input Pin of the IC

This monolithic IC contains P+ isolation and P substrate layers between adjacent elements in order to keep them isolated. P-N junctions are formed at the intersection of the P layers with the N layers of other elements, creating a parasitic diode or transistor. For example (refer to figure below):

When $GND > Pin A$ and $GND > Pin B$, the P-N junction operates as a parasitic diode.
When $GND > Pin B$, the P-N junction operates as a parasitic transistor.

Parasitic diodes inevitably occur in the structure of the IC. The operation of parasitic diodes can result in mutual interference among circuits, operational faults, or physical damage. Therefore, conditions that cause these diodes to operate, such as applying a voltage lower than the GND voltage to an input pin (and thus to the P substrate) should be avoided.

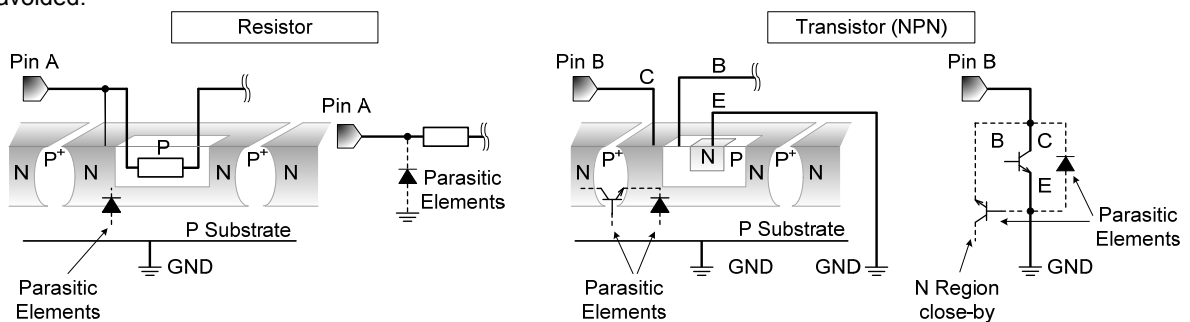

Figure 19. Example of monolithic IC structure

13. Ceramic Capacitor

When using a ceramic capacitor, determine the dielectric constant considering the change of capacitance with temperature and the decrease in nominal capacitance due to DC bias and others.

14. Area of Safe Operation (ASO)

Operate the IC such that the output voltage, output current, and power dissipation are all within the Area of Safe Operation (ASO).

15. Thermal Shutdown Circuit(TSD)

This IC has a built-in thermal shutdown circuit that prevents heat damage to the IC. Normal operation should always be within the IC's power dissipation rating. If however the rating is exceeded for a continued period, the junction temperature (T_j) will rise which will activate the TSD circuit that will turn OFF all output pins. The IC should be powered down and turned ON again to resume normal operation because the TSD circuit keeps the outputs at the OFF state even if the T_j falls below the TSD threshold.

Note that the TSD circuit operates in a situation that exceeds the absolute maximum ratings and therefore, under no circumstances, should the TSD circuit be used in a set design or for any purpose other than protecting the IC from heat damage.

16. Over Current Protection Circuit (OCP)

This IC incorporates an integrated overcurrent protection circuit that is activated when the load is shorted. This protection circuit is effective in preventing damage due to sudden and unexpected incidents. However, the IC should not be used in applications characterized by continuous operation or transitioning of the protection circuit.

date	Rev. No.	Revision Point
2012.07.19	001	New Release
2013.11.18	003	P7 An explanation for Figure7 P8 An explanation for VCC_UVLO/VCC_OVP function An explanation for Figure8 P11 An explanation for Over Current limiter P12 An explanation for Output over load protection function An explanation for Figure15
2015.02.23	004	P1 Package size P17 Physical Dimension
2015.05.15	005	P14 Operation mode of protection circuit P14 Sequence
2015.09.24	006	P3 A value of BR UVLO detection voltage 1 P7 An explanation of Start sequence P8 An explanation of VCC pin protection function P8 An explanation of VCC UVLO / VCC OVP function P9 An explanation of VCC Charge function P11 An explanation of Over Current Limiter P12 An explanation of Output over load protection function

Notice

Precaution on using ROHM Products

- Our Products are designed and manufactured for application in ordinary electronic equipments (such as AV equipment, OA equipment, telecommunication equipment, home electronic appliances, amusement equipment, etc.). If you intend to use our Products in devices requiring extremely high reliability (such as medical equipment ^(Note 1), transport equipment, traffic equipment, aircraft/spacecraft, nuclear power controllers, fuel controllers, car equipment including car accessories, safety devices, etc.) and whose malfunction or failure may cause loss of human life, bodily injury or serious damage to property ("Specific Applications"), please consult with the ROHM sales representative in advance. Unless otherwise agreed in writing by ROHM in advance, ROHM shall not be in any way responsible or liable for any damages, expenses or losses incurred by you or third parties arising from the use of any ROHM's Products for Specific Applications.

(Note1) Medical Equipment Classification of the Specific Applications

JAPAN	USA	EU	CHINA
CLASS III	CLASS III	CLASS II b	CLASS III
CLASS IV		CLASS III	

- ROHM designs and manufactures its Products subject to strict quality control system. However, semiconductor products can fail or malfunction at a certain rate. Please be sure to implement, at your own responsibilities, adequate safety measures including but not limited to fail-safe design against the physical injury, damage to any property, which a failure or malfunction of our Products may cause. The following are examples of safety measures:
 - Installation of protection circuits or other protective devices to improve system safety
 - Installation of redundant circuits to reduce the impact of single or multiple circuit failure
- Our Products are designed and manufactured for use under standard conditions and not under any special or extraordinary environments or conditions, as exemplified below. Accordingly, ROHM shall not be in any way responsible or liable for any damages, expenses or losses arising from the use of any ROHM's Products under any special or extraordinary environments or conditions. If you intend to use our Products under any special or extraordinary environments or conditions (as exemplified below), your independent verification and confirmation of product performance, reliability, etc. prior to use, must be necessary:
 - Use of our Products in any types of liquid, including water, oils, chemicals, and organic solvents
 - Use of our Products outdoors or in places where the Products are exposed to direct sunlight or dust
 - Use of our Products in places where the Products are exposed to sea wind or corrosive gases, including Cl₂, H₂S, NH₃, SO₂, and NO₂
 - Use of our Products in places where the Products are exposed to static electricity or electromagnetic waves
 - Use of our Products in proximity to heat-producing components, plastic cords, or other flammable items
 - Sealing or coating our Products with resin or other coating materials
 - Use of our Products without cleaning residue of flux (even if you use no-clean type fluxes, cleaning residue of flux is recommended); or Washing our Products by using water or water-soluble cleaning agents for cleaning residue after soldering
 - Use of the Products in places subject to dew condensation
- The Products are not subject to radiation-proof design.
- Please verify and confirm characteristics of the final or mounted products in using the Products.
- In particular, if a transient load (a large amount of load applied in a short period of time, such as pulse. is applied, confirmation of performance characteristics after on-board mounting is strongly recommended. Avoid applying power exceeding normal rated power; exceeding the power rating under steady-state loading condition may negatively affect product performance and reliability.
- De-rate Power Dissipation (Pd) depending on Ambient temperature (Ta). When used in sealed area, confirm the actual ambient temperature.
- Confirm that operation temperature is within the specified range described in the product specification.
- ROHM shall not be in any way responsible or liable for failure induced under deviant condition from what is defined in this document.

Precaution for Mounting / Circuit board design

- When a highly active halogenous (chlorine, bromine, etc.) flux is used, the residue of flux may negatively affect product performance and reliability.
- In principle, the reflow soldering method must be used on a surface-mount products, the flow soldering method must be used on a through hole mount products. If the flow soldering method is preferred on a surface-mount products, please consult with the ROHM representative in advance.

For details, please refer to ROHM Mounting specification

Precautions Regarding Application Examples and External Circuits

1. If change is made to the constant of an external circuit, please allow a sufficient margin considering variations of the characteristics of the Products and external components, including transient characteristics, as well as static characteristics.
2. You agree that application notes, reference designs, and associated data and information contained in this document are presented only as guidance for Products use. Therefore, in case you use such information, you are solely responsible for it and you must exercise your own independent verification and judgment in the use of such information contained in this document. ROHM shall not be in any way responsible or liable for any damages, expenses or losses incurred by you or third parties arising from the use of such information.

Precaution for Electrostatic

This Product is electrostatic sensitive product, which may be damaged due to electrostatic discharge. Please take proper caution in your manufacturing process and storage so that voltage exceeding the Products maximum rating will not be applied to Products. Please take special care under dry condition (e.g. Grounding of human body / equipment / solder iron, isolation from charged objects, setting of Ionizer, friction prevention and temperature / humidity control).

Precaution for Storage / Transportation

1. Product performance and soldered connections may deteriorate if the Products are stored in the places where:
 - [a] the Products are exposed to sea winds or corrosive gases, including Cl₂, H₂S, NH₃, SO₂, and NO₂
 - [b] the temperature or humidity exceeds those recommended by ROHM
 - [c] the Products are exposed to direct sunshine or condensation
 - [d] the Products are exposed to high Electrostatic
2. Even under ROHM recommended storage condition, solderability of products out of recommended storage time period may be degraded. It is strongly recommended to confirm solderability before using Products of which storage time is exceeding the recommended storage time period.
3. Store / transport cartons in the correct direction, which is indicated on a carton with a symbol. Otherwise bent leads may occur due to excessive stress applied when dropping of a carton.
4. Use Products within the specified time after opening a humidity barrier bag. Baking is required before using Products of which storage time is exceeding the recommended storage time period.

Precaution for Product Label

QR code printed on ROHM Products label is for ROHM's internal use only.

Precaution for Disposition

When disposing Products please dispose them properly using an authorized industry waste company.

Precaution for Foreign Exchange and Foreign Trade act

Since concerned goods might be fallen under listed items of export control prescribed by Foreign exchange and Foreign trade act, please consult with ROHM in case of export.

Precaution Regarding Intellectual Property Rights

1. All information and data including but not limited to application example contained in this document is for reference only. ROHM does not warrant that foregoing information or data will not infringe any intellectual property rights or any other rights of any third party regarding such information or data.
2. ROHM shall not have any obligations where the claims, actions or demands arising from the combination of the Products with other articles such as components, circuits, systems or external equipment (including software).
3. No license, expressly or implied, is granted hereby under any intellectual property rights or other rights of ROHM or any third parties with respect to the Products or the information contained in this document. Provided, however, that ROHM will not assert its intellectual property rights or other rights against you or your customers to the extent necessary to manufacture or sell products containing the Products, subject to the terms and conditions herein.

Other Precaution

1. This document may not be reprinted or reproduced, in whole or in part, without prior written consent of ROHM.
2. The Products may not be disassembled, converted, modified, reproduced or otherwise changed without prior written consent of ROHM.
3. In no event shall you use in any way whatsoever the Products and the related technical information contained in the Products or this document for any military purposes, including but not limited to, the development of mass-destruction weapons.
4. The proper names of companies or products described in this document are trademarks or registered trademarks of ROHM, its affiliated companies or third parties.

General Precaution

1. Before you use our Products, you are requested to carefully read this document and fully understand its contents. ROHM shall not be in any way responsible or liable for failure, malfunction or accident arising from the use of any ROHM's Products against warning, caution or note contained in this document.
2. All information contained in this document is current as of the issuing date and subject to change without any prior notice. Before purchasing or using ROHM's Products, please confirm the latest information with a ROHM sales representative.
3. The information contained in this document is provided on an "as is" basis and ROHM does not warrant that all information contained in this document is accurate and/or error-free. ROHM shall not be in any way responsible or liable for any damages, expenses or losses incurred by you or third parties resulting from inaccuracy or errors of or concerning such information.

Mouser Electronics

Authorized Distributor

Click to View Pricing, Inventory, Delivery & Lifecycle Information:

[ROHM Semiconductor:](#)

[BM2P091F-GE2](#) [BM2P051F-GE2](#)

Компания «Океан Электроники» предлагает заключение долгосрочных отношений при поставках импортных электронных компонентов на взаимовыгодных условиях!

Наши преимущества:

- Поставка оригинальных импортных электронных компонентов напрямую с производств Америки, Европы и Азии, а так же с крупнейших складов мира;
- Широкая линейка поставок активных и пассивных импортных электронных компонентов (более 30 млн. наименований);
- Поставка сложных, дефицитных, либо снятых с производства позиций;
- Оперативные сроки поставки под заказ (от 5 рабочих дней);
- Экспресс доставка в любую точку России;
- Помощь Конструкторского Отдела и консультации квалифицированных инженеров;
- Техническая поддержка проекта, помощь в подборе аналогов, поставка прототипов;
- Поставка электронных компонентов под контролем ВП;
- Система менеджмента качества сертифицирована по Международному стандарту ISO 9001;
- При необходимости вся продукция военного и аэрокосмического назначения проходит испытания и сертификацию в лаборатории (по согласованию с заказчиком);
- Поставка специализированных компонентов военного и аэрокосмического уровня качества (Xilinx, Altera, Analog Devices, Intersil, Interpoint, Microsemi, Actel, Aeroflex, Peregrine, VPT, Syfer, Eurofarad, Texas Instruments, MS Kennedy, Miteq, Cobham, E2V, MA-COM, Hittite, Mini-Circuits, General Dynamics и др.);

Компания «Океан Электроники» является официальным дистрибьютором и эксклюзивным представителем в России одного из крупнейших производителей разъемов военного и аэрокосмического назначения «JONHON», а так же официальным дистрибьютором и эксклюзивным представителем в России производителя высокотехнологичных и надежных решений для передачи СВЧ сигналов «FORSTAR».



JONHON

«JONHON» (основан в 1970 г.)

Разъемы специального, военного и аэрокосмического назначения:

(Применяются в военной, авиационной, аэрокосмической, морской, железнодорожной, горно- и нефтедобывающей отраслях промышленности)

«FORSTAR» (основан в 1998 г.)

ВЧ соединители, коаксиальные кабели, кабельные сборки и микроволновые компоненты:

(Применяются в телекоммуникациях гражданского и специального назначения, в средствах связи, РЛС, а так же военной, авиационной и аэрокосмической отраслях промышленности).



Телефон: 8 (812) 309-75-97 (многоканальный)

Факс: 8 (812) 320-03-32

Электронная почта: ocean@oceanchips.ru

Web: <http://oceanchips.ru/>

Адрес: 198099, г. Санкт-Петербург, ул. Калинина, д. 2, корп. 4, лит. А