

Interactive Catalog Supplements Catalog PDFs

If you need detailed product information, or help choosing the right product for your application, see our [Interactive Catalog](#). Use the [Interactive Catalog](#) to access the most complete and up-to-date information available.

The [Interactive Catalog](#) provides an extensive collection of product specifications, application data, and technical literature that can be searched based on criteria you select.

This PDF catalog information was published in November 2000.



Sensing and Control
[Interactive
Catalog...](#)

**Click this icon to try
the Interactive Catalog.**

Sensing and Control

Honeywell Inc.

11 West Spring Street

Freeport, IL 61032

Limit and Enclosed Switches

High Capacity Enclosed Switches

BAF1 Series



The elastomer boot on sealed actuator versions protects the actuating mechanism and the internal basic switch from contaminants. There is a seal gasket between the cover plate and the enclosures on all versions.

The cover plate is removed for ease of wiring and switch replacement without demounting the switch.



The actuator position is designated "right" or "left," when looking at the nameplate.

FEATURES

- Up to 20 ampere capacity
- Cast aluminum housing with 3-hole mounting
- Right or left-hand (sealed or unsealed) actuators

- Cover seal, captive cover screws
 - Momentary or maintained contact
 - UL Recognized, file #E12252
 - CSA Certified, file #LR41372
 - Grounding screw
 - NEMA 1, 3*, 4*, and 13*
- (* except BAF1-2RQ9 listings)

ELECTRICAL RATING

Circuitry	Electrical Rating
 <p>Double-pole Double-throw</p>	<p>B</p> <p>UL/CSA Rating: 10 amps, 125 or 250 VAC; 0.3 amp, 125 VDC; 0.15 amp, 250 VDC.</p>
 <p>High Capacity SPDT</p>	<p>D</p> <p>UL/CSA Rating: 20 amps, 125, 250 or 480 VAC; 1 Hp, 125 VAC; 2 Hp, 250 VAC; ½ amp, 125 VDC; ¼ amp, 250 VDC; Lamp Load — 10 amps, 125 VAC.</p>

STRAIGHT PLUNGER ACTUATED SWITCHES



With seal boot, right-hand actuator

ORDER GUIDE

Description	Elec. Rating	Actuator Position†	Catalog Listing	O.P. mm in.	O.F. max. N lbs.	P.T. max. mm in.	O.T. min. mm in.	D.T. max. mm in.
With seal boot.	SPDT	Right	BAF1-2RN-RH	53,19±0,76	11,2	2,39	5,56	0,26
		Left	BAF1-2RN-LH	2.094±.030	2.5	.094	.219	.010
DPDT	B	Right	DTF2-2RN-RH	52,07±1,0	11,2	3,59	3,96	1,53
		Left	DTF2-2RN-LH	2.050±.040	2.5	.141	.156	.060

ROLLER PLUNGER ACTUATED SWITCHES



Without seal boot, right-hand actuator

ORDER GUIDE

Description	Elec. Rating	Actuator Position†	Catalog Listing	O.P. mm in.	O.F. max. N lbs.	P.T. max. mm in.	O.T. min. mm in.	D.T. max. mm in.
Without seal boot.	SPDT	Right	BAF1-2RQ9-RH	64,69	11,1	2,39	3,96	0,25
		Left	BAF1-2RQ9-LH	2.547	2.5	.094	.156	.010
Field adjustable 360° horizontally.	Has O-ring actuator seal SPDT	Right	BAF1-2RQN8-RH	64,69	35,6	3,18	4,75	0,19
		Left	BAF1-2RQN8-LH	2.547	8	.125	.187	.0075

FLEXIBLE ROD ACTUATED SWITCHES



With seal boot, right-hand actuator

ORDER GUIDE

Description	Elec. Rating	Actuator Position†	Catalog Listing	P.T. max.
With seal boot. Operates from any direction, except direct pull. SPDT.	D	Right	BAF1-2RN18-RH	15°
		Left	BAF1-2RN18-LH	

N = Newtons
† When looking at nameplate.

Characteristics: O.F. — Operating Force; P.T. — Pretravel; O.T. — Overtravel; D.T. — Differential Travel; O.P. — Operating Position

For rapid response – off the shelf service, all **bold face** listings are normally stocked items.

High Capacity Enclosed Switches

ROLLER LEVER ACTUATED SWITCHES



With seal boot, right-hand actuator

ORDER GUIDE

Description	Elec. Rating	Actuator Position†	Catalog Listing	O.F. max. N lbs.	P.T. max. mm in.	O.T. min. mm in.	D.T. max. mm in.
With seal boot. Field adjustable 360° horizontally and 225° vertically.	SPDT	Right	BAF1-2RN2-RH	8,90	5,56	6,35	0,51
		Left	BAF1-2RN2-LH	2	.219	.250	.020
	DPDT	Right	DTF2-2RN2-RH	11,1	7,93	5,56	3,05
		Left	DTF2-2RN2-LH	2,5	.312	.219	.120

ONE-WAY ROLLER LEVER ACTUATED SWITCHES



With seal boot right-hand actuator

ORDER GUIDE

Description	Elec. Rating	Actuator Position†	Catalog Listing	O.F. max. N lbs.	P.T. max. mm in.	O.T. min. mm in.	D.T. max. mm in.
With seal boot. Field adjustable 360° horizontally and 180° vertically. SPDT.	D	Right	BAF1-2RN28-RH	8,90	5,56	6,35	0,51
		Left	BAF1-2RN28-LH	2	.219	.250	.020

Limit/Enclosed

MANUALLY ACTUATED SWITCHES



With seal boot, right-hand actuator

ORDER GUIDE

Has 1.5 inch (38,1 mm) diameter button.

Description	Elec. Rating	Actuator Position†	Catalog Listing	O.F. max. N lbs.
With seal boot. Field adjustable 360° horizontally and 180° vertically. SPDT.	D	Right	BAF1-2RN4-RH	8,90
		Left	BAF1-2RN4-LH	2

MAINTAINED CONTACT (RESET) PLUNGER ACTUATED SWITCHES



With seal boots, right-hand actuator

ORDER GUIDE

Contact transfer is maintained after either plunger is operated. (Top plunger provides more accurate and uniform characteristics.)

Description	Elec. Rating	Actuator Position†	Catalog Listing	O.F. max. N lbs.	P.T. max. mm in.	O.T. min. mm in.
With seal boot on both top and bottom (reset) plungers. SPDT.	D	Right	BAF1-3RNX1	7,79 1,75	2,39 .094	4,45 .219

N = Newtons
† When looking at nameplate.

Characteristics: O.F. — Operating Force; P.T. — Pretravel; O.T. — Overtravel; D.T. — Differential Travel

High Capacity Enclosed Switches

REPLACEMENT PARTS

Basic Packets include mounting hardware, an insulator, and a cover seal ring. The plunger seal boot and retaining hardware may be ordered separately as **10PA2**.

CONDUIT SEALING PACKETS

Catalog Listing Packet	Cable O.D. Inches
2PA6	.400"-.435"
2PA16	.435"-.470"
2PA1	.530"-.570"

(See page A41 for description.)

Switch Type	Basic Packet	Catalog Listing Replacement Part Numbers	
		Switching Unit*	Actuator
BAF1-2RN	1PA10	BA-2R708-P7	8PA1**
BAF1-2RQ9	1PA10	BA-2R708-P7	8PA10
BAF1-2RQN8	1PA10	BA-2R708-P7	8PA52
BAF1-2RN18	1PA10	BA-2R708-P7	6PA20**
BAF1-2RN2	1PA10	BA-2R708-P7	6PA2**
BAF1-2RN28	1PA10	BA-2R708-P7	6PA16**
BAF1-2RN4	1PA10	BA-2R708-P7	6PA9**
BAF1-3RNX1	1PA23	BA-3RX717	8PA1**
DTF2-2RN	—	DT-2R-A7	8PA32**
DTF2-2RN2	—	DT-2R-A7	6PA2**

* Includes basic packet.

** Includes seal boot.

MOUNTING DIMENSIONS (For reference only)

PLUNGER (with seal boot)

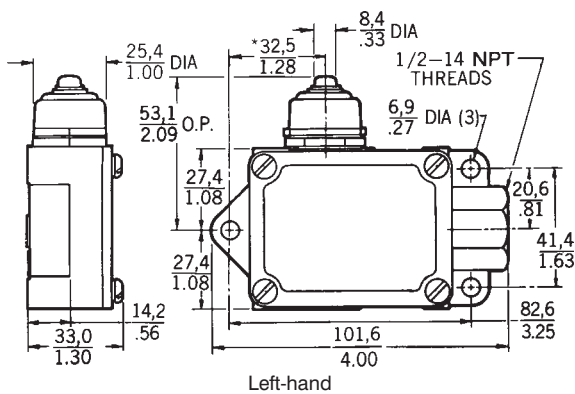

Left-hand

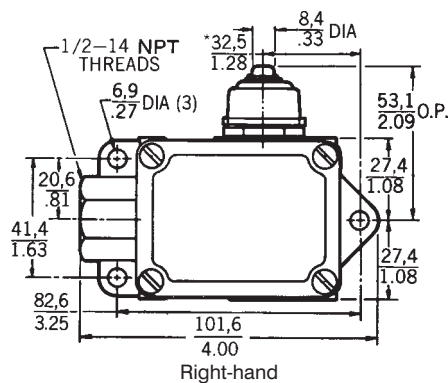

Right-hand

*28.2 on DTF2 Types
1.11

COIL SPRING (with seal boot)

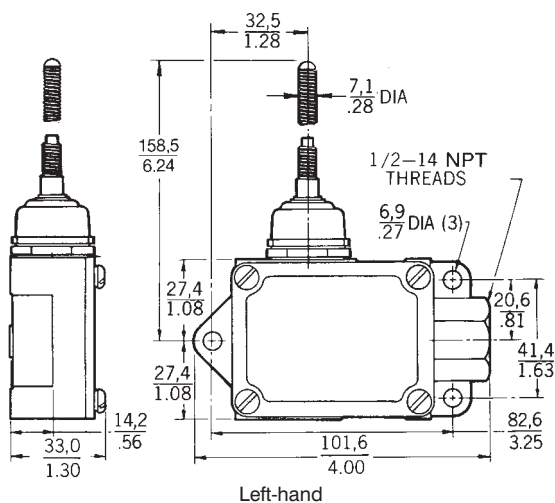

Left-hand

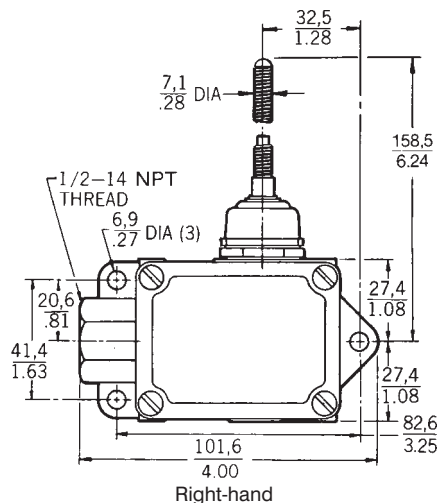

Right-hand

Key: 0,0 = mm
0.00 = inches

Limit and Enclosed Switches

BAF1 Series

High-Capacity Enclosed Switches

MOUNTING DIMENSIONS (For reference only)

ROLLER PLUNGER (without seal boot)

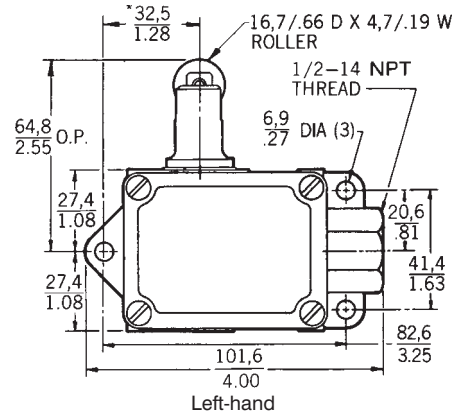
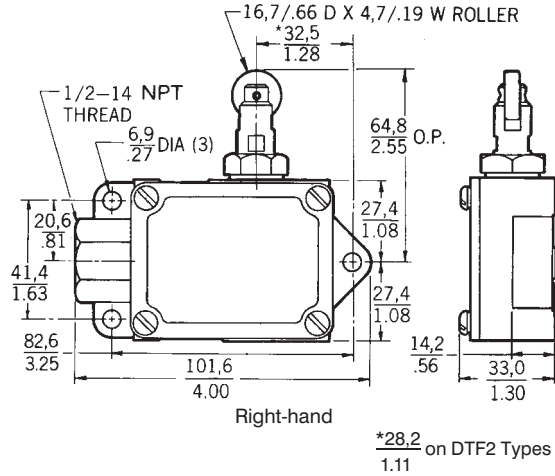

Limit/Enclosed

ROLLER LEVER (with seal boot)

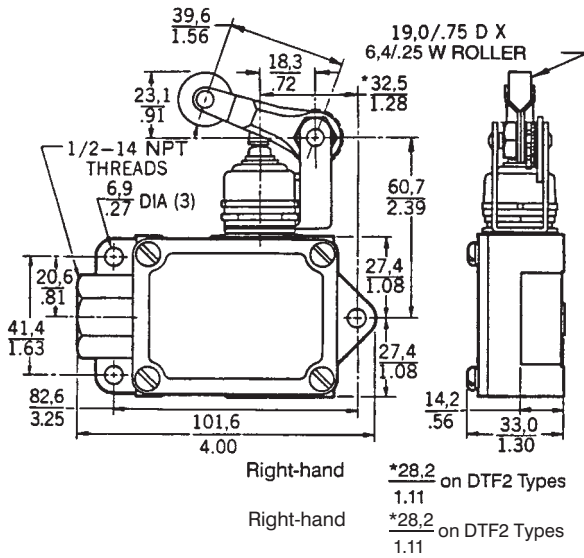

ONE-WAY ROLLER LEVER (with seal boot)

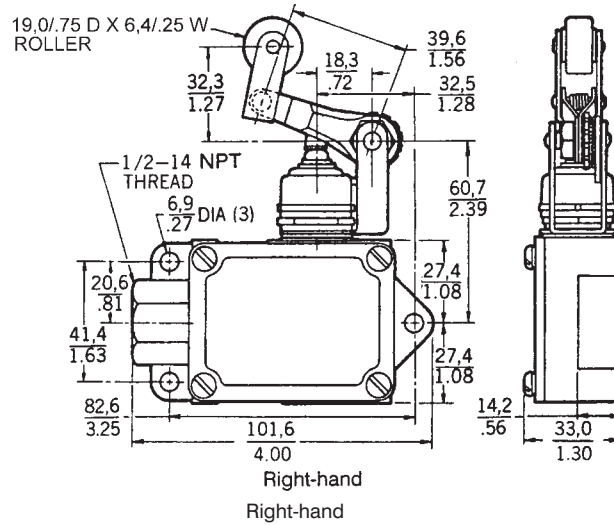

MANUAL (with seal boot)

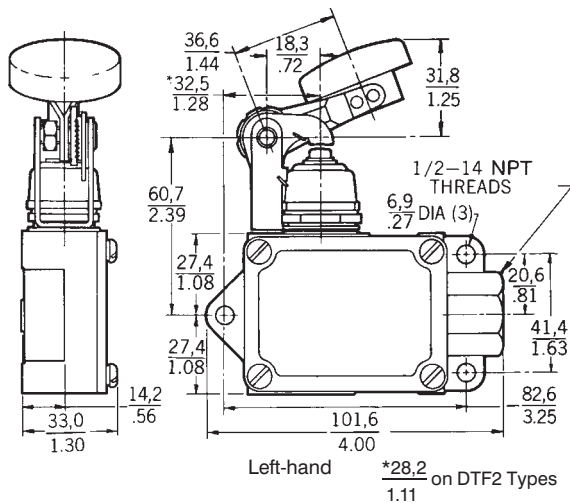

PLUNGER (Reset) (with seal boot)

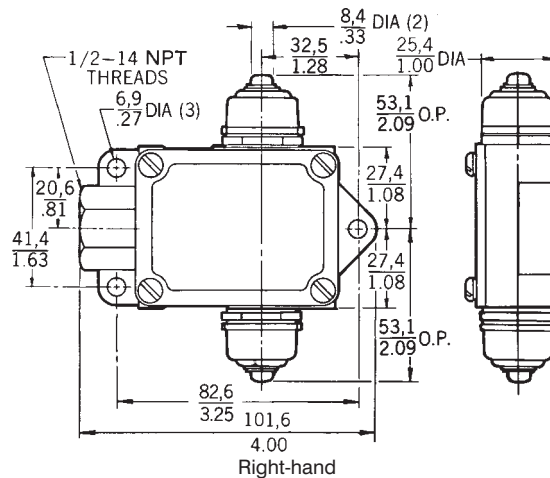

Компания «Океан Электроники» предлагает заключение долгосрочных отношений при поставках импортных электронных компонентов на взаимовыгодных условиях!

Наши преимущества:

- Поставка оригинальных импортных электронных компонентов напрямую с производств Америки, Европы и Азии, а так же с крупнейших складов мира;
- Широкая линейка поставок активных и пассивных импортных электронных компонентов (более 30 млн. наименований);
- Поставка сложных, дефицитных, либо снятых с производства позиций;
- Оперативные сроки поставки под заказ (от 5 рабочих дней);
- Экспресс доставка в любую точку России;
- Помощь Конструкторского Отдела и консультации квалифицированных инженеров;
- Техническая поддержка проекта, помощь в подборе аналогов, поставка прототипов;
- Поставка электронных компонентов под контролем ВП;
- Система менеджмента качества сертифицирована по Международному стандарту ISO 9001;
- При необходимости вся продукция военного и аэрокосмического назначения проходит испытания и сертификацию в лаборатории (по согласованию с заказчиком);
- Поставка специализированных компонентов военного и аэрокосмического уровня качества (Xilinx, Altera, Analog Devices, Intersil, Interpoint, Microsemi, Actel, Aeroflex, Peregrine, VPT, Syfer, Eurofarad, Texas Instruments, MS Kennedy, Miteq, Cobham, E2V, MA-COM, Hittite, Mini-Circuits, General Dynamics и др.);

Компания «Океан Электроники» является официальным дистрибьютором и эксклюзивным представителем в России одного из крупнейших производителей разъемов военного и аэрокосмического назначения «JONHON», а так же официальным дистрибьютором и эксклюзивным представителем в России производителя высокотехнологичных и надежных решений для передачи СВЧ сигналов «FORSTAR».



JONHON

«JONHON» (основан в 1970 г.)

Разъемы специального, военного и аэрокосмического назначения:

(Применяются в военной, авиационной, аэрокосмической, морской, железнодорожной, горно- и нефтедобывающей отраслях промышленности)

«FORSTAR» (основан в 1998 г.)

ВЧ соединители, коаксиальные кабели, кабельные сборки и микроволновые компоненты:

(Применяются в телекоммуникациях гражданского и специального назначения, в средствах связи, РЛС, а так же военной, авиационной и аэрокосмической отраслях промышленности).



Телефон: 8 (812) 309-75-97 (многоканальный)

Факс: 8 (812) 320-03-32

Электронная почта: ocean@oceanchips.ru

Web: <http://oceanchips.ru/>

Адрес: 198099, г. Санкт-Петербург, ул. Калинина, д. 2, корп. 4, лит. А