

PROTECTION PRODUCTS - MicroClamp™

Description

The μ Clamp™ series of TVS arrays are designed to protect sensitive electronics from damage or latch-up due to ESD, lightning, and other voltage-induced transient events. Each device will protect up to four lines operating at **3.3 volts**.

The μ Clamp™3305P is a solid-state device designed specifically for transient suppression. It is constructed using Semtech's proprietary EPD process technology. The EPD process provides low standoff voltages with significant reductions in leakage currents and capacitance over traditional pn junction processes. They offer desirable characteristics for board level protection including fast response time, low clamping voltage and no device degradation.

The μ Clamp3305P may be used to meet the immunity requirements of IEC 61000-4-2, level 4 (± 15 kV air, ± 8 kV contact discharge). It is packaged in an ultra small SLP1616P6 package with a low profile of only 0.58mm. The leads are spaced at a pitch of 0.5mm and are finished with lead-free NiPdAu. The small package makes it ideal for use in portable electronics such as cell phones, digital still cameras, and notebook computers.

Features

- ◆ Transient protection for data lines to **IEC 61000-4-2 (ESD) ± 15 kV (air), ± 8 kV (contact)**
IEC 61000-4-4 (EFT) 40A (tp = 5/50ns)
- ◆ Small package for use in portable electronics
- ◆ Protects five I/O lines
- ◆ Working voltage: 3.3V
- ◆ Low leakage current
- ◆ Low operating and clamping voltages
- ◆ Solid-state silicon-avalanche technology

Mechanical Characteristics

- ◆ SLP1616P6 package
- ◆ RoHS/WEEE Compliant
- ◆ Nominal Dimensions: 1.6 x 1.6 x 0.58 mm
- ◆ Lead Pitch: 0.5mm
- ◆ Lead Finish: NiPdAu
- ◆ Marking : Orientation Mark and Marking Code
- ◆ Packaging : Tape and Reel

Applications

- ◆ Cellular handsets and accessories
- ◆ Notebooks and handhelds
- ◆ MP3 Players
- ◆ Digital cameras
- ◆ Portable instrumentation
- ◆ PDA's

Circuit Diagram

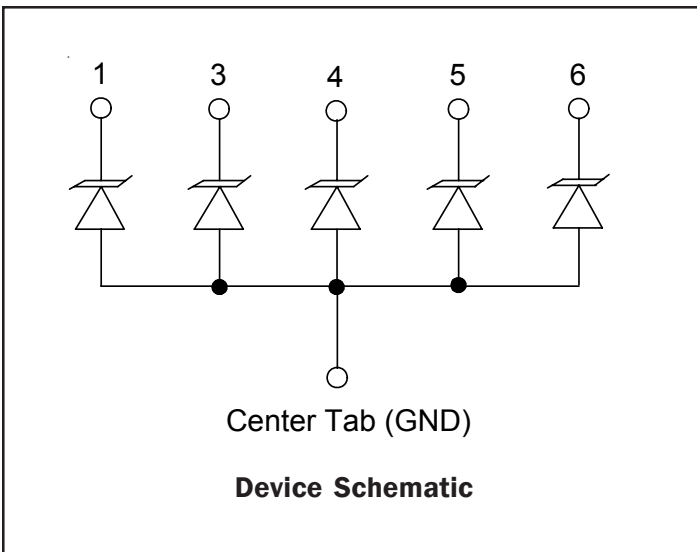

Package

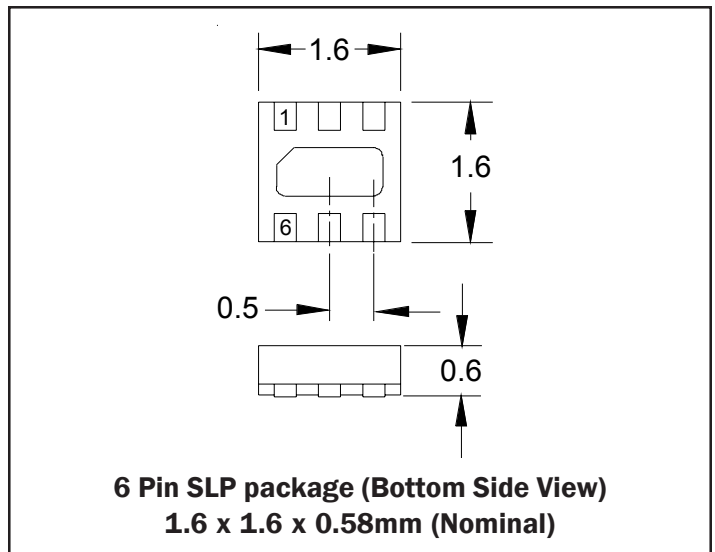

PROTECTION PRODUCTS
Absolute Maximum Rating

| Rating | Symbol | Value | Units |
|--|-----------|------------------|-------|
| Peak Pulse Power (tp = 8/20μs) | P_{pk} | 40 | Watts |
| Maximum Peak Pulse Current (tp = 8/20μs) | I_{pp} | 5 | Amps |
| ESD per IEC 61000-4-2 (Air) ESD per IEC 61000-4-2 (Contact) | V_{pp} | +/- 20 +/- 15 | kV |
| Operating Temperature | T_J | -55 to +125 | °C |
| Storage Temperature | T_{STG} | -55 to +150 | °C |

Electrical Characteristics (T=25°C)

| Parameter | Symbol | Conditions | Minimum | Typical | Maximum | Units |
|---------------------------|-----------|---|---------|---------|---------|-------|
| Reverse Stand-Off Voltage | V_{RWM} | | | | 3.3 | V |
| Punch-Through Voltage | V_{PT} | $I_{PT} = 2\mu A$ | 3.5 | 3.9 | 4.6 | V |
| Snap-Back Voltage | V_{SB} | $I_{SB} = 50mA$ | 2.8 | | | V |
| Reverse Leakage Current | I_R | $V_{RWM} = 3.3V$ | | 0.05 | 0.5 | μA |
| Clamping Voltage | V_C | $I_{pp} = 1A$, tp = 8/20μs Any I/O to Gnd | | | 5.5 | V |
| Clamping Voltage | V_C | $I_{pp} = 5A$, tp = 8/20μs Any I/O to Gnd | | | 8.0 | V |
| Reverse Clamping Voltage | V_{CR} | $I_{pp} = 1A$, tp = 8/20μs Any I/O to Gnd | | | 2.4 | V |
| Junction Capacitance | C_J | I/O pin to Gnd $V_R = 0V$, f = 1MHz | | 20 | 25 | pF |
| | | I/O pin to Gnd $V_R = 3.3V$, f = 1MHz | | 12 | | pF |
| | | I/O pin to I/O pin $V_R = 0V$, f = 1MHz | | 10 | 12.5 | pF |
| | | I/O pin to I/O pin $V_R = 3.3V$, f = 1MHz | | 7.5 | | pF |

PROTECTION PRODUCTS

Typical Characteristics

Non-Repetitive Peak Pulse Power vs. Pulse Time

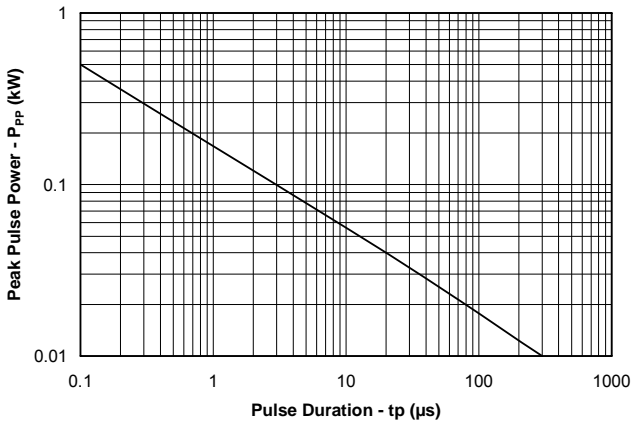

Power Derating Curve

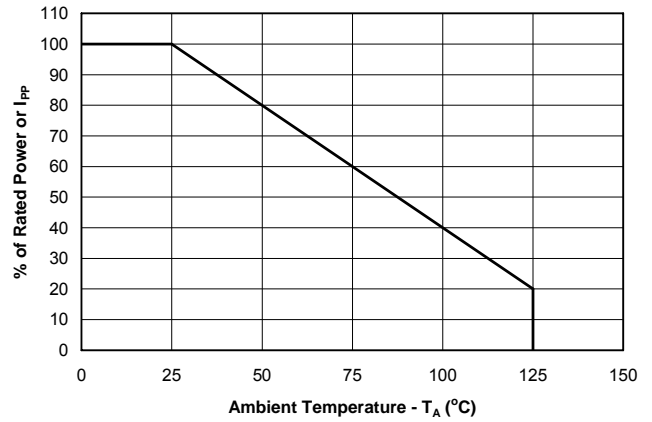

Clamping Voltage vs. Peak Pulse Current

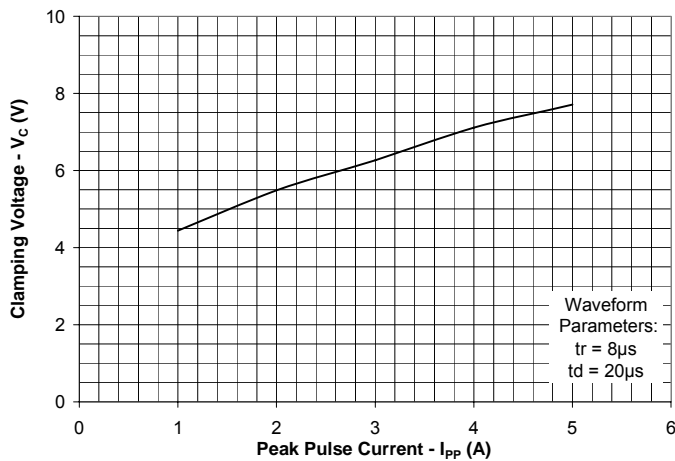

Forward Voltage vs. Forward Current

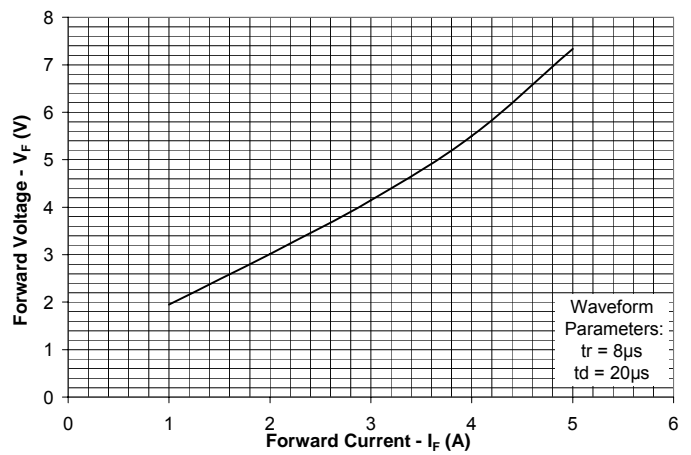

Normalized Capacitance vs. Reverse Voltage

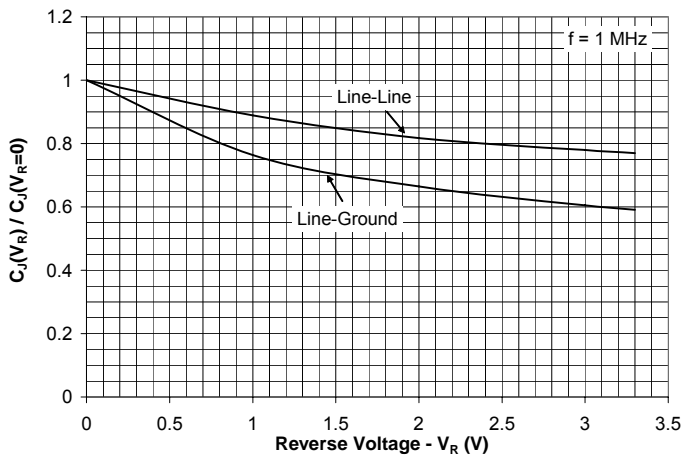

ESD Clamping (8kV Contact per IEC 61000-4-2)

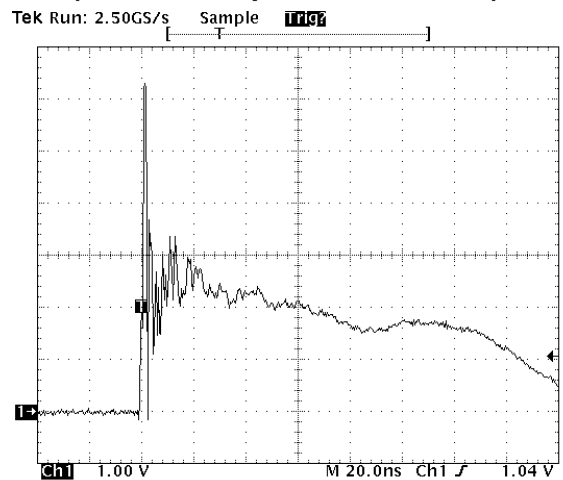

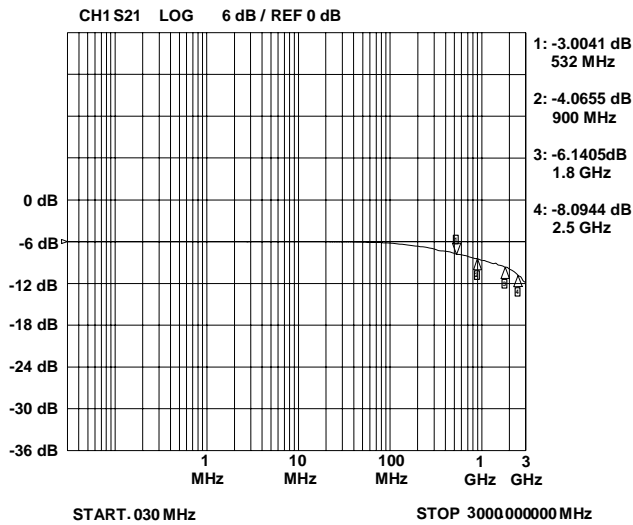
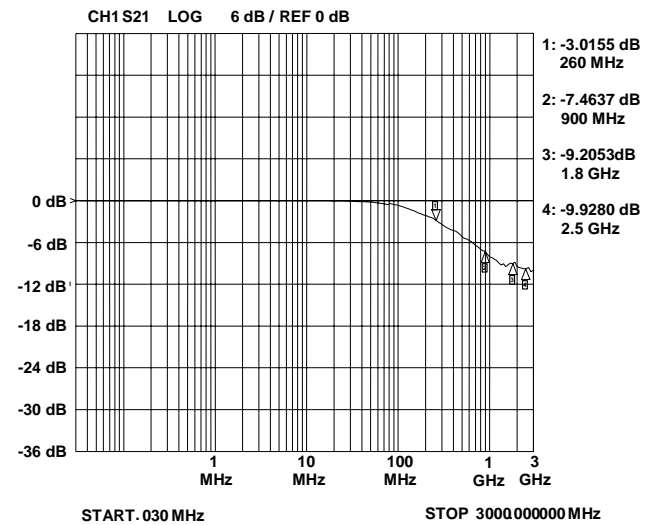
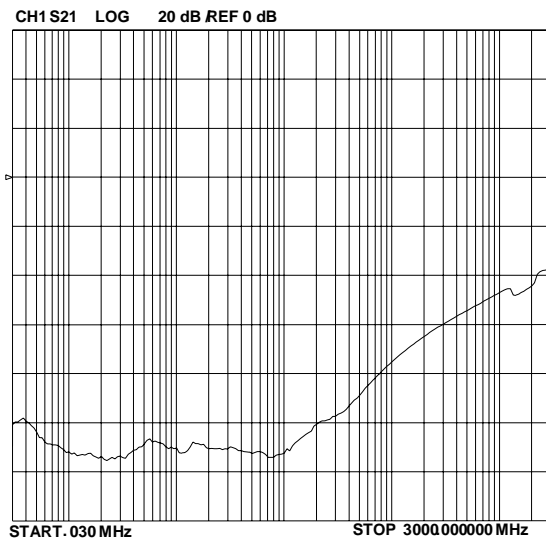
Insertion Loss S21 - LtoL (I/O to I/O)

Insertion Loss S21 -LtoG (I/O to Pin 2)

Crosstalk S21 (I/O to Pin 4)

PROTECTION PRODUCTS

Applications Information

Device Connection Options

The μ Clamp3305P is designed to protect 5 signal lines with an operating voltage of 0 to 3.3V. It will present a high impedance to the protected line up to 3.3 volts. It will “turn on” when the line voltage exceeds 3.5 volts. The device is unidirectional and may be used on lines where the signal polarity is above ground.

Pin 1,3,4,5,6 are connected to I/O signals. The center tab is connected to system ground. Pin 2 should be left open or not connected. All signal lines and ground should be made with the lowest impedance and inductance path as possible. This will improve signal quality of the lines and keep the clamping voltage as low as possible during a fast transient.

Due to the “snap-back” characteristics of the low voltage TVS, it is not recommended that the I/O line be directly connected to a DC source greater than snap-back voltage (V_{SB}) as the device can latch on.

EPD TVS Characteristics

These devices are constructed using Semtech’s proprietary EPD technology. The structure of the EPD TVS is vastly different from the traditional pn-junction devices. At voltages below 5V, high leakage current and junction capacitance render conventional avalanche technology impractical for most applications. However, by utilizing the EPD technology, these devices can effectively operate at 3.3V while maintaining excellent electrical characteristics.

The EPD TVS employs a complex nppn structure in contrast to the pn structure normally found in traditional silicon-avalanche TVS diodes. The EPD mechanism is achieved by engineering the center region of the device such that the reverse biased junction does not avalanche, but will “punch-through” to a conducting state. This structure results in a device with superior DC electrical parameters at low voltages while maintaining the capability to absorb high transient currents.

Figure 1 - Circuit Diagram

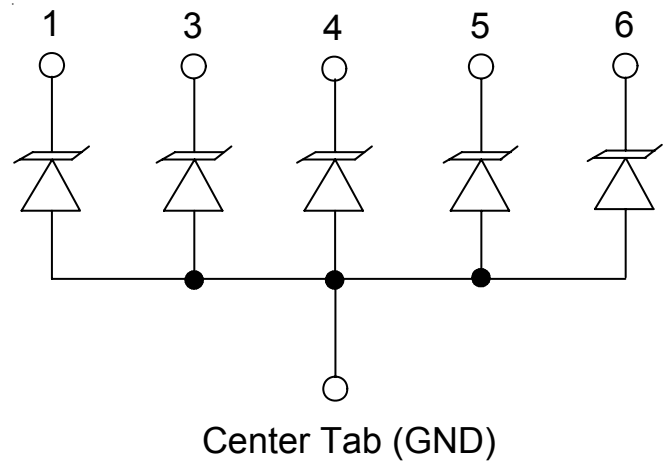

Figure 2 - Layout Example

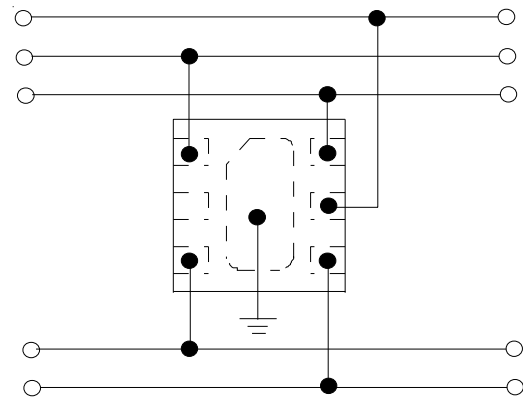
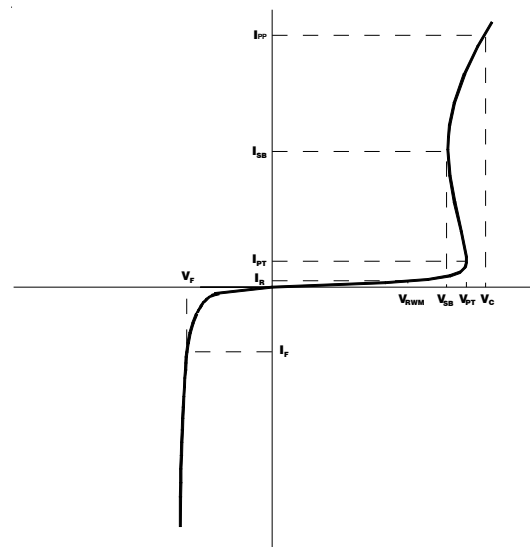
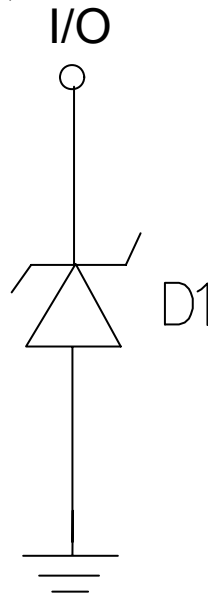

Figure 3 - EPD TVS IV Characteristic Curve

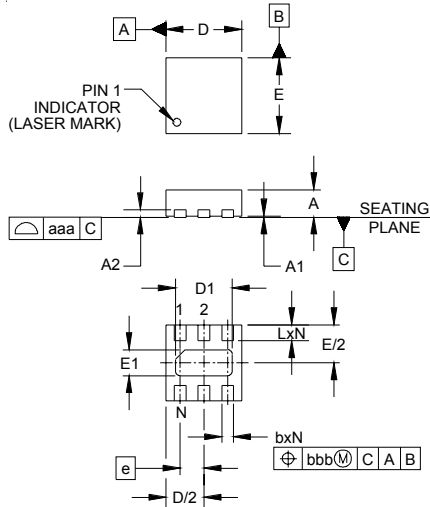



Figure 3 - μ Clamp3305P Spice Model

| μClamp3305P Spice Parameters | | |
|--|-------------|-----------------|
| Parameter | Unit | D1 (TVS) |
| IS | Amp | 2E-12 |
| BV | Volt | 20 |
| VJ | Volt | 0.57 |
| RS | Ohm | 1.444 |
| IBV | Amp | 1.0 E-3 |
| CJO | Farad | 20E-12 |
| TT | sec | 2.541E-9 |
| M | -- | 0.236 |
| N | -- | 1.1 |
| EG | eV | 1.11 |

PROTECTION PRODUCTS

Outline Drawing - SLP1616P6



| DIM | INCHES | | | MILLIMETERS | | |
|-----|----------|--------|----------|-------------|--------|------|
| | MIN | NOM | MAX | MIN | NOM | MAX |
| A | .020 | .023 | .026 | 0.50 | 0.58 | 0.65 |
| A1 | 0.00 | .001 | .002 | 0.00 | 0.03 | 0.05 |
| A2 | | (.005) | | | (0.13) | |
| b | .008 | .010 | .012 | 0.20 | 0.25 | 0.30 |
| D | .059 | .063 | .067 | 1.50 | 1.60 | 1.70 |
| D1 | .041 | .047 | .051 | 1.05 | 1.20 | 1.30 |
| E | .059 | .063 | .067 | 1.50 | 1.60 | 1.70 |
| E1 | .010 | .016 | .020 | 0.25 | 0.40 | 0.50 |
| e | .020 BSC | | 0.50 BSC | | | |
| L | .010 | .013 | .016 | 0.25 | 0.33 | 0.40 |
| N | 6 | | | 6 | | |
| aaa | .003 | | | 0.08 | | |
| bbb | .004 | | | 0.10 | | |

NOTES:

1. CONTROLLING DIMENSIONS ARE IN MILLIMETERS (ANGLES IN DEGREES).
2. COPLANARITY APPLIES TO THE EXPOSED PAD AS WELL AS THE TERMINALS.

Land Pattern - SLP1616P6

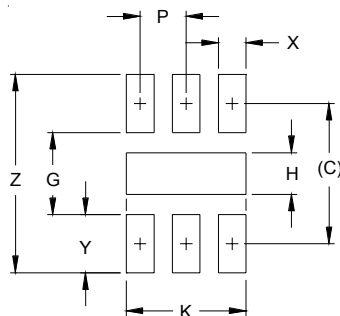

| DIM | DIMENSIONS | |
|-----|------------|-------------|
| | INCHES | MILLIMETERS |
| C | .060 | 1.52 |
| G | .035 | 0.89 |
| H | .018 | 0.45 |
| K | .051 | 1.30 |
| P | .020 | 0.50 |
| X | .012 | 0.30 |
| Y | .025 | 0.63 |
| Z | .085 | 2.15 |

NOTES:

1. CONTROLLING DIMENSIONS ARE IN MILLIMETERS (ANGLES IN DEGREES).
2. THIS LAND PATTERN IS FOR REFERENCE PURPOSES ONLY. CONSULT YOUR MANUFACTURING GROUP TO ENSURE YOUR COMPANY'S MANUFACTURING GUIDELINES ARE MET.
3. THERMAL VIAS IN THE LAND PATTERN OF THE EXPOSED PAD SHALL BE CONNECTED TO A SYSTEM GROUND PLANE. FAILURE TO DO SO MAY COMPROMISE THE THERMAL AND/OR FUNCTIONAL PERFORMANCE OF THE DEVICE.

PROTECTION PRODUCTS

Marking

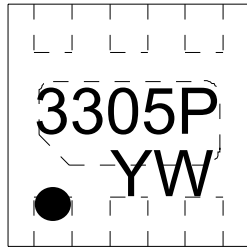

Y = year
W = Week

Ordering Information

| Part Number | Working Voltage | Lead Finish | Qty per Reel | Reel Size |
|-----------------|-----------------|-------------|--------------|-----------|
| uClamp3305P.TCT | 3.3V | Pb Free | 3,000 | 7 Inch |

MicroClamp, uClamp and μ Clamp are marks of Semtech Corporation

Tape and Reel Specification

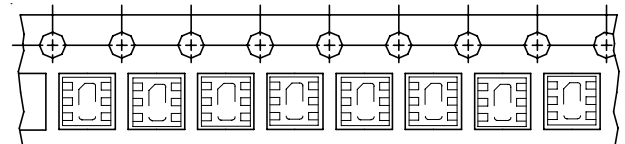
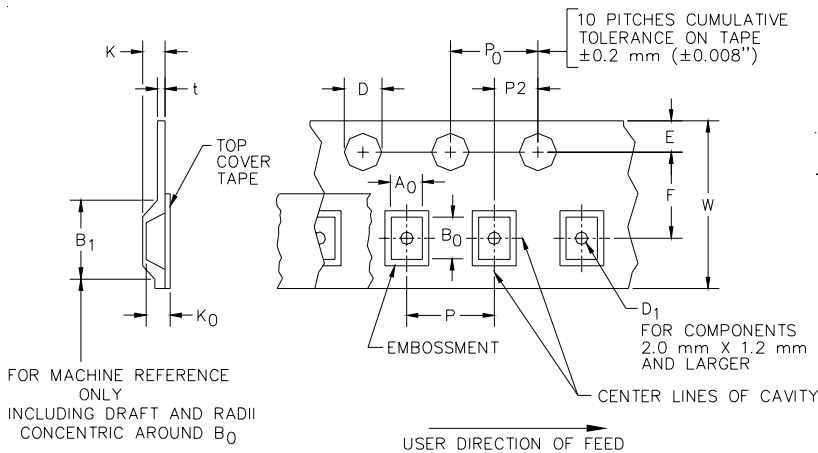

Device Orientation in Tape
(Pin 1 upper left towards sprocket holes)

| A0 | B0 | K0 |
|-----------------|-----------------|-----------------|
| 1.78 +/-0.10 mm | 1.78 +/-0.10 mm | 0.69 +/-0.10 mm |

| Tape Width | B, (Max) | D | D1 | E | F | K (MAX) | P | P0 | P2 | T(MAX) | W |
|------------|---------------|---|--------------------------|---|---------------------------------------|---------------|--------------------------------------|--------------------------------------|---------------------------------------|---------------|--|
| 8 mm | 4.2 mm (.165) | 1.5 + 0.1 mm - 0.0 mm (0.59 + 0.005 - .000) | 0.8 mm ± 0.05 (.031) | 1.750 ± 0.10 mm (.069 ± 0.004) | 3.5 ± 0.05 mm (.138 ± 0.002) | 2.4 mm (.094) | 4.0 ± 0.1 mm (.157 ± 0.004) | 4.0 ± 0.1 mm (.157 ± 0.004) | 2.0 ± 0.05 mm (.079 ± 0.002) | 0.4 mm (.016) | 8.0 mm + 0.3 mm - 0.1 mm (.312 ± 0.012) |

Contact Information

Semtech Corporation
Protection Products Division
200 Flynn Rd., Camarillo, CA 93012
Phone: (805)498-2111 FAX (805)498-3804

Компания «Океан Электроники» предлагает заключение долгосрочных отношений при поставках импортных электронных компонентов на взаимовыгодных условиях!

Наши преимущества:

- Поставка оригинальных импортных электронных компонентов напрямую с производств Америки, Европы и Азии, а так же с крупнейших складов мира;
- Широкая линейка поставок активных и пассивных импортных электронных компонентов (более 30 млн. наименований);
- Поставка сложных, дефицитных, либо снятых с производства позиций;
- Оперативные сроки поставки под заказ (от 5 рабочих дней);
- Экспресс доставка в любую точку России;
- Помощь Конструкторского Отдела и консультации квалифицированных инженеров;
- Техническая поддержка проекта, помощь в подборе аналогов, поставка прототипов;
- Поставка электронных компонентов под контролем ВП;
- Система менеджмента качества сертифицирована по Международному стандарту ISO 9001;
- При необходимости вся продукция военного и аэрокосмического назначения проходит испытания и сертификацию в лаборатории (по согласованию с заказчиком);
- Поставка специализированных компонентов военного и аэрокосмического уровня качества (Xilinx, Altera, Analog Devices, Intersil, Interpoint, Microsemi, Actel, Aeroflex, Peregrine, VPT, Syfer, Eurofarad, Texas Instruments, MS Kennedy, Miteq, Cobham, E2V, MA-COM, Hittite, Mini-Circuits, General Dynamics и др.);

Компания «Океан Электроники» является официальным дистрибьютором и эксклюзивным представителем в России одного из крупнейших производителей разъемов военного и аэрокосмического назначения «JONHON», а так же официальным дистрибьютором и эксклюзивным представителем в России производителя высокотехнологичных и надежных решений для передачи СВЧ сигналов «FORSTAR».



JONHON

«JONHON» (основан в 1970 г.)

Разъемы специального, военного и аэрокосмического назначения:

(Применяются в военной, авиационной, аэрокосмической, морской, железнодорожной, горно- и нефтедобывающей отраслях промышленности)

«FORSTAR» (основан в 1998 г.)

ВЧ соединители, коаксиальные кабели, кабельные сборки и микроволновые компоненты:

(Применяются в телекоммуникациях гражданского и специального назначения, в средствах связи, РЛС, а так же военной, авиационной и аэрокосмической отраслях промышленности).



Телефон: 8 (812) 309-75-97 (многоканальный)

Факс: 8 (812) 320-03-32

Электронная почта: ocean@oceanchips.ru

Web: <http://oceanchips.ru/>

Адрес: 198099, г. Санкт-Петербург, ул. Калинина, д. 2, корп. 4, лит. А