

Doubler Charge Pump with Low Noise Linear Regulator

DESCRIPTION

Demonstration Circuit DC249 is a doubler charge pump and linear regulator that produces a regulated, low noise output voltage from an input voltage ranging from 1.8V to 4.4V. Two fixed output voltages of 3.3V and 5V are available. In addition, an adjustable output voltage version is available with an output voltage range of 2.5V to 5.5V. The LTC[®]1682 family can supply up to 50mA of output current. The circuit requires only small surface mount components, resulting in very small board area. The power supply circuit is particularly useful in battery-

powered systems that require extremely low output voltage noise and small size.

A DC249 demo board is available for the LTC1682CMS8, LTC1682CMS8-3.3 and the LTC1682CMS8-5. The LTC1682CMS8 demo board does not include the feedback resistors used to set the output voltage. The user must calculate the resistor values based on the required output voltage and add them to the board. **Gerber files for this circuit board are available. Call the LTC factory.**

LT, LTC and LT are registered trademarks of Linear Technology Corporation.
 Burst Mode is a trademark of Linear Technology Corporation.

PERFORMANCE SUMMARY

PARAMETER	CONDITIONS	MIN	TYP	MAX	UNITS
V _{IN} Operating Voltage		1.8		4.4	V
I _{VIN} Shutdown Current	$\overline{\text{SHDN}} = 0\text{V}$		1	5	μA
I _{VIN} Quiescent Current	I _{OUT} = 0mA, Burst Mode™ Operation, $\overline{\text{SHDN}} > 1.6\text{V}$		150	250	μA
V _{OUT} RMS Output Noise	LTC1682-3.3: I _{OUT} = 10mA, 10Hz ≤ f ≤ 100kHz, C _{FILT} = 1nF LTC1682-5: I _{OUT} = 10mA, 10Hz ≤ f ≤ 100kHz, C _{FILT} = 1nF		58 64		μV_{RMS} μV_{RMS}
V _{OUT} Wideband Output Noise	I _{OUT} = 10mA, $\overline{\text{SHDN}} > 1.6\text{V}$, BW = 10Hz ≤ f ≤ 2.5MHz LTC1682-3.3, V _{IN} = 3V LTC1682-5, V _{IN} = 3V LTC1682 Adjustable, V _{OUT} = 5V, V _{IN} = 3V		500 600 800		$\mu\text{V}_{\text{P-P}}$ $\mu\text{V}_{\text{P-P}}$ $\mu\text{V}_{\text{P-P}}$
V _{OUT} (LTC1682-3.3)	$\overline{\text{SHDN}} > 1.6\text{V}$	3.23	3.30	3.37	V
V _{OUT} (LTC1682-5)	$\overline{\text{SHDN}} > 1.6\text{V}$	4.9	5.0	5.1	V
V _{OUT} (LTC1682)	$\overline{\text{SHDN}} > 1.6\text{V}$, Internal Reference Tolerance	-2		2	%

TYPICAL PERFORMANCE CHARACTERISTICS AND BOARD PHOTO

Typical Output Noise

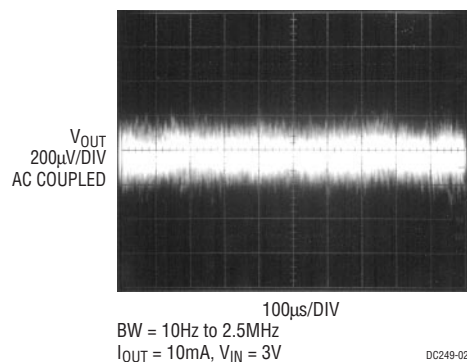

Board Photo



PACKAGE AND SCHEMATIC DIAGRAMS

LTC1682 Schematic Diagram

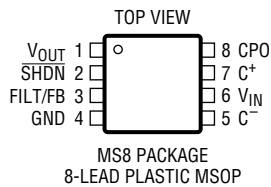
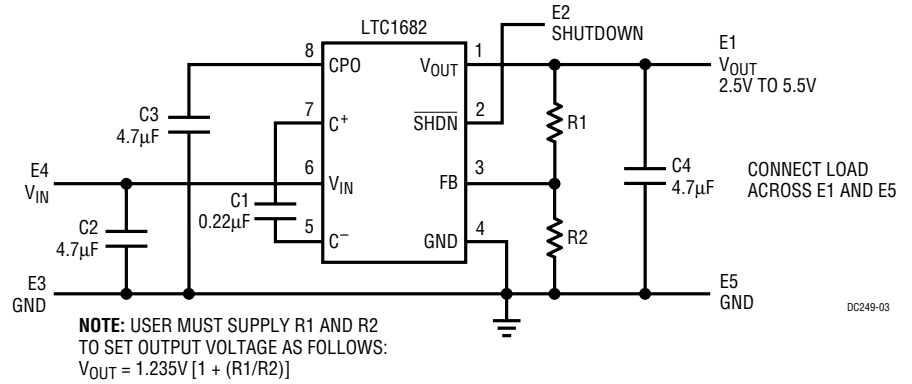

LTC1682CMS8
LTC1682CMS8-3.3
LTC1682CMS8-5

LTC1682-3.3/LTC1682-5 Schematic Diagram

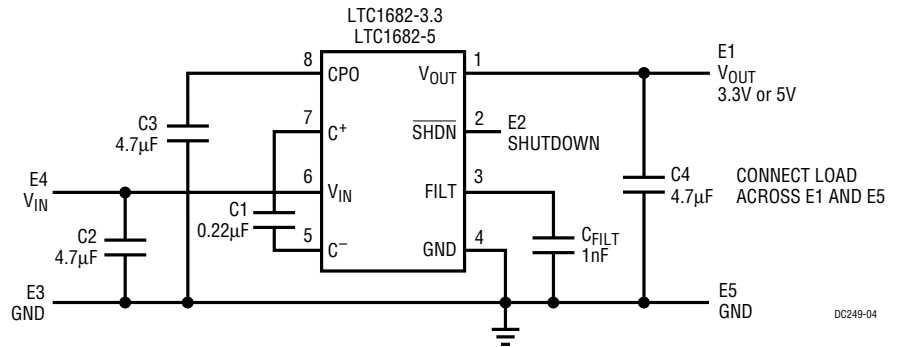

PARTS LIST

REFERENCE DESIGNATOR	QUANTITY	PART NUMBER	DESCRIPTION	VENDOR	TELEPHONE
C1	1	0805YC224KAT2A	0.22µF 16V 10% X7R Capacitor	AVX	(843) 946-0362
C2, C4	2	0805ZG475ZAT2A	4.7µF 10V Y5V Capacitor	AVX	(843) 946-0362
C3	1	1206YG475ZAT2A	4.7µF 16V Y5V Capacitor	AVX	(843) 946-0362
E1 to E5	5	2501-2	0.090" Turret Testpoint	Mill-Max	(516) 922-6000
R1, R2	2	TBD	TBD Resistor	TBD	
U1	1	LTC1682MS8 LTC1682MS8-5 LTC1682MS8-3.3	8-Lead MSOP IC Version A 8-Lead MSOP IC Version B 8-Lead MSOP IC Version C	LTC	(408) 432-1900

NOTE: For LTC1682-3.3 and LTC1682-5: Replace R2 with a 1nF 16V 10% X7R ceramic capacitor (AVX 0603YC102KAT2A) and omit R1.

QUICK START GUIDE

DC249 is easily set up for evaluating the LTC1682 low noise converter family. Follow the procedure outlined below for proper operation.

1. Connect the input power supply, output load and meters as shown in Figure 1. For best accuracy, it is important to connect true RMS reading voltmeters directly to the PCB terminals when the input and output voltages are to be measured. True RMS reading ammeters should also be used for current measurements.
2. Increase the input voltage to the desired level. The minimum input voltage is related to the required output voltage and current. For example, if the required output voltage is 5V, then the CPO voltage at Pin 8 of the LTC1682 must be above 5V to prevent dropout. A reasonable CPO voltage would be 5.4V at low output currents. The minimum input voltage requirement would be 1/2 this value or about 2.7V.
3. The part can be shut down or enabled by controlling the SHDN pin. When this pin is connected to ground, the part is shut down. When connected to V_{IN} , the part is enabled. The SHDN pin can be controlled by a pulse generator to observe power-up and power-down characteristics. The output of the pulse generator is set to swing between 0.4V and 1.6V.

4. When performing noise measurements (Figure 2), the load should be soldered directly to the board between E1 and E5. Long leads connecting to a load may introduce noise. Do not connect DC voltmeters to E1 when performing noise tests and connect SHDN directly to V_{IN} .

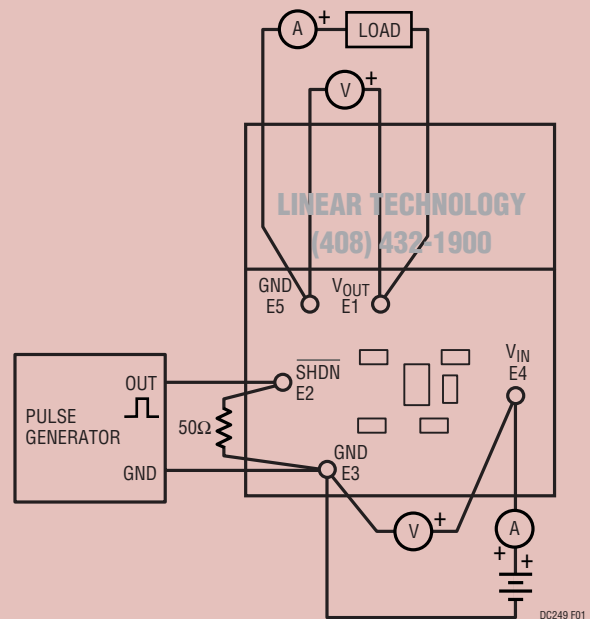

Figure 1. Proper Measurement Setup

OPERATION (See the LTC1682 Block Diagrams)

The LTC1682 family uses a switched capacitor charge pump to generate voltage at the CPO (Charge Pump Output) pin of approximately $2V_{IN}$. This voltage powers an internal, low dropout linear regulator that supplies a regulated output at V_{OUT} . Internal comparators are used to sense the CPO and V_{IN} voltages for power-up conditioning. The output current is sensed to determine the charge pump operating mode. A trimmed internal bandgap is used as the voltage reference and a trimmed internal oscillator is used to control the charge pump switches.

The charge pump is configured as a doubler that uses one external flying capacitor. When enabled, a 2-phase nonoverlapping clock controls the charge pump switches. At start-up, the LDO is disabled and the load is removed from the CPO. When the CPO reaches $1.75V_{IN}$, the LDO is enabled. If the CPO voltage falls below $1.45V_{IN}$, the LDO is disabled. Generally, the charge pump runs open loop with continuous clocking for low noise. If the CPO voltage is greater than $1.95V_{IN}$ and I_{OUT} is less than $100\mu A$, the charge pump will use Burst Mode operation for increased efficiency but higher output noise. In Burst Mode operation, the clock is disabled when the CPO voltage reaches $1.95V_{IN}$ and enabled when the CPO voltage droops by about $100mV$. The switching frequency is precisely controlled to ensure that the frequency is above $455kHz$ and at the optimum rate to ensure maximum efficiency. The switch edge rates are also controlled to minimize noise. The effective output resistance at the CPO pin is dependent on the voltage at V_{IN} , the voltage at the CPO pin and the junction temperature.

The LDO is used to filter the ripple on the CPO voltage and to set an output voltage independent of the CPO voltage.

The LDO requires a capacitor on V_{OUT} for stability and improved load transient response.

Output Voltage Selection

The LTC1682 output voltage is set using an external resistor divider. The output voltage is determined by the following formula:

$$V_{OUT} = 1.235V[1 + (R1/R2)]$$

The output voltage range is 2.5V to 5.5V.

Capacitor Selection

For best performance it is recommended that low ESR capacitors be used for C2, C3 and C4 to reduce noise and ripple. C2 must be $>2\mu F$, and C3 must be equal to or greater than C2. C4 is dependent on the source impedance. C4 should be $>2\mu F$, since the charge pump demands large instantaneous currents that may induce ripple on a common voltage rail.

A ceramic capacitor with a value of $0.22\mu F$ is recommended for the flying capacitor C1. At low load or high V_{IN} , a smaller capacitor could be used to reduce ripple on CPO, which would be reflected as lower ripple on V_{OUT} .

Measuring Output Noise

Measuring the LTC1682's low noise levels requires care. Figure 2 shows a test setup for taking the measurement. Good connection and signal handling technique should yield about $500\mu V_{P-P}$ over a $2.5MHz$ bandwidth. The noise measurement involves AC coupling the LTC1682 output into the test setup's input and terminating this connection with 50Ω . Coaxial connections must be maintained to preserve measurement integrity.

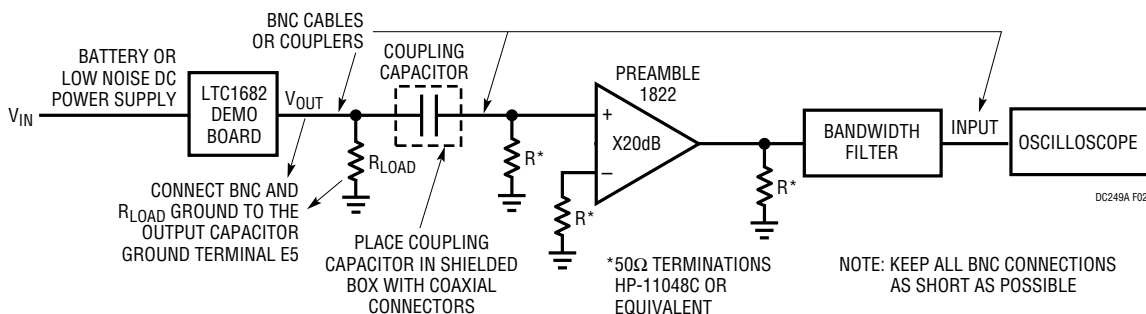
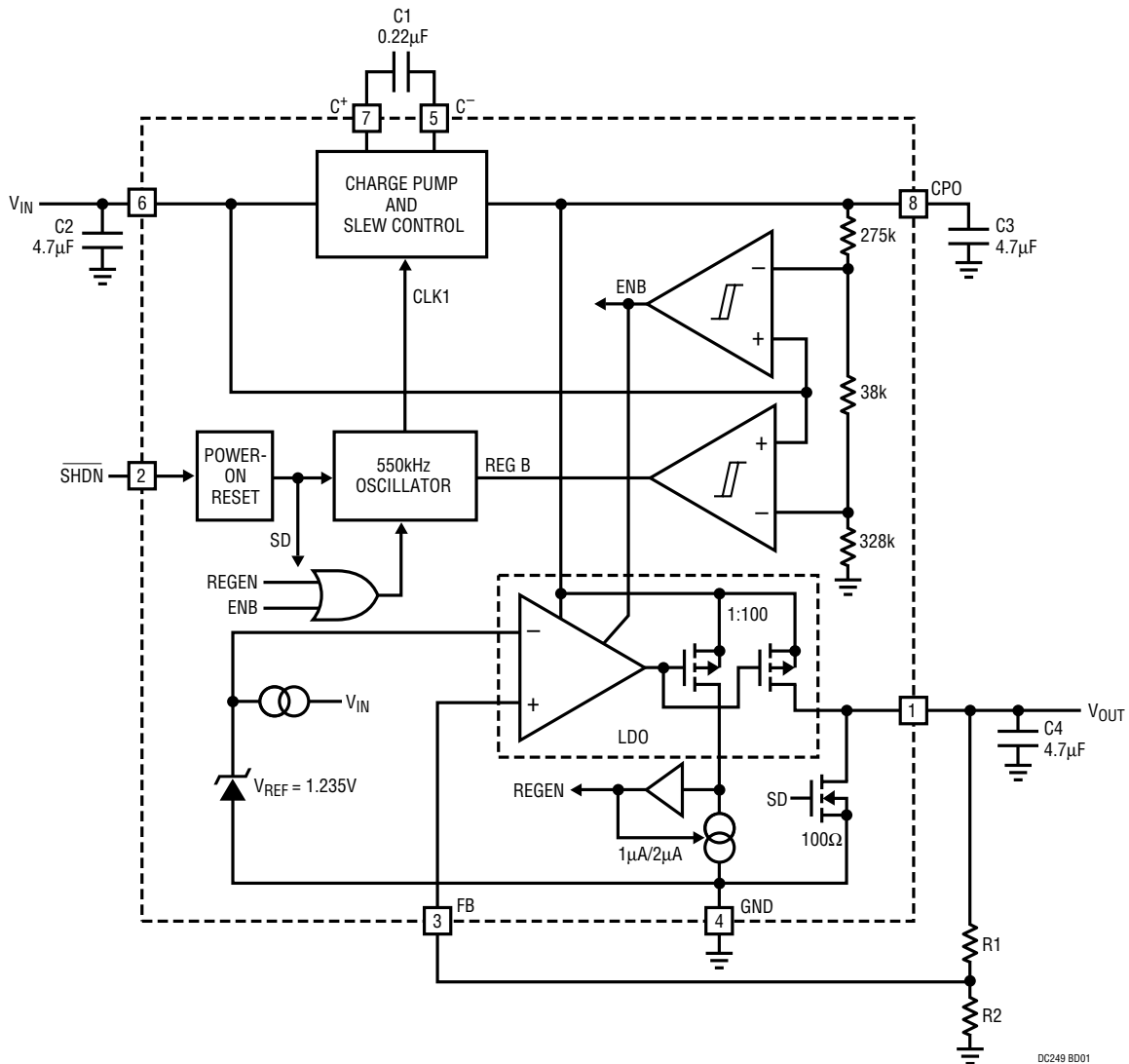

Figure 2. LTC1682 Noise Measurement

BLOCK DIAGRAMS

LTC1682 Block Diagram



DC249 BD01

BLOCK DIAGRAMS

LTC1682-3.3/LTC1682-5 Block Diagram

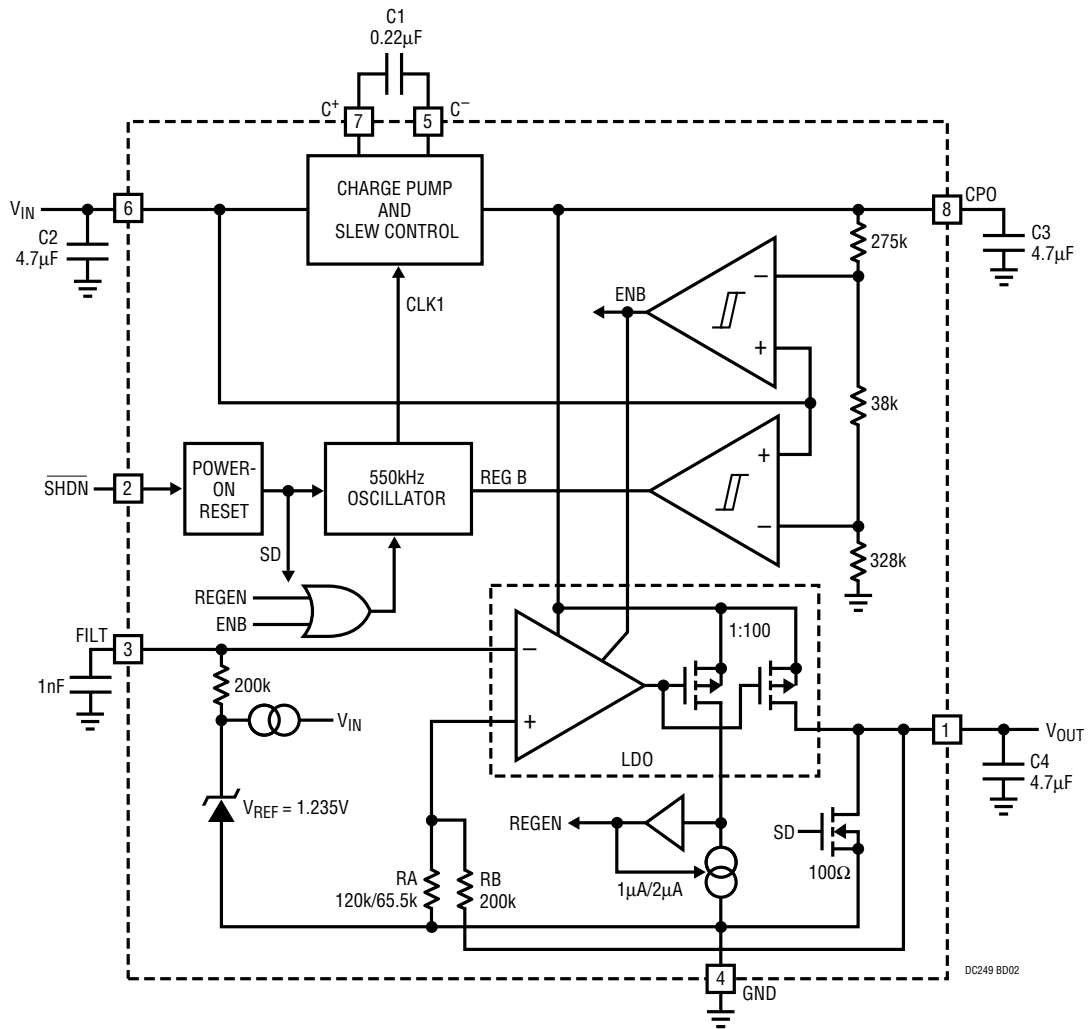

PCB LAYOUT AND FILM

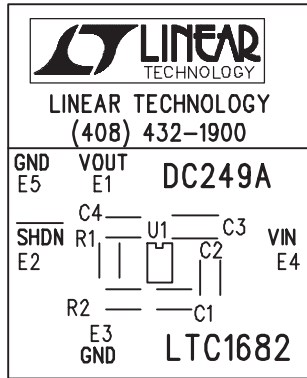

DC249A SIL

Silkscreen Top

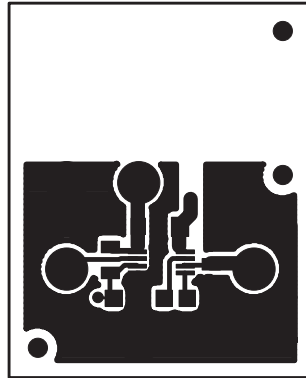

DC249A COMP

Component Side

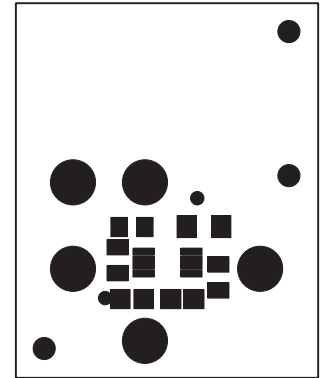

DC249A TSM

Solder Mask Top

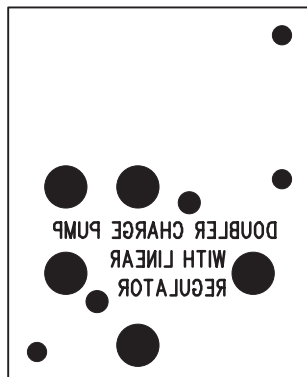

DC249A BL

Solder Side Copper

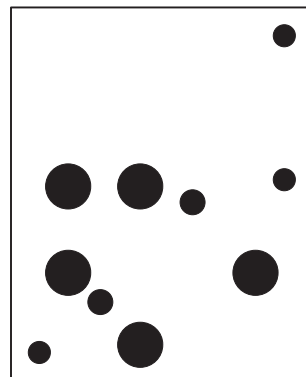

DC249A BSM

Solder Mask Bottom

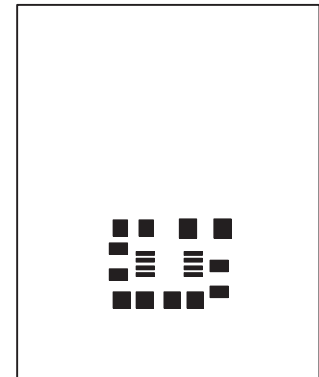

DC249A TSP

Solder Paste Top

DEMO MANUAL DC249

LOW NOISE CONVERTER

PC FAB DRAWING

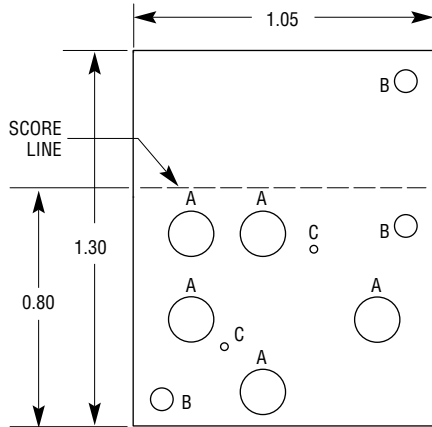

NOTES: UNLESS OTHERWISE SPECIFIED

1. MATERIAL: FR4 OR EQUIVALENT, 2 OZ COPPER CLAD THICKNESS 0.062 ±0.006 TOTAL OF 2 LAYERS
2. FINISH: ALL PLATED HOLES 0.001 MIN/0.0015 MAX COPPER PLATE ELECTRODEPOSITED TIN-LEAD COMPOSITION BEFORE REFLOW, SOLDER MASK OVER BARE COPPER (SMOBC)
3. SOLDER MASK: BOTH SIDES USING LPI OR EQUIVALENT
4. SILKSCREEN: USING WHITE NONCONDUCTIVE EPOXY INK
5. UNUSED SMD COMPONENT PADS SHOULD BE FREE OF SOLDER
6. FILL UP ALL VIAS WITH SOLDER
7. ALL DIMENSIONS ARE IN INCHES

SYMBOL	DIAMETER	NUMBER OF HOLES	PLATED
A	0.094	5	YES
B	0.07	3	NO
C	0.02	2	YES

DC249A FD

Компания «Океан Электроники» предлагает заключение долгосрочных отношений при поставках импортных электронных компонентов на взаимовыгодных условиях!

Наши преимущества:

- Поставка оригинальных импортных электронных компонентов напрямую с производств Америки, Европы и Азии, а так же с крупнейших складов мира;
- Широкая линейка поставок активных и пассивных импортных электронных компонентов (более 30 млн. наименований);
- Поставка сложных, дефицитных, либо снятых с производства позиций;
- Оперативные сроки поставки под заказ (от 5 рабочих дней);
- Экспресс доставка в любую точку России;
- Помощь Конструкторского Отдела и консультации квалифицированных инженеров;
- Техническая поддержка проекта, помощь в подборе аналогов, поставка прототипов;
- Поставка электронных компонентов под контролем ВП;
- Система менеджмента качества сертифицирована по Международному стандарту ISO 9001;
- При необходимости вся продукция военного и аэрокосмического назначения проходит испытания и сертификацию в лаборатории (по согласованию с заказчиком);
- Поставка специализированных компонентов военного и аэрокосмического уровня качества (Xilinx, Altera, Analog Devices, Intersil, Interpoint, Microsemi, Actel, Aeroflex, Peregrine, VPT, Syfer, Eurofarad, Texas Instruments, MS Kennedy, Miteq, Cobham, E2V, MA-COM, Hittite, Mini-Circuits, General Dynamics и др.);

Компания «Океан Электроники» является официальным дистрибьютором и эксклюзивным представителем в России одного из крупнейших производителей разъемов военного и аэрокосмического назначения «**JONHON**», а так же официальным дистрибьютором и эксклюзивным представителем в России производителя высокотехнологичных и надежных решений для передачи СВЧ сигналов «**FORSTAR**».



JONHON

«**JONHON**» (основан в 1970 г.)

Разъемы специального, военного и аэрокосмического назначения:

(Применяются в военной, авиационной, аэрокосмической, морской, железнодорожной, горно- и нефтедобывающей отраслях промышленности)

«**FORSTAR**» (основан в 1998 г.)

ВЧ соединители, коаксиальные кабели,
кабельные сборки и микроволновые компоненты:

(Применяются в телекоммуникациях гражданского и специального назначения, в средствах связи, РЛС, а так же военной, авиационной и аэрокосмической отраслях промышленности).



Телефон: 8 (812) 309-75-97 (многоканальный)

Факс: 8 (812) 320-03-32

Электронная почта: ocean@oceanchips.ru

Web: <http://oceanchips.ru/>

Адрес: 198099, г. Санкт-Петербург, ул. Калинина, д. 2, корп. 4, лит. А