



# JESD204B Intel® FPGA IP User Guide

Updated for Intel® Quartus® Prime Design Suite: **19.4**

IP Version: **19.2.0**



[Subscribe](#)

[Send Feedback](#)

**UG-01142 | 2020.03.03**

Latest document on the web: [PDF](#) | [HTML](#)



# Contents

---

- 1. JESD204B IP Quick Reference..... 4**
- 2. About the JESD204B Intel FPGA IP..... 6**
  - 2.1. Release Information..... 8
  - 2.2. Device Family Support..... 8
  - 2.3. Datapath Modes..... 9
  - 2.4. IP Variation..... 9
  - 2.5. JESD204B IP Configuration..... 10
    - 2.5.1. Run-Time Configuration..... 11
  - 2.6. Channel Bonding..... 12
  - 2.7. Performance and Resource Utilization..... 14
- 3. Getting Started..... 20**
  - 3.1. Introduction to Intel FPGA IP Cores..... 20
  - 3.2. Installing and Licensing Intel FPGA IP Cores..... 21
  - 3.3. Intel FPGA IP Evaluation Mode..... 22
  - 3.4. Upgrading IP Cores..... 24
  - 3.5. IP Catalog and Parameter Editor..... 28
  - 3.6. Design Walkthrough..... 28
    - 3.6.1. Creating a New Intel Quartus Prime Project..... 28
    - 3.6.2. Parameterizing and Generating the IP..... 29
    - 3.6.3. Compiling the JESD204B IP Core Design..... 30
    - 3.6.4. Programming an FPGA Device..... 31
  - 3.7. JESD204B Design Examples..... 31
  - 3.8. JESD204B IP Design Considerations..... 31
    - 3.8.1. Integrating the JESD204B IP in Platform Designer..... 31
    - 3.8.2. Pin Assignments..... 33
    - 3.8.3. Adding External Transceiver PLLs..... 33
    - 3.8.4. Timing Constraints For Input Clocks..... 33
  - 3.9. JESD204B Intel FPGA IP Parameters..... 36
  - 3.10. JESD204B IP Component Files..... 41
  - 3.11. JESD204B IP Testbench..... 41
    - 3.11.1. Generating and Simulating the IP Testbench..... 42
    - 3.11.2. Testbench Simulation Flow..... 45
- 4. JESD204B IP Functional Description..... 46**
  - 4.1. Transmitter..... 48
    - 4.1.1. TX Data Link Layer..... 49
    - 4.1.2. TX PHY Layer..... 52
  - 4.2. Receiver..... 52
    - 4.2.1. RX Data Link Layer..... 53
    - 4.2.2. RX PHY Layer..... 56
  - 4.3. Operation..... 56
    - 4.3.1. Operating Modes..... 57
    - 4.3.2. Scrambler/Descrambler..... 59
    - 4.3.3. SYNC\_N Signal..... 60
    - 4.3.4. Link Reinitialization..... 61
    - 4.3.5. Link Startup Sequence..... 62



4.3.6. Error Reporting Through SYNC_N Signal.....	63
4.4. Clocking Scheme.....	63
4.4.1. Device Clock.....	65
4.4.2. Link Clock.....	67
4.4.3. Local MultiFrame Clock.....	68
4.4.4. Clock Correlation.....	69
4.5. Reset Scheme.....	70
4.5.1. Reset Sequence.....	72
4.5.2. ADC–FPGA Subsystem Reset Sequence.....	72
4.5.3. FPGA–DAC Subsystem Reset Sequence.....	74
4.6. Signals.....	76
4.6.1. Transmitter Signals.....	77
4.6.2. Receiver Signals.....	89
4.7. Registers.....	98
4.7.1. Register Access Type Convention.....	99
4.7.2. Transmitter Registers.....	99
4.7.3. Receiver Registers.....	123
<b>5. JESD204B IP Deterministic Latency Implementation Guidelines.....</b>	<b>149</b>
5.1. Constraining Incoming SYSREF Signal.....	149
5.2. Programmable RBD Offset.....	150
5.3. Programmable LMFC Offset.....	153
5.4. Maintaining Deterministic Latency during Link Reinitialization.....	157
<b>6. JESD204B IP Debug Guidelines.....</b>	<b>159</b>
6.1. Clocking Scheme.....	159
6.2. JESD204B Parameters.....	159
6.3. SPI Programming.....	159
6.4. Converter and FPGA Operating Conditions.....	160
6.5. Signal Polarity and FPGA Pin Assignment.....	160
6.6. Creating a Signal Tap Debug File to Match Your Design Hierarchy .....	161
6.7. Debugging JESD204B Link Using System Console.....	162
<b>7. JESD204B Intel FPGA IP User Guide Archives.....</b>	<b>169</b>
<b>8. Document Revision History for the JESD204B Intel FPGA IP User Guide.....</b>	<b>170</b>

## 1. JESD204B IP Quick Reference

The JESD204B Intel FPGA IP is a high-speed point-to-point serial interface intellectual property (IP).

**Note:** For system requirements and installation instructions, refer to *Intel FPGA Software Installation & Licensing*.

**Table 1. Brief Information About the JESD204B IP**

Item	Description
Protocol Features	<ul style="list-style-type: none"> <li>Joint Electron Device Engineering Council (JEDEC) JESD204B.01, 2012 standard release specification</li> <li>Device subclass:               <ul style="list-style-type: none"> <li>Subclass 0—Backwards compatible to JESD204A.</li> <li>Subclass 1—Uses <code>SYSREF</code> signal to support deterministic latency.</li> <li>Subclass 2—Uses <code>SYNC_N</code> detection to support deterministic latency.</li> </ul> </li> </ul>
Core Features	<ul style="list-style-type: none"> <li>Run-time configuration of parameters L, M, and F</li> <li>Data rate of up to 12.5 gigabits per second (Gbps)—per JESD204B specification</li> <li>Data rate of up to 19.2 Gbps—not certified per JESD204B specification (uncharacterized support)</li> <li>Single or multiple lanes (up to 8 lanes per link)</li> <li>Serial lane alignment and monitoring</li> <li>Lane synchronization</li> <li>Modular design that supports multidevice synchronization</li> <li>MAC and PHY partitioning</li> <li>Deterministic latency support</li> <li>8B/10B encoding</li> <li>Scrambling/Descrambling</li> <li>Avalon® Streaming (Avalon-ST) interface for transmit and receive datapaths</li> <li>Avalon Memory-Mapped (Avalon-MM) interface for Configuration and Status registers (CSR)</li> <li>Dynamic generation of simulation testbench</li> </ul>
Typical Application	<ul style="list-style-type: none"> <li>Wireless communication equipment</li> <li>Broadcast equipment</li> <li>Military equipment</li> <li>Medical equipment</li> <li>Test and measurement equipment</li> </ul>
Device Family Support	<ul style="list-style-type: none"> <li>Intel Agilex™ devices (E-tile)</li> <li>Intel Cyclone® 10 GX FPGA devices</li> <li>Intel Stratix® 10 FPGA devices (L-tile/H-tile/E-tile)</li> <li>Intel Arria® 10 FPGA devices</li> <li>Stratix V FPGA devices</li> </ul>

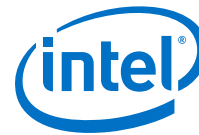
*continued...*



Item	Description
	<ul style="list-style-type: none"> <li>• Arria V FPGA devices</li> <li>• Arria V GZ FPGA devices</li> <li>• Cyclone V FPGA devices</li> </ul>
Design Tools	<ul style="list-style-type: none"> <li>• Platform Designer parameter editor in the Intel Quartus® Prime software for design creation and compilation</li> <li>• Timing Analyzer in the Intel Quartus Prime software for timing analysis</li> <li>• ModelSim* - Intel FPGA Edition, Riviera-PRO*, VCS*/VCS MX, NCSim, and Xcelium* Parallel simulator software for design simulation or synthesis</li> </ul>

### Related Information

- [Design Examples for JESD204B IP Core User Guide](#)  
Provides information about design examples for Arria V, Cyclone V, Stratix V, and Intel Arria 10 devices using Intel Quartus Prime Standard Edition software.
- [JESD204B Intel Arria 10 FPGA IP Design Example User Guide](#)
- [JESD204B Intel Stratix 10 FPGA IP Design Example User Guide](#)
- [JESD204B Intel Cyclone 10 GX FPGA IP Design Example User Guide](#)
- [JESD204B Intel Agilex FPGA IP Design Example User Guide](#)
- [Intel FPGA Software Installation and Licensing](#)
- [JESD204B IP Core Release Notes](#)
- [Errata for JESD204B IP Core in the Knowledge Base](#)
- [AN803: Implementing ADC-Intel Arria 10 Multi-Link Design with JESD204B RX IP Core](#)
- [AN804: Implementing ADC-Intel Stratix 10 Multi-Link Design with JESD204B RX IP Core](#)
- [JESD204B Intel FPGA IP User Guide Archives](#) on page 169  
Provides a list of user guides for previous versions of the JESD204B IP core.



## 2. About the JESD204B Intel FPGA IP

---

The JESD204B Intel FPGA IP is a high-speed point-to-point serial interface for digital-to-analog (DAC) or analog-to-digital (ADC) converters to transfer data to FPGA devices. This unidirectional serial interface runs at a maximum data rate of 17.4 Gbps. This protocol offers higher bandwidth, low I/O count and supports scalability in both number of lanes and data rates. The JESD204B Intel FPGA IP addresses multi-device synchronization by introducing Subclass 1 and Subclass 2 to achieve deterministic latency.

*Note:* The full product name, JESD204B Intel FPGA IP, is shortened to JESD204B IP in this document.

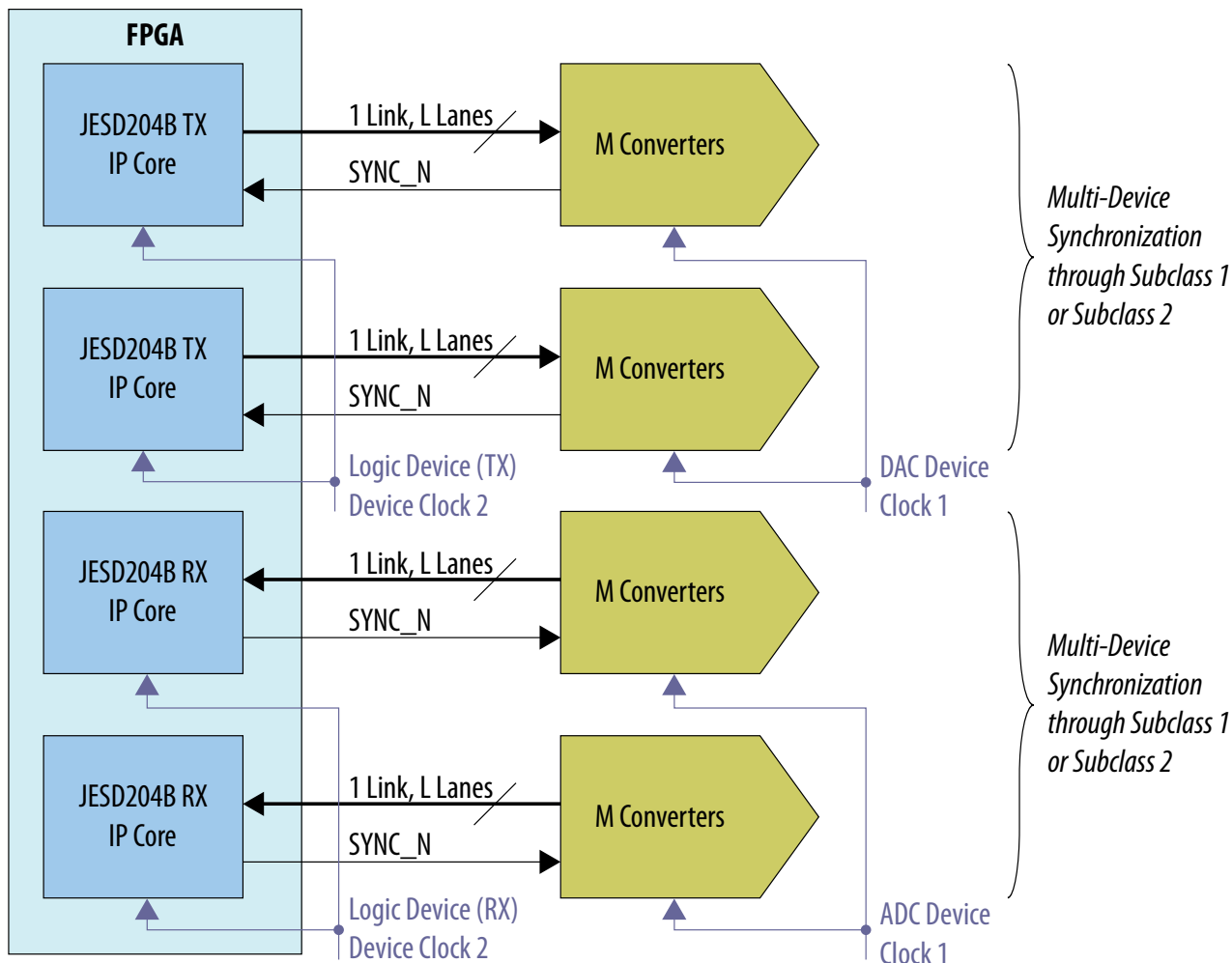
The JESD204B IP incorporates:

- Media access control (MAC)—data link layer (DLL) block that controls the link states and character replacement.
- Physical layer (PHY)—physical coding sublayer (PCS) and physical media attachment (PMA) block.

The JESD204B IP does not incorporate the Transport Layer (TL) that controls the frame assembly and disassembly. The TL and test components are provided as part of a design example component where you can customize the design for different converter devices.

**Figure 1. Typical System Application for JESD204B IP**

The JESD204B IP uses the Avalon-ST source and sink interfaces, with unidirectional flow of data, to transmit and receive data on the FPGA fabric interface.



Key features of the JESD204B IP:

- Data rate of up to 19.2 Gbps (characterization up to 12.5 G)
- Run-time JESD204B parameter configuration (L, M, F, S, N, K, CS, CF)
- MAC and PHY partitioning for portability
- Subclass 0 mode for backward compatibility to JESD204A
- Subclass 1 mode for deterministic latency support (using `SYSPREF`) between the ADC/DAC and logic device
- Subclass 2 mode for deterministic latency support (using `SYNC_N`) between the ADC/DAC and logic device
- Multi-device synchronization



### Related Information

- [V-Series Transceiver PHY User Guide](#)
- [Intel Arria 10 Transceiver PHY User Guide](#)
- [Intel Cyclone 10 GX Transceiver PHY User Guide](#)
- [Intel Stratix 10 L- and H-tile Transceiver PHY User Guide](#)
- [E-tile Transceiver PHY User Guide](#)
- [Intel Agilex Device Datasheet](#)
- [Intel Stratix 10 Device Datasheet](#)
- [Intel Arria 10 Device Datasheet](#)

## 2.1. Release Information

IP versions are the same as the Intel Quartus Prime Design Suite software versions up to v19.1. From Intel Quartus Prime Design Suite software version 19.2 or later, IP cores have a new IP versioning scheme.

The IP versioning scheme (X.Y.Z) number changes from one software version to another. A change in:

- X indicates a major revision of the IP. If you update your Intel Quartus Prime software, you must regenerate the IP.
- Y indicates the IP includes new features. Regenerate your IP to include these new features.
- Z indicates the IP includes minor changes. Regenerate your IP to include these changes.

**Table 2. JESD204B IP Release Information**

Item	Description
IP Version	19.3.0
Intel Quartus Prime Version	19.4
Release Date	December 2019
Ordering Code	IP-JESD204B

## 2.2. Device Family Support

**Table 3. Intel Device Family Support**

Device Family	Support Level
Intel Agilex (E-tile)	Advance
Intel Stratix 10 (E-tile, H-tile, and L-tile)	Final
Intel Arria 10	Final
Intel Cyclone 10 GX	Final
<i>continued...</i>	





Device Family	Support Level
Stratix V	Final
Arria V	Final
Cyclone V	Final

The following terms define device support levels for Intel FPGA IP cores:

- **Advance support**—the IP core is available for simulation and compilation for this device family. Timing models include initial engineering estimates of delays based on early post-layout information. The timing models are subject to change as silicon testing improves the correlation between the actual silicon and the timing models. You can use this IP core for system architecture and resource utilization studies, simulation, pinout, system latency assessments, basic timing assessments (pipeline budgeting), and I/O transfer strategy (data-path width, burst depth, I/O standards tradeoffs).
- **Preliminary support**—the IP core is verified with preliminary timing models for this device family. The IP core meets all functional requirements, but might still be undergoing timing analysis for the device family. It can be used in production designs with caution.
- **Final support**—the IP core is verified with final timing models for this device family. The IP core meets all functional and timing requirements for the device family and can be used in production designs.

## 2.3. Datapath Modes

The JESD204B IP supports TX-only, RX-only, and Duplex (TX and RX) mode. The IP is a unidirectional protocol where interfacing to ADC utilizes the transceiver RX path and interfacing to DAC utilizes the transceiver TX path.

The JESD204B IP generates a single link with a single lane and up to a maximum of 8 lanes. If there are two ADC links that need to be synchronized, you have to generate two JESD204B IP cores and then manage the deterministic latency and synchronization signals, like `SYSREF` and `SYNC_N`, at your custom wrapper level.

The JESD204B IP supports duplex mode only if the LMF configuration for ADC (RX) is the same as DAC (TX) and with the same data rate. This use case is mainly for prototyping with internal serial loopback mode. This is because typically as a unidirectional protocol, the LMF configuration of converter devices for both DAC and ADC are not identical.

## 2.4. IP Variation

The JESD204B IP has three core variations:

- JESD204B MAC only
- JESD204B PHY only
- JESD204B MAC and PHY



In a subsystem where there are multiple ADC and DAC converters, you need to use the Intel Quartus Prime software to merge the transceivers and group them into the transceiver architecture. For example, to create two instances of the JESD204B TX IP with four lanes each and four instances of the JESD204B RX IP with two lanes each, you can apply one of the following options:

- MAC and PHY option
  1. Generate JESD204B TX IP with four lanes and JESD204B RX IP with two lanes.
  2. Instantiate the desired components.
  3. Use the Intel Quartus Prime software to merge the PHY lanes.
- MAC only and PHY only option—based on the configuration above, there are a total of eight lanes in duplex mode.
  1. Generate the JESD204B Duplex PHY with a total of eight lanes. (TX skew is reduced in this configuration as the channels are bonded).
  2. Generate the JESD204B TX MAC with four lanes and instantiate it two times.
  3. Generate the JESD204B RX MAC with two lanes and instantiate it four times.
  4. Create a wrapper to connect the JESD204B TX MAC and RX MAC with the JESD204B Duplex PHY.

**Note:** If the data rate for TX and RX is different, the transceiver does not allow duplex mode to generate a duplex PHY. In this case, you have to generate a RX-only PHY on the RX data rate and a TX-only PHY on the TX data rate.

## 2.5. JESD204B IP Configuration

**Table 5. JESD204B IP Configuration**

Symbol	Description	Value
L	Number of lanes per converter device	1-8
M	Number of converters per device	1-256
F	Number of octets per frame	<ul style="list-style-type: none"><li>• 1-256 (for Intel Stratix 10 devices only)</li><li>• 1, 2, 4-256 (for non Intel Stratix 10 devices)</li></ul>
S	Number of transmitted samples per converter per frame	1-32
N	Number of conversion bits per converter	1-32
N'	Number of transmitted bits per sample (JESD204 word size, which is in nibble group)	1-32
K	Number of frames per multiframe	$17/F \leq K \leq 32$ ; 1-32
CS	Number of control bits per conversion sample	0-3
CF	Number of control words per frame clock period per link	0-32
HD	High Density user data format	0 or 1
LMFC	Local multiframe clock	$(F \times K / 4)$ link clock counts <sup>(1)</sup>

<sup>(1)</sup> The value of  $F \times K$  must be divisible by 4.



## 2.5.1. Run-Time Configuration

The JESD204B IP allows run-time configuration of LMF parameters in all supported devices except for Intel Stratix 10. For Intel Stratix 10 devices, the JESD204B IP core must be parameterized according to your target converter device with the IP configurations shown in *JESD204B Configurations Tab* of [Table 15](#) on page 36

**Note:** For Intel Stratix 10 devices, run-time access for certain registers have been disabled. Refer to the TX and RX register map for more information.

The most critical parameters that must be set correctly during IP generation are the  $L$  and  $F$  parameters. Parameter  $L$  denotes the maximum lanes supported while parameter  $F$  denotes the size of the deskew buffer needed for deterministic latency. The hardware generates during parameterization, which means that run-time programmability can only fall back from the parameterized and generated hardware, but not beyond the parameterized IP core.

You can use run-time configuration for prototyping or evaluating the performance of converter devices with various LMF configurations. However, in actual production, Intel recommends that you generate the JESD204B IP core with the intended LMF to get an optimized gate count.

For example, if a converter device supports  $LMF = 442$  and  $LMF = 222$ , to check the performance for both configurations, you need to generate the JESD204B IP with maximum  $F$  and  $L$ , which is  $L = 4$  and  $F = 2$ . During operation, you can use the fall back configuration to disable the lanes that are not used in  $LMF = 222$  mode. You must ensure that other JESD204B configurations like  $M$ ,  $N$ ,  $S$ ,  $CS$ ,  $CF$ , and  $HD$  do not violate the parameter  $F$  setting. You can access the Configuration and Status Register (CSR) space to modify other configurations such as:

- $K$  (multiframe)
- device and lane IDs
- enable or disable scrambler
- enable or disable character replacement

### F Parameter

This parameter indicates how many octets per frame per lane that the JESD204B link is operating in.

- Intel Agilex and Intel Stratix 10 (L-tile, H-tile, and E-tile) devices support  $F = 1-256$  ( $F = 3$  available)
- Intel Cyclone 10 GX, Intel Arria 10, Stratix V, Arria V, Arria V GZ, and Cyclone V devices support  $F = 1, 2, 4-256$  ( $F = 3$  not available)

To support the High Density (HD) data format, the JESD204B IP tracks the start of frame and end of frame because  $F$  can be either an odd or even number. The start of frame and start of multiframe wrap around the 32-bit data width architecture. The RX IP outputs the start of frame (`sof[3:0]`) and start of multiframe (`somf[3:0]`), which act as markers, using the Avalon-ST data stream. Based on these markers, the transport layer build the frames.

In a simpler system where the HD data format is set to 0, the  $F$  will always be 1, 2, 4, 6, 8, and so forth. This simplifies the transport layer design, so you do not need to use the `sof[3:0]` and `somf[3:0]` markers.

**Related Information**

- [Transmitter Registers](#) on page 99
- [Receiver Registers](#) on page 123

**2.6. Channel Bonding**

The JESD204B IP supports channel bonding—bonded (PMA bonding for Intel Agilex, Intel Stratix 10, Intel Arria 10, and Intel Cyclone 10 GX) and non-bonded modes.

The channel bonding mode that you select may contribute to the transmitter channel-to-channel skew. A bonded transmitter datapath clocking provides low channel-to-channel skew as compared to non-bonded channel configurations.

For Intel Stratix 10 L-tile and H-tile, Intel Arria 10, and Intel Cyclone 10 GX devices, refer to PMA Bonding chapter of the respective *Transceiver PHY User Guides*, about how to connect the ATX PLL and fPLL in bonded configuration and non-bonded configuration. For the non-bonded configuration, refer to *Implementing Multi-Channel xN Non-Bonded Configuration*. For bonded configuration, refer to *Implementing x6/xN Bonding Mode*.

- In PHY-only mode, you can generate up to 32 channels, provided that the channels are on the same side. In MAC and PHY integrated mode, you can generate up to 8 channels.
  - Note:* The maximum channels of 32 is for configuration simplicity. Refer to the *Intel FPGA Transceiver PHY User Guide* for the actual number of channels supported.
- In bonded channel configuration, the lower transceiver clock skew for all channels result in a lower channel-to-channel skew.
  - For Stratix V, Arria V, and Cyclone V devices, you must use contiguous channels when you select bonded mode. The JESD204B IP automatically selects between x6, xN or feedback compensation (fb\_compensation) bonding depending on the number of transceiver channels you set.
  - For Intel Arria 10, Intel Cyclone 10 GX, and Intel Stratix 10 L-tile and H-tile devices, you do not have to place the channels in bonded group contiguously. Refer to [Table 7](#) on page 13 for the clock network selection. Refer to *Channel Bonding* section of the respective *Transceiver PHY User Guides* for more information about PMA Bonding.
  - For Intel Agilex and Intel Stratix 10 E-tile devices, you must use contiguous channels to enable channel bonding with NRZ PMA transceiver channels.
- In non-bonded channel configuration, the transceiver clock skew is higher and latency is unequal in the transmitter phase compensation FIFO for each channel. This may result in a higher channel-to-channel skew.

**Table 6. Maximum Number of Lanes (L) Supported in Bonded and Non-Bonded Mode**

Device Family	Core Variation	Bonding Mode Configuration	Maximum Number of Lanes (L)
Intel Agilex Intel Stratix 10 Intel Arria 10 Intel Cyclone 10 GX	PHY only	Bonded	32 <sup>(2)</sup>
		Non-bonded	32 <sup>(2)</sup>
	MAC and PHY	Bonded	8
<i>continued...</i>			



Device Family	Core Variation	Bonding Mode Configuration	Maximum Number of Lanes (L)
Stratix V Arria V GZ Cyclone V		Non-bonded	8
Arria V	PHY only	Bonded	32 <sup>(2)</sup>
		Non-bonded	32 <sup>(2)</sup>
	MAC and PHY	Bonded	6
		Non-bonded	8

**Table 7. Clock Network Selection for Bonded Mode**

Note: The clock network selection is not applicable for Intel Stratix 10 E-tile devices.

Device Family	$L \leq 6$	$L > 6$
Intel Stratix 10 L-tile and H-tile Intel Arria 10 Intel Cyclone 10 GX	$\times 6$	$\times N$ <sup>(3)</sup>
Stratix V	$\times 6$	Feedback compensation
Arria V	$\times N$	$\times N$
Arria V GZ	$\times 6$	Feedback compensation
Cyclone V	$\times N$	$\times N$

#### Related Information

- [V-Series Transceiver PHY User Guide](#)
- [Intel Arria 10 Transceiver PHY User Guide](#)
- [Intel Cyclone 10 GX Transceiver PHY User Guide](#)
- [Intel Stratix 10 L- and H-tile Transceiver PHY User Guide](#)
- [E-tile Transceiver PHY User Guide](#)
- [Intel Agilex Device Datasheet](#)
- [Intel Stratix 10 Device Datasheet](#)
- [Intel Arria 10 Device Datasheet](#)

<sup>(2)</sup> The maximum lanes listed here is for configuration simplicity. Refer to the *Intel FPGA Transceiver PHY User Guides* for the actual number of channels supported.

<sup>(3)</sup> Bonded mode is not supported for data rate > 15 Gbps. Refer to the respective datasheet for the maximum data rate and channel span supported by the  $\times N$  clock network and the transceiver power supply operating condition for your device.



## 2.7. Performance and Resource Utilization

**Table 8. JESD204B Intel FPGA IP Performance**

Device Family	PMA Speed Grade	FPGA Fabric Speed Grade	Data Rate		Link Clock F <sub>MAX</sub> (MHz)
			Enable Hard PCS (Gbps)	Enable Soft PCS (Gbps) <sup>(4)</sup>	
Intel Agilex (E-tile)	1	-1	Not supported	2.0 to 19.2	data_rate/40
	2	-2	Not supported	2.0 to 17.4	data_rate/40
	3	-2	Not supported	2.0 to 17.4	data_rate/40
		-3	Not supported	2.0 to 16.0	data_rate/40
Intel Stratix 10 (L-tile, and H-tile)	1	-1	2.0 to 12.0	2.0 to 16.0 <sup>(6)</sup>	data_rate/40
		-2	2.0 to 12.0	2.0 to 14.0	data_rate/40
	2	-1	2.0 to 9.83	2.0 to 16.0 <sup>(6)</sup>	data_rate/40
		-2	2.0 to 9.83	2.0 to 14.0	data_rate/40
	3	-1	2.0 to 9.83	2.0 to 16.0 <sup>(6)</sup>	data_rate/40
		-2	2.0 to 9.83	2.0 to 14.0	data_rate/40
		-3	2.0 to 9.83	2.0 to 13.0	data_rate/40
Intel Stratix 10 (E-tile)	1	-1	Not supported	2.0 to 16.0 <sup>(6)</sup>	data_rate/40
		-2	Not supported	2.0 to 14.0	data_rate/40
	2	-1	Not supported	2.0 to 16.0 <sup>(6)</sup>	data_rate/40
		-2	Not supported	2.0 to 14.0	data_rate/40
	3	-3	Not supported	2.0 to 13.0	data_rate/40
Intel Arria 10	1	-1	2.0 to 12.0	2.0 to 15.0 <sup>(6)(5)</sup>	data rate/40

**continued...**

<sup>(4)</sup> Select *Enable Soft PCS* to achieve maximum data rate. For the TX IP core, enabling soft PCS incurs an additional 3–8% increase in resource utilization. For the RX IP core, enabling soft PCS incurs an additional 10–20% increase in resource utilization.

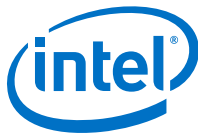
<sup>(5)</sup> When using Soft PCS mode at 15.0 Gbps, the timing margin is very limited. You are advised to enable high fitter effort, register duplication, and register retiming to improve timing performance.



Device Family	PMA Speed Grade	FPGA Fabric Speed Grade	Data Rate		Link Clock F <sub>MAX</sub> (MHz)
			Enable Hard PCS (Gbps)	Enable Soft PCS (Gbps) <sup>(4)</sup>	
	2	-1	2.0 to 12.0	2.0 to 15.0 <sup>(6)</sup> <sup>(5)</sup>	data rate/40
	2	-2	2.0 to 9.83	2.0 to 15.0 <sup>(6)</sup> <sup>(5)</sup>	data rate/40
	3	-1	2.0 to 12.0	2.0 to 14.2 <sup>(6)</sup> <sup>(7)</sup>	data rate/40
	3	-2	2.0 to 9.83	2.0 to 14.2 <sup>(6)</sup> <sup>(8)</sup>	data rate/40
	4	-3	2.0 to 8.83	2.0 to 12.5 <sup>(9)</sup>	data rate/40
Intel Cyclone 10 GX	<Any supported speed grade>	<Any supported speed grade>	2.0 to 6.25	2.0 to 6.25	data rate/40
Stratix V	1	-1 or -2	2.0 to 12.2	2.0 to 12.5	data rate/40
	2	-1 or -2	2.0 to 12.2	2.0 to 12.5	data rate/40
	2	-3	2.0 to 9.8	2.0 to 12.5 <sup>(10)</sup>	data rate/40
	3	-1, -2, -3, or -4	2.0 to 8.5	2.0 to 8.5	data rate/40
Arria V GX/SX	<Any supported speed grade>	<Any supported speed grade>	1.0 to 6.55	— <sup>(11)</sup>	data rate/40
Arria V GT/ST	<Any supported speed grade>	<Any supported speed grade>	1.0 to 6.55	4.0 to 7.5 (PMA direct) <sup>(11)</sup>	data rate/40

continued...

- <sup>(4)</sup> Select `Enable Soft PCS` to achieve maximum data rate. For the TX IP core, enabling soft PCS incurs an additional 3–8% increase in resource utilization. For the RX IP core, enabling soft PCS incurs an additional 10–20% increase in resource utilization.
- <sup>(6)</sup> Refer to the Intel Arria 10 and Intel Stratix 10 Device Datasheet for the maximum data rate supported across transceiver speed grades and transceiver power supply operating conditions.
- <sup>(7)</sup> For Intel Arria 10 GX 160, SX 160, GX 220 and SX 220 devices, the supported data rate is up to 12.288 Gbps.
- <sup>(8)</sup> For Intel Arria 10 GX 160, SX 160, GX 220 and SX 220 devices, the supported data rate is 11.0 Gbps.
- <sup>(9)</sup> For Intel Arria 10 GX 160, SX 160, GX 220 and SX 220 devices, the supported data rate is 10.0 Gbps.
- <sup>(10)</sup> When using Soft PCS mode at 12.5 Gbps, the timing margin is very limited. You are advised to enable high fitter effort, register duplication, and register retiming to improve timing performance.
- <sup>(11)</sup> Enabling Soft PCS does not increase the data rate for the device family and speed grade. You are recommended to select the `Enable Hard PCS` option.



Device Family	PMA Speed Grade	FPGA Fabric Speed Grade	Data Rate		Link Clock F <sub>MAX</sub> (MHz)
			Enable Hard PCS (Gbps)	Enable Soft PCS (Gbps) <sup>(4)</sup>	
Arria V GZ	2	-3	2.0 to 9.9	— <sup>(11)</sup>	data rate/40
	3	-4	2.0 to 8.8	— <sup>(11)</sup>	data rate/40
Cyclone V	5	<Any supported speed grade>	1.0 to 5.0	—	data rate/40
	6	-6 or -7	1.0 to 3.125	—	data rate/40

The following table lists the resources and expected performance of the JESD204B IP core. These results are obtained using the Intel Quartus Prime software targeting the following Intel FPGA devices:

- Cyclone V: 5CGTFD9E5F31I7
- Arria V GT/S/GT: 5AGXFB3H4F35C5
- Arria V GZ: 5AGZME5K2F40C3
- Stratix V: 5SGXEA7H3F35C3
- Intel Arria 10: 10AX115H2F34I2SGES
- Intel Stratix 10: 1SG280LN3F43E3VG
- Intel Cyclone 10 GX: 10CX105YF672I6G

All the variations for resource utilization are configured with the following parameter settings:

**Table 9. Parameter Settings To Obtain the Resource Utilization Data**

Parameter	Setting
JESD204B Wrapper	Base and PHY
JESD204B Subclass	1
Data Rate	5 Gbps
PCS Option	Enabled Hard PCS
PLL Type	<ul style="list-style-type: none"> <li>• ATX (for Intel Arria 10, Intel Cyclone 10 GX, and Intel Stratix 10 L-tile and H-tile devices)</li> <li>• CMU (for Arria V, Cyclone V, and Stratix V devices)</li> </ul>
Bonding Mode	Non-bonded
Reference Clock Frequency	125.0 MHz
<i>continued...</i>	

<sup>(4)</sup> Select `Enable Soft PCS` to achieve maximum data rate. For the TX IP core, enabling soft PCS incurs an additional 3–8% increase in resource utilization. For the RX IP core, enabling soft PCS incurs an additional 10–20% increase in resource utilization.





Parameter	Setting
Octets per frame (F)	<ul style="list-style-type: none"> <li>1 (For all devices, including Intel Stratix 10)</li> <li>3 (For Intel Stratix 10 device only)</li> </ul>
Enable Scrambler (SCR)	Off
Enable Error Code Correction (ECC_EN)	Off

**Table 10. JESD204B IP Core Resource Utilization**

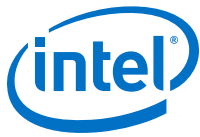
*Note:* The resource utilization data are extracted from a full design which includes the Intel FPGA Transceiver PHY Reset Controller IP core. Thus, the actual resource utilization for the JESD204B IP core should be smaller by about 15 ALMs and 20 registers.

Device Family	Data Path	Number of Lanes (L)	ALMs	ALUTs	Logic Registers	Memory Block (M10K/M20K) (12) (13)
Intel Stratix 10 (F=1)	RX	1	889.4	1230	1334	0
		2	1329.7	1810	2119	0
		4	2302.8	3101	3634	0
		8	4218.1	5638	6650	0
	TX	1	534.4	694	869	0
		2	746	1061	1078	0
		4	1049.8	1557	1580	0
		8	1534.2	1980	2507	0
Intel Stratix 10 (F=3)	RX	1	905.1	1336	1453	1
		2	1431.5	2102	2281	2
		4	2445.9	3487	3899	4
		8	4568	6592	6870	8
	TX	1	568.7	737	907	0
		2	790.2	1126	1126	0
		4	1096.4	1659	1545	0
		8	1617.1	2082	2524	0
Intel Arria 10	RX	1	1047	1496	1264	0
		2	1584	2262	1903	0
		4	2884.5	3870	3211	0
		8	5339	7196	5768	0
	TX	1	701.5	1090	989	0

*continued...*

(12) M10K for Arria V, Cyclone V devices, M20K for Arria V GZ, Stratix V, Intel Arria 10, Intel Cyclone 10 GX, and Intel Stratix 10 devices.

(13) The Intel Quartus Prime software may auto-fit to use MLAB when the memory size is too small. Conversion from MLAB to M20K or M10K was performed for the numbers listed above.



Device Family	Data Path	Number of Lanes (L)	ALMs	ALUTs	Logic Registers	Memory Block (M10K/M20K) ( <sup>12</sup> ) ( <sup>13</sup> )
		2	875.5	1341	1126	0
		4	1248.5	1888	1382	0
		8	1917.5	2820	1878	0
Intel Cyclone 10 GX	RX	1	1020.5	1496	1250	1
		2	1551.5	2262	1877	2
		4	2801	3870	3159	4
		8	5173.5	7196	5749	8
	TX	1	710	1090	989	0
		2	875.4	1341	1118	0
		4	1249	1888	1369	0
		8	1926.5	2820	1869	0
Stratix V	RX	1	1047.2	1530	1225	0
		2	1608.7	2322	1871	0
		4	2897.2	4037	3161	0
		8	5412.5	7506	5742	0
	TX	1	711	1152	948	0
		2	926.7	1491	1086	0
		4	1345.7	2134	1361	0
		8	2114.7	3358	1907	0
Arria V	RX	1	1024.5	1516	1207	1
		2	1555.5	2302	1838	2
		4	2769.5	3951	3102	4
		8	5189	7399	5619	8
	TX	1	711.7	1149	948	0
		2	860.5	1418	1065	0
		4	1188.7	1932	1299	0
		8	1721	2854	1767	0
Arria V GZ	RX	1	1048.7	1530	1226	0
		2	1601.5	2322	1870	0
		4	2894	4037	3163	0

*continued...*

(12) M10K for Arria V, Cyclone V devices, M20K for Arria V GZ, Stratix V, Intel Arria 10, Intel Cyclone 10 GX, and Intel Stratix 10 devices.

(13) The Intel Quartus Prime software may auto-fit to use MLAB when the memory size is too small. Conversion from MLAB to M20K or M10K was performed for the numbers listed above.



Device Family	Data Path	Number of Lanes (L)	ALMs	ALUTs	Logic Registers	Memory Block (M10K/M20K) (12) (13)
	TX	8	5400.5	7506	5748	0
		1	712.2	1152	948	0
		2	926.5	1491	1087	0
		4	1349.2	2134	1359	0
		8	2104.7	3358	1907	0
Cyclone V	RX	1	1022	1516	1210	1
		2	1555.5	2302	1839	2
		4	2777.5	3951	3099	4
		8	5195	7399	5619	8
	TX	1	713.5	1149	948	0
		2	867	1418	1066	0
		4	1198	1932	1300	0
		8	1709.2	2838	1769	0

**Related Information**

JESD204B Intel FPGA IP Parameters on page 36

(12) M10K for Arria V, Cyclone V devices, M20K for Arria V GZ, Stratix V, Intel Arria 10, Intel Cyclone 10 GX, and Intel Stratix 10 devices.

(13) The Intel Quartus Prime software may auto-fit to use MLAB when the memory size is too small. Conversion from MLAB to M20K or M10K was performed for the numbers listed above.



## 3. Getting Started

---

### Related Information

- [Intel FPGA Software Installation & Licensing](#)
- [Introduction to Intel FPGA IP Cores](#)  
Provides general information about all Intel FPGA IP cores, including parameterizing, generating, upgrading, and simulating IP cores.
- [Creating Version-Independent IP and Platform Designer Simulation Scripts](#)  
Create simulation scripts that do not require manual updates for software or IP version upgrades.
- [Project Management Best Practices](#)  
Guidelines for efficient management and portability of your project and IP files.

### 3.1. Introduction to Intel FPGA IP Cores

Intel and strategic IP partners offer a broad portfolio of configurable IP cores optimized for Intel FPGA devices.

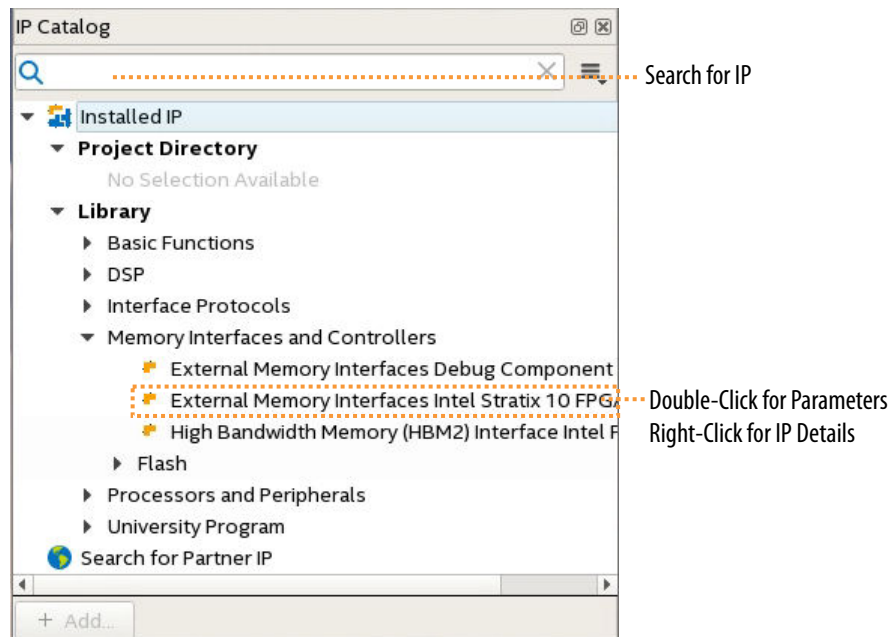
The Intel Quartus Prime software installation includes the Intel FPGA IP library. Integrate optimized and verified Intel FPGA IP cores into your design to shorten design cycles and maximize performance. The Intel Quartus Prime software also supports integration of IP cores from other sources. Use the IP Catalog (**Tools > IP Catalog**) to efficiently parameterize and generate synthesis and simulation files for your custom IP variation. The Intel FPGA IP library includes the following types of IP cores:

- Basic functions
- DSP functions
- Interface protocols
- Low power functions
- Memory interfaces and controllers
- Processors and peripherals

This document provides basic information about parameterizing, generating, upgrading, and simulating stand-alone IP cores in the Intel Quartus Prime software.



Figure 2. IP Catalog



### 3.2. Installing and Licensing Intel FPGA IP Cores

The Intel Quartus Prime software installation includes the Intel FPGA IP library. This library provides many useful IP cores for your production use without the need for an additional license. Some Intel FPGA IP cores require purchase of a separate license for production use. The Intel FPGA IP Evaluation Mode allows you to evaluate these licensed Intel FPGA IP cores in simulation and hardware, before deciding to purchase a full production IP core license. You only need to purchase a full production license for licensed Intel IP cores after you complete hardware testing and are ready to use the IP in production.

The Intel Quartus Prime software installs IP cores in the following locations by default:

Figure 3. IP Core Installation Path

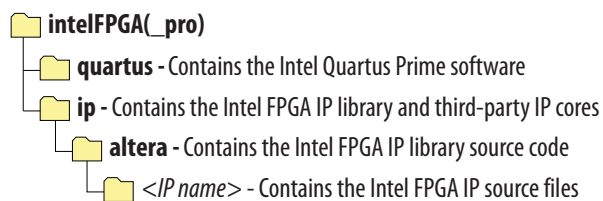




Table 11. IP Core Installation Locations

Location	Software	Platform
<drive>:\intelFPGA_pro\quartus\ip\altera	Intel Quartus Prime Pro Edition	Windows*
<drive>:\intelFPGA\quartus\ip\altera	Intel Quartus Prime Standard Edition	Windows
<home directory>:/intelFPGA_pro/quartus/ip/altera	Intel Quartus Prime Pro Edition	Linux*
<home directory>:/intelFPGA/quartus/ip/altera	Intel Quartus Prime Standard Edition	Linux

Note: The Intel Quartus Prime software does not support spaces in the installation path.

### 3.3. Intel FPGA IP Evaluation Mode

The free Intel FPGA IP Evaluation Mode allows you to evaluate licensed Intel FPGA IP cores in simulation and hardware before purchase. Intel FPGA IP Evaluation Mode supports the following evaluations without additional license:

- Simulate the behavior of a licensed Intel FPGA IP core in your system.
- Verify the functionality, size, and speed of the IP core quickly and easily.
- Generate time-limited device programming files for designs that include IP cores.
- Program a device with your IP core and verify your design in hardware.

Intel FPGA IP Evaluation Mode supports the following operation modes:

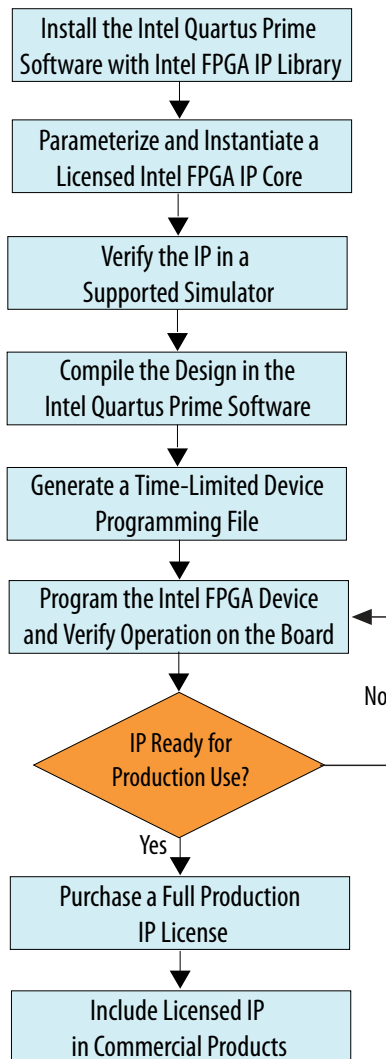
- **Tethered**—Allows running the design containing the licensed Intel FPGA IP indefinitely with a connection between your board and the host computer. Tethered mode requires a serial joint test action group (JTAG) cable connected between the JTAG port on your board and the host computer, which is running the Intel Quartus Prime Programmer for the duration of the hardware evaluation period. The Programmer only requires a minimum installation of the Intel Quartus Prime software, and requires no Intel Quartus Prime license. The host computer controls the evaluation time by sending a periodic signal to the device via the JTAG port. If all licensed IP cores in the design support tethered mode, the evaluation time runs until any IP core evaluation expires. If all of the IP cores support unlimited evaluation time, the device does not time-out.
- **Untethered**—Allows running the design containing the licensed IP for a limited time. The IP core reverts to untethered mode if the device disconnects from the host computer running the Intel Quartus Prime software. The IP core also reverts to untethered mode if any other licensed IP core in the design does not support tethered mode.

When the evaluation time expires for any licensed Intel FPGA IP in the design, the design stops functioning. All IP cores that use the Intel FPGA IP Evaluation Mode time out simultaneously when any IP core in the design times out. When the evaluation time expires, you must reprogram the FPGA device before continuing hardware verification. To extend use of the IP core for production, purchase a full production license for the IP core.

You must purchase the license and generate a full production license key before you can generate an unrestricted device programming file. During Intel FPGA IP Evaluation Mode, the Compiler only generates a time-limited device programming file (<project name>\_time\_limited.sof) that expires at the time limit.



Figure 4. Intel FPGA IP Evaluation Mode Flow



**Note:** Refer to each IP core's user guide for parameterization steps and implementation details.

Intel licenses IP cores on a per-seat, perpetual basis. The license fee includes first-year maintenance and support. You must renew the maintenance contract to receive updates, bug fixes, and technical support beyond the first year. You must purchase a full production license for Intel FPGA IP cores that require a production license, before generating programming files that you may use for an unlimited time. During Intel FPGA IP Evaluation Mode, the Compiler only generates a time-limited device programming file (*<project name>\_time\_limited.sof*) that expires at the time limit. To obtain your production license keys, visit the [Self-Service Licensing Center](#).

The [Intel FPGA Software License Agreements](#) govern the installation and use of licensed IP cores, the Intel Quartus Prime design software, and all unlicensed IP cores.

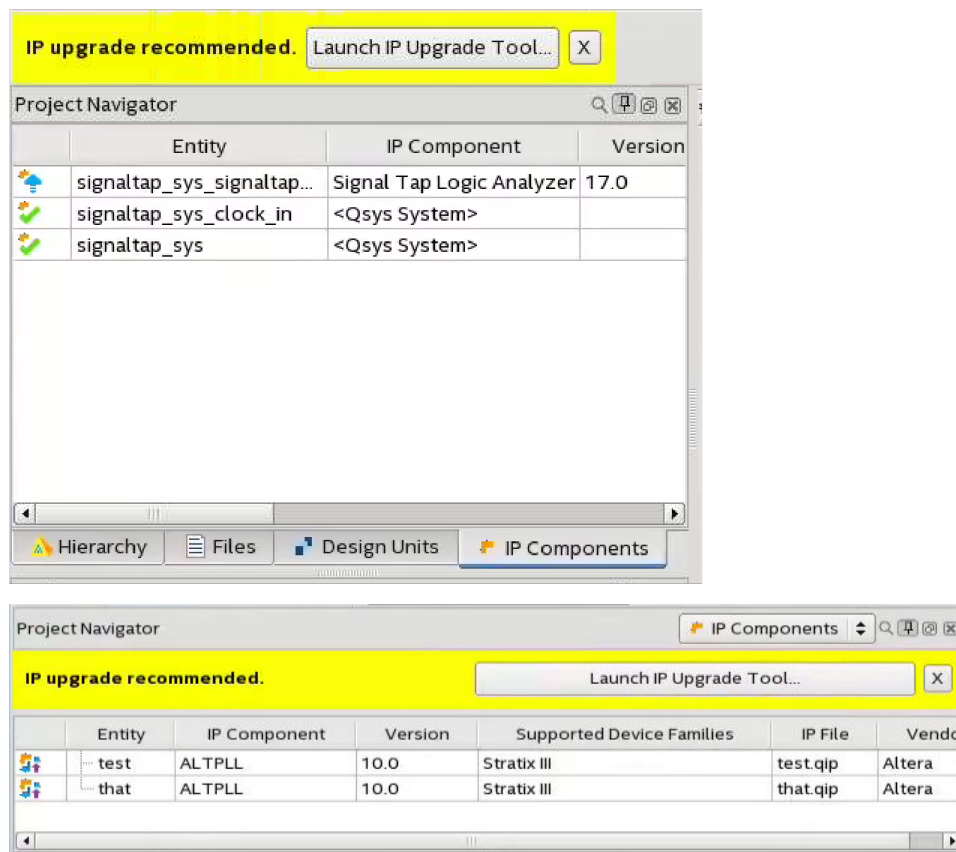
### Related Information

- [Intel Quartus Prime Licensing Site](#)
- [Introduction to Intel FPGA Software Installation and Licensing](#)

## 3.4. Upgrading IP Cores

Any Intel FPGA IP variations that you generate from a previous version or different edition of the Intel Quartus Prime software, may require upgrade before compilation in the current software edition or version. The Project Navigator displays a banner indicating the IP upgrade status. Click **Launch IP Upgrade Tool** or **Project > Upgrade IP Components** to upgrade outdated IP cores.

Figure 5. IP Upgrade Alert in Project Navigator











Icons in the **Upgrade IP Components** dialog box indicate when IP upgrade is required, optional, or unsupported for an IP variation in the project. Upgrade IP variations that require upgrade before compilation in the current version of the Intel Quartus Prime software.






**Note:** Upgrading IP cores may append a unique identifier to the original IP core entity names, without similarly modifying the IP instance name. There is no requirement to update these entity references in any supporting Intel Quartus Prime file, such as the Intel Quartus Prime Settings File (.qsf), Synopsys\* Design Constraints File (.sdc), or Signal Tap File (.stp), if these files contain instance names. The Intel Quartus Prime software reads only the instance name and ignores the entity name in paths that specify both names. Use only instance names in assignments.

**Table 12. IP Core Upgrade Status**

IP Core Status	Description
IP Upgraded 	Indicates that your IP variation uses the latest version of the Intel FPGA IP core.
IP Component Outdated 	Indicates that your IP variation uses an outdated version of the IP core.
IP Upgrade Optional 	Indicates that upgrade is optional for this IP variation in the current version of the Intel Quartus Prime software. You can upgrade this IP variation to take advantage of the latest development of this IP core. Alternatively, you can retain previous IP core characteristics by declining to upgrade. Refer to the Description for details about IP core version differences. If you do not upgrade the IP, the IP variation synthesis and simulation files are unchanged and you cannot modify parameters until upgrading.
IP Upgrade Required 	Indicates that you must upgrade the IP variation before compiling in the current version of the Intel Quartus Prime software. Refer to the Description for details about IP core version differences.
IP Upgrade Unsupported 	Indicates that upgrade of the IP variation is not supported in the current version of the Intel Quartus Prime software due to incompatibility with the current version of the Intel Quartus Prime software. The Intel Quartus Prime software prompts you to replace the unsupported IP core with a supported equivalent IP core from the IP Catalog. Refer to the Description for details about IP core version differences and links to Release Notes.
IP End of Life 	Indicates that Intel designates the IP core as end-of-life status. You may or may not be able to edit the IP core in the parameter editor. Support for this IP core discontinues in future releases of the Intel Quartus Prime software.
IP Upgrade Mismatch Warning 	Provides warning of non-critical IP core differences in migrating IP to another device family.
IP has incompatible subcores 	Indicates that the current version of the Intel Quartus Prime software does not support compilation of your IP variation, because the IP has incompatible subcores

*continued...*

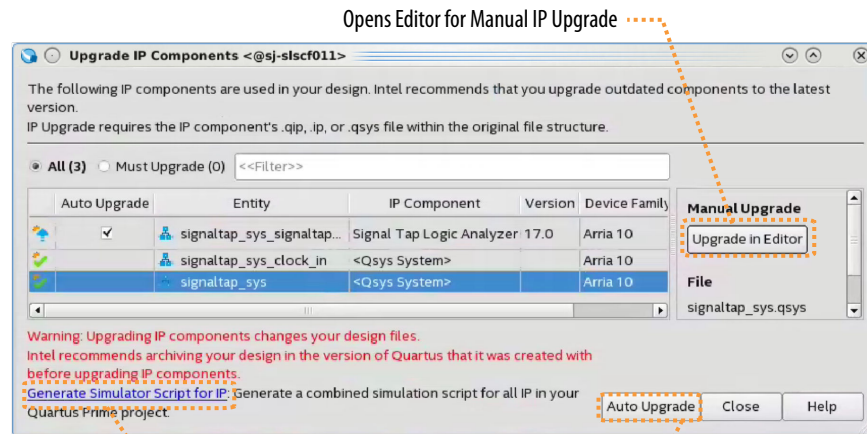
IP Core Status	Description
Compilation of IP Not Supported  	Indicates that the current version of the Intel Quartus Prime software does not support compilation of your IP variation. This can occur if another edition of the Intel Quartus Prime software, such as the Intel Quartus Prime Standard Edition, generated this IP. Replace this IP component with a compatible component in the current edition.

Follow these steps to upgrade IP cores:

1. In the latest version of the Intel Quartus Prime software, open the Intel Quartus Prime project containing an outdated IP core variation. The **Upgrade IP Components** dialog box automatically displays the status of IP cores in your project, along with instructions for upgrading each core. To access this dialog box manually, click **Project > Upgrade IP Components**.
2. To upgrade one or more IP cores that support automatic upgrade, ensure that you turn on the **Auto Upgrade** option for the IP cores, and click **Auto Upgrade**. The **Status** and **Version** columns update when upgrade is complete. Example designs that any Intel FPGA IP core provides regenerate automatically whenever you upgrade an IP core.
3. To manually upgrade an individual IP core, select the IP core and click **Upgrade in Editor** (or simply double-click the IP core name). The parameter editor opens, allowing you to adjust parameters and regenerate the latest version of the IP core.

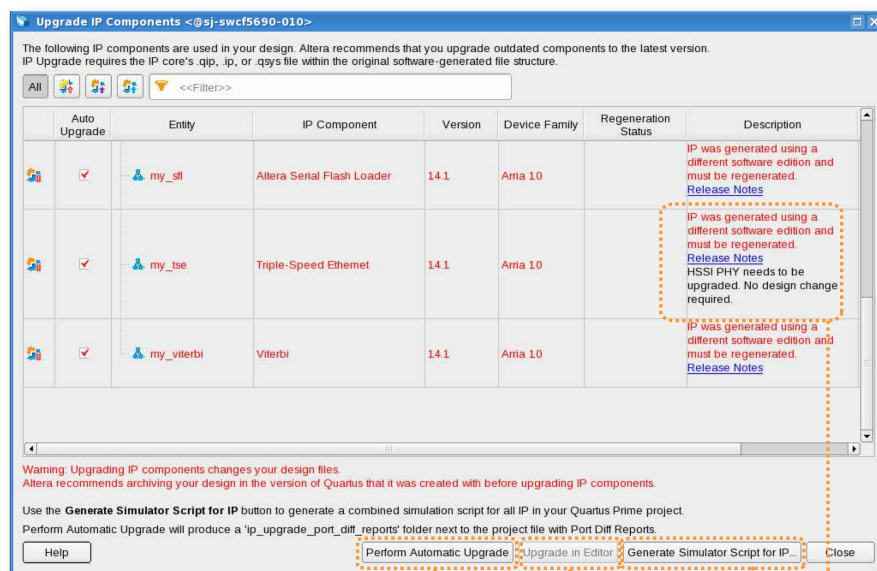


Figure 6. Upgrading IP Cores



Runs "Auto Upgrade" on all Outdated Cores

Generates/Updates Combined Simulation Setup Script for all Project IP



Runs "Auto Upgrade" on all Outdated Cores

Opens Editor for Manual IP Upgrade

Generates/Updates Combined Simulation Setup Script for all Project IP

Upgrade Details

**Note:** Intel FPGA IP cores older than Intel Quartus Prime software version 12.0 do not support upgrade. Intel verifies that the current version of the Intel Quartus Prime software compiles the previous two versions of each IP core. The *Intel FPGA IP Core Release Notes* reports any verification exceptions for Intel FPGA IP cores. Intel does not verify compilation for IP cores older than the previous two releases.

### Related Information

[Intel FPGA IP Release Notes](#)

## 3.5. IP Catalog and Parameter Editor

The IP Catalog displays the IP cores available for your project, including Intel FPGA IP and other IP that you add to the IP Catalog search path. Use the following features of the IP Catalog to locate and customize an IP core:

- Filter IP Catalog to **Show IP for active device family** or **Show IP for all device families**. If you have no project open, select the **Device Family** in IP Catalog.
- Type in the Search field to locate any full or partial IP core name in IP Catalog.
- Right-click an IP core name in IP Catalog to display details about supported devices, to open the IP core's installation folder, and for links to IP documentation.
- Click **Search for Partner IP** to access partner IP information on the web.

The parameter editor prompts you to specify an IP variation name, optional ports, and output file generation options. The parameter editor generates a top-level Intel Quartus Prime IP file (.ip) for an IP variation in Intel Quartus Prime Pro Edition projects or Quartus IP file (.qip) for an IP variation in Intel Quartus Prime Standard Edition projects.

## 3.6. Design Walkthrough

This walkthrough explains how to create a JESD204B IP core design using Platform Designer in the Intel Quartus Prime software. After you generate a custom variation of the JESD204B IP core, you can incorporate it into your overall project.

### 3.6.1. Creating a New Intel Quartus Prime Project

You can create a new Intel Quartus Prime project with the **New Project Wizard**. Creating a new project allows you to do the following:

- Specify the working directory for the project.
  - Assign the project name.
  - Designate the name of the top-level design entity.
1. Launch the Intel Quartus Prime software.
  2. On the **File** menu, click **New Project Wizard**.
  3. In the **New Project Wizard: Directory, Name, Top-Level Entity** page, specify the working directory, project name, and top-level design entity name. Click **Next**.
  4. In the **New Project Wizard: Add Files** page, select the existing design files (if any) you want to include in the project.<sup>(14)</sup> Click **Next**.

---

<sup>(14)</sup> To include existing files, you must specify the directory path to where you installed the JESD204B IP core. You must also add the user libraries if you installed the IP core Library in a different directory from where you installed the Intel Quartus Prime software.



5. In the **New Project Wizard: Family & Device Settings** page, select the device family and specific device you want to target for compilation. Click **Next**.
6. In the **EDA Tool Settings** page, select the EDA tools you want to use with the Intel Quartus Prime software to develop your project.
7. Review the summary of your chosen settings in the **New Project Wizard** window, then click **Finish** to complete the Intel Quartus Prime project creation.

### 3.6.2. Parameterizing and Generating the IP

Refer to [Table 15](#) on page 36 for the IP core parameter values and description.

1. In the IP Catalog (**Tools > IP Catalog**), locate and double-click the JESD204B Intel FPGA IP.
2. Specify a top-level name for your custom IP variation. This name identifies the IP core variation files in your project. If prompted, also specify the target Intel FPGA device family and output file HDL preference. Click **OK**.
3. In the Main tab, set the following options:
  - **Jesd204b wrapper**
  - **Data path**
  - **Jesd204b subclass**
  - **Data Rate**
  - **Transceiver Tile**
  - **PCS Option**
  - **PLL Type**
  - **Bonding Mode**
  - **PLL/CDR Reference Clock Frequency**
  - **Enable Bit reversal and Byte reversal**
  - **Enable Transceiver Dynamic Reconfiguration**
  - **Enable Native PHY Debug Master Endpoint**
  - **Enable Capability Registers**
  - **Set user-defined IP identifier**
  - **Enable Control and Status Registers**
  - **Enable PRBS Soft Accumulators**
4. In the Jesd204b Configurations tab, select the following configurations:
  - **Common configurations (L, M, Enable manual F configuration, F, N, N', S, K)**
  - **Advanced configurations (SCR, CS, CF, HD, ECC\_EN, PHADJ, ADJCNT, ADJDIR)**
5. In the Configurations and Status Registers tab, set the following configurations:
  - **Device ID**
  - **Bank ID**
  - **Lane ID**
  - **Lane checksum**

6. After parameterizing the core, go to the Example Design tab and click **Generate Example Design** to create the simulation testbench. Skip to 8 if you do not want to generate the design example.
7. Set a name for your `<example_design_directory>` and click **OK** to generate supporting files and scripts.  
The testbench and scripts are located in the `<example_design_directory>/ip_sim` folder.

The **Generate Example Design** option generates supporting files for the following entities:

- IP core for simulation—refer to [Generating and Simulating the IP Testbench](#) on page 42
  - IP core design example for simulation—refer to *Generating and Simulating the Design Example* section in the respective design example user guides.
  - IP core design example for synthesis—refer to *Compiling the JESD204B IP Core Design Example* section in the respective design example user guides.
8. Click **Finish** or **Generate HDL** to generate synthesis and other optional files matching your IP variation specifications. The parameter editor generates the top-level `.ip`, `.qip` or `.qsys` IP variation file and HDL files for synthesis and simulation.

The top-level IP variation is added to the current Intel Quartus Prime project. Click **Project ► Add/Remove Files in Project** to manually add a `.qip` or `.qsys` file to a project. Make appropriate pin assignments to connect ports.

*Note:* Some parameter options are grayed out if they are not supported in a selected configuration or it is a derived parameter.

#### Related Information

- [Design Examples for JESD204B IP Core User Guide](#)  
Provides information about design examples for Arria V, Cyclone V, Stratix V, and Intel Arria 10 devices using Intel Quartus Prime Standard Edition software.
- [JESD204B Intel Arria 10 FPGA IP Design Example User Guide](#)
- [JESD204B Intel Stratix 10 FPGA IP Design Example User Guide](#)
- [JESD204B Intel Cyclone 10 GX FPGA IP Design Example User Guide](#)
- [JESD204B Intel Agilex FPGA IP Design Example User Guide](#)

### 3.6.3. Compiling the JESD204B IP Core Design

Refer to the [JESD204B IP Design Considerations](#) on page 31 before compiling the JESD204B IP core design.

To compile your design, click **Start Compilation** on the Processing menu in the Intel Quartus Prime software. You can use the generated `.ip` or `.qip` file to include relevant files into your project.

#### Related Information

- [JESD204B IP Design Considerations](#) on page 31
- [Intel Quartus Prime Help](#)  
More information about compilation in Intel Quartus Prime software.



### 3.6.4. Programming an FPGA Device

After successfully compiling your design, program the targeted Intel device with the Intel Quartus Prime Programmer and verify the design in hardware. For instructions on programming the FPGA device, refer to the *Device Programming* section in the Intel Quartus Prime Handbook.

#### Related Information

[Device Programming](#)

### 3.7. JESD204B Design Examples

The JESD204B IP offers design examples that you can generate through the IP catalog in the Intel Quartus Prime software.

For detailed information about the JESD204B design examples, refer to following user guides:

#### Related Information

- [Design Examples for JESD204B IP Core User Guide](#)  
Provides information about design examples for Arria V, Cyclone V, Stratix V, and Intel Arria 10 devices using Intel Quartus Prime Standard Edition software.
- [JESD204B Intel Arria 10 FPGA IP Design Example User Guide](#)
- [JESD204B Intel Stratix 10 FPGA IP Design Example User Guide](#)
- [JESD204B Intel Cyclone 10 GX FPGA IP Design Example User Guide](#)
- [JESD204B Intel Agilex FPGA IP Design Example User Guide](#)

### 3.8. JESD204B IP Design Considerations

You must be aware of the following conditions when integrating the JESD204B IP in your design:

- Integrating the IP in Platform Designer
- Pin assignments
- Adding external transceiver PLL
- Timing constraints for the input clock

#### 3.8.1. Integrating the JESD204B IP in Platform Designer

You can integrate the JESD204B IP with other Platform Designer components within Platform Designer.

You can connect standard interfaces like clock, reset, Avalon-MM, Avalon-ST, HSSI bonded clock, HSSI serial clock, and interrupt interfaces within Platform Designer. However, for conduit interfaces, you are advised to export all those interfaces and handle them outside of Platform Designer. <sup>(15)</sup> This is because conduit interfaces are not part of the standard interfaces. Thus, there is no guarantee on compatibility between different conduit interfaces.

**Note:** The Transport Layer provided in this JESD204B IP design example is not supported in Platform Designer. Therefore, you must export all interfaces that connect to the Transport Layer (for example, *jесd204\_tx\_link* interface) and connect them to a transport layer outside of Platform Designer.

### Figure 7. Example of Connecting JESD204B IP with Other Platform Designer Components in Platform Designer

Figure shows an example of how you connect the IP with other Platform Designer components in Platform Designer.

Use	Connections	Name	Description	Export	Clock	Base	End	IRQ	Auto Export
		<b>mgmt_clk</b>	Clock Source						
		clk_in	Clock Input	clk_reset	exported				
		clk_in_reset	Reset Input	reset	[clk_in]				
		clk	Clock Output	clk_reset	mgmt_clk				
		clk_reset	Reset Output	clk_reset	mgmt_clk				
		<b>link_clk</b>	Clock Source						
		clk_in	Clock Input	clk_0	exported				
		clk_in_reset	Reset Input	reset_0	[clk_in]				
		clk	Clock Output	reset_0	link_clk				
		clk_reset	Reset Output	reset_0	link_clk				
		<b>mm_master_bfm</b>	Altera Avalon-MM Master BFM						
		clk	Clock Input	clk	mgmt_clk				
		clk_reset	Reset Input	reset	[clk]				
		m0	Avalon Memory Mapped Master	m0	[clk]				
		<b>jесd_tx</b>	Jesd204b						
		txlink_clk	Clock Input	txlink_clk	link_clk				
		txlink_rst_0	Reset Input	reset_0	[txlink_clk]				
		Jesd204_tx_avs_clk	Clock Input	Jesd204_tx_avs_clk	mgmt_clk				
		Jesd204_tx_avs_rst_n	Reset Input	Jesd204_tx_avs_rst_n	[Jesd204_tx_avs_clk]				
		Jesd204_tx_avs	Avalon Memory Mapped Slave	Jesd204_tx_avs	[Jesd204_tx_avs_clk]	0x0000_0000	0x0000_03ff		
		Jesd204_tx_link	Avalon Streaming Sink	Jesd204_tx_link	[txlink_clk]				
		<b>atx_pll</b>	Arria 10 Transceiver ATX PLL						
		pll_powerdown	Conduit	atx_pll_pll_powerdown	mgmt_clk				
		pll_refclk0	Clock Input	atx_pll_pll_refclk0	mgmt_clk				
		pll_locked	Conduit	atx_pll_pll_locked	mgmt_clk				
		pll_cal_busy	Conduit	atx_pll_pll_cal_busy	mgmt_clk				
		mcqb_rst	Conduit	atx_pll_mcqb_rst	mgmt_clk				
		tx_bonding_clocks	HSSI Bonded Clock Output	tx_bonding_clocks	mgmt_clk				
		<b>phy_rst_ctrl</b>	Transceiver PHY Reset Controller						
		clock	Clock Input	clock	mgmt_clk				
		reset	Reset Input	reset	mgmt_clk				
		pll_powerdown	Conduit	phy_rst_ctrl_pll_powerdown	mgmt_clk				
		tx_analogreset	Conduit	phy_rst_ctrl_tx_analogreset	mgmt_clk				
		tx_digitalreset	Conduit	phy_rst_ctrl_tx_digitalreset	mgmt_clk				
		tx_ready	Conduit	phy_rst_ctrl_tx_ready	mgmt_clk				
		pll_locked	Conduit	phy_rst_ctrl_pll_locked	mgmt_clk				
		pll_select	Conduit	phy_rst_ctrl_pll_select	mgmt_clk				
		tx_cal_busy	Conduit	phy_rst_ctrl_tx_cal_busy	mgmt_clk				

### Related Information

- [Design Examples for JESD204B IP Core User Guide](#)  
Provides information about design examples for Arria V, Cyclone V, Stratix V, and Intel Arria 10 devices using Intel Quartus Prime Standard Edition software.
- [JESD204B Intel Arria 10 FPGA IP Design Example User Guide](#)
- [JESD204B Intel Stratix 10 FPGA IP Design Example User Guide](#)
- [JESD204B Intel Cyclone 10 GX FPGA IP Design Example User Guide](#)
- [JESD204B Intel Agilex FPGA IP Design Example User Guide](#)

(15) You can also connect conduit interfaces within Platform Designer but you must create adapter components to handle all the incompatibility issues like incompatible signal type and width.





### 3.8.2. Pin Assignments

Set the pin assignments before you compile to provide direction to the Intel Quartus Prime software Fitter tool. You must also specify the signals that should be assigned to device I/O pins.

You can create virtual pins to avoid making specific pin assignments for top-level signals. This is useful when you want to perform compilation, but are not ready to map the design to hardware. Intel recommends that you create virtual pins for all unused top-level signals to improve timing closure.

*Note:* Do not create virtual pins for the clock or reset signals.

For Intel Agilex and Intel Stratix 10 E-tile devices, use the *E-Tile Channel Placement Tool* to get a valid pinout. Specify the transceiver mode as PMA direct - NRZ.

#### Related Information

##### [E-Tile Channel Placement Tool](#)

For E-tile devices, use the channel placement tool to assist you in making pin assignments.

### 3.8.3. Adding External Transceiver PLLs

The JESD204B IP core variations that target an Intel Stratix 10 L-tile, Intel Stratix 10 H-tile, Intel Arria 10, or Intel Cyclone 10 GX FPGA device, require external transceiver PLLs for compilation. Select medium bandwidth for the PLL settings.

*Note:* For Intel Agilex and Intel Stratix 10 E-tile devices, the transceiver PLL is within the transceiver itself; so the design does not require external PLLs.

JESD204B IP variations that target an Arria V, Cyclone V, or Stratix V FPGA device contain transceiver PLLs. Therefore, no external PLLs are required for compilation.

Intel recommends that you follow the PLL recommendations in the respective Transceiver PHY user guides based on the data rates.

*Note:* The PMA width is 20 bits for Hard PCS and 40 bits for Soft PCS.

#### Related Information

- [V-Series Transceiver PHY User Guide](#)
- [Intel Arria 10 Transceiver PHY User Guide](#)
- [Intel Cyclone 10 GX Transceiver PHY User Guide](#)
- [Intel Stratix 10 L- and H-tile Transceiver PHY User Guide](#)
- [E-tile Transceiver PHY User Guide](#)

### 3.8.4. Timing Constraints For Input Clocks

When you generate the JESD204B IP variation, the Intel Quartus Prime software generates a Synopsys Design Constraints File (.sdc) that specifies the timing constraints for the input clocks to your IP.

When you generate the JESD204B IP, your design is not yet complete and the JESD204B IP is not yet connected in the design. The final clock names and paths are not yet known. Therefore, the Intel Quartus Prime software cannot incorporate the final signal names in the `.sdc` file that it automatically generates. Instead, you must manually modify the clock signal names in this file to integrate these constraints with the timing constraints for your full design.

This section describes how to integrate the timing constraints that the Intel Quartus Prime software generates with your IP into the timing constraints for your design.

The Intel Quartus Prime software automatically generates the `altera_jesd204.sdc` file that contains the JESD204B IP's timing constraints.

Three clocks are created at the input clock port:

- JESD204B TX IP:
  - `txlink_clk`
  - `reconfig_to_xcvr[0]` (for Arria V, Cyclone V, and Stratix V devices only)
  - `reconfig_clk` (for Intel Arria 10, Intel Cyclone 10 GX, and Intel Stratix 10 devices only)
  - `tx_avs_clk`
- JESD204B RX IP:
  - `rxlink_clk`
  - `reconfig_to_xcvr[0]` (for Arria V, Cyclone V, and Stratix V devices only)
  - `reconfig_clk` (for Intel Arria 10, Intel Cyclone 10 GX, and Intel Stratix 10 devices only)
  - `rx_avs_clk`

In a functional system design, these clocks (except for `reconfig_to_xcvr[0]` clock) are typically provided by the core PLL.

In the `.sdc` file for your project, make the following command changes:

- Specify the PLL clock reference pin frequency using the `create_clock` command.
- Derive the PLL generated output clocks from the PLL Intel FPGA IP (for Arria V, Cyclone V and Stratix V) or IOPLL Intel FPGA IP (for Intel Arria 10 and Intel Cyclone 10 GX) using the `derive_pll_clocks` command.
- For Intel Stratix 10 devices, Intel FPGA IOPLL IP core has SDC file which derives the PLL clocks based on your PLL configurations. You need not add the `derive_pll_clocks` command into your top level SDC file."
- Comment out the `create_clock` commands for the `txlink_clk`, `reconfig_to_xcvr[0]` or `reconfig_clk`, and `tx_avs_clk`, `rxlink_clk`, and `rx_avs_clk` clocks in the `altera_jesd204.sdc` file.
- Identify the base and generated clock name that correlates to the `txlink_clk`, `reconfig_clk`, and `tx_avs_clk`, `rxlink_clk`, and `rx_avs_clk` clocks using the `report_clock` command.
- Describe the relationship between base and generated clocks in the design using the `set_clock_groups` command.



After you complete your design, you must modify the clock names in your `.sdc` file to the full-design clock names, taking into account both the IP instance name in the full design, and the design hierarchy. Be careful when adding the timing exceptions based on your design, for example, when the JESD204B IP handles asynchronous timing between the `txlink_clk`, `rxlink_clk`, `pll_ref_clk`, `tx_avs_clk`, `rx_avs_clk`, and `reconfig_clk` (for Intel Arria 10, Intel Cyclone 10 GX, and Intel Stratix 10 only) clocks.

The table below shows an example of clock names in the `altera_jesd204.sdc` and input clock names in the user design. In this example, there is a dedicated input clock for the transceiver TX PLL and CDR at the `refclk` pin. The `device_clk` is the input to the core PLL `clk` pin. The IP and transceiver Avalon-MM interfaces have separate external clock sources with different frequencies.

**Table 13. Example A**

Original clock names in <code>altera_jesd204.sdc</code>	User design input clock names	Frequency (MHz)	Recommended SDC timing constraint
<code>tx_pll_ref_clk</code>	<code>xcvr_tx_rx_refclk</code>	250	<pre>create_clock -name xcvr_tx_rx_refclk -period 4.0 [get_ports xcvr_tx_rx_refclk ] create_clock -name device_clk -period 8.0 [get_ports device_clk]</pre>
<code>rx_pll_ref_clk</code>			
<code>txlink_clk</code>	<code>device_clk</code>	125	<pre>create_clock -name jesd204_avs_clk -period 10.0 [get_ports jesd204_avs_clk]</pre>
<code>rxlink_clk</code>			
<code>tx_avs_clk</code>	<code>jesd204_avs_clk</code>	100	<pre>create_clock -name phy_mgmt_clk -period 13.3 [get_ports phy_mgmt_clk] derive_pll_clocks set_clock_groups -asynchronous \ -group {xcvr_tx_rx_refclk \ &lt;base and generated clock names as reported by report_clock commands&gt; \ } \ -group {device_clk \ &lt;base and generated clock names as reported by report_clock commands&gt; \ } \ -group {jesd204_avs_clk} \ -group {phy_mgmt_clk \ &lt;base and generated clock names as reported by report_clock commands&gt; \ }</pre>
<code>rx_avs_clk</code>			
<code>reconfig_clk</code> <sup>(16)</sup>	<code>phy_mgmt_clk</code>	75	

However, if your design requires you to connect the `rx_avs_clk` and `reconfig_clk` to the same clock, you need to put them in the same clock group.

The table below shows an example where the `device_clk` in this design is an input into the transceiver `refclk` pin. The IP's Avalon-MM interface shares the same clock source as the transceiver management clock.

(16) For Intel Arria 10, Intel Cyclone 10 GX, and Intel Stratix 10 only.



Table 14. Example B

Original clock names in altera_jesd204.sdc	User design input clock names	Frequency (MHz)	Recommended SDC timing constraint
tx_pll_ref_clk	device_clk	125	<pre>create_clock -name device_clk -period 8.0 [get_ports device_clk] create_clock -name mgmt_clk -period 10.0 [get_ports mgmt_clk] derive_pll_clocks set_clock_groups -asynchronous \ -group {device_clk \ &lt;base and generated clock names as reported by report_clock commands&gt; \ } \ -group {mgmt_clk \ &lt;base and generated clock names as reported by report_clock commands&gt; \ }</pre>
rx_pll_ref_clk			
txlink_clk			
rxlink_clk			
tx_avs_clk	mgmt_clk	100	<pre>set_clock_groups -asynchronous \ -group {device_clk \ &lt;base and generated clock names as reported by report_clock commands&gt; \ } \ -group {mgmt_clk \ &lt;base and generated clock names as reported by report_clock commands&gt; \ }</pre>
rx_avs_clk			
reconfig_clk <sup>(17)</sup>			

### 3.9. JESD204B Intel FPGA IP Parameters

Table 15. JESD204B Intel FPGA IP Parameters

Parameter	Value	Description
<b>Main Tab</b>		
Device Family	<ul style="list-style-type: none"> <li>Intel Agilex</li> <li>Intel Stratix 10</li> <li>Intel Arria 10</li> <li>Intel Cyclone 10 GX</li> <li>Stratix V</li> <li>Cyclone V</li> <li>Arria V</li> <li>Arria V GZ</li> </ul>	The targeted device family.
JESD204B Wrapper	<ul style="list-style-type: none"> <li>Base Only</li> <li>PHY Only</li> <li>Both Base and PHY</li> </ul>	Select the JESD204B wrapper. <ul style="list-style-type: none"> <li>Base Only—generates the DLL only.</li> <li>PHY Only—generates the transceiver PHY layer only (soft and hard PCS).</li> <li>Both Base and PHY—generates both DLL and transceiver PHY layers.</li> </ul>
Data Path	<ul style="list-style-type: none"> <li>Receiver</li> <li>Transmitter</li> <li>Duplex</li> </ul>	Select the operation modes. This selection enables or disables the receiver and transmitter supporting logic. <ul style="list-style-type: none"> <li>RX—instantiates the receiver to interface to the ADC.</li> <li>TX—instantiates the transmitter to interface to the DAC.</li> <li>Duplex—instantiates the receiver and transmitter to interface to both the ADC and DAC.</li> </ul>
JESD204B Subclass	<ul style="list-style-type: none"> <li>0</li> <li>1</li> <li>2</li> </ul>	Select the JESD204B subclass modes. <ul style="list-style-type: none"> <li>0—Set subclass 0</li> <li>1—Set subclass 1</li> <li>2—Set subclass 2</li> </ul>
<i>continued...</i>		

(17) For Intel Agilex, Intel Stratix 10, Intel Cyclone 10 GX, and Intel Arria 10 only.



Parameter	Value	Description
Data Rate	1.0–19.2	<p>Set the data rate for each lane.</p> <ul style="list-style-type: none"> <li>Intel Agilex (E-tile)—2.0 Gbps to 19.2 Gbps</li> <li>Intel Stratix 10 (L-tile, H-tile, and E-tile)—2.0 Gbps to 16.0 Gbps</li> <li>Intel Cyclone 10 GX—2.0 Gbps to 6.25 Gbps</li> <li>Intel Arria 10—2.0 Gbps to 15.0 Gbps</li> <li>Stratix V—2.0 Gbps to 12.5 Gbps</li> <li>Cyclone V—1.0 Gbps to 5.0 Gbps</li> <li>Arria V—1.0 Gbps to 7.5 Gbps</li> <li>Arria V GZ—2.0 Gbps to 9.9 Gbps</li> </ul> <p><i>Note:</i> The maximum data rate is limited due to different device speed grades, transceiver PMA speed grades, and PCS options. Refer to <a href="#">Performance and Resource Utilization</a> on page 14 for the maximum data rate support.</p>
Transceiver Tile	<ul style="list-style-type: none"> <li>E-tile</li> <li>H-tile</li> </ul>	<p>This option is available only when you target an Intel Stratix 10 device that supports both H-tile and E-tile. Select the transceiver tile you want for your design.</p> <p>When you select <b>E-tile</b>, you can only use soft PCS.</p> <p><i>Note:</i> For simplex variants with E-tile transceiver, the underneath transceiver is in duplex mode. The merging of independent TX and RX within a transceiver channel is not supported in this version.</p>
PCS Option	<ul style="list-style-type: none"> <li>Enabled Hard PCS</li> <li>Enabled Soft PCS</li> <li>Enabled PMA Direct</li> </ul>	<p>Select the PCS modes.</p> <ul style="list-style-type: none"> <li>Enabled Hard PCS—use Hard PCS components. Select this option to minimize resource utilization with data rate that supports up to the limitation of the Hard PCS.</li> </ul> <p><i>Note:</i> For this setting, use 8G PCS mode with 20 bits PMA width and 32-bit PCS width.</p> <ul style="list-style-type: none"> <li>Enabled Soft PCS—use Soft PCS components. Select this option to allow higher supported data rate but increases the resource utilization. This option is applicable for all devices except Cyclone V and Arria V GT/ST.</li> </ul> <p><i>Note:</i> For this setting, use 10G PCS mode with 40 bits PMA width and 40 bits PCS width.</p> <ul style="list-style-type: none"> <li>Enabled PMA Direct—Native PHY is set to PMA Direct mode. Select this option to allow the highest supported data rate and to maximize the resource utilization. This option is applicable only for Arria V GT/ST devices.</li> </ul> <p><i>Note:</i> For this setting, use PMA Direct mode with 80-bit PMA width.</p>
PLL Type	<ul style="list-style-type: none"> <li>CMU</li> <li>ATX</li> </ul>	<p>Select the phase-locked loop (PLL) types, depending on the FPGA device family. This parameter is not applicable to Intel Arria 10, Intel Cyclone 10 GX, and Intel Stratix 10 devices.</p> <ul style="list-style-type: none"> <li>Cyclone V—CMU</li> <li>Arria V—CMU</li> <li>Stratix V—CMU, ATX</li> </ul>
Bonding Mode	<ul style="list-style-type: none"> <li>Bonded</li> <li>Non-bonded</li> </ul>	<p>Select the bonding modes.</p> <ul style="list-style-type: none"> <li>Bonded—select this option to minimize inter-lanes skew for the transmitter datapath.</li> <li>Non-bonded—select this option to disable inter-lanes skew control for the transmitter datapath.</li> </ul> <p><i>Note:</i> For Stratix V, Arria V, and Cyclone V devices, the bonding type is automatically selected based on the device family and number of lanes that you set.</p>

**continued...**



Parameter	Value	Description
PLL/CDR Reference Clock Frequency	Variable	Set the transceiver reference clock frequency for PLL or CDR. <ul style="list-style-type: none"> <li>For Stratix V, Arria V, and Cyclone V devices, the frequency range available for you to choose depends on the PLL type and data rate that you select.</li> <li>For Intel Agilex, Intel Stratix 10, Intel Cyclone 10 GX, and Intel Arria 10 devices, the frequency range available for you to choose depends on the data rate.</li> </ul>
VCCR_GXB and VCCT_GXB Supply Voltage for the Transceiver	<ul style="list-style-type: none"> <li>1.1V</li> <li>1.0V</li> </ul>	Select the supply voltage for the transceiver. For details about the minimum, typical, and maximum supply voltage specifications, refer to the <i>Intel Stratix 10 Device Datasheet</i> . <i>Note:</i> Available only for Intel Stratix 10 L-tile and H-tile devices.
Enable Bit reversal and Byte reversal	On, Off	The JESD204B IP uses four 10-bit symbols (denoted as symbol3, symbol2, symbol1, and symbol0) for the 8B/10B encoding scheme. Symbol0 is the first symbol to be shifted out through the serial link while symbol3 is the last symbol to be shifted out. <ul style="list-style-type: none"> <li>Turn off this option to set the data transmission order to start from the least significant bit (lsb) of each symbol. For example, symbol0[0] is shifted out first, followed by symbol0[1], and so on until the entire symbol0 is shifted out. The transmission continues with symbol1[0] through symbol3[9].</li> <li>Turn on this option to set the data transmission order to start from the most significant bit (msb) of each symbol. For example, symbol0[9] is shifted out first, followed by symbol0[8], and so on until the entire symbol0 is shifted out. The transmission continues with symbol1[9] through symbol3[0].</li> </ul>
Enable Transceiver Dynamic Reconfiguration	On, Off	Turn on this option to enable dynamic data rate change. For V series devices, when you enable this option, you need to connect the reconfiguration interface to the transceiver reconfiguration controller. <sup>(18)</sup> For Intel Arria 10, Intel Cyclone 10 GX, and Intel Stratix 10 devices, turn on this option to enable the Transceiver Native PHY reconfiguration interface.
Enable Native PHY Debug Master Endpoint <sup>(19)</sup>	On, Off	Turn on this option for the Transceiver Native PHY IP core to include an embedded Native PHY Debug Master Endpoint. This block connects internally to the Avalon-MM slave interface of the Transceiver Native PHY and can access the reconfiguration space of the transceiver. It can perform certain test and debug functions via JTAG using System Console. This parameter is valid only when you turn on the <b>Enable Transceiver Dynamic Reconfiguration</b> parameter. <i>Note:</i> Available only for Intel Agilex, Intel Stratix 10, Intel Cyclone 10 GX, and Intel Arria 10 devices.
Share Reconfiguration Interface <sup>(19)</sup>	On, Off	When enabled, Transceiver Native PHY presents a single Avalon-MM slave interface for dynamic reconfiguration of all channels. In this configuration the upper address bits (Intel Stratix 10: [log <sub>2</sub> <L>+10:11]; Intel Arria 10/Intel Cyclone 10 GX: [log <sub>2</sub> <L>+9:10]) of the reconfiguration address bus specify the selected channel. The upper address bits only exist when L>1. Address bits (Intel Stratix 10: [10:0]; Intel Arria 10/Intel Cyclone 10 GX: [9:0]) provide the register offset address within the reconfiguration space of the selected channel. L is the number of channel.

*continued...*

<sup>(18)</sup> To perform dynamic reconfiguration, you have to instantiate the Transceiver Reconfiguration Controller from the IP Catalog and connect it to the JESD204B IP core through the `reconfig_to_xcvr` and `reconfig_from_xcvr` interface.

<sup>(19)</sup> To support the Transceiver Toolkit in your design, you must turn on this option.



Parameter	Value	Description
		<p>When disabled, the Native PHY IP core provides an independent reconfiguration interface for each channel. For example, when a reconfiguration interface is not shared for a four-channel Native PHY IP instance, <code>reconfig_address[9:0]</code> corresponds to the reconfiguration address bus of logical channel 0, <code>reconfig_address[19:10]</code> correspond to the reconfiguration address bus of logical channel 1, <code>reconfig_address[29:20]</code> corresponds to the reconfiguration address bus of logical channel 2, and <code>reconfig_address[39:30]</code> correspond to the reconfiguration address bus of logical channel 3.</p> <p>For configurations using more than one channel, this option must be enabled when you turn on <b>Enable Native PHY Debug Master Endpoint</b>.</p> <p><i>Note:</i> Available only for Intel Agilex, Intel Stratix 10, Intel Cyclone 10 GX, and Intel Arria 10 devices.</p>
Provide Separate Reconfiguration Interface for Each Channel	On, Off	<p>When enabled, transceiver dynamic reconfiguration interface presents separate clock, reset, and Avalon-MM slave interface for each channel instead of a single wide bus. This option is only available when <b>Share Reconfiguration Interface</b> is turned off.</p> <p><i>Note:</i> Available in Intel Quartus Prime Pro Edition only.</p>
Enable Capability Registers <sup>(19)</sup>	On, Off	<p>Turn on this option to enable capability registers, which provides high level information about the transceiver channel's configuration.</p> <p><i>Note:</i> Available only for Intel Agilex, Intel Stratix 10, Intel Cyclone 10 GX, and Intel Arria 10 devices.</p>
Set user-defined IP identifier	0–255	<p>Set a user-defined numeric identifier that can be read from the user identifier offset when you turn on the <code>Enable Capability Registers</code> parameter.</p> <p><i>Note:</i> Available only for Intel Agilex, Intel Stratix 10, Intel Cyclone 10 GX, and Intel Arria 10 devices.</p>
Enable Control and Status Registers <sup>(19)</sup>	On, Off	<p>Turn on this option to enable soft registers for reading status signals and writing control signals on the PHY interface through the embedded debug. For more information, refer to the respective <i>Transceiver User Guides</i>.</p> <p><i>Note:</i> Available only for Intel Agilex, Intel Stratix 10, Intel Cyclone 10 GX, and Intel Arria 10 devices.</p>
Enable PRBS Soft Accumulators <sup>(19)</sup>	On, Off	<p>Turn on this option to set the soft logic to perform pseudorandom binary sequence (PRBS) bit and error accumulation when using the hard PRBS generator and checker.</p> <p><i>Note:</i> Available only for Intel Agilex, Intel Stratix 10, Intel Cyclone 10 GX, and Intel Arria 10 devices.</p>

JESD204B Configurations Tab		
Lanes per converter device (L)	1–8	<p>Set the number of lanes per converter device.</p> <p><i>Note:</i> Refer to <a href="#">Performance and Resource Utilization</a> on page 14 for the common supported range for L and the resource utilization.</p>
Converters per device (M)	1–256	<p>Set the number of converters per converter device.</p>
Enable manual F configuration	On, Off	<p>Turn on this option to set parameter F in manual mode and enable this parameter to be configurable. Otherwise, the parameter F is in derived mode.</p> <p>You have to enable this parameter and configure the appropriate F value if the transport layer in your design is supporting Control Word (CF) or High Density format(HD), or both.</p>
<i>continued...</i>		



		<i>Note:</i> The auto derived F value using formula $F=M*S*N\sqrt{(8*L)}$ may not apply if parameter CF or parameter HD, or both are enabled.
Octets per frame (F)	<ul style="list-style-type: none"> <li>1–256 (for Intel Stratix 10 devices only)</li> <li>1, 2, 4–256 (for non Intel Stratix 10 devices)</li> </ul>	The number of octets per frame is derived from $F= M*N*S/(8*L)$ .
Converter resolution (N)	1–32	Set the number of conversion bits per converter.
Transmitted bits per sample (N')	1–32	Set the number of transmitted bits per sample (JESD204 word size, which is in nibble group). <i>Note:</i> If parameter CF equals to 0 (no control word), parameter N' must be larger than or equal to sum of parameter N and parameter CS ( $N' \geq N + CS$ ). Otherwise, parameter N' must be larger than or equal to parameter N ( $N' \geq N$ ).
Samples per converter per frame (S)	1–32	Set the number of transmitted samples per converter per frame.
Frames per multiframe (K)	1–32	Set the number of frames per multiframe. This value is dependent on the value of F and is derived using the following constraints: <ul style="list-style-type: none"> <li>The value of K must fall within the range of <math>17/F \leq K \leq \min(32, \text{floor}(1024/F))</math></li> <li>The value of <math>F*K</math> must be divisible by 4</li> </ul>
Enable scramble (SCR)	On, Off	Turn on this option to scramble the transmitted data or descramble the receiving data.
Control Bits (CS)	0–3	Set the number of control bits per conversion sample.
Control Words (CF)	0–32	Set the number of control words per frame clock period per link.
High density user data format (HD)	On, Off	Turn on this option to set the data format. This parameter controls whether a sample may be divided over more lanes. <ul style="list-style-type: none"> <li>On: High Density format</li> <li>Off: Data should not cross the lane boundary</li> </ul>
Enable Error Code Correction (ECC_EN)	On, Off	Turn on this option to enable error code correction (ECC) for memory blocks.
Phase adjustment request (PHADJ)	On, Off	Turn on this option to specify the phase adjustment request to the DAC. <ul style="list-style-type: none"> <li>On: Request for phase adjustment</li> <li>Off: No phase adjustment</li> </ul> This parameter is valid for Subclass 2 mode only.
Adjustment resolution step count (ADJCNT)	0–15	Set the adjustment resolution for the DAC LMFC. This parameter is valid for Subclass 2 mode only.
Direction of adjustment (ADJDIR)	<ul style="list-style-type: none"> <li>Advance</li> <li>Delay</li> </ul>	Select to adjust the DAC LMFC direction. This parameter is valid for Subclass 2 mode only.

Configurations and Status Registers Tab		
Device ID	0–255	Set the device ID number.
Bank ID	0–15	Set the device bank ID number.
Lane# ID	0–31	Set the lane ID number.
Lane# checksum	0–255	Set the checksum for each lane ID.





**Note:** The **PMA Adaptation** parameters are available only for Intel Agilex and Intel Stratix 10 E-tile devices. For more information about the **PMA Adaptation** parameters, refer to the *PMA Adaptation* section in the *E-tile Transceiver PHY User Guide*.

**Related Information**

- [E-tile Transceiver PHY User Guide](#)
- [Performance and Resource Utilization](#) on page 14

### 3.10. JESD204B IP Component Files

The following table describes the generated files and other files that may be in your project directory. The names and types of generated files specified may vary depending on whether you create your design with VHDL or Verilog HDL.

**Table 16. Generated Files**

Extension	Description
<variation name>.v or .vhd	IP variation file, which defines a VHDL or Verilog HDL description of the custom IP. Instantiate the entity defined by this file inside of your design. Include this file when compiling your design in the Intel Quartus Prime software.
<variation name>.cmp	A VHDL component declaration file for the IP variation. Add the contents of this file to any VHDL architecture that instantiates the IP.
<variation name>.sdc	Contains timing constraints for your IP variation.
<variation name>.qip or .ip	Contains Intel Quartus Prime project information for your IP variation.
<variation name>.tcl	Tcl script file to run in Intel Quartus Prime software.
<variation name>.sip	Contains IP library mapping information required by the Intel Quartus Prime software. The Intel Quartus Prime software generates a .sip file during generation of some Intel FPGA IPs. You must add any generated .sip file to your project for use by NativeLink simulation and the Intel Quartus Prime Archiver.
<variation name>.spd	Contains a list of required simulation files for your IP.

### 3.11. JESD204B IP Testbench

The JESD204B IP includes a testbench to demonstrate a normal link-up sequence for the JESD204B IP with a supported configuration. The testbench also provides an example of how to control the JESD204B IP interfaces.

The testbench instantiates the JESD204B IP in duplex mode and connects with the Intel FPGA Transceiver PHY Reset Controller IP. Some configurations are preset and are not programmable in the JESD204B IP testbench. For example, the JESD204B IP always instantiates in duplex mode even if RX or TX mode is selected in the JESD204B parameter editor.

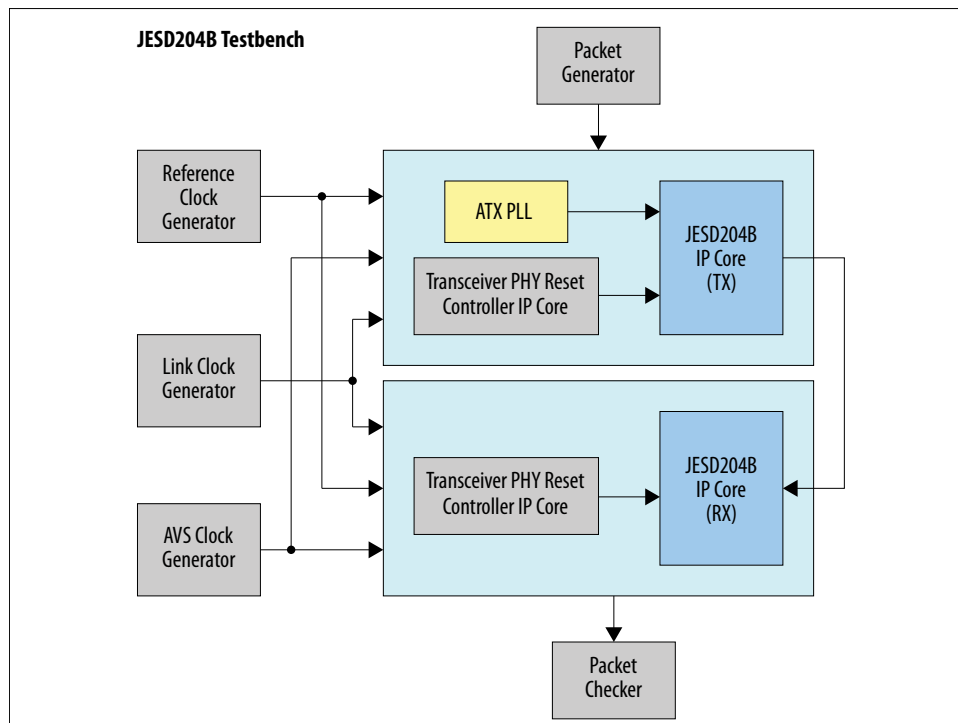
**Table 17. Preset Configurations for JESD204B IP Testbench**

Configuration	Preset Value
JESD204B Wrapper	Base and PHY (MAC and PHY)
Data Path	Simplex TX and simplex RX
PLL/CDR Reference Clock Frequency <sup>(20)</sup>	For Base only, or Simplex TX variants:
<i>continued...</i>	

Configuration	Preset Value
	<ul style="list-style-type: none"> <li>Data_rate/20 (if you turn on <b>Enabled Hard PCS</b>)</li> <li>Data_rate/40 (if you turn on <b>Enabled Soft PCS</b>)</li> <li>Data_rate/80 (if you turn on <b>Enabled PMA Direct</b>)</li> </ul>
Link Clock	Data_rate/40
AVS Clock	100 MHz

**Figure 8. JESD204B IP Testbench Block Diagram**

The external ATX PLL is present only in the JESD204B IP testbench targeting Intel Arria 10, Intel Cyclone 10 GX, and Intel Stratix 10 L-tile and H-tile devices. For Intel Agilex and Intel Stratix 10 E-tile devices, the Transceiver PHY Reset Controller is within the transceiver block.



### 3.11.1. Generating and Simulating the IP Testbench

You can simulate your JESD204B IP variation by using the provided IP demonstration testbench.

To use the JESD204B IP testbench, follow these steps:

1. Generate the simulation model. Refer to [Generating the Testbench Simulation Model](#) on page 43.
2. Simulate the testbench using the simulator-specific scripts that you have generated. Refer to [Simulating the IP Testbench](#) on page 43.

<sup>(20)</sup> For the ATX PLL supported range of reference clock frequencies, refer to the respective device datasheet.



**Note:** Some configurations are preset and are not programmable in the JESD204B IP testbench. For more details, refer to [JESD204B IP Testbench](#) on page 41 or the README.txt file located in the <example\_design\_directory>/ip\_sim folder.

### 3.11.1.1. Generating the Testbench Simulation Model

To generate the testbench simulation model, execute the generated script (*gen\_sim\_verilog.tcl* or *gen\_sim\_vhdl.tcl*) located in the <example\_design\_directory>/ip\_sim folder.

To run the Tcl script using the Intel Quartus Prime software, follow these steps:

1. Launch the Intel Quartus Prime software.
2. On the View menu, click **Utility Windows > Tcl Console**.
3. In the **Tcl Console**, type `cd <example_design_directory>/ip_sim` to go to the specified directory.
4. Type `source gen_sim_verilog.tcl` (Verilog) or `source gen_sim_vhdl.tcl` (VHDL) to generate the simulation files.

To run the Tcl script using the command line, follow these steps:

1. Obtain the Intel Quartus Prime software resource.
2. Type `cd <example_design_directory>/ip_sim` to go to the specified directory.
3. Type `quartus_sh -t gen_sim_verilog.tcl` (Verilog) or `quartus_sh -t gen_sim_vhdl.tcl` (VHDL) to generate the simulation files.

### 3.11.1.2. Simulating the IP Testbench

**Note:** VHDL is not supported in VCS simulator.

**Table 18. Simulation Setup Scripts**

Simulator	File Directory	Script
ModelSim - Intel FPGA Edition/ModelSim - Intel FPGA Starter Edition	<example_design_directory>/ip_sim/testbench/setup_scripts/mentor	msim_setup.tcl
Synopsys VCS simulator	<example_design_directory>/ip_sim/testbench/setup_scripts/synopsys/vcs	vcs_setup.sh
Synopsys VCS-MX simulator	<example_design_directory>/ip_sim/testbench/setup_scripts/synopsys/vcsmx	vcsmx_setup.sh synopsys_sim.setup
Aldec Riviera-PRO <i>Note:</i> Intel Agilex and Intel Stratix 10 E-tile devices do not support this simulator.	<example_design_directory>/ip_sim/testbench/setup_scripts/aldec	rivierapro_setup.tcl
Cadence NCSim	<example_design_directory>/ip_sim/testbench/setup_scripts/cadence	ncsim_setup.sh
Cadence Xcelium Parallel simulator	<example_design_directory>/ip_sim/testbench/setup_scripts/xcelium	xcelium_setup.sh

**Table 19. Simulation Run Scripts**

Simulator	File Directory	Script
ModelSim - Intel FPGA Edition/ModelSim - Intel FPGA Starter Edition	<example_design_directory>/ip_sim/testbench/mentor	run_altera_jesd204_tb.tcl
Synopsys VCS simulator	<example_design_directory>/ip_sim/testbench/synopsys/vcs	run_altera_jesd204_tb.sh
Synopsys VCS-MX simulator	<example_design_directory>/ip_sim/testbench/synopsys/vcsmx	run_altera_jesd204_tb.sh
Aldec Riviera-PRO <i>Note: Intel Agilex and Intel Stratix 10 E-tile devices do not support this simulator.</i>	<example_design_directory>/ip_sim/testbench/aldec	run_altera_jesd204_tb.tcl
Cadence NCSim	<example_design_directory>/ip_sim/testbench/cadence	run_altera_jesd204_tb.sh
Cadence Xcelium Parallel simulator	<example_design_directory>/ip_sim/testbench/xcelium	run_altera_jesd204_tb.sh

To simulate the testbench design using the ModelSim - Intel FPGA Edition/ModelSim - Intel FPGA Starter Edition, follow these steps:

1. Launch the ModelSim - Intel FPGA Edition/ModelSim - Intel FPGA Starter Edition.
2. On the File menu, click **Change Directory > Select** <example\_design\_directory>/ip\_sim/testbench/<simulator name>.
3. On the File menu, click **Load > Macro file**. Select **run\_altera\_jesd204\_tb.tcl**. This file compiles the design and runs the simulation automatically, providing a pass/fail indication on completion.

To simulate the testbench design using the Aldec Riviera-PRO simulator, follow these steps:

1. Launch the Aldec Riviera-PRO simulator.
2. On the File menu, click **Change Directory > Select** <example\_design\_directory>/ip\_sim/testbench/<simulator name>.
3. On the Tool menu, click **Execute Macro**. Select **run\_altera\_jesd204\_tb.tcl**. This file compiles the design and runs the simulation automatically, providing a pass/fail indication on completion.

To simulate the testbench design using the VCS, VCS MX (in Linux), or Cadence simulators, follow these steps:

1. Launch the Synopsys VCS or VCS-MX, or Cadence NCSim or Xcelium Parallel simulator.
2. On the File menu, click **Change Directory > Select** <example\_design\_directory>/ip\_sim/testbench/<simulator name>.
3. Run the **run\_altera\_jesd204\_tb.sh** file. This file compiles the design and runs the simulation automatically, providing a pass/fail indication on completion.



## Related Information

### *Simulating Intel FPGA Designs*

More information about Intel FPGA simulation models.

## 3.11.2. Testbench Simulation Flow

The JESD204B testbench simulation flow:

1. At the start, the system is under reset (all the components are in reset).
2. After 100 ns, the Transceiver Reset Controller IP core power up and wait for the `tx_ready` and `rx_ready` signal from the Transceiver Reset Controller IP to assert.
3. After 500 ns (all devices except Intel Agilex and Intel Stratix 10 E-tile) or 1500 ns (Intel Agilex and Intel Stratix 10 E-tile devices), the reset signal of the JESD204B TX Avalon-MM interface is released (go HIGH). At the next positive edge of the `link_clk` signal, the JESD204B TX link powers up by releasing its reset signal.
4. The JESD204B TX link starts transmitting K28.5 characters.
5. The reset signal of the JESD204B RX Avalon-MM interface is released (go HIGH). At the next positive edge of the `link_clk` signal, the JESD204B RX link powers up by releasing its reset signal.
6. Once the link is out of reset, a *SYSREF* pulse is generated to reset the LMFC counter inside both the JESD204B TX and RX IP core.
7. When the `txlink_ready` signal is asserted, the packet generator starts sending packets to the TX datapath.
8. The packet checker starts comparing the packet sent from the TX datapath and received at the RX datapath after the `rxlink_valid` signal is asserted.
9. The testbench reports a pass or fail when all the packets are received and compared.

The testbench concludes by checking that all the packets have been received.

If no error is detected, the testbench issues a `TESTBENCH PASSED` message stating that the simulation was successful. If an error is detected, the testbench issues a `TESTBENCH FAILED` message to indicate that the testbench has failed.

**Note:** For Intel Stratix 10 L-tile and H-tile devices, reset deassertion staggering of TX/RX analog and digital reset happens before the assertion of TX/RX ready. The reset staggering may incur long simulation time. You may observe the staggering of TX and RX reset through `tx_analogreset_stat`, `tx_digitalreset_stat`, `rx_analogreset_stat`, and `rx_digitalreset_stat` respectively.

## 4. JESD204B IP Functional Description

The JESD204B IP implements a transmitter (TX) and receiver (RX) block. Each block has two layers and consists of the following components:

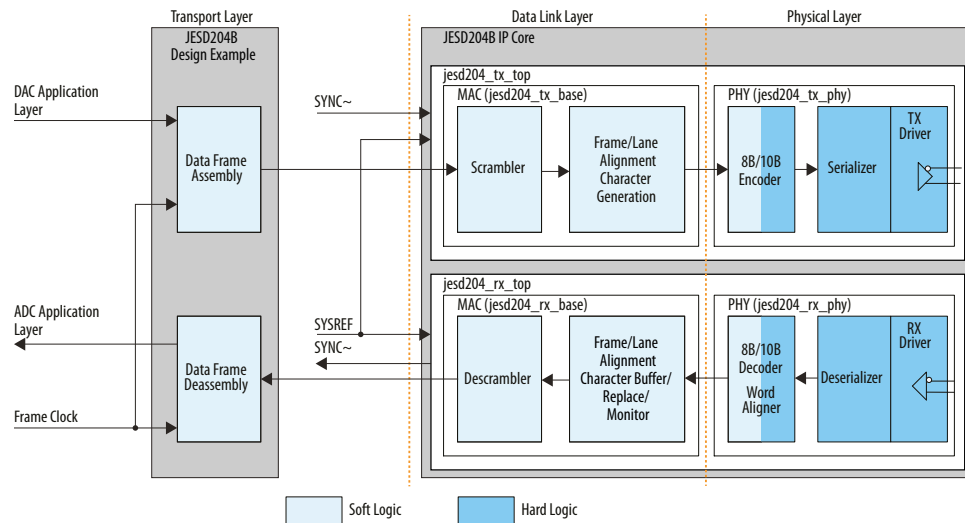
- Media access control (MAC)—DLL block that consists of the link layer (link state machine and character replacement), CSR, Subclass 1 and 2 deterministic latency, scrambler or descrambler, and multiframe counter.
- Physical layer (PHY)—PCS and PMA block that consists of the 8B/10B encoder, word aligner, serializer, and deserializer.

You can specify the datapath and wrapper for your design and generate them separately.

The TX and RX blocks in the DLL utilizes the Avalon-ST interface to transmit or receive data and the Avalon-MM interface to access the CSRs. The TX and RX blocks operate on 32-bit data width per channel, where the frame assembly packs the data into four octets per channel. Multiple TX and RX blocks can share the clock and reset if the link rates are the same.

**Figure 9. Overview of the JESD204B IP Block Diagram**

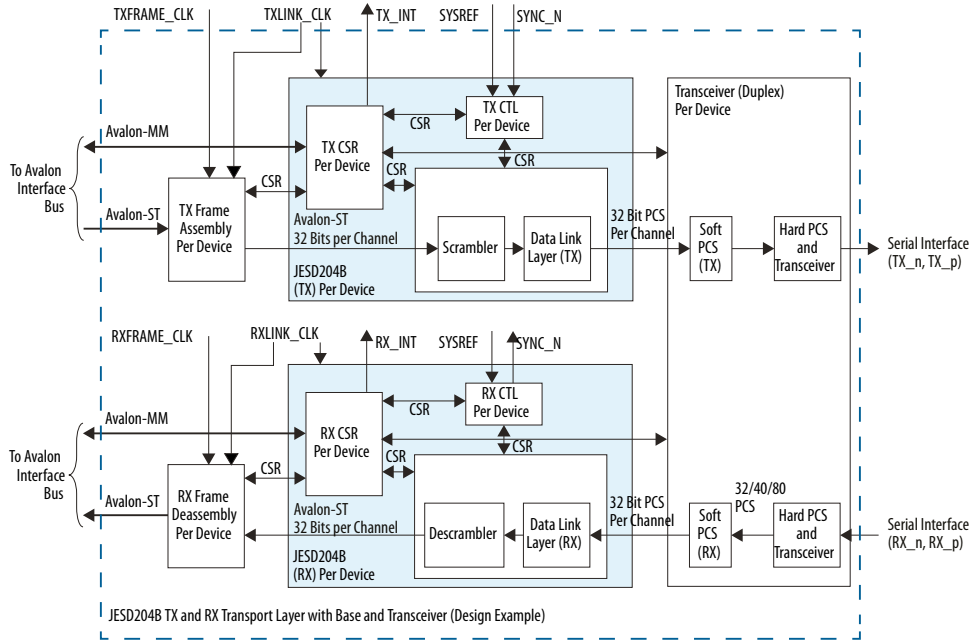
If your design uses hard PCS, the 8B/10B and word aligner blocks should be hard logic, but if your design uses soft PCS, the 8B/10B and word aligner blocks are soft logic.





**Figure 10. JESD204B IP TX and RX Datapath Block Diagram**

The JESD204B IP uses the Avalon-ST source and sink interfaces, with unidirectional flow of data, to transmit and receive data on the FPGA fabric interface.



### 32-Bit Architecture

The JESD204B IP consists of 32-bit internal datapath per lane. This means that JESD204B IP expects the data samples to be assembled into 32-bit data (4 octets) per lane in the transport layer before sending the data to the Avalon-ST data bus. The JESD204B IP operates in the link clock domain. The link clock runs at (data rate/40) because it is operating in 32-bit data bus after 8B/10B encoding.

As the internal datapath of the core is 32 bits, the (F × K) value must be in the order of 4 to align the multiframe length on a 32-bit boundary. Apart from this, the deterministic latency counter values such as LMFC counter, RX Buffer Delay (RBD) counter, and Subclass 2 adjustment counter is the link clock count instead of frame clock count.

### Avalon-ST Interface

The JESD204B IP and transport layer in the design example use the Avalon-ST source and sink interfaces. There is no backpressure mechanism implemented in this core. The JESD204B IP expects continuous stream of data samples from the upstream device.

### Avalon-MM Interface

The Avalon-MM slave interface provides access to internal CSRs. The read and write data width is 32 bits (DWORD access). The Avalon-MM slave is asynchronous to the txlink\_clk, txframe\_clk, rxlink\_clk, and rxframe\_clk clock domains. You

are recommended to release the reset for the CSR configuration space first. All run-time JESD204B configurations like L, F, M, N, N', CS, CF, and HD should be set before releasing the reset for link and frame clock domain.

Each write transfer has a *writeWaitTime* of 0 cycle while a read transfer has a *readWaitTime* of 1 cycle and *readLatency* of 1 cycle.

**Related Information**

*Avalon Interface Specification*

More information about the Avalon-ST and Avalon-MM interfaces, including timing diagrams.

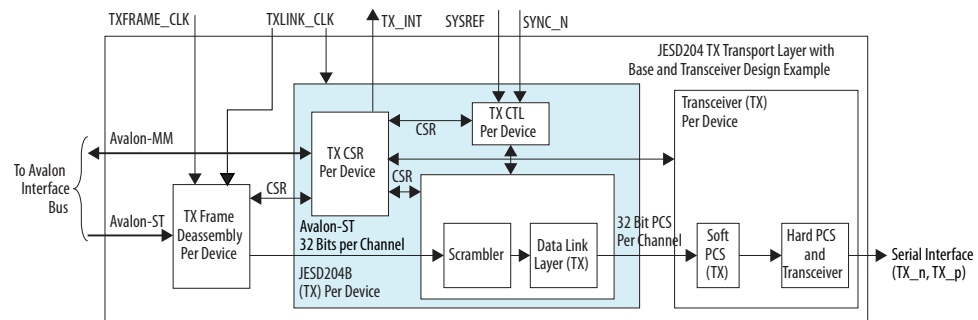
**4.1. Transmitter**

The transmitter block, which interfaces to DAC devices, takes one or more digital sample streams and converts them into one or more serial streams.

The transmitter performs the following functions:

- Data scrambling
- Frame or lane alignment
- Character generation
- Serial lane monitoring
- 8B/10B encoding
- Data serializer

**Figure 11. Transmitter Data Path Block Diagram**



The transmitter block consists of the following modules:

- TX CSR—manages the configuration and status registers.
- TX\_CTL—manages the SYNC\_N signal, state machine that controls the data link layer states, LMFC, and also the deterministic latency throughout the link.
- TX Scrambler and Data Link Layer—takes in 32 bits of data that implements the Initial Lane Alignment Sequence (ILAS), performs scrambling, lane insertion and frame alignment of characters.





### 4.1.1. TX Data Link Layer

The JESD204B IP core TX data link layer includes three phases to establish a synchronized link—Code Group Synchronization (CGS), Initial Lane Synchronization (ILAS), and User Data phase.

#### 4.1.1.1. TX CGS

The CGS phase is achieved through the following process:

- Upon reset, the converter device (RX) issues a synchronization request by driving `SYNC_N` low. The JESD204B TX IP core transmits a stream of `/K/ = /K28.5/` symbols. The receiver synchronizes when it receives four consecutive `/K/` symbols.
- For Subclass 0, the RX converter devices deassert `SYNC_N` signal at the frame boundary. After all receivers have deactivated their synchronization requests, the JESD204B TX IP core continues to emit `/K/` symbols until the start of the next frame. The core proceeds to transmit ILAS data sequence or encoded user data if `csr_lane_sync_en` signal is disabled.
- For Subclass 1 and 2, the RX converter devices deassert `SYNC_N` signal at the LMFC boundary. After all receivers deactivate the `SYNC_N` signal, the JESD204B TX IP core continues to transmit `/K/` symbols until the next LMFC boundary. At the next LMFC boundary, the JESD204B IP core transmits ILAS data sequence. (There is no programmability to use a later LMFC boundary.)

#### 4.1.1.2. TX ILAS

When lane alignment sequence is enabled through the `csr_lane_sync_en` register, the ILAS sequence is transmitted after the CGS phase. The ILAS phase takes up four multiframes. For Subclass 0 mode, you can program the CSR (`csr_ilas_multiframe`) to extend the ILAS phase to a maximum of 256 multiframes before transitioning to the encoded user data phase. The ILAS data is not scrambled regardless of whether scrambling is enabled or disabled.

The multiframe has the following structure:

- Each multiframe starts with a `/R/` character (K28.0) and ends with a `/A/` character (K28.3)
- The second multiframe transmits the ILAS configuration data. The multiframe starts with `/R/` character (K28.0), followed by `/Q/` character (K28.4), and then followed by the link configuration data, which consists of 14 octets as illustrated in the table below. It is then padded with dummy data and ends with `/A/` character (K28.3), marking the end of multiframe.
- Dummy octets are an 8-bit counter and is always reset when it is not in ILAS phase.
- For a configuration of more than four multiframes, the multiframe follows the same rule above and is padded with dummy data in between `/R/` character and `/A/` character.



**Table 20. Link Configuration Data Transmitted in ILAS Phase**

Configu- ration Octet	Bits								Description
	MSB	6	5	4	3	2	1	LSB	
0	DID[7:0]								DID = Device ID
1	ADJCNT[3:0]				BID[3:0]				ADJCNT = Number of adjustment resolution steps <sup>(21)</sup> BID = Bank ID
2	0	ADJDIR	PHADJ	LID[4:0]					ADJDIR = Direction to adjust DAC LMFC <sup>(21)</sup> PHADJ = Phase adjustment request <sup>(21)</sup> LID = Lane ID
3	SCR	0	0	L[4:0]					SCR = Scrambling enabled/disabled L = Number of lanes per device (link)
4	F[7:0]								F = Number of octets per frame per lane
5	0	0	0	K[4:0]					K = Number of frames per multiframe
6	M[7:0]								M = Number of converters per device
7	CS[1:0]		0	N[4:0]					CS = Number of control bits per sample N = Converter resolution
8	SUBCLASSV[2:0]			N_PRIME[4:0]					SUBCLASSV = Subclass version N_PRIME = Total bits per sample
9	JESDV[2:0]			S[4:0]					JESDV = JESD204 version S = Number of samples per converter per frame
10	HD	0	0	CF[4:0]					HD = High Density data format CF = Number of control words per frame clock per link
11	RES1[7:0]								RES1 = Reserved. Set to 8'h00
12	RES2[7:0]								RES2 = Reserved. Set to 8'h00
13	FCHK[7:0]								FCHK is the modulus 256 of the sum of the 13 configuration octets above.  For Intel Arria 10, Intel Cyclone 10 GX, Arria V, Cyclone V, and Stratix V devices, if you change any of the octets during run time, make sure to update the new FCHK value in the register.

<sup>(21)</sup> Applies to Subclass 2 only.



The JESD204B TX IP core also supports debug feature to continuously stay in ILAS phase without exiting. You can enable this feature by setting the bit in `csr_ilas_loop` register. There are two modes of entry:

- RX asserts `SYNC_N` and deasserts it after CGS phase. This activity triggers the ILAS phase and the CSR stays in ILAS phase indefinitely until this setting changes.
- Link reinitialization through CSR is initiated. The JESD204B IP core transmits `/K/` character and causes the RX converter to enter CGS phase. After RX deasserts `SYNC_N`, the CSR enters ILAS phase and stays in that phase indefinitely until this setting changes.

In ILAS loop, the multiframe transmission is the same where `/R/` character (K28.0) marks the start of multiframe and `/A/` character (K28.3) marks the end of multiframe, with dummy data in between. The dummy data is an increment of `Dx.y`.

#### 4.1.1.3. User Data Phase

During the user data phase, character replacement at the end of frame and end of multiframe is opportunistically inserted so that there is no additional overhead for data bandwidth.

##### Character replacement for non-scrambled data

The character replacement for non-scrambled mode in the IP core follows these JESD204B specification rules:

- At end of frame (not coinciding with end of multiframe), which equals the last octet in the previous frame, the transmitter replaces the octet with `/F/` character (K28.7). However, the original octet is encoded if an alignment character was transmitted in the previous frame.
- At the end of a multiframe, which equals to the last octet in the previous frame, the transmitter replaces the octet with `/A/` character (K28.3), even if a control character was already transmitted in the previous frame.

For devices that do not support lane synchronization, only `/F/` character replacement is done. At every end of frame, regardless of whether the end of multiframe equals to the last octet in previous frame, the transmitter encodes the octet as `/F/` character (K28.7) if it fits the rules above.

##### Character replacement for scrambled data

The character replacement for scrambled data in the IP core follows these JESD204B specification rules:

- At end of frame (not coinciding with end of multiframe), which equals to `0xFC` (D28.7), the transmitter encodes the octet as `/F/` character (K28.7).
- At end of multiframe, which equals to `0x7C`, the transmitter replaces the current last octet as `/A/` character (K28.3).

For devices that do not support lane synchronization, only `/F/` character replacement is done. At every end of frame, regardless of whether the end of multiframe equals to `0xFC` (D28.7), the transmitter encodes the octet as `/F/` character (K28.7) if it fits the rules above.

### 4.1.2. TX PHY Layer

The 8B/10B encoder encodes the data before transmitting them through the serial line. The 8B/10B encoding has sufficient bit transition density (3-8 transitions per 10-bit symbol) to allow clock recovery by the receiver. The control characters in this scheme allow the receiver to:

- synchronize to 10-bit boundary.
- insert special character to mark the start and end of frames and start and end of multiframe.
- detect single bit errors.

The JESD204B IP core supports transmission order from MSB first as well as LSB first. For MSB first transmission, the serialization of the left-most bit of 8B/10B code group (bit "a") is transmitted first.

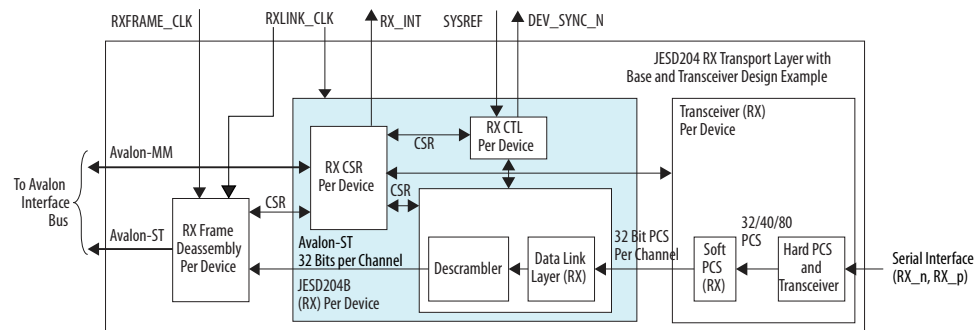
## 4.2. Receiver

The receiver block, which interfaces to ADC devices, receives the serial streams from one or more TX blocks and converts the streams into one or more sample streams.

The receiver performs the following functions:

- Data deserializer
- 8B/10B decoding
- Lane alignment
- Character replacement
- Data descrambling

**Figure 12. Receiver Data Path Block Diagram**



The receiver block includes the following modules:



- RX CSR—manages the configuration and status registers.
- RX\_CTL—manages the SYNC\_N signal, state machine that controls the data link layer states, LMFC, and also the buffer release, which is crucial for deterministic latency throughout the link.
- RX Scrambler and Data Link Layer—takes in 32 bits of data that decodes the ILAS, performs descrambling, character replacement as per the JESD204B specification, and error detection (code group error, frame and lane realignment error).

### 4.2.1. RX Data Link Layer

The JESD204B IP core RX data link layer buffers incoming user data on all lanes until the RX elastic buffers can be released. Special character substitution are done in the TX link so that the RX link can execute frame and lane alignment monitoring based on the JESD204B specification.

#### 4.2.1.1. RX CGS

The CGS phase is the link up phase that monitors the detection of /K28.5/ character.

The CGS phase is achieved through the following process:

- Once the word boundary is aligned, the RX PHY layer detects the /K28.5/ 20-bit boundary and indicate that the character is valid.
- The receiver deasserts SYNC\_N on the next frame boundary (for Subclass 0) or on the next LMFC boundary (for Subclass 1 and 2) after the reception of four successive /K/ characters.
- After correct reception of another four 8B/10B characters, the receiver assumes full code group synchronization. Error detected in this state machine is the code group error. Code group error always trigger link reinitialization through the assertion of SYNC\_N signal and this cannot be disabled through the CSR. The CS state machine is defined as CS\_INIT, CS\_CHECK, and CS\_DATA.
- The minimum duration for a synchronization request on the SYNC\_N is five frames plus nine octets.

#### 4.2.1.2. Frame Synchronization

After CGS phase, the receiver assumes that the first non-/K28.5/ character marks the start of frame and multiframe. If the transmitter emits an initial lane alignment sequence, the first non-/K28.5/ character is /K28.0/. Similar to the JESD204B TX IP core, the `csr_lane_sync_en` is set to 1 by default, thus the RX core detects the /K/ character to /R/ character transition. If the `csr_lane_sync_en` is set to 0, the RX core detects the /K/ character to the first data transition. An ILAS error and unexpected /K/ character is flagged if either one of these conditions are violated.

When `csr_lane_sync_en` is set to 0, you have to disable data checking for the first 16 octets of data as the character replacement block takes 16 octets to recover the end-of-frame pointer for character replacement. When `csr_lane_sync_en` is set to 1 (default JESD204B setting), the number of octets to be discarded depends on the scrambler or descrambler block.

The receiver assumes that a new frame starts in every F octets. The octet counter is used for frame alignment and lane alignment.

### Related Information

Scrambler/Descrambler on page 59

#### 4.2.1.3. Frame Alignment

The frame alignment is monitored through the alignment character /F/. The transmitter inserts this character at the end of frame. The /A/ character indicates the end of multiframe. The character replacement algorithm depends on whether scrambling is enabled or disabled, regardless of the `csr_lane_sync_en` register setting.

The alignment detection process:

- If two successive valid alignment characters are detected in the same position other than the assumed end of frame—without receiving a valid or invalid alignment character at the expected position between two alignment characters—the receiver realigns its frame to the new position of the received alignment characters.
- If lane realignment can result in frame alignment error, the receiver issues an error.

In the JESD204B RX IP core, the same flexible buffer is used for frame and lane alignment. Lane realignment gives a correct frame alignment because lane alignment character doubles as a frame alignment character. A frame realignment can cause an incorrect lane alignment or link latency. The course of action is for the RX to request for reinitialization through `SYNC_N`.<sup>(22)</sup>

#### 4.2.1.4. Lane Alignment

After the frame synchronization phase has entered `FS_DATA`, the lane alignment is monitored via /A/ character (/K28.3/) at the end of multiframe. The first /A/ detection in the ILAS phase is important for the RX core to determine the minimum RX buffer release for inter-lane alignment. There are two types of error that is detected in lane alignment phase:

- Arrival of /A/ character from multiple lanes exceed one multiframe.
- Misalignment detected during user data phase.

The realignment rules for lane alignment are similar to frame alignment:

- If two successive and valid /A/ characters are detected at the same position other than the assumed end of multiframe—without receiving a valid/invalid /A/ character at the expected position between two /A/ characters—the receiver aligns the lane to the position of the newly received /A/ characters.
- If a recent frame alignment causes the loss of lane alignment, the receiver realigns the lane frame—which is already at the position of the first received /A/ character—at the unexpected position.

---

(22) Dynamic frame realignment and correction is not supported.



#### 4.2.1.5. ILAS Data

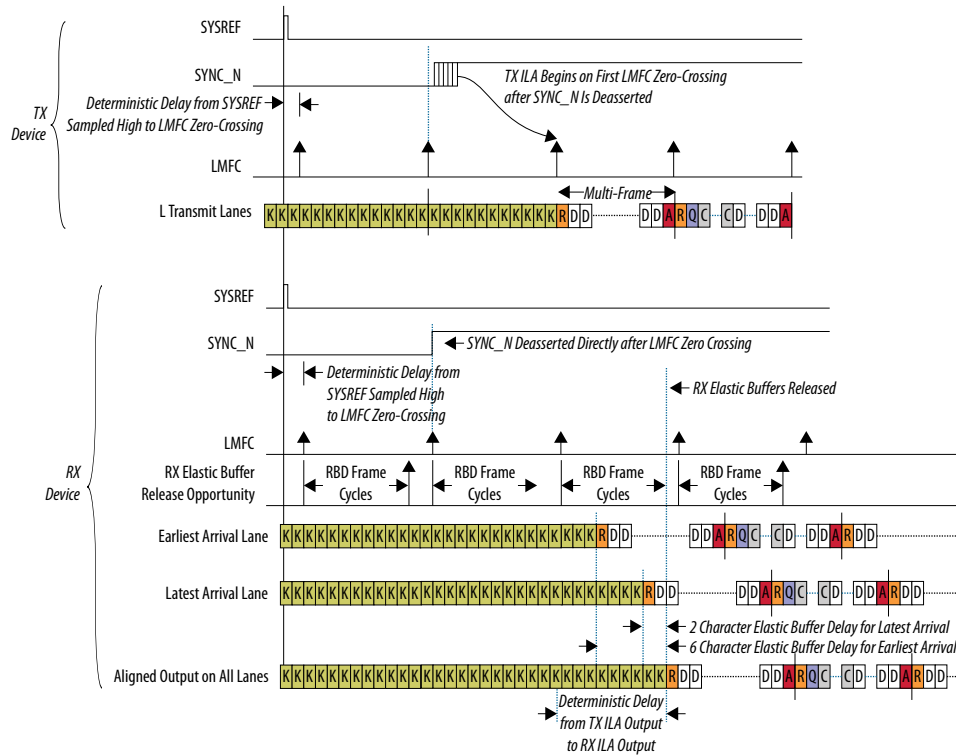
The JESD204B RX IP core captures 14 octets of link configuration data that are transmitted on the 2<sup>nd</sup> multiframe of the ILAS phase. The receiver waits for the reception of /Q/ character that marks the start of link configuration data and then latch it into ILAS octets, which are per lane basis. You can read the 14 octets captured in the link configuration data through the CSR. You need to first set the `csr_ilas_data_sel` register to select which link configuration data lane it is trying to read from. Then, proceed to read from the `csr_ilas_octet` register.

#### 4.2.1.6. Initial Lane Synchronization

The receivers in Subclass 1 and Subclass 2 modes store data in a memory buffer (Subclass 0 mode does not store data in the buffer but immediately releases them on the frame boundary as soon as the latest lane arrives.). The RX IP core detects the start of multiframe of user data per lane and then wait for the latest lane data to arrive. The latest data is reported as RBD count (`csr_rbd_count`) value which you can read from the status register. This is the earliest release opportunity of the data from the deskew FIFO (referred to as RBD offset).

The JESD204B RX IP core supports RBD release at 0 offset and also provides programmable offset through RBD count. By default, the RBD release can be programmed through the `csr_rbd_offset` to release at the LMFC boundary. If you want to implement an early release mechanism, program it in the `csr_rbd_offset` register. The `csr_rbd_offset` and `csr_rbd_count` is a counter based on the link clock boundary (not frame clock boundary). Therefore, the RBD release opportunity is at every four octets.

**Figure 13. Subclass 1 Deterministic Latency and Support for Programmable Release Opportunity**



### 4.2.2. RX PHY Layer

The word aligner block identifies the MSB and LSB boundaries of the 10-bit character from the serial bit stream. Manual alignment is set because the /K/ character must be detected in either LSB first or MSB first mode. When the programmed word alignment pattern is detected in the current word boundary, the PCS indicates a valid pattern in the `rx_sync_status` (mapped as `pcs_valid` to the IP core). The code synchronization state is detected after the detection of the /K/ character boundary for all lanes.

In a normal operation, whenever synchronization is lost, the JESD204B RX IP core always return back to the `CS_INIT` state where the word alignment is initiated. For debug purposes, you can bypass this alignment by setting the `csr_patternalign_en` register to 0.

The 8B/10B decoder decode the data after receiving the data through the serial line. The JESD204B IP core supports transmission order from MSB first as well as LSB first.

The PHY layer can detect 8B/10B not-in-table (NIT) error and also running disparity error.

### 4.3. Operation





### 4.3.1. Operating Modes

The JESD204B IP core supports Subclass 0, 1, and 2 operating modes.

#### 4.3.1.1. Subclass 0 Operating Mode

The JESD204B IP core maintains a LMFC counter that counts from 0 to  $(F \times K/4) - 1$  and wraps around again. The LMFC counter starts counting at the deassertion of *SYNC\_N* signal from multiple DACs after synchronization. This is to align the LMFC counter upon transmission and can only be done after all the converter devices have deasserted its synchronization request signal.

#### 4.3.1.2. Subclass 1 Operating Mode

The JESD204B IP core maintains a LMFC counter that counts from 0 to  $(F \times K/4) - 1$  and wraps around again. The LMFC counter resets within two link clock cycles after converter devices issue a common *SYSREF* frequency to all the transmitters and receivers. The *SYSREF* frequency must be the same for converter devices that are grouped and synchronized together.

**Table 21. Example of SYSREF Frequency Calculation**

In this example, you can choose to perform one of the following options:

- provide two *SYSREF* and device clock, where the ADC groups share both the device clock and *SYSREF* (18.75 MHz and 9.375 MHz)
- provide one *SYSREF* (running at 9.375 MHz) and device clock for all the ADC and DAC groups because the *SYSREF* period in the DAC is a multiplication of *n* integer.

Group	Configuration	SYSREF Frequency
ADC Group 1 (2 ADCs)	<ul style="list-style-type: none"> <li>• LMF = 222</li> <li>• K = 16</li> <li>• Data rate = 6 Gbps</li> </ul>	$(6 \text{ GHz} / 40) / (2 \times 16 / 4) = 18.75 \text{ MHz}$
ADC Group 2 (2 ADCs)	<ul style="list-style-type: none"> <li>• LMF = 811</li> <li>• K = 32</li> <li>• Data rate = 6 Gbps</li> </ul>	$(6 \text{ GHz} / 40) / (1 \times 32 / 4) = 18.75 \text{ MHz}$
DAC Group 3 (2 DACs)	<ul style="list-style-type: none"> <li>• LMF = 222</li> <li>• K = 16</li> <li>• Data rate = 3 Gbps</li> </ul>	$(3 \text{ GHz} / 40) / (2 \times 16 / 4) = 9.375 \text{ MHz}$

#### 4.3.1.3. Subclass 2 Operating Mode

The JESD204B IP core maintains a LMFC counter that counts from 0 to  $(F \times K/4) - 1$  and wraps around again. The LMFC count starts upon reset and the logic device always acts as the timing master. To support Subclass 2 for multi-link device, you must deassert the resets for all JESD204B IP core links synchronously at the same clock edge. This deassertion ensures that the internal LMFC counter is aligned across multi-link. The converters adjust their own internal LMFC to match the master's counter. The alignment of LMFC within the system relies on the correct alignment of *SYNC\_N* signal deassertion at the LMFC boundary.

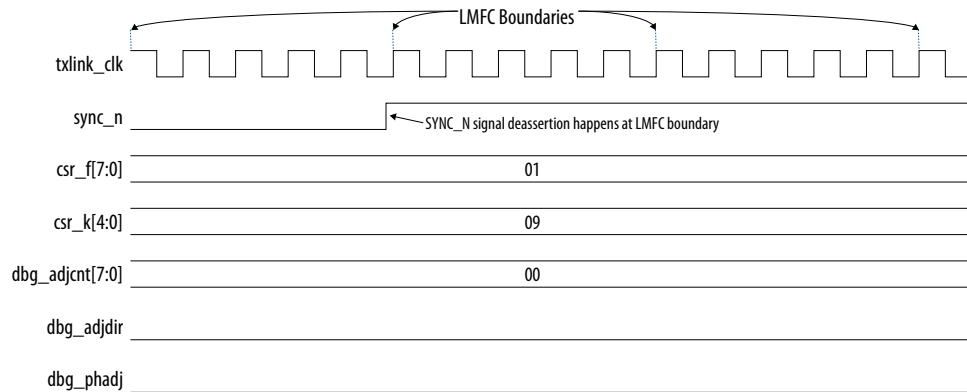
The alignment of LMFC to RX logic is handled within the TX converter. The RX logic releases *SYNC\_N* at the LMFC tick and the TX converter adjust its internal LMFC to match the RX LMFC.

For the alignment of LMFC to the TX logic, the JESD204B TX IP core samples SYNC\_N from the DAC receiver and reports the relative phase difference between the DAC and TX logic device LMFC in the TX CSR (dbg\_phadj, dbg\_adjdir, and dbg\_adjcnt). Based on the reported value, you can calculate the adjustment required. Then, to initiate the link reinitialization through the CSR, set the value in the TX CSR (csr\_phadj, csr\_adjdir, and csr\_adjcnt). The values on the phase adjustment are embedded in bytes 1 and 2 of the ILAS sequence that is sent to the DAC during link initialization. On the reception of the ILAS, the DAC adjusts its LMFC phase by step count value and sends back an error report with the new LMFC phase information. This process may be repeated until the LMFC at the DAC and the logic device are aligned.

**Table 22. dbg\_phadj, dbg\_adjdir and dbg\_adjcnt Values for Different SYNC\_N Deassertions**

Case	SYNC_N Signal Deassertion	dbg_phadj Value	dbg_adjdir Value	dbg_adjcnt Value
1	Happens at LMFC boundary <sup>(23)</sup>	0	—	—
2	Happens at LMFC count value that is equals or less than half of FxK/4 value	1	0	Number of link clock cycles from the LMFC boundary to the detection of SYNC_N signal deassertion
3	Happens at LMFC count value that is more than half of FxK/4 value	1	1	Number of link clock cycles from detection of the SYNC_N signal deassertion to the next LMFC boundary

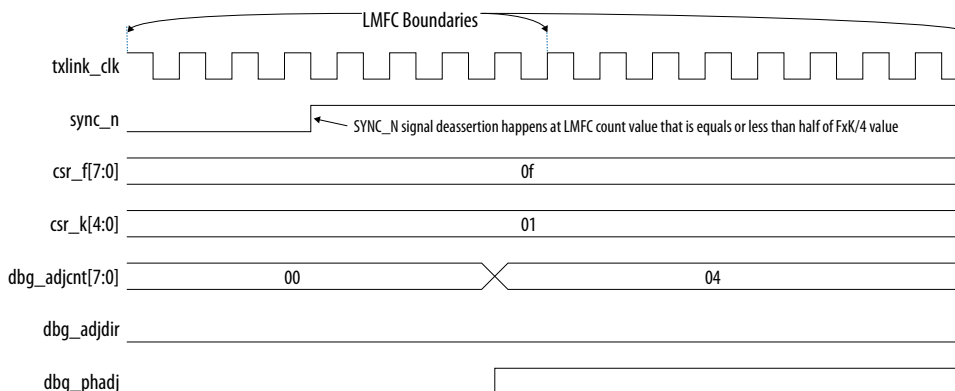
**Figure 14. Timing Diagram Example for Case 1**



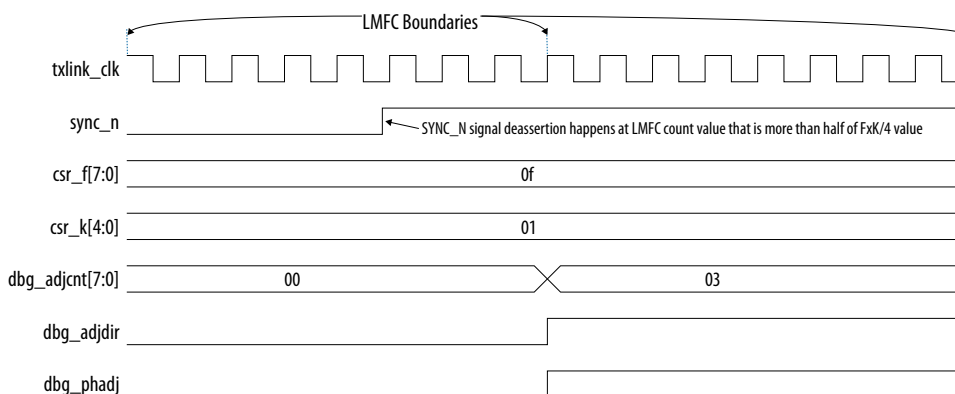
<sup>(23)</sup> No adjustment is required.



**Figure 15. Timing Diagram Example for Case 2**



**Figure 16. Timing Diagram Example for Case 3**



### 4.3.2. Scrambler/Descrambler

Both the scrambler and descrambler are designed in a 32-bit parallel implementation and the scrambling/descrambling order starts from first octet with MSB first.

The JESD204B TX and RX IP core support scrambling by implementing a 32-bit parallel scrambler in each lane. The scrambler and descrambler are located in the JESD204B IP MAC interfacing to the Avalon-ST interface. You can enable or disable scrambling and this option applies to all lanes. Mixed mode operation, where scrambling is enabled for some lanes, is not permitted.

The scrambling polynomial:

$$1 + x^{14} + x^{15}$$

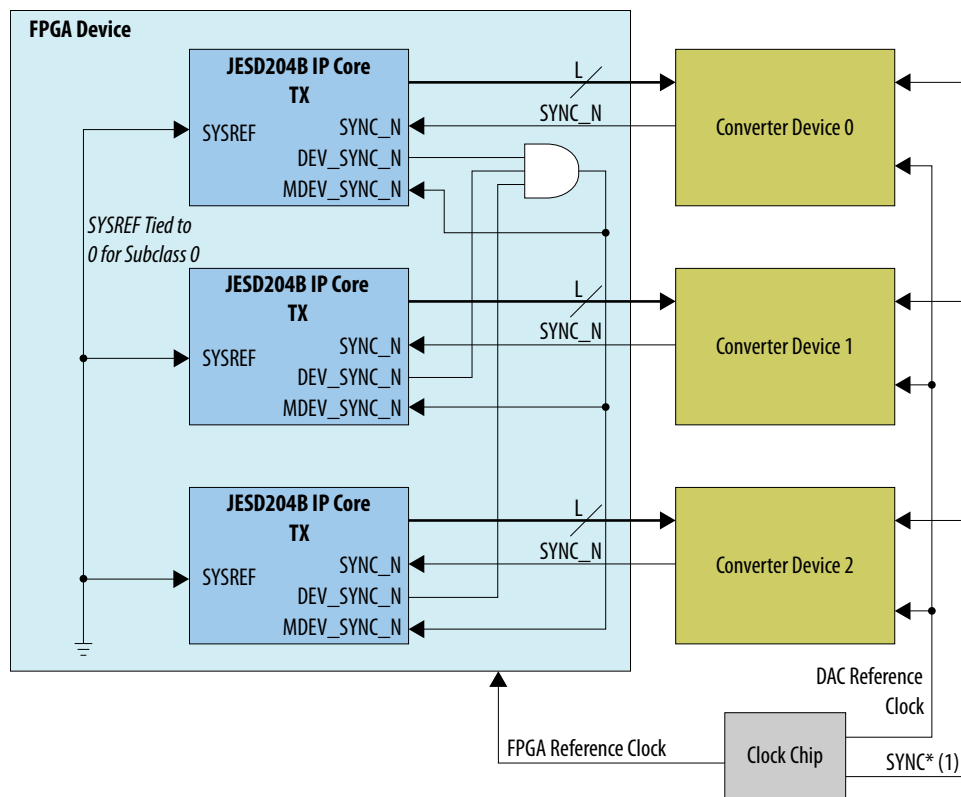
The descrambler can self-synchronize in eight octets. In a typical application where the reset value of the scrambler seed is different from the converter device to FPGA logic device, the correct user data is recovered in the receiver in two link clocks (due to the 32-bit architecture). The PRBS pattern checker on the transport layer should always disable checking of the first eight octets from the JESD204B RX IP core.

### 4.3.3. SYNC\_N Signal

For Subclass 0 implementation, the SYNC\_N signal from the DAC converters in the same group path must be combined.

In some applications, multiple converters are grouped together in the same group path to sample a signal (referred as multipoint link). The FPGA can only start the LMFC counter and its transition to ILAS after all the links deassert the synchronization request. The JESD204B TX IP core provides three signals to facilitate this application. The SYNC\_N is the direct signal from the DAC converters. The error signaling from SYNC\_N is filtered and sent out as dev\_sync\_n signal. For Subclass 0, you need to multiplex all the dev\_sync\_n signals in the same multipoint link and then input them to the IP core through mdev\_sync\_n signal.

**Figure 17. Subclass 0 – Combining the SYNC\_N Signal for JESD204B TX IP Core**



**Note:**

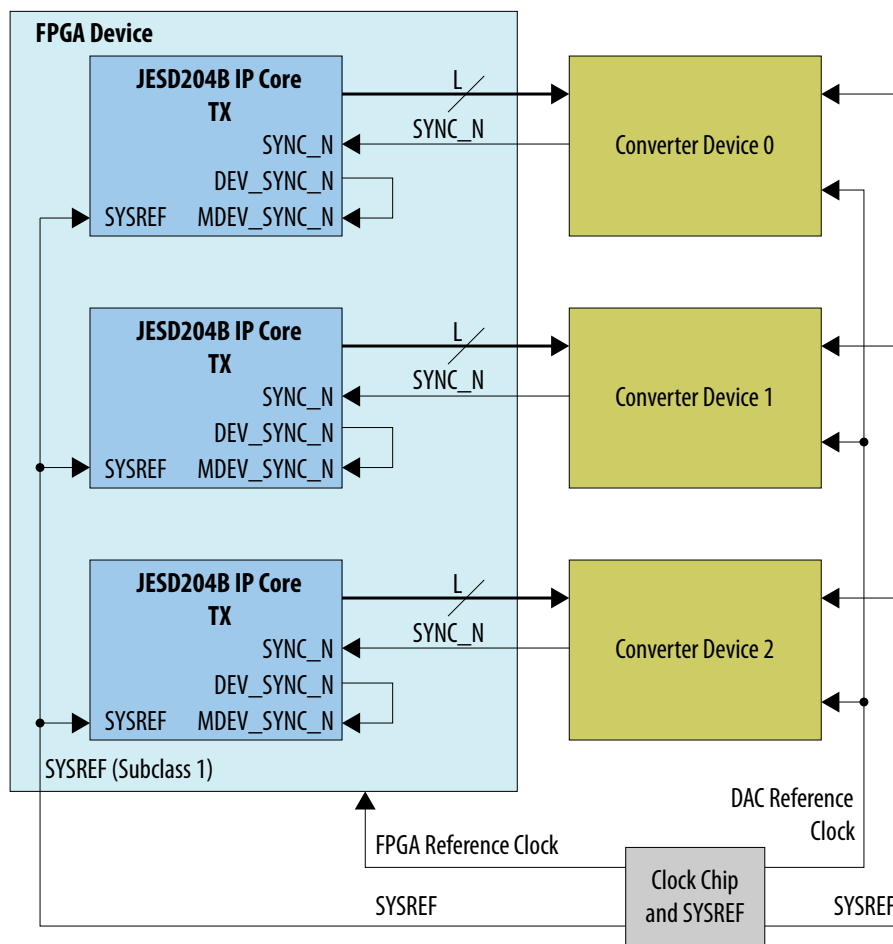
1. SYNC\* is not associated to SYNC\_N in the JESD204B specification. SYNC\* refers to JESD204A (Subclass 0) converter devices that may support synchronization via additional SYNC signalling.

For Subclass 1 implementation, you may choose to combine or not to combine the SYNC\_N signal from the converter device. If you implement two ADC converter devices as a multipoint link and one of the converter is unable to link up, the functional link still operates. You must manage the trace length for the SYSREF signal and also the differential pair to minimize skew.

The SYNC\_N is the direct signal from the DAC converters. The error signaling from SYNC\_N is filtered and sent out as dev\_sync\_n output signal. The dev\_sync\_n signal from the JESD204B TX IP core must loopback into the mdev\_sync\_n signal of the same instance without combining the SYNC\_N signal.

You must set the same RBD offset value (csr\_rbd\_offset) to all the JESD204B RX IP cores within the same multipoint link for the RBD release (the latest lane arrival for each of the links). The JESD204B RX IP core deskews and outputs the data when the RBD offset value is met. The total latency is consistent in the system and is also the same across multiple resets. Setting a different RBD offset to each link or setting an early release does not guarantee deterministic latency and data alignment.

**Figure 18. Subclass 1 – Combining the SYNC\_N Signal for JESD204B TX IP Core**



**Related Information**

Programmable RBD Offset on page 150

**4.3.4. Link Reinitialization**

The JESD204B TX and RX IP core support link reinitialization.

There are two modes of entry for link reinitialization:

- Hardware initiated link reinitialization:
  - For TX, the reception of `SYNC_N` for more than five frames and nine octets triggers link reinitialization.
  - For RX, the loss of code group synchronization, frame alignment and lane alignment errors cause the IP core to assert `SYNC_N` and request for link reinitialization.
- Software initiated link reinitialization—both the TX and RX IP core allow software to request for link reinitialization.
  - For TX, the IP core transmits /K/ character and wait for the receiver to assert `SYNC_N` to indicate that it has entered `CS_INIT` state.
  - For RX, the IP core asserts `SYNC_N` to request for link reinitialization.

Hardware initiated link reinitialization can be globally disabled through the `csr_link_reinit_disable` register for debug purposes.

Hardware initiated link reinitialization can be issued as interrupt depending on the error type and interrupt error enable. If lane misalignment has been detected as a result of a phase change in local timing reference, the software can rely on this interrupt trigger to initiates a LMFC realignment. The realignment process occurs by first resampling `SYSREF` and then issuing a link reinitialization request.

### 4.3.5. Link Startup Sequence

Set the run-time LMF configuration when the `txlink_rst_n` or `rxlink_rst_n` signals are asserted. Upon `txlink_rst_n` or `rxlink_rst_n` deassertion, the JESD204B IP core begins operation. The following sections describe the detailed operation for each subclass mode.

#### TX (Subclass 0)

Upon reset deassertion, the JESD204B TX IP core is in CGS phase. `SYNC_N` deassertion from the converter device enables the JESD204B TX IP core to exit CGS phase and enter ILAS phase (if `csr_lane_sync_en = 1`) or User Data phase (if `csr_lane_sync_en = 0`).

#### TX (Subclass 1)

Upon reset deassertion, the JESD204B TX IP core is in CGS phase. `SYNC_N` deassertion from the converter device enables the JESD204B TX IP core to exit CGS phase. The IP core ensures that at least one `SYSREF` rising edge is sampled before exiting CGS phase and entering ILAS phase. This is to prevent a race condition where the `SYNC_N` is deasserted before `SYSREF` is sampled. `SYSREF` sampling is crucial to ensure deterministic latency in the JESD204B Subclass 1 system.

#### TX (Subclass 2)

Similar to Subclass 1 mode, the JESD204B TX IP core is in CGS phase upon reset deassertion. The LMFC alignment between the converter and IP core starts after `SYNC_N` deassertion. The JESD204B TX IP core detects the deassertion of `SYNC_N` and compares the timing to its own LMFC. The required adjustment in the link clock domain is updated in the register map. You need to update the final phase adjustment



value in the registers for it to transfer the value to the converter during the ILAS phase. The DAC adjusts the LMFC phase and acknowledge the phase change with an error report. This error report contains the new DAC LMFC phase information, which allows the loop to iterate until the phase between them is aligned.

#### RX (Subclass 0)

The JESD204B RX IP core drives and holds `SYNC_N` (`dev_sync_n` signal) low when it is in reset. Upon reset deassertion, the JESD204B RX IP core checks if there is sufficient `/K/` character to move its state machine out of synchronization request. Once sufficient `/K/` character is detected, the IP core deasserts `SYNC_N`.

#### RX (Subclass 1)

The JESD204B RX IP core drives and holds the `SYNC_N` (`dev_sync_n` signal) low when it is in reset. Upon reset deassertion, the JESD204B RX IP core checks if there is sufficient `/K/` character to move its state machine out of synchronization request. The IP core also ensures that at least one `SYSREF` rising edge is sampled before deasserting `SYNC_N`. This is to prevent a race condition where the `SYNC_N` is deasserted based on internal free-running LMFC count instead of the updated LMFC count after `SYSREF` is sampled.

#### RX (Subclass 2)

The JESD204B RX IP core behaves the same as in Subclass 1 mode. In this mode, the logic device is always the master timing reference. Upon `SYNC_N` deassertion, the ADC adjusts the LMFC timing to match the IP core.

### 4.3.6. Error Reporting Through `SYNC_N` Signal

The JESD204B TX IP core can detect error reporting through `SYNC_N` when `SYNC_N` is asserted for two frame clock periods (if  $F \geq 2$ ) or four frame clock periods (if  $F = 1$ ). When the downstream device reports an error through `SYNC_N`, the TX IP core issues an interrupt. The TX IP core samples the `SYNC_N` pulse width using the link clock.

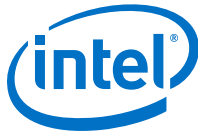
For a special case of  $F = 1$ , two frame clock periods are less than one link clock. Therefore, the error signaling from the receiver may be lost. You must program the converter device to extend the `SYNC_N` pulse to four frame clocks when  $F = 1$ .

The JESD204B RX IP core does not report an error through `SYNC_N` signaling. Instead, the RX IP core issues an interrupt when any error is detected.

You can check the `csr_tx_err`, `csr_rx_err0`, and `csr_rx_err1` register status to determine the error types.

## 4.4. Clocking Scheme

This section describes the clocking scheme for the JESD204B IP core and transceiver.



**Table 23. JESD204B IP Core Clocks**

Clock Signal	Formula	Description
TX/RX Device Clock: pll_ref_clk	PLL selection during IP core generation	The PLL reference clock used by the TX Transceiver PLL or RX CDR.  This is also the recommended reference clock to the PLL Intel FPGA IP core (for Arria V, Cyclone V, or Stratix V devices) or IOPLL Intel FPGA IP core (for Intel Arria 10, Intel Cyclone 10 GX, and Intel Stratix 10 devices).
TX/RX Link Clock: txlink_clk rxlink_clk	Data rate/40	The timing reference for the JESD204B IP core. The link clock runs at data rate/40 because the IP core operates in a 32-bit data bus architecture after 8B/10B encoding.  For Subclass 1, to avoid half link clock latency variation, you must supply the device clock at the same frequency as the link clock.  The JESD204B transport layer in the design example requires both the link clock and frame clock to be synchronous.
TX/RX Frame Clock (in design example): txframe_clk rxframe_clk	Data rate/(10 × F)	The frame clock as per the JESD204B specification. This clock is applicable to the JESD204B transport layer and other upstream devices that run in frame clock such as the PRBS generator/checker or any data processing blocks that run at the same rate as the frame clock.  The JESD204B transport layer in the design example also supports running the frame clock in half rate or quarter rate by using the <i>FRAMECLK_DIV</i> parameter. The JESD204B transport layer requires both the link clock and frame clock to be synchronous. For more information, refer to the F1/F2_FRAMECLK_DIV parameter description and its relationship to the frame clock in the respective JESD204B Intel FPGA IP design example user guides.
TX/RX Transceiver Serial Clock and Parallel Clock	Internally derived from the data rate during IP core generation	The serial clock is the bit clock to stream out serialized data. The transceiver PLL supplies this clock and is internal to the transceiver.  The parallel clock is for the transmitter PMA and PCS within the PHY. This clock is internal to the transceiver and is not exposed in the JESD204B IP core.  For Arria V, Cyclone V, and Stratix V devices, these clocks are internally generated as the transceiver PLL is encapsulated within the JESD204B IP core's PHY.  For Intel Arria 10, Intel Cyclone 10 GX, and Intel Stratix 10 L-tile and H-tile devices, you need to generate the transceiver PLL based on the data rate and connect the serial and parallel clock. You are recommended to select medium bandwidth for the transceiver PLL setting. These clocks are referred to as <i>*serial_clk</i> and <i>*bonding_clock</i> in Intel Arria 10, Intel Cyclone 10 GX, and Intel Stratix 10 L-tile and H-tile devices. Refer to the respective <i>Transceiver PHY IP Core User Guides</i> for more information.
TX/RX PHY Clock: txphy_clk rxphy_clk	Data rate/40 (for all devices except Arria V GT/ST in PMA Direct mode)  Data rate/80 (for Arria V GT/ST devices in PMA Direct mode)	The PHY clock generated from the transceiver parallel clock for the TX path or the recovered clock generated from the CDR for the RX path.  There is limited use for this clock. Avoid using this clock when PMA Direct mode is selected. Use this clock only if the JESD204B configuration is F=4 and the core is operating at Subclass 0 mode. This clock can be used as input for both the txlink_clk and txframe_clk, or rxlink_clk and rxframe_clk.  When you set the PCS option to enable Hard PCS or Soft PCS mode, the txphy_clk connects to the transceiver tx_std_clkout signal and the rxphy_clk connects to

**continued...**





Clock Signal	Formula	Description
		the <code>rx_std_clkout</code> signal. These are the clock lines at the PCS and FPGA fabric interface. When you enable PMA Direct mode (for Arria V GT/ST only), the <code>txphy_clk</code> connects to the transceiver <code>tx_pma_clkout</code> signal and the <code>rxphy_clk</code> connects to the <code>rx_pma_clkout</code> signal. These are the clock lines at the PMA and PCS interface.
TX/RX AVS Clock: <code>jesd204_tx_avs_clk</code> <code>jesd204_rx_avs_clk</code>	75–125 MHz	The configuration clock for the JESD204B IP core CSR through the Avalon-MM interface.
Transceiver Management Clock: <code>reconfig_clk</code>	100 MHz–125 MHz (Intel Arria 10) 100 MHz–125 MHz (Intel Cyclone 10 GX) 100 MHz–150 MHz (Intel Stratix 10)	The configuration clock for the transceiver CSR through the Avalon-MM interface. This clock is exported only when the transceiver dynamic reconfiguration option is enabled. This clock is only applicable for Intel Arria 10, Intel Cyclone 10 GX, and Intel Stratix 10 devices.

### Related Information

- [Design Examples for JESD204B IP Core User Guide](#)  
Provides information about design examples for Arria V, Cyclone V, Stratix V, and Intel Arria 10 devices using Intel Quartus Prime Standard Edition software.
- [JESD204B Intel Arria 10 FPGA IP Design Example User Guide](#)
- [JESD204B Intel Stratix 10 FPGA IP Design Example User Guide](#)
- [JESD204B Intel Cyclone 10 GX FPGA IP Design Example User Guide](#)
- [JESD204B Intel Agilex FPGA IP Design Example User Guide](#)

#### 4.4.1. Device Clock

In a converter device, the sampling clock is typically the device clock.

For the JESD204B IP in an FPGA logic device, you need one or two reference clocks as shown in [Figure 19](#) on page 66 and [Figure 20](#) on page 67. In the single reference clock design, the device clock is used as the transceiver PLL reference clock and also the core PLL reference clock. In the dual reference clock design, the device clock is used as the core PLL reference clock and the other reference clock is used as the transceiver PLL reference clock. The available frequency depends on the PLL type, bonding option, number of lanes, and device family. During IP core generation, the Intel Quartus Prime software recommends the available reference frequency for the transceiver PLL and core PLL based on user selection.

**Note:** Due to the clock network architecture in the FPGA, Intel recommends that you use the device clock to generate the link clock and use the link clock as the timing reference. You need to use the PLL Intel FPGA IP core (in Arria V, Cyclone V, and Stratix V devices) or IOPLL Intel FPGA IP core (in Intel Arria 10, Intel Cyclone 10 GX, and Intel Stratix 10 devices) to generate the link clock and frame clock. The link clock is used in the JESD204B IP (MAC) and the transport layer. You are recommended to supply the reference clock source through a dedicated reference clock pin.

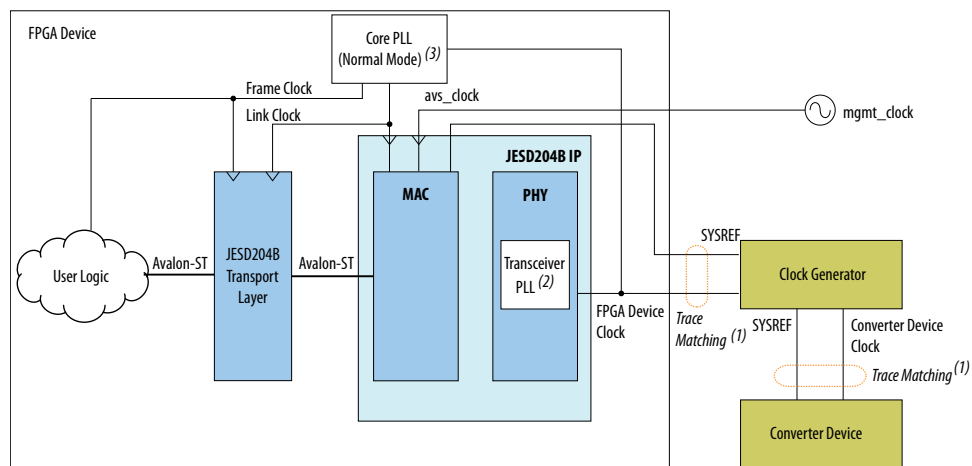
Based on the JESD204B specification for Subclass 1, the device clock is the timing reference and is source synchronous with `SYSREF`. To achieve deterministic latency, match the board trace length of the `SYSREF` signal with the device clock. Maintain a constant phase relationship between the device clock and `SYSREF` signal pairs going to the FPGA and converter devices. Ideally, the `SYSREF` pulses from the clock generator

should arrive at the FPGA and converter devices at the same time. To avoid half link clock latency variation, you must supply the device clock at the same frequency as the link clock.

The JESD204B protocol does not support rate matching. Therefore, you must ensure that the TX or RX device clock (`pll_ref_clk`) and the PLL reference clock that generates link clock (`txlink_clk` or `rxlink_clk`) and frame clock (`txframe_clk` or `rxframe_clk`) have 0 ppm variation. Both PLL reference clocks should come from the same clock chip.

**Figure 19. JESD204B Subsystem with Shared Transceiver Reference Clock and Core Clock**

*Note:* This diagram is not applicable for Intel Agilex and Intel Stratix 10 E-tile devices.

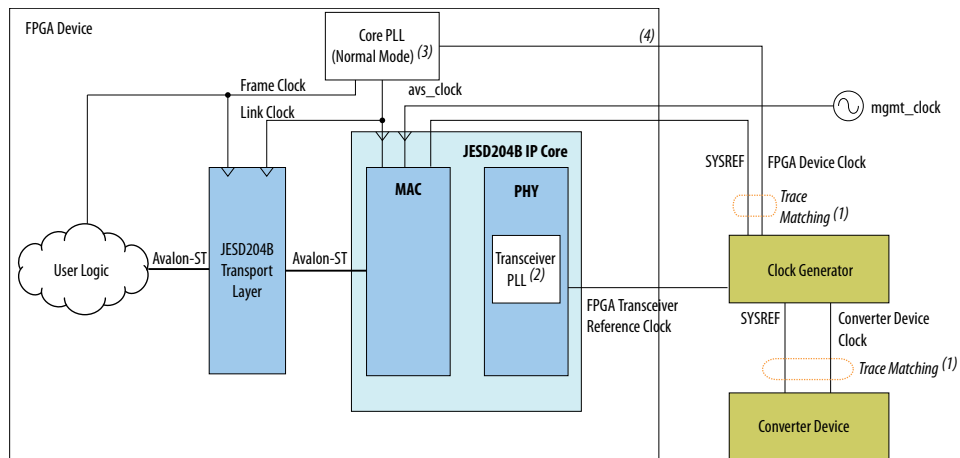


**Notes:**

1. The device clock to the Intel core PLL and SYSREF must be trace matched. The device clock to the converter device and SYSREF must be trace matched. The phase offset between the SYSREF to the FPGA and converter devices should be minimal.
2. For Intel Arria 10, Intel Cyclone 10 GX, and Intel Stratix 10 L-tile and H-tile devices, the transceiver PLL is outside of the JESD204B IP. For Arria V, Cyclone V, and Stratix V devices, the transceiver PLL is part of the JESD204B IP.
3. The core PLL provides the link clock and frame clock. The link clock and frame clock must be synchronous. The AVS clock (e.g. `mgmt_clk`) can be asynchronous to the link and frame clock.



**Figure 20. JESD204B Subsystem with Separate Transceiver Reference Clock and Core Clock**



- Notes:**
1. The device clock to the Intel core PLL and SYSREF must be trace matched. The device clock to the converter device and SYSREF must be trace matched. The phase offset between the SYSREF to the FPGA and converter devices should be minimal.
  2. For Intel Arria 10, Intel Cyclone 10 GX, and Intel Stratix 10 L-tile and H-tile devices, the transceiver PLL is outside of the JESD204B IP core. For Arria V, Cyclone V, Stratix V, and Intel Stratix 10 E-tile devices, the transceiver PLL is part of the JESD204B IP core.
  3. The core PLL provides the link clock and frame clock. The link clock and frame clock must be synchronous. The AVS clock (e.g. mgmt\_clk) can be asynchronous to the link and frame clock.
  4. You must use a dedicated reference clock input for the core PLL to compensate the FPGA clock network latency. This ensures that SYSREF is captured without any cycle variation.

**Related Information**

[Clock Correlation](#) on page 69

**4.4.2. Link Clock**

The device clock is the timing reference for the JESD204B system.

Due to the clock network architecture in the FPGA, JESD204B IP core does not use the device clock to clock the SYSREF signal because the GCLK or RCLK is not fully compensated. You are recommended to use the PLL Intel FPGA IP core (in Arria V, Cyclone V, and Stratix V devices) or IOPLL Intel FPGA IP core (in Intel Arria 10, Intel Cyclone 10 GX, and Intel Stratix 10 devices) to generate both the link clock and frame clock. The PLL Intel FPGA IP core must operate in **normal mode** or **source synchronous mode** and uses a dedicated reference clock pin as the input reference clock source to achieve the following state:

- the GCLK and RCLK clock network latency is fully compensated.
- the link clock and frame clock at the registers are phase-aligned to the input of the clock pin.

To provide consistency across the design regardless of frame clock and sampling clock, the link clock is used as a timing reference.

The PLL Intel FPGA IP core should provide both the frame clock and link clock from the same PLL as these two clocks are treated as synchronous in the design.

For Subclass 0 mode, the device clock is not required to sample the SYSREF signal edge. The link clock does not need to be phase compensated to capture SYSREF. Therefore, you can generate both the link clock and frame clock using direct mode in

the PLL Intel FPGA IP core. If  $F = 4$ , where link clock is the same as the frame clock, you can use the parallel clock output from the transceiver (`txphy_clk` or `rxphy_clk` signal) except when the PCS option is in PMA Direct mode.

#### Related Information

[Clock Correlation](#) on page 69

### 4.4.3. Local MultiFrame Clock

The Local MultiFrame Clock (LMFC) is a counter generated from the link clock and depends on the  $F$  and  $K$  parameter.

The  $K$  parameter must be set between 1 to 32 and meet the requirement of at least a minimum of 17 octets and a maximum of 1024 octets in a single multiframe. In a 32-bit architecture, the  $K \times F$  must also be in the order of four.

In a Subclass 1 deterministic latency system, the *SYSREF* frequency is distributed to the devices to align them in the system. The *SYSREF* resets the internal LMFC clock edge when the sampled *SYSREF* signal's rising edge transition from 0 to 1. Due to source synchronous signaling of *SYSREF* with respect to the device clock sampling (provided from the clock chip), the JESD204B IP core does not directly use the device clock to sample *SYSREF* but instead uses the link clock to sample *SYSREF*. Therefore, the Intel FPGA PLL IP core that provides the link clock must be in **normal mode** to phase-compensate the link clock to the device clock.

Based on hardware testing, to get a fixed latency, at least 32 octets are recommended in an LMFC period so that there is a margin to tune the RBD release opportunity to compensate any lane-to-lane deskew across multiple resets. If  $F = 1$ , then  $K = 32$  is optimal as it provides enough margin for system latency variation. If  $F = 2$ , then  $K = 16$  and above (18/20/22/24/26/28/30/32) is sufficient to compensate lane-to-lane deskew.

The JESD204B IP core implements the local multiframe clock as a counter that increments in link clock counts. The local multiframe clock counter is equal to  $(F \times K/4)$  in link clock as units. The rising edge of *SYSREF* resets the local multiframe clock counter to 0. There are two CSR bits that controls *SYSREF* sampling.

- `csr_sysref_singledet`—resets the local multiframe clock counter once and automatically cleared after *SYSREF* is sampled. This register also prevents CGS exit to bypass *SYSREF* sampling.
- `csr_sysref_alwayson`—resets the local multiframe clock counter at every rising edge of *SYSREF* that it detects. This register also enables the *SYSREF* period checker. If the provided *SYSREF* period violates the  $F$  and  $K$  parameter, an interrupt is triggered. However, this register does not prevent CGS-*SYSREF* race condition.

The following conditions occur if both CSR bits are set:

- resets the local multiframe clock counter at every rising edge of *SYSREF*.
- prevents CGS-*SYSREF* race condition.
- checks *SYSREF* period.

#### Related Information

[Clock Correlation](#) on page 69



#### 4.4.4. Clock Correlation

This section describes the clock correlation between the device clock, link clock, frame clock, and local multiframe clock.

##### Example 1

Targeted Device with LMF=222, K=16 and Data rate = 6.5 Gbps

Device Clock Selected = 325 MHz (obtained during IP core generation)

Link Clock =  $6.5 \text{ GHz}/40 = 162.5 \text{ MHz}$

Frame Clock =  $6.5 \text{ GHz}/(10 \times 2) = 325 \text{ MHz}$

Local Multiframe Clock =  $325 \text{ MHz} / 16 = 20.3125 \text{ MHz}$

SYSREF Frequency = Local Multiframe Clock / n; (n = integer; 1, 2, ...)

Local Multiframe Clock Counter =  $(F \times K/4) = (2 \times 16/4) = 8 \text{ link clocks}$  <sup>(24)</sup>

##### Example 2

Targeted Device with LMF=244, K=16 and Data rate = 5.0 Gbps

Device Clock Selected = 125 MHz (obtained during IP core generation)

Link Clock =  $5 \text{ GHz}/40 = 125 \text{ MHz}$  <sup>(25)</sup>

Frame Clock =  $5 \text{ GHz} / (10 \times 4) = 125 \text{ MHz}$  <sup>(25)</sup>

Local Multiframe Clock =  $125 \text{ MHz} / 16 = 7.8125 \text{ MHz}$

SYSREF Frequency = Local Multiframe Clock / n; (n = integer; 1, 2, ...)

Local Multiframe Clock Counter =  $(F \times K/4) = (4 \times 16/4) = 16 \text{ link clocks}$  <sup>(24)</sup>

##### Example 3

Targeted Device with LMF=421, K=32 and Data rate = 10.0 Gbps

Device Clock Selected = 250 MHz (obtained during IP core generation)

Link Clock =  $10 \text{ GHz}/40 = 250 \text{ MHz}$

Frame Clock =  $10 \text{ GHz}/(10 \times 1) = 1 \text{ GHz}$  <sup>(26)</sup>

---

<sup>(24)</sup> Eight link clocks mean that the local multiframe clock counts from values 0 to 7 and then loops back to 0.

<sup>(25)</sup> The link clock and frame clock are running at the same frequency. You only need to generate one clock from the Intel FPGA PLL or Intel FPGA IO PLL IP core.

<sup>(26)</sup> In this example, the frame clock may not be able to run up to 1 GHz in the FPGA fabric. The JESD204B transport layer in the design example supports running the data stream of half rate ( $1 \text{ GHz}/2 = 500 \text{ MHz}$ ), at two times the data bus width or of quarter rate ( $1 \text{ GHz}/4 = 250 \text{ MHz}$ ), at four times the data bus width.



Local Multiframe Clock = 1 GHz / 32 = 31.25 MHz

SYSREF Frequency = Local Multiframe Clock / n; (n = integer; 1, 2, ...)

Local Multiframe Clock Counter = (F × K/4) = (1×32/4) = 8 link clocks <sup>(24)</sup>

**Example 4 (When F=3, for Intel Stratix 10 devices only)**

Targeted Device with LMF=883, K=32 and Data rate = 12.0 Gbps

Device Clock Selected = 300 MHz (obtained during IP core generation)

Link Clock = 12 GHz/40 = 300 MHz

Frame Clock = 12 GHz/(10×3) = 400 MHz <sup>(27)</sup>

Local Multiframe Clock = 400 MHz / 32 = 12.5 MHz

SYSREF Frequency = Local Multiframe Clock / n; (n = integer; 1, 2, ...)

Local Multiframe Clock Counter = (F × K/4) = (3×32/4) = 24 link clocks <sup>(24)</sup>

**Related Information**

- [Device Clock](#) on page 65
- [Link Clock](#) on page 67
- [Local MultiFrame Clock](#) on page 68

## 4.5. Reset Scheme

All resets in the JESD204B IP are synchronous reset signals and should be asserted and deasserted synchronously.

**Note:** Ensure that the resets are synchronized to the respective clocks for reset assertion and deassertion.

**Table 24. JESD204B IP Resets**

Reset Signal	Associated Clock	Description
txlink_rst_n rxlink_rst_n	TX/RX Link Clock	Active low reset. Intel recommends that you: <ul style="list-style-type: none"> <li>• Assert the txlink_rst_n/rxlink_rst_n and txframe_rst_n/rxframe_rst_n signals when the transceiver is in reset.</li> <li>• Deassert the txlink_rst_n and txframe_rst_n signals after the Intel FPGA PLL IP is locked and the tx_ready[] signal from the Transceiver Reset Controller is asserted.</li> <li>• Deassert the rxlink_rst_n and rxframe_rst_n signals after the Transceiver CDR rx_islockedto data[] signal and rx_ready[] signal from the Transceiver Reset Controller are asserted.</li> </ul>

*continued...*

<sup>(27)</sup> The JESD204B transport layer in the design example runs the data stream at half rate (400 MHz/2 = 200 MHz), two times the data bus width.



Reset Signal	Associated Clock	Description
		The txlink_rst_n/rxlink_rst_n and txframe_rst_n/rxframe_rst_n signals can be deasserted at the same time. These resets can only be deasserted after you configure the CSR registers.
txframe_rst_n rxframe_rst_n	TX/RX Frame Clock	Active low reset controlled by the clock and reset unit. If the TX/RX link clock and the TX/RX frame clock has the same frequency, both can share the same reset.
tx_analogreset[L-1:0] rx_analogreset[L-1:0]	Transceiver Native PHY Analog Reset	Active high reset controlled by the transceiver reset controller. This signal resets the TX/RX PMA. The link clock, frame clock, and AVS clock reset signals (txlink_rst_n/rxlink_rst_n, txframe_rst_n/rxframe_rst_n and jesd204_tx_avs_rst_n/jesd204_rx_avs_rst_n) can only be deasserted after the transceiver comes out of reset. <sup>(28)</sup> <i>Note:</i> This signal is not applicable for Intel Agilex and Intel Stratix 10 E-tile devices.
tx_analogreset_stat[L-1:0] rx_analogreset_stat[L-1:0]	Transceiver Native PHY Analog Reset	TX PMA analog reset status port connected to the transceiver reset controller. <sup>(29)</sup> <i>Note:</i> This signal is applicable only for Intel Stratix 10 L-tile and H-tile devices.
tx_digitalreset[L-1:0] rx_digitalreset[L-1:0]	Transceiver Native PHY Digital Reset	Active high reset controlled by the transceiver reset controller. This signal resets the TX/RX PCS. The link clock, frame clock, and AVS clock reset signals (txlink_rst_n/rxlink_rst_n, txframe_rst_n/rxframe_rst_n and jesd204_tx_avs_rst_n/jesd204_rx_avs_rst_n) can only be deasserted after the transceiver comes out of reset. <sup>(28)</sup> <i>Note:</i> This signal is not applicable for Intel Agilex and Intel Stratix 10 E-tile devices.
tx_digitalreset_stat[L-1:0] rx_digitalreset_stat[L-1:0]	Transceiver Native PHY Digital Reset	TX PCS digital reset status port connected to the transceiver reset controller. <sup>(29)</sup> <i>Note:</i> This signal is applicable only for Intel Stratix 10 L-tile and H-tile devices.
jesd204_tx_avs_rst_n jesd204_rx_avs_rst_n	TX/RX AVS (CSR) Clock	Active low reset controlled by the clock and reset unit. Typically, both signals can be deasserted after the core PLL and transceiver PLL are locked and out of reset. If you want to dynamically modify the LMF at run-time, you can program the CSRs after AVS reset is deasserted. This phase is referred to as the configuration phase. After the configuration phase is complete, then only the txlink_rst_n/rxlink_rst_n and txframe_rst_n/rxframe_rst_n signals can be deasserted.

#### Related Information

- [V-Series Transceiver PHY User Guide](#)

<sup>(28)</sup> Refer to the *respective Transceiver PHY IP User Guides* for the timing diagram of the tx\_analogreset, rx\_analogreset, tx\_digitalreset, and rx\_digitalreset signals.

<sup>(29)</sup> Refer to the *Intel Stratix 10 L- and H-tile Transceiver PHY IP User Guide* for the timing diagram of the tx\_analogreset\_stat, rx\_analogreset\_stat, tx\_digitalreset\_stat, and rx\_digitalreset\_stat signals.

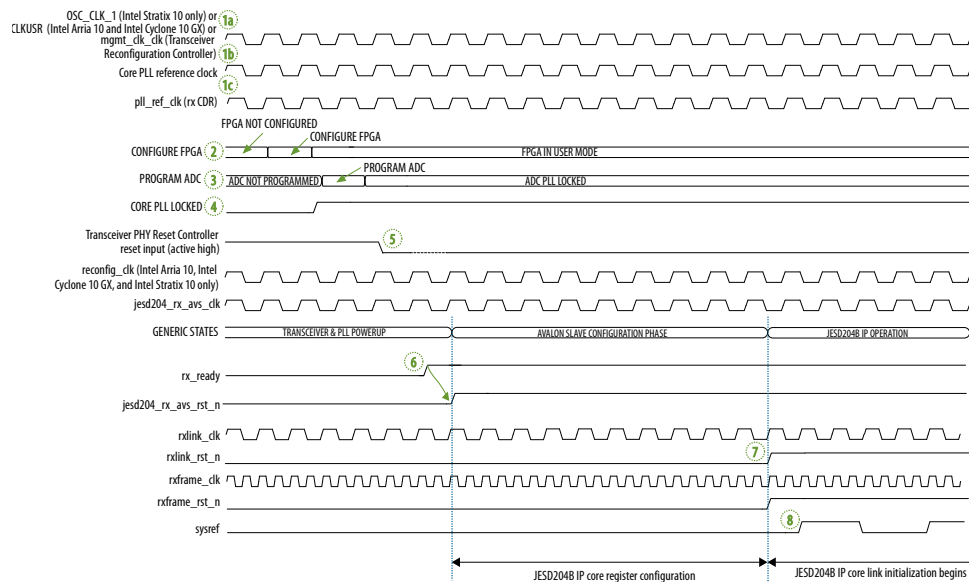
- Intel Arria 10 Transceiver PHY User Guide
- Intel Cyclone 10 GX Transceiver PHY User Guide
- Intel Stratix 10 L- and H-tile Transceiver PHY User Guide
- E-tile Transceiver PHY User Guide

### 4.5.1. Reset Sequence

Intel recommends that you assert reset for the JESD204B IP core and transport layer when powering up the PLLs and transceiver.

### 4.5.2. ADC-FPGA Subsystem Reset Sequence

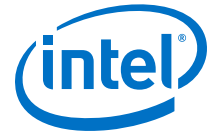
Figure 21. ADC-FPGA Subsystem Reset Sequence Timing Diagram



The recommended ADC – FPGA subsystem bring-up sequence:

1. Provide a free-running and stable reference clock to the converter and FPGA in the JESD204B subsystem. The reference clock for the converter is the device clock. Intel recommends four reference clocks for the FPGA.
  - a. The first reference clock is the calibration clock for the transceiver.
    - For Intel Stratix 10 devices, this is the clock at the OSC\_CLK\_1 pin for the calibration engine.
    - For Intel Arria 10 and Intel Cyclone 10 GX devices, this is the clock at the CLKUSR pin for the calibration engine.
    - For Arria V, Cyclone V, and Stratix V devices, this is the clock for the transceiver reconfiguration controller.
  - b. The second reference clock is the management clock for the transceiver reconfiguration interface and the JESD204B IP core Avalon-MM interface.





- If the dynamic reconfiguration option is enabled for Intel Arria 10, Intel Cyclone 10 GX, and Intel Stratix 10 devices, this reference clock is connected to the `reconfig_clk` input port of the JESD204B IP core.
- c. The third reference clock is the transceiver reference clock.
    - For Intel Stratix 10, you must provide the reference clock at the transceiver dedicated reference clock input pin.
    - For Intel Arria 10, Intel Cyclone 10 GX, Arria V, Cyclone V, and Stratix V devices, this clock is also used as the reference clock for the core PLL (IOPLL Intel FPGA IP core for Intel Arria 10 and Intel Cyclone 10 GX devices; and PLL Intel FPGA IP core for Arria V, Cyclone V, and Stratix V devices) if you share the device clock and the transceiver reference clock (refer to [Figure 19](#) on page 66).
  - d. The fourth reference clock is the core PLL reference clock (device clock).
    - For Intel Stratix 10, you must provide the reference clock at the dedicated reference clock input pin at the IO bank.
    - For Intel Arria 10, Intel Cyclone 10 GX, Arria V, Cyclone V, and Stratix V devices, this is the reference clock for the core PLL (IOPLL Intel FPGA IP core for Intel Arria 10 and Intel Cyclone 10 GX devices; and PLL Intel FPGA IP core for Arria V, Cyclone V, and Stratix V devices) if you do not share the device clock and the transceiver reference clock (refer to [Figure 19](#) on page 66).
2. Configure the FPGA. Hold the RX transceiver channel in reset.
    - For Intel Arria 10 and Intel Cyclone 10 GX devices, if the reference clock is not available for the transceiver CDR before the FPGA is configured, you need to hold the RX transceiver channels in reset and perform user calibration for the RX transceiver channels after the reference clock is stable. For more information about user calibration for the transceiver channels, refer to the Calibration chapter in the *Intel Arria 10 or Intel Cyclone 10 GX Transceiver PHY User Guides*.
  3. You can program the ADC through its SPI interface before or after configuring the FPGA. Ensure that the ADC PLL is locked before you proceed to the next step.
  4. Ensure that the FPGA device clock core PLL is locked to the reference clock.
  5. Deassert the FPGA RX transceiver channel reset. Do this by deasserting the reset input pin of the Transceiver PHY Reset Controller.
  6. Once the transceiver is out of reset (the `rx_ready` signal from the Intel FPGA Transceiver PHY Reset Controller is asserted), deassert the Avalon-MM interface reset for the IP core. At the configuration phase, the subsystem can program the JESD204B IP core if the default IP core register settings need to change.
  7. Deassert both the link reset for the IP core and the frame reset for the transport layer.
  8. For subclass 1, if the continuous `SYSREF` pulses from the clock generator are present when the RX link reset is deasserted, the ADC-RX link initializes. If the `SYSREF` pulse is not present, trigger the clock generator to provide a `SYSREF` pulse to initialize the link. For subclass 0, the link initializes after the ADC is programmed and the RX link reset is deasserted.

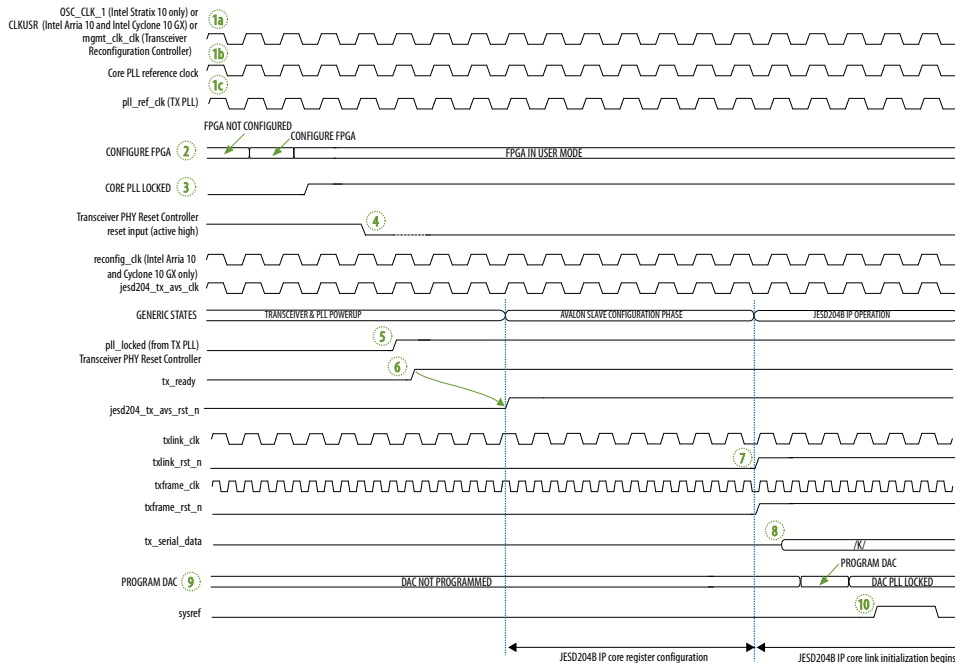
#### Related Information

- [V-Series Transceiver PHY User Guide](#)

- Intel Arria 10 Transceiver PHY User Guide
- Intel Cyclone 10 GX Transceiver PHY User Guide
- Intel Stratix 10 L- and H-tile Transceiver PHY User Guide
- E-tile Transceiver PHY User Guide

### 4.5.3. FPGA–DAC Subsystem Reset Sequence

Figure 22. FPGA–DAC Subsystem Reset Sequence Timing Diagram



The recommended FPGA – DAC subsystem bring-up sequence:

1. Provide a free-running and stable reference clock to the converter and FPGA in the JESD204B subsystem. The reference clock for the converter is the device clock. Intel recommends four reference clocks for the FPGA.
  - a. The first reference clock is the calibration clock for the transceiver.
    - For Intel Stratix 10 devices, this is the clock at the OSC\_CLK\_1 pin for the calibration engine.
    - For Intel Arria 10 and Intel Cyclone 10 GX devices, this is the clock at the CLKUSR pin for the calibration engine.
    - For Stratix V, Arria V, and Cyclone V devices, this is the clock for the transceiver reconfiguration controller.
  - b. The second reference clock is the management clock for the transceiver reconfiguration interface and the JESD204B IP core Avalon MM interface.
    - If the dynamic reconfiguration option is enabled for Intel Arria 10, Intel Cyclone 10 GX, and Intel Stratix 10 devices, this reference clock is connected to the reconfig\_clk input port of the JESD204B IP core.
  - c. The third reference clock is the transceiver reference clock.



- For Intel Stratix 10, you must provide the reference clock at the transceiver dedicated reference clock input pin.
  - For Intel Arria 10, Intel Cyclone 10 GX, Arria V, Cyclone V, and Stratix V, this clock is also used as the reference clock for the core PLL (IOPLL Intel FPGA IP core for Intel Arria 10 and Intel Cyclone 10 GX; and PLL Intel FPGA IP core for Arria V, Cyclone V, and Stratix V devices) if you share the device clock and the transceiver reference clock (refer to [Figure 19](#) on page 66).
- d. The fourth reference clock is the core PLL reference clock (device clock).
- For Intel Stratix 10, you must provide the reference clock at the dedicated reference clock input pin at the IO bank.
  - For Intel Arria 10, Intel Cyclone 10 GX, Arria V, Cyclone V, and Stratix V, this is the reference clock for the core PLL (IOPLL Intel FPGA IP core for Intel Arria 10 and Intel Cyclone 10 GX devices; and PLL Intel FPGA IP core for Arria V, Cyclone V, and Stratix V devices) if you do not share the device clock and the transceiver reference clock (refer to [Figure 20](#) on page 67).
2. Configure the FPGA. Hold the TX transceiver PLL and channel in reset.
- For Intel Arria 10 and Intel Cyclone 10 GX devices, if the reference clock is not available for the transceiver PLL before the FPGA is configured, you need to hold the transceiver PLL and channels in reset and perform user calibration for the transceiver PLL and TX channels after the reference clock is stable. For more information about user calibration for the transceiver PLL and channels, refer to the *Calibration* chapter in the *Intel Arria 10 or Intel Cyclone 10 GX Transceiver PHY User Guides*.
3. Ensure that the FPGA device clock core PLL is locked to the reference clock.
4. Deassert the FPGA TX transceiver PLL and channel reset. Do this by deasserting the reset input pin of the Transceiver PHY Reset Controller.
5. Ensure that the FPGA transceiver PLL is locked to the reference clock.
6. Once the TX transceiver PLL and channel are out of reset (the `tx_ready` signal from the Transceiver PHY Reset Controller is asserted), deassert the Avalon-MM interface reset for the IP core. At the configuration phase, the subsystem can program the JESD204B IP core if the default IP core register settings need to change.
7. Deassert both the link reset for the IP core and the frame reset for the transport layer.
8. The TX IP core streams /K/ characters to the DAC after TX link reset is deasserted.
9. Program the DAC through its SPI interface.
10. For subclass 1, if the continuous `SYSREF` pulses from the clock generator are present when the TX link reset is deasserted, the TX-DAC link initializes. If the `SYSREF` pulse is not present, trigger the clock generator to provide a `SYSREF` pulse to initialize the link.
11. For subclass 0, the link initializes after the DAC is programmed and the TX link reset is deasserted.



## 4.6. Signals

The JESD204B IP core signals are listed by interface:

- Transmitter
- Receiver

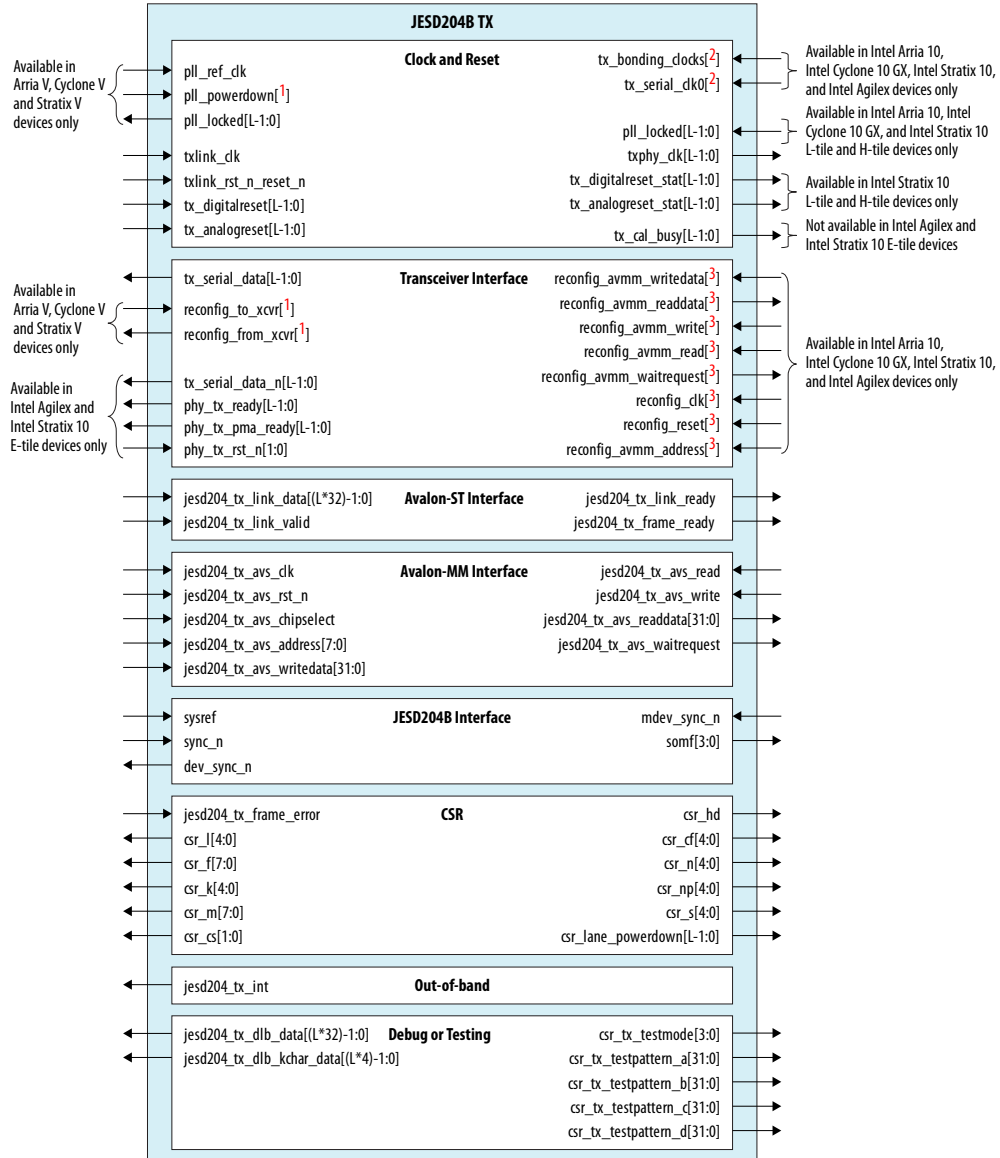
*Note:* You should terminate any unused signals.



### 4.6.1. Transmitter Signals

Figure 23. Transmitter Signal Diagram

L denotes the number of lanes.



- Note:
1. Refer to the *Transmitter Signals* table for actual signal width.
  2. Refer to the *Transmitter Signals* table for actual signal name.
  3. Refer to the *Transmitter Signals* table for actual signal width and name.



**Table 25. Transmitter Signals**

Signal	Width	Direction	Description
<b>Clocks and Resets</b>			
pll_ref_clk	1	Input	Transceiver reference clock signal. The reference clock selection depends on the FPGA device family and data rate. This signal is only applicable for Arria V, Cyclone V, and Stratix V devices.
txlink_clk	1	Input	TX link clock signal. This clock is equal to the TX data rate divided by 40. For Subclass 1, you cannot use the output of txphy_clk signal as txlink_clk signal. To sample SYSREF correctly, the core PLL must provide the txlink_clk signal and must be configured as normal operating mode.
txlink_rst_n_reset_n	1	Input	Reset for the TX link clock signal. This reset is an active low signal.
txphy_clk[]	L	Output	TX parallel clock output for the TX transceiver with PCS option in Hard PCS or Soft PCS mode. This clock has the same frequency as txlink_clk signal. For PCS option in PMA Direct mode, this clock is half the frequency of txlink_clk signal. This clock is output as an optional port for user if the txlink_clk and txframe_clk signals are operating at the same frequency in Subclass 0 operating mode.
tx_digitalreset[] <sup>(30)</sup>	L	Input	Reset for the transceiver PCS block. This reset is an active high signal. <i>Note:</i> This signal is not applicable for Intel Agilex and Intel Stratix 10 E-tile devices.
tx_digitalreset_stat[]	L	Output	TX PCS digital reset status port connected to the transceiver reset controller. This signal is applicable only for Intel Stratix 10 L-tile and H-tile devices.
tx_analogreset[] <sup>(30)</sup>	L	Input	Reset for the transceiver PMA block. This reset is an active high signal. <i>Note:</i> This signal is not applicable for Intel Agilex and Intel Stratix 10 E-tile devices.
tx_analogreset_stat[]	L	Output	TX PMA analog reset status port connected to the transceiver reset controller.
<i>continued...</i>			

<sup>(30)</sup> The Transceiver PHY Reset Controller IP core controls this signal.



Signal	Width	Direction	Description
			<i>Note:</i> This signal is applicable only for Intel Stratix 10 L-tile and H-tile devices.
pll_locked[] <sup>(30)</sup>	L	Output	This is the PLL locked output signal for the hard transceiver of the Arria V, Cyclone V, and Stratix V devices. This signal is asserted to indicate that the TX transceiver PLL is locked.
		Input	This is the input signal for the Intel Arria 10, Intel Cyclone 10 GX, and Intel Stratix 10 devices. <i>Note:</i> This signal is not applicable for Intel Agilex and Intel Stratix 10 E-tile devices.
tx_cal_busy[] <sup>(30)</sup>	L	Output	TX calibration in progress signal. This signal is asserted to indicate that the TX transceiver calibration is in progress. <i>Note:</i> This signal is not applicable for Intel Agilex and Intel Stratix 10 E-tile devices.
pll_powerdown[] <sup>(30)</sup>	<ul style="list-style-type: none"> <li>1 if bonding mode = "xN"</li> <li>L if bonding mode = feedback_compensation</li> </ul>	Input	TX transceiver PLL power down signal. This signal is only applicable for Arria V, Cyclone V, and Stratix V devices.
tx_bonding_clocks (Single Channel) tx_bonding_clocks_ch<0..L-1>[] (Multiple Channels)	6	Input	The transceiver PLL bonding clocks. The transceiver PLL generation provides these clocks. This signal is only available if you select <i>Bonded</i> mode for Intel Arria 10, Intel Cyclone 10 GX, and Intel Stratix 10 L-tile and H-tile devices. <i>Note:</i> This signal is not applicable for Intel Agilex and Intel Stratix 10 E-tile devices.
tx_serial_clk0 (Single Channel) tx_serial_clk0_ch<0..L-1> (Multiple Channels)	1	Input	The transceiver PLL serial clock. This is the serializer clock in the PMA. The transceiver PLL generation provides these clocks. This signal is only available if you select <i>Non-bonded</i> mode for Intel Arria 10, Intel Cyclone 10 GX, and Intel Stratix 10 L-tile and H-tile devices. <i>Note:</i> This signal is not applicable for Intel Agilex and Intel Stratix 10 E-tile devices.



Signal	Width	Direction	Description
<b>Transceiver Interface</b>			
tx_serial_data[]	L	Output	Differential high-speed serial output data. The clock is embedded in the serial data stream.
tx_serial_data_n	L	Output	Differential high-speed serial output data. The clock is embedded in the serial data stream. You don't need to connect this signal at the top-level pinout for proper compilation. <i>Note:</i> This signal is applicable only for Intel Agilex and Intel Stratix 10 E-tile devices.
reconfig_to_xcvr[]	<ul style="list-style-type: none"> <li>(L+1)*70 if bonding mode = "xN"</li> <li>L*140 if bonding mode = feedback compensation</li> </ul>	Input	Reconfiguration signals from the Transceiver Reconfiguration Controller IP core to the PHY device. This signal is only applicable for Arria V, Cyclone V, and Stratix V devices. You must connect these signals to the Transceiver Reconfiguration Controller IP core regardless of whether run-time reconfiguration is enabled or disabled. The Transceiver Reconfiguration Controller IP core also supports various calibration function during transceiver power up.
reconfig_from_xcvr[]	<ul style="list-style-type: none"> <li>(L+1)*46 if bonding mode = "xN"</li> <li>L*92 if bonding mode = feedback compensation</li> </ul>	Output	Reconfiguration signals to the Transceiver Reconfiguration Controller IP core. This signal is only applicable for Arria V, Cyclone V, and Stratix V devices. You must connect these signals to the Transceiver Reconfiguration Controller IP core regardless of whether run-time
<i>continued...</i>			





Signal	Width	Direction	Description
			reconfiguration is enabled or disabled. The Transceiver Reconfiguration Controller IP core also supports various calibration function during transceiver power up.
reconfig_clk reconfig_clk[] reconfig_clk_ch<0..L-1>	<ul style="list-style-type: none"> <li>1 if <b>Share Reconfiguration Interface</b> = On</li> <li>L if <b>Share Reconfiguration Interface</b> = Off and <b>Provide Separate Reconfiguration Interface for Each Channel</b> = Off</li> <li>1 bit per channel port if <b>Share Reconfiguration Interface</b> = Off and <b>Provide Separate Reconfiguration Interface for Each Channel</b> = On</li> </ul>	Input	The Avalon-MM clock input. The frequency range is 100–125 MHz. This signal is only available if you enable dynamic reconfiguration for Intel Arria 10, Intel Cyclone 10 GX, and Intel Stratix 10 devices.
reconfig_reset reconfig_reset[] reconfig_reset_ch<0..L-1>	<ul style="list-style-type: none"> <li>1 if <b>Share Reconfiguration Interface</b> = On</li> <li>L if <b>Share Reconfiguration Interface</b> = Off and <b>Provide Separate Reconfiguration Interface for Each Channel</b> = Off</li> <li>1 bit per channel port if <b>Share Reconfiguration Interface</b> = Off and <b>Provide Separate Reconfiguration Interface for Each Channel</b> = On</li> </ul>	Input	Reset signal for the Transceiver Reconfiguration Controller IP core. This signal is active high and level sensitive. This signal is only available if you enable dynamic reconfiguration for Intel Arria 10, Intel Cyclone 10 GX, and Intel Stratix 10 devices.
reconfig_avmm_address[] reconfig_avmm_address_ch<0..L-1>[]	Intel Arria 10 <ul style="list-style-type: none"> <li><math>\log_2 L * 1024</math> if <b>Share Reconfiguration Interface</b> = On</li> <li><math>10 * L</math> if <b>Share Reconfiguration Interface</b> = Off and <b>Provide Separate Reconfiguration Interface for Each Channel</b> = Off</li> <li>10 bits per channel port if <b>Share Reconfiguration Interface</b> = Off and <b>Provide Separate Reconfiguration Interface for Each Channel</b> = On</li> </ul>	Input	The Avalon-MM address. This signal is only available if you enable dynamic reconfiguration for Intel Arria 10, Intel Cyclone 10 GX, and Intel Stratix 10 devices.
<i>continued...</i>			



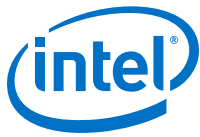
Signal	Width	Direction	Description
	Intel Stratix 10 <ul style="list-style-type: none"> <li>• <math>\log_2 L * 2048</math> if <b>Share Reconfiguration Interface</b> = On</li> <li>• <math>11 * L</math> if <b>Share Reconfiguration Interface</b> = Off and <b>Provide Separate Reconfiguration Interface for Each Channel</b> = Off</li> <li>• 11 bits per channel port if <b>Share Reconfiguration Interface</b> = Off and <b>Provide Separate Reconfiguration Interface for Each Channel</b> = On</li> </ul>		
reconfig_avmm_writedata[] reconfig_avmm_writedata_ch<0..L-1>[]	For all devices except Intel Agilex and Intel Stratix 10 E-tile. <ul style="list-style-type: none"> <li>• 32 if <b>Share Reconfiguration Interface</b> = On</li> <li>• <math>32 * L</math> if <b>Share Reconfiguration Interface</b> = Off and <b>Provide Separate Reconfiguration Interface for Each Channel</b> = Off</li> <li>• 32 bits per channel port if <b>Share Reconfiguration Interface</b> = Off and <b>Provide Separate Reconfiguration Interface for Each Channel</b> = On</li> </ul> For Intel Stratix 10 E-tile devices. <ul style="list-style-type: none"> <li>• 8 if <b>Share Reconfiguration Interface</b> = On</li> <li>• <math>8 * L</math> if <b>Share Reconfiguration Interface</b> = Off and <b>Provide Separate Reconfiguration Interface for Each Channel</b> = Off</li> <li>• 8 bits per channel port if <b>Share Reconfiguration Interface</b> = Off and <b>Provide Separate Reconfiguration Interface for Each Channel</b> = On</li> </ul>	Input	The input data. This signal is only available if you enable dynamic reconfiguration for Intel Arria 10, Intel Cyclone 10 GX, and Intel Stratix 10 devices.
reconfig_avmm_readdata[] reconfig_avmm_readdata_ch<0..L-1>[]	For all devices except Intel Agilex and Intel Stratix 10 E-tile. <ul style="list-style-type: none"> <li>• 32 if <b>Share Reconfiguration Interface</b> = On</li> <li>• <math>32 * L</math> if <b>Share Reconfiguration Interface</b> = Off and <b>Provide Separate Reconfiguration Interface for Each Channel</b> = Off</li> <li>• 32 bits per channel port if <b>Share Reconfiguration Interface</b> = Off and <b>Provide Separate Reconfiguration Interface for Each Channel</b> = On</li> </ul>	Output	The output data. This signal is only available if you enable dynamic reconfiguration for Intel Arria 10, Intel Cyclone 10 GX, and Intel Stratix 10 devices.

*continued...*



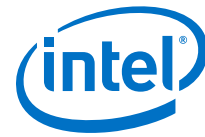
Signal	Width	Direction	Description
	<p>For Intel Agilex and Intel Stratix 10 E-tile devices.</p> <ul style="list-style-type: none"> <li>• 8 if <b>Share Reconfiguration Interface</b> = On</li> <li>• 8*L if <b>Share Reconfiguration Interface</b> = Off and <b>Provide Separate Reconfiguration Interface for Each Channel</b> = Off</li> <li>• 8 bits per channel port if <b>Share Reconfiguration Interface</b> = Off and <b>Provide Separate Reconfiguration Interface for Each Channel</b> = On</li> </ul>		
reconfig_avmm_write reconfig_avmm_write[] reconfig_avmm_write_ch<0..L-1>	<ul style="list-style-type: none"> <li>• 1 if <b>Share Reconfiguration Interface</b> = On</li> <li>• L if <b>Share Reconfiguration Interface</b> = Off and <b>Provide Separate Reconfiguration Interface for Each Channel</b> = Off</li> <li>• 1 bit per channel port if <b>Share Reconfiguration Interface</b> = Off and <b>Provide Separate Reconfiguration Interface for Each Channel</b> = On</li> </ul>	Input	Write signal. This signal is active high. This signal is only available if you enable dynamic reconfiguration for Intel Arria 10, Intel Cyclone 10 GX, and Intel Stratix 10 devices.
reconfig_avmm_read reconfig_avmm_read[] reconfig_avmm_read_ch<0..L-1>	<ul style="list-style-type: none"> <li>• 1 if <b>Share Reconfiguration Interface</b> = On</li> <li>• L if <b>Share Reconfiguration Interface</b> = Off and <b>Provide Separate Reconfiguration Interface for Each Channel</b> = Off</li> <li>• 1 bit per channel port if <b>Share Reconfiguration Interface</b> = Off and <b>Provide Separate Reconfiguration Interface for Each Channel</b> = On</li> </ul>	Input	Read signal. This signal is active high. This signal is only available if you enable dynamic reconfiguration for Intel Arria 10, Intel Cyclone 10 GX, and Intel Stratix 10 devices.
reconfig_avmm_waitrequest reconfig_avmm_waitrequest[] reconfig_avmm_waitrequest_ch<0..L-1>	<ul style="list-style-type: none"> <li>• 1 if <b>Share Reconfiguration Interface</b> = On</li> <li>• L if <b>Share Reconfiguration Interface</b> = Off and <b>Provide Separate Reconfiguration Interface for Each Channel</b> = Off</li> <li>• 1 bit per channel port if <b>Share Reconfiguration Interface</b> = Off and <b>Provide Separate Reconfiguration Interface for Each Channel</b> = On</li> </ul>	Output	Wait request signal. This signal is only available if you enable dynamic reconfiguration for Intel Arria 10, Intel Cyclone 10 GX, and Intel Stratix 10 devices.
phy_tx_ready	L	Output	Signal to indicate the transceiver TX is ready.

*continued...*



Signal	Width	Direction	Description
			<i>Note:</i> This signal is applicable only for Intel Agilex and Intel Stratix 10 E-tile devices.
phy_tx_pma_ready	L	Output	Signal to indicate the transceiver TX PMA is ready. This signal must be asserted before you assert or deassert any TX resets.  <i>Note:</i> This signal is applicable only for Intel Agilex and Intel Stratix 10 E-tile devices.
phy_tx_rst_n	1	Input	Active-high hard reset signal that resets the transceiver TX interface.  Asserting this signal does not reset the transceiver PMA. Refer to the <i>E-tile Transceiver PHY User Guide</i> about how to reset PMA through the Avalon-MM reconfiguration interface.  <i>Note:</i> This signal is applicable only for Intel Agilex and Intel Stratix 10 E-tile devices.

Signal	Width	Direction	Description
<b>Avalon-ST Interface</b>			
jesd204_tx_link_data[]	L*32	Input	Indicates a 32-bit user data at txlink_clk clock rate, where four octets are packed into a 32-bit data width per lane. The data format is big endian.  The first octet is located at bit[31:24], followed by bit[23:16], bit[15:8], and the last octet is bit[7:0]. Lane 0 data is always located in the lower 32-bit data. If more than one lane is instantiated, lane 1 is located at bit[63:32], with the first octet position at bit[63:56].
<i>continued...</i>			



Signal	Width	Direction	Description
jesd204_tx_link_valid	1	Input	Indicates whether the data from the transport layer is valid or invalid. The Avalon-ST sink interface in the TX core cannot be backpressured and assumes that data is always valid on every cycle when the <code>jesd204_tx_link_ready</code> signal is asserted. <ul style="list-style-type: none"> <li>0—data is invalid</li> <li>1—data is valid</li> </ul>
jesd204_tx_link_ready	1	Output	Indicates that the Avalon-ST sink interface in the TX core is ready to accept data. The Avalon-ST sink interface asserts this signal on the JESD204B link state of <code>USER_DATA</code> phase. The ready latency is 0.
jesd204_tx_frame_ready	1	Output	Indicates that the Avalon-ST sink interface in the transport layer is ready to accept data. The Avalon-ST sink interface asserts this signal on the JESD204B link state of ILAS 4 <sup>th</sup> multiframe and also the <code>USER_DATA</code> phase. The ready latency is 0.

Signal	Width	Direction	Description
<b>Avalon-MM Interface</b>			
jesd204_tx_avs_clk	1	Input	The Avalon-MM interface clock signal. This clock is asynchronous to all the functional clocks in the JESD204B IP core. The JESD204B IP core can handle any cross clock ratio and therefore the clock frequency can range from 75 MHz to 125 MHz.
jesd204_tx_avs_rst_n	1	Input	This reset is associated with the <code>jesd204_tx_avs_clk</code> signal. This reset is an active low signal. You can assert this reset signal asynchronously but must deassert it synchronously to the <code>jesd204_tx_avs_clk</code> signal. After you deassert this signal, the CPU can configure the CSRs.
jesd204_tx_avs_chipselect	1	Input	When this signal is present, the slave port ignores all Avalon-MM signals unless this signal is asserted. This signal must be used in combination with read or write. If the Avalon-MM bus does not support chip select, you are recommended to tie this port to 1.
jesd204_tx_avs_address[]	8	Input	For Avalon-MM slave, the interconnect translates the byte address into a word address in the address space so that each slave access is for a word of data. For example, <code>address = 0</code> selects the first word of the slave and <code>address = 1</code> selects the second word of the slave.
jesd204_tx_avs_writedata[]	32	Input	32-bit data for write transfers. The width of this signal and the <code>jesd204_tx_avs_readdata[31:0]</code> signal must be the same if both signals are present
jesd204_tx_avs_read	1	Input	This signal is asserted to indicate a read transfer. This is an active high signal and requires the <code>jesd204_tx_avs_readdata[31:0]</code> signal to be in use.
<i>continued...</i>			



Signal	Width	Direction	Description
jesd204_tx_avs_write	1	Input	This signal is asserted to indicate a write transfer. This is an active high signal and requires the jesd204_tx_avs_writedata[31:0] signal to be in use.
jesd204_tx_avs_readdata[]	32	Output	32-bit data driven from the Avalon-MM slave to master in response to a read transfer.
jesd204_tx_avs_waitrequest	1	Output	This signal is asserted by the Avalon-MM slave to indicate that it is unable to respond to a read or write request. The JESD204B IP core ties this signal to 0 to return the data in the access cycle.

Signal	Width	Direction	Description
<b>JESD204 Interface</b>			
sysref	1	Input	<i>SYSREF</i> signal for JESD204B Subclass 1 implementation. For Subclass 0 and Subclass 2 mode, tie-off this signal to 0.
sync_n	1	Input	Indicates <i>SYNC_N</i> from the converter device or receiver. This is an active low signal and is asserted 0 to indicate a synchronization request or error reporting from the converter device.  To indicate a synchronization request, the converter device must assert this signal for at least five frames and nine octets.  To indicate an error reporting, the converter device must ensure that the pulse is at least one cycle of the <i>txlink_clk</i> signal or two cycles of the <i>txframe_clk</i> signal (whichever period is longer).
dev_sync_n	1	Output	Indicates a clean synchronization request. This is an active low signal and is asserted 0 to indicate a synchronization request only. The <i>sync_n</i> signal error reporting is being masked out of this signal. This signal is also asserted during software-initiated synchronization.
mdev_sync_n	1	Input	Indicates a multidevice synchronization request. Synchronize signal combination should be done externally and then input to the JESD204B IP core through this signal. <ul style="list-style-type: none"> <li>For subclass 0—combine the <i>dev_sync_n</i> signal from all multipoint links before connecting to the <i>mdev_sync_n</i> signal.</li> <li>For subclass 1—connect the <i>dev_sync_n</i> signal to the <i>mdev_sync_n</i> signal for each link respectively.</li> </ul> In a single link instance where multidevice synchronization is not needed, tie the <i>dev_sync_n</i> signal to this signal.
somf[]	4	Output	Indicates a start of multiframe. <ul style="list-style-type: none"> <li>[3]—start of multiframe for jesd204_tx_link_data[31:24]</li> <li>[2]—start of multiframe for jesd204_tx_link_data[23:16]</li> <li>[1]—start of multiframe for jesd204_tx_link_data[15:8]</li> <li>[0]—start of multiframe for jesd204_tx_link_data[7:0]</li> </ul>



Signal	Width	Direction	Description
<b>CSR</b>			
jesd204_tx_frame_error	1	Input	Optional signal to indicate an empty data stream due to invalid data. This signal is asserted high to indicate an error during data transfer from the transport layer to the TX core.
csr_l[]	5	Output	Indicates the number of active lanes for the link. The transport layer can use this signal as a run-time parameter.
csr_f[]	8	Output	Indicates the number of octets per frame. The transport layer can use this signal as a run-time parameter.
csr_k[]	5	Output	Indicates the number of frames per multiframe. The transport layer can use this signal as a run-time parameter.
csr_m[]	8	Output	Indicates the number of converters for the link. The transport layer can use this signal as a run-time parameter.
csr_cs[]	2	Output	Indicates the number of control bits per sample. The transport layer can use this signal as a run-time parameter.
csr_n[]	5	Output	Indicates the converter resolution. The transport layer can use this signal as a run-time parameter.
csr_np[]	5	Output	Indicates the total number of bits per sample. The transport layer can use this signal as a run-time parameter.
csr_s[]	5	Output	Indicates the number of samples per converter per frame cycle. The transport layer can use this signal as a run-time parameter.
csr_hd	1	Output	Indicates the high density data format. The transport layer can use this signal as a run-time parameter.
csr_cf[]	5	Output	Indicates the number of control words per frame clock period per link. The transport layer can use this signal as a run-time parameter.
csr_lane_powerdown[]	L	Output	Indicates which lane is powered down. You need to set this signal if you have configured the link and want to reduce the number of active lanes.

Signal	Width	Direction	Description
<b>Out-of-band (OOB)</b>			
jesd204_tx_int	1	Output	Interrupt pin for the JESD204B IP core. Interrupt is asserted when any error or synchronization request is detected. Configure the tx_err_enable register to set the type of error that can trigger an interrupt.

Signal	Width	Direction	Description
<b>Debug or Testing</b>			
jesd204_tx_dlb_data[]	L*32	Output	Optional signal for parallel data from the DLL in TX to RX loopback testing. <sup>(31)</sup>
<i>continued...</i>			



Signal	Width	Direction	Description
jesd204_tx_dlb_kchar_data[ ]	L*4	Output	Optional signal to indicate the K character value for each byte in TX to RX loopback testing. <sup>(31)</sup>
csr_tx_testmode[ ]	4	Output	Indicates the test mode for the JESD204B IP core and the test pattern for the test pattern generator in the design example. <i>Note:</i> The test pattern generator is a component of the design example and is not a part of the JESD204B IP core. Refer to the <code>tx_test</code> register in the register map.
csr_tx_testpattern_a[ ]	32	Output	A 32-bit fixed data pattern for testing purpose, such as short transport layer test pattern. You can configure the fixed data pattern through the TX register <code>user_test_pattern_a</code> (offset 0xD4) <sup>(32)</sup>
csr_tx_testpattern_b[ ]	32	Output	A 32-bit fixed data pattern for testing purpose, such as short transport layer test pattern. You can configure the fixed data pattern through the TX register <code>user_test_pattern_b</code> (offset 0xD8) <sup>(32)</sup>
csr_tx_testpattern_c[ ]	32	Output	A 32-bit fixed data pattern for testing purpose, such as short transport layer test pattern. You can configure the fixed data pattern through the TX register <code>user_test_pattern_c</code> (offset 0xDC) <sup>(32)</sup>
csr_tx_testpattern_d[ ]	32	Output	A 32-bit fixed data pattern for testing purpose, such as short transport layer test pattern. You can configure the fixed data pattern through the TX register <code>user_test_pattern_d</code> (offset 0xE0) <sup>(32)</sup>

<sup>(31)</sup> This signal is only for internal testing purposes. You can leave this signal disconnected.

<sup>(32)</sup> You can connect this signal to the TX transport layer as test data samples or to the JESD204B TX IP core to emulate data from the TX transport layer. You may ignore this signal if unused. to the JESD204B TX IP core.

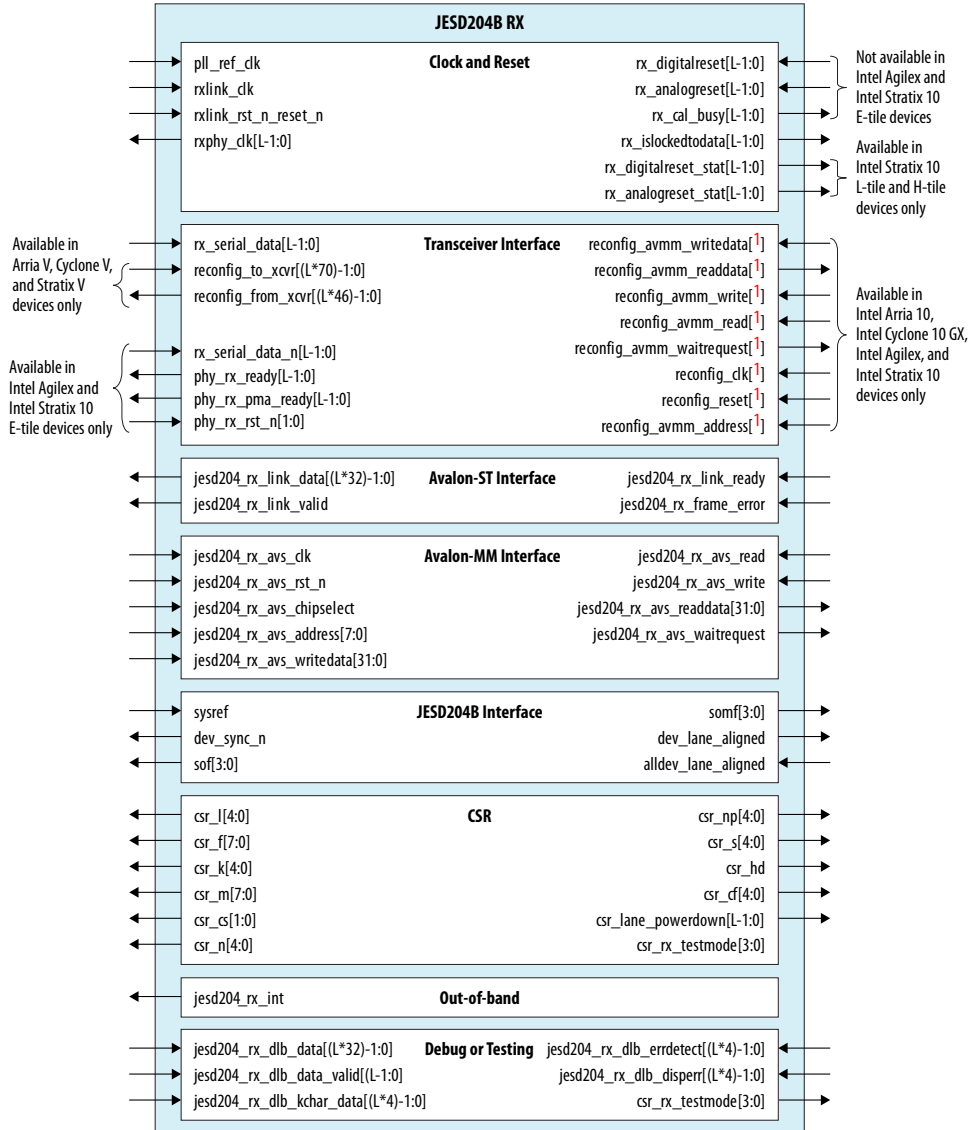




## 4.6.2. Receiver Signals

Figure 24. Receiver Signal Diagram

L denotes the number of lanes.



Note:  
 1. Refer to the Receiver Signals table for actual signal width and name.

Table 26. Receiver Signals

Signal	Width	Direction	Description
<b>Clocks and Resets</b>			
<code>pll_ref_clk</code>	1	Input	Transceiver reference clock signal.
<code>rxlink_clk</code>	1	Input	RX link clock signal used by the Avalon-ST interface. This clock is equal to RX data rate divided by 40.
<i>continued...</i>			



Signal	Width	Direction	Description
			For Subclass 1, you cannot use the output of rxphy_clk signal as rxlink_clk signal. To sample SYSREF correctly, the core PLL must provide the rxlink_clk signal and must be configured as normal operating mode.
rxlink_rst_n_reset_n	1	Input	Reset for the RX link clock signal. This reset is an active low signal.
rxphy_clk[]	L	Output	Recovered clock signal. This clock is derived from the clock data recovery (CDR) and the frequency depends on the JESD204B IP core data rate. <ul style="list-style-type: none"> <li>For PCS option in Hard PCS or Soft PCS mode, this clock has the same frequency as the rxlink_clk signal.</li> <li>For PCS option in PMA Direct mode, this clock is half the frequency of rxlink_clk signal.</li> </ul>
rx_digitalreset[] <sup>(33)</sup>	L	Input	Reset for the transceiver PCS block. This reset is an active high signal. <i>Note:</i> This signal is not applicable for Intel Agilex and Intel Stratix 10 E-tile devices.
rx_digitalreset_stat[]	L	Output	TX PCS digital reset status port connected to the transceiver reset controller. <i>Note:</i> This signal is applicable only for Intel Stratix 10 L-tile and H-tile devices.
rx_analogreset[] <sup>(33)</sup>	L	Input	Reset for the CDR and transceiver PMA block. This reset is an active high signal. <i>Note:</i> This signal is not applicable for Intel Agilex and Intel Stratix 10 E-tile devices.
rx_analogreset_stat[]	L	Output	TX PMA analog reset status port connected to the transceiver reset controller. <i>Note:</i> This signal is applicable only for Intel Stratix 10 L-tile and H-tile devices.
rx_islockedtoata[] <sup>(33)</sup>	L	Output	This signal is asserted to indicate that the RX CDR PLL is locked to the RX data and the RX CDR has changed from LTR to LTD mode.
rx_cal_busy[] <sup>(33)</sup>	L	Output	RX calibration in progress signal. This signal is asserted to indicate that the RX transceiver calibration is in progress. <i>Note:</i> This signal is not applicable for Intel Agilex and Intel Stratix 10 E-tile devices.

Signal	Width	Direction	Description
<b>Transceiver Interface</b>			
rx_serial_data[]	L	Input	Differential high-speed serial input data. The clock is recovered from the serial data stream.
<i>continued...</i>			

<sup>(33)</sup> The Transceiver PHY Reset Controller IP Core controls this signal.



Signal	Width	Direction	Description
rx_serial_data_n	L	Input	Differential high-speed serial input data. The clock is recovered from the serial data stream.  <i>Note:</i> This signal is applicable only for Intel Agilex and Intel Stratix 10 E-tile devices.
reconfig_to_xcvr[]	L*70	Input	Dynamic reconfiguration input for the hard transceiver. This signal is only applicable for for Arria V, Cyclone V, and Stratix V devices. You must connect these signals to the Transceiver Reconfiguration Controller IP core regardless of whether run-time reconfiguration is enabled or disabled. The Transceiver Reconfiguration Controller IP core also supports various calibration function during transceiver power up.
reconfig_from_xcvr[]	L*46	Output	Dynamic reconfiguration output for the hard transceiver. This signal is only applicable for for Arria V, Cyclone V, and Stratix V devices You must connect these signals to the Transceiver Reconfiguration Controller IP core regardless of whether run-time reconfiguration is enabled or disabled. The Transceiver Reconfiguration Controller IP core also supports various calibration function during transceiver power up.
<i>continued...</i>			



Signal	Width	Direction	Description
reconfig_clk reconfig_clk[] reconfig_clk_ch<0..L-1>	<ul style="list-style-type: none"> <li>• 1 if <b>Share Reconfiguration Interface</b> = On</li> <li>• L if <b>Share Reconfiguration Interface</b> = Off and <b>Provide Separate Reconfiguration Interface for Each Channel</b> = Off</li> <li>• 1 bit per channel port if <b>Share Reconfiguration Interface</b> = Off and <b>Provide Separate Reconfiguration Interface for Each Channel</b> = On</li> </ul>	Input	<p>The Avalon-MM clock input. The frequency range is 100–125 MHz.</p> <p>This signal is only available if you enable dynamic reconfiguration for Intel Arria 10, Intel Cyclone 10 GX, and Intel Stratix 10 devices.</p>
reconfig_reset reconfig_reset[] reconfig_reset_ch<0..L-1>	<ul style="list-style-type: none"> <li>• 1 if <b>Share Reconfiguration Interface</b> = On</li> <li>• L if <b>Share Reconfiguration Interface</b> = Off and <b>Provide Separate Reconfiguration Interface for Each Channel</b> = Off</li> <li>• 1 bit per channel port if <b>Share Reconfiguration Interface</b> = Off and <b>Provide Separate Reconfiguration Interface for Each Channel</b> = On</li> </ul>	Input	<p>Reset signal for the Transceiver Reconfiguration Controller IP core. This signal is active high and level sensitive.</p> <p>This signal is only available if you enable dynamic reconfiguration for Intel Arria 10, Intel Cyclone 10 GX, and Intel Stratix 10 devices.</p>
reconfig_avmm_address[] reconfig_avmm_address_ch<0..L-1>[]	<p>Intel Arria 10 and Intel Cyclone 10 GX</p> <ul style="list-style-type: none"> <li>• <math>\log_2 L * 1024</math> if <b>Share Reconfiguration Interface</b> = On</li> <li>• <math>10 * L</math> if <b>Share Reconfiguration Interface</b> = Off and <b>Provide Separate Reconfiguration Interface for Each Channel</b> = Off</li> <li>• 10 bits per channel port if <b>Share Reconfiguration Interface</b> = Off and <b>Provide Separate Reconfiguration Interface for Each Channel</b> = On</li> </ul> <p>Intel Stratix 10</p> <ul style="list-style-type: none"> <li>• <math>\log_2 L * 2048</math> if <b>Share Reconfiguration Interface</b> = On</li> <li>• <math>11 * L</math> if <b>Share Reconfiguration Interface</b> = Off and <b>Provide Separate Reconfiguration Interface for Each Channel</b> = Off</li> <li>• 11 bits per channel port if <b>Share Reconfiguration Interface</b> = Off and <b>Provide Separate Reconfiguration Interface for Each Channel</b> = On</li> </ul>	Input	<p>The Avalon-MM address.</p> <p>This signal is only available if you enable dynamic reconfiguration for Intel Arria 10, Intel Cyclone 10 GX, and Intel Stratix 10 devices.</p>

*continued...*



Signal	Width	Direction	Description
reconfig_avmm_writedata[] reconfig_avmm_writedata_ch<0..L-1>[]	<p>For all devices except Intel Agilex and Intel Stratix 10 E-tile.</p> <ul style="list-style-type: none"> <li>• 32 if <b>Share Reconfiguration Interface</b> = On</li> <li>• 32*L if <b>Share Reconfiguration Interface</b> = Off and <b>Provide Separate Reconfiguration Interface for Each Channel</b> = Off</li> <li>• 32 bits per channel port if <b>Share Reconfiguration Interface</b> = Off and <b>Provide Separate Reconfiguration Interface for Each Channel</b> = On</li> </ul> <p>For Intel Agilex and Intel Stratix 10 E-tile devices.</p> <ul style="list-style-type: none"> <li>• 8 if <b>Share Reconfiguration Interface</b> = On</li> <li>• 8*L if <b>Share Reconfiguration Interface</b> = Off and <b>Provide Separate Reconfiguration Interface for Each Channel</b> = Off</li> <li>• 8 bits per channel port if <b>Share Reconfiguration Interface</b> = Off and <b>Provide Separate Reconfiguration Interface for Each Channel</b> = On</li> </ul>	Input	The input data. This signal is only available if you enable dynamic reconfiguration for Intel Arria 10, Intel Cyclone 10 GX, and Intel Stratix 10 devices.
reconfig_avmm_readdata[] reconfig_avmm_readdata_ch<0..L-1>[]	<p>For all devices except Intel Agilex and Intel Stratix 10 E-tile.</p> <ul style="list-style-type: none"> <li>• 32 if <b>Share Reconfiguration Interface</b> = On</li> <li>• 32*L if <b>Share Reconfiguration Interface</b> = Off and <b>Provide Separate Reconfiguration Interface for Each Channel</b> = Off</li> <li>• 32 bits per channel port if <b>Share Reconfiguration Interface</b> = Off and <b>Provide Separate Reconfiguration Interface for Each Channel</b> = On</li> </ul> <p>For Intel Agilex and Intel Stratix 10 E-tile devices.</p> <ul style="list-style-type: none"> <li>• 8 if <b>Share Reconfiguration Interface</b> = On</li> <li>• 8*L if <b>Share Reconfiguration Interface</b> = Off and <b>Provide Separate Reconfiguration Interface for Each Channel</b> = Off</li> <li>• 8 bits per channel port if <b>Share Reconfiguration Interface</b> = Off and <b>Provide Separate Reconfiguration Interface for Each Channel</b> = On</li> </ul>	Output	The output data. This signal is only available if you enable dynamic reconfiguration for Intel Arria 10, Intel Cyclone 10 GX, and Intel Stratix 10 devices.

*continued...*



Signal	Width	Direction	Description
reconfig_avmm_write reconfig_avmm_write[] reconfig_avmm_write_ch<0..L-1>	<ul style="list-style-type: none"> <li>• 1 if <b>Share Reconfiguration Interface</b> = On</li> <li>• L if <b>Share Reconfiguration Interface</b> = Off and <b>Provide Separate Reconfiguration Interface for Each Channel</b> = Off</li> <li>• 1 bit per channel port if <b>Share Reconfiguration Interface</b> = Off and <b>Provide Separate Reconfiguration Interface for Each Channel</b> = On</li> </ul>	Input	Write signal. This signal is active high. This signal is only available if you enable dynamic reconfiguration for Intel Arria 10, Intel Cyclone 10 GX, and Intel Stratix 10 devices.
reconfig_avmm_read reconfig_avmm_read[] reconfig_avmm_read_ch<0..L-1>	<ul style="list-style-type: none"> <li>• 1 if <b>Share Reconfiguration Interface</b> = On</li> <li>• L if <b>Share Reconfiguration Interface</b> = Off and <b>Provide Separate Reconfiguration Interface for Each Channel</b> = Off</li> <li>• 1 bit per channel port if <b>Share Reconfiguration Interface</b> = Off and <b>Provide Separate Reconfiguration Interface for Each Channel</b> = On</li> </ul>	Input	Read signal. This signal is active high. This signal is only available if you enable dynamic reconfiguration for Intel Arria 10, Intel Cyclone 10 GX, and Intel Stratix 10 devices.
reconfig_avmm_waitrequest reconfig_avmm_waitrequest[] reconfig_avmm_waitrequest_ch<0..L-1>	<ul style="list-style-type: none"> <li>• 1 if <b>Share Reconfiguration Interface</b> = On</li> <li>• L if <b>Share Reconfiguration Interface</b> = Off and <b>Provide Separate Reconfiguration Interface for Each Channel</b> = Off</li> <li>• 1 bit per channel port if <b>Share Reconfiguration Interface</b> = Off and <b>Provide Separate Reconfiguration Interface for Each Channel</b> = On</li> </ul>	Output	Wait request signal. This signal is only available if you enable dynamic reconfiguration for Intel Arria 10, Intel Cyclone 10 GX, and Intel Stratix 10 devices.
phy_rx_ready	L	Output	Signal to indicate the transceiver RX is ready. <i>Note:</i> This signal is applicable only for Intel Agilex and Intel Stratix 10 E-tile devices.
phy_rx_pma_ready	L	Output	Signal to indicate the transceiver RX PMA is ready. This signal must be asserted before you assert or deassert any RX resets. <i>Note:</i> This signal is applicable only for Intel Agilex and Intel Stratix 10 E-tile devices.
phy_rx_rst_n	1	Input	Active-high hard reset signal that resets the transceiver RX interface.



Signal	Width	Direction	Description
			Asserting this signal does not reset the transceiver PMA. Refer to the <i>E-tile Transceiver PHY User Guide</i> about how to reset PMA through the Avalon-MM reconfiguration interface.  <i>Note:</i> This signal is applicable only for Intel Agilex and Intel Stratix 10 E-tile devices.

Signal	Width	Direction	Description
<b>Avalon-ST Interface</b>			
jesd204_rx_link_data[]	L*32	Output	Indicates a 32-bit data from the DLL to the transport layer. The data format is big endian, where the earliest octet is placed in bit [31:24] and the latest octet is placed in bit [7:0].
jesd204_rx_link_valid	1	Output	Indicates whether the data to the transport layer is valid or invalid. The Avalon-ST source interface in the RX core cannot be backpressured and transmits the data when the <code>jesd204_rx_data_valid</code> signal is asserted. <ul style="list-style-type: none"> <li>0—data is invalid</li> <li>1—data is valid</li> </ul>
jesd204_rx_link_ready	1	Input	Indicates that the Avalon-ST sink interface in the transport layer is ready to receive data.
jesd204_rx_frame_error	1	Input	Indicates an empty data stream due to invalid data. This signal is asserted high to indicate an error during data transfer from the RX core to the transport layer.

Signal	Width	Direction	Description
<b>Avalon-MM Interface</b>			
jesd204_rx_avs_clk	1	Input	The Avalon-MM interface clock signal. This clock is asynchronous to all the functional clocks in the JESD204B IP core. The JESD204B IP core can handle any cross clock ratio and therefore the clock frequency can range from 75 MHz to 125 MHz.
jesd204_rx_avs_rst_n	1	Input	This reset is associated with the <code>jesd204_rx_avs_clk</code> signal. This reset is an active low signal. You can assert this reset signal asynchronously but must deassert it synchronously to the <code>jesd204_rx_avs_clk</code> signal. After you deassert this signal, the CPU can configure the CSRs.
jesd204_rx_avs_chipselect	1	Input	When this signal is present, the slave port ignores all Avalon-MM signals unless this signal is asserted. This signal must be used in combination with read or write. If the Avalon-MM bus does not support chip select, you are recommended to tie this port to 1.
<i>continued...</i>			



Signal	Width	Direction	Description
jesd204_rx_avs_address[]	8	Input	For Avalon-MM slave, the interconnect translates the byte address into a word address in the address space so that each slave access is for a word of data. For example, address = 0 selects the first word of the slave and address = 1 selects the second word of the slave.
jesd204_rx_avs_writedata[]	32	Input	32-bit data for write transfers. The width of this signal and the jesd204_rx_avs_readdata[31:0] signal must be the same if both signals are present.
jesd204_rx_avs_read	1	Input	This signal is asserted to indicate a read transfer. This is an active high signal and requires the jesd204_rx_avs_readdata[31:0] signal to be in use.
jesd204_rx_avs_write	1	Input	This signal is asserted to indicate a write transfer. This is an active high signal and requires the jesd204_rx_avs_writedata[31:0] signal to be in use.
jesd204_rx_avs_readdata[]	32	Output	32-bit data driven from the Avalon-MM slave to master in response to a read transfer.
jesd204_rx_avs_waitrequest	1	Output	This signal is asserted by the Avalon-MM slave to indicate that it is unable to respond to a read or write request. The JESD204B IP core ties this signal to 0 to return the data in the access cycle.

Signal	Width	Direction	Description
<b>JESD204 Interface</b>			
sysref	1	Input	SYSREF signal for JESD204B Subclass 1 implementation. For Subclass 0 and Subclass 2 mode, tie-off this signal to 0.
dev_sync_n	1	Output	Indicates a SYNC~ from the receiver. This is an active low signal and is asserted 0 to indicate a synchronization request. Instead of reporting the link error through this signal, the JESD204B IP core uses the jesd204_rx_int signal to interrupt the CPU. For multilink synchronization, you can optionally connect the DEV_SYNC_N from each IP core to the input of an AND gate. The output of the AND gate is exported to the FPGA pins for connection to the analog-to-digital converters. Refer to AN803 and AN804 for more information about the connection guidelines.
sof[]	4	Output	Indicates a start of frame. <ul style="list-style-type: none"> <li>[3]—start of frame for jesd204_rx_link_data[31:24]</li> <li>[2]—start of frame for jesd204_rx_link_data[23:16]</li> <li>[1]—start of frame for jesd204_rx_link_data[15:8]</li> <li>[0]—start of frame for jesd204_rx_link_data[7:0]</li> </ul>
<i>continued...</i>			





Signal	Width	Direction	Description
somf[]	4	Output	Indicates a start of multiframe. <ul style="list-style-type: none"> <li>[3]—start of multiframe for jesd204_rx_link_data[31:24]</li> <li>[2]—start of multiframe for jesd204_rx_link_data[23:16]</li> <li>[1]—start of multiframe for jesd204_rx_link_data[15:8]</li> <li>[0]—start of multiframe for jesd204_rx_link_data[7:0]</li> </ul>
dev_lane_aligned	1	Output	Indicates that all lanes for this device are aligned.
alldev_lane_aligned	1	Input	Aligns all lanes for this device. For multidevice synchronization, input all the dev_lane_aligned signals to an AND gate and connect the AND gate output to this pin. For single device support, connect the dev_lane_aligned signal back to this signal.

Signal	Width	Direction	Description
<b>CSR</b>			
csr_l[]	5	Output	Indicates the number of active lanes for the link. The transport layer can use this signal as a run-time parameter.
csr_f[]	8	Output	Indicates the number of octets per frame. The transport layer can use this signal as a run-time parameter.
csr_k[]	5	Output	Indicates the number of frames per multiframe. The transport layer can use this signal as a run-time parameter.
csr_m[]	8	Output	Indicates the number of converters for the link. The transport layer can use this signal as a run-time parameter.
csr_cs[]	2	Output	Indicates the number of control bits per sample. The transport layer can use this signal as a run-time parameter.
csr_n[]	5	Output	Indicates the converter resolution. The transport layer can use this signal as a run-time parameter.
csr_np[]	5	Output	Indicates the total number of bits per sample. The transport layer can use this signal as a run-time parameter.
csr_s[]	5	Output	Indicates the number of samples per converter per frame cycle. The transport layer can use this signal as a run-time parameter.
csr_hd	1	Output	Indicates the high density data format. The transport layer can use this signal as a run-time parameter.
csr_cf[]	5	Output	Indicates the number of control words per frame clock period per link. The transport layer can use this signal as a run-time parameter.
csr_lane_powerdown[]	L	Output	Indicates which lane is powered down. You need to set this signal if you have configured the link and want to reduce the number of active lanes.



Signal	Width	Direction	Description
<b>Out-of-band (OOB)</b>			
jesd204_rx_int	1	Output	Interrupt pin for the JESD204B IP core. Interrupt is asserted when any error is detected. Configure the <code>rx_err_enable</code> register to set the type of error that can trigger an interrupt.

Signal	Width	Direction	Description
<b>Debug or Testing</b>			
jesd204_rx_dlb_data[]	L*32	Input	Optional signal for parallel data to the DLL in TX to RX loopback testing. <sup>(34)</sup>
csr_rx_testmode[]	4	Output	Indicates the test mode for the JESD204B IP core and the test pattern for the test pattern checker in the design example. <i>Note:</i> The test pattern checker is a component of the design example and is not a part of the JESD204B IP core. Refer to the <code>rx_test</code> register in the register map.
jesd204_rx_dlb_data_valid[]	L	Input	Optional signal to indicate valid data for each byte in TX to RX loopback testing. <sup>(34)</sup>
jesd204_rx_dlb_kchar_data[]	L*4	Input	Optional signal to indicate the K character value for each byte in TX to RX loopback testing. <sup>(34)</sup>
jesd204_rx_dlb_errdetect[]	L*4	Input	Optional signal to indicate 8B/10B error. <sup>(34)</sup>
jesd204_rx_dlb_disperr[]	L*4	Input	Optional signal to indicate running disparity. <sup>(34)</sup>

#### Related Information

- [AN803: Implementing ADC-Intel Arria 10 Multi-Link Design with JESD204B RX IP Core](#)
- [AN804: Implementing ADC-Intel Stratix 10 Multi-Link Design with JESD204B RX IP Core](#)

## 4.7. Registers

The JESD204B IP core supports a basic one clock cycle transaction bus. There is no support for burst mode and wait-state feature (the `avs_waitrequest` signal is tied to 0). The JESD204B IP core Avalon-MM slave interface has a data width of 32 bits and is implemented based on word addressing. The Avalon-MM slave interface does not support byte enable access.

Each write transfer has a *writeWaitTime* of 0 cycle while a read transfer has a *readWaitTime* of 1 cycle and *readLatency* of 1 cycle.

The following sections list the TX and RX core registers. The register address in the register map is written based on byte addressing. The Platform Designer interconnect automatically converts from byte to word addressing. You do not need to manually shift the address bus. If the Avalon-MM master interfaces to the IP core Avalon-MM slave without the Platform Designer interconnect, to perform byte to word addressing conversion, you are recommended to shift the Avalon-MM master address bus by 2

---

<sup>(34)</sup> This signal is only for internal testing purposes. Tie this signal to low.



bits (divide by 4) when connecting to the IP core's Avalon-MM slave. In this connection, the Avalon-MM master address bit[2] connects to the IP core (Avalon-MM slave) address bit[0], while the Avalon-MM master bit[9] connects to the IP core address bit[7].

**Note:** For Intel Stratix 10 devices, run-time access for certain registers have been disabled. Refer to the TX and RX register map for more information.

### 4.7.1. Register Access Type Convention

This table describes the register access type for Intel FPGA IP cores.

**Table 27. Register Access Type and Definition**

Access Type	Definition
RO	Software read only (no effect on write). The value is hard-tied internally to either '0' or '1' and does not vary.
RO/v	Software read only (no effect on write). The value may vary.
RC	<ul style="list-style-type: none"> <li>Software reads and returns the current bit value, then the bit is self-clear to 0.</li> <li>Software reads also cause the bit value to be cleared to 0.</li> </ul>
RW	<ul style="list-style-type: none"> <li>Software reads and returns the current bit value.</li> <li>Software writes and sets the bit to the desired value.</li> </ul>
RW1C	<ul style="list-style-type: none"> <li>Software reads and returns the current bit value.</li> <li>Software writes 0 and have no effect.</li> <li>Software writes 1 and clear the bit to 0, if the bit has been set to 1 by hardware.</li> <li>Hardware sets the bit to 1.</li> <li>Software clear has higher priority than hardware set.</li> </ul>
RW1S	<ul style="list-style-type: none"> <li>Software reads and returns the current bit value.</li> <li>Software writes 0 and have no effect.</li> <li>Software writes 1 and set the bit to 1.</li> <li>Hardware clears the bit to 0, if the bit has been set to 1 by software.</li> <li>Software set has higher priority than hardware clear.</li> </ul>

### 4.7.2. Transmitter Registers

**Table 28. lane\_ctrl\_common**

Common lane control and assignment. The common lane control applies to all lanes in the link..

Offset: 0x0

**Note:** The bits that are compile-time specific are not configurable through register. You must recompile to change the value.)

Bit	Name	Description	Attribute	Reset
31:3	Reserved	Reserved	R	0x0
2	rl	Physical lane control reserve register	RW	0x0
1	csr_bit reversal	Bit reversal for LSB/MSB first serialization. This is a compile-time option which needs to be set before IP generation.	R	Compile-time specific

*continued...*



Bit	Name	Description	Attribute	Reset
		<ul style="list-style-type: none"> <li>0 = LSB-first serialization</li> <li>1 = MSB-first serialization</li> </ul> <p>Note: JESD204B converter device may support either MSB-first serialization or LSB-first serialization.</p> <p>You must set both <code>csr_byte_reversal</code> and <code>csr_bit_reversal</code> bits to 1 when generating the IP.</p> <p>When <code>csr_bit_reversal</code> = 1, the word aligner reverses the TX parallel data bits before transmitting it to the PMA for serialization.</p> <p>For example; in 20-bit mode; D[19:0] is rewired to D[0:19] and in 40-bit mode; D[39:0] is rewired to D[0:39].</p>		
0	<code>csr_byte_reversal</code>	<p>Byte reversal for LSB/MSB first serialization. This is a compile-time option which needs to be set before IP generation.</p> <ul style="list-style-type: none"> <li>0 = LSB-first serialization Byte order = {octet3, octet2, octet1, octet0}</li> <li>1 = MSB-first serialization Byte order = {octet0, octet1, octet2, octet3}</li> </ul> <p>Note: JESD204B converter device may support either MSB-first serialization or LSB-first serialization.</p> <p>When <code>csr_byte_reversal</code> = 1, the byte order is reversed before transmitting data.</p>	R	Compile-time specific

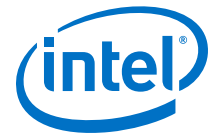
**Table 29. lane\_ctrl\_0**

Lane control and assignment for Lane 0.

Offset: 0x4

Bit	Name	Description	Attribute	Reset
31:10	Reserved	Reserved	R	0x0
9:2	<code>r10</code>	Physical lane control reserve register	RW	0x0
1	<code>csr_lane0_powerdown</code>	<p>Power down control for lane 0. This register routes out of the IP as <code>csr_lane_powerdown[0]</code>. The transport layer (TL) uses this signal to indicate the fall back of the lanes (L) for run-time LMF support.</p> <p>To save power, route this signal to the Transceiver Reset Controller block as an assert mask for <code>rx_digitalreset</code> and <code>rx_analogreset</code> to power down the lane.</p> <ul style="list-style-type: none"> <li>0 = Normal mode</li> <li>1 = Power down</li> </ul>	RW	0x0

*continued...*



Bit	Name	Description	Attribute	Reset
		<i>Note:</i> This status bit is not applicable for Intel Agilex and Intel Stratix 10 E-tile devices.		
0	csr_lane0_polarity	Set 1 to inverse lane 0 polarity. When set, the TX interface inverts the polarity of the TX data. You can use this bit to correct the polarity of differential pairs if the transmission circuitry or board layout mistakenly swaps the positive and negative signals.	RW	0x0

**Table 30. lane\_ctrl\_1**

Lane control and assignment for Lane 1.

Offset: 0x8

Bit	Name	Description	Attribute	Reset
31:10	Reserved	Reserved	R	0x0
9:2	r1	Physical lane control reserve register	RW	0x0
1	csr_lane1_powerdown	Power down control for lane 1. This register routes out of the IP as <code>csr_lane_powerdown[1]</code> . The transport layer (TL) uses this signal to indicate the fall back of the lanes (L) for run-time LMF support. To save power, route this signal to the Transceiver Reset Controller block as an assert mask for <code>rx_digitalreset</code> and <code>rx_analogreset</code> to power down the lane. <ul style="list-style-type: none"> <li>0 = Normal mode</li> <li>1 = Power down</li> </ul> <i>Note:</i> This status bit is not applicable for Intel Agilex and Intel Stratix 10 E-tile devices.	RW	0x0
0	csr_lane1_polarity	Set 1 to inverse lane 1 polarity. When set, the TX interface inverts the polarity of the TX data. You can use this bit to correct the polarity of differential pairs if the transmission circuitry or board layout mistakenly swaps the positive and negative signals.	RW	0x0

**Table 31. lane\_ctrl\_2**

Lane control and assignment for Lane 2.

Offset: 0xC

Bit	Name	Description	Attribute	Reset
31:10	Reserved	Reserved	R	0x0
9:2	r2	Physical lane control reserve register	RW	0x0
1	csr_lane2_powerdown	Power down control for lane 2.	RW	0x0

*continued...*



Bit	Name	Description	Attribute	Reset
		<p>This register routes out of the IP as <code>csr_lane_powerdown[2]</code>. The transport layer (TL) uses this signal to indicate the fall back of the lanes (L) for run-time LMF support.</p> <p>To save power, route this signal to the Transceiver Reset Controller block as an assert mask for <code>rx_digitalreset</code> and <code>rx_analogreset</code> to power down the lane.</p> <ul style="list-style-type: none"> <li>0 = Normal mode</li> <li>1 = Power down</li> </ul> <p><i>Note:</i> This status bit is not applicable for Intel Agilex and Intel Stratix 10 E-tile devices.</p>		
0	<code>csr_lane2_polarity</code>	<p>Set 1 to inverse lane 2 polarity.</p> <p>When set, the TX interface inverts the polarity of the TX data. You can use this bit to correct the polarity of differential pairs if the transmission circuitry or board layout mistakenly swaps the positive and negative signals.</p>	RW	0x0

**Table 32. lane\_ctrl\_3**

Lane control and assignment for Lane 3.

Offset: 0x10

Bit	Name	Description	Attribute	Reset
31:10	Reserved	Reserved	R	0x0
9:2	<code>r13</code>	Physical lane control reserve register	RW	0x0
1	<code>csr_lane3_powerdown</code>	<p>Power down control for lane 3.</p> <p>This register routes out of the IP as <code>csr_lane_powerdown[3]</code>. The transport layer (TL) uses this signal to indicate the fall back of the lanes (L) for run-time LMF support.</p> <p>To save power, route this signal to the Transceiver Reset Controller block as an assert mask for <code>rx_digitalreset</code> and <code>rx_analogreset</code> to power down the lane.</p> <ul style="list-style-type: none"> <li>0 = Normal mode</li> <li>1 = Power down</li> </ul> <p><i>Note:</i> This status bit is not applicable for Intel Agilex and Intel Stratix 10 E-tile devices.</p>	RW	0x0
0	<code>csr_lane3_polarity</code>	<p>Set 1 to inverse lane 3 polarity.</p> <p>When set, the TX interface inverts the polarity of the TX data. You can use this bit to correct the polarity of differential pairs if the transmission circuitry or board layout mistakenly swaps the positive and negative signals.</p>	RW	0x0



**Table 33. lane\_ctrl\_4**

Lane control and assignment for Lane 4.

Offset: 0x14

Bit	Name	Description	Attribute	Reset
31:10	Reserved	Reserved	R	0x0
9:2	rl4	Physical lane control reserve register	RW	0x0
1	csr_lane4_powerdown	<p>Power down control for lane 4.</p> <p>This register routes out of the IP as <code>csr_lane_powerdown[4]</code>. The transport layer (TL) uses this signal to indicate the fall back of the lanes (L) for run-time LMF support.</p> <p>To save power, route this signal to the Transceiver Reset Controller block as an assert mask for <code>rx_digitalreset</code> and <code>rx_analogreset</code> to power down the lane.</p> <ul style="list-style-type: none"> <li>0 = Normal mode</li> <li>1 = Power down</li> </ul> <p><i>Note:</i> This status bit is not applicable for Intel Agilex and Intel Stratix 10 E-tile devices.</p>	RW	0x0
0	csr_lane4_polarity	<p>Set 1 to inverse lane 4 polarity.</p> <p>When set, the TX interface inverts the polarity of the TX data. You can use this bit to correct the polarity of differential pairs if the transmission circuitry or board layout mistakenly swaps the positive and negative signals.</p>	RW	0x0

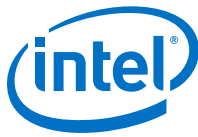
**Table 34. lane\_ctrl\_5**

Lane control and assignment for Lane 5.

Offset: 0x18

Bit	Name	Description	Attribute	Reset
31:10	Reserved	Reserved	R	0x0
9:2	rl5	Physical lane control reserve register	RW	0x0
1	csr_lane5_powerdown	<p>Power down control for lane 5.</p> <p>This register routes out of the IP as <code>csr_lane_powerdown[5]</code>. The transport layer (TL) uses this signal to indicate the fall back of the lanes (L) for run-time LMF support.</p> <p>To save power, route this signal to the Transceiver Reset Controller block as an assert mask for <code>rx_digitalreset</code> and <code>rx_analogreset</code> to power down the lane.</p> <ul style="list-style-type: none"> <li>0 = Normal mode</li> <li>1 = Power down</li> </ul>	RW	0x0

*continued...*



Bit	Name	Description	Attribute	Reset
		<i>Note:</i> This status bit is not applicable for Intel Agilex and Intel Stratix 10 E-tile devices.		
0	csr_lane5_polarity	Set 1 to inverse lane 5 polarity. When set, the TX interface inverts the polarity of the TX data. You can use this bit to correct the polarity of differential pairs if the transmission circuitry or board layout mistakenly swaps the positive and negative signals.	RW	0x0

**Table 35. lane\_ctrl\_6**

Lane control and assignment for Lane 6.

Offset: 0x1C

Bit	Name	Description	Attribute	Reset
31:10	Reserved	Reserved	R	0x0
9:2	rl6	Physical lane control reserve register	RW	0x0
1	csr_lane6_powerdown	Power down control for lane 6. This register routes out of the IP as <code>csr_lane_powerdown[6]</code> . The transport layer (TL) uses this signal to indicate the fall back of the lanes (L) for run-time LMF support. To save power, route this signal to the Transceiver Reset Controller block as an assert mask for <code>rx_digitalreset</code> and <code>rx_analogreset</code> to power down the lane. <ul style="list-style-type: none"> <li>0 = Normal mode</li> <li>1 = Power down</li> </ul> <i>Note:</i> This status bit is not applicable for Intel Agilex and Intel Stratix 10 E-tile devices.	RW	0x0
0	csr_lane6_polarity	Set 1 to inverse lane 6 polarity. When set, the TX interface inverts the polarity of the TX data. You can use this bit to correct the polarity of differential pairs if the transmission circuitry or board layout mistakenly swaps the positive and negative signals.	RW	0x0

**Table 36. lane\_ctrl\_7**

Lane control and assignment for Lane 7.

Offset: 0x20

Bit	Name	Description	Attribute	Reset
31:10	Reserved	Reserved	R	0x0
9:2	rl7	Physical lane control reserve register	RW	0x0
1	csr_lane7_powerdown	Power down control for lane 7.	RW	0x0

*continued...*





Bit	Name	Description	Attribute	Reset
		<p>This register routes out of the IP as <code>csr_lane_powerdown[7]</code>. The transport layer (TL) uses this signal to indicate the fall back of the lanes (L) for run-time LMF support.</p> <p>To save power, route this signal to the Transceiver Reset Controller block as an assert mask for <code>rx_digitalreset</code> and <code>rx_analogreset</code> to power down the lane.</p> <ul style="list-style-type: none"> <li>0 = Normal mode</li> <li>1 = Power down</li> </ul> <p><i>Note:</i> This status bit is not applicable for Intel Agilex and Intel Stratix 10 E-tile devices.</p>		
0	<code>csr_lane7_polarity</code>	<p>Set 1 to inverse lane 7 polarity.</p> <p>When set, the TX interface inverts the polarity of the TX data. You can use this bit to correct the polarity of differential pairs if the transmission circuitry or board layout mistakenly swaps the positive and negative signals.</p>	RW	0x0

**Table 37.** `dll_ctrl`

Data link layer (DLL) and TX control.

Offset: 0x50

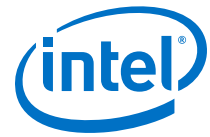
Bit	Name	Description	Attribute	Reset
31:17	Reserved	Reserved	R	0x0
16	<code>rd5</code>	DLL control reserve register 5	RW	0x0
15	<code>rd4</code>	DLL control reserve register 4	RW	0x0
14	<code>rd3</code>	DLL control reserve register 3	RW	0x0
13	<code>rd2</code>	DLL control reserve register 2	RW	0x0
12	<code>rd1</code>	DLL control reserve register 1	RW	0x0
11	<code>csr_reinit_rxsynchrise</code>	Control CGS state exit behavior during link reinitialization through <code>synchrn_sysref_ctrl</code> (0x54) <code>csr_link_reinit</code> .	RW	0x0

*continued...*



Bit	Name	Description	Attribute	Reset
		<ul style="list-style-type: none"> <li>0 = Exit CGS state without detected SYNC~ rise from DAC converter. (Default) If this mode is entered, transmitter shall transmit at least four /K28.5/ symbols and exit CGS state at next LMFC boundary during link re-initialization.</li> <li>1 = Exit CGS state only when detected SYNC~ rise from DAC converter. If this mode is entered, transmitter shall stays at CGS state and transmit /K28.5/ symbols until detected SYNC~ rise then exit CGS state at next LMFC boundary during link re-initialization.</li> </ul>		
10	test_ilas_loop	<p>Write 1 to this register will force the state machine to stay in Initial Lane Alignment Sequence (ILAS) state indefinitely after entry. ILAS Configuration will be transmitted during the second ILAS multiframe. The rest of the multiframe will have the start-of-multiframe character (/R/) followed by dummy data and end-of-multiframe (/A/). There are 2 modes of entry per JESD204B Specification, chapter 5.3.3.8.2:</p> <ul style="list-style-type: none"> <li>If this mode is entered when receiver initiates synchronization request, transmitter shall initiate CGS. Upon completion of CGS, transmitter shall repeatedly transmit ILAS.</li> <li>If there is no synchronization request upon test entry, transmitter shall transmit at least four /K28.5/ symbols. At the LMFC boundary, the transmitter shall repeatedly transmit ILAS.</li> </ul>	RW	0x0
9	csr_char_repl_disable	<p>Disable character replacement for debug purposes. When this bit is set, end-of-frame (/F/) and end-of-multiframe (/A/) character replacement will be disabled.</p> <ul style="list-style-type: none"> <li>0 = Character replacement enabled (Default)</li> <li>1 = Character replacement disabled. Used for debug purposes.</li> </ul>	RW	0x0
8:1	csr_ilas_multiframe	<p>The counter is binary value minus 1. ILAS required by subclass 1 and 2 consists of exactly 4 multiframes. However, configurations with multiple subclass 0 DAC devices may require additional multiframes to achieve lane alignment. Therefore, the length of ILAS shall be programmable from 4 up to 256 multiframes. When illegal values like 0/1/2 is set, the IP will still run as 4 multiframes.</p>	RW	0x0

*continued...*



Bit	Name	Description	Attribute	Reset
		<i>Note:</i> This counter value takes effect regardless of subclass setting. Do not to change this register for Subclass 1 and Subclass 2.		
0	csr_lane_sync_en	<p>Lane synchronization enable is required multiline alignment for a JESD204B link.</p> <ul style="list-style-type: none"> <li>0 = Lane synchronization is disabled. ILAS will be bypassed. The character replacement of user data during end of multiframe will be considered as end of frame.</li> <li>1 = Lane synchronization enabled (Default)</li> </ul> <p><i>Note:</i> For device that is classified as NMCD A-SL, you can disable lane synchronization. Set this bit to 1 for all other devices.</p>	RW	0x0

**Table 38.** syncn\_sysref\_ctrl

SYNC\_N and SYSREF control. Controls event sequencing related to SYNC\_N and SYSREF signals.

Offset: 0x54

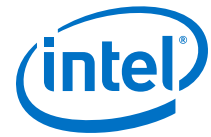
Bit	Name	Description	Attribute	Reset
31:21	Reserved	Reserved	R	0x0
20	csr_cgs_bypass_sysref	<p>This bit applies to Subclass 1 only. Enabling DLL states transition from Code Group Synchronization (CGS) to Initial Lane Alignment Sequence (ILAS) to bypass SYSREF single detect sampling. By default, the JESD204B IP will remain in CGS state until SYSREF is sampled. Once <code>csr_sysref_singledet</code> is cleared, then only the DLL state can transition from CGS to ILAS on the next LMFC tick.</p> <p>Write 1 to this register to allow the IP to exit out of CGS state without ensuring that at least one rising edge of SYSREF was sampled.</p> <p><i>Note:</i> This is a debug mode, where you can bypass SYSREF sampling if only a quick link up is required. Setting this bit to 1 may cause race condition between SYSREF sampling and CGS exit.</p>	RW	0x0
19:12	csr_lmfc_offset	<p>The Local Multiframe Clock (LMFC) offset is a binary value minus 1. Upon the detection of the rising edge of SYSREF in continuous mode or single detect mode, the LMFC counter will be reset to the value set in <code>csr_lmfc_offset</code>.</p>	RW	0x0

*continued...*



Bit	Name	Description	Attribute	Reset
		<p>The LMFC counter operates in link clock domain, therefore the legal value for the counter is from 0 to <math>((F_xK/4)-1)</math>. If you set an out-of-range value, the LMFC offset internally resets to 0.</p> <p><i>Note:</i> By default, the rising edge of <code>SYSREF</code> will reset the LMFC counter to 0. However, if the system design has large phase offset between the <code>SYSREF</code> sampled by the converter device and the FPGA, you can virtually shift the <code>SYSREF</code> edges by changing the LMFC offset reset value using this register.</p>		
11:7	Reserved	Reserved	R	0x0
6	rs4	SYNCRN and SYSREF control reserve register 4	RW	0x0
5	rs3	SYNCRN and SYSREF control reserve register 3	RW	0x0
4	rs2	SYNCRN and SYSREF control reserve register 2	RW	0x0
3	rs1	SYNCRN and SYSREF control reserve register 1	RW	0x0
2	csr_sysref_singledet	<p>This register enables LMFC realignment with a single sample of rising edge of <code>SYSREF</code>. The bit is auto-cleared by hardware once <code>SYSREF</code> is sampled. If you require <code>SYSREF</code> to be sampled again (due to link reset or reinitialization), you must set this bit again.</p> <p>This register also has another critical function. The JESD204B IP will never exit out of CGS unless at least a <code>SYSREF</code> edge is sampled. This is to prevent race condition between <code>SYSREF</code> being sampled and the exit of CGS to ILAS. If CGS transition to ILAS before the common <code>SYSREF</code> is sampled for both the IP and converter device, this would cause undeterministic latency as the transmitted ILAS is based on the free running LMFC counter coming out of reset.</p> <ul style="list-style-type: none"> <li>0 = Any rising edge of <code>SYSREF</code> will not reset the LMFC counter.</li> <li>1 = Resets the LMFC counter on the first rising edge of <code>SYSREF</code> and then clears this bit. (Default)</li> </ul>	RW	0x1

*continued...*



Bit	Name	Description	Attribute	Reset
		<p><i>Note:</i> Intel recommends that you use <code>csr_sysref_single</code> with <code>csr_sysref_always</code> even if you want to do <code>SYSREF</code> continuous detection mode. This is because this register is able to indicate whether <code>SYSREF</code> was ever sampled. This register also prevents race condition as mentioned above. Using only <code>SYSREF</code> single detect mode will not be able to detect incorrect <code>SYSREF</code> period.</p>		
1	<code>csr_sysref_always</code> <code>on</code>	<p>This register enables LMFC realignment at every rising edge of <code>SYSREF</code>. LMFC counter is reset when every <code>SYSREF</code> transition from 0 to 1 is detected.</p> <ul style="list-style-type: none"> <li>0 = Any rising edge of <code>SYSREF</code> will not reset the LMFC counter.</li> <li>1 = Continuously resets LMFC counter at every <code>SYSREF</code> rising edge.</li> </ul> <p><i>Note:</i> When this bit is set, the <code>SYSREF</code> period will be checked to ensure it never violates internal local multiframe period and this period can only be n-integer multiplied of <math>((F_xK)/4)</math>. If the <code>SYSREF</code> period is different from the local multiframe period, <code>tx_err</code> (0x60) <code>csr_sysref_lmfc_err</code> will be asserted and an interrupt will be triggered.</p> <p>If you want to change <code>SYSREF</code> period, this bit should be set to 0 first. After <code>SYSREF</code> clock has stabilized, this bit is set to 1 to sample the rising edges of the new <code>SYSREF</code>.</p>	RW	0x0
0	<code>csr_link_reinit</code>	<p>The JESD204B IP will reinitialize the link to enter Code Group Synchronization by transmitting / K28.5. The software will need to check that <code>SYNC_N tx_status0</code> (0x80) <code>csr_dev_syncn</code> is 1 before setting this register.</p> <p>This bit automatically clears once link reinitialization is entered by hardware.</p> <ul style="list-style-type: none"> <li>0 = No link reinit request (Default)</li> <li>1 = Reinitialize the link.</li> </ul>	RW	0x0



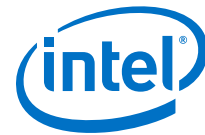
**Table 39. tx\_err**

This register logs errors detected in the FPGA IP. Each set bit in the register will generate interrupt, if enabled by corresponding bits in the TX Error Enable (*tx\_err\_enable (0x64)*). After servicing the interrupt, the software must clear the appropriate serviced interrupt status bit and ensure that no other interrupts are pending.

Offset: 0x60

Bit	Name	Description	Attribute	Reset
31:9	Reserved	Reserved	R	0x0
8	re4	TX error reserve status 4	RW	0x0
7	csr_pcfifo_empty_err	Detected 1 or more lanes of Phase Compensation FIFO is empty unexpectedly when the JESD204B link is running. <i>Note:</i> This status bit is not applicable for Intel Agilex and Intel Stratix 10 devices. <i>Note:</i> You MUST reset the JESD204B link if this bit is triggered. The transceiver channel, and the IP link reset must be applied.	RW1C	0x0
6	csr_pcfifo_full_err	Detected 1 or more lanes of Phase Compensation FIFO is full unexpectedly when the JESD204B link is running. <i>Note:</i> This status bit is not applicable for Intel Agilex and Intel Stratix 10 devices. <i>Note:</i> You MUST reset the JESD204B link if this bit is triggered. The transceiver channel, and the IP link reset must be applied.	RW1C	0x0
5	csr_pll_locked_err	Detected 1 or more lanes of PLL locked loose lock when the JESD204B link is running. <i>Note:</i> This status bit is not applicable for Intel Agilex and Intel Stratix 10 E-tile devices.	RW1C	0x0
4	csr_syncn_reinit_req	Receiver has requested reinitialization by asserting SYNC_N low for more than 5 frames and 9 octets. <i>Note:</i> Upon the detection of SYNC_N link reinitialization request from the receiver, the JESD204B IP enters Code Group Synchronization (CGS) and transmits continuous /K28.5/. If you want to regenerate and sample SYSREF, enabling this interrupt notifies the software that the receiver has requested for link reinitialization.	RW1C	0x0
3	csr_frame_data_invalid_err	This error bit is applicable only if you use the Intel FPGA transport layer in your design. This error bit will be asserted if the upstream component deasserts the jesd204_tx_data_valid signal at the Intel FPGA transport layer AV-ST bus.	RW1C	0x0

*continued...*



Bit	Name	Description	Attribute	Reset
		The transport layer expects the upstream device in the system to always send the valid data with zero latency when <code>jesd204_tx_data_ready</code> is asserted by the transport layer. <i>Note:</i> If this error detection is not required, you can tie off the <code>jesd204_tx_frame_error</code> signal to 0.		
2	<code>csr_dll_data_invalid_err</code>	This error bit will be asserted if the TX detects data invalid on the AV-ST bus when data is requested. By design, the JESD204B TX core expects the upstream device (JESD204B transport layer) to always send the valid data with zero latency when <code>jesd204_tx_data_ready</code> is asserted. <i>Note:</i> If this error detection is not required, you can tie off the <code>jesd204_tx_link_valid</code> signal to 1.	RW1C	0x0
1	<code>csr_sysref_lmfc_err</code>	When <code>syncn_sysref_ctrl</code> (0x54) <code>csr_sysref_alwayson</code> is set to 1, the LMFC counter checks whether the <code>SYSREF</code> period matches the LMFC counter where it is n-integer multiplier of the (F <sub>x</sub> K/4). If <code>SYSREF</code> period does not match the LMFC period, this bit will be asserted.	RW1C	0x0
0	<code>csr_syncn_err</code>	The JESD204B receiver indicates error through the <code>SYNCN_N</code> signal.	RW1C	0x0

Table 40. `tx_err_enable`

This register enables the error types that will generate interrupt. Setting 0 to the register bits will disable the specific error type from generating interrupt.

Offset: 0x64

Bit	Name	Description	Attribute	Reset
31:9	Reserved	Reserved	R	0x0
8	<code>re4_en</code>	TX error enable reserve 4	RW	0x1
7	<code>csr_pcfifo_empty_err_en</code>	Enable interrupt for Phase Compensation FIFO empty error	RW	0x1
6	<code>csr_pcfifo_full_err_en</code>	Enable interrupt for Phase Compensation FIFO full error	RW	0x1
5	<code>csr_pll_locked_err_en</code>	Enable interrupt for PLL loose lock error. <i>Note:</i> This status bit is not applicable for Intel Agilex and Intel Stratix 10 E-tile devices.	RW	0x1
4	<code>csr_syncn_reinit_req_en</code>	Enable interrupt for <code>SYNCN</code> reinit request.	RW	0x1

*continued...*



Bit	Name	Description	Attribute	Reset
3	csr_frame_data_invalid_err_en	Enable interrupt for transport layer data invalid error type.	RW	0x0
2	csr_dll_data_invalid_err_en	Enable interrupt for DLL data invalid error type.	RW	0x0
1	csr_sysref_lmfc_err_en	Enable interrupt for SYSREF LMFC error type.	RW	0x0
0	csr_syncn_err_en	Enable interrupt for SYNC_N error type.	RW	0x1

**Table 41. tx\_status0**

Monitor ports of internal signals and counter which will be useful for debug.

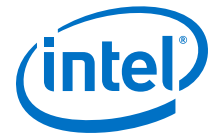
Offset: 0x80

*Note:* The bits that are compile-time specific are not configurable through register. You must recompile to change the value.)

Bit	Name	Description	Attribute	Reset
31:21	Reserved	Reserved	R	0x0
20:13	csr_dbg_adjcnt	Number of adjustment resolution steps of DAC LMFC in device link clock resolution. Applies to Subclass 2 only. <i>Note:</i> For Subclass 2 operations, the JESD204B IP calculates the phase of the SYNC_N deassertion from the receiver with respect to internal LMFC counter. Interrupt will be triggered with either tx_err (0x60) csr_syncn_err or csr_syncn_reinit_req set. This register along with csr_dbg_adjdir and csr_dbg_phadj latch the phase offset, direction and resolution based on phase detection using link clock. Hysteresis and device clock ratio calculation should be done in the software.	R	0x0
12	csr_dbg_adjdir	Adjustment direction of DAC LMFC to the nearest LMFC tick. Applies to Subclass 2 only. <ul style="list-style-type: none"> <li>0 = Advance</li> <li>1 = Delay</li> </ul>		0x0

*continued...*





Bit	Name	Description	Attribute	Reset
		<p><i>Note:</i> For Subclass 2 operations, the JESD204B IP calculates the phase of the <code>SYNC_N</code> deassertion from the receiver with respect to internal LMFC counter. Interrupt will be triggered with either <code>tx_err</code> (0x60) <code>csr_syncn_err</code> or <code>csr_syncn_reinit_req</code> set. This register along with <code>csr_dbg_phadj</code> and <code>csr_dbg_adjcnt</code> latch the phase offset, direction and resolution based on phase detection using link clock. Hysteresis and device clock ratio calculation should be done in the software.</p>		
11	<code>csr_dbg_phadj</code>	<p><code>SYNC_N</code> deassertion is not-in-phase with the internal LMFC counter. Applies to Subclass 2 only.</p> <ul style="list-style-type: none"> <li>0 = DAC LMFC is aligned to device LMFC.</li> <li>1 = DAC LMFC is NOT aligned to device LMFC</li> </ul> <p><i>Note:</i> For Subclass 2 operations, the JESD204B IP calculates the phase of the <code>SYNC_N</code> deassertion from the receiver with respect to internal LMFC counter. Interrupt will be triggered with either <code>tx_err</code> (0x60) <code>csr_syncn_err</code> or <code>csr_syncn_reinit_req</code> set. This register along with <code>csr_dbg_adjdir</code> and <code>csr_dbg_adjcnt</code> latch the phase offset, direction and resolution based on phase detection using link clock. Hysteresis and device clock ratio calculation should be done in the software.</p>		0x0
10:3	<code>csr_ilas_cnt</code>	This register is a binary minus 1 value. The counter value reflects on which number of ILAS multiframe the DLL state machine is in.	R	0x0
2	<code>csr_dll_state</code>	<p>Current state of data link layer (DLL).</p> <ul style="list-style-type: none"> <li>00 = Code Group Synchronization (CGS)</li> <li>01 = Initial Lane Alignment Sequence (ILAS)</li> <li>10 = User Data Mode</li> <li>11 = D21.5 test mode</li> </ul>	R	0x0
1:0	<code>csr_dev_syncn</code>	<p>Internal <code>SYNC_N</code> value.</p> <ul style="list-style-type: none"> <li>0 = Receiver is asserting synchronization request.</li> <li>1 = JESD204B link is out of synchronization.</li> </ul>	R	0x0



**Table 42. tx\_status1**

Monitor ports of internal signals and counter which will be useful for debug.

Offset: 0x84

Bit	Name	Description	Attribute	Reset
31:24	Reserved	Reserved	R	0x0
23	csr_lane7_tx_pcfifo_empty	TX phase compensation FIFO status empty flag for lane 7	R	0x0
22	csr_lane6_tx_pcfifo_empty	TX phase compensation FIFO status empty flag for lane 6	R	0x0
21	csr_lane5_tx_pcfifo_empty	TX phase compensation FIFO status empty flag for lane 5	R	0x0
20	csr_lane4_tx_pcfifo_empty	TX phase compensation FIFO status empty flag for lane 4	R	0x0
19	csr_lane3_tx_pcfifo_empty	TX phase compensation FIFO status empty flag for lane 3	R	0x0
18	csr_lane2_tx_pcfifo_empty	TX phase compensation FIFO status empty flag for lane 2	R	0x0
17	csr_lane1_tx_pcfifo_empty	TX phase compensation FIFO status empty flag for lane 1	R	0x0
16	csr_lane0_tx_pcfifo_empty	TX phase compensation FIFO status empty flag for lane 0	R	0x0
15:8	Reserved	Reserved	R	0x0
7	csr_lane7_tx_pcfifo_full	TX phase compensation FIFO status full flag for lane 7	R	0x0
6	csr_lane6_tx_pcfifo_full	TX phase compensation FIFO status full flag for lane 6	R	0x0
5	csr_lane5_tx_pcfifo_full	TX phase compensation FIFO status full flag for lane 5	R	0x0
4	csr_lane4_tx_pcfifo_full	TX phase compensation FIFO status full flag for lane 4	R	0x0
3	csr_lane3_tx_pcfifo_full	TX phase compensation FIFO status full flag for lane 3	R	0x0
2	csr_lane2_tx_pcfifo_full	TX phase compensation FIFO status full flag for lane 2	R	0x0
1	csr_lane1_tx_pcfifo_full	TX phase compensation FIFO status full flag for lane 1	R	0x0
0	csr_lane0_tx_pcfifo_full	TX phase compensation FIFO status full flag for lane 0	R	0x0

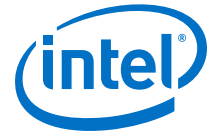
**Table 43. tx\_status2**

Monitor ports of internal signals and counter which will be useful for debug.

Offset: 0x88

Bit	Name	Description	Attribute	Reset
31:24	Reserved	Reserved	R	0x0
23	csr_lane7_pll_locked	PLL status for lane 7, indicates PLL is locked.	R	0x0

*continued...*



Bit	Name	Description	Attribute	Reset
		For Intel Agilex and Intel Stratix 10 E-tile devices, tie this register to 1'b1.		
22	csr_lane6_pll_locked	PLL status for lane 6, indicates PLL is locked. For Intel Agilex and Intel Stratix 10 E-tile devices, tie this register to 1'b1.	R	0x0
21	csr_lane5_pll_locked	PLL status for lane 5, indicates PLL is locked. For Intel Agilex and Intel Stratix 10 E-tile devices, tie this register to 1'b1.	R	0x0
20	csr_lane4_pll_locked	PLL status for lane 4, indicates PLL is locked. For Intel Agilex and Intel Stratix 10 E-tile devices, tie this register to 1'b1.	R	0x0
19	csr_lane3_pll_locked	PLL status for lane 3, indicates PLL is locked. For Intel Agilex and Intel Stratix 10 E-tile devices, tie this register to 1'b1.	R	0x0
18	csr_lane2_pll_locked	PLL status for lane 2, indicates PLL is locked. For Intel Agilex and Intel Stratix 10 E-tile devices, tie this register to 1'b1.	R	0x0
17	csr_lane1_pll_locked	PLL status for lane 1, indicates PLL is locked. For Intel Agilex and Intel Stratix 10 E-tile devices, tie this register to 1'b1.	R	0x0
16	csr_lane0_pll_locked	PLL status for lane 0, indicates PLL is locked. For bonded mode, the transceiver generates only one PLL locked signal. The single bit will be routed to lane 0 of PLL locked status. All other lanes will be tied off to 0. For non-bonded mode, PLL locked status will be per channel. The status will be routed to the respective PLL locked status per channel. For Intel Agilex and Intel Stratix 10 E-tile devices, tie this register to 1'b1.	R	0x0
15:8	Reserved	Reserved	R	0x0
7	csr_lane7_tx_cal_busy	Reconfig status for lane 7, indicates TX calibration is in progress. <i>Note:</i> This status bit is not applicable for Intel Agilex and Intel Stratix 10 E-tile devices.	R	0x0
6	csr_lane6_tx_cal_busy	Reconfig status for lane 6, indicates TX calibration is in progress. <i>Note:</i> This status bit is not applicable for Intel Agilex and Intel Stratix 10 E-tile devices.	R	0x0
5	csr_lane5_tx_cal_busy	Reconfig status for lane 5, indicates TX calibration is in progress. <i>Note:</i> This status bit is not applicable for Intel Agilex and Intel Stratix 10 E-tile devices.	R	0x0
<i>continued...</i>				



Bit	Name	Description	Attribute	Reset
4	csr_lane4_tx_cal_busy	Reconfig status for lane 4, indicates TX calibration is in progress. <i>Note:</i> This status bit is not applicable for Intel Agilex and Intel Stratix 10 E-tile devices.	R	0x0
3	csr_lane3_tx_cal_busy	Reconfig status for lane 3, indicates TX calibration is in progress. <i>Note:</i> This status bit is not applicable for Intel Agilex and Intel Stratix 10 E-tile devices.	R	0x0
2	csr_lane2_tx_cal_busy	Reconfig status for lane 2, indicates TX calibration is in progress. <i>Note:</i> This status bit is not applicable for Intel Agilex and Intel Stratix 10 E-tile devices.	R	0x0
1	csr_lane1_tx_cal_busy	Reconfig status for lane 1, indicates TX calibration is in progress. <i>Note:</i> This status bit is not applicable for Intel Agilex and Intel Stratix 10 E-tile devices.	R	0x0
0	csr_lane0_tx_cal_busy	Reconfig status for lane 0, indicates TX calibration is in progress. <i>Note:</i> This status bit is not applicable for Intel Agilex and Intel Stratix 10 E-tile devices.	R	0x0

**Table 44. tx\_status3**

TX status reserve..

Offset: 0x8C

Bit	Name	Description	Attribute	Reset
31:0	rs32	TX status reserve.	R	0x0

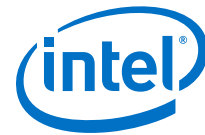
**Table 45. ilas\_data1**

Link control configuration transmitted during initial lane alignment sequence (ILAS).

Offset: 0x94

Bit	Name	Description	Attribute	Reset
31:24	csr_m	Link M. Number of converters per device (binary value minus 1). <i>Note:</i> Run-time reconfiguration is disabled for Intel Agilex and Intel Stratix 10 devices.	<ul style="list-style-type: none"> <li>RW for all devices except Intel Agilex and Intel Stratix 10</li> <li>RO for Intel Agilex and Intel Stratix 10 devices</li> </ul>	Reset to parameter value per IP generation.
23:21	Reserved	Reserved	R	0x0

**continued...**



Bit	Name	Description	Attribute	Reset
20:16	csr_k	Link K. Number of frames per multiframe (binary value minus 1). A multiframe is defined as a group of K successive frames where K is between 1 and 32 and such that the number of octets per multiframe is between 17 and 1024. The IP requires that FxK must be divisible by 4. <i>Note:</i> Run-time reconfiguration is disabled for Intel Agilex and Intel Stratix 10 devices.	<ul style="list-style-type: none"> <li>RW for all devices except Intel Agilex and Intel Stratix 10</li> <li>RO for Intel Agilex and Intel Stratix 10 devices</li> </ul>	Reset to parameter value per IP generation.
15:8	csr_f	Link F. Number of octets per frame (binary value minus 1). <i>Note:</i> Run-time reconfiguration is disabled for Intel Agilex and Intel Stratix 10 devices.	<ul style="list-style-type: none"> <li>RW for all devices except Intel Agilex and Intel Stratix 10</li> <li>RO for Intel Agilex and Intel Stratix 10 devices</li> </ul>	Reset to parameter value per IP generation.
7	csr_scr_en	Enable or disable descrambler. <ul style="list-style-type: none"> <li>0 = Disable descrambler</li> <li>1 = Enable descrambler</li> </ul> <i>Note:</i> Run-time reconfiguration is disabled for Intel Agilex and Intel Stratix 10 devices.	<ul style="list-style-type: none"> <li>RW for all devices except Intel Agilex and Intel Stratix 10</li> <li>RO for Intel Agilex and Intel Stratix 10 devices</li> </ul>	Reset to parameter value per IP generation.
6:5	Reserved	Reserved	R	0x0
4:0	csr_l	Link L. Number of lanes per converter (binary value minus 1). <i>Note:</i> Run-time reconfiguration is disabled for Intel Agilex and Intel Stratix 10 devices.	<ul style="list-style-type: none"> <li>RW for all devices except Intel Agilex and Intel Stratix 10</li> <li>RO for Intel Agilex and Intel Stratix 10 devices</li> </ul>	Reset to parameter value per IP generation.

**Table 46. ilas\_data2**

Link control configuration transmitted during initial lane alignment sequence (ILAS).

Offset: 0x98

Bit	Name	Description	Attribute	Reset
31	csr_hd	Link HD. High density format. <i>Note:</i> Run-time reconfiguration is disabled for Intel Agilex and Intel Stratix 10 devices.	<ul style="list-style-type: none"> <li>RW for all devices except Intel Agilex and Intel Stratix 10</li> <li>RO for Intel Agilex and Intel Stratix 10 devices</li> </ul>	Reset to parameter value per IP generation.
30:29	Reserved	Reserved	R	0x0

*continued...*



Bit	Name	Description	Attribute	Reset
28:24	csr_cf	<p>Link CF. Number of control words per frame clock period per link</p> <ul style="list-style-type: none"> <li>CF = L is encoded as 31: control words on all lanes.</li> <li>CF = 31 can only occur when L = 31</li> </ul> <p><i>Note:</i> Run-time reconfiguration is disabled for Intel Agilex and Intel Stratix 10 devices.</p>	<ul style="list-style-type: none"> <li>RW for all devices except Intel Agilex and Intel Stratix 10</li> <li>RO for Intel Agilex and Intel Stratix 10 devices</li> </ul>	Reset to parameter value per IP generation.
23:21	csr_jesdv	<p>JESD204x version.</p> <ul style="list-style-type: none"> <li>000 = JESD204A</li> <li>001 = JESD204B</li> </ul> <p><i>Note:</i> Run-time reconfiguration is disabled for Intel Stratix 10 devices.</p>	<ul style="list-style-type: none"> <li>RW for all devices except Intel Stratix 10</li> <li>RO for Intel Stratix 10 devices</li> </ul>	0x1
20:16	csr_s	<p>Link S. Number of samples per converter per frame cycle (binary value minus 1).</p> <p><i>Note:</i> Run-time reconfiguration is disabled for Intel Stratix 10 devices.</p>	<ul style="list-style-type: none"> <li>RW for all devices except Intel Agilex and Intel Stratix 10</li> <li>RO for Intel Agilex and Intel Stratix 10 devices</li> </ul>	Reset to parameter value per IP generation.
15:13	csr_subclassv	<p>Device subclass version</p> <ul style="list-style-type: none"> <li>000 = Subclass 0</li> <li>001 = Subclass 1</li> <li>010 = Subclass 2</li> </ul> <p><i>Note:</i> Run-time reconfiguration is disabled for Intel Agilex and Intel Stratix 10 devices.</p>	<ul style="list-style-type: none"> <li>RW for all devices except Intel Agilex and Intel Stratix 10</li> <li>RO for Intel Agilex and Intel Stratix 10 devices</li> </ul>	Reset to parameter value per IP generation.
12:8	csr_np	<p>Link NP. Total number of bits per sample (binary value minus 1).</p> <p><i>Note:</i> Run-time reconfiguration is disabled for Intel Agilex and Intel Stratix 10 devices.</p>	<ul style="list-style-type: none"> <li>RW for all devices except Intel Agilex and Intel Stratix 10</li> <li>RO for Intel Agilex and Intel Stratix 10 devices</li> </ul>	Reset to parameter value per IP generation.

*continued...*



Bit	Name	Description	Attribute	Reset
7:6	csr_cs	Link CS. Number of control bits per sample. <i>Note:</i> Run-time reconfiguration is disabled for Intel Agilex and Intel Stratix 10 devices.	<ul style="list-style-type: none"> <li>RW for all devices except Intel Agilex and Intel Stratix 10</li> <li>RO for Intel Agilex and Intel Stratix 10 devices</li> </ul>	Reset to parameter value per IP generation.
5	Reserved	Reserved	R	0x0
4:0	csr_n	Link N. Converter resolution (binary value minus 1). <i>Note:</i> Run-time reconfiguration is disabled for Intel Agilex and Intel Stratix 10 devices.	<ul style="list-style-type: none"> <li>RW for all devices except Intel Agilex and Intel Stratix 10</li> <li>RO for Intel Agilex and Intel Stratix 10 devices</li> </ul>	Reset to parameter value per IP generation.

**Table 47. ilas\_data3**

Link control configuration transmitted during initial lane alignment sequence (ILAS).

Offset: 0x9C

Bit	Name	Description	Attribute	Reset
31	csr_phadj	Phase adjustment request of DAC LMFC. The register is auto-cleared by the hardware after sending ILAS 2nd multiframe. Applies to Subclass 2 only.	RW	Reset to parameter value per IP generation.
30	csr_adjdir	Adjustment direction of DAC LMFC. The register is auto-cleared by the hardware after sending ILAS 2nd multiframe. Applies to Subclass 2 only. <ul style="list-style-type: none"> <li>0 = Advance</li> <li>1 = Delay</li> </ul>	RW	Reset to parameter value per IP generation.
29:20	Reserved	Reserved	R	0x0
19:16	csr_f	Number of adjustment resolution steps of DAC LMFC. The register is auto-cleared by the hardware after sending ILAS 2nd multiframe. Applies to Subclass 2 only.	RW	Reset to parameter value per IP generation.
15:8	csr_rsvd2	ILAS reserved 2 bytes.	RW	0x00
7:0	csr_rsvd1	ILAS reserved 1 bytes.	RW	0x00

**Table 48. ilas\_data4**

Link control configuration transmitted during initial lane alignment sequence (ILAS).

Offset: 0xA0

Bit	Name	Description	Attribute	Reset
31:29	Reserved	Reserved	R	0x0
28:24	csr_lid_l3	Lane Identification for lane 3 transmitted during ILAS.	RW	Reset to parameter value per IP generation.
23:21	Reserved	Reserved	R	0x0
20:16	csr_lid_l2	Lane Identification for lane 2 transmitted during ILAS.	RW	Reset to parameter value per IP generation.
15:13	Reserved	Reserved	R	0x0
12:8	csr_lid_l1	Lane Identification for lane 1 transmitted during ILAS.	RW	Reset to parameter value per IP generation.
7:5	Reserved	Reserved	R	0x0
4:0	csr_lid_l0	Lane Identification for lane 0 transmitted during ILAS.	RW	Reset to parameter value per IP generation.

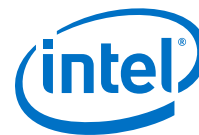
**Table 49. ilas\_data5**

Link control configuration transmitted during initial lane alignment sequence (ILAS).

Offset: 0xA4

Bit	Name	Description	Attribute	Reset
31:29	Reserved	Reserved	R	0x0
28:24	csr_lid_l7	Lane Identification for lane 7 transmitted during ILAS.	RW	Reset to parameter value per IP generation.
23:21	Reserved	Reserved	R	0x0
20:16	csr_lid_l6	Lane Identification for lane 6 transmitted during ILAS.	RW	Reset to parameter value per IP generation.
15:13	Reserved	Reserved	R	0x0
12:8	csr_lid_l5	Lane Identification for lane 5 transmitted during ILAS.	RW	Reset to parameter value per IP generation.
7:5	Reserved	Reserved	R	0x0
4:0	csr_lid_l4	Lane Identification for lane 4 transmitted during ILAS.	RW	Reset to parameter value per IP generation.



**Table 50. ilas\_data8**

Link control configuration transmitted during initial lane alignment sequence (ILAS).

Offset: 0xB0

Bit	Name	Description	Attribute	Reset
31:24	csr_fchk_l3	ILAS checksum lane 3. Checksum is the modulo 256 of parameters listed ILAS configuration data.	RW	Reset to parameter value per IP generation.
23:16	csr_fchk_l2	ILAS checksum lane 2. Checksum is the modulo 256 of parameters listed ILAS configuration data.	RW	Reset to parameter value per IP generation.
15:8	csr_fchk_l1	ILAS checksum lane 1. Checksum is the modulo 256 of parameters listed ILAS configuration data.	RW	Reset to parameter value per IP generation.
7:0	csr_fchk_l0	ILAS checksum lane 0. Checksum is the modulo 256 of parameters listed ILAS configuration data.	RW	Reset to parameter value per IP generation.

**Table 51. ilas\_data9**

Link control configuration transmitted during initial lane alignment sequence (ILAS).

Offset: 0xB4

Bit	Name	Description	Attribute	Reset
31:10	csr_fchk_l7	ILAS checksum lane 7. Checksum is the modulo 256 of parameters listed ILAS configuration data.	RW	Reset to parameter value per IP generation.
23:16	csr_fchk_l6	ILAS checksum lane 6. Checksum is the modulo 256 of parameters listed ILAS configuration data.	RW	Reset to parameter value per IP generation.
15:8	csr_fchk_l5	ILAS checksum lane 5. Checksum is the modulo 256 of parameters listed ILAS configuration data.	RW	Reset to parameter value per IP generation.
7:0	csr_fchk_l4	ILAS checksum lane 4. Checksum is the modulo 256 of parameters listed ILAS configuration data.	RW	Reset to parameter value per IP generation.

**Table 52. ilas\_data12**

Link control configuration transmitted during initial lane alignment sequence (ILAS).

Offset: 0xC0

Bit	Name	Description	Attribute	Reset
31:10	Reserved	Reserved	R	0x0
9:2	csr_fxk_h	Upper bits of FxK[8:2]. This is a binary value minus 1. Link F multiply with Link K must be divisible by 4. <i>Note:</i> The IP runs on 32-bit data width boundary per channel, so you must always ensure that FxK must be divisible by 4.	<ul style="list-style-type: none"> <li>RW for all devices except Intel Agilex and Intel Stratix 10</li> <li>RO for Intel Agilex and Intel Stratix 10 devices</li> </ul>	Reset to parameter value per IP generation.

*continued...*



Bit	Name	Description	Attribute	Reset
		<i>Note:</i> Run-time reconfiguration is disabled for Intel Agilex and Intel Stratix 10 devices.		
1:0	csr_fxk_l	Lower bits of FxK[1:0]. This is a binary value minus 1. Link F multiply with Link K must be divisible by 4. <i>Note:</i> The IP runs on 32-bit data width boundary per channel, so you must always ensure that FxK must be divisible by 4. FxK (in binary value minus 1) always results to a value of 2'b11 in the lower 2 bits.	R	0x3

**Table 53. tx\_test**

JESD204 test control.

Offset: 0xD0

Bit	Name	Description	Attribute	Reset
31:4	Reserved	Reserved	R	0x0
3:0	csr_tx_testmode	b0xxx is reserved for the JESD204B IP and 'b1xxx is reserved for external components out of the JESD204B IP. JESD204B IP test mode: <ul style="list-style-type: none"> <li>• 0000 = No test (Default)</li> <li>• 0001 = K28.5</li> <li>• 0010 = D21.5</li> </ul> JESD204B IP reference design test mode: <ul style="list-style-type: none"> <li>• 1000 = Alternating Checkerboard</li> <li>• 1001 = Ramp</li> <li>• 1010 = PRBS</li> </ul>	RW	0x0

**Table 54. user\_test\_pattern\_a**

Test pattern per sample per converter.

Offset: 0xD4

Bit	Name	Description	Attribute	Reset
31:16	test_pattern1	User test pattern 1.	RW	0x0000
15:0	test_pattern0	User test pattern 0.	RW	0x0000

**Table 55. user\_test\_pattern\_b**

Test pattern per sample per converter.

Offset: 0xD8

Bit	Name	Description	Attribute	Reset
31:16	test_pattern3	User test pattern 3.	RW	0x0000
15:0	test_pattern2	User test pattern 2.	RW	0x0000



**Table 56. user\_test\_pattern\_c**

Test pattern per sample per converter.

Offset: 0xDC

Bit	Name	Description	Attribute	Reset
31:16	test_pattern5	User test pattern 5.	RW	0x0000
15:0	test_pattern4	User test pattern 4.	RW	0x0000

**Table 57. user\_test\_pattern\_d**

Test pattern per sample per converter.

Offset: 0xE0

Bit	Name	Description	Attribute	Reset
31:16	test_pattern7	User test pattern 7.	RW	0x0000
15:0	test_pattern6	User test pattern 6.	RW	0x0000

### 4.7.3. Receiver Registers

**Table 58. lane\_ctrl\_common**

Common lane control and assignment. The common lane control applies to all lanes in the link.

Offset: 0x0

*Note:* The bits that are compile-time specific are not configurable through register. You must recompile to change the value.)

Bit	Name	Description	Attribute	Reset
31:3	Reserved	Reserved	R	0x0
2	rl	Physical lane control reserve register	RW	0x0
1	csr_bit_reversal	<p>Bit reversal for LSB/MSB first serialization. This is a compile-time option which needs to be set before IP generation.</p> <ul style="list-style-type: none"> <li>0 = LSB-first serialization</li> <li>1 = MSB-first serialization</li> </ul> <p><i>Note:</i> JESD204B converter device may support either MSB-first serialization or LSB-first serialization.</p> <p>You must set both <code>csr_byte_reversal</code> and <code>csr_bit_reversal</code> bits to 1 when generating the IP.</p> <p>When <code>csr_bit_reversal</code> = 1, the word aligner reverses the RX parallel data bits upon receiving the PMA deserialized data.</p>	R	Compile-time specific

*continued...*



Bit	Name	Description	Attribute	Reset
		For example; in 20-bit mode; D[19:0] is rewired to D[0:19] and in 40-bit mode; D[39:0] is rewired to D[0:39].		
0	csr_byte_reversal	<p>Byte reversal for LSB/MSB first serialization. This is a compile-time option which needs to be set before IP generation.</p> <ul style="list-style-type: none"> <li>0 = LSB-first serialization Byte order = {octet3, octet2, octet1, octet0}</li> <li>1 = MSB-first serialization Byte order = {octet0, octet1, octet2, octet3}</li> </ul> <p><i>Note:</i> JESD204B converter device may support either MSB-first serialization or LSB-first serialization.</p> <p>When <code>csr_byte_reversal = 1</code>, the word aligner reverses the byte order.</p>	R	Compile-time specific

**Table 59. lane\_ctrl\_0**

Lane control and assignment for lane 0.

Offset: 0x4

Bit	Name	Description	Attribute	Reset
31:3	Reserved	Reserved	R	0x0
2	csr_alllanes_pattern_align_en	<p>Enables word alignment to the specified pattern boundary alignment during link initialization. You should set this bit to 1 in normal operations.</p> <p><i>Note:</i> You can disable this bit to debug bit slip error.</p>	RW	0x1
1	csr_lane0_powerdown	<p>Power down control for lane 0. This register routes out of the IP as <code>csr_lane_powerdown[0]</code>. The transport layer (TL) uses this signal to indicate the fall back of the lanes (L) for run-time LMF support.</p> <p>To save power, route this signal to the Transceiver Reset Controller block as an assert mask for <code>rx_digitalreset</code> and <code>rx_analogreset</code> to power down the lane.</p> <ul style="list-style-type: none"> <li>0 = Normal mode</li> <li>1 = Power down</li> </ul>	RW	0x0
0	csr_lane0_polarity	<p>Set 1 to inverse lane 0 polarity. When set, the RX interface inverts the polarity of the RX data. You can use this bit to correct the polarity of differential pairs if the transmission circuitry or board layout mistakenly swaps the positive and negative signals.</p>	RW	0x0



**Table 60. lane\_ctrl\_1**

Lane control and assignment for lane 1.

Offset: 0xC

Bit	Name	Description	Attribute	Reset
31:3	Reserved	Reserved	R	0x0
2	r1	Physical lane control reserve register.	RW	0x1
1	csr_lane1_powerdown	<p>Power down control for lane 1.</p> <p>This register routes out of the IP as <code>csr_lane_powerdown[1]</code>. The transport layer (TL) uses this signal to indicate the fall back of the lanes (L) for run-time LMF support.</p> <p>To save power, route this signal to the Transceiver Reset Controller block as an assert mask for <code>rx_digitalreset</code> and <code>rx_analogreset</code> to power down the lane.</p> <ul style="list-style-type: none"> <li>0 = Normal mode</li> <li>1 = Power down</li> </ul>	RW	0x0
0	csr_lane1_polarity	<p>Set 1 to inverse lane 1 polarity.</p> <p>When set, the RX interface inverts the polarity of the RX data. You can use this bit to correct the polarity of differential pairs if the transmission circuitry or board layout mistakenly swaps the positive and negative signals.</p>	RW	0x0

**Table 61. lane\_ctrl\_2**

Lane control and assignment for lane 2.

Offset: 0xC

Bit	Name	Description	Attribute	Reset
31:3	Reserved	Reserved	R	0x0
2	r2	Physical lane control reserve register.	RW	0x1
1	csr_lane2_powerdown	<p>Power down control for lane 2.</p> <p>This register routes out of the IP as <code>csr_lane_powerdown[2]</code>. The transport layer (TL) uses this signal to indicate the fall back of the lanes (L) for run-time LMF support.</p> <p>To save power, route this signal to the Transceiver Reset Controller block as an assert mask for <code>rx_digitalreset</code> and <code>rx_analogreset</code> to power down the lane.</p> <ul style="list-style-type: none"> <li>0 = Normal mode</li> <li>1 = Power down</li> </ul>	RW	0x0
0	csr_lane2_polarity	<p>Set 1 to inverse lane 2 polarity.</p> <p>When set, the RX interface inverts the polarity of the RX data. You can use this bit to correct the polarity of differential pairs if the transmission circuitry or board layout mistakenly swaps the positive and negative signals.</p>	RW	0x0

**Table 62. lane\_ctrl\_3**

Lane control and assignment for lane 3.

Offset: 0x10

Bit	Name	Description	Attribute	Reset
31:3	Reserved	Reserved	R	0x0
2	rl3	Physical lane control reserve register.	RW	0x1
1	csr_lane3_powerdown	<p>Power down control for lane 3. This register routes out of the IP as <code>csr_lane_powerdown[3]</code>. The transport layer (TL) uses this signal to indicate the fall back of the lanes (L) for run-time LMF support.</p> <p>To save power, route this signal to the Transceiver Reset Controller block as an assert mask for <code>rx_digitalreset</code> and <code>rx_analogreset</code> to power down the lane.</p> <ul style="list-style-type: none"> <li>0 = Normal mode</li> <li>1 = Power down</li> </ul>	RW	0x0
0	csr_lane3_polarity	<p>Set 1 to inverse lane 3 polarity. When set, the RX interface inverts the polarity of the RX data. You can use this bit to correct the polarity of differential pairs if the transmission circuitry or board layout mistakenly swaps the positive and negative signals.</p>	RW	0x0

**Table 63. lane\_ctrl\_4**

Lane control and assignment for lane 4.

Offset: 0x14

Bit	Name	Description	Attribute	Reset
31:3	Reserved	Reserved	R	0x0
2	rl4	Physical lane control reserve register.	RW	0x1
1	csr_lane4_powerdown	<p>Power down control for lane 4. This register routes out of the IP as <code>csr_lane_powerdown[4]</code>. The transport layer (TL) uses this signal to indicate the fall back of the lanes (L) for run-time LMF support.</p> <p>To save power, route this signal to the Transceiver Reset Controller block as an assert mask for <code>rx_digitalreset</code> and <code>rx_analogreset</code> to power down the lane.</p> <ul style="list-style-type: none"> <li>0 = Normal mode</li> <li>1 = Power down</li> </ul>	RW	0x0
0	csr_lane4_polarity	<p>Set 1 to inverse lane 4 polarity. When set, the RX interface inverts the polarity of the RX data. You can use this bit to correct the polarity of differential pairs if the transmission circuitry or board layout mistakenly swaps the positive and negative signals.</p>	RW	0x0

**Table 64. lane\_ctrl\_5**

Lane control and assignment for lane 5.

Offset: 0x18

Bit	Name	Description	Attribute	Reset
31:3	Reserved	Reserved	R	0x0
2	rl5	Physical lane control reserve register.	RW	0x1
1	csr_lane5_powerdown	<p>Power down control for lane 5.</p> <p>This register routes out of the IP as <code>csr_lane_powerdown[2]</code>. The transport layer (TL) uses this signal to indicate the fall back of the lanes (L) for run-time LMF support.</p> <p>To save power, route this signal to the Transceiver Reset Controller block as an assert mask for <code>rx_digitalreset</code> and <code>rx_analogreset</code> to power down the lane.</p> <ul style="list-style-type: none"> <li>0 = Normal mode</li> <li>1 = Power down</li> </ul>	RW	0x0
0	csr_lane5_polarity	<p>Set 1 to inverse lane 5 polarity.</p> <p>When set, the RX interface inverts the polarity of the RX data. You can use this bit to correct the polarity of differential pairs if the transmission circuitry or board layout mistakenly swaps the positive and negative signals.</p>	RW	0x0

**Table 65. lane\_ctrl\_6**

Lane control and assignment for lane 6.

Offset: 0x1C

Bit	Name	Description	Attribute	Reset
31:3	Reserved	Reserved	R	0x0
2	rl6	Physical lane control reserve register.	RW	0x1
1	csr_lane6_powerdown	<p>Power down control for lane 6.</p> <p>This register routes out of the IP as <code>csr_lane_powerdown[6]</code>. The transport layer (TL) uses this signal to indicate the fall back of the lanes (L) for run-time LMF support.</p> <p>To save power, route this signal to the Transceiver Reset Controller block as an assert mask for <code>rx_digitalreset</code> and <code>rx_analogreset</code> to power down the lane.</p> <ul style="list-style-type: none"> <li>0 = Normal mode</li> <li>1 = Power down</li> </ul>	RW	0x0
0	csr_lane6_polarity	<p>Set 1 to inverse lane 6 polarity.</p> <p>When set, the RX interface inverts the polarity of the RX data. You can use this bit to correct the polarity of differential pairs if the transmission circuitry or board layout mistakenly swaps the positive and negative signals.</p>	RW	0x0

**Table 66. lane\_ctrl\_7**

Lane control and assignment for lane 7.

Offset: 0x20

Bit	Name	Description	Attribute	Reset
31:3	Reserved	Reserved	R	0x0
2	rl7	Physical lane control reserve register.	RW	0x1
1	csr_lane7_powerdown	Power down control for lane 6. This register routes out of the IP as <code>csr_lane_powerdown[7]</code> . The transport layer (TL) uses this signal to indicate the fall back of the lanes (L) for run-time LMF support. To save power, route this signal to the Transceiver Reset Controller block as an assert mask for <code>rx_digitalreset</code> and <code>rx_analogreset</code> to power down the lane. <ul style="list-style-type: none"> <li>0 = Normal mode</li> <li>1 = Power down</li> </ul>	RW	0x0
0	csr_lane7_polarity	Set 1 to inverse lane 7 polarity. When set, the RX interface inverts the polarity of the RX data. You can use this bit to correct the polarity of differential pairs if the transmission circuitry or board layout mistakenly swaps the positive and negative signals.	RW	0x0

**Table 67. dll\_ctrl**

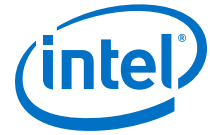
Data link layer (DLL) and RX control.

Offset: 0x50

Bit	Name	Description	Attribute	Reset
31:17	Reserved	Reserved	R	0x0
16	rd4	DLL control reserve register 4.	RW	0x0
15	rd3	DLL control reserve register 3.	RW	0x0
14	rd2	DLL control reserve register 2.	RW	0x0
13	rd1	DLL control reserve register 1.	RW	0x0
12	csr_link_reinit_disable	Disable link reinitialization for all error conditions except for Code Group error. This is a global link reinitialization disable that overrides register <code>rx_err_link_reinit (0x78)</code> . <ul style="list-style-type: none"> <li>0 = Enable link reinitialization during error condition (Default)</li> <li>1 = Disable link reinitialization for all error conditions except for Code Group Error.</li> </ul>	RW	0x0
11	rd0	DLL control reserve register 0.	RW	0x0
10:7	csr_ilas_data_sel	JESD204B link configuration data transmitted during the 2nd ILAS multiframe is latched per lane.	RW	0x0

*continued...*





Bit	Name	Description	Attribute	Reset
		<p>This register is used to select desired lane's link configuration data to be routed to the <code>ilas_octet0</code> (0xa0), <code>ilas_octet1</code> (0xa4), <code>ilas_octet2</code> (0xa8), and <code>ilas_octet3</code> (0xac) registers. The link configuration data in <code>ilas_octet0</code> to <code>ilas_octet3</code> will be invalid (all zeros) if invalid lane is selected.</p> <p>4'b0000 = lane 0 ILAS link configuration data, 4'b0001 = lane 1 ILAS link configuration data, ...            4'b0111 = lane 7 ILAS link configuration data.</p>		
6:3	Reserved	Reserved	R	0x0
2	<code>csr_dis_lane_align_det</code>	<p>In normal operation, the JESD204B IP is required to detect end-of-multiframe /A/ character and checks for lane alignment. You can disable this check for debug purposes.</p> <ul style="list-style-type: none"> <li>0 = Enable lane alignment detection (Default)</li> <li>1 = Disable lane alignment detection</li> </ul>	RW	0x0
1	<code>csr_dis_frame_align_det</code>	<p>In normal operation, JESD204B IP is required to detect end-of-frame /F/ character and checks for frame alignment. You can disable this check for debug purposes.</p> <ul style="list-style-type: none"> <li>0 = Enable frame alignment detection (Default)</li> <li>1 = Disable frame alignment detection</li> </ul>	RW	0x0
0	<code>csr_lane_sync_en</code>	<p>Lane synchronization enable is required multilane alignment for a JESD204B link.</p> <ul style="list-style-type: none"> <li>0 = Disable lane synchronization is disabled.</li> </ul> <p>The IP expects the transmit device to bypass ILAS, and the DLL state transition from CGS to USER DATA and checks for this transition to release the data from the elastic buffer.</p> <ul style="list-style-type: none"> <li>1 = Enable lane synchronization (Default).</li> </ul> <p>The IP expects the DLL state from the transmit device to transition from CGS to ILAS then to USER DATA and checks from ILAS.</p> <p><i>Note:</i> For device that is classified as NMCA-SL, lane synchronization can be disabled. This bit has to be set to 1 for all other devices.</p>	RW	0x0



**Table 68. syncn\_sysref\_ctrl**

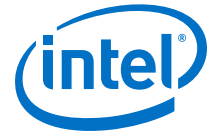
SYSREF control.

Offset: 0x54

*Note:* The bits that are compile-time specific are not configurable through register. You must recompile to change the value.)

Bit	Name	Description	Attribute	Reset
31:25	Reserved	Reserved	R	0x0
24:21	csr_syncn_delay	This 4-bit register extends SYNC_N assertion (low state) by delaying the deassertion. The legal value is 0 to 15; with 0 indicating no additional delay on SYNC_N deassertion.  For Subclass 0, the value indicates the number of link clocks SYNC_N will be extended.  For Subclass 1 and 2, the value indicates the number of multiframes SYNC_N will be extended.	RW	0x00
20	csr_cgs_bypass_sysref	This bit applies to Subclass 1 only. Enabling DLL states transition from Code Group Synchronization (CGS) to Initial Lane Alignment Sequence (ILAS) to bypass SYSREF single detect sampling.  By default, the JESD204B IP remains in CGS state (asserting SYNC_N) until SYSREF is sampled. Once csr_sysref_singledet is cleared, then only the DLL state can transition from CGS to ILAS on the next LMFC tick.  Write 1 to this register to allow the IP to exit out of CGS state without ensuring that at least one rising edge of SYSREF was sampled.  <i>Note:</i> This is a debug mode, where you can bypass SYSREF sampling if only a quick link up is required. Setting this bit to 1 may cause race condition between SYSREF sampling and CGS exit.	RW	0x0
19:12	csr_lmfc_offset	The LMFC offset is binary value minus 1. Upon the detection of the rising edge of SYSREF in continuous mode or single detect mode, the LMFC counter resets to the value set in csr_lmfc_offset.  LMFC counter operates in link clock domain, therefore the legal value for the counter is from 0 to ((F <sub>XK</sub> /4)-1). If an out-of-range value is set, the LMFC offset internally resets to 0.  By default, the rising edge of SYSREF will reset the LMFC counter to 0. However, if the system design has large phase offset between the SYSREF sampled by the converter device and	RW	0x00

*continued...*



Bit	Name	Description	Attribute	Reset
		the FPGA, you can virtually shift the <code>SYSREF</code> edges by changing the LMFC offset reset value using this register.		
11	<code>csr_force_rbd_release</code>	Setting this bit will force RBD elastic buffer to be released immediately when the latest arrival lane arrived in the system.  It indirectly forces <code>csr_rbd_offset</code> to <code>rx_status0</code> (0x80) <code>csr_rbd_count</code> . This register overrides <code>csr_rbd_offset</code> .	RW	0x0
10:3	<code>csr_rbd_offset</code>	This is a binary minus 1 value. RX elastic buffer will align the data from multiple lanes of the link and release the buffer at the LMFC boundary ( <code>csr_rbd_offset = 0</code> ).  This register provides flexibility for an early RBD release opportunity. Legal value of RBD offset is from $((F_xK/4)-1)$ down to 0 as it is aligned in number of link clocks. If <code>csr_rbd_offset</code> is set out of the legal value, the RBD elastic buffer will be immediately released.  <i>Note:</i> In Subclass 1, the earliest lane data right up to the latest lane data will be stored in the elastic buffer. The data is deskewed and release at the LMFC boundary where ( <code>csr_rbd_offset = 0</code> ). The position of the latest lane arrival with respect to the LMFC internal counter will be reported in register <code>rx_status0</code> (0x80) <code>csr_rbd_count</code> . Set a safe RBD release in this register to ensure deterministic latency in power cycle mode. Refer to the application note on deterministic latency for more information.	RW	0x0
2	<code>csr_sysref_singledet</code>	This register enables LMFC realignment with a single sample of rising edge of <code>SYSREF</code> . The bit is auto-cleared by hardware once <code>SYSREF</code> is sampled. If you require <code>SYSREF</code> to be sampled again (due to link reset or reinitialization), you must set this bit again.  This register also has another critical function. The JESD204B IP never exits out of CGS unless at least a <code>SYSREF</code> edge is sampled. This is to prevent race condition between <code>SYSREF</code> being sampled and the exit of CGS to ILAS. If CGS transitions to ILAS before the common <code>SYSREF</code> is sampled for both the IP and converter device, this would cause undeterministic latency as the ILAS is transmitted based on the free running LMFC counter coming out of reset.	RW	0x1

continued...



Bit	Name	Description	Attribute	Reset
		<ul style="list-style-type: none"> <li>0 = Any rising edge of SYSREF will not reset the LMFC counter.</li> <li>1 = Resets the LMFC counter on the first rising edge of SYSREF and then clears this bit. (Default)</li> </ul> <p>Intel recommends to use <code>csr_sysref_singledet</code> with <code>csr_sysref_always on</code> even if you want to do SYSREF continuous detection mode. This is because this register is able to indicate whether SYSREF was ever sampled. This register also prevents race condition as mentioned above. Using only SYSREF single detect mode will not be able to detect incorrect SYSREF period.</p>		
1	<code>csr_sysref_always on</code>	<p>This register enables LMFC realignment at every rising edge of SYSREF. LMFC counter is reset when every SYSREF transition from 0 to 1 is detected.</p> <ul style="list-style-type: none"> <li>0 = Any rising edge of SYSREF will not reset the LMFC counter.</li> <li>1 = Continuously resets LMFC counter at every SYSREF rising edge.</li> </ul> <p>When this bit is set, the SYSREF period will be checked to make sure it never violates internal extended multiblock period and this period can only be n-integer multiplied of ((F<sub>x</sub>K)/4).</p> <p>If the SYSREF period is different from the local extended multiblock period, register <code>rx_err</code> (0x60) <code>csr_sysref_lmfc_err</code> will be asserted and an interrupt will be triggered.</p> <p>If you want to change SYSREF period, this bit should be set to 0 first. After SYSREF clock has stabilized, this bit is set to 1 to sample the rising edges of the new SYSREF.</p>	RW	0x0
0	<code>csr_link_reinit</code>	<p>The JESD204B IP will reinitialize the link to enter Code Group Synchronization by driving <code>SYNC_N</code> signal to 0. The software must check that <code>SYNC_N</code> (register <code>rx_status0</code> (0x80) <code>csr_dev_synch</code>) is 1 before setting this register. (This bit will be automatically cleared once link reinitialization is entered by hardware).</p> <ul style="list-style-type: none"> <li>0 = No link reinit request (Default)</li> <li>1 = Reinitialize the link.</li> </ul>	RW	0x0

**Table 69. `ctrl_reserve`**

Control register reserve.

Offset: 0x58

Bit	Name	Description	Attribute	Reset
31:0	Reserved	Reserved	RV	0x0



Table 70. rx\_err0

This register logs errors detected in the FPGA IP. Errors detected in the JESD204B IP will be logged in this register and `rx_err1` (0x64). Each set bit in the register will generate interrupt, if enabled by corresponding bits in the RX Error Enable (`rx_err_enable` (0x74)). After servicing the interrupt, the software must clear the appropriate serviced interrupt status bit and ensure that no other interrupts are pending. Each set bit in the register issues link reinitialization, if enabled by corresponding bits in the RX Error Link Reinitialization Enable (`rx_err_link_reinit` (0x78)). Only Code Group error cannot be disabled and must always force link reinitialization in order to comply to the JESD204B specification.

Offset: 0x60

Bit	Name	Description	Attribute	Reset
31:9	Reserved	Reserved	R	0x0
8	re4	RX error reserve status 4	RW1C	0x0
7	csr_pcfifo_empty_err	Detected 1 or more lanes of Phase Compensation FIFO is empty unexpectedly when the JESD204B link is running.  This status bit is not applicable for Intel Arria 10 devices with Soft PCS enabled and Intel Agilex and Intel Stratix 10 devices regardless of the PCS options.  <i>Note:</i> You MUST reset the JESD204B link if this bit is triggered. The transceiver channel, and the JESD204B IP link reset must be applied.	RW1C	0x0
6	csr_pcfifo_full_err	Detected 1 or more lanes of Phase Compensation FIFO is full unexpectedly when the JESD204B link is running.  Not applicable for Intel Agilex and Intel Stratix 10 devices.  <i>Note:</i> You MUST reset the JESD204B link if this bit is triggered. The transceiver channel, and the JESD204B IP link reset must be applied.	RW1C	0x0
5	csr_rx_locked_to_data_err	Detected 1 or more lanes of locked to data when the JESD204B link is running.	RW1C	0x0
4	csr_lane_deskew_err	Asserted when lane to lane deskew exceed the LMFC boundary. This error will trigger when <code>rx_bd_offset</code> is not correctly programmed or the lane to lane skew within the device or across multidevice has exceeded the LMFC boundary.  All ILA for all lanes should within one LMFC boundary. Refer to the application note on deterministic latency for more information.	RW1C	0x0
3	csr_frame_data_ready_err	This error bit will be asserted if the RX detects data ready by the upstream component is 0 on the AV-ST bus when data is valid. The transport layer expects the upstream device in the system (AV-ST sink component) will always be ready to receive the valid data from the transport layer.	RW1C	0x0

continued...



Bit	Name	Description	Attribute	Reset
		<i>Note:</i> If this error detection is not required, you can tie off the <code>jesd204_rx_data_ready</code> signal from the upstream to 1, in the Intel FPGA transport layer. This is the error from the transport layer instead from the JESD204B RX core.		
2	<code>csr_dll_data_ready_err</code>	This error bit will be asserted if the RX detects data ready by the upstream component is 0 on the AV-ST bus when data is valid. By design, the JESD204B RX core expects the upstream device (JESD204B transport layer) will always be ready to receive the valid data from the JESD204B RX core.  <i>Note:</i> If this error detection is not required, you can tie off the <code>jesd204_rx_link_ready</code> signal to 1.	RW1C	0x0
1	<code>csr_sysref_lmfc_err</code>	When register <code>syncn_sysref_ctrl</code> (0x54) <code>csr_sysref_always_on</code> is set to 1, the LMFC counter checks whether <code>SYSREF</code> period matches the LMFC counter where it is n-integer multiplier of the (F <sub>x</sub> K/4).  If <code>SYSREF</code> period does not match the LMFC period, this bit will be asserted.	RW1C	0x0
0	Reserved	Reserved	R	

**Table 71. rx\_err1**

This register logs errors detected in the FPGA IP. Errors detected in the JESD204B IP will be logged in this register and `rx_err1` (0x64). Each set bit in the register will generate interrupt, if enabled by corresponding bits in the RX Error Enable (`rx_err_enable` (0x74)). After servicing the interrupt, the software must clear the appropriate serviced interrupt status bit and ensure that no other interrupts are pending. Each set bit in the register issues link reinitialization, if enabled by corresponding bits in the RX Error Link Reinitialization Enable (`rx_err_link_reinit` (0x78)). Only Code Group error cannot be disabled and must always force link reinitialization in order to comply to the JESD204B specification..

Offset: 0x64

Bit	Name	Description	Attribute	Reset
31:10	Reserved	Reserved	R	0x0
9	<code>csr_ecc_fatal_err</code>	Assert when ECC fatal error occurs. This reflects a double bit error detected and uncorrected.	RW1C	0x0
8	<code>csr_ecc_corrected_err</code>	Assert when ECC error has been corrected. This reflects a single bit error detected and corrected.	RW1C	0x0
7	<code>dllerrs_rs</code>	DLL error reserve status.	RW1C	0x0
6	<code>csr_ilas_err</code>	Indicates that there is missing ILAS sequence. The RX core expects ILAS sequence to be transmitted after /K28.5/ transmission. When /K28.5/ transmission is not followed by ILAS, this error will be triggered.	RW1C	0x0

*continued...*



Bit	Name	Description	Attribute	Reset
		For devices NMCDA-SL where there is an option to disable transmission of ILAS, you need to mask out this error using error mask.		
5	csr_disparity_err	Running disparity error for all lanes, the received code group exists in the 8b10b decoding table, but is not found in the proper column according to the current running disparity.	RW1C	0x0
4	csr_not_in_table_err	Not in table error for all lanes, the received code group is not found in the 8b10b decoding table for either disparity.	RW1C	0x0
3	csr_unexpected_kchar	Unexpected control character error for all lanes, a control character is received that is not expected at the given character position. Unexpected /A/ or /F/ character will be flagged as frame alignment error or lane alignment error.	RW1C	0x0
2	csr_lane_alignment_err	Lane alignment error for all lanes, the previous conversion samples may be in error. End-of-multiframe marker (/A/) position has misaligned. Dynamic realignment is not supported.	RW1C	0x0
1	csr_frame_alignment_err	Frame alignment error for all lanes, the previous conversion samples may be in error. End-of-frame marker (/F/ or /A/) position has misaligned. Dynamic realignment is not supported.	RW1C	0x0
0	csr_cg_sync_err	Code group synchronization error for all lanes, indicates that the state machine has returned to the CS_INIT state.	RW1C	0x0

**Table 72. rx\_err\_enable**

This register enables the error types that will generate interrupt. Setting 0 to the register bits will disable the specific error type from generating interrupt.

Offset: 0x74

Bit	Name	Description	Attribute	Reset
31:21	Reserved	Reserved	R	0x0
20	csr_ecc_fatal_err_en	Enable interrupt for ECC fatal error type. Applicable to all lanes.	RW	0x1
19	csr_ecc_corrected_err_en	Enable interrupt for ECC correctable error type. Applicable to all lanes.	RW	0x0
18	dllerr_rs_en	DLL error 1 enable reserve. Applicable to all lanes.	RW	0x1
17	csr_ilas_err_en	Enable interrupt for missing ILAS error type. Applicable to all lanes.	RW	0x1
16	csr_disparity_err_en	Enable interrupt for disparity error type. Applicable to all lanes.	RW	0x1

**continued...**



Bit	Name	Description	Attribute	Reset
15	csr_not_in_table_err_en	Enable interrupt for not in table error type. Applicable to all lanes.	RW	0x1
14	csr_unexpected_kchar_en	Enable interrupt for unexpected control character type. Applicable to all lanes.	RW	0x1
13	csr_lane_alignment_err_en	Enable interrupt for lane alignment error type. Applicable to all lanes.	RV	0x1
12	csr_frame_alignment_err_en	Enable interrupt for frame alignment error type. Applicable to all lanes.	RV	0x1
11	csr_cg_sync_err_en	Enable interrupt for code group synchronization error type. Applicable to all lanes.	RW	0x1
10:9	Reserved	Reserved	R	0x0
8	re4_en	RX error enable reserve 4	RW	0x1
7	csr_pcfifo_empty_err_en	Enable interrupt for Phase Compensation FIFO empty error.	RW	0x1
6	csr_pcfifo_full_err_en	Enable interrupt for Phase Compensation FIFO full error.	RW	0x1
5	csr_rx_locked_to_data_err_en	Enable interrupt for RX is not locked to data error.	RW	0x1
4	csr_lane_deskew_err_en	Enable interrupt for lane deskew error type.	RW	0x1
3	csr_frame_data_ready_err_en	Enable interrupt for transport layer data ready error type.	RW	0x1
2	csr_dll_data_ready_err_en	Enable interrupt for DLL data ready error type.	RW	0x1
1	csr_sysref_lmfc_err_en	Enable interrupt for SYSREF LMFC error type.	RW	0x1
0	Reserved	Reserved	R	0x0

**Table 73. rx\_err\_link\_reinit**

This register enables the error types that will generate link reinit. Link reinitialization is entered by the FPGA IP by asserting `SYNC_N` low. Setting 0 to the register bits will disable the specific error type from link reinitialization. Code group synchronization error does not have an enabled bit because the JESD204B specification requires code group error to deassert `SYNC_N` and request for link reinitialization.

0: Do not reinitialize even if the particular error type is triggered. (Default)

1: Reinitialize if the particular error type is triggered.

Offset: 0x78

Bit	Name	Description	Attribute	Reset
31:21	Reserved	Reserved	R	0x0
20	csr_ecc_err_fatal_link_reinit	Enable link reinitialization for ECC fatal error type. Applicable to all lanes. User is not recommended to reinit since ECC error is not due to link issue.	RW	0x0
19	csr_ecc_err_corrected_link_reinit	Enable link reinitialization for ECC correctable error type. Applicable to all lanes. User is not recommended to reinit since ECC error is self-recovered.	RW	0x0

*continued...*





Bit	Name	Description	Attribute	Reset
18	csr_dllerr_rs_link_reinit	DLL error 1 link reinit enable reserve. Applicable to all lanes.	RW	0x0
17	csr_ilas_err_link_reinit	Enable link reinitialization for missing ILAS error type. Applicable to all lanes.	RW	0x0
16	csr_disparity_err_link_reinit	Enable link reinitialization for disparity error type. Applicable to all lanes.	RW	0x0
15	csr_not_in_table_err_link_reinit	Enable link reinitialization for not in table error type. Applicable to all lanes.	RW	0x0
14	csr_unexpected_kchar_link_reinit	Enable link reinitialization for unexpected control character error type. Applicable to all lanes.	RW	0x0
13	csr_lane_alignment_err_link_reinit	Enable link reinitialization for lane alignment error type. Applicable to all lanes.	RW	0x0
12	csr_frame_alignment_err_link_reinit	Enable link re-initialization for frame alignment error type. Applicable to all lanes.	RW	0x0
11	rs5_link_reinit	RX error link reinit enable reserve 4	RW	0x1
10:9	Reserved	Reserved	R	0x0
8	rs4_link_reinit	RX error link reinit enable reserve 4	RW	0x1
7	csr_pcfifo_empty_err_link_reinit	Enable link reinitialization for Phase Compensation FIFO empty error.	RW	0x0
6	csr_pcfifo_full_err_link_reinit	Enable link reinitialization for Phase Compensation FIFO full error.	RW	0x0
5	csr_rx_locked_to_data_err_link_reinit	Enable link reinitialization for RX is not locked to data error.	RW	0x0
4	csr_lane_deskew_err_link_reinit	Enable link reinitialization for lane deskew error type.	RW	0x0
3	csr_frame_data_ready_err_link_reinit	Enable link reinitialization for Transport Layer data ready error type.	RW	0x0
2	csr_dll_data_ready_err_link_reinit	Enable link reinitialization for DLL data ready error type.	RW	0x0
1	csr_sysref_lmfc_err_link_reinit	Enable link reinitialization for SYSREF LMFC error type.	RW	0x1
0	Reserved	Reserved	R	0x0

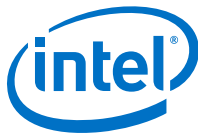
**Table 74. rx\_status0**

Monitor ports of internal signals and counter which will be useful for debug.

Offset: 0x80

Bit	Name	Description	Attribute	Reset
31:19	Reserved	Reserved	R	0x0
18	RX Status reserve 8	Reserved	R	0x0

*continued...*



Bit	Name	Description	Attribute	Reset
17	RX Status reserve 7	Reserved	R	0x0
16	RX Status reserve 6	Reserved	R	0x0
15	RX Status reserve 5	Reserved	R	0x0
14	RX Status reserve 4	Reserved	R	0x0
13	RX Status reserve 3	Reserved	R	0x0
12	RX Status reserve 2	Reserved	R	0x0
11	RX Status reserve 1	Reserved	R	0x0
10:3	csr_rbd_count	<p>This is a binary minus 1 value. Legal value reported from this register is ((F<sub>x</sub>K/4)-1) to 0.</p> <ul style="list-style-type: none"> <li>When <code>csr_rbd_count = 0</code>, this indicates that the latest lane arrives within the link at the LMFC boundary.</li> <li>When <code>csr_rbd_count = 1</code>, this indicates that the latest lane arrives within the link at 1 link clock cycle before the LMFC boundary.</li> </ul> <p><i>Note:</i> When the latest lane arrival in the link is too close to the LMFC boundary, Intel recommends to set the RBD release opportunity (<code>sysref_ctrl 0x54 rbd_offset</code>) at least 2 link clocks away from the <code>csr_rbd_count</code> register to accommodate for worst-case power cycle variation.</p>	R	0x0
2:1	Reserved	Reserved	R	0x0
0	csr_dev_syncn	<p>Internal SYNC_N value.</p> <ul style="list-style-type: none"> <li>0 = Receiver is asserting synchronization request.</li> <li>1 = JESD204B link is out of synchronization</li> </ul>	R	0x0

**Table 75. rx\_status1**

Monitor ports of internal signals and counter which will be useful for debug.

Offset: 0x84

Bit	Name	Description	Attribute	Reset
31:24	Reserved	Reserved	R	0x0
23	csr_lane7_rx_pcfifo_empty	RX phase compensation fifo status empty flag for lane 7.	R	0x0

*continued...*



Bit	Name	Description	Attribute	Reset
22	csr_lane6_rx_pcfifo_empty	RX phase compensation fifo status empty flag for lane 6.	R	0x0
21	csr_lane5_rx_pcfifo_empty	RX phase compensation fifo status empty flag for lane 5.	R	0x0
20	csr_lane4_rx_pcfifo_empty	RX phase compensation fifo status empty flag for lane 4.	R	0x0
19	csr_lane3_rx_pcfifo_empty	RX phase compensation fifo status empty flag for lane 3.	R	0x0
18	csr_lane2_rx_pcfifo_empty	RX phase compensation fifo status empty flag for lane 2.	R	0x0
17	csr_lane1_rx_pcfifo_empty	RX phase compensation fifo status empty flag for lane 1.	R	0x0
16	csr_lane0_rx_pcfifo_empty	RX phase compensation fifo status empty flag for lane 0.	R	0x0
15:8	Reserved	Reserved	R	0x0
7	csr_lane7_rx_pcfifo_full	RX phase compensation fifo status full flag for lane 7.	R	0x0
6	csr_lane6_rx_pcfifo_full	RX phase compensation fifo status full flag for lane 6.	R	0x0
5	csr_lane5_rx_pcfifo_full	RX phase compensation fifo status full flag for lane 5.	R	0x0
4	csr_lane4_rx_pcfifo_full	RX phase compensation fifo status full flag for lane 4.	R	0x0
3	csr_lane3_rx_pcfifo_full	RX phase compensation fifo status full flag for lane 3.	R	0x0
2	csr_lane2_rx_pcfifo_full	RX phase compensation fifo status full flag for lane 2.	R	0x0
1	csr_lane1_rx_pcfifo_full	RX phase compensation fifo status full flag for lane 1.	R	0x0
0	csr_lane0_rx_pcfifo_full	RX phase compensation fifo status full flag for lane 0.	R	0x0

**Table 76. rx\_status2**

Monitor ports of internal signals and counter which will be useful for debug.

Offset: 0x88

Bit	Name	Description	Attribute	Reset
31:24	Reserved	Reserved	R	0x0
23	csr_lane7_pcs_valid	PCS status for lane 7, indicates PCS is valid, the correct word boundary has been found and aligned to it.	R	0x0
22	csr_lane6_pcs_valid	PCS status for lane 6, indicates PCS is valid, the correct word boundary has been found and aligned to it.	R	0x0
21	csr_lane5_pcs_valid	PCS status for lane 5, indicates PCS is valid, the correct word boundary has been found and aligned to it.	R	0x0

*continued...*



Bit	Name	Description	Attribute	Reset
20	csr_lane4_pcs_val_id	PCS status for lane 4, indicates PCS is valid, the correct word boundary has been found and aligned to it.	R	0x0
19	csr_lane3_pcs_val_id	PCS status for lane 3, indicates PCS is valid, the correct word boundary has been found and aligned to it.	R	0x0
18	csr_lane2_pcs_val_id	PCS status for lane 2, indicates PCS is valid, the correct word boundary has been found and aligned to it.	R	0x0
17	csr_lane1_pcs_val_id	PCS status for lane 1, indicates PCS is valid, the correct word boundary has been found and aligned to it.	R	0x0
16	csr_lane0_pcs_val_id	PCS status for lane 0, indicates PCS is valid, the correct word boundary has been found and aligned to it.	R	0x0
15:8	Reserved	Reserved	R	0x0
7	csr_lane7_rx_cal_busy	Reconfig status for lane 7, indicates RX calibration is in progress.	R	0x0
6	csr_lane6_rx_cal_busy	Reconfig status for lane 6, indicates RX calibration is in progress.	R	0x0
5	csr_lane5_rx_cal_busy	Reconfig status for lane 5, indicates RX calibration is in progress.	R	0x0
4	csr_lane4_rx_cal_busy	Reconfig status for lane 4, indicates RX calibration is in progress.	R	0x0
3	csr_lane3_rx_cal_busy	Reconfig status for lane 3, indicates RX calibration is in progress.	R	0x0
2	csr_lane2_rx_cal_busy	Reconfig status for lane 2, indicates RX calibration is in progress.	R	0x0
1	csr_lane1_rx_cal_busy	Reconfig status for lane 1, indicates RX calibration is in progress.	R	0x0
0	csr_lane0_rx_cal_busy	Reconfig status for lane 0, indicates RX calibration is in progress.	R	0x0

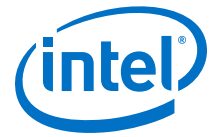
**Table 77. rx\_status3**

Monitor ports of internal signals and counter which will be useful for debug.

Offset: 0x8C

Bit	Name	Description	Attribute	Reset
31:8	Reserved	Reserved	R	0x0
7	csr_lane7_rx_locked_to_data	When asserted, indicates that the RX CDR PLL for lane 7 is locked to the RX data and that the RX CDR has changed from LTR to LTD mode.	R	0x0
6	csr_lane6_rx_locked_to_data	When asserted, indicates that the RX CDR PLL for lane 6 is locked to the RX data and that the RX CDR has changed from LTR to LTD mode.	R	0x0

*continued...*



Bit	Name	Description	Attribute	Reset
5	csr_lane5_rx_locked_to_data	When asserted, indicates that the RX CDR PLL for lane 5 is locked to the RX data and that the RX CDR has changed from LTR to LTD mode.	R	0x0
4	csr_lane4_rx_locked_to_data	When asserted, indicates that the RX CDR PLL for lane 4 is locked to the RX data and that the RX CDR has changed from LTR to LTD mode.	R	0x0
3	csr_lane3_rx_locked_to_data	When asserted, indicates that the RX CDR PLL for lane 3 is locked to the RX data and that the RX CDR has changed from LTR to LTD mode.	R	0x0
2	csr_lane2_rx_locked_to_data	When asserted, indicates that the RX CDR PLL for lane 2 is locked to the RX data and that the RX CDR has changed from LTR to LTD mode.	R	0x0
1	csr_lane1_rx_locked_to_data	When asserted, indicates that the RX CDR PLL for lane 1 is locked to the RX data and that the RX CDR has changed from LTR to LTD mode.	R	0x0
0	csr_lane0_rx_locked_to_data	When asserted, indicates that the RX CDR PLL for lane 0 is locked to the RX data and that the RX CDR has changed from LTR to LTD mode.	R	0x0

**Table 78. ilas\_data1**

Link control configuration transmitted during initial lane alignment sequence (ILAS).

Offset: 0x94

Bit	Name	Description	Attribute	Reset
31:24	csr_m	Link M. Number of converters per device (binary value minus 1). <i>Note:</i> Run-time reconfiguration is disabled for Intel Agilex and Intel Stratix 10 devices.	<ul style="list-style-type: none"> <li>RW for all devices except Intel Agilex and Intel Stratix 10</li> <li>RO for Intel Agilex and Intel Stratix 10 devices</li> </ul>	Reset to parameter value per IP generation.
23:21	Reserved	Reserved	R	0x0
20:16	csr_k	Link K. Number of frames per multiframe (binary value minus 1). <i>Note:</i> Run-time reconfiguration is disabled for Intel Agilex and Intel Stratix 10 devices.	<ul style="list-style-type: none"> <li>RW for all devices except Intel Agilex and Intel Stratix 10</li> <li>RO for Intel Agilex and Intel Stratix 10 devices</li> </ul>	Reset to parameter value per IP generation.

*continued...*



Bit	Name	Description	Attribute	Reset
15:8	csr_f	Link F. Number of octets per frame (binary value minus 1). <i>Note:</i> Run-time reconfiguration is disabled for Intel Agilex and Intel Stratix 10 devices.	<ul style="list-style-type: none"> <li>RW for all devices except Intel Agilex and Intel Stratix 10</li> <li>RO for Intel Agilex and Intel Stratix 10 devices</li> </ul>	Reset to parameter value per IP generation.
7	csr_scr_en	Enable or disable descrambler. <ul style="list-style-type: none"> <li>0 = Disable descrambler</li> <li>1 = Enable descrambler</li> </ul> <i>Note:</i> Run-time reconfiguration is disabled for Intel Agilex and Intel Stratix 10 devices.	<ul style="list-style-type: none"> <li>RW for all devices except Intel Agilex and Intel Stratix 10</li> <li>RO for Intel Agilex and Intel Stratix 10 devices</li> </ul>	Reset to parameter value per IP generation.
6:5	Reserved	Reserved	R	0x0
4:0	csr_l	Link L. Number of lanes per converter (binary value minus 1). <i>Note:</i> Run-time reconfiguration is disabled for Intel Agilex and Intel Stratix 10 devices.	<ul style="list-style-type: none"> <li>RW for all devices except Intel Agilex and Intel Stratix 10</li> <li>RO for Intel Agilex and Intel Stratix 10 devices</li> </ul>	Reset to parameter value per IP generation.

**Table 79. ilas\_data2**

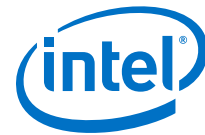
Link control configuration transmitted during initial lane alignment sequence (ILAS).

Offset: 0x98

Bit	Name	Description	Attribute	Reset
31	csr_hd	Link HD. High density format. <i>Note:</i> Run-time reconfiguration is disabled for Intel Agilex and Intel Stratix 10 devices.	<ul style="list-style-type: none"> <li>RW for all devices except Intel Agilex and Intel Stratix 10</li> <li>RO for Intel Agilex and Intel Stratix 10 devices</li> </ul>	Reset to parameter value per IP generation.
30:29	Reserved	Reserved	R	0x0
28:24	csr_cf	Link CF. Number of control words per frame clock period per link <ul style="list-style-type: none"> <li>CF = L is encoded as 31: control words on all lanes.</li> <li>CF = 31 can only occur when L = 31</li> </ul> <i>Note:</i> Run-time reconfiguration is disabled for Intel Agilex and Intel Stratix 10 devices.	<ul style="list-style-type: none"> <li>RW for all devices except Intel Agilex and Intel Stratix 10</li> <li>RO for Intel Agilex and Intel Stratix 10 devices</li> </ul>	Reset to parameter value per IP generation.
<i>continued...</i>				

#### 4. JESD204B IP Functional Description

UG-01142 | 2020.03.03



Bit	Name	Description	Attribute	Reset
23:21	csr_jesdv	JESD204x version. <ul style="list-style-type: none"> <li>• 000 = JESD204A</li> <li>• 001 = JESD204B</li> </ul> <i>Note:</i> Run-time reconfiguration is disabled for Intel Agilex and Intel Stratix 10 devices.	<ul style="list-style-type: none"> <li>• RW for all devices except Intel Agilex and Intel Stratix 10</li> <li>• RO for Intel Agilex and Intel Stratix 10 devices</li> </ul>	0x1
20:16	csr_s	Link S. Number of samples per converter per frame cycle (binary value minus 1). <i>Note:</i> Run-time reconfiguration is disabled for Intel Agilex and Intel Stratix 10 devices.	<ul style="list-style-type: none"> <li>• RW for all devices except Intel Agilex and Intel Stratix 10</li> <li>• RO for Intel Agilex and Intel Stratix 10 devices</li> </ul>	Reset to parameter value per IP generation.
15:13	csr_subclassv	Device subclass version <ul style="list-style-type: none"> <li>• 000 = Subclass 0</li> <li>• 001 = Subclass 1</li> <li>• 010 = Subclass 2</li> </ul> <i>Note:</i> Run-time reconfiguration is disabled for Intel Agilex and Intel Stratix 10 devices.	<ul style="list-style-type: none"> <li>• RW for all devices except Intel Agilex and Intel Stratix 10</li> <li>• RO for Intel Agilex and Intel Stratix 10 devices</li> </ul>	Reset to parameter value per IP generation.
12:8	csr_np	Link NP. Total number of bits per sample (binary value minus 1). <i>Note:</i> Run-time reconfiguration is disabled for Intel Agilex and Intel Stratix 10 devices.	<ul style="list-style-type: none"> <li>• RW for all devices except Intel Agilex and Intel Stratix 10</li> <li>• RO for Intel Agilex and Intel Stratix 10 devices</li> </ul>	Reset to parameter value per IP generation.
7:6	csr_cs	Link CS. Number of control bits per sample. <i>Note:</i> Run-time reconfiguration is disabled for Intel Agilex and Intel Stratix 10 devices.	<ul style="list-style-type: none"> <li>• RW for all devices except Intel Agilex and Intel Stratix 10</li> <li>• RO for Intel Agilex and Intel Stratix 10 devices</li> </ul>	Reset to parameter value per IP generation.
5	Reserved	Reserved	R	0x0
4:0	csr_n	Link N. Converter resolution (binary value minus 1). <i>Note:</i> Run-time reconfiguration is disabled for Intel Agilex and Intel Stratix 10 devices.	<ul style="list-style-type: none"> <li>• RW for all devices except Intel Agilex and Intel Stratix 10</li> <li>• RO for Intel Agilex and Intel Stratix 10 devices</li> </ul>	Reset to parameter value per IP generation.

**Table 80. ilas\_octet0**

Link control configuration fields in octets for configuration checking. All of the ILAS configuration data from the converter device is latched and can be accessed through `ilas_octet0` (0xA0), `ilas_octet1` (0xA4), `ilas_octet2` (0xA8), and `ilas_octet3` (0xAC). To access configuration data transmitted for each individual channel, configure the `csr_ilas_data_sel` register correctly to multiplex the ILAS configuration data from different channels to these registers.

Offset: 0xA0

Bit	Name	Description	Attribute	Reset
31:24	no3	Configuration octet 3: SCR, L	R	0x00
23:16	no2	Configuration octet 2: ADJDIR, PHADJ, LID	R	0x00
15:8	no1	Configuration octet 1: ADJCNT, BID	R	0x00
7:0	no0	Configuration octet 0: DID	R	0x00

**Table 81. ilas\_octet1**

Link control configuration fields in octets for configuration checking.

Offset: 0xA4

Bit	Name	Description	Attribute	Reset
31:24	no7	Configuration octet 7: CS, N	R	0x00
23:16	no6	Configuration octet 6: M	R	0x00
15:8	no5	Configuration octet 5: K	R	0x00
7:0	no4	Configuration octet 4: F	R	0x00

**Table 82. ilas\_octet2**

Link control configuration fields in octets for configuration checking.

Offset: 0xA8

Bit	Name	Description	Attribute	Reset
31:24	no11	Configuration octet 11: RES1	R	0x00
23:16	no10	Configuration octet 10: HD, CF	R	0x00
15:8	no9	Configuration octet 9: JESDV, S	R	0x00
7:0	no8	Configuration octet 8: SUBCLASSV, N_PRIME	R	0x00

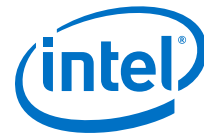
**Table 83. ilas\_octet3**

Link control configuration fields in octets for configuration checking.

Offset: 0xAC

Bit	Name	Description	Attribute	Reset
31:16	Reserved	Reserved	R	0x00
15:8	no13	Configuration octet 13: FCHK	R	0x00
7:0	no12	Configuration octet 12: RES2	R	0x00



**Table 84. ilas\_data12**

Link control configuration transmitted during initial lane alignment sequence (ILAS).

Offset: 0xC0

Bit	Name	Description	Attribute	Reset
31:10	Reserved	Reserved	R	0x0
9:2	csr_fxk_h	Upper bits of FxK[1:0]. This is a binary value minus 1. Link F multiply with Link K must be divisible by 4. <i>Note:</i> The IP runs on 32-bit data width boundary per channel, so you must always ensure that FxK must be divisible by 4. <i>Note:</i> Run-time reconfiguration is disabled for Intel Agilex and Intel Stratix 10 devices.	<ul style="list-style-type: none"> <li>RW for all devices except Intel Agilex and Intel Stratix 10</li> <li>RO for Intel Agilex and Intel Stratix 10 devices</li> </ul>	Reset to parameter value per IP generation
1:0	csr_fxk_l	Lower bits of FxK[1:0]. This is a binary value minus 1. Link F multiply with Link K must be divisible by 4. <i>Note:</i> The IP runs on 32-bit data width boundary per channel, so you must always ensure that FxK must be divisible by 4. FxK (in binary value minus 1) will always result in the lower 2 bits value to be 2'b11.	R	0x3

**Table 85. rx\_test**

JESD204 RX test control.

Offset: 0xD0

Bit	Name	Description	Attribute	Reset
31:4	Reserved	Reserved	R	0x0
3:0	rx_testmode	<ul style="list-style-type: none"> <li>'b0xxx is reserved for the JESD204B IP</li> <li>'b1xxx is reserved for external components outside of the JESD204B IP</li> </ul> JESD204B IP test mode. <ul style="list-style-type: none"> <li>0000 = No test (Default)</li> <li>0001 = K28.5</li> <li>0010 = D21.5</li> </ul> JESD204B IP reference design test Mode : <ul style="list-style-type: none"> <li>1000 = Alternating checkerboard</li> <li>1001 = Ramp</li> <li>1010 = PRBS</li> </ul>	RW	0x0



**Table 86. rx\_status4**

Monitor ports of internal signals and counter which will be useful for debug.

Offset: 0xF0

Bit	Name	Description	Attribute	Reset
31:16	Reserved	Reserved	R	0x0
15:14	lane7_cs_state	Indicates current state of RX DLL code group synchronization state machine for lane 7.	R	0x0
13:12	lane6_cs_state	Indicates current state of RX DLL code group synchronization state machine for lane 6.	R	0x0
11:10	lane5_cs_state	Indicates current state of RX DLL code group synchronization state machine for lane 5.	R	0x0
9:8	lane4_cs_state	Indicates current state of RX DLL code group synchronization state machine for lane 4.	R	0x0
7:6	lane3_cs_state	Indicates current state of RX DLL code group synchronization state machine for lane 3.	R	0x0
5:4	lane2_cs_state	Indicates current state of RX DLL code group synchronization state machine for lane 2.	R	0x0
3:2	lane1_cs_state	Indicates current state of RX DLL code group synchronization state machine for lane 1.	R	0x0
1:0	lane0_cs_state	Indicates current state of RX DLL code group synchronization state machine for lane 0.	R	0x0

**Table 87. rx\_status5**

Monitor ports of internal signals and counter which will be useful for debug.

Offset: 0xF4

Bit	Name	Description	Attribute	Reset
31:16	Reserved	Reserved	R	0x0
15:14	lane7_fs_state	Indicates current state of RX DLL frame synchronization state machine for lane 7.	R	0x0
13:12	lane6_fs_state	Indicates current state of RX DLL frame synchronization state machine for lane 6.	R	0x0
11:10	lane5_fs_state	Indicates current state of RX DLL frame synchronization state machine for lane 5.	R	0x0
9:8	lane4_fs_state	Indicates current state of RX DLL frame synchronization state machine for lane 4.	R	0x0
7:6	lane3_fs_state	Indicates current state of RX DLL frame synchronization state machine for lane 3.	R	0x0
<i>continued...</i>				



Bit	Name	Description	Attribute	Reset
5:4	lane2_fs_state	Indicates current state of RX DLL frame synchronization state machine for lane 2.	R	0x0
3:2	lane1_fs_state	Indicates current state of RX DLL frame synchronization state machine for lane 1.	R	0x0
1:0	lane0_fs_state	Indicates current state of RX DLL frame synchronization state machine for lane 0.	R	0x0

**Table 88. rx\_status6**

Monitor ports of internal signals and counter which will be useful for debug.

Offset: 0xF8

Bit	Name	Description	Attribute	Reset
31:24	Reserved	Reserved	R	0x0
23	lane7_rx_fifo_empty	Indicates that RX DLL FIFO is empty for lane 7.	R	0x0
22	lane6_rx_fifo_empty	Indicates that RX DLL FIFO is empty for lane 6.	R	0x0
21	lane5_rx_fifo_empty	Indicates that RX DLL FIFO is empty for lane 5.	R	0x0
20	lane4_rx_fifo_empty	Indicates that RX DLL FIFO is empty for lane 4.	R	0x0
19	lane3_rx_fifo_empty	Indicates that RX DLL FIFO is empty for lane 3.	R	0x0
18	lane2_rx_fifo_empty	Indicates that RX DLL FIFO is empty for lane 2.	R	0x0
17	lane1_rx_fifo_empty	Indicates that RX DLL FIFO is empty for lane 1.	R	0x0
16	lane0_rx_fifo_empty	Indicates that RX DLL FIFO is empty for lane 0.	R	0x0
15:8	Reserved	Reserved	R	0x0
7	lane7_rx_fifo_full	Indicates that RX DLL lane sync FIFO is full for lane 7.	R	0x0
6	lane6_rx_fifo_full	Indicates that RX DLL lane sync FIFO is full for lane 6.	R	0x0
5	lane5_rx_fifo_full	Indicates that RX DLL lane sync FIFO is full for lane 5.	R	0x0
4	lane4_rx_fifo_full	Indicates that RX DLL lane sync FIFO is full for lane 4.	R	0x0
3	lane3_rx_fifo_full	Indicates that RX DLL lane sync FIFO is full for lane 3.	R	0x0

*continued...*



Bit	Name	Description	Attribute	Reset
2	lane2_rx_fifo_full	Indicates that RX DLL lane sync FIFO is full for lane 2.	R	0x0
1	lane1_rx_fifo_full	Indicates that RX DLL lane sync FIFO is full for lane 1.	R	0x0
0	lane0_rx_fifo_full	Indicates that RX DLL lane sync FIFO is full for lane 0.	R	0x0

**Table 89. rx\_status7**

Monitor ports of internal signals and counter which will be useful for debug.

Offset: 0xFC

Bit	Name	Description	Attribute	Reset
31:24	Reserved	Reserved	R	0x0
23	lane7_ilas_cfg_data_started	ILAS CFG data started for lane 7.	R	0x0
22	lane6_ilas_cfg_data_started	ILAS CFG data started for lane 6.	R	0x0
21	lane5_ilas_cfg_data_started	ILAS CFG data started for lane 5.	R	0x0
20	lane4_ilas_cfg_data_started4	ILAS CFG data started for lane 4.	R	0x0
19	lane3_ilas_cfg_data_started	ILAS CFG data started for lane 3.	R	0x0
18	lane2_ilas_cfg_data_started	ILAS CFG data started for lane 2.	R	0x0
17	lane1_ilas_cfg_data_started	ILAS CFG data started for lane 1.	R	0x0
16	lane0_ilas_cfg_data_started	ILAS CFG data started for lane 0.	R	0x0
15:8	Reserved	Reserved	R	0x0
7	lane7_dll_user_data_phase	DLL user data phase for lane 7.	R	0x0
6	lane6_dll_user_data_phase	DLL user data phase for lane 6.	R	0x0
5	lane5_dll_user_data_phase	DLL user data phase for lane 5.	R	0x0
4	lane4_dll_user_data_phase	DLL user data phase for lane 4.	R	0x0
3	lane3_dll_user_data_phase	DLL user data phase for lane 3.	R	0x0
2	lane2_dll_user_data_phase	DLL user data phase for lane 2.	R	0x0
1	lane1_dll_user_data_phase	DLL user data phase for lane 1.	R	0x0
0	lane0_dll_user_data_phase	DLL user data phase for lane 0.	R	0x0

## 5. JESD204B IP Deterministic Latency Implementation Guidelines

---

Subclass 1 and Subclass 2 modes support deterministic latency. This section describes the features available in the JESD204B IP that you can use to achieve Subclass 1 deterministic latency in your design. This section also covers some best practices for Subclass 1 implementation like constraining the incoming *SYSREF* signal and maintaining deterministic latency during link reinitialization.

Features available:

- Programmable RBD offset.
- Programmable LMFC offset.

### 5.1. Constraining Incoming *SYSREF* Signal

The *SYSREF* signal resets the LMFC counter in the IP for subclass 1 implementation. Constraining the *SYSREF* signal ensures that the setup relationship between *SYSREF* and device clock is established.

The setup time is analyzed when you set the timing constraint for the *SYSREF* signal in the user *.sdc* file. When the setup time is met, the *SYSREF* signal detection by the IP is deterministic; the number of link clock cycles of *SYSREF* signal that arrives at the FPGA pin to the LMFC counter resets, is deterministic.

Apply the *set\_input\_delay* constraint on the *SYSREF* signal with respect to device clock in the user *.sdc* file:

```
set_input_delay -clock <device clock name at FPGA pin> <sysref IO delay in ns> [get_ports <sysref name at FPGA pin >]
```

The *SYSREF* IO delay is the board trace length mismatch between device clock and *SYSREF*. For example:

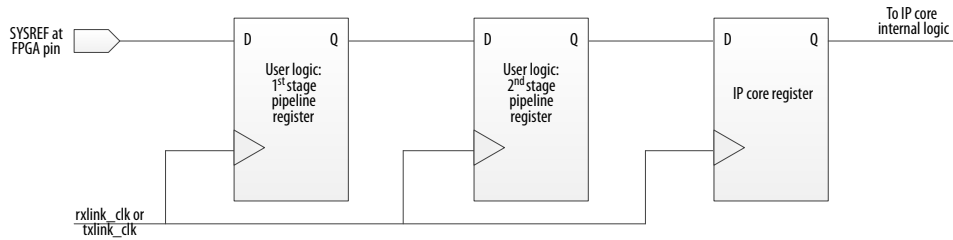
```
set_input_delay -clock device_clk 0.5 [get_ports sysref]
```

The above statement constrains the FPGA *SYSREF* signal (*sysref*), with respect to the FPGA device clock (*device\_clk*) pin. The trace length mismatch resulted in 500 ps or 0.5 ns difference in time arrival at the FPGA pins between *SYSREF* and device clock.

In most cases, the register in the IP, which detects the *SYSREF* signal, is far away from the *SYSREF* I/O pin. The long interconnect routing delay results in timing violation. You are recommended to use multi-stages pipeline registers to close timing. Use the same clock domain as the JESD204B IP's *rxlink\_clk* and *txlink\_clk* to clock the multi-stages pipeline registers.

**Figure 25. Multi-Stage Pipeline Register for SYSREF Signal**

Figure shows a two stages pipeline registers for the SYSREF signal.



## 5.2. Programmable RBD Offset

In the RX IP core, the programmable RBD offset provides flexibility for an early RBD release to optimize the latency through the IP core. You can configure the RBD offset using the `csr_rbd_offset` field in the `syncn_sysref_ctrl` register.

You must set a safe RBD offset value to ensure deterministic latency from one power cycle to another power cycle. Follow these steps to set a safe RBD offset value:

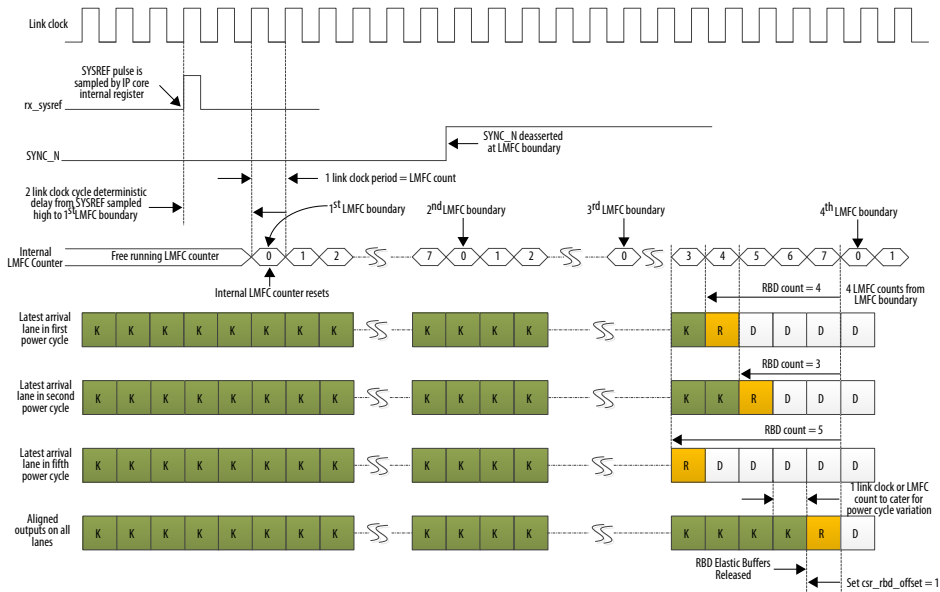
1. Read the RBD count from the `csr_rbd_count` field in `rx_status0` register. Record the value.
2. Power cycle the JESD204B subsystem, which consists of the FPGA and converter devices.
3. Read the RBD count again and record the value.
4. Repeat steps 1 to 3 at least 5 times and record the RBD count values.
5. Set the `csr_rbd_offset` accordingly with one LMFC count tolerance.
6. Perform multiple power cycles and make sure lane deskew error does not occur using this RBD offset value.

The RBD count must be fairly consistent, within 2 counts variation from one power cycle to another power cycle. In the following examples, the parameter values are  $L > 1$ ,  $F=1$  and  $K=32$ . The legal values of the LMFC counter is 0 to  $((FxK/4)-1)$ , which is 0 to 7. In [Figure 26](#) on page 151, the latest arrival lane variation falls within 1 local multiframe period. In this scenario, if latency is not a concern, you can leave the default value of `csr_rbd_offset=0`, which means the RBD elastic buffer is released at the LMFC boundary. In [Figure 27](#) on page 152, the latest arrival lane variation spans across 2 local multiframes; the latest arrival lane variation happens before and after the LMFC boundary. In this scenario, you need to configure the RBD offset correctly to avoid lane deskew error as indicated in bit 4 of `rx_err0` register.



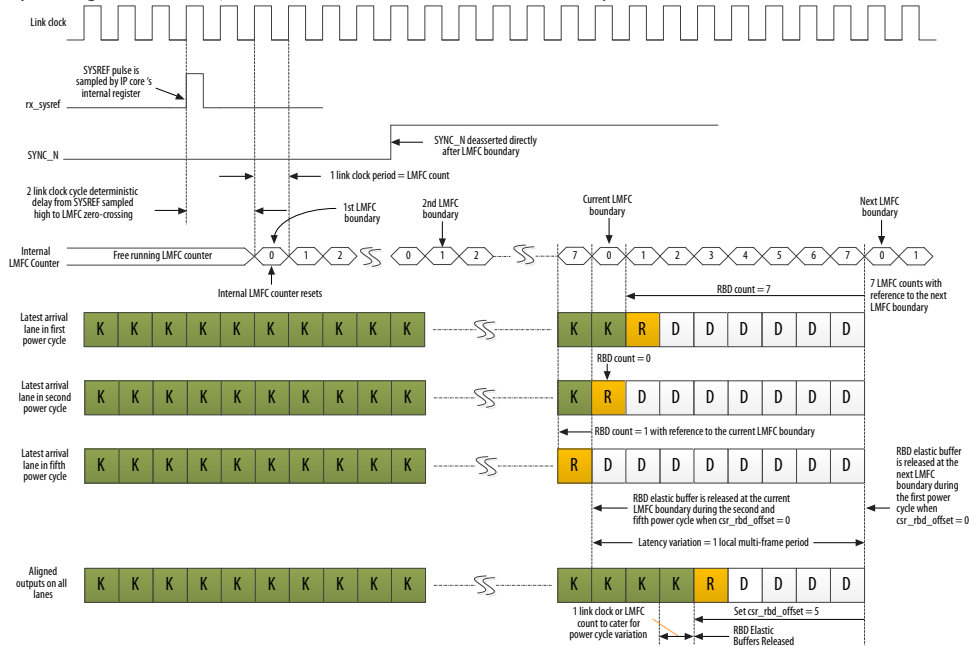
**Figure 26. Early RBD Release Opportunity for Latest Arrival Lane Within One Local Multi Frame Scenario**

In this example, the SYSREF pulse at *rx\_sysref* port of the IP core is sampled by the internal register. After 2 link clock cycles, the LMFC counter resets. The delay from SYSREF sampled high to LMFC counter resets is deterministic. The transition of /K/ character to /R/ character marks the beginning of ILAS phase. The number of LMFC count of the /R/ character relative to the next LMFC boundary in the latest arrival lane is reported as the RBD count. In the first power cycle, the /R/ character is received at 4 LMFC counts before the next LMFC boundary, hence the RBD count = 4. In the second power cycle, the /R/ character is received at 3 LMFC counts before next LMFC boundary, hence the RBD count = 3. In five power cycles, the RBD count varies from 3 to 5. Since there are limited number of power cycles and boards for characterization, 1 LMFC count tolerance is allocated as a guide to set early RBD release opportunity. Hence, setting *csr\_rbd\_offset* = 1 can safely release the elastic buffer 1 LMFC count earlier at LMFC count 7 before the next LMFC boundary. A lane de-skew error occurs when the RBD elastic buffer is released before the latest arrival lane.



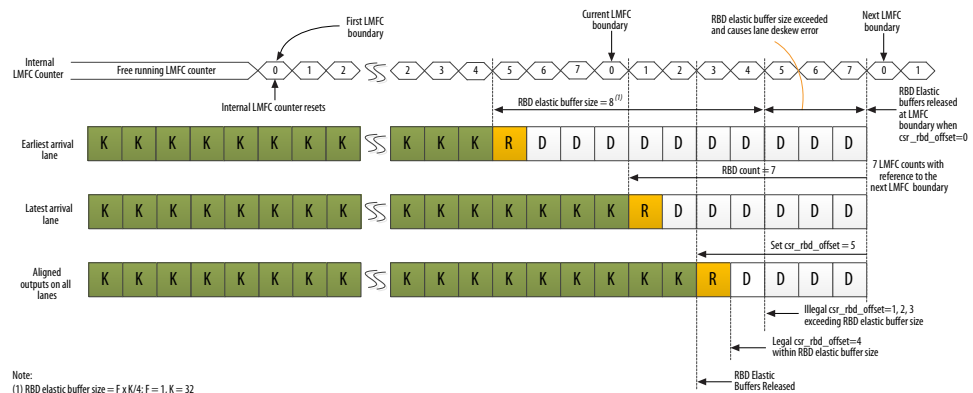
**Figure 27. Early RBD Release Opportunity for Latest Arrival Lane Across Two Local Multi Frames Scenario**

In this example, the RBD count varies from 7 to 1; the /R/ character is received at the previous local multiframe when the RBD count = 1; the /R/ character is received at the current local multiframe when the RBD count = 0 and 7. In this scenario, deterministic latency is not guaranteed because the RBD elastic buffer is released either at the current LMFC boundary when the RBD count = 0 and 1, or one local multiframe period later at the next LMFC boundary when the RBD count = 7. You can fix this issue by setting the RBD offset so that the RBD elastic buffer is always released at the next local multiframe. Setting `csr_rbd_offset = 5` forces the release of RBD elastic buffer 5 LMFC counts before the next LMFC boundary. This corresponds to LMFC count of 3 at the current local multiframe. In this scenario, setting `csr_rbd_offset` not only optimizes user data latency through the IP core, it also resolves the deterministic latency issue.



In the example above, lane deskew error happens if the sum of the difference of /R/ character's LMFC count in the earliest arrival lane to the latest arrival lane, and the number of LMFC count up to the release of RBD elastic buffer exceeds the RBD elastic buffer size. If this is the root cause of lane deskew error, setting RBD offset is one of the techniques to overcome this issue. Not every RBD offset value is legal. Figure below illustrates the technique to decide the legal RBD offset value.

**Figure 28. Selecting Legal RBD Offset Value**



Note:  
(1) RBD elastic buffer size =  $F \times K/4$ ;  $F = 1$ ,  $K = 32$





Because the IP core does not report the position of the earliest lane arrival with respect to the LMFC boundary, you must perform multiple power cycles to observe the RBD count and tune the RBD offset accordingly until no lane deskew error occurs. From the example in the figure above, the recommended RBD offset value is 4 or 5. Setting RBD offset to 1, 2 or 3 is illegal because this exceeds the RBD elastic buffer size for the F and K configurations.

#### Related Information

[SYNC\\_N Signal](#) on page 60

### 5.3. Programmable LMFC Offset

If your JESD204B subsystem design has deterministic latency issue, the programmable LMFC offset in the TX and RX IP cores provides flexibility to ensure that deterministic latency can be achieved.

The TX LMFC offset can align the TX LMFC counter to the LMFC counter in DAC; the RX LMFC offset can align the RX LMFC counter to the LMFC counter in ADC. Phase offset between the TX and RX LMFC counters in the both ends of the JESD204B link contributes to deterministic latency uncertainty. The phase offset is caused by:

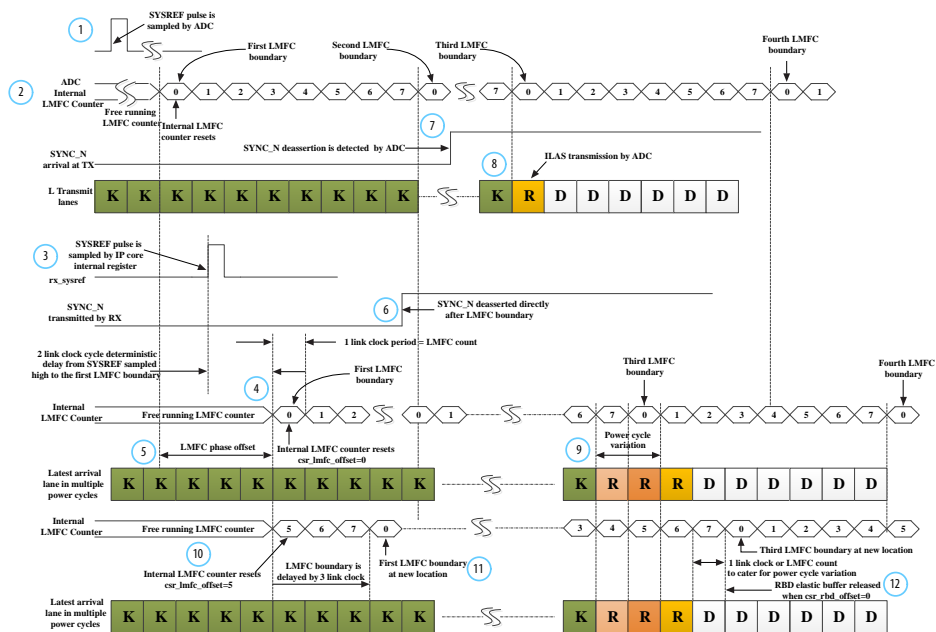
- SYSREF trace length mismatch in the PCB between the TX and RX devices (FPGA and converters).
- delay differences in resetting the LMFC counter when SYSREF pulses are detected by the FPGA and converter devices.

The RX device in the JESD204B link is responsible for deterministic latency adjustments. The following figure illustrates the adjustments that you can make to the RX LMFC offset using the `csr_lmfc_offset` field in the `syncn_sysref_ctrl` register. This is an alternative to using `csr_rbd_offset` to achieve deterministic latency.

Figure 29. Selecting Legal LMFC Offset Value for RX

Sequence of events in the diagram:

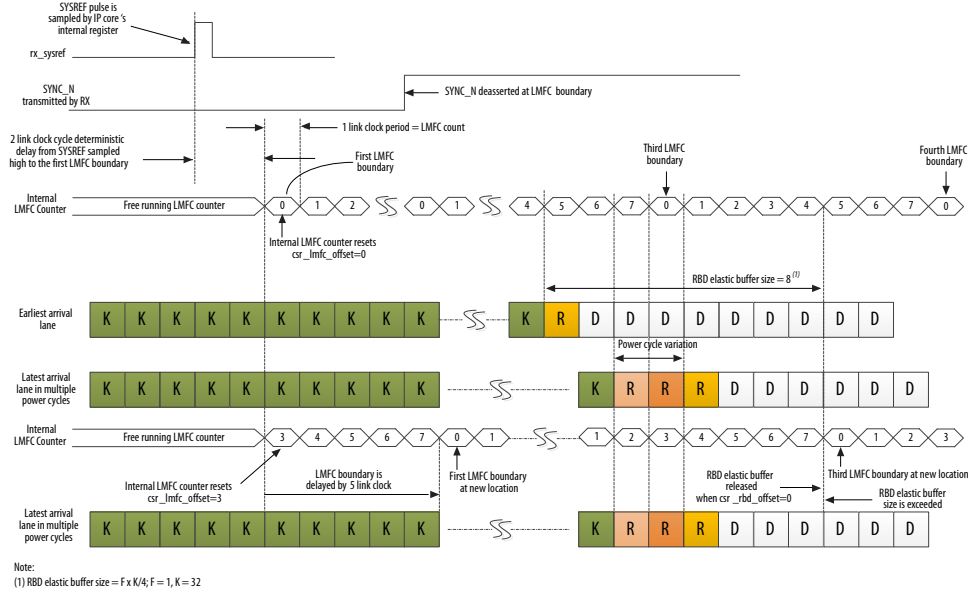
1. Due to trace length mismatch, SYSREF pulse arrives at the ADC first.
2. Some deterministic delay occurs in between the time when the SYSREF pulse is sampled high to the reset of the ADC internal LMFC counter.
3. The SYSREF pulse arrives at the FPGA IP core port, `rx_sysref`, after the pulse's arrival at the ADC.
4. The FPGA IP core's internal LMFC counter resets two link clock cycles after SYSREF is sampled.
5. The LMFC phase offset between the LMFC counter at ADC and FPGA is  $\sim 3.5$  link clock cycles.
6. The FPGA deasserts `SYNC_N` at the LMFC boundary.
7. The ADC JESD204B core detects the `SYNC_N` deassertion.
8. Because `SYNC_N` deassertion is detected after the second LMFC boundary at ADC, ILAS transmission begins at the third LMFC boundary.
9. In this example, the ILAS arrives at the IP core's RBD elastic buffer within one local multiframe. In other system, the arrival at the RBD elastic buffer can span more than one local multiframe. Assuming `csr_rbd_offset = 0`, RBD elastic buffer may be released at the third or fourth LMFC boundary due to power cycle variation.
10. Setting `csr_lmfc_offset = 5` resets the LMFC counter to the value of 5.
11. The first LMFC boundary is delayed by three link clock cycles.
12. The third LMFC boundary has been delayed past the latest arrival lane power cycle variation. The RBD elastic buffer is always released at the third LMFC boundary.



You should set a safe LMFC offset value to ensure deterministic latency from one power cycle to another power cycle. In Figure 30 on page 155, the illegal `csr_lmfc_offset` values of 1, 2, and 3 causes lane de-skew error because the RBD buffer size has exceeded.



Figure 30. Selecting Illegal LMFC Offset Value for RX, Causing Lane Deskew Error

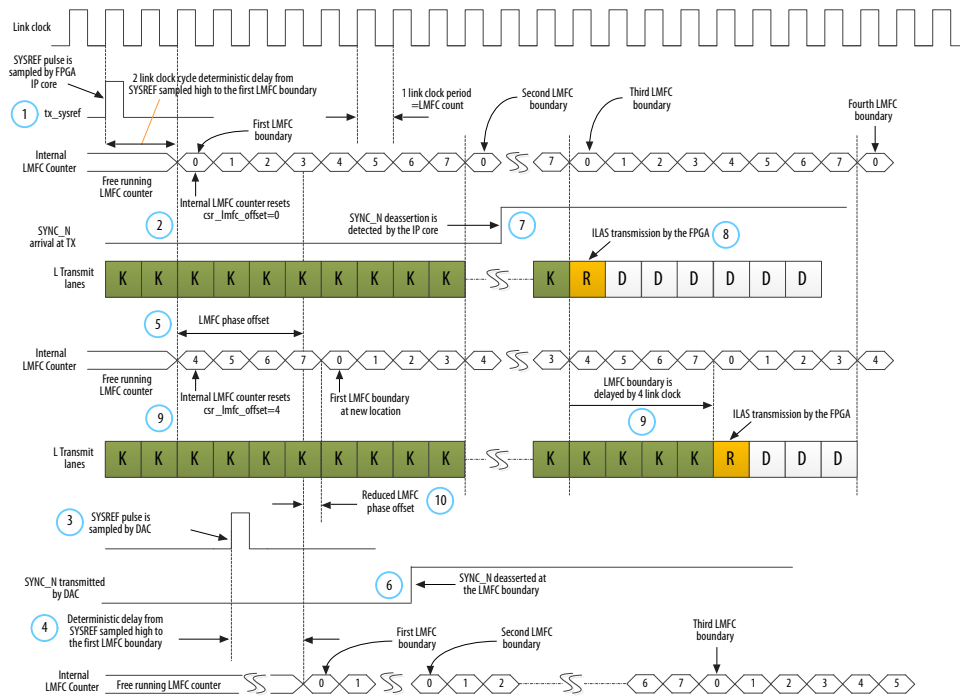


You can use the TX LMFC offset to align the LMFC counter in IP core to the LMFC counter in DAC.

**Figure 31. Example of Reducing LMFC Phase Offset between TX and RX LMFC Counter**

Sequence of events in the diagram:

1. SYSREF pulse arrives at the FPGA IP core port, `tx_sysref`.
2. The IP core's internal LMFC counter resets after two link clock cycles.
3. SYSREF pulse is sampled by the DAC.
4. The DAC's internal LMFC counter resets after a deterministic delay.
5. The LMFC phase offset is  $\sim 3.5$  link clock cycles.
6. The DAC deasserts `SYNC_N` at the LMFC boundary.
7. `SYNC_N` deassertion is detected by the JESD204B IP core.
8. Because `SYNC_N` deassertion is detected after the second LMFC boundary at the FPGA, ILAS transmission begins at the third LMFC boundary.
9. The `csr_lmfc_offset` is set to 4. This delays the TX LMFC boundary by 4 link clock cycles. If `csr_lmfc_offset` is set to 5, the TX LMFC boundary is delayed by 3 link clock cycles.
10. The LMFC phase offset between the TX and RX LMFC reduces to 0.5 link clock cycle.



Alternative to tuning RBD offset at the DAC, adjusting TX LMFC offset in the FPGA helps you to achieve deterministic latency. You should perform multiple power cycles and read the RBD counts at the DAC to determine whether deterministic latency is achieved and RBD elastic buffer size has not exceeded.

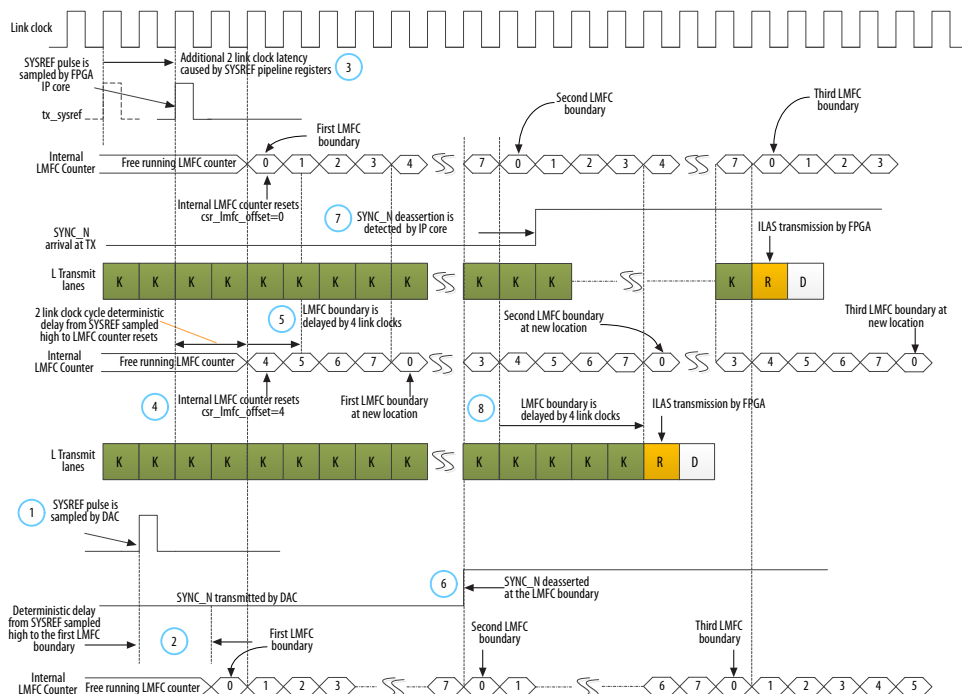
The SYSREF pipeline registers in the FPGA introduce additional latency to SYSREF when detected by the IP core. Therefore, you can use TX LMFC offset to reduce or eliminate this additional latency. The next figure illustrates the technique of optimizing latency using TX LMFC offset.



**Figure 32. Optimizing IP Core Latency Using TX LMFC Offset**

Sequence of events in the diagram:

1. The DAC samples the SYSREF pulse.
2. The DAC's internal LMFC counter resets after a deterministic delay.
3. The SYSREF pipeline registers introduces an additional 2 link clock latency.
4. The `csr_lmfc_offset` field is set to 4. The IP core internal LMFC counter resets after 2 link clock cycles.
5. The LMFC boundary is delayed by 4 link clock.
6. The DAC deasserts SYNC\_N at the LMFC boundary.
7. SYNC\_N deassertion is detected by the JESD204B IP core.
8. Because LMFC boundary is delayed by 4 link clock, the IP core detects the SYNC\_N deassertion before the second LMFC boundary. ILAS transmission begins at the second LMFC boundary instead of the third LMFC boundary (in Figure 31 on page 156). The latency is shortened by 4 LMFC counts or link clock cycles.



The `csr_lmfc_offset` field provides a convenient way to achieve deterministic latency and potentially optimizing the IP core latency. There are other ways that you can achieve deterministic latency by using the features available at the converters. Consult the converter manufacturer for details of these features.

## 5.4. Maintaining Deterministic Latency during Link Reinitialization

Link reinitialization occurs when the RX device deasserts the SYNC\_N signal after link is established.

The converters resample the SYSREF signal and reset the internal LMFC counter. When the link is initially established, the IP core automatically clears the `csr_sysref_singledet` bit in the `syncn_sysref_ctrl` register (address 0x54)



when it detects the *SYSREF* pulse. The IP core does not automatically resample the *SYSREF* pulse unless the `jesd204_tx_avs_rst_n` or `jesd204_rx_avs_rst_n` signal is asserted.

If you are performing a link reset by asserting `txlink_rst_n` or `rxlink_rst_n` to reinitialize the link, set the `csr_sysref_singledet` bit to "1" to force the IP core to resample the *SYSREF* pulse without asserting the `jesd204_tx_avs_rst_n` or `jesd204_rx_avs_rst_n` signal.

## 6. JESD204B IP Debug Guidelines

---

These guidelines assist you in debugging JESD204B link issues. Apart from applying general board level hardware troubleshooting technique like checking the power supply, external clock source, physical damage on components, a fundamental understanding of the JESD204B subsystem operation is important.

### 6.1. Clocking Scheme

To verifying the clocking scheme, follow these steps:

1. Check that the frame and link clock frequency settings are correct in the PLL Intel FPGA IP or IOPLL Intel FPGA IP.
2. Check the device clock frequency at the FPGA and converter.
3. For Subclass 1, check the *SYSREF* pulse frequency.
4. Check the management clock frequency. For the design examples using Arria V, Cyclone V, and Stratix V devices, this frequency is 100 MHz.

### 6.2. JESD204B Parameters

The parameters in both the FPGA and ADC should be set to the same values. For example, when you set  $K = 32$  on the FPGA, set the converter's  $K$  value to 32 as well. Scrambling does not affect the link initialization in the CGS and ILAS phases but in the user data phase. When scrambling is enabled on the ADC, the FPGA descrambling option has to be turned on using the "Enable scramble (SCR)" option in the JESD204B IP core Platform Designer parameter editor. When scrambling is enabled on the FPGA, the DAC descrambling has to be turned on too.

Check these items:

- Turn off the scrambler and descrambler options as needed.
- Use single lane configuration and  $K = 32$  value to isolate multiple lane alignment issue.
- Use Subclass 0 mode to isolate *SYSREF* related issues like setup or hold time and frequency of *SYSREF* pulse.

### 6.3. SPI Programming

The SPI interface configures the converter. Hence, it is important to check the SPI programming sequence and register bit settings for the converter. If you use the MIF to store the SPI register settings of the converter, mistakes may occur when modifying the MIF, for example, setting a certain bit to "1" instead of "0", missing or extra bits in a MIF content row.

Check these items:

- For example, in the ADI AD9250 converter, Intel recommends that you first perform register bit setting for the scramble (SCR) or lane (L) register at address 0x6E before setting the quick configuration register at address 0x5E.
- Determine that each row of the MIF has the same number of bits as the data width of the ROM that stores the MIF.

## 6.4. Converter and FPGA Operating Conditions

The transceiver channels at the converter and FPGA are bounded by minimum and maximum data rate requirements. Always check the most updated device data sheet for this info. For example, the Arria V GT device has a minimum data rate of 611 Mbps.

Ensure that the sampling rate of the converter is within the minimum and maximum requirements. For example, the ADC AD9250 has a minimum sampling rate of 40 Msps. For L = 2, M = 1 configuration, the minimum data rate of this ADC is calculated this way:

$$\text{Minimum AD9250 data rate} = \frac{40 * 1 * 16 * \frac{10}{8}}{2} = 400 \text{ Mbps}$$

The minimum data rate for the JESD204B link is effectively 611 Mbps.

Check these items:

- Reduce the data rate or sampling clock frequency if your targeted operating requirement does not work.
- Verify the minimum and maximum data rate requirements in the device manufacturer's data sheet.

## 6.5. Signal Polarity and FPGA Pin Assignment

Verify that the transceiver channel pin assignments—`SYNC_N` and `SYSREF` (for Subclass 1 only)—device clock, and SPI interface are correct. Also verify the signal polarity of the differential pairs like `SYNC_N` and transceiver channels are correct.

Check these items:

- Review the schematic and board layout file to determine the polarity of the physical pin connection.
- Use assignment editor and pin planner to check the pin assignment and I/O standard for each pin.
- Use RTL viewer in the Intel Quartus Prime software to verify that the top level port are connected to the lower level module that you instantiate.





## 6.6. Creating a Signal Tap Debug File to Match Your Design Hierarchy

The Signal Tap and system console are very useful tools in debugging the JESD204B link related issues. The Signal Tap provides a dynamic view of signals.

For Intel Arria 10, Intel Cyclone 10 GX, and Intel Stratix 10 devices, the Intel Quartus Prime software generates two files, `build_stp.tcl` and `<ip_core_name>.xml`. You can use these files to generate a Signal Tap file with probe points matching your design hierarchy.

The Intel Quartus Prime software stores these files in the `<debug stp directory>`. The `<debug stp directory>` is defined based on JESD204B wrapper and data path.

**Table 90. File Directory**

JESD204B Wrapper	Data Path	Debug stp directory
Both Base and PHY	Transmitter/ Duplex	<code>&lt;ip_variant_name&gt;/ altera_jesd204_tx_mlpcs_&lt;Quartus_version&gt;/synth/debug/stp</code>
	Receiver	<code>&lt;ip_variant_name&gt;/ altera_jesd204_rx_mlpcs_&lt;Quartus_version&gt;/synth/debug/stp</code>
Base only	Transmitter	<code>&lt;ip_variant_name&gt;/altera_jesd204_tx_&lt;Quartus_version&gt;/synth/ debug/stp</code>
	Receiver	<code>&lt;ip_variant_name&gt;/altera_jesd204_rx_&lt;Quartus_version&gt;/synth/ debug/stp</code>

Synthesize your design by running Analysis and Synthesis in the Intel Quartus Prime software.

1. Run analysis and synthesis.
2. Then open the Tcl console by clicking **View** ► **Utility Windows** ► **Tcl Console**.
3. Navigate to the `<debug stp directory>` as shown in [Table 90](#) on page 161.
4. Type the following command in the Tcl console:

```
source build_stp.tcl
```

5. To generate the STP file, type the following command:

```
main -stp_file <stp file name>.stp -xml_file  
<xml_file name>.xml -mode build
```

The `<stp file name>.stp` file is generated in the `<debug stp directory>`.

6. The software generation script may not assign the Signal Tap acquisition clock in the `<stp file name>.stp` file. Consequently, the Intel Quartus Prime software automatically creates a clock pin (`auto_stp_external_clock`) for each instance. To assign an acquisition clock for the generated STP file, Intel recommends that you perform the following assignments:

JESD204B Duplex & Simplex (Both Base & PHY) or (PHY only) IP core:-

- For rx\_link instance, assign the rxlink\_clk signal.
- For tx\_link instance, assign the txlink\_clk signal.
- For all supported devices, except Intel Stratix 10 E-tile devices:  
For rx\_phy and tx\_phy instances, assign the input clock of the transceiver reset controller.
- For Intel Stratix 10 E-tile devices:  
For rx\_phy and tx\_phy instances, assign rxphy\_clk[0] and txphy\_clk[0] as the acquisition clock. Then, add the following set\_false\_path constraint in the SDC script.

```
set_false_path -from
```

```
<instance_name>|inst_phy|inst_xcvr|*counter_*x_ready|r_reset -to
```

```
auto_fab*sld_signaltap_inst*
```

*Note:* The PHY signals are different for Intel Stratix 10 E-tile devices. Remove the irrelevant signals and add the Intel Stratix 10 E-tile device PHY signals into the Signal Tap Logic Analyzer.

JESD204B Simplex (Base only) IP core:-

- For rx\_link instance, assign the rxlink\_clk signal.
- For tx\_link instance, assign the txlink\_clk signal.

*Note:* The GUI parameter editor allows you to choose the appropriate instance for each IP core name if your design contains more than one JESD204B instances. For simplex core, you need to choose the RX instance followed by TX instance to generate the proper STP file.

7. Click **Save** to save the modified STP. A dialog box pops up with a message "Do you want to enable Signal Tap File "<stp file name>" for the current project?". Click **Yes**. Then, compile your design.
8. To program the FPGA, click **Tools > Programmer**.
9. Open the generated STP file again if it has closed after step 6.
10. To observe the state of your IP core, click **Run Analysis** in the Signal Tap Logic Analyzer.

You may see signals or Signal Tap instances that are red, indicating they are not available in your design. In most cases, you can safely ignore these signals and instances because the software generates wider buses and certain instances that your design does not include.

## 6.7. Debugging JESD204B Link Using System Console

The system console provides access to the JESD204B IP register sets through the Avalon-MM interfaces.

To use the system console, your design must contain a Platform Designer subsystem with the JTAG-to-Avalon-MM Master bridge or Nios II Processor component. Connect the JESD204B IP Avalon-MM interface to the Avalon-MM master through the Platform Designer interconnect directly if the IP resides in the Platform Designer subsystem. Otherwise, connect the Avalon-MM interface through the Merlin slave translator if the IP is not part of the Platform Designer subsystem.



### PHY Layer for All Devices Except Intel Stratix 10 E-tile Devices

Verify the PHY status through these signals in the `<ip_variant_name>.v`:

**Table 91. PHY Status Signals for All Supported Devices Except Intel Stratix 10 E-tile Devices**

Design	Signals
RX	<ul style="list-style-type: none"> <li>rx_is_lockedtodata</li> <li>rx_analogreset</li> <li>rx_digitalreset</li> <li>rx_cal_busy</li> </ul>
TX	<ul style="list-style-type: none"> <li>pll_locked</li> <li>pll_powerdown</li> <li>tx_analogreset</li> <li>tx_digitalreset</li> <li>tx_cal_busy</li> </ul>
RX and TX (Duplex)	<ul style="list-style-type: none"> <li>rx_is_lockedtodata</li> <li>rx_analogreset</li> <li>rx_digitalreset</li> <li>rx_cal_busy</li> <li>rx_serialpbken</li> <li>pll_locked</li> <li>pll_powerdown</li> <li>tx_analogreset</li> <li>tx_digitalreset</li> <li>tx_cal_busy</li> </ul>

Use the `rxphy_clk[0]` or `txphy_clk[0]` signal as sampling clock for the Signal Tap Logic Analyzer.

For a normal operation of the JESD204B RX path, the `rx_is_lockedtodata` bit for each lane should be "1" while the `rx_cal_busy`, `rx_analogreset`, and `rx_digitalreset` bit for each lane should be "0".

For a normal operation of the JESD204B TX path, the `pll_locked` bit for each lane should be "1" while the `tx_cal_busy`, `pll_powerdown`, `tx_analogreset`, and `tx_digitalreset` bit for each lane should be "0".

Measure the `rxphy_clk` or `txphy_clk` frequency by connecting the clock to the CLKOUT pin on the FPGA. The frequency should be the same as link clock frequency for PCS option in Hard PCS or Soft PCS mode. The frequency is half of the link clock frequency for PCS option in PMA Direct mode.

### PHY Layer for Intel Stratix 10 E-tile Devices

Verify the PHY status through these signals in the `<ip_variant_name>.v`:

**Table 92. PHY Status Signals for Intel Stratix 10 E-tile Devices**

Design	Signals
RX	<ul style="list-style-type: none"> <li>rx_is_lockedtodata</li> <li>phy_rx_ready</li> <li>phy_rx_pma_ready</li> </ul>
TX	<ul style="list-style-type: none"> <li>phy_tx_ready</li> <li>phy_tx_pma_ready</li> </ul>

Use the `rxphy_clk[0]` or `txphy_clk[0]` signal as the acquisition clock. Then add the following `set_false_path` constraint in the SDC script.

```
set_false_path -from
<instance_name>|inst_phy|inst_xcvr|*counter_*x_ready|r_reset -to
auto_fab*sld_signaltap_inst*
```

For a normal operation of the JESD204B RX path, the `phy_rx_pma_ready`, `phy_rx_ready` and the `rx_islockedtodata` bits for each lane should be "1".

For a normal operation of the JESD204B TX path, the `phy_tx_pma_ready` and `phy_tx_ready` bits for each lane should be "1".

Measure the `rxphy_clk` or `txphy_clk` frequency by connecting the clock to the CLKOUT pin on the FPGA. The frequency should be the same as link clock frequency.

### Link Layer

Verify the RX and TX PHY-link layer interface operation through these signals in the `<ip_variant_name>_inst_phy.v`:

**Table 93. RX and TX PHY-Link Layer Signals**

Design	Signals
RX	<ul style="list-style-type: none"> <li>jesd204_rx_pcs_data</li> <li>jesd204_rx_pcs_data_valid</li> <li>jesd204_rx_pcs_kchar_data</li> <li>jesd204_rx_pcs_errdetect</li> <li>jesd204_rx_pcs_disperr</li> </ul>
TX	<ul style="list-style-type: none"> <li>jesd204_tx_pcs_data</li> <li>jesd204_tx_pcs_kchar_data</li> </ul>



Verify the link layer operation through these signals in the `<ip_variant_name>.v`:

**Table 94. RX and TX Link Layer Signals**

Design	Signals
RX	<ul style="list-style-type: none"> <li>• jesd204_rx_avs_rst_n</li> <li>• rxlink_rst_n_reset_n</li> <li>• rx_sysref (for Subclass 1 only)</li> <li>• rx_dev_sync_n</li> <li>• jesd204_rx_int</li> <li>• alldev_lane_aligned</li> <li>• dev_lane_aligned</li> <li>• rx_somf</li> </ul> Use the <code>rxlink_clk</code> signal as the sampling clock.
TX	<ul style="list-style-type: none"> <li>• jesd204_tx_avs_rst_n</li> <li>• txlink_rst_n_reset_n</li> <li>• tx_sysref (for Subclass 1 only)</li> <li>• sync_n</li> <li>• tx_dev_sync_n</li> <li>• mdev_sync_n</li> <li>• jesd204_tx_int</li> </ul>

Intel recommends that you verify the JESD204B functionality by accessing the DAC SPI registers or any debug feature provided by the DAC manufacturer.

**Figure 33. JESD204B Link Initialization**

This is a Signal Tap image during the JESD204B link initialization. The JESD204B link has two transceiver channels (L = 2).



Description of the timing diagram:

- a. The JESD204B link is out of reset.
- b. The RX CDR is locked and PCS outputs valid characters to link layer.
- c. No running disparity error and 8B/10B block within PCS successfully decodes the incoming characters.
- d. The ADC transmits /K/ character or BC hexadecimal number to the FPGA, which starts the CGS phase.
- e. Upon receiving 4 consecutive /K/ characters, the link layer deasserts the rx\_dev\_sync\_n signal.
- f. The JESD204B link transition from CGS to ILAS phase when ADC transmit /R/ or 1C hexadecimal after /K/ character.
- g. Start of 2<sup>nd</sup> multiframe in ILAS phase. 2<sup>nd</sup> multiframe contains the JESD204B link configuration data.
- h. Start of 3<sup>rd</sup> multiframe.
- i. Start of 4<sup>th</sup> multiframe.
- j. Device lanes alignment is achieved. In this example, there is only one device, the dev\_lane\_aligned connects to alldev\_lane\_aligned and both signals are asserted together.
- k. Start of user data phase where user data is streamed through the JESD204B link.



### Transport Layer

Verify the RX transport layer operation using these signals in the **altera\_jesd204\_transport\_rx\_top.sv**:

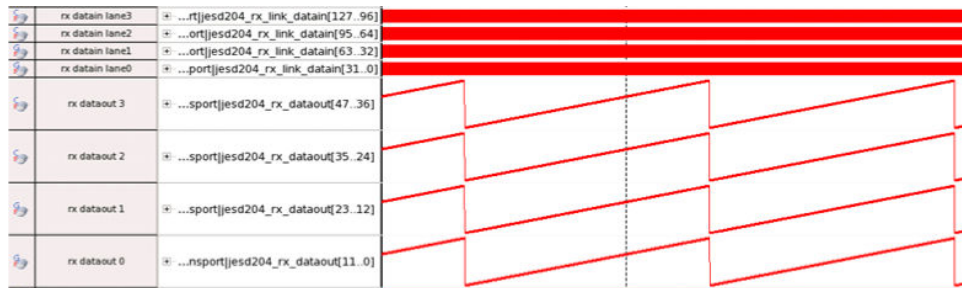
- jesd204\_rx\_dataout
- jesd204\_rx\_data\_valid
- jesd204\_rx\_data\_ready
- jesd204\_rx\_link\_data\_ready
- jesd204\_rx\_link\_error
- rxframe\_rst\_n

Use the rxframe\_clk signal as the sampling clock.

For normal operation, the jesd204\_rx\_data\_valid, jesd204\_rx\_data\_ready, and jesd204\_rx\_link\_data\_ready signals should be asserted while the jesd204\_rx\_link\_error should be deasserted. You can view the ramp or sine wave test pattern on the jesd204\_rx\_dataout bus.

**Figure 34. Ramp Pattern on the jesd204\_rx\_dataout Bus**

This is a Signal Tap II image during the JESD204B user data phase with ramp pattern transmitted from the ADC.



Verify the TX transport layer operation using these signals in the **altera\_jesd204\_transport\_tx\_top.sv**:

- txframe\_rst\_n
- jesd204\_tx\_datain
- jesd204\_tx\_data\_valid
- jesd204\_tx\_data\_ready
- jesd204\_tx\_link\_early\_ready
- jesd204\_tx\_link\_data\_valid
- jesd204\_tx\_link\_error

Use the txframe\_clk signal as the sampling clock.

For normal operation, the jesd204\_tx\_data\_valid, jesd204\_tx\_data\_ready, jesd204\_tx\_link\_early\_ready, and jesd204\_tx\_link\_data\_valid signals should be asserted while the jesd204\_tx\_link\_error should be deasserted. You



can verify the user data arrangement (shown in the data mapping tables in the *TX Path Data Remapping* section in the *Design Examples for JESD204B IP Core User Guide*) by referring to the `jesd204_tx_datain` bus.

### Related Information

- [V-Series Transceiver PHY User Guide](#)
- [Intel Arria 10 Transceiver PHY User Guide](#)
- [Intel Cyclone 10 GX Transceiver PHY User Guide](#)
- [Intel Stratix 10 L- and H-tile Transceiver PHY User Guide](#)
- [E-tile Transceiver PHY User Guide](#)
- [AN 696: Using the JESD204B MegaCore Function in Arria V Devices](#)  
More information about the performance and interoperability of the JESD204B IP core.
- [AN 729: Implementing JESD204B IP Core System Reference Design with Nios II Processor As Control Unit](#)  
An example of implementing a full-featured software control flow with various user commands in a JESD204B system that incorporates a Nios II processor
- [JESD204B Reference Design](#)  
Available design examples in Intel FPGA Design Store.
- [Design Examples for JESD204B IP Core User Guide](#)  
More information about the TX path data remapping in the Transport Layer.
- [JESD204B Intel Arria 10 FPGA IP Design Example User Guide](#)
- [JESD204B Intel Stratix 10 FPGA IP Design Example User Guide](#)
- [JESD204B Intel Cyclone 10 FPGA IP Design Example User Guide](#)





## 7. JESD204B Intel FPGA IP User Guide Archives

---

IP versions are the same as the Intel Quartus Prime Design Suite software versions up to 19.1. From Intel Quartus Prime Design Suite software version 19.2 or later, IP cores have a new IP versioning scheme.

If an IP core version is not listed, the user guide for the previous IP core version applies.

IP Core Version	User Guide
19.1	<a href="#">JESD204B Intel FPGA IP User Guide</a>
18.1	<a href="#">JESD204B Intel FPGA IP User Guide</a>
18.0	<a href="#">JESD204B Intel FPGA IP User Guide</a>
17.1	<a href="#">JESD204B IP Core User Guide</a>
17.0	<a href="#">JESD204B IP Core User Guide</a>
16.1	<a href="#">JESD204B IP Core User Guide</a>
16.0	<a href="#">JESD204B IP Core User Guide</a>

## 8. Document Revision History for the JESD204B Intel FPGA IP User Guide

Document Version	Intel Quartus Prime Version	IP Version	Changes
2020.03.03	19.4	19.2.0	Edited the <b>Enable Bit reversal and Byte reversal</b> parameter description in the <i>JESD204B Intel FPGA IP Parameters</i> section.
2019.12.16	19.4	19.2.0	<ul style="list-style-type: none"> <li>Updated the supported maximum data rate to 19.2 Gbps (for Intel Agilex devices) in the <i>JESD204B IP Quick Reference</i>, <i>About the JESD204B Intel FPGA IP</i>, and <i>Performance and Resource Utilization</i> sections.</li> <li>Updated the maximum data rate value option to 19.2 Gbps for Intel Agilex devices for the <b>Data Rate</b> parameter and edited the <b>Enable Bit reversal and Byte reversal</b> parameter description in the <i>JESD204B Intel FPGA IP Parameters</i> section.</li> </ul>
2019.10.07	19.3	19.2.0	<ul style="list-style-type: none"> <li>Added advance support for Intel Agilex devices.</li> <li>Updated the supported maximum data rate to 17.4 Gbps (for Intel Agilex devices) in the <i>JESD204B IP Quick Reference</i> and <i>About the JESD204B Intel FPGA IP</i> sections.</li> <li>Updated the <i>JESD204B Intel FPGA IP Performance</i> table in the <i>Performance and Resource Utilization</i> section with Intel Agilex devices information.</li> <li>Updated the maximum data rate value option to 17.4 Gbps for Intel Agilex devices in the <i>JESD204B Intel FPGA IP Parameters</i> section.</li> <li>Added a reference link to the <i>JESD204B Intel Agilex FPGA IP Design Example User Guide</i>.</li> </ul>
2019.05.27	19.1	-	Corrected typos in the <i>Transmitter Registers</i> and <i>Receiver Registers</i> sections; changed LEMC to LMFC.
2019.04.01	19.1	-	<ul style="list-style-type: none"> <li>Added support for Intel Stratix 10 E-tile devices.</li> <li>Revised the resource utilization data for version 19.1 in the <i>Performance and Resource Utilization</i> section.</li> <li>Updated the <i>JESD204B Intel FPGA IP Performance</i> table with Intel Stratix 10 E-tile device information in the <i>Performance and Resource Utilization</i> section.</li> <li>Updated the <i>Channel Bonding</i> section to include information about Intel Stratix 10 E-tile devices. For Intel Stratix 10 E-tile devices, you must use contiguous channels to enable channel bonding with NRZ PMA transceiver channels.</li> <li>Added the <b>Transceiver Tile</b> option which is available when you target an Intel Stratix 10 device that supports both and H-tile and E-tile.</li> </ul>

continued...

Intel Corporation. All rights reserved. Agilex, Altera, Arria, Cyclone, Enpirion, Intel, the Intel logo, MAX, Nios, Quartus and Stratix words and logos are trademarks of Intel Corporation or its subsidiaries in the U.S. and/or other countries. Intel warrants performance of its FPGA and semiconductor products to current specifications in accordance with Intel's standard warranty, but reserves the right to make changes to any products and services at any time without notice. Intel assumes no responsibility or liability arising out of the application or use of any information, product, or service described herein except as expressly agreed to in writing by Intel. Intel customers are advised to obtain the latest version of device specifications before relying on any published information and before placing orders for products or services.

\*Other names and brands may be claimed as the property of others.



Document Version	Intel Quartus Prime Version	IP Version	Changes
			<ul style="list-style-type: none"> <li>• Renamed the <b>Enable Altera Debug Master Endpoint</b> parameter to <b>Enable Native PHY Debug Master Endpoint</b> as per Intel rebranding in the Intel Quartus Prime Pro Edition software. The Intel Quartus Prime Standard Edition software still uses <b>Enable Altera Debug Master Endpoint</b>.</li> <li>• Added a note to refer to the <i>PMA Adaptation</i> section in the <i>Intel Stratix 10 E-tile Transceiver PHY User Guide</i> for more information about <b>PMA Adaptation</b> parameters.</li> <li>• Edited the <i>Transmitter Signals</i> and <i>Receiver Signals</i> sections to add a note that certain signals are not applicable for Intel Stratix 10 E-tile devices or applicable only for Intel Stratix 10 L-tile and H-tile devices.</li> <li>• Added the following signals that are applicable only for Intel Stratix 10 E-tile devices in the <i>Transmitter Signals</i> and <i>Receiver Signals</i> sections:                         <ul style="list-style-type: none"> <li>– phy_tx_ready</li> <li>– phy_rx_ready</li> <li>– phy_tx_pma_ready</li> <li>– phy_rx_pma_ready</li> <li>– phy_tx_rst_n</li> <li>– phy_rx_rst_n</li> <li>– tx_serial_data_n</li> <li>– rx_serial_data_n</li> </ul> </li> <li>• Added a note in the <i>Pin Assignments</i> section to use the <i>E-Tile Channel Placement Tool</i> to get a valid pinout for Intel Stratix 10 E-tile devices.</li> <li>• Added a note in the <i>Adding External Transceiver PLLs</i> section that Intel Stratix 10 E-tile device designs do not require external PLLs.</li> <li>• Added a note in the <i>Simulating the IP Core Testbench</i> section that Intel Stratix 10 E-tile devices do not support the Riviera-PRO simulator.</li> <li>• Add information about Intel Stratix 10 E-tile devices in the <i>Testbench Simulation Flow</i> section.</li> <li>• Edited the <i>Creating a Debug File to Match Your Design Hierarchy</i> section to add information about Intel Stratix 10 E-tile devices.</li> <li>• Edited the <i>Debugging JESD204B Link Using System Console</i> section to add information about Intel Stratix 10 E-tile devices.</li> <li>• Added the <i>Transmitter Registers</i> and <i>Receiver Registers</i> sections in the <i>Registers</i> chapter. The register information are now available in the document.</li> </ul>
2018.12.10	18.1	–	<ul style="list-style-type: none"> <li>• Updated the <i>Device Family Support</i> section to indicate that the JESD204B Intel FPGA IP core supports only Intel Stratix 10 (L-tile and H-tile) devices.</li> <li>• Revised the data rate information for Intel Stratix 10 devices for speed grade 2 and 3.</li> <li>• Revised the resource utilization data and speed grade information for version 18.1.</li> <li>• Added resource utilization data and speed grade information for Intel Stratix 10 devices when number of octets per frame (F) is 3.</li> </ul>

*continued...*



Document Version	Intel Quartus Prime Version	IP Version	Changes
			<ul style="list-style-type: none"> <li>Updated the <b>Octets per frame (F)</b> parameter option to support F=3 in the <i>JESD204B IP Core Parameter</i> section. F=3 is available only for Intel Stratix 10 devices.</li> <li>Categorized the following signals as debug and testing signals in the <i>Transmitter Signals</i> section:               <ul style="list-style-type: none"> <li>csr_tx_testmode[3:0]</li> <li>csr_tx_testpattern_a[ ]</li> <li>csr_tx_testpattern_b[ ]</li> <li>csr_tx_testpattern_c[ ]</li> <li>csr_tx_testpattern_d[ ]</li> </ul> </li> <li>Categorized the <i>csr_rx_testmode[3:0]</i> signal as a debug and testing signal in the <i>Receiver Signals</i> section.</li> <li>Added a note in the <i>Receiver Signals</i> section that the test pattern checker is a component in the design example and is not a part of the JESD204B IP core</li> <li>Added a note in the <i>Transmitter Signals</i> section that the test pattern generator is a component in the design example and is not a part of the JESD204B IP core</li> <li>Edited the steps for running analysis and synthesis in the <i>Creating a Signal Tap Debug File to Match Your Design</i> section.</li> </ul>
2018.05.07	18.0	-	<ul style="list-style-type: none"> <li>Renamed JESD204B IP core to JESD204B Intel FPGA IP as per Intel rebranding.</li> <li>Added support for Intel Cyclone 10 GX devices.</li> <li>Added simulation setup and run scripts for the Cadence Xcelium Parallel simulator.</li> <li>Added links to the <i>JESD204B Intel FPGA IP Design Example for Intel Cyclone 10 GX Devices User Guide</i>.</li> <li>Edited a typo in in the <i>Brief Information About the JESD204B IP Core</i> table. Changed Platform Designer (Standard) to Platform Designer.</li> <li>Revised the resource utilization data and speed grade information for version 18.0.</li> <li>Updated the <i>JESD204B IP Core Parameters</i> and <i>Signals</i> sections with Intel Cyclone 10 GX information.</li> <li>Edited the steps in the <i>Creating a Signal Tap Debug File to Match Your Design Hierarchy</i> section.</li> <li>Added a note in the <i>Testbench Simulation Flow</i> section that for Intel Stratix 10 devices, reset deassertion staggering of TX/RX analog and digital reset happens before the assertion of TX/RX ready.</li> </ul>

Date	Version	Changes
November 2017	2017.11.06	<ul style="list-style-type: none"> <li>Updated <i>alldev_lane_aligned</i> signal description.</li> <li>Updated bonded channel requirements for Intel Stratix 10 and Intel Arria 10 devices.</li> <li>Updated instances of Qsys to Platform Designer.</li> <li>Updated steps to simulate the testbench design using the Aldec Riviera-PRO simulator.</li> <li>Removed note stating that the dynamic reconfiguration is not supported for the JESD204B IP core testbench.</li> </ul>

*continued...*



Date	Version	Changes
		<ul style="list-style-type: none"> <li>Added Base only, or Simplex TX configuration in <i>Preset Configurations for JESD204B IP Core Testbench</i> table.</li> <li>Added Provide Separate Reconfiguration Interface for Each Channel parameter in the <i>JESD204B IP Core Parameters</i> table.</li> <li>Updated Link Clock <math>F_{MAX}</math> (MHz) for all devices in the <i>JESD204B IP Core FPGA Performance</i> table.</li> <li>Added supported data rate note to Intel Arria 10 variants in <i>JESD204B IP Core FPGA Performance</i> table.</li> <li>Updated rx_phy and tx_phy assignments in <i>Creating a Signal Tap Debug File to Match Your Design Hierarchy</i>.</li> <li>Updated the data rate support for Intel Stratix 10 devices:                             <ul style="list-style-type: none"> <li>For speed grade 1 to up to 16.0 Gbps.</li> <li>For speed grade 2 to up to 13.5 Gbps.</li> <li>For speed grade 3 to up to 12.5 Gbps.</li> </ul> </li> <li>Updated and added example timing diagrams in <i>Subclass 2 Operating Mode</i> subsection.</li> <li>Updated transceiver interface signals for transmitter and receiver signals.</li> </ul>
May 2017	2017.05.08	<ul style="list-style-type: none"> <li>Updated description for PLL/CDR Reference Clock Frequency in <i>JESD204B IP Core Parameters</i>.</li> <li>Added <code>somE[ ]</code> for transmitter signal.</li> <li>Updated <i>Run-Time Configuration</i> to include statement on JESD204B IP core parameterization for Intel Stratix 10 devices.</li> <li>Added note to <i>Registers</i> to indicate that disabled run-time access for registers in Intel Stratix 10 devices.</li> <li>Updated data path preset value to simplex TX and simplex RX in <i>Preset Configurations for JESD204B IP Core Testbench</i> table.</li> <li>Clarified the device family support for Stratix 10 devices.</li> <li>Added Transmitter and Receiver signal diagrams.</li> <li>Added <b>Share Reconfiguration Interface</b> parameter in <i>JESD204B IP Core Parameters</i> table.</li> <li>Added note and description to Share Reconfiguration Interface in <i>JESD204B IP Core Parameters</i>.</li> <li>Added links to <i>Stratix 10 device Datasheet</i>, <i>Stratix 10 L-Tile Transceiver PHY User Guide</i>, and <i>Stratix 10 H-Tile Transceiver PHY User Guide</i>.</li> <li>Added tx_analogreset_stat, rx_analogreset_stat, tx_digitalreset_stat, and rx_digitalreset_stat signals and descriptions.</li> <li>Updated <i>ADC-FPGA Subsystem Reset Scheme</i> and <i>FPGA-DAC Subsystem Reset Scheme</i>.</li> </ul>
October 2016	2016.10.31	<ul style="list-style-type: none"> <li>Updated <i>Example 2</i> in <i>Clock Correlation</i>.</li> <li>Updated steps in <i>FPGA-DAC Subsystem Reset Sequence</i>.</li> <li>Updated figure and title for <i>JESD204B Subsystem with Shared Transceiver Reference Clock and Core Clock</i> and <i>JESD204B Subsystem with Separate Transceiver Reference Clock and Core Clock</i>.</li> <li>Updated <i>Subclass 1 Deterministic Latency and Support for Programmable Release Opportunity</i> figure.</li> <li>Updated <i>Channel Bonding</i> description.</li> </ul>
May 2016	2016.05.02	<ul style="list-style-type: none"> <li>Updated the IP Core release information.</li> <li>Updated the data rate support—uncharacterized support for data rates of up to 15 Gbps.</li> <li>Updated the data rate for Intel Arria 10 and Arria V GT/ST in the <i>JESD204B IP Core FPGA Performance</i> table.</li> <li>Updated the <i>JESD204B IP Core FPGA Resource Utilization</i> table.</li> <li>Updated the <b>PLL/CDR Reference Clock Frequency</b> parameter description.</li> </ul>

continued...



Date	Version	Changes
		<ul style="list-style-type: none"> <li>• Updated the preset values for <b>PLL/CDR Reference Clock Frequency</b>, <b>Link Clock</b>, and <b>AVS Clock</b> in Table 3-8: Preset Configurations for JESD204B IP Core Testbench.</li> <li>• Updated Figure 4-8 to illustrate shared clocking and renamed the title to "JESD204B Subsystem with Shared Transceiver Reference Clock and Core Clock".</li> <li>• Added a new figure to illustrate separate clocking—<i>Figure 4-9: JESD204B Subsystem with Separate Transceiver Reference Clock and Core Clock</i>.</li> <li>• Added new sections:               <ul style="list-style-type: none"> <li>— <a href="#">ADC-FPGA Subsystem Reset Sequence</a> on page 72</li> <li>— <a href="#">FPGA-DAC Subsystem Reset Sequence</a> on page 74</li> <li>— <a href="#">Creating a Signal Tap Debug File to Match Your Design Hierarchy</a> on page 161</li> </ul> </li> <li>• Updated the TX path <b>CONTROL_BUS_WIDTH</b> parameter description.</li> <li>• Revised the clock domain for <code>jesd204_tx_data_ready</code> signal to <code>txframe_clk</code>.</li> <li>• Updated the description for the following registers in the register map:               <ul style="list-style-type: none"> <li>— <code>rx_regmap</code>:                   <ul style="list-style-type: none"> <li>• <code>csr_frame_data_ready_err</code></li> <li>• <code>csr_pcfifo_full_err</code></li> <li>• <code>csr_pcfifo_empty_err</code></li> </ul> </li> <li>— <code>tx_regmap</code>:                   <ul style="list-style-type: none"> <li>• <code>csr_pcfifo_full_err</code></li> <li>• <code>csr_pcfifo_empty_err</code></li> </ul> </li> </ul> </li> <li>• Added links to archived document in <a href="#">JESD204B Intel FPGA IP User Guide Archives</a> on page 169.</li> </ul>
November 2015	2015.11.02	<ul style="list-style-type: none"> <li>• Added data rate support of up to 13.5 Gbps for Intel Arria 10 and 7.5 Gbps for Arria V GT/ST devices.</li> <li>• Updated the IP core FPGA performance and resource utilization values.</li> <li>• Added a new table to define the clock network selection for bonded mode in channel bonding.</li> <li>• Added a new selection for <b>PCS Option</b> parameter—Enabled PMA Direct.</li> <li>• Updated the preset value for link clock in <a href="#">JESD204B IP Testbench</a> on page 41.</li> <li>• Updated the formula and description for TX/RX PHY clock.</li> <li>• Updated the device clock section to recommend user to supply the device clock with the same frequency as the link clock.</li> <li>• Updated the description of <code>txlink_clk</code>, <code>txphy_clk[]</code>, and <code>rxphy_clk[]</code> signals.</li> <li>• Changed the default value for RX Phase Compensation FIFO empty error enable (<code>csr_pcfifo_empty_err_en</code>) CSR to 0. Refer to the <i>RX register map</i> for details.</li> <li>• Added a new section—<i>Design Example with Nios II Processor Control Unit</i>.</li> <li>• Added a new topic – <a href="#">Maintaining Deterministic Latency during Link Reinitialization</a> on page 157.</li> <li>• Changed instances of <i>Quartus II</i> to <i>Quartus Prime</i>.</li> </ul>
May 2015	2015.05.04	<ul style="list-style-type: none"> <li>• Added support for Cyclone V FPGA device family.</li> <li>• Updated the JESD204B IP Core Configuration values:               <ul style="list-style-type: none"> <li>— M value from 1-32 to 1-256</li> <li>— N' value from 4-32 to 1-32</li> </ul> </li> <li>• Updated the JESD204B IP Core FPGA Performance table.</li> <li>• Updated the JESD204B IP Core FPGA Resource Utilization table.</li> </ul>

*continued...*



Date	Version	Changes
		<ul style="list-style-type: none"> <li>• Added new parameters to the JESD204B IP Core Parameters table:                             <ul style="list-style-type: none"> <li>– <b>Enable Capability Registers</b></li> <li>– <b>Set user-defined IP identifier</b></li> <li>– <b>Enable Control and Status Registers</b></li> <li>– <b>Enable Prbs Soft Accumulators</b></li> <li>– <b>Enable manual F configuration</b></li> </ul> </li> <li>• Added new topics:                             <ul style="list-style-type: none"> <li>– <a href="#">Timing Constraints For Input Clocks</a> on page 33</li> <li>– <a href="#">JESD204B IP Deterministic Latency Implementation Guidelines</a> on page 149</li> </ul> </li> <li>• Revised the note in "Simulating the IP Core Testbench" to state that VHDL is not supported in Aldec Riviera (for Intel Arria 10 devices only).</li> <li>• Updated the <i>Control Unit Process Flow</i> diagram.</li> </ul>
December 2014	2014.12.15	<ul style="list-style-type: none"> <li>• Updated the JESD204B IP Core FPGA Performance table with the data rate range.</li> <li>• Updated the JESD204B IP Core FPGA Resource Utilization table.</li> <li>• Updated the JESD204B IP Core Parameters table with the following changes:                             <ul style="list-style-type: none"> <li>– Revised the parameter name of <b>Enable PLL/CDR Dynamic Reconfiguration</b> to <b>Enable Transceiver Dynamic Reconfiguration</b>.</li> <li>– Added information for a new parameter—<b>Enable Altera Debug Master Endpoint</b>.</li> <li>– Added details about the rule check for parameter N' value.</li> </ul> </li> <li>• Added a new topic—<a href="#">Integrating the JESD204B IP in Platform Designer</a> on page 31.</li> <li>• Updated <i>Overview of the JESD204B IP Core Block Diagram, Transmitter Data Path Block Diagram, and Receiver Data Path Block Diagram</i>.</li> <li>• Added a new table—Register Access Type Convention—to describe the access type for the IP core registers.</li> <li>• Added new signals description for <code>jesd204_tx_controlout</code> and <code>jesd204_rx_controlout</code>.</li> <li>• Added <b>CONTROL_BUS_WIDTH</b> parameter and description for the assembler and deassembler.</li> <li>• Added information on how to run the Tcl script using the Quartus II software before compiling the design example.</li> <li>• Updated the section on <a href="#">Debugging JESD204B Link Using System Console</a> on page 162 with verification information for TX PHY-link layer interface, TX link layer, and TX transport layer operations.</li> </ul>
June 2014	2014.06.30	<ul style="list-style-type: none"> <li>• Updated <a href="#">Figure 2-1</a> to show a typical system application.</li> <li>• Updated the list of core key features.</li> <li>• Updated the Performance and Resource utilization values.</li> <li>• Updated the Getting Started chapter to reflect the new IP Catalog and parameter editor.</li> </ul>

*continued...*



Date	Version	Changes
		<ul style="list-style-type: none"><li>• Added the following new sections to further describe the JESD204B IP core features:<ul style="list-style-type: none"><li>– Channel Bonding</li><li>– Datapath Modes</li><li>– IP Core Variation</li><li>– JESD204B IP Core Testbench</li><li>– JESD204B IP Core Design Considerations</li><li>– TX Data Link Layer</li><li>– TX PHY Layer</li><li>– RX Data Link Layer</li><li>– RX PHY Layer</li><li>– Operation</li><li>– Dynamic Reconfiguration</li><li>– JESD204B IP Core Debug Guidelines</li></ul></li><li>• Updated the Clocking scheme section.</li><li>• Added new transceiver signals that is supported in Intel Arria 10 devices.</li><li>• Updated the Transport Layer section.</li><li>• Added run-time reconfiguration parameter values in the System Parameters section.</li><li>• Updated the file directory names.</li></ul>
November 2013	2013.11.04	Initial release.



Компания «Океан Электроники» предлагает заключение долгосрочных отношений при поставках импортных электронных компонентов на взаимовыгодных условиях!

Наши преимущества:

- Поставка оригинальных импортных электронных компонентов напрямую с производств Америки, Европы и Азии, а так же с крупнейших складов мира;
- Широкая линейка поставок активных и пассивных импортных электронных компонентов (более 30 млн. наименований);
- Поставка сложных, дефицитных, либо снятых с производства позиций;
- Оперативные сроки поставки под заказ (от 5 рабочих дней);
- Экспресс доставка в любую точку России;
- Помощь Конструкторского Отдела и консультации квалифицированных инженеров;
- Техническая поддержка проекта, помощь в подборе аналогов, поставка прототипов;
- Поставка электронных компонентов под контролем ВП;
- Система менеджмента качества сертифицирована по Международному стандарту ISO 9001;
- При необходимости вся продукция военного и аэрокосмического назначения проходит испытания и сертификацию в лаборатории (по согласованию с заказчиком);
- Поставка специализированных компонентов военного и аэрокосмического уровня качества (Xilinx, Altera, Analog Devices, Intersil, Interpoint, Microsemi, Actel, Aeroflex, Peregrine, VPT, Syfer, Eurofarad, Texas Instruments, MS Kennedy, Miteq, Cobham, E2V, MA-COM, Hittite, Mini-Circuits, General Dynamics и др.);

Компания «Океан Электроники» является официальным дистрибьютором и эксклюзивным представителем в России одного из крупнейших производителей разъемов военного и аэрокосмического назначения «JONHON», а так же официальным дистрибьютором и эксклюзивным представителем в России производителя высокотехнологичных и надежных решений для передачи СВЧ сигналов «FORSTAR».



## JONHON

«JONHON» (основан в 1970 г.)

Разъемы специального, военного и аэрокосмического назначения:

(Применяются в военной, авиационной, аэрокосмической, морской, железнодорожной, горно- и нефтедобывающей отраслях промышленности)

«FORSTAR» (основан в 1998 г.)

ВЧ соединители, коаксиальные кабели, кабельные сборки и микроволновые компоненты:

(Применяются в телекоммуникациях гражданского и специального назначения, в средствах связи, РЛС, а так же военной, авиационной и аэрокосмической отраслях промышленности).



Телефон: 8 (812) 309-75-97 (многоканальный)

Факс: 8 (812) 320-03-32

Электронная почта: [ocean@oceanchips.ru](mailto:ocean@oceanchips.ru)

Web: <http://oceanchips.ru/>

Адрес: 198099, г. Санкт-Петербург, ул. Калинина, д. 2, корп. 4, лит. А