

FUJITSU Component Thermal Printer FTP-63GMCL153/453 series

Fujitsu 3" high speed (up to 200mm/s) thermal printer mechanism with cutter option

Overview

The FTP-63GMCL series thermal printer driven by 24VDC provides high speed printing (up to 200mm/s) for 3-inch wide paper.

The series is suitable for a variety of applications, such as POS/ECR, kiosk terminals, ticket machines, label printers, banking machines, measuring devices, medical equipment, etc.

Features

- **High-speed printing**
It can print up to 200mm/s (1600 dotlines/s) maximum by using Fujitsu Components' unique head drive control
- **Rear paper insertion mechanism with lock type**
Fujitsu Components' unique platen release mechanism allows for a straight paper path and easy head maintenance
- **Auto Cutter**
Optional ultra-low profile auto cutter (full/partial cut) comes mounted from the factory.
- **Multi-feature diecast frame**
The rugged die-cast frame provides excellent ESD performance, is shock/vibration resistant and the heat-sink allows for continuous printing
- **Compact size**
Depth: 20.4mm, width: 96.2mm, height: 36.3mm (FTP-63GMCL153)
Depth: 32.4mm, width: 100.5mm, height: 45.6mm (FTP-63GMCL453)
- **High resolution**
8 dots/mm head provides clear print
- **Paper width**
80mm
- **RoHS compliant**
- **UL recognized. File number E171434**

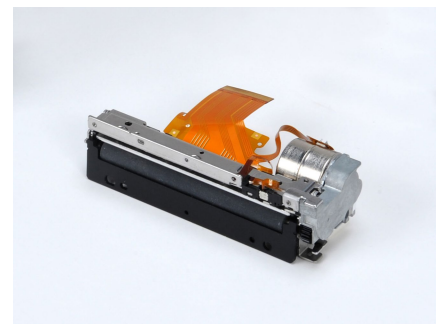

FTP-63GMCL153

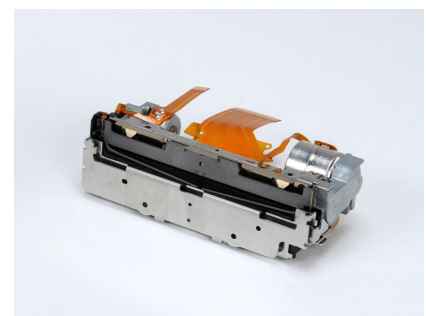

FTP-63GMCL453

■ Part numbers

Item		Part Numbers
Printer mechanism	Back insertion	FTP-63GMCL153
Mechanism with cutter	Rear insertion	FTP-63GMCL453
LSI for driving		Under development
Interface board	Serial (RS232C/USB)	FTP-62GDSL001#01 (Japanese font)
	Serial (RS232C/USB)	FTP-62GDSL001#02 (Traditional Chinese font)
Interface cable	Serial	FTP-62GY302
	USB	FTP-62GY301
Power supply cable	Logic, head, motor	FTP-62GY601

■ Specifications

Item		Specifications	
Part number		FTP-63GMCL153	FTP-63GMCL453
Printing method		Thermal sensitive line dot method	
Dot structure		576 dots/lines	
Dot pitch (horizontal)		0.125mm (8 dots/mm) - Dot density	
Dot pitch (vertical)		0.125mm (8 dots/mm) - Line feed pitch	
Effective printing area		72mm	
Number of columns		ANK 48 columns/line (12 x 24 x dot font), OCD 24 columns (24 x 40)	
Paper width		80mm +0/-1	
Paper thickness		60-150 μ m*1	60-100 μ m*1
Cutting type		---	Full or partial
Printing speed		200mm/s (1600 dot lines/s)	
Character types	Alphanumeric KANA	159 types	
	International and special	195 types	
	OCRI	103 types	
	OCRIII	23 types	
	OCRIV	103 types	
	Extended numeric	12 types	
	JIS KANJI level 1, 2, non-Kanji	JIS KANJI: approx. 6800	
Character dimensions (W x H), number of characters	Traditional Chinese	13, 503	
		8 x 16 dots, 72 columns, ANK	24 x 40 dots, 24 columns, OCRI
		12 x 24 dots, 48 columns, ANK	24 x 48 dots, 24 columns, OCRII
		16 x 16 dots, 36 columns, ANK	36 x 60 dots, 16 columns, OCRIV
	24 x 24 dots, 24 columns, ANK	24 x 48 dots, 24 columns, extended numeric	

*1: there may be exceptions

Item	Specifications		
Part number	FTP-63GMCL153	FTP-63GMCL453	
Power	For head	24VDC \pm 10% 3A (24V, 1500 Ω , +25°C, concurrent applied dot number: 192 dots)	
	For printer motor	24VDC \pm 10% 0.6A maximum	
	For logic	3.3 or 5 VDC \pm 5% 0.1A maximum	
Dimensions (WxDxH)	Printer mechanism	96.2 x 20.4 x 36.3mm	---
	Printer mechanism w/ cutter	---	100.5 x 32.6 x 45.6mm
	Interface board (DCL/DSL)	70 x 35mm	
Weight	Printer mechanism	79g	---
	Printer mechanism w/ cutter	---	155g
	Interface board (DCL/DSL)	15g	
Expected life	Head	Pulse durability: 100 million pulse/dot (using Fujitsu Components' standard driving method) Wear resistance: 100km (at 12.5% print ratio)	
	Cutter	---	500,000 cuts min.
Environmental conditions	Operating temperature	+5°C to +40°C (guarantee)	
	Operating humidity	20 to 85% RH (no condensation)	
	Storage temperature	-20°C to +60°C (excluding paper)	
	Storage humidity	5 to 95% RH (no condensation)	
Detection functions	Head temperature	By thermistor	
	Paper out/Mark detect	By photointerrupter	
	Head release	By slide switch	
Recommended thermal sensitive paper	High sensitive paper	TF50KS-E45 (Nippon paper)	
	Standard paper	TF-60KS-E (Nippon paper)	
		PD150R (Oji paper)	
	Medium term paper	TF-60KS-F1 (Nippon paper)	
PD170R (Oji paper) P220VBB-1 (Mitsubishi paper)			
Long term paper	PD160R-N (Oji paper)		

■ Dimensions

- Printer mechanism 3-inch

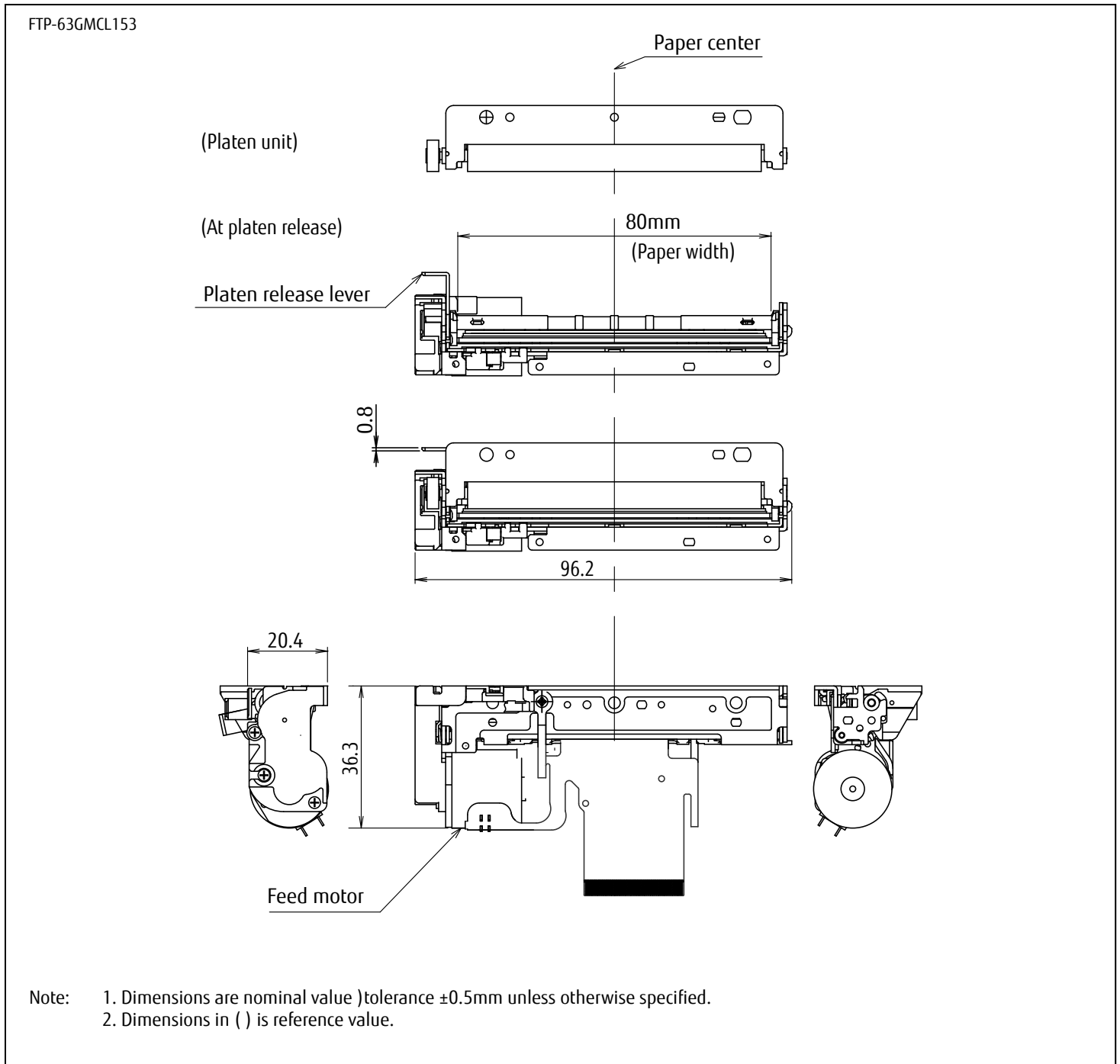

- Printer mechanism / cutter 3-inch

FTP-63GMCL453

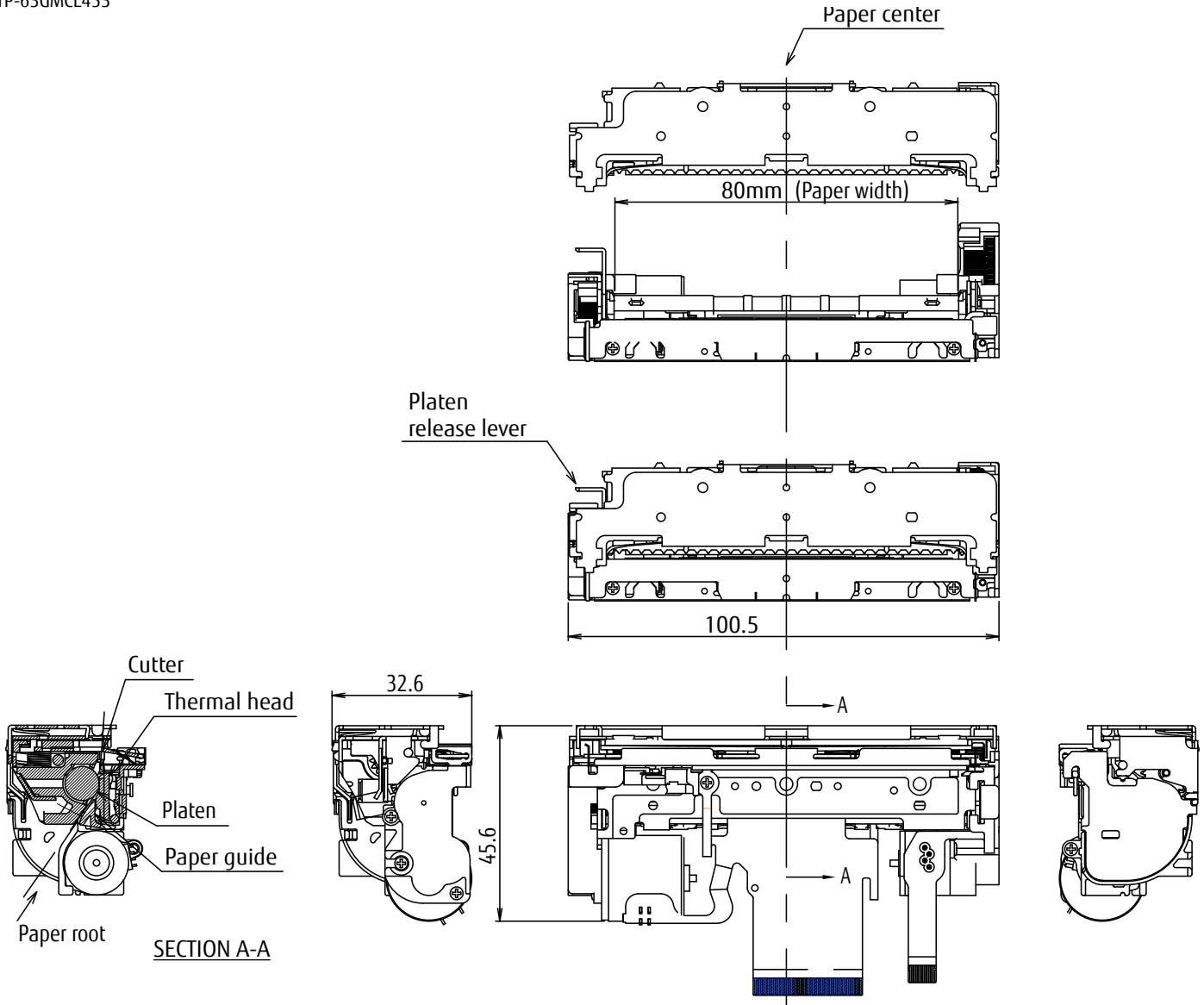

Note: 1. Dimensions are nominal value)tolerance $\pm 0.5\text{mm}$ unless otherwise specified.
2. Dimensions in () is reference value.

■ Connector pin assignments of printer mechanism (FPC)
Recommended connector of head FPC: 54104-5031 (Molex) or equivalent

No	Signal	Content	I/O
1	VSEN	Paper sensor power	IN
2	PHK	Cathode for photo interrupter	OUT
3	PHE	Emitter for photo interrupter	OUT
4	N.C.	Not connected	-
5	VH	Head drive power	IN
6	VH	Head drive power	IN
7	VH	Head drive power	IN
8	VH	Head drive power	IN
9	DI	Data in	IN
10	/STB3	/Strobe3	IN
11	/STB4	/Strobe4	IN
12	VDD	Logic power	IN
13	GND	Head ground	-
14	GND	Head ground	-
15	GND	Head ground	-
16	GND	Head ground	-
17	GND	Head ground	-
18	GND	Head ground	-
19	GND	Head ground	-
20	GND	Head ground	-
21	TM	Thermistor	OUT
22	/STB1	/Strobe1	IN
23	/STB2	/Strobe2	IN
24	/LAT	/Data latch	IN
25	CLK	Clock	IN
26	VH	Head drive power	IN
27	VH	Head drive power	IN
28	VH	Head drive power	IN
29	VH	Head drive power	IN
30	N.C.	Not connected	-
31	SW	Platen switch release	OUT
32	SW	Platen switch release	OUT
33	MT_/A	Excitation signal /A	SINK/SOURCE
34	MT_/A	Excitation signal /A	SINK/SOURCE
35	MT_A	Excitation signal A	SINK/SOURCE
36	MT_A	Excitation signal A	SINK/SOURCE
37	MT_/B	Excitation signal /B	SINK/SOURCE
38	MT_/B	Excitation signal /B	SINK/SOURCE
39	MT_B	Excitation signal B	SINK/SOURCE
40	MT_B	Excitation signal B	SINK/SOURCE

■ Connector pin assignments of cutter (FPC)

Recommended connector of cutter motor FPC: 52745-1297 (Molex) or equivalent

No	Signal	Content	I/O
1	MT_B	Excitation signal B	SINK/SOURCE
2	MT_B	Excitation signal B	SINK/SOURCE
3	MT_/B	Excitation signal /B	SINK/SOURCE
4	MT_/B	Excitation signal /B	SINK/SOURCE
5	MT_A	Excitation signal A	SINK/SOURCE
6	MT_A	Excitation signal A	SINK/SOURCE
7	MT_/A	Excitation signal /A	SINK/SOURCE
8	MT_/A	Excitation signal /A	SINK/SOURCE
9	N.C.	Not connected	-
10	VSEN	Paper sensor power	IN
11	PHE	Emitter for photo interrupter	OUT
12	PHK	Cathode for photo interrupter	OUT

Contact

Japan

FUJITSU COMPONENT LIMITED
Shinagawa Seaside Park Tower
12-4, Higashi-shinagawa 4-chome,
Tokyo 140 0002, Japan
Tel: (81-3) 3450-1682
Fax: (81-3) 3474-2385
Email: fcl-contact@cs.jp.fujitsu.com
Web: www.fujitsu.com/jp/group/fcl/en/

Europe

FUJITSU COMPONENTS EUROPE B.V.
Diamantlaan 25
2132 WV Hoofddorp, The Netherlands
Tel: (31-23) 5560910
Fax: (31-23) 5560950
Email: info@fceu.fujitsu.com
Web: www.fujitsu.com/uk/products/
devices/components/

China

FUJITSU ELECTRONIC COMPONENTS
(SHANGHAI) CO., LTD.
Unit 4306, InterContinental Center
100 Yu Tong Road, Shanghai 200070, China
Tel: (86 21) 3253 0998 / Fax: (86 21) 3253 0997
Email: fcal@sg.fujitsu.com
www.fujitsu.com/sg/products/devices/
components/

Korea

FUJITSU COMPONENTS KOREA, LTD.
Alpha Tower #403,
645 Sampyeong-dong,
Bundang-gu, Seongnam-si,
Gyeonggi-do, 13524 Korea
Tel: (82 31) 708-7108
Fax: (82 31) 709-7108
Email: fcal@sg.fujitsu.com
www.fujitsu.com/sg/products/
devices/components/

North and South America

FUJITSU COMPONENTS AMERICA, INC.
2290 North First Street, Suite 212
San Jose, CA 95131 U.S.A.
Tel: (1-408) 745-4900
Fax: (1-408) 745-4970
Email: components@us.fujitsu.com
Web: http://us.fujitsu.com/components/

Asia Pacific

FUJITSU COMPONENTS ASIA, Ltd.
102E Pasir Panjang Road
#01-01 Citilink Warehouse Complex,
Singapore 118529
Tel: (65) 6375-8560 / Fax: (65) 6273-3021
Email: fcal@sg.fujitsu.com
www.fujitsu.com/sg/products/devices/
components/

Hong Kong

FUJITSU COMPONENTS HONG KONG Co., Ltd.
Room 06, 28/F, Greenfield Tower, Concordia
Plaza, No.1 Science Museum Road,
Tsim Sha Tsui East, Kowloon, Hong Kong
Tel: (852) 2881 8495 Fax: (852) 2894 9512
Email: fcal@sg.fujitsu.com
www.fujitsu.com/sg/products/devices/
components/

Copyright

All trademarks or registered trademarks are the property of their respective owners. Fujitsu Components America or its affiliates do not warrant that the content of datasheet is error free. In a continuing effort to improve our products Fujitsu Components America, Inc. or its affiliates reserve the right to change specifications/datasheets without prior notice. Copyright ©2018 Fujitsu Components America, Inc. All rights reserved. Revised November 8, 2018

Компания «Океан Электроники» предлагает заключение долгосрочных отношений при поставках импортных электронных компонентов на взаимовыгодных условиях!

Наши преимущества:

- Поставка оригинальных импортных электронных компонентов напрямую с производств Америки, Европы и Азии, а так же с крупнейших складов мира;
- Широкая линейка поставок активных и пассивных импортных электронных компонентов (более 30 млн. наименований);
- Поставка сложных, дефицитных, либо снятых с производства позиций;
- Оперативные сроки поставки под заказ (от 5 рабочих дней);
- Экспресс доставка в любую точку России;
- Помощь Конструкторского Отдела и консультации квалифицированных инженеров;
- Техническая поддержка проекта, помощь в подборе аналогов, поставка прототипов;
- Поставка электронных компонентов под контролем ВП;
- Система менеджмента качества сертифицирована по Международному стандарту ISO 9001;
- При необходимости вся продукция военного и аэрокосмического назначения проходит испытания и сертификацию в лаборатории (по согласованию с заказчиком);
- Поставка специализированных компонентов военного и аэрокосмического уровня качества (Xilinx, Altera, Analog Devices, Intersil, Interpoint, Microsemi, Actel, Aeroflex, Peregrine, VPT, Syfer, Eurofarad, Texas Instruments, MS Kennedy, Miteq, Cobham, E2V, MA-COM, Hittite, Mini-Circuits, General Dynamics и др.);

Компания «Океан Электроники» является официальным дистрибьютором и эксклюзивным представителем в России одного из крупнейших производителей разъемов военного и аэрокосмического назначения «JONHON», а так же официальным дистрибьютором и эксклюзивным представителем в России производителя высокотехнологичных и надежных решений для передачи СВЧ сигналов «FORSTAR».



JONHON

«JONHON» (основан в 1970 г.)

Разъемы специального, военного и аэрокосмического назначения:

(Применяются в военной, авиационной, аэрокосмической, морской, железнодорожной, горно- и нефтедобывающей отраслях промышленности)

«FORSTAR» (основан в 1998 г.)

ВЧ соединители, коаксиальные кабели,
кабельные сборки и микроволновые компоненты:

(Применяются в телекоммуникациях гражданского и специального назначения, в средствах связи, РЛС, а так же военной, авиационной и аэрокосмической отраслях промышленности).



Телефон: 8 (812) 309-75-97 (многоканальный)

Факс: 8 (812) 320-03-32

Электронная почта: ocean@oceanchips.ru

Web: <http://oceanchips.ru/>

Адрес: 198099, г. Санкт-Петербург, ул. Калинина, д. 2, корп. 4, лит. А