

DESCRIPTION

The MP2225 is a high-frequency, synchronous, rectified, step-down, switch-mode converter with built-in power MOSFETs. It offers a very compact solution to achieve a 5A output current with excellent load and line regulation over a wide input supply range. The MP2225 has synchronous mode operation for higher efficiency over the output current load range.

Current-mode operation provides fast transient response and eases loop stabilization.

Full protection features include over-current protection and thermal shut down.

The MP2225 requires a minimal number of readily-available standard external components, and is available in a space-saving 8-pin TSOT23 package.

FEATURES

- Wide 4.5V-to-18V Operating Input Range
- Adjustable Output Voltage as low as 0.6V
- Low 47mΩ/18mΩ $R_{DS(ON)}$ of Internal Power MOSFETs
- High Efficiency up to 97%
- Fixed 500kHz Switching Frequency
- Synchronizes from a 200kHz-to-2MHz External Clock
- 2.4ms Internal Soft-Start Time
- 1% Reference Accuracy at Room Temperature
- Internal Power-save Mode
- OCP with hiccup mode
- Available in 8-pin TSOT23

APPLICATIONS

- Flat-Panel Television and Monitors
- Notebook Systems and I/O Power
- Digital Set-Top Boxes
- Distributed Power Systems

All MPS parts are lead-free and adhere to the RoHS directive. For MPS green status, please visit MPS website under Products, Quality Assurance page. "MPS" and "The Future of Analog IC Technology" are registered trademarks of Monolithic Power Systems, Inc.

TYPICAL APPLICATION

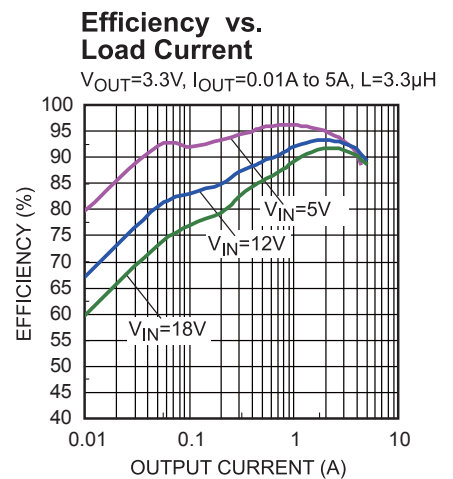
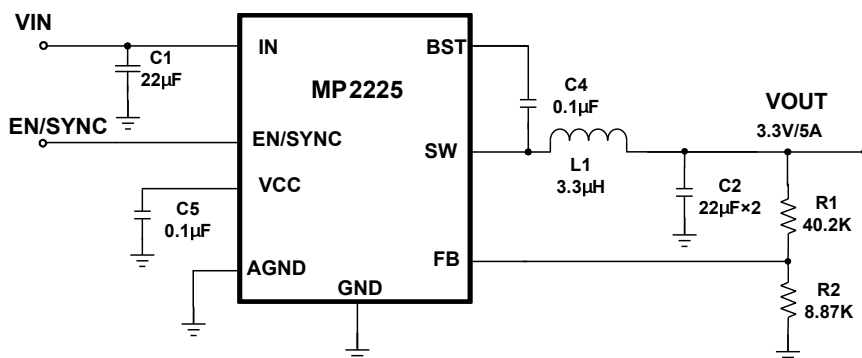

ORDERING INFORMATION

Part Number*	Package	Top Marking
MP2225GJ	TSOT23-8	See Below

For Tape & Reel, add suffix –Z (e.g. MP2225GJ–Z);

TOP MARKING

| AFRY

AFR: product code of MP2225GJ;
Y: year code;

PACKAGE REFERENCE

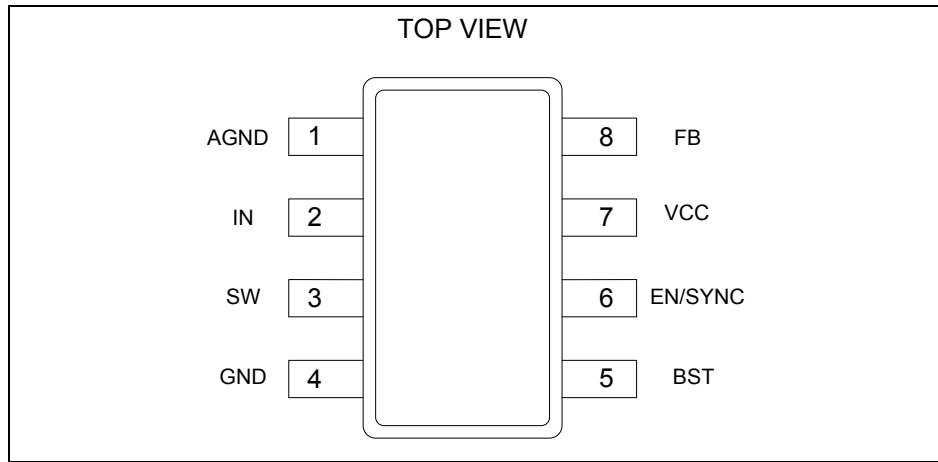

ABSOLUTE MAXIMUM RATINGS ⁽¹⁾

V_{IN}	-0.3V to 20V
V_{SW}	-0.3V (-5V for <10ns) to $V_{IN}+0.3V$ (23V for <10ns)
V_{BST}	$V_{SW}+5.5V$
All Other Pins.....	-0.3V to 5.5V ⁽²⁾
Continuous Power Dissipation ($T_A = +25^\circ C$) ⁽³⁾	
TSOT23-8.....	1.25W
Junction Temperature.....	150°C
Lead Temperature.....	260°C
Storage Temperature.....	-65°C to 150°C

Recommended Operating Conditions ⁽⁴⁾

Supply Voltage V_{IN}	4.5V to 18V
Output Voltage V_{OUT}	0.6V to $V_{IN} \cdot D_{MAX}$
Operating Junction Temp. (T_J).....	-40°C to +125°C

Thermal Resistance ⁽⁵⁾	θ_{JA}	θ_{JC}	
TSOT23-8.....	100	55...	°C/W

Notes:

- 1) Exceeding these ratings may damage the device.
- 2) About the details of EN pin's ABS MAX rating, please refer to Page 12, Enable/SYNC control section.
- 3) The maximum allowable power dissipation is a function of the maximum junction temperature T_J (MAX), the junction-to-ambient thermal resistance θ_{JA} , and the ambient temperature T_A . The maximum allowable continuous power dissipation at any ambient temperature is calculated by P_D (MAX) = $(T_J$ (MAX)- T_A)/ θ_{JA} . Exceeding the maximum allowable power dissipation will cause excessive die temperature, and the regulator will go into thermal shutdown. Internal thermal shutdown circuitry protects the device from permanent damage.
- 4) The device is not guaranteed to function outside of its operating conditions.
- 5) Measured on JESD51-7, 4-layer PCB.

ELECTRICAL CHARACTERISTICS

$V_{IN} = 12V$, $T_J = -40^{\circ}C$ to $+125^{\circ}C$ ⁽⁶⁾, Typical value is tested at $T_J = +25^{\circ}C$, unless otherwise noted.

Parameter	Symbol	Condition	Min	Typ	Max	Units
Supply Current (Shutdown)	I_{IN}	$V_{EN} = 0V, T_J = 25^{\circ}C$			1	μA
Supply Current (Shutdown)	I_{IN}	$V_{EN} = 0V$			3	μA
Supply Current (Quiescent)	I_Q	$V_{EN} = 2V, V_{FB} = 0.7V$		320	400	μA
HS Switch-On Resistance	HS_{RDS-ON}	$V_{BST-SW} = 5V$		47		m Ω
LS Switch-On Resistance	LS_{RDS-ON}	$V_{CC} = 5V$		18		m Ω
Switch Leakage	SW_{LKG}	$V_{EN} = 0V, V_{SW} = 12V, T_J = 25^{\circ}C$			1	μA
Current Limit ⁽⁷⁾	I_{LIMIT}	Under 40% Duty Cycle	6.5	9		A
Oscillator Frequency	F_{SW}	$V_{FB} = 0.48V$	380	500	580	kHz
Fold-Back Frequency	F_{FB}	$V_{FB} < 300mV$		0.56		F_{SW}
Maximum Duty Cycle	D_{MAX}	$V_{FB} = 500mV$	90	95		%
Minimum On Time ⁽⁸⁾	T_{ON_MIN}			50		ns
Sync Frequency Range	F_{SYNC}		0.2		2	MHz
Feedback Voltage	V_{FB}	$T_J = 25^{\circ}C$	594	600	606	mV
Feedback Voltage	V_{FB}		591	600	609	mV
Feedback Current	I_{FB}	$V_{FB} = 620mV$		10	50	nA
EN Rising Threshold	V_{EN_RISING}		1.15	1.4	1.65	V
EN Hysteresis	V_{EN_HYS}			160		mV
EN Input Current	I_{EN}	$V_{EN} = 2V$		1.85		μA
		$V_{EN} = 0$		0		μA
EN Turn-Off Delay	EN_{td-off}		5	10		μs
VIN Under-Voltage Lockout Threshold-Rising	$INUV_{Vth}$		3.85	4.1	4.35	V
VIN Under-Voltage Lockout Threshold-Hysteresis	$INUV_{HYS}$			735		mV
Soft-Start Time	T_{SS}	10% to 90% Output Voltage		2.4		ms
Thermal Shutdown ⁽⁸⁾	T_{SD}			150		$^{\circ}C$
Thermal Hysteresis ⁽⁸⁾	T_{SD_HYS}			20		$^{\circ}C$

Notes:

- 6) Not tested in production. Guaranteed by over-temperature correlation.
 7) Guaranteed by engineering sample characterization.
 8) Guaranteed by design.

TYPICAL PERFORMANCE CHARACTERISTICS

Performance waveforms are tested on the evaluation board described in the Design Example section.

$V_{IN} = 12V$, $V_{OUT} = 3.3V$, $T_A = 25^\circ C$, unless otherwise noted.

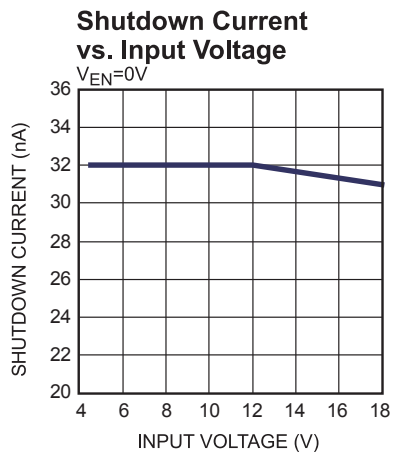
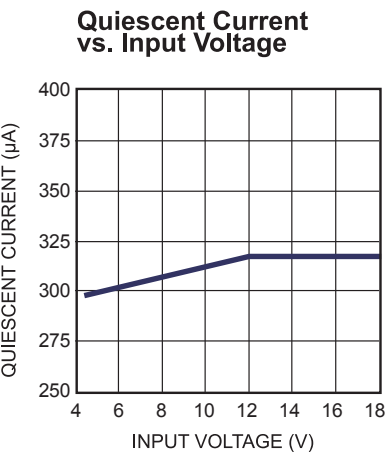
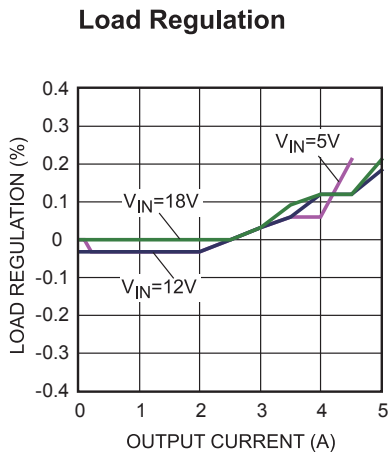
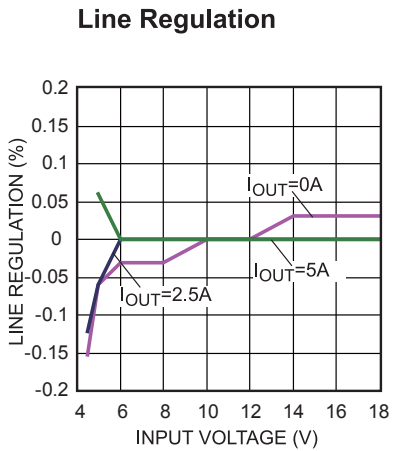
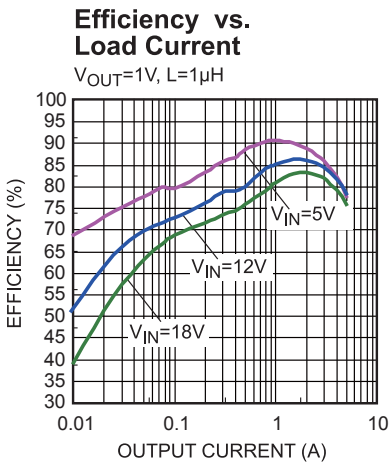
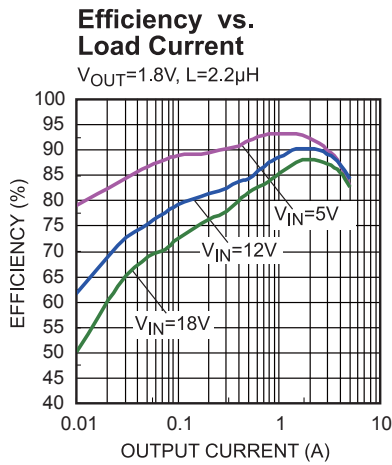
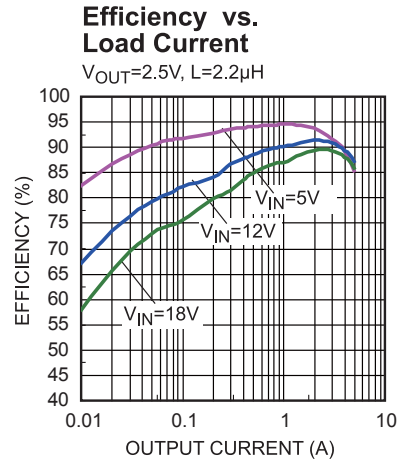
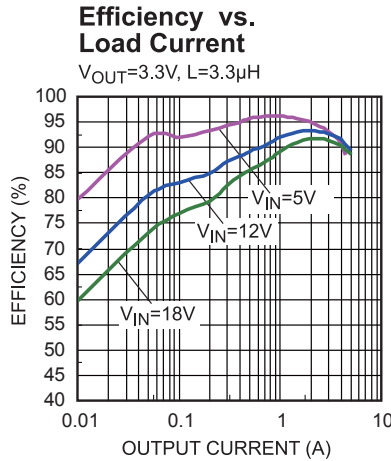
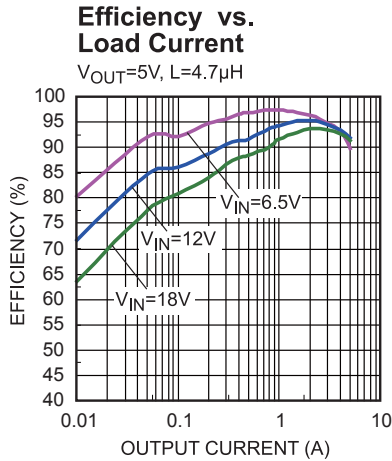

TYPICAL PERFORMANCE CHARACTERISTICS *(continued)*

Performance waveforms are tested on the evaluation board described in the Design Example section.

$V_{IN} = 12V$, $V_{OUT} = 3.3V$, $T_A = 25^{\circ}C$, unless otherwise noted.

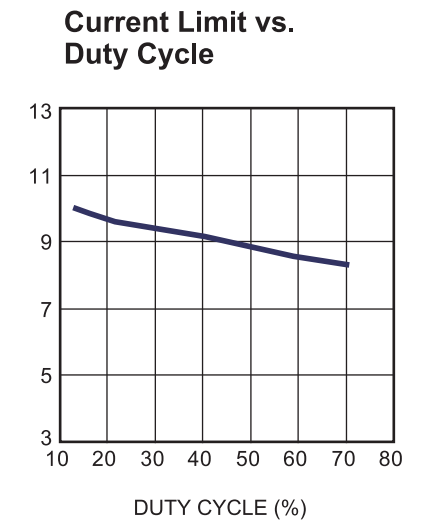
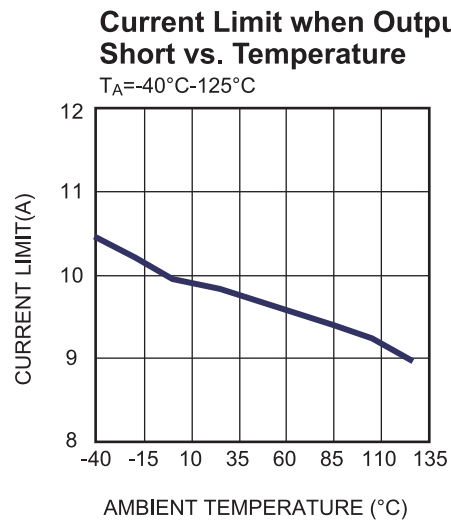
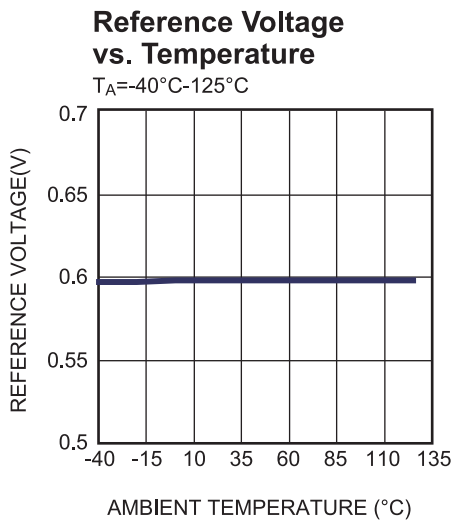
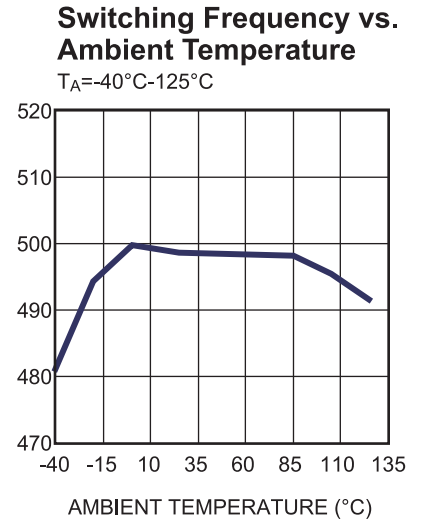
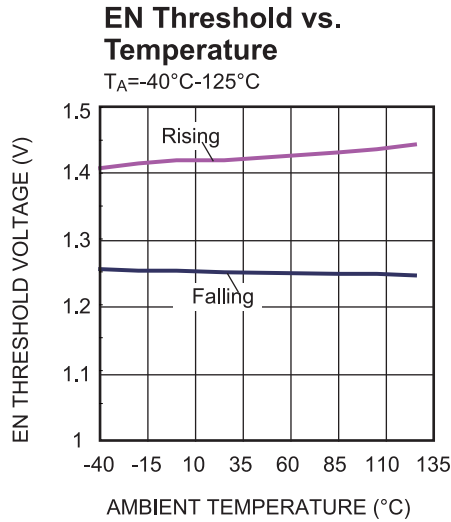
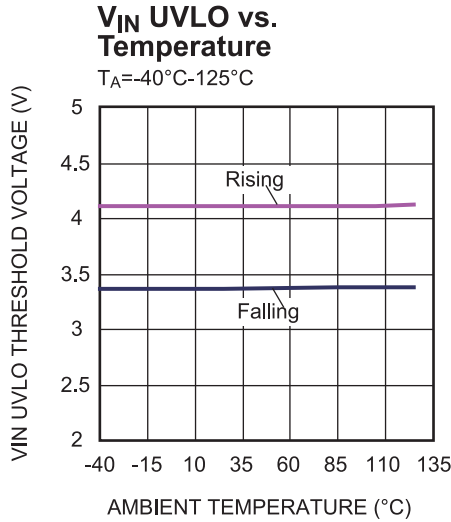

TYPICAL PERFORMANCE CHARACTERISTICS *(continued)*

Performance waveforms are tested on the evaluation board described in the Design Example section.

$V_{IN} = 12V$, $V_{OUT} = 3.3V$, $T_A = 25^\circ C$, unless otherwise noted.

Output Current Derating vs. Output Voltage

$T_{case_rise}=45^\circ C$,
on 4-Layered Board in Size 6.5cmX6.5cm

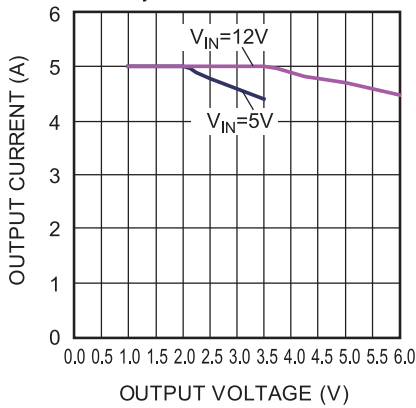

Output Current Derating vs. Output Voltage

$T_{case_rise}=45^\circ C$,
on 2-Layered Board in Size 6.5cmX6.5cm

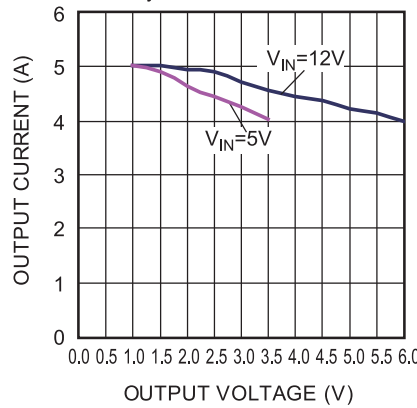

Output Current Derating vs. Ambient Temperature

$V_{IN}=5V$, $T_J=125^\circ C$
on 4-Layered Board in Size 6.5cmX6.5cm

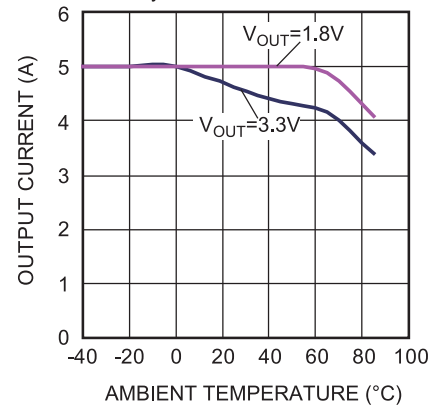

Output Current Derating vs. Ambient Temperature

$V_{IN}=12V$, $T_J=125^\circ C$
on 4-Layered Board in Size 6.5cmX6.5cm

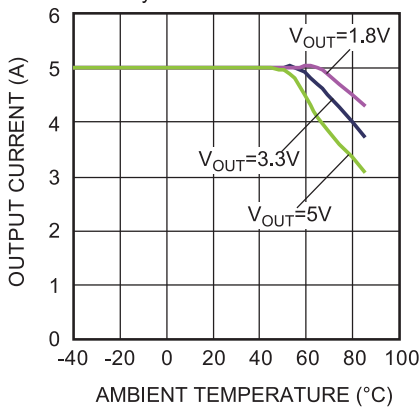

Output Current Derating vs. Ambient Temperature

$V_{IN}=5V$, $T_J=125^\circ C$
on 2-Layered Board in Size 6.5cmX6.5cm

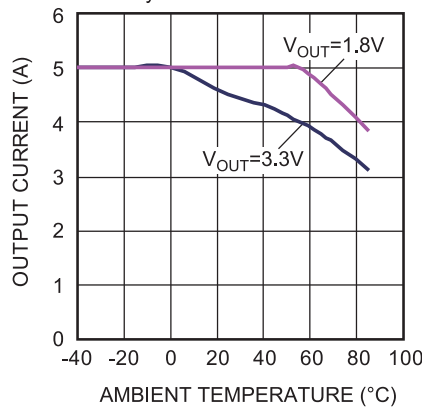

Output Current Derating vs. Ambient Temperature

$V_{IN}=12V$, $T_J=125^\circ C$
on 2-Layered Board in Size 6.5cmX6.5cm

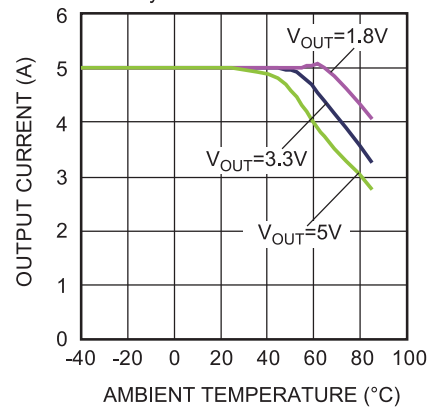

TYPICAL PERFORMANCE CHARACTERISTICS (continued)

Performance waveforms are tested on the evaluation board described in the Design Example section.

$V_{IN} = 12V$, $V_{OUT} = 3.3V$, $T_A = 25^\circ C$, unless otherwise noted.

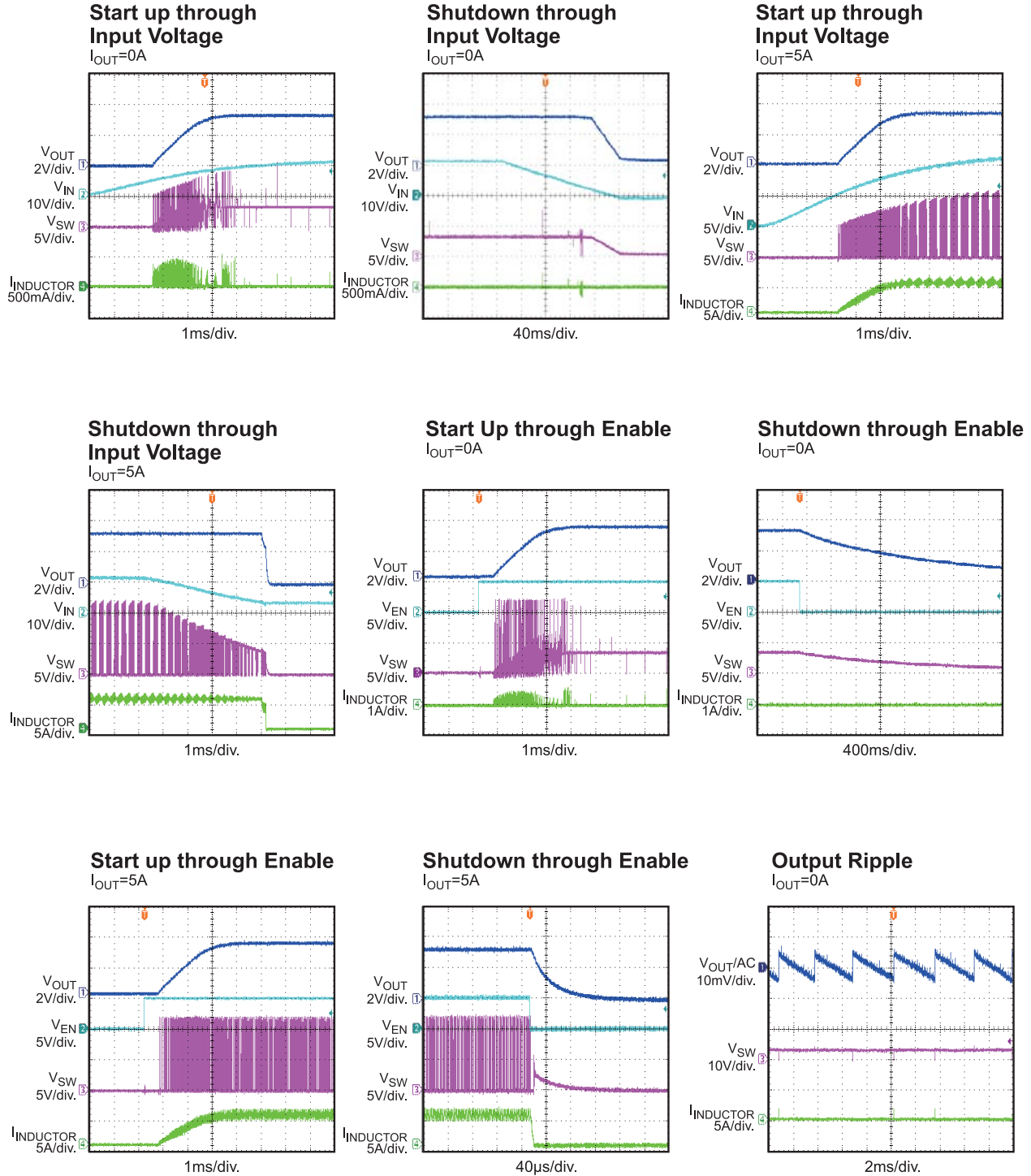

TYPICAL PERFORMANCE CHARACTERISTICS (continued)

Performance waveforms are tested on the evaluation board described in the Design Example section.

$V_{IN} = 12V$, $V_{OUT} = 3.3V$, $T_A = 25^{\circ}C$, unless otherwise noted.

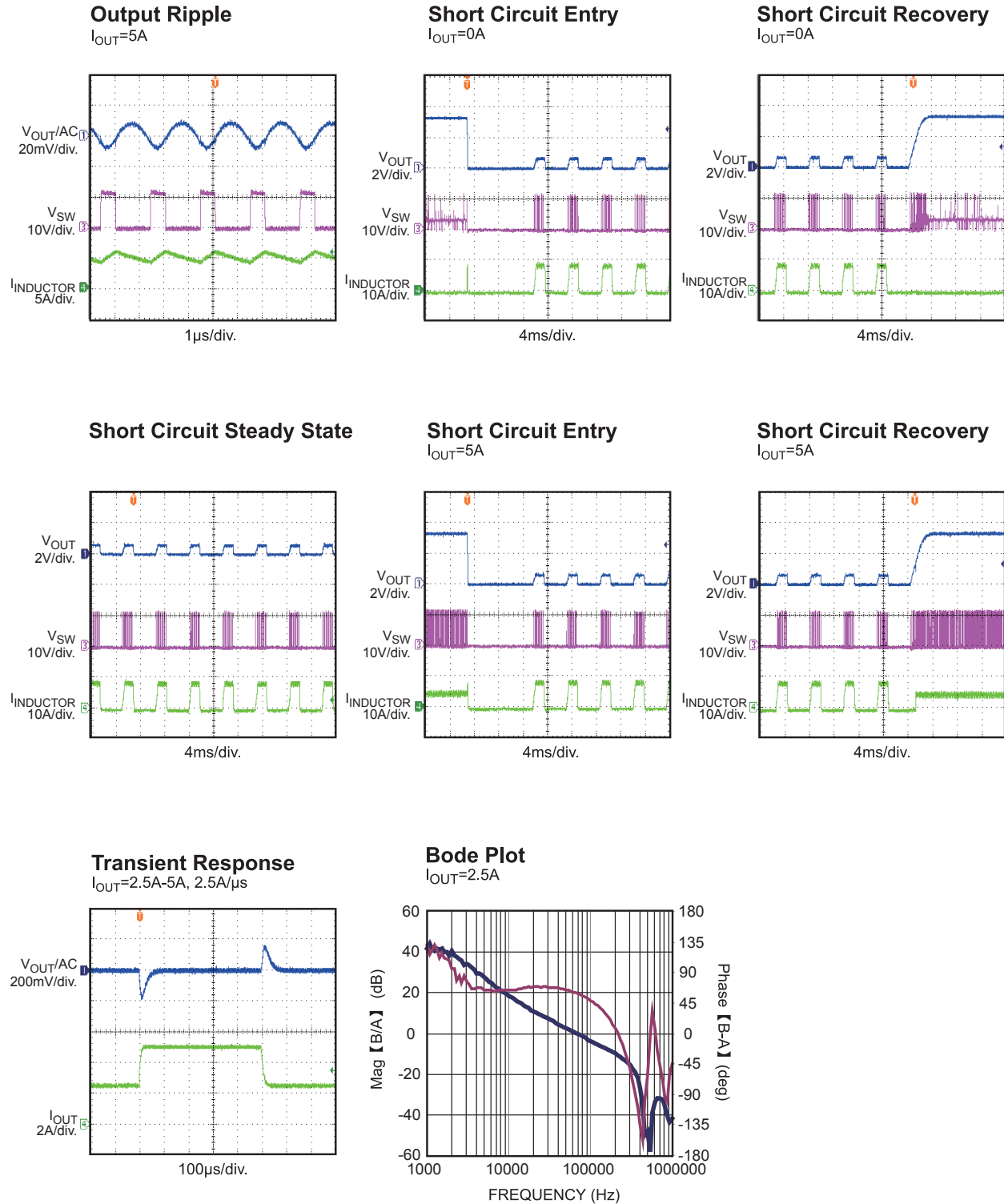

PIN FUNCTIONS

Pin #	Name	Description
1	AGND	Analog Ground. Connect it to GND.
2	IN	Supply Voltage. The MP2225 operates from a 4.5V-to-18V input rail. Requires C1 to decouple the input rail. Connect using a wide PCB trace.
3	SW	Switch Output. Connect using a wide PCB trace.
4	GND	Power Ground. Requires special consideration during PCB layout. Connect to GND with copper traces and vias.
5	BST	Bootstrap. Requires a capacitor between SW and BST pins to form a floating supply across the high-side switch driver.
6	EN/SYNC	EN high to enable the MP2225. Can apply an external clock to the EN pin to change the switching frequency.
7	VCC	Bias Supply. Decouple with a 0.1 μ F-to-0.22 μ F capacitor.
8	FB	Feedback. Connect to the tap of an external resistor divider from the output to GND to set the output voltage. The frequency fold-back comparator lowers the oscillator frequency when the FB voltage is below 480mV to prevent current-limit run-away during a short-circuit fault condition.

FUNCTIONAL BLOCK DIAGRAM

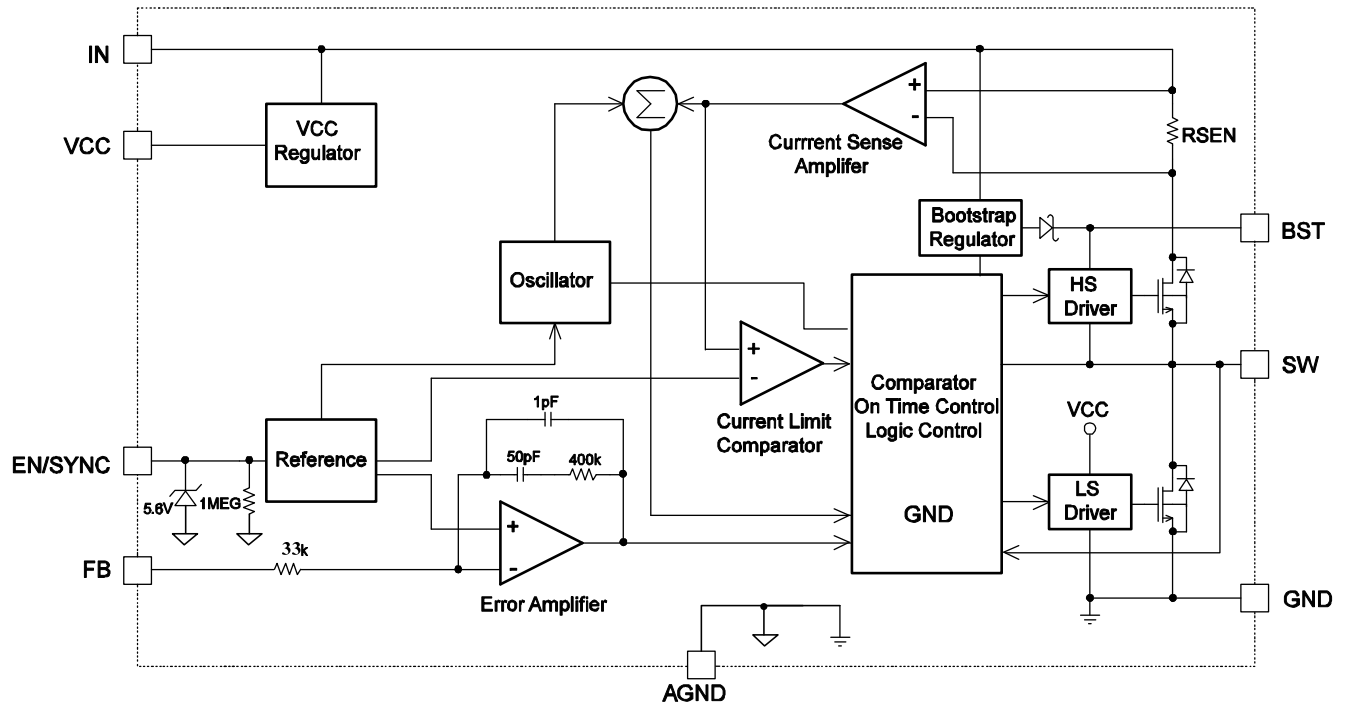

Figure 1: Functional Block Diagram

OPERATION

The MP2225 is a high-frequency, synchronous, rectified, step-down, switch-mode converter with built-in power MOSFETs. It offers a very compact solution to achieve 5A output current with excellent load and line regulation over a wide input supply range.

The MP2225 operates in a fixed-frequency, peak-current-control mode to regulate the output voltage. An internal clock initiates a PWM cycle. The integrated high-side power MOSFET turns on and remains in on-state until the current reaches the value set by the COMP voltage. When the power switch is off, it remains off until the next clock cycle starts. If, in 95% of one PWM period, the current in the power MOSFET does not reach the value set by the COMP value, the power MOSFET is forced to turn off.

VCC Regulator

A 5V internal regulator powers most of the internal circuitries. This regulator takes the V_{IN} input and operates in the full V_{IN} range. When V_{IN} is greater than 5.0V, the output of the regulator is in full regulation. When V_{IN} is lower than 5.0V, the output decreases, and the part requires a 0.1 μ F ceramic capacitor to decouple noise.

AAM Operation

The MP2225 has AAM (Advanced Asynchronous Modulation) which is Internal Power-save Mode for light load operation. AAM voltage V_{AAM} is internally fixed. Under the heavy load condition, the V_{COMP} is higher than V_{AAM} . When the clock goes high, the high-side power MOSFET turns on and remains on until $V_{ILsense}$ reaches the value set by the COMP voltage. The internal clock resets every time when V_{COMP} is higher than V_{AAM} .

Under the light load condition, the value of V_{COMP} becomes lower. When V_{COMP} is less than V_{AAM} and V_{FB} is less than V_{REF} , V_{COMP} ramps up until it exceeds V_{AAM} . During this time, the internal clock is blocked, thus the MP2225 skips some pulses for PFM (Pulse Frequency Modulation) mode and achieves the light load power save.

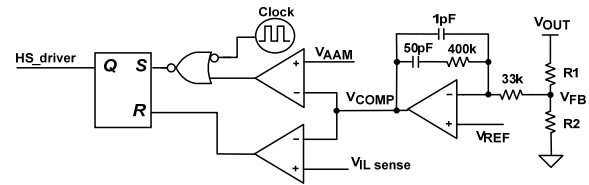

Figure 2: Simplified AAM Control Logic

Under light load condition, the inductor peak current is internally set to be fairly 800mA.

Error Amplifier

The error amplifier compares the FB pin voltage against the internal 0.6V reference (REF) and generates COMP voltage as output —COMP controls the power MOSFET current. The optimized internal compensation network minimizes the external component count and simplifies the control loop design.

Enable/SYNC Control

EN/SYNC is a digital control pin that turns the converter on and off. Drive EN/SYNC high to turn on the converter; drive it low to turn it off. An internal 1M Ω resistor from EN/SYNC to GND allows EN/SYNC to be floated to shut down the chip.

The EN/SYNC pin is clamped internally using a 5.6V series-Zener-diode as shown in Figure 3. Connecting the EN/SYNC input pin through a pullup resistor to the voltage on the V_{IN} pin limits the EN/SYNC input current to less than 100 μ A.

For example, with 12V connected to V_{in} , $R_{PULLUP} \geq (12V - 5.6V) \div 100\mu A = 64k\Omega$.

Connecting the EN/SYNC pin directly to a voltage source without any pullup resistor requires limiting the amplitude of the voltage source to $\leq 5V$ to prevent damage to the Zener diode.

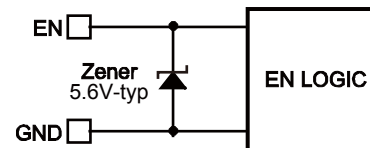

Figure 3: 5.6V Zener Diode Connection

To use external clock synchronization, connect a clock with a frequency range between 200kHz and 2MHz. The internal clock rising edge will synchronize with the external clock rising edge. Meanwhile the width of high level should be longer than 250ns, and width of low level longer than 100ns.

Under-Voltage Lockout (UVLO)

Under-voltage lockout (UVLO) protects the chip from operating at insufficient supply voltage. The MP2225 UVLO comparator monitors the output voltage of the internal regulator, VCC. The UVLO rising threshold is about 4.1V while its falling threshold is 3.4V.

Soft-Start

The soft-start prevents the converter output voltage from overshooting during startup. When the chip starts, the internal circuitry generates a soft-start voltage (SS) that ramps up from 0V to VCC. When SS is lower than REF, the error amplifier uses SS as the reference. When SS is higher than REF, the error amplifier uses REF as the reference.

The SS time is internally set to 2.4ms.

Over-Current-Protection and Hiccup

The MP2225 has a cycle-by-cycle over-current limit which can limit the inductor current in case of output over load or short circuit(SC). If the over load or SC events last for enough long time, FB voltage can drop below the Under-Voltage (UV) threshold—typically 30% of the reference. Once UV is triggered, the MP2225 enters hiccup mode to periodically restart the part. This protection mode is especially useful when the output is dead-shortened to ground. The average short circuit current is greatly reduced to alleviate thermal issues and to protect the regulator. The MP2225 exits the hiccup mode once the over-current condition is removed.

Thermal Shutdown

Thermal shutdown prevents the chip from operating at exceedingly high temperatures. When the temperature of the silicon reaches 150°C, the whole chip is shut down. When the temperature is less than its lower threshold, typically 130°C, the chip is enabled again.

Floating Driver and Bootstrap Charging

An external bootstrap capacitor powers the floating power MOSFET driver. This floating driver has its own UVLO protection. This UVLO's rising threshold is 2.6V with a hysteresis of 350mV. The bootstrap capacitor voltage is regulated internally by V_{IN} through D1, M1, C4, L1 and C2 (Figure 4). If $(V_{BST}-V_{SW})$ exceeds 5V, U1 will regulate M1 to maintain a 5V BST voltage across C4.

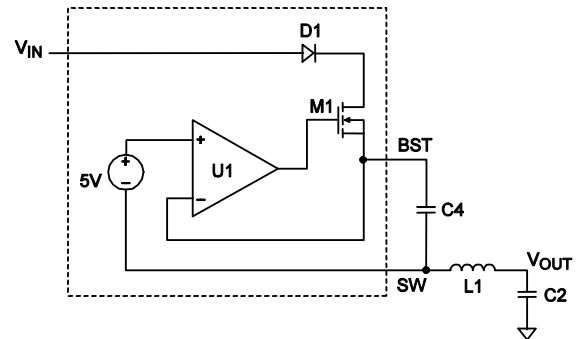

Figure 4: Internal Bootstrap Charging Circuit

Startup and Shutdown

If both V_{IN} and EN exceed their respective thresholds, the chip starts. The reference block starts up first, generating stable reference voltage, and then the internal regulator is enabled. The regulator provides a stable supply for the remaining circuitries.

Three events can shut down the chip: EN low, V_{IN} low, and thermal shutdown. In the shutdown procedure, the signaling path is first blocked to avoid any fault triggering. The COMP voltage and the internal supply rail are then pulled down. The floating driver is not subject to this shutdown command.

APPLICATION INFORMATION

Setting the Output Voltage

The external resistor divider sets the output voltage (see Typical Application on page 1). The feedback resistor R1 also sets the feedback loop bandwidth with the internal compensation capacitor. First, choose a value for R1, R2 is then given by:

$$R2 = \frac{R1}{\frac{V_{OUT}}{0.6V} - 1} \quad (1)$$

The feedback network—as shown in Figure 5—is highly recommended.

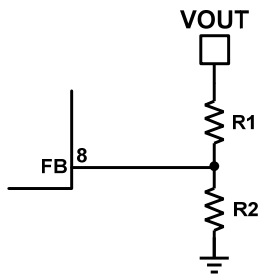

Figure 5: Feedback Network

Table 1 lists the recommended resistors and capacitors value for common output voltages.

Table 1: Component Selection for Common Output Voltages⁽⁹⁾

V _{OUT} (V)	R1 (kΩ)	R2 (kΩ)
1.0	120	180
1.2	120	120
1.35	100	80.6
1.5	80.6	53.6
1.8	80.6	40.2
2.5	80.6	25.5
3.3	40.2	8.87
5	40.2	5.49

9) The recommended parameters are based on 500kHz switching frequency, different output inductors and capacitors affect the recommended values of R1 and R2. For the other components' parameters, please refer to TYPICAL APPLICATION CIRCUITS on 17-19.

Selecting the Inductor

Use a 1μH-to-10μH inductor with a DC current rating at least 25% percent higher than the maximum load current for most applications.

For highest efficiency, use an inductor with a DC resistance less than 15mΩ. For most designs, the inductance value can be derived from the following equation.

$$L_1 = \frac{V_{OUT} \times (V_{IN} - V_{OUT})}{V_{IN} \times \Delta I_L \times f_{OSC}} \quad (2)$$

Where ΔI_L is the inductor ripple current.

Choose the inductor ripple current to be approximately 30% of the maximum load current. The maximum inductor peak current is:

$$I_{L(MAX)} = I_{LOAD} + \frac{\Delta I_L}{2} \quad (3)$$

Use a larger inductor for improved efficiency under light-load conditions—below 100mA.

Selecting the Input Capacitor

The input current to the step-down converter is discontinuous, therefore requires a capacitor to supply the AC current to the step-down converter while maintaining the DC input voltage. Use low ESR capacitors for the best performance. Use ceramic capacitors with X5R or X7R dielectrics for best results because of their low ESR and small temperature coefficients. For most applications, use a 22μF capacitor.

Since C1 absorbs the input switching current, it requires an adequate ripple current rating. The RMS current in the input capacitor can be estimated by:

$$I_{C1} = I_{LOAD} \times \sqrt{\frac{V_{OUT}}{V_{IN}} \times \left(1 - \frac{V_{OUT}}{V_{IN}}\right)} \quad (4)$$

The worse case condition occurs at V_{IN} = 2V_{OUT}, where:

$$I_{C1} = \frac{I_{LOAD}}{2} \quad (5)$$

For simplification, choose an input capacitor with an RMS current rating greater than half of the maximum load current.

The input capacitor can be electrolytic, tantalum or ceramic. When using electrolytic or tantalum capacitors, add a small, high quality ceramic capacitor (e.g. 0.1μF) placed as close to the IC

as possible. When using ceramic capacitors, make sure that they have enough capacitance to provide sufficient charge to prevent excessive voltage ripple at input. The input voltage ripple caused by capacitance can be estimated by:

$$\Delta V_{IN} = \frac{I_{LOAD}}{f_s \times C1} \times \frac{V_{OUT}}{V_{IN}} \times \left(1 - \frac{V_{OUT}}{V_{IN}}\right) \quad (6)$$

Selecting the Output Capacitor

The output capacitor (C2) maintains the DC output voltage. Use ceramic, tantalum, or low-ESR electrolytic capacitors. For best results, use low ESR capacitors to keep the output voltage ripple low. The output voltage ripple can be estimated by:

$$\Delta V_{OUT} = \frac{V_{OUT}}{f_s \times L_1} \times \left(1 - \frac{V_{OUT}}{V_{IN}}\right) \times \left(R_{ESR} + \frac{1}{8 \times f_s \times C2}\right) \quad (7)$$

Where L₁ is the inductor value and R_{ESR} is the equivalent series resistance (ESR) value of the output capacitor.

For ceramic capacitors, the capacitance dominates the impedance at the switching frequency, and the capacitance causes the majority of the output voltage ripple. For simplification, the output voltage ripple can be estimated by:

$$\Delta V_{OUT} = \frac{V_{OUT}}{8 \times f_s^2 \times L_1 \times C2} \times \left(1 - \frac{V_{OUT}}{V_{IN}}\right) \quad (8)$$

For tantalum or electrolytic capacitors, the ESR dominates the impedance at the switching frequency. For simplification, the output ripple can be approximated to:

$$\Delta V_{OUT} = \frac{V_{OUT}}{f_s \times L_1} \times \left(1 - \frac{V_{OUT}}{V_{IN}}\right) \times R_{ESR} \quad (9)$$

The characteristics of the output capacitor also affect the stability of the regulation system. The MP2225 can be optimized for a wide range of capacitance and ESR values.

External Bootstrap Diode

BST voltage may become insufficient at some particular conditions. In these cases an external bootstrap diode can enhance the efficiency of the regulator and help to avoid output ripple caused by BST voltage insufficiency during PFM operation at light load.

For better efficiency, the diode is needed if below two conditions happen at the same time:

- V_{IN} < 5V
- Duty cycle is large: Duty = $\frac{V_{OUT}}{V_{IN}} > 65\%$

To avoid the ripple caused by BST refresh, the diode is needed if below condition happens:

- V_{IN} - V_{OUT} < 2.6V

In these cases, it's recommended to add an external BST diode from the VCC pin to BST pin, as shown in Figure 6.

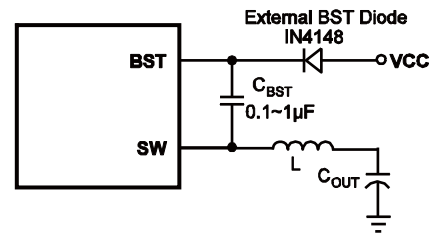

Figure 6: Optional External Bootstrap Diode

The recommended external BST diode is IN4148, and the BST capacitor value is 0.1µF to 1µF.

PC Board Layout⁽⁹⁾

PCB layout is very important for stable operation. Follow these guidelines for best results.

- 1) Connect the input ground to the GND pin using the possible shortest and widest trace.
- 2) Connect the input capacitor to the IN pin using the possible shortest and widest trace.
- 3) Ensure all feedback connections are short and direct. Place the feedback resistors and compensation components as close to the chip as possible.
- 4) Route SW away from sensitive analog areas such as FB.
- 5) Connect AGND to GND plane with single trace.

Notes:

- 10) The recommended layout is based on the Figure 8-15 Typical Application circuit on the next page.

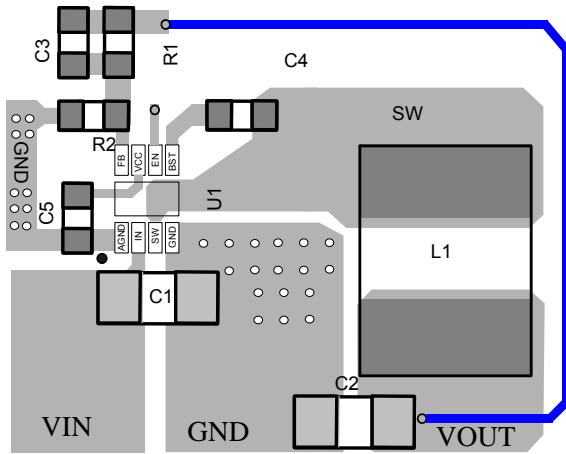
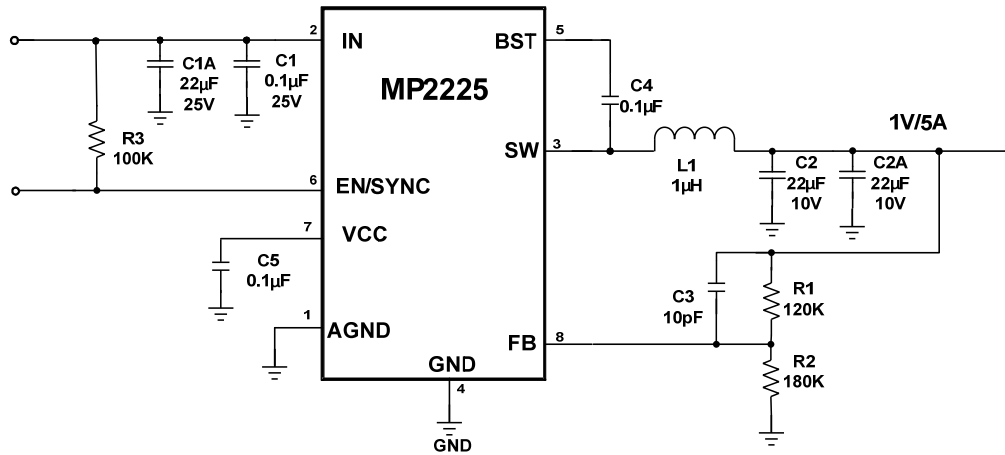
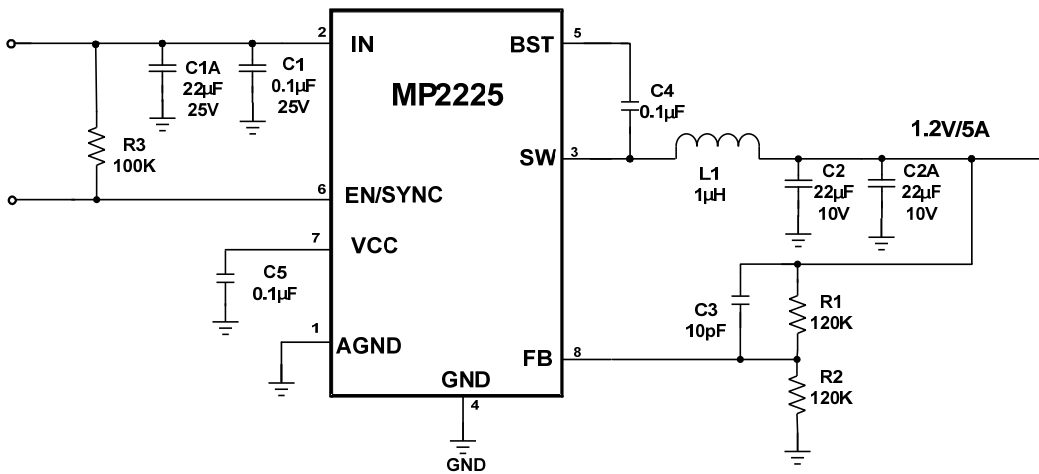
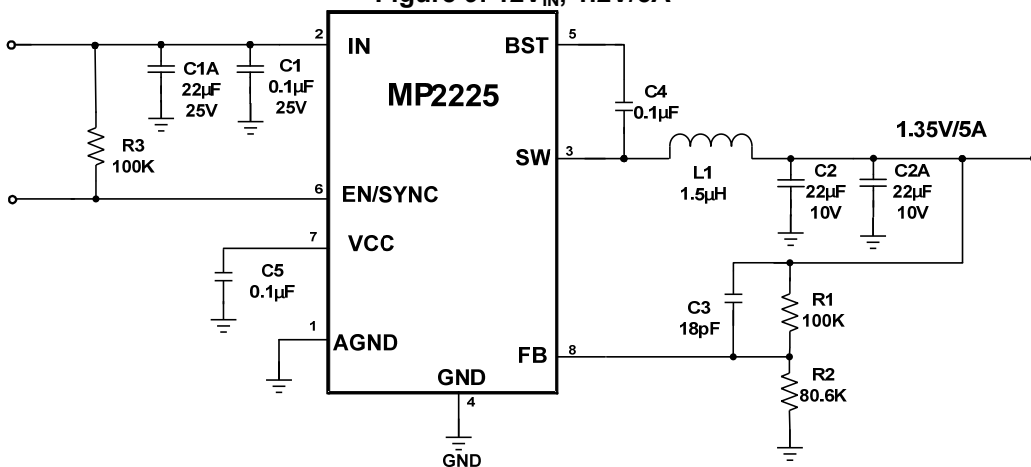

Figure 7: Recommend Layout
Design Example

Below is a design example following the application guidelines for the specifications:

Table 2: Design Example

V_{IN}	12V
V_{OUT}	3.3V
I_{OUT}	5A

The detailed application schematic is shown in Figure 14. The typical performance and circuit waveforms have been shown in the Typical Performance Characteristics section. For more device applications, please refer to the related Evaluation Board Datasheets.

TYPICAL APPLICATION CIRCUITS

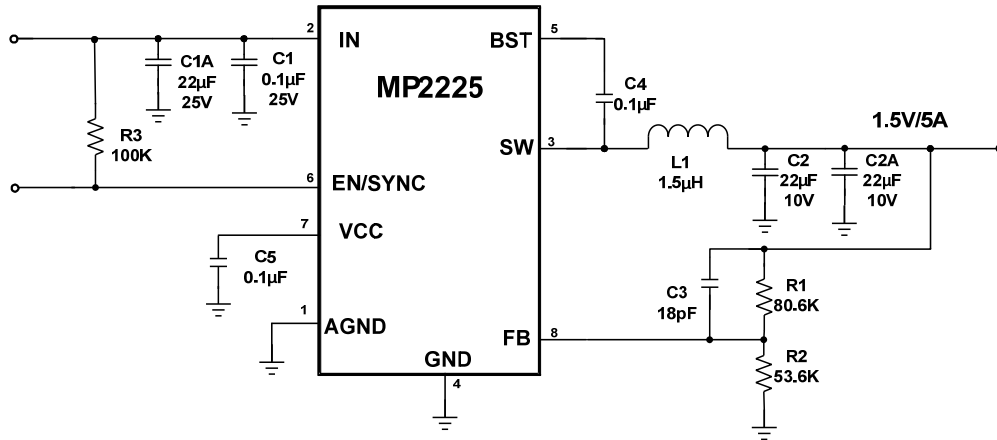
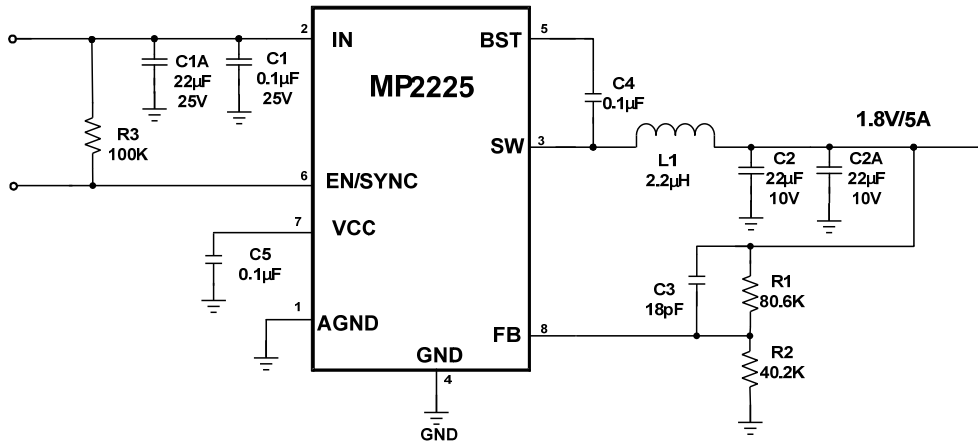
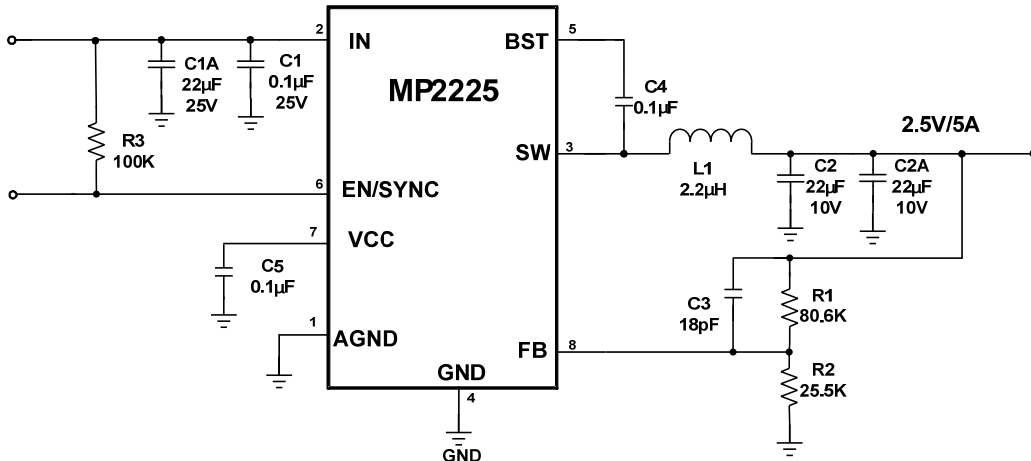
Figure 8: 12V_{IN}, 1V/5A

Figure 9: 12V_{IN}, 1.2V/5A

Figure 10: 12V_{IN}, 1.35V/5A

Figure 11: 12V_{IN}, 1.5V/5A

Figure 12: 12V_{IN}, 1.8V/5A

Figure 13: 12V_{IN}, 2.5V/5A

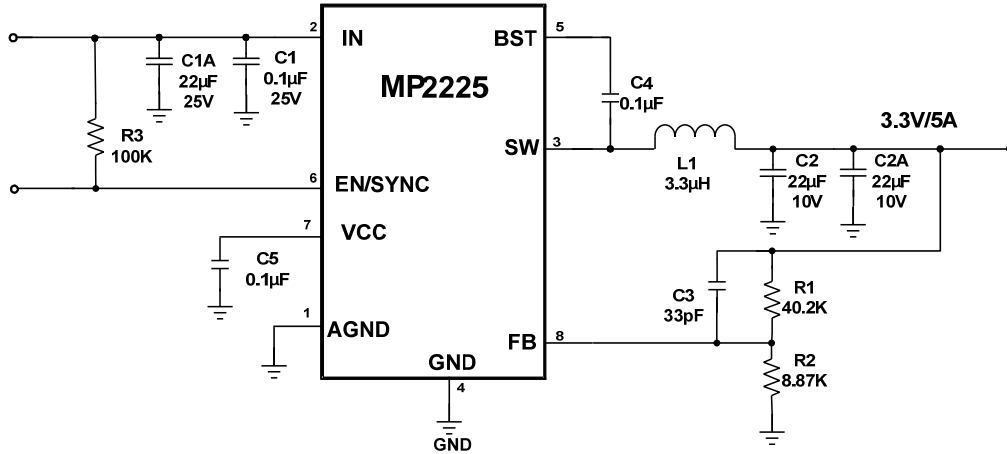

Figure 14: 12V_{IN}, 3.3V/5A

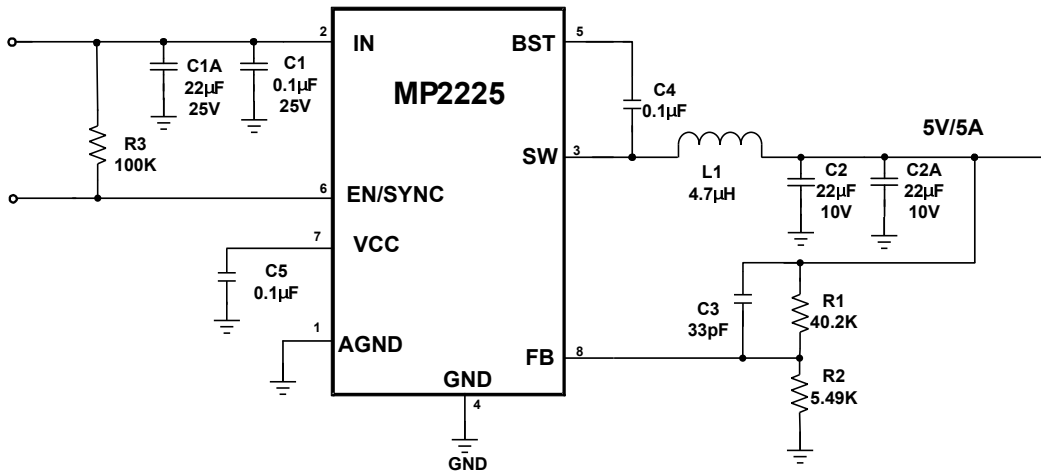
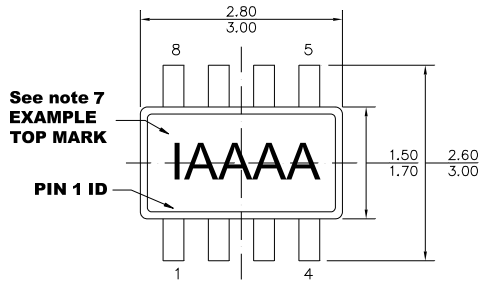
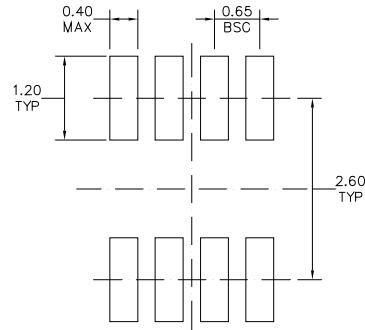
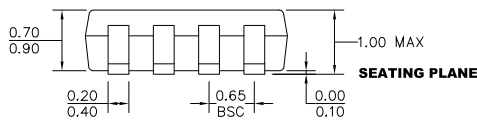
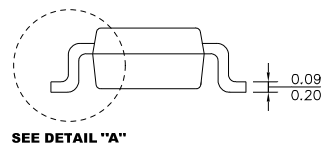
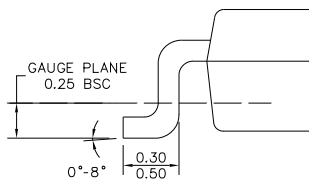

Figure 15: 12V_{IN}, 5V/5A

PACKAGE INFORMATION
TSOT23-8

TOP VIEW

RECOMMENDED LAND PATTERN

FRONT VIEW

SIDE VIEW

DETAIL "A"
NOTE:

- 1) ALL DIMENSIONS ARE IN MILLIMETERS.
- 2) PACKAGE LENGTH DOES NOT INCLUDE MOLD FLASH, PROTRUSION OR GATE BURR.
- 3) PACKAGE WIDTH DOES NOT INCLUDE INTERLEAD FLASH OR PROTRUSION.
- 4) LEAD COPLANARITY (BOTTOM OF LEADS AFTER FORMING) SHALL BE 0.10 MILLIMETERS MAX.
- 5) JEDEC REFERENCE IS MO-193, VARIATION BA.
- 6) DRAWING IS NOT TO SCALE.
- 7) PIN 1 IS LOWER LEFT PIN WHEN READING TOP MARK FROM LEFT TO RIGHT, (SEE EXAMPLE TOP MARK)

NOTICE: The information in this document is subject to change without notice. Please contact MPS for current specifications. Users should warrant and guarantee that third party Intellectual Property rights are not infringed upon when integrating MPS products into any application. MPS will not assume any legal responsibility for any said applications.

Компания «Океан Электроники» предлагает заключение долгосрочных отношений при поставках импортных электронных компонентов на взаимовыгодных условиях!

Наши преимущества:

- Поставка оригинальных импортных электронных компонентов напрямую с производств Америки, Европы и Азии, а так же с крупнейших складов мира;
- Широкая линейка поставок активных и пассивных импортных электронных компонентов (более 30 млн. наименований);
- Поставка сложных, дефицитных, либо снятых с производства позиций;
- Оперативные сроки поставки под заказ (от 5 рабочих дней);
- Экспресс доставка в любую точку России;
- Помощь Конструкторского Отдела и консультации квалифицированных инженеров;
- Техническая поддержка проекта, помощь в подборе аналогов, поставка прототипов;
- Поставка электронных компонентов под контролем ВП;
- Система менеджмента качества сертифицирована по Международному стандарту ISO 9001;
- При необходимости вся продукция военного и аэрокосмического назначения проходит испытания и сертификацию в лаборатории (по согласованию с заказчиком);
- Поставка специализированных компонентов военного и аэрокосмического уровня качества (Xilinx, Altera, Analog Devices, Intersil, Interpoint, Microsemi, Actel, Aeroflex, Peregrine, VPT, Syfer, Eurofarad, Texas Instruments, MS Kennedy, Miteq, Cobham, E2V, MA-COM, Hittite, Mini-Circuits, General Dynamics и др.);

Компания «Океан Электроники» является официальным дистрибьютором и эксклюзивным представителем в России одного из крупнейших производителей разъемов военного и аэрокосмического назначения «JONHON», а так же официальным дистрибьютором и эксклюзивным представителем в России производителя высокотехнологичных и надежных решений для передачи СВЧ сигналов «FORSTAR».



JONHON

«JONHON» (основан в 1970 г.)

Разъемы специального, военного и аэрокосмического назначения:

(Применяются в военной, авиационной, аэрокосмической, морской, железнодорожной, горно- и нефтедобывающей отраслях промышленности)

«FORSTAR» (основан в 1998 г.)

ВЧ соединители, коаксиальные кабели, кабельные сборки и микроволновые компоненты:

(Применяются в телекоммуникациях гражданского и специального назначения, в средствах связи, РЛС, а так же военной, авиационной и аэрокосмической отраслях промышленности).



Телефон: 8 (812) 309-75-97 (многоканальный)

Факс: 8 (812) 320-03-32

Электронная почта: ocean@oceanchips.ru

Web: <http://oceanchips.ru/>

Адрес: 198099, г. Санкт-Петербург, ул. Калинина, д. 2, корп. 4, лит. А