



Micro Commercial Components



Micro Commercial Components  
 20736 Marilla Street Chatsworth  
 CA 91311  
 Phone: (818) 701-4933  
 Fax: (818) 701-4939

# MCAC80N06Y

## N-Channel Power MOSFET

### Features

- Trench Power MV MOSFET technology
- Very low on-resistance  $R_{DS(ON)}$
- Halogen free available upon request by adding suffix "-HF"
- Epoxy meets UL 94 V-0 flammability rating
- Moisture Sensitivity Level 1

### Maximum Ratings @ 25°C Unless Otherwise Specified

Symbol	Parameter	Rating	Unit	
$V_{DS}$	Drain-source Voltage	60	V	
$I_D$	Drain Current-Continuous (Note 7)	$T_C = 25^\circ\text{C}$	80	A
		$T_C = 100^\circ\text{C}$	58	A
$I_{DM}$	Pulsed Drain Current (Note 3)	320	A	
$R_{thJA}$	Maximum Junction to Ambient $t \leq 10\text{s}$ (Note1) Steady-State(Note1,4)		15	$^\circ\text{C/W}$
			43	$^\circ\text{C/W}$
$R_{thJC}$	Maximum Junction to Case Steady-State	1.47	$^\circ\text{C/W}$	
$V_{GS}$	Gate-source Voltage	$\pm 20$	V	
$P_{DSM}$	Maximum Power Dissipation (Note 1)	$T_C = 25^\circ\text{C}$	85	W
		$T_C = 100^\circ\text{C}$	34	W
$E_{AS}$	Single pulse avalanche energy (Note 3)	450	mj	
$T_J$	Operating Junction Temperature	-55 to +150	$^\circ\text{C}$	
$T_{STG}$	Storage Temperature	-55 to +150	$^\circ\text{C}$	

### DFN5060

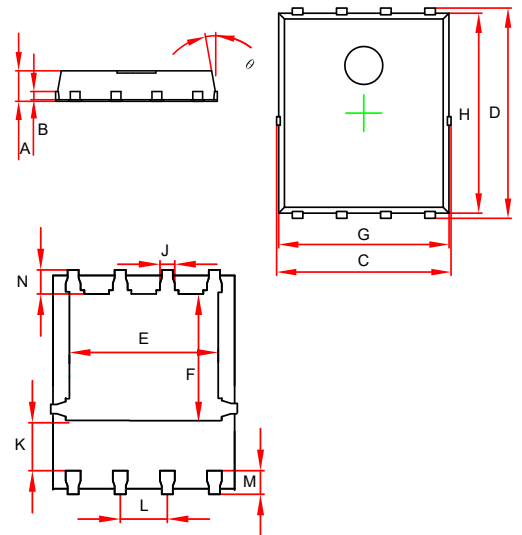

DIM	Dimensions				NOTE
	INCHES		MM		
	MIN	MAX	MIN	MAX	
A	0.035	.039	0.900	1.000	
B	0.010REF.		0.254REF.		
C	0.193	0.200	4.900	5.100	
D	0.232	0.240	5.900	6.100	
E	0.148	0.163	3.750	4.150	
F	0.130	0.142	3.300	3.600	
G	0.189	0.197	4.800	5.000	
H	0.222	0.230	5.650	5.850	
K	0.047	0.059	1.200	1.500	
J	0.014	0.018	0.350	0.450	
L	0.048	0.052	1.220	1.320	
M	0.020	0.028	0.510	0.710	
N	0.020	0.028	0.510	0.710	

### EQUIVALENT CIRCUIT

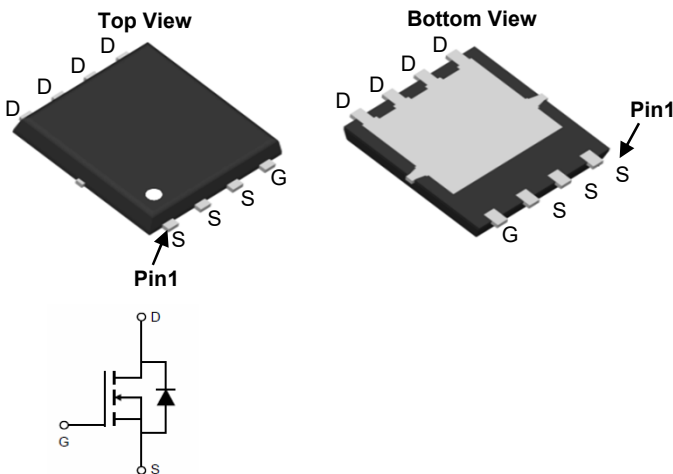

**ELECTRICAL CHARACTERISTICS**( $T_a=25^\circ\text{C}$  unless otherwise specified)

Symbol	Parameter	Conditions	Min	Typ	Max	Units
<b>STATIC PARAMETERS</b>						
$BV_{DSS}$	Drain-Source Breakdown Voltage	$I_D=250\mu\text{A}$ , $V_{GS}=0\text{V}$	60	65		V
$I_{DSS}$	Zero Gate Voltage Drain Current	$V_{DS}=60\text{V}$ , $V_{GS}=0\text{V}$ $T_J=55^\circ\text{C}$			1	$\mu\text{A}$
					5	
$I_{GSS}$	Gate-Body leakage current	$V_{DS}=0\text{V}$ , $V_{GS}=\pm 20\text{V}$			$\pm 100$	nA
$V_{GS(th)}$	Gate Threshold Voltage	$V_{DS}=V_{GS}$ , $I_D=250\mu\text{A}$	1.1	1.7	2.5	V
$R_{DS(ON)}$	Static Drain-Source On-Resistance	$V_{GS}=10\text{V}$ , $I_D=40\text{A}$		3.5	4.2	$\text{m}\Omega$
		$V_{GS}=4.5\text{V}$ , $I_D=40\text{A}$		4.0	5.2	$\text{m}\Omega$
$g_{FS}$	Diode Forward Voltage	$V_{DS}=5\text{V}$ , $I_D=40\text{A}$	30			S
$V_{SD}$	Diode Forward Voltage	$I_S=40\text{A}$ , $V_{GS}=0\text{V}$		0.85	0.99	V
$I_S$	Maximum Body-Diode Continuous Current (Note 7)				80	A
<b>DYNAMIC PARAMETERS</b>						
$C_{iss}$	Input Capacitance	$V_{GS}=0\text{V}$ , $V_{DS}=30\text{V}$ , $f=1\text{MHz}$		3980		pF
$C_{oss}$	Output Capacitance			690		pF
$C_{rss}$	Reverse Transfer Capacitance			24		pF
$R_g$	Gate resistance	$V_{GS}=0\text{V}$ , $V_{DS}=0\text{V}$ , $f=1\text{MHz}$		2.5		$\Omega$
<b>SWITCHING PARAMETERS</b>						
$Q_g(10\text{V})$	Total Gate Charge	$V_{GS}=10\text{V}$ , $V_{DS}=30\text{V}$ , $I_D=40\text{A}$		67		nC
$Q_g(4.5\text{V})$	Total Gate Charge			32		nC
$Q_{gs}$	Gate Source Charge			12		nC
$Q_{gd}$	Gate Drain Charge			8.5		nC
$t_{D(on)}$	Turn-on Delay Time	$V_{GS}=10\text{V}$ , $V_{DS}=15\text{V}$ , $R_L=2.5\Omega$ , $R_{GEN}=3\Omega$		15		ns
$t_r$	Turn-on Rise Time			8		ns
$t_{D(off)}$	Turn-off Delay Time			48		ns
$t_f$	Turn-off Fall Time			12		ns
$t_{rr}$	Body Diode Reverse Recovery Time	$I_F=I_S$ , $di/dt=500\text{A/us}$		48		ns
$Q_{rr}$	Body Diode Reverse Recovery charge	$I_F=I_S$ , $di/dt=500\text{A/us}$		60		nC

Note:

- The value of  $R_{\theta JA}$  is measured with the device mounted on 1in2 FR - 4 board with 2oz. Copper, in a still air environment with  $T_A=25^\circ\text{C}$ . The Power dissipation PDSM is based on  $R_{\theta JA} t \leq 10\text{s}$  and the maximum allowed junction temperature of  $150^\circ\text{C}$ . The value in any given application depends on the user's specific board design.
- The power dissipation PD is based on  $T_J(\text{MAX})=175^\circ\text{C}$ , using junction - to - case thermal resistance, and is more useful in setting the upper dissipation limit for cases where additional heatsinking is used.
- Single pulse width limited by junction temperature  $T_J(\text{MAX})=175^\circ\text{C}$ .
- The  $R_{\theta JA}$  is the sum of the thermal impedance from junction to case  $R_{\theta JC}$  and case to ambient.
- The static characteristics in Figures 1 to 6 are obtained using  $<300\text{ns}$  pulses, duty cycle 0.5% max.
- These curves are based on the junction - to - case thermal impedance which is measured with the device mounted to a large heatsink, assuming a maximum junction temperature of  $T_J(\text{MAX})=175^\circ\text{C}$ . The SOA curve provides a single pulse rating.
- The maximum current rating is package limited.

## Typical Electrical and Thermal Characteristics

Fig 1: Output Characteristics

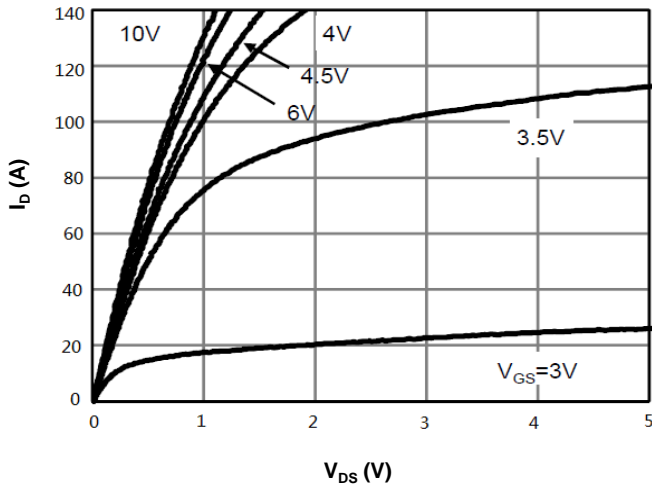

Fig 2: Transfer Characteristics

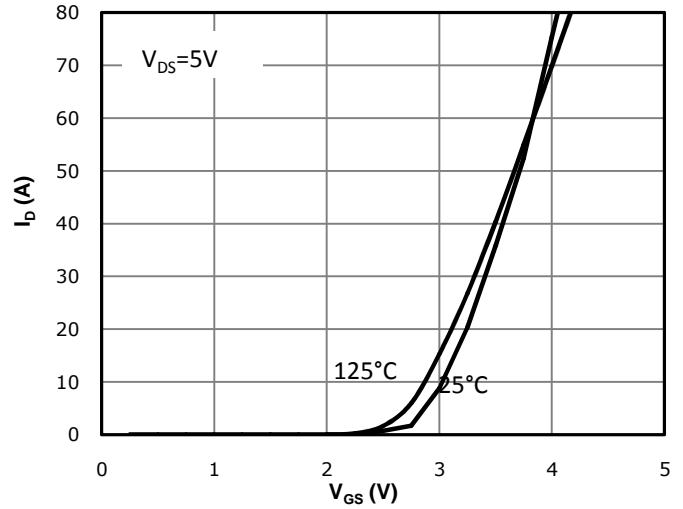

Fig 3:  $R_{DS(on)}$  vs Drain Current and Gate Voltage

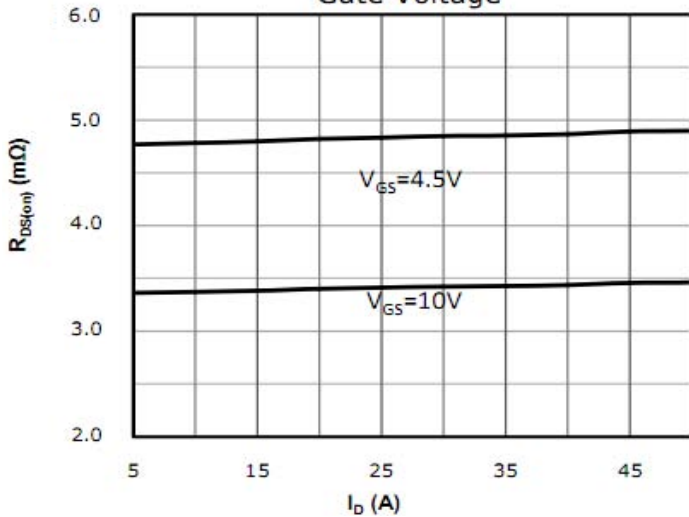

Fig 4: Capacitance Characteristics

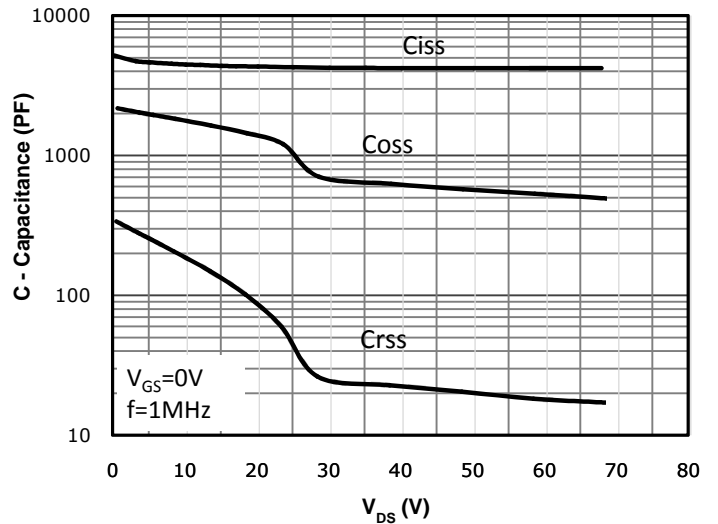

Fig 5:  $R_{DS(on)}$  vs. Temperature

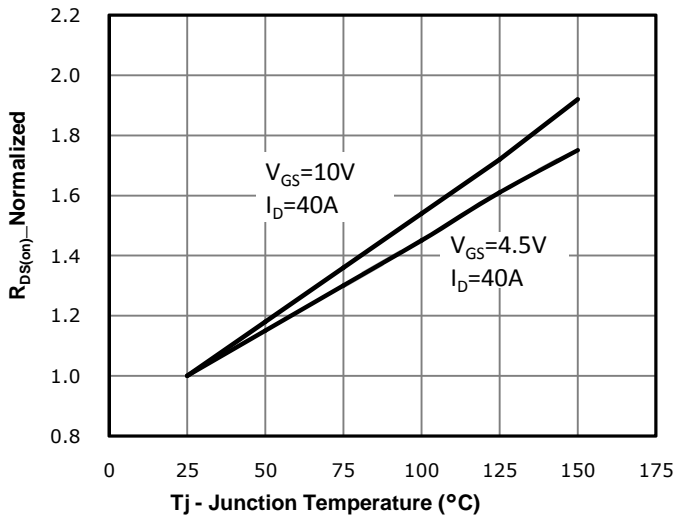
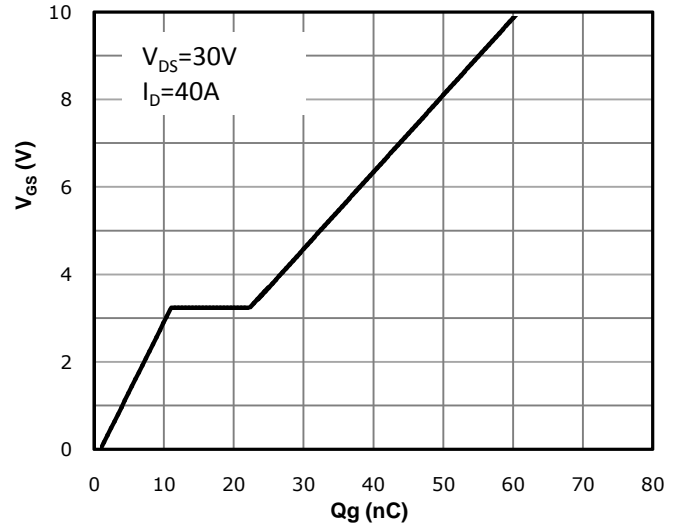

Fig 6: Gate Charge Characteristics



**Typical Electrical and Thermal Characteristics**

Fig 7: Body-diode Forward Characteristics

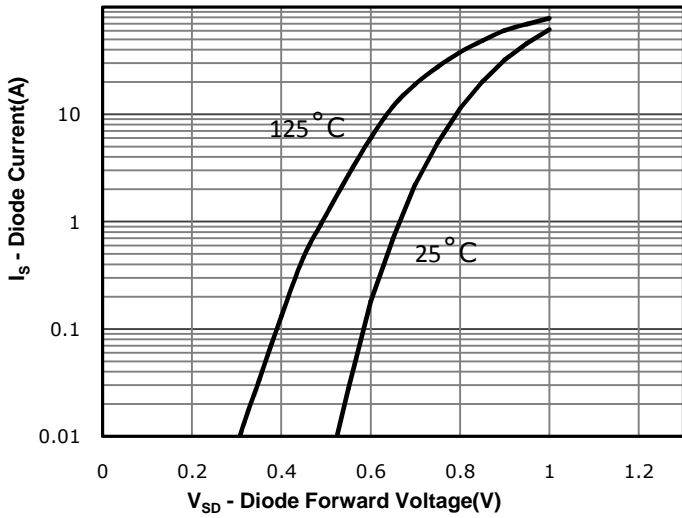

Fig 8: Drain Current Derating

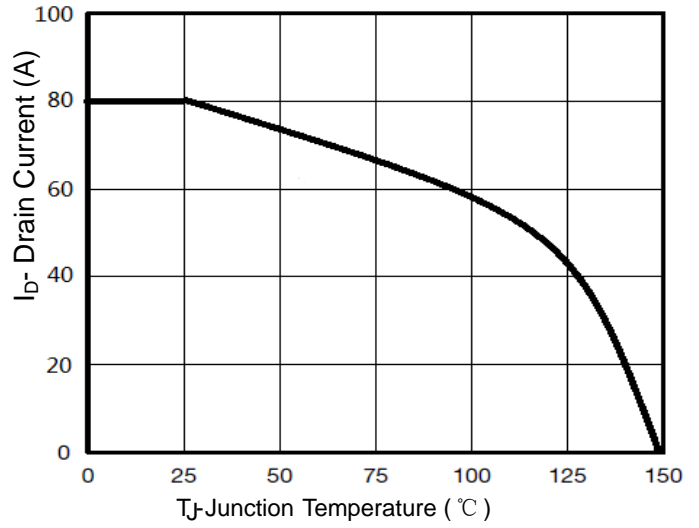

Fig 9: Power Dissipation

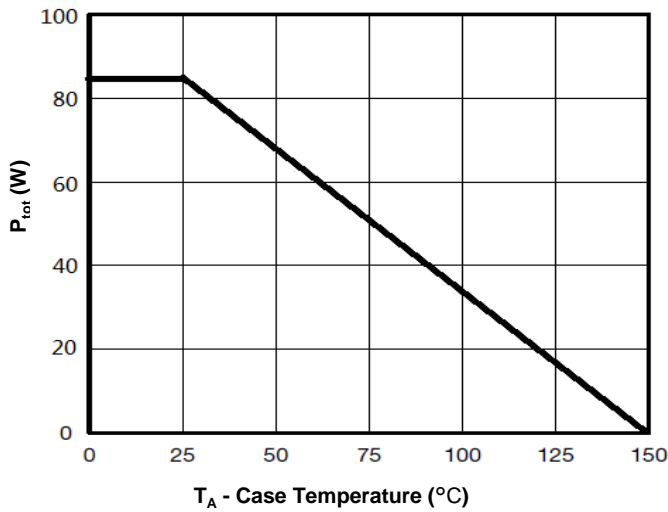

Fig 10: Safe Operation Area

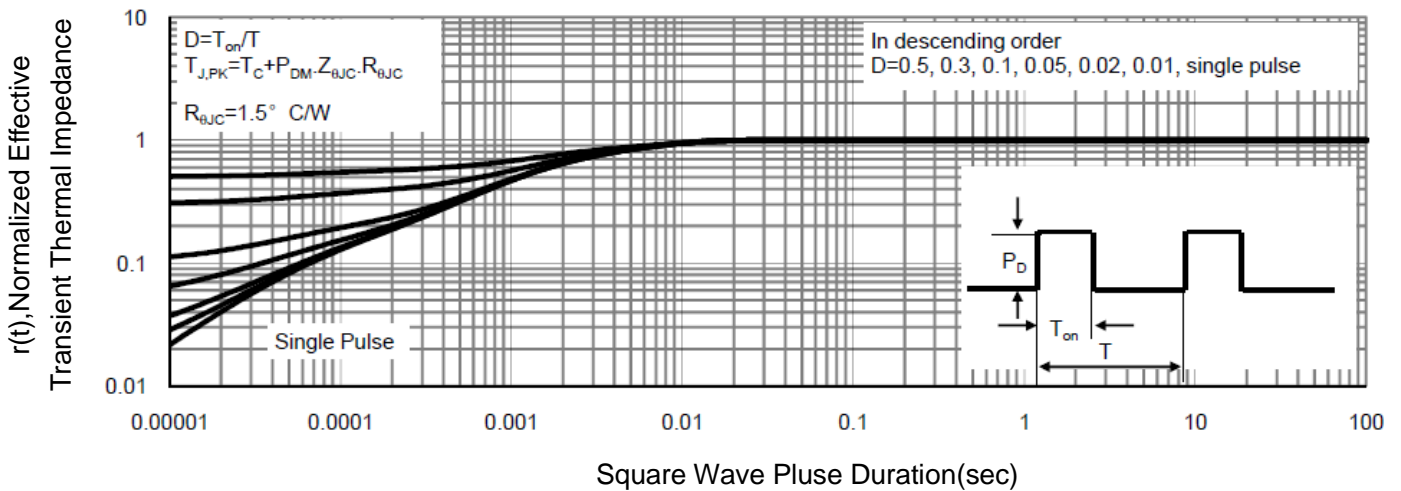
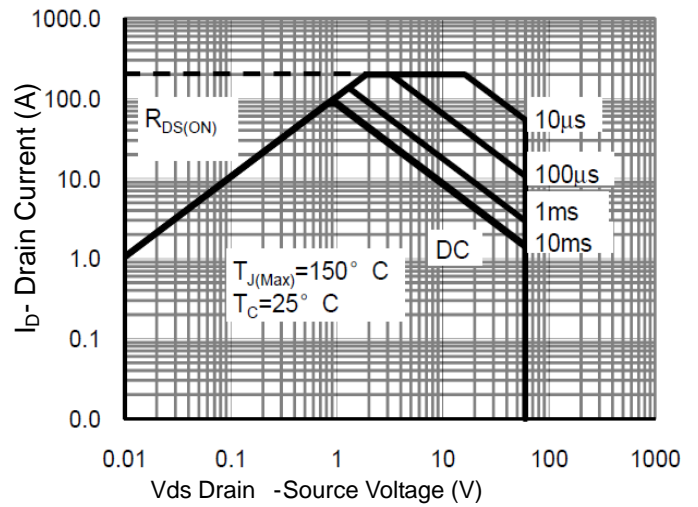

Fig 11: Normalized Maximum Transient Thermal Impedance



Micro Commercial Components

## Ordering Information :

Device	Packing
Part Number-TP	Tape&Reel:5Kpcs/Reel

Note : Adding "-HF" suffix for halogen free, eg. Part Number-TP-HF

### \*\*\*IMPORTANT NOTICE\*\*\*

**Micro Commercial Components Corp.** reserves the right to make changes without further notice to any product herein to make corrections, modifications , enhancements , improvements , or other changes . **Micro Commercial Components Corp .** does not assume any liability arising out of the application or use of any product described herein; neither does it convey any license under its patent rights ,nor the rights of others . The user of products in such applications shall assume all risks of such use and will agree to hold **Micro Commercial Components Corp .** and all the companies whose products are represented on our website, harmless against all damages.

### \*\*\*LIFE SUPPORT\*\*\*

MCC's products are not authorized for use as critical components in life support devices or systems without the express written approval of Micro Commercial Components Corporation.

### \*\*\*CUSTOMER AWARENESS\*\*\*

Counterfeiting of semiconductor parts is a growing problem in the industry. Micro Commercial Components (MCC) is taking strong measures to protect ourselves and our customers from the proliferation of counterfeit parts. MCC strongly encourages customers to purchase MCC parts either directly from MCC or from Authorized MCC Distributors who are listed by country on our web page cited below. Products customers buy either from MCC directly or from Authorized MCC Distributors are genuine parts, have full traceability, meet MCC's quality standards for handling and storage. **MCC will not provide any warranty coverage or other assistance for parts bought from Unauthorized Sources.** MCC is committed to combat this global problem and encourage our customers to do their part in stopping this practice by buying direct or from authorized distributors.

Компания «Океан Электроники» предлагает заключение долгосрочных отношений при поставках импортных электронных компонентов на взаимовыгодных условиях!

Наши преимущества:

- Поставка оригинальных импортных электронных компонентов напрямую с производств Америки, Европы и Азии, а так же с крупнейших складов мира;
- Широкая линейка поставок активных и пассивных импортных электронных компонентов (более 30 млн. наименований);
- Поставка сложных, дефицитных, либо снятых с производства позиций;
- Оперативные сроки поставки под заказ (от 5 рабочих дней);
- Экспресс доставка в любую точку России;
- Помощь Конструкторского Отдела и консультации квалифицированных инженеров;
- Техническая поддержка проекта, помощь в подборе аналогов, поставка прототипов;
- Поставка электронных компонентов под контролем ВП;
- Система менеджмента качества сертифицирована по Международному стандарту ISO 9001;
- При необходимости вся продукция военного и аэрокосмического назначения проходит испытания и сертификацию в лаборатории (по согласованию с заказчиком);
- Поставка специализированных компонентов военного и аэрокосмического уровня качества (Xilinx, Altera, Analog Devices, Intersil, Interpoint, Microsemi, Actel, Aeroflex, Peregrine, VPT, Syfer, Eurofarad, Texas Instruments, MS Kennedy, Miteq, Cobham, E2V, MA-COM, Hittite, Mini-Circuits, General Dynamics и др.);

Компания «Океан Электроники» является официальным дистрибьютором и эксклюзивным представителем в России одного из крупнейших производителей разъемов военного и аэрокосмического назначения «JONHON», а так же официальным дистрибьютором и эксклюзивным представителем в России производителя высокотехнологичных и надежных решений для передачи СВЧ сигналов «FORSTAR».



## JONHON

«JONHON» (основан в 1970 г.)

Разъемы специального, военного и аэрокосмического назначения:

(Применяются в военной, авиационной, аэрокосмической, морской, железнодорожной, горно- и нефтедобывающей отраслях промышленности)

«FORSTAR» (основан в 1998 г.)

ВЧ соединители, коаксиальные кабели, кабельные сборки и микроволновые компоненты:

(Применяются в телекоммуникациях гражданского и специального назначения, в средствах связи, РЛС, а так же военной, авиационной и аэрокосмической отраслях промышленности).



Телефон: 8 (812) 309-75-97 (многоканальный)

Факс: 8 (812) 320-03-32

Электронная почта: [ocean@oceanchips.ru](mailto:ocean@oceanchips.ru)

Web: <http://oceanchips.ru/>

Адрес: 198099, г. Санкт-Петербург, ул. Калинина, д. 2, корп. 4, лит. А