

General Description

The HXC42200 is a bi-directional Dual Channel CDR / Retimer for retiming data rates from 25Gbps to 28.05Gbps. It is optimized for 25.78125Gbps Ethernet, OIF CEI-28G-VSR and OTU-4 Optical Transport applications. The HXC42200 can be used in either direction of a transceiver module can be adopted into SFP28+ modules because of its low 100mW per channel power dissipation. In Bypass operation, the HXC42200 supports legacy data rates up to 16Gbps.

The HXC42200 provides programmable and adaptive equalization in the receiver and programmable de-emphasis in the transmitter to compensate for channel Insertion Loss and ISI. In the receive direction, the programmable / adaptive CTLE provides up to 16dB of equalization and a 1-tap DFE provides additional compensation. In the transmit direction, the programmable, 4-bit, de-emphasis with 3-tap FIR filter provides a 12dB control range.

Auto DC-offset calibration is complemented with auto phase calibration and the unique CDR / Retimer architecture enables independent receive and transmit CDR loop bandwidth optimization for increased Jitter Tolerance and reduced Jitter Transfer performance.

The HXC42200 is able to be used with or without a reference clock with a built-in, single 14GHz master VCO providing the oscillator output for each channel.

Multiple Built-in Self-Test (BIST) functions such as a PRBS generator / checker, Jitter Tolerance, Eye Open Monitor, and single lane loopback are supported for module level testing.

The HXC42200 has an I²C interface that is used to set the start-up operating mode for the internal state machine which performs all required calibrations and settings.

The HXC42200 is packaged in a 4x4mm BGA of 0.5mm ball pitch.

Applications

- 25GBASE Ethernet SFP28 SR/MR/LR optical modules
- Supports OTU4 28Gbps operation for OTL4.4 as defined in ITU Rec G.709
- 32G Fibre Channel modules
- OIF CEI-28G-VSR/MR retimed interface
- 25G InfiniBand EDR active optical cables

Features

- Dual 25 - 28Gbps CDR / Retimer
 - Also provides a half-rate mode for 12.5 – 14Gbps operation
- Bypass-mode to support legacy data rate up to 16Gbps
- Programmable 3-tap output de-emphasis for transmitter side
- Adaptive linear equalizer and adaptive decision-feedback equalizer (DFE) to cover up to 16dB lossy channel in receiver side
- Low sensitivity of 25mV_{PPD} and adjustable threshold level of data sampler
- Reference-less and Master channel-less operation
- Independent, adaptive bandwidth control in RX CDR for optimum jitter tolerance
- Internal and automatic DC and phase offset calibrations
- On-chip testability; EOM, JTOL, PRBS generator/checker, local/remote loopback,
- Polarity (P/N) inversion
- I²C control interface
- 4x4mm, 1mm - 0.5m pitch, 49 ball FCBGA

Ordering Information

Part Number ¹	Temp Range	Package - # Balls
HXC42200-xFI	-40°C to +85°	4x4mm FCBGA - xx
HXC42200EVB		

Note¹ – Where ‘x’ denotes Product Carrier type for shipping:

- R = Tape and Reel
- C = Bulk – Carrier Tray
- B = Bulk - Tubes

For price, delivery schedules, and to place orders, please contact IDT: www.IDT.com/go/sales

Device Diagram

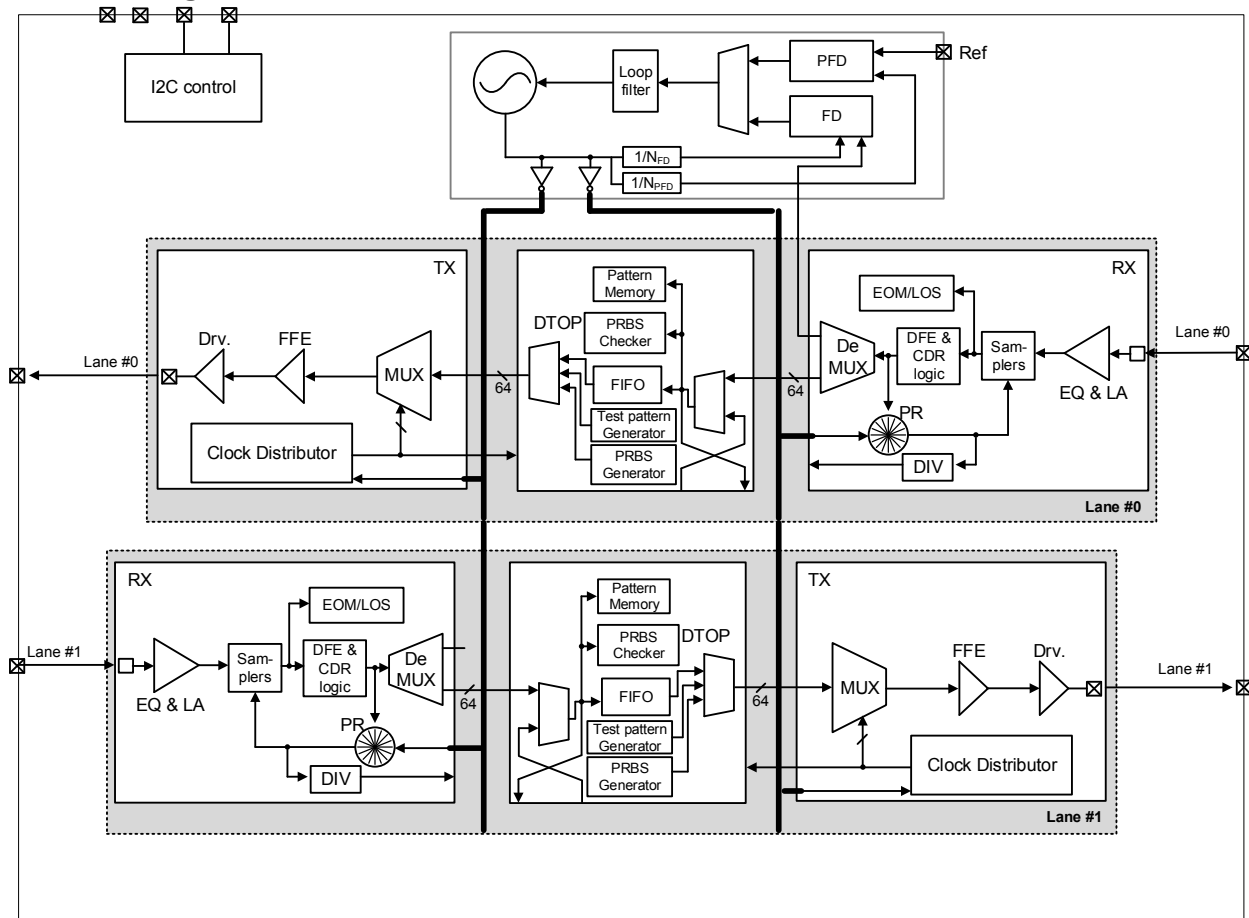

Figure 1: Device Block Diagram

**Corporate Headquarters**

6024 Silver Creek Valley Road
San Jose, CA 95138

www.IDT.com

Sales

1-800-345-7015 or 408-284-8200
Fax: 408-284-2775

www.IDT.com/go/sales

Tech Support

www.IDT.com/go/support

DISCLAIMER Integrated Device Technology, Inc. (IDT) and its affiliated companies (herein referred to as "IDT") reserve the right to modify the products and/or specifications described herein at any time, without notice, at IDT's sole discretion. Performance specifications and operating parameters of the described products are determined in an independent state and are not guaranteed to perform the same way when installed in customer products. The information contained herein is provided without representation or warranty of any kind, whether express or implied, including, but not limited to, the suitability of IDT's products for any particular purpose, an implied warranty of merchantability, or non-infringement of the intellectual property rights of others. This document is presented only as a guide and does not convey any license under intellectual property rights of IDT or any third parties.

IDT's products are not intended for use in applications involving extreme environmental conditions or in life support systems or similar devices where the failure or malfunction of an IDT product can be reasonably expected to significantly affect the health or safety of users. Anyone using an IDT product in such a manner does so at their own risk, absent an express, written agreement by IDT.

Integrated Device Technology, IDT and the IDT logo are trademarks or registered trademarks of IDT and its subsidiaries in the United States and other countries. Other trademarks used herein are the property of IDT or their respective third party owners. For datasheet type definitions and a glossary of common terms, visit www.idt.com/go/glossary. All contents of this document are copyright of Integrated Device Technology, Inc. All rights reserved.

Компания «Океан Электроники» предлагает заключение долгосрочных отношений при поставках импортных электронных компонентов на взаимовыгодных условиях!

Наши преимущества:

- Поставка оригинальных импортных электронных компонентов напрямую с производств Америки, Европы и Азии, а так же с крупнейших складов мира;
- Широкая линейка поставок активных и пассивных импортных электронных компонентов (более 30 млн. наименований);
- Поставка сложных, дефицитных, либо снятых с производства позиций;
- Оперативные сроки поставки под заказ (от 5 рабочих дней);
- Экспресс доставка в любую точку России;
- Помощь Конструкторского Отдела и консультации квалифицированных инженеров;
- Техническая поддержка проекта, помощь в подборе аналогов, поставка прототипов;
- Поставка электронных компонентов под контролем ВП;
- Система менеджмента качества сертифицирована по Международному стандарту ISO 9001;
- При необходимости вся продукция военного и аэрокосмического назначения проходит испытания и сертификацию в лаборатории (по согласованию с заказчиком);
- Поставка специализированных компонентов военного и аэрокосмического уровня качества (Xilinx, Altera, Analog Devices, Intersil, Interpoint, Microsemi, Actel, Aeroflex, Peregrine, VPT, Syfer, Eurofarad, Texas Instruments, MS Kennedy, Miteq, Cobham, E2V, MA-COM, Hittite, Mini-Circuits, General Dynamics и др.);

Компания «Океан Электроники» является официальным дистрибьютором и эксклюзивным представителем в России одного из крупнейших производителей разъемов военного и аэрокосмического назначения «JONHON», а так же официальным дистрибьютором и эксклюзивным представителем в России производителя высокотехнологичных и надежных решений для передачи СВЧ сигналов «FORSTAR».



JONHON

«JONHON» (основан в 1970 г.)

Разъемы специального, военного и аэрокосмического назначения:

(Применяются в военной, авиационной, аэрокосмической, морской, железнодорожной, горно- и нефтедобывающей отраслях промышленности)

«FORSTAR» (основан в 1998 г.)

ВЧ соединители, коаксиальные кабели, кабельные сборки и микроволновые компоненты:

(Применяются в телекоммуникациях гражданского и специального назначения, в средствах связи, РЛС, а так же военной, авиационной и аэрокосмической отраслях промышленности).



Телефон: 8 (812) 309-75-97 (многоканальный)

Факс: 8 (812) 320-03-32

Электронная почта: ocean@oceanchips.ru

Web: <http://oceanchips.ru/>

Адрес: 198099, г. Санкт-Петербург, ул. Калинина, д. 2, корп. 4, лит. А