

50mA VOLTAGE REGULATOR (Wide Input Voltage Range)

NO.EA-153-070802

OUTLINE

The R1515x series are CMOS-based positive voltage regulator (VR) ICs featuring 50mA output current. The R1515xxxxB has features of high input voltage and ultra-low supply current. A peak current limit circuit, a short current limit circuit, and a thermal shutdown circuit are built in the R1515x series.

The operating temperature is -40°C to 105°C and the maximum input voltage is 36V, the R1515x series are very suitable for power source of car accessories.

The regulator output voltage is fixed in the R1515xxxxB and can be selected with a step of 0.1V in the range of 2.0V to 12.0V. Output voltage accuracy is $\pm 2\%$.

The packages for these ICs are the SOT-89-5 for space saving and the HSOP-6J for higher power applications.

FEATURES

- Input Voltage Max. 36V
- Supply Current Typ. $9\mu\text{A}$
- Standby Current Typ. $0.1\mu\text{A}$
- Temperature-Drift Coefficient of Output Voltage ... Typ. $\pm 100\text{ppm}/^{\circ}\text{C}$
- Output Current Min. 50mA ($V_{\text{IN}}=V_{\text{OUT}}+3.0\text{V}$; R1515x050B)
- Line Regulation Typ. $0.05\%/V$
- Output Voltage Accuracy..... $\pm 2\%$
- Packages SOT-89-5, HSOP-6J
- Output Voltage Range..... Stepwise setting with a step of 0.1V in the range of 2.0V to 12.0V is possible (refer to Selection Guide).
- Built-in Peak Current Limit Circuit
- Built-in Short Current Limit Circuit
- Built-in Thermal Shutdown Circuit
- Operating Temperature -40°C to 105°C

APPLICATIONS

- Power source for home appliances such as refrigerators, rice cookers, electric water warmers, etc.
- Power source for car audio equipment, car navigation system, ETC system, etc.
- Power source for notebook PCs, digital TVs, cordless phones, and private LAN system, etc.
- Power source for office equipment machines such as copiers, printers, facsimiles, scanners, projectors, etc.
- Power source for the backup circuit for keyless entry system, etc.

BLOCK DIAGRAMS

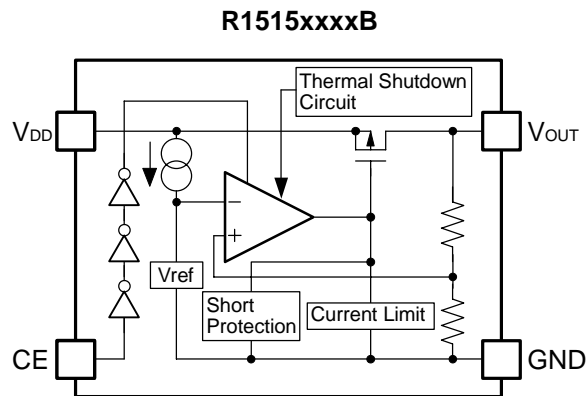

SELECTION GUIDE

The output voltage, the active type, and the taping type for the ICs can be selected at the user's request. The selection can be made with designating the part number as shown below;

R1515xxxx-xx-x ← Part Number
 ↑ ↑ ↑ ↑ ↑
 a b c d e

Code	Contents
a	Designation of Package Type: H: SOT-89-5 S: HSOP-6J
b	Setting Output Voltage (V_{OUT}): Stepwise setting with a step of 0.1V in the range of 2.0V to 12.0V is possible.
c	Designation of Active Type: B: active high
d	Designation of Taping Type: T1 (SOT-89-5), E2 (HSOP-6J) (Refer to Taping Specifications)
e	Designation of composition of pin plating: -F: Lead free plating

PIN CONFIGURATIONS

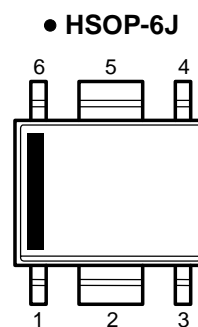
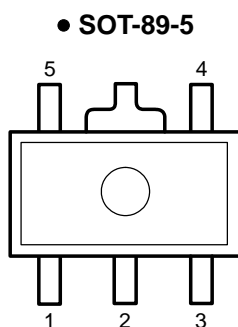

PIN DESCRIPTIONS

• SOT-89-5

Pin No.	Symbol	Description
1	V_{OUT}	Output Pin
2	GND*	Ground Pin
3	CE	Chip Enable Pin ("H" Active)
4	GND*	Ground Pin
5	V_{DD}	Input Pin

• HSOP-6J

Pin No.	Symbol	Description
1	V_{OUT}	Output Pin
2	GND*	Ground Pin
3	CE	Chip Enable Pin ("H" Active)
4	GND*	Ground Pin
5	GND*	Ground Pin
6	V_{DD}	Input Pin

*) No.2 pin and No.4 pin of SOT89-5 package must be wired to the GND plane. No.2 pin, No.4 pin and No.5 pin of HSOP-6J package must be wired to the GND plane when it is mounted on board.

ABSOLUTE MAXIMUM RATINGS

Symbol	Item	Rating	Unit
V_{IN}	Input Voltage	-0.3 to 50	V
V_{IN}	Peak Input Voltage * ¹	60	V
V_{CE}	Input Voltage (CE Pin)	-0.3 to $V_{IN}+0.3 \leq 50$	V
V_{OUT}	Output Voltage	-0.3 to $V_{IN}+0.3 \leq 50$	V
I_{OUT}	Output Current	150	mA
P_D	Power Dissipation (SOT-89-5) * ²	900	mW
	Power Dissipation (HSOP-6J) * ²	1700	
T_{opt}	Operating Temperature Range	-40 to 105	°C
T_{stg}	Storage Temperature Range	-55 to 125	°C

*1) Duration time=200ms

*2) For Power Dissipation, please refer to PACKAGE INFORMATION to be described.

ABSOLUTE MAXIMUM RATINGS

Absolute Maximum ratings are threshold limit values that must not be exceeded ever for an instant under any conditions. Moreover, such values for any two items must not be reached simultaneously. Operation above these absolute maximum ratings may cause degradation or permanent damage to the device. These are stress ratings only and do not necessarily imply functional operation below these limits.

ELECTRICAL CHARACTERISTICS

• R1515xxxxB

T_{opt}=25°C

Symbol	Item	Conditions	Min.	Typ.	Max.	Unit
V _{IN}	Input Voltage		4		36	V
I _{SS}	Supply Current	V _{IN} =V _{OUT} +3.0V, I _{OUT} =0mA		9	20	μA
I _{standby}	Standby Current	V _{IN} =36V, V _{CE} =0V		0.1	1.0	μA
V _{OUT}	Output Voltage	V _{IN} =V _{OUT} +3.0V, I _{OUT} =1mA	×0.98		×1.02	V
I _{OUT}	Output Current	V _{IN} =V _{OUT} +3.0V	50			mA
ΔV _{OUT} /ΔI _{OUT}	Load Regulation	V _{IN} =V _{OUT} +3.0V, 1mA ≤ I _{OUT} ≤ 40mA	Refer to the following table			
ΔV _{OUT} /ΔV _{IN}	Line Regulation	V _{OUT} +1.5V ≤ V _{IN} ≤ 36V, I _{OUT} =1mA		0.05	0.20	%/V
V _{DIF}	Dropout Voltage	I _{OUT} =20mA	Refer to the following table			
ΔV _{OUT} /ΔT _{opt}	Output Voltage Temperature Coefficient	V _{IN} =V _{OUT} +3.0V, I _{OUT} =1mA −40°C ≤ T _{opt} ≤ 105°C		±100		ppm/°C
I _{lim}	Short Current Limit	V _{OUT} =0V		45		mA
V _{CEH}	CE Input Voltage "H"		1.5		V _{IN}	V
V _{CEL}	CE Input Voltage "L"		0		0.3	V
T _{TSD}	Thermal Shutdown Temperature	Junction Temperature		150		°C
T _{TSR}	Thermal Shutdown Released Temperature	Junction Temperature		125		°C

• Load Regulation by Output Voltage

T_{opt}=25°C

Output Voltage V _{OUT} (V)	Load Regulation ΔV _{OUT} /ΔI _{OUT} (mV)		
	Conditions	Typ.	Max.
2.0 ≤ V _{OUT} < 5.0	V _{IN} =V _{OUT} +3.0V 1mA ≤ I _{OUT} ≤ 40mA	10	25
5.0 ≤ V _{OUT} ≤ 12.0		20	35

• Dropout Voltage by Output Voltage

T_{opt}=25°C

Output Voltage V _{OUT} (V)	Dropout Voltage V _{DIF} (V)		
	Condition	Typ.	Max.
2.0 ≤ V _{OUT} < 2.5	I _{OUT} =20mA	0.60	1.20
2.5 ≤ V _{OUT} < 3.0		0.40	0.85
3.0 ≤ V _{OUT} < 4.0		0.35	0.60
4.0 ≤ V _{OUT} < 5.0		0.25	0.40
5.0 ≤ V _{OUT} ≤ 12.0		0.20	0.35

TYPICAL APPLICATION

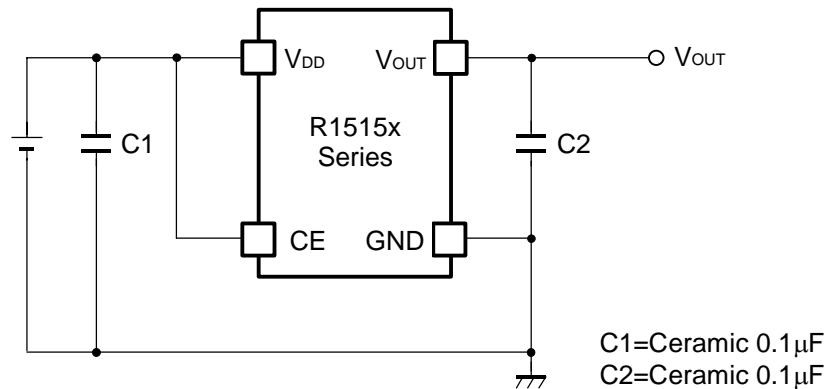

TECHNICAL NOTES

When using these ICs, consider the following points:

Phase Compensation

Phase Compensation of the R1515x Series has been made internally for stable operation even though the load current would vary. Therefore, without the capacitors, C1 and C2, the output voltage is regulated, however, for more stable operation, use capacitors as C1 and C2. Especially, if the input line is long and impedance is high, C1 is necessary. Moreover, if you use rather large C2, transient response will be improved. Recommended value is in the range from 0.1µF to 10µF. Wiring should be made as short as possible.

Connect the capacitor, C1 between V_{DD} pin and GND pin and C2 between V_{OUT} and GND as close as possible.

GND wiring of mounting on board

No.2 pin and No.4 pin of SOT-89-5 package must be wired to the GND plane. No.2 pin, No.4 pin and No.5 pin of HSOP-6J package must be wired to the GND plane when it is mounted on board.

Thermal Shutdown

Thermal shutdown function is included in the R1515x Series, if the junction temperature is equal or more than +150°C (Typ.), the operation of regulator would stop. After that, when the junction temperature is equal or less than +125°C (Typ.), the operation of regulator would restart. Unless the cause of rising temperature would remove, the regulator repeats on and off, and output waveform would be like consecutive pulses.

Chip Enable Circuit

Do not make voltage level of chip enable pin keep floating level, or in between V_{CEH} and V_{CEL}. Otherwise, the output voltage would be unstable or indefinite, or unexpected current would flow internally.

TEST CIRCUITS

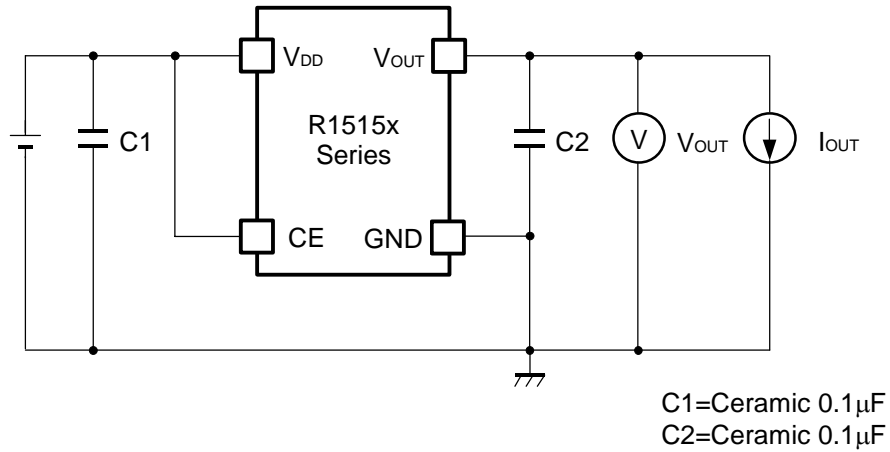

Basic Test Circuit

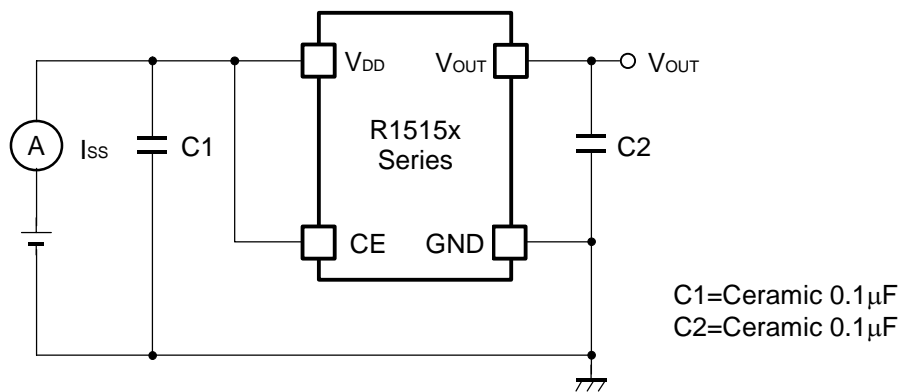

Test Circuit for Supply Current

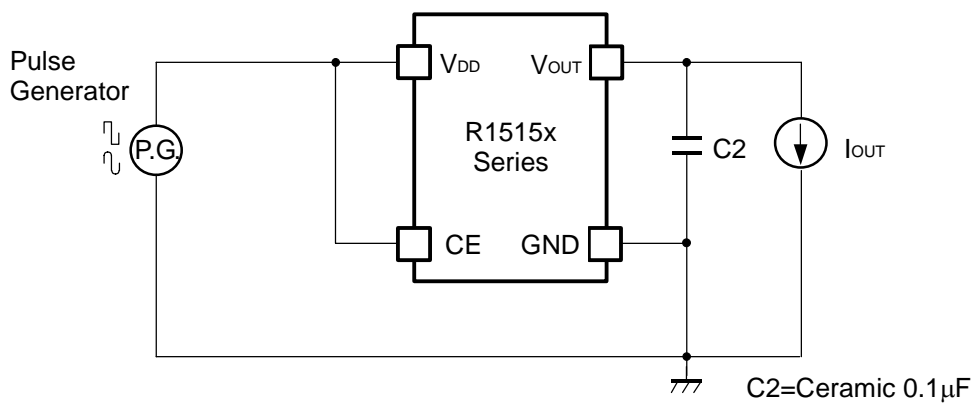

Test Circuit for Line Transient Response

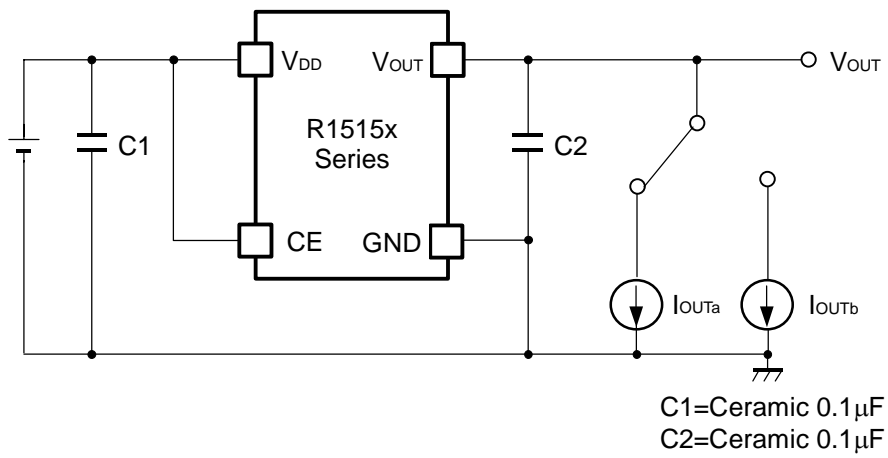

Test Circuit for Load Transient Response

TYPICAL CHARACTERISTICS

1) Output Voltage vs. Output Current (Topt=25°C)

R1515x020B

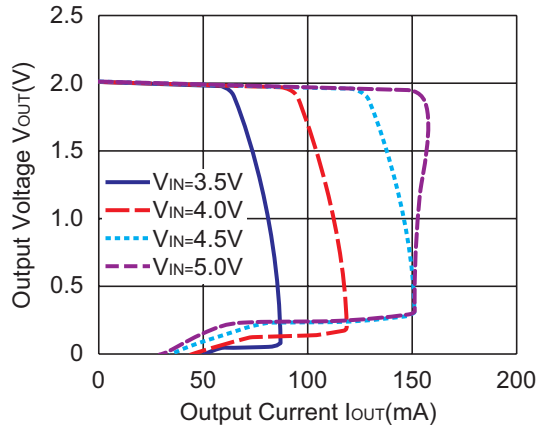

R1515x030B

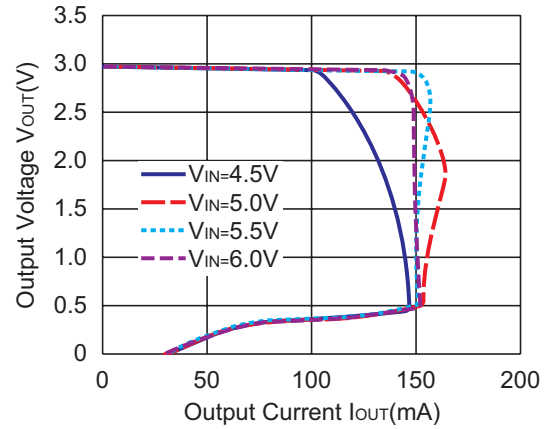

R1515x050B

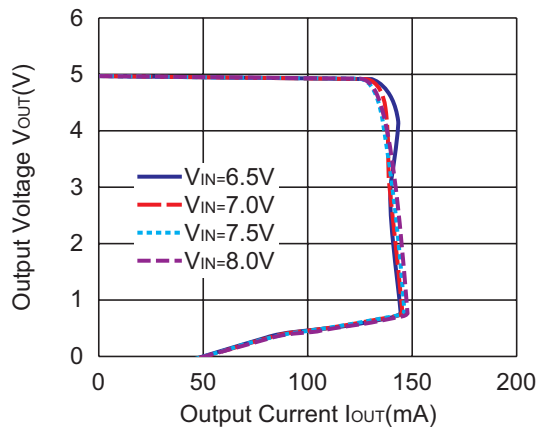

R1515x090B

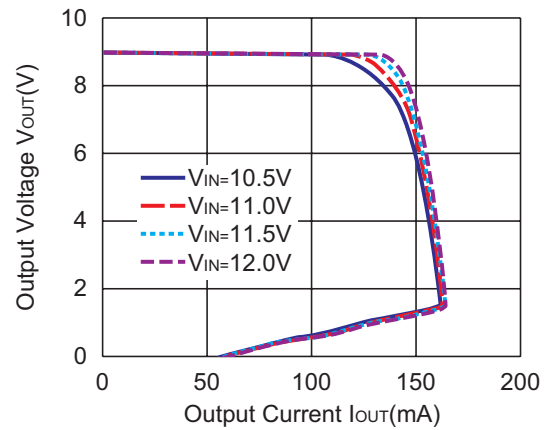

2) Output Voltage vs. Input Voltage (Topt=25°C)

R1515x020B

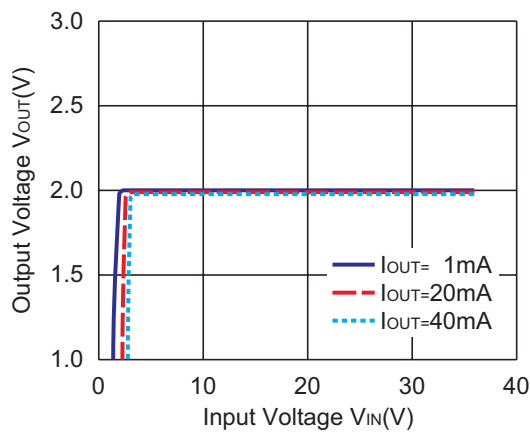

R1515x030B

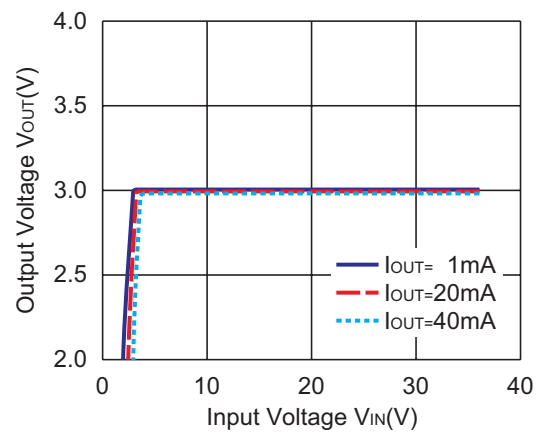

R1515x050B

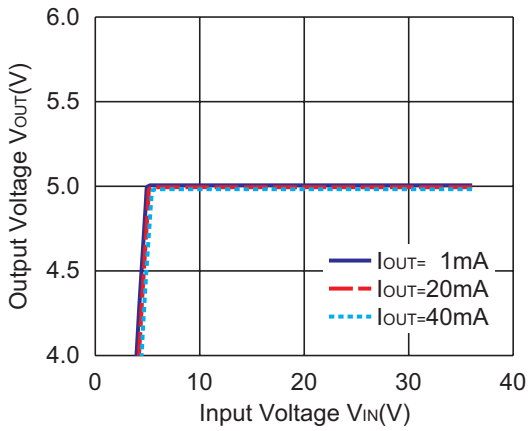

R1515x090B

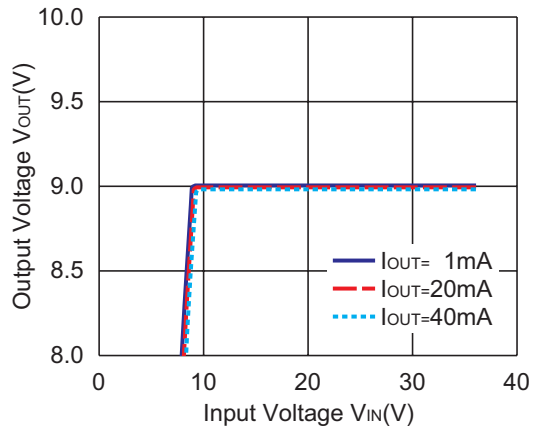

3) Dropout Voltage vs. Output Current

R1515x020B

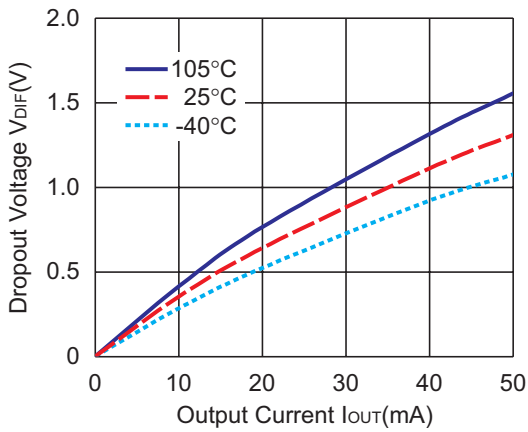

R1515x030B

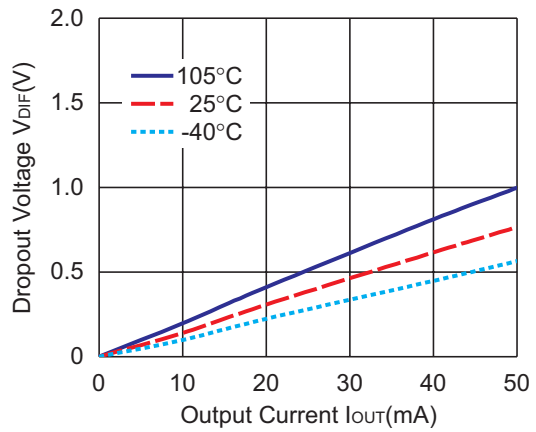

R1515x050B

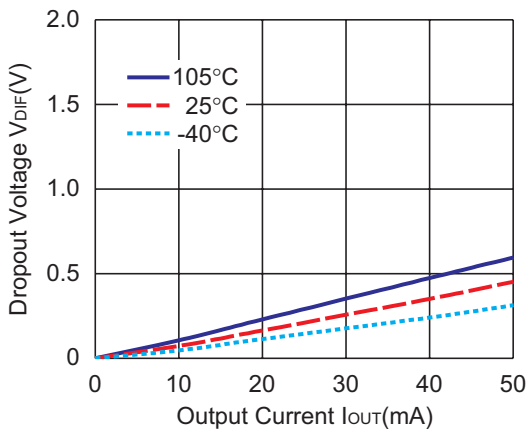

R1515x090B

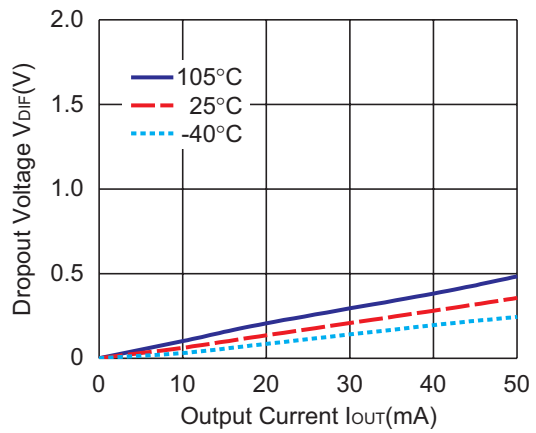

4) Output Voltage vs. Temperature

R1515x020B

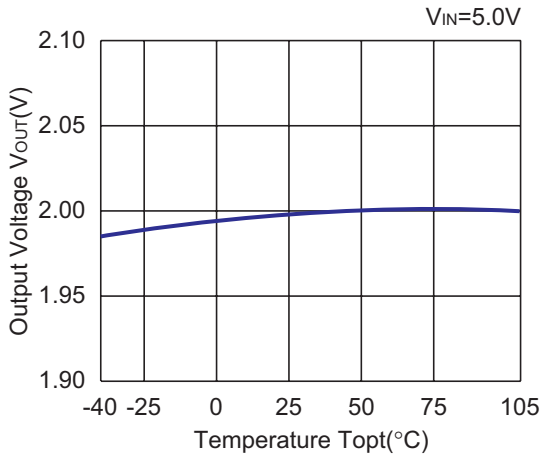

R1515x030B

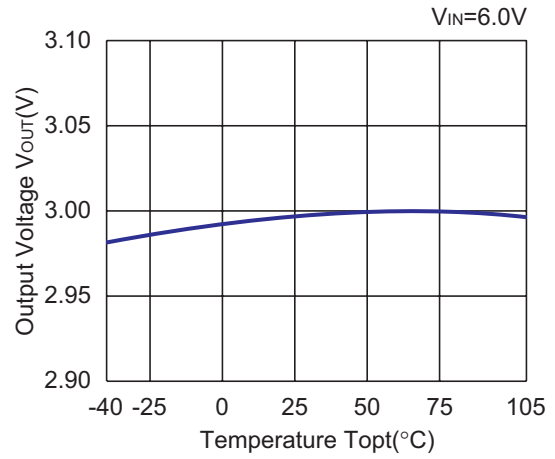

R1515x050B

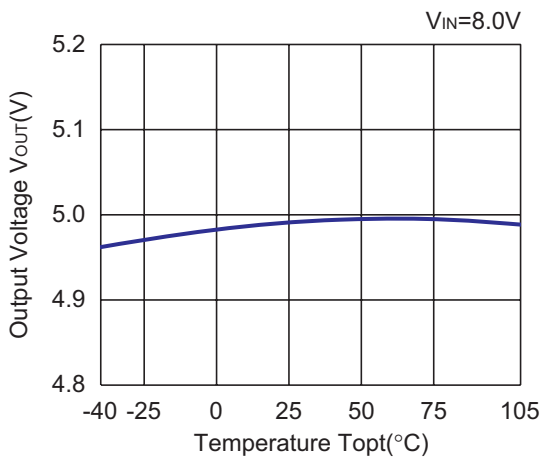

R1515x090B

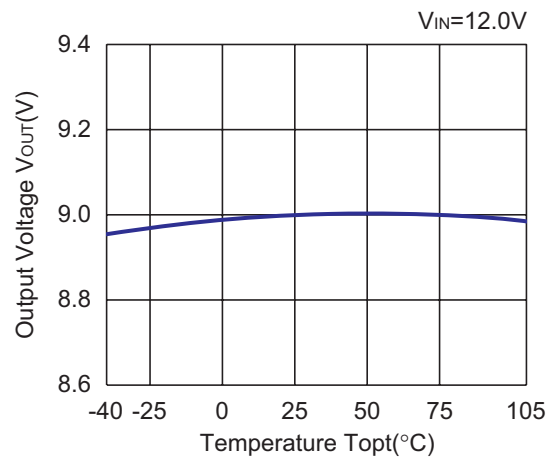

5) Supply Current vs. Input Voltage ($T_{opt}=25^{\circ}C$)

R1515x020B

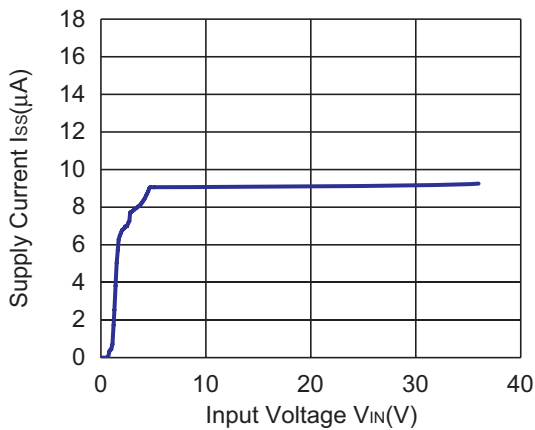

R1515x030B

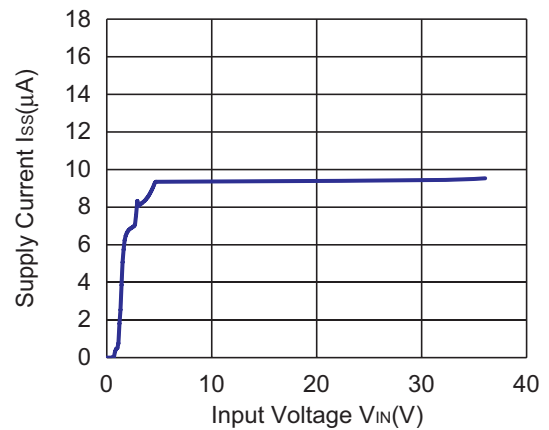

R1515x050B

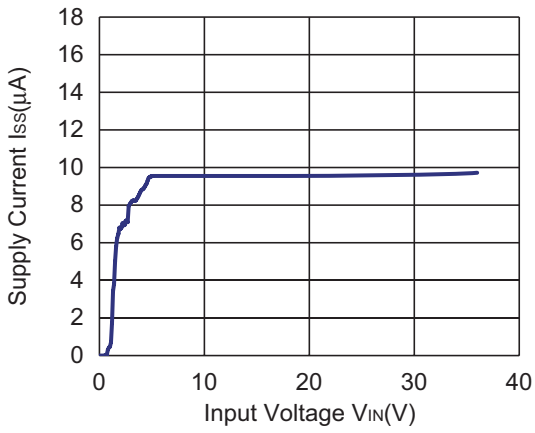

R1515x090B

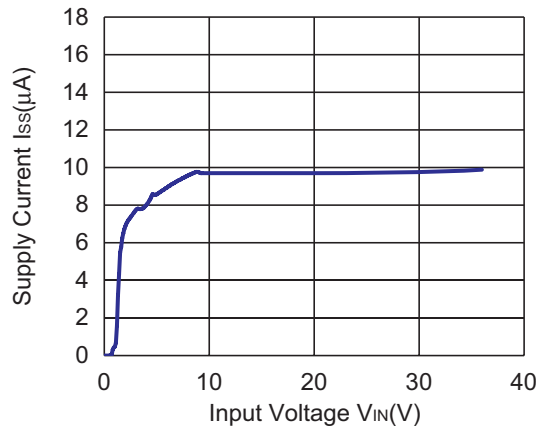

6) Supply Current vs. Temperature

R1515x020B

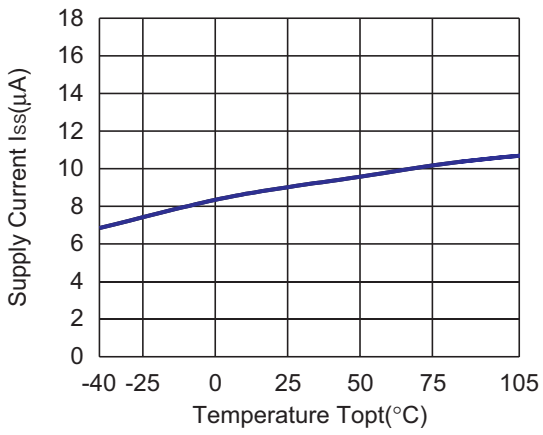

R1515x030B

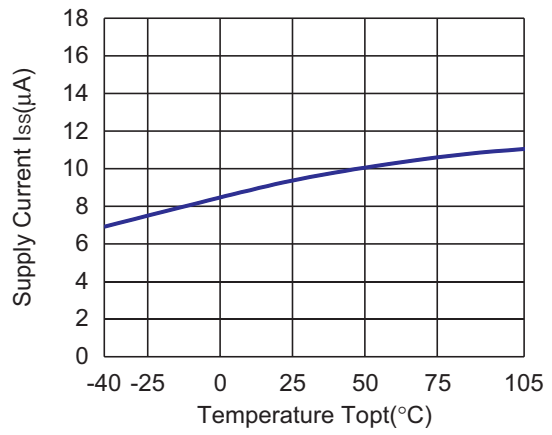

R1515x050B

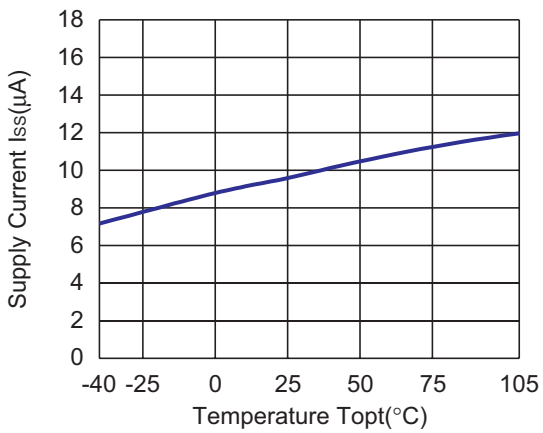

R1515x090B

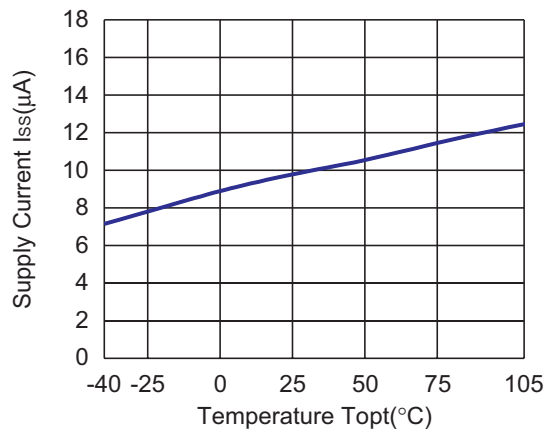

7) Input Transient Response ($I_{OUT}=1mA$, $t_r=t_f=50\mu s$, $C_2=Ceramic\ 0.1\mu F$, $T_{opt}=25^\circ C$)

R1515x020B

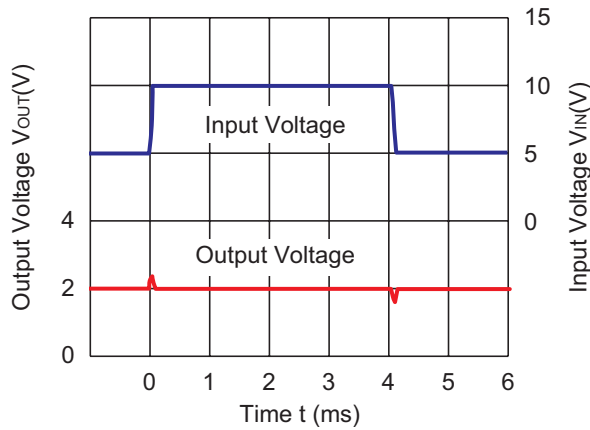

R1515x030B

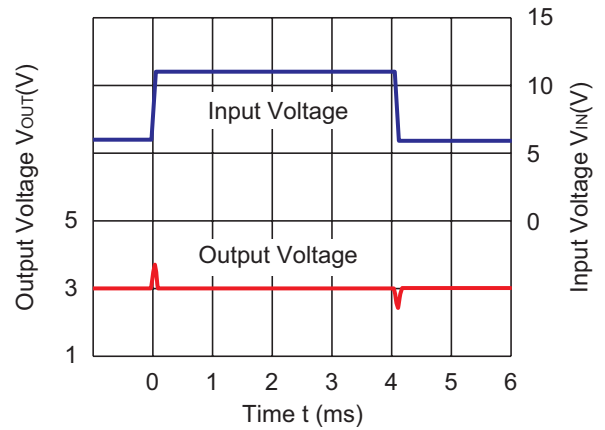

R1515x050B

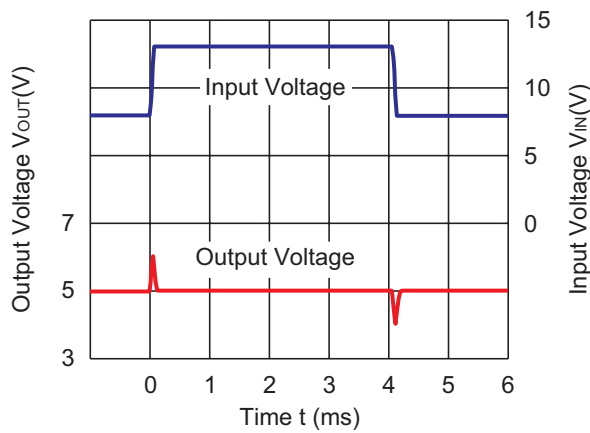

R1515x090B

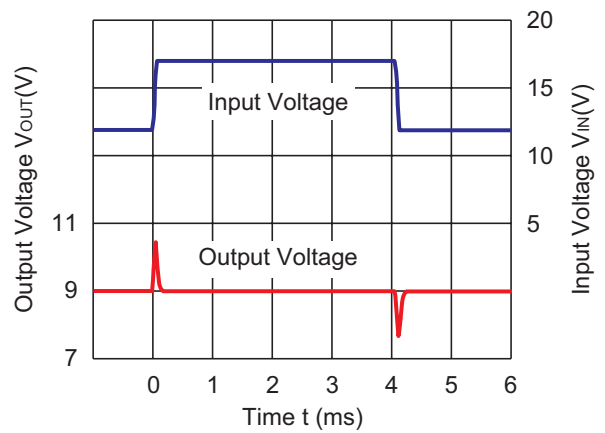

8) Load Transient Response ($C_2= Ceramic\ 0.1\mu F$, $T_{opt}=25^\circ C$)

R1515x020B

$V_{IN}=5.0V$
 $t_r=t_f=50\mu s$

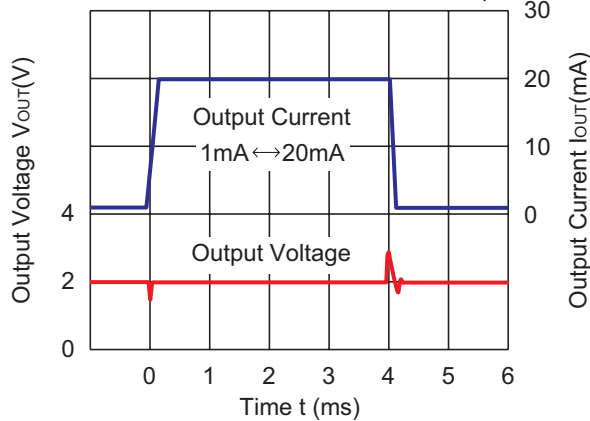

R1515x030B

$V_{IN}=6.0V$
 $t_r=t_f=50\mu s$

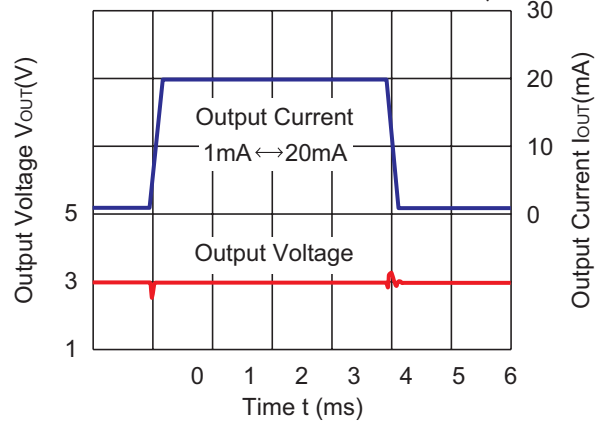

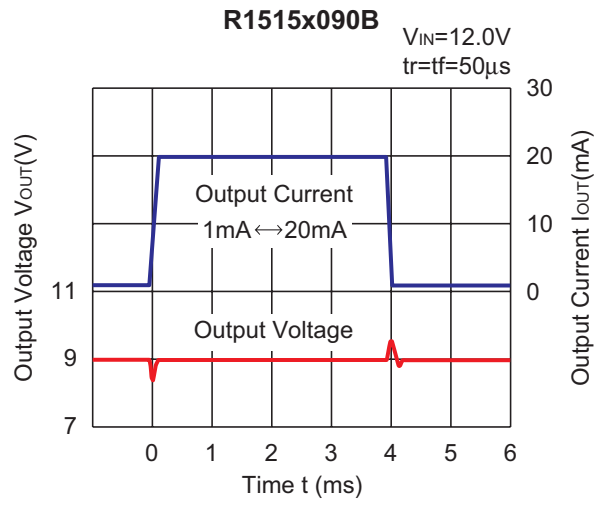
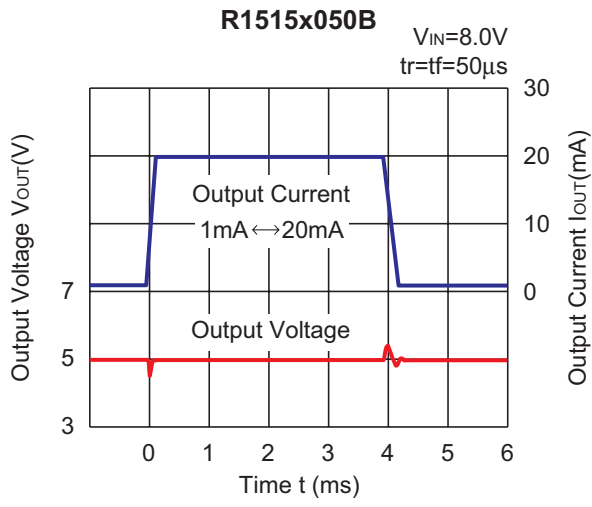

• SOT-89-5

Unit: mm

PACKAGE DIMENSIONS

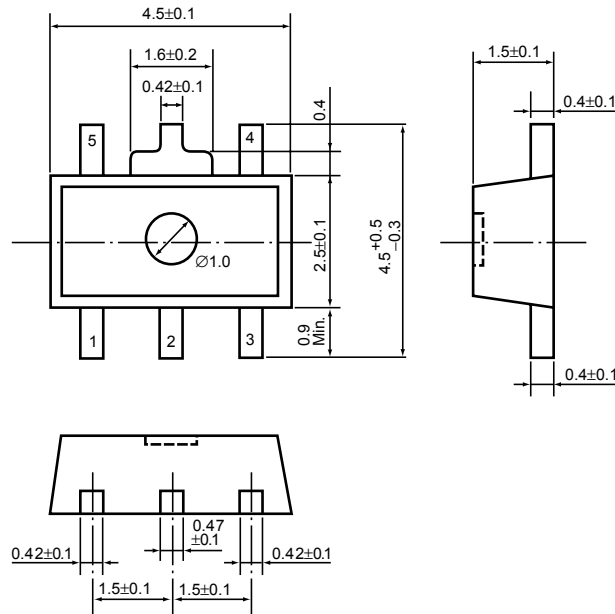

TAPING SPECIFICATION (T1: Standard Type)

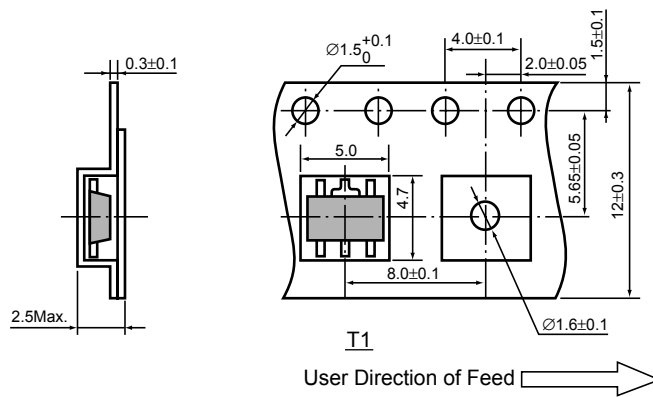

TAPING REEL DIMENSIONS REUSE REEL (EIAJ-RRM-12Bc)

(1reel=1000pcs)

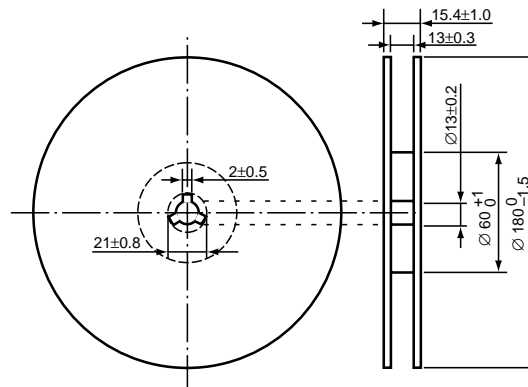

POWER DISSIPATION (SOT-89-5)

This specification is at mounted on board. Power Dissipation (P_D) depends on conditions of mounting on board. This specification is based on the measurement at the condition below:

Measurement Conditions

	High Wattage Land Pattern	Standard Land Pattern
Environment	Mounting on Board (Wind velocity=0m/s)	Mounting on Board (Wind velocity=0m/s)
Board Material	Glass cloth epoxy plastic (Double sided)	Glass cloth epoxy plastic (Double sided)
Board Dimensions	30mm × 30mm × 1.6mm	50mm × 50mm × 1.6mm
Copper Ratio	Top side : Approx. 20% , Back side : Approx. 100%	Top side : Approx. 10% , Back side : Approx. 100%
Through-hole	φ0.85mm × 10pcs	-

Measurement Result

($T_{opt}=25^{\circ}C, T_{jmax}=125^{\circ}C$)

	High Wattage Land Pattern	Standard Land Pattern	Free Air
Power Dissipation	1300mW	900mW	500mW
Thermal Resistance	77°C/W	111°C/W	200°C/W

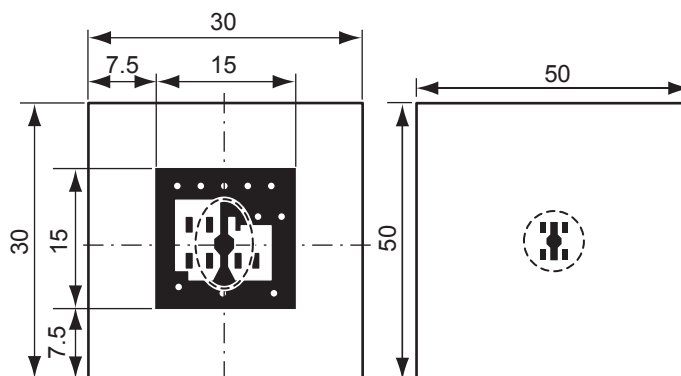
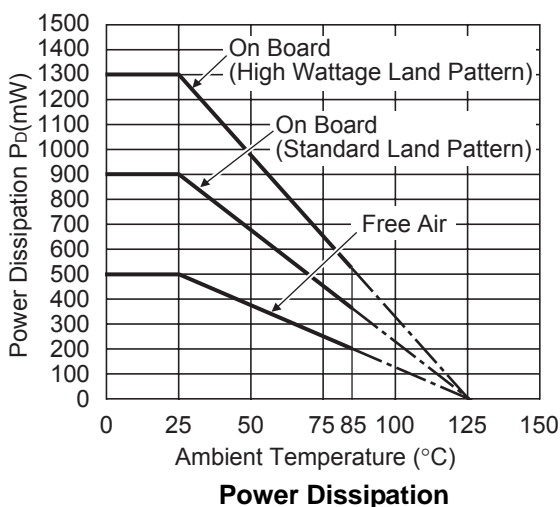

High Wattage Standard

Measurement Board Pattern

○ IC Mount Area (Unit : mm)

RECOMMENDED LAND PATTERN (SOT-89-5)

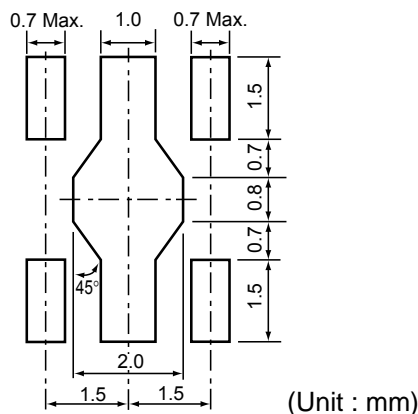

(Unit : mm)

• HSOP-6J

Unit: mm

PACKAGE DIMENSIONS

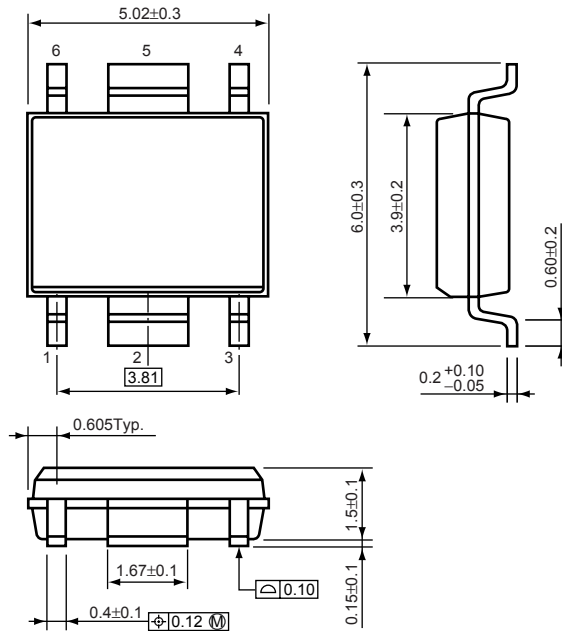

TAPING SPECIFICATION

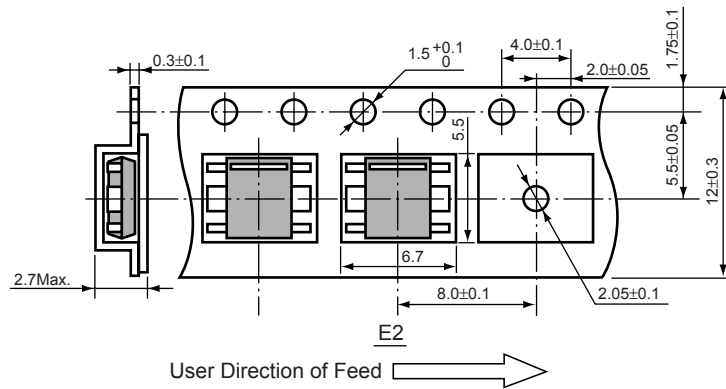

TAPING REEL DIMENSIONS REUSE REEL (EIAJ-RRM-12Bc)

(1reel=1000pcs)

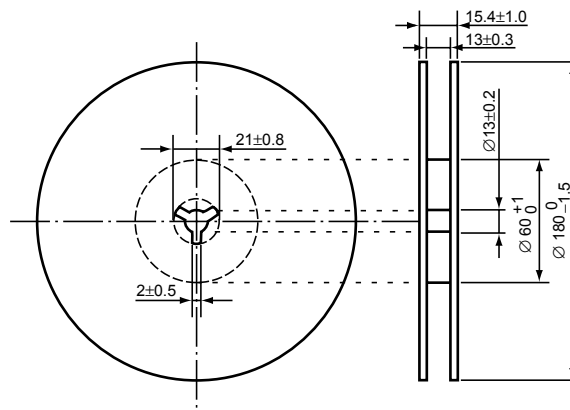

POWER DISSIPATION (HSOP-6J)

This specification is at mounted on board. Power Dissipation (P_D) depends on conditions of mounting on board. This specification is based on the measurement at the condition below:

Measurement Conditions

	High Wattage Land Pattern	Standard Land Pattern
Environment	Mounting on Board (Wind velocity=0m/s)	Mounting on Board (Wind velocity=0m/s)
Board Material	Glass cloth epoxy plactic (Double sided)	Glass cloth epoxy plactic (Double sided)
Board Dimensions	50mm × 50mm × 1.6mm	50mm × 50mm × 1.6mm
Copper Ratio	90%	50%
Through-hole	φ0.5mm × 44pcs	φ0.5mm × 44pcs

Measurement Result

($T_{opt}=25^{\circ}C, T_{jmax}=125^{\circ}C$)

	High Wattage Land Pattern	Standard Land Pattern	Free Air
Power Dissipation	2000mW	1700mW	540mW
Thermal Resistance	50°C/W	59°C/W	185°C/W

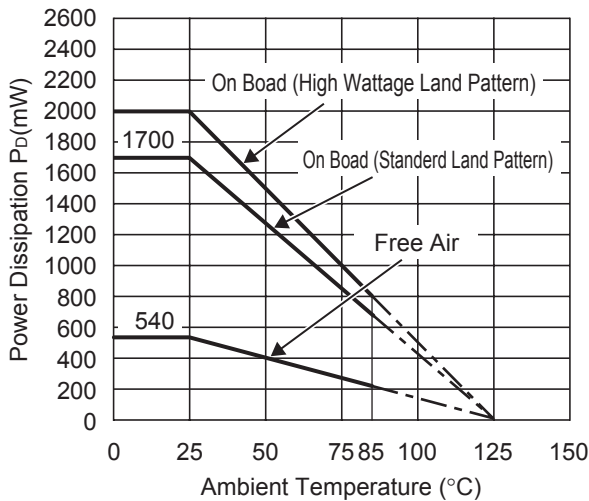

Power Dissipation

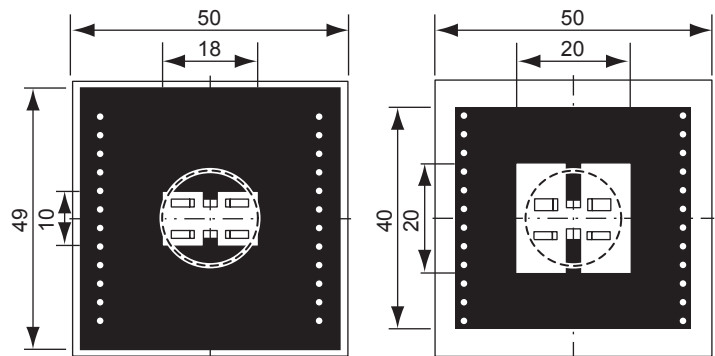

High Wattage

Standard

Measurement Board Pattern

○ IC Mount Area Unit : mm

RECOMMENDED LAND PATTERN (HSOP-6J)

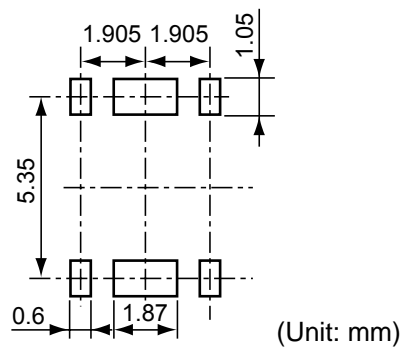

(Unit: mm)

R1515H SERIES MARK SPECIFICATION

• SOT-89-5

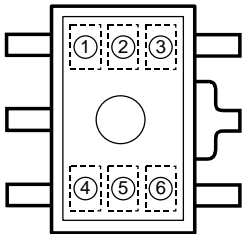

- ① : N (fixed)
- ②, ③, ④ : Setting Voltage } (Refer to Part Number vs. Product Code)
- ⑤, ⑥ : Lot Number

• Part Number vs. Product Code

Part Number	Product Code			
	①	②	③	④
R1515H020B	N	0	2	0
R1515H021B	N	0	2	1
R1515H022B	N	0	2	2
R1515H023B	N	0	2	3
R1515H024B	N	0	2	4
R1515H025B	N	0	2	5
R1515H026B	N	0	2	6
R1515H027B	N	0	2	7
R1515H028B	N	0	2	8
R1515H029B	N	0	2	9
R1515H030B	N	0	3	0
R1515H031B	N	0	3	1
R1515H032B	N	0	3	2
R1515H033B	N	0	3	3
R1515H034B	N	0	3	4
R1515H035B	N	0	3	5
R1515H036B	N	0	3	6
R1515H037B	N	0	3	7
R1515H038B	N	0	3	8
R1515H039B	N	0	3	9
R1515H040B	N	0	4	0
R1515H041B	N	0	4	1
R1515H042B	N	0	4	2
R1515H043B	N	0	4	3
R1515H044B	N	0	4	4
R1515H045B	N	0	4	5
R1515H046B	N	0	4	6
R1515H047B	N	0	4	7
R1515H048B	N	0	4	8
R1515H049B	N	0	4	9

Part Number	Product Code			
	①	②	③	④
R1515H050B	N	0	5	0
R1515H051B	N	0	5	1
R1515H052B	N	0	5	2
R1515H053B	N	0	5	3
R1515H054B	N	0	5	4
R1515H055B	N	0	5	5
R1515H056B	N	0	5	6
R1515H057B	N	0	5	7
R1515H058B	N	0	5	8
R1515H059B	N	0	5	9
R1515H060B	N	0	6	0
R1515H061B	N	0	6	1
R1515H062B	N	0	6	2
R1515H063B	N	0	6	3
R1515H064B	N	0	6	4
R1515H065B	N	0	6	5
R1515H066B	N	0	6	6
R1515H067B	N	0	6	7
R1515H068B	N	0	6	8
R1515H069B	N	0	6	9
R1515H070B	N	0	7	0
R1515H071B	N	0	7	1
R1515H072B	N	0	7	2
R1515H073B	N	0	7	3
R1515H074B	N	0	7	4
R1515H075B	N	0	7	5
R1515H076B	N	0	7	6
R1515H077B	N	0	7	7
R1515H078B	N	0	7	8
R1515H079B	N	0	7	9

Part Number	Product Code			
	①	②	③	④
R1515H080B	N	0	8	0
R1515H081B	N	0	8	1
R1515H082B	N	0	8	2
R1515H083B	N	0	8	3
R1515H084B	N	0	8	4
R1515H085B	N	0	8	5
R1515H086B	N	0	8	6
R1515H087B	N	0	8	7
R1515H088B	N	0	8	8
R1515H089B	N	0	8	9
R1515H090B	N	0	9	0
R1515H091B	N	0	9	1
R1515H092B	N	0	9	2
R1515H093B	N	0	9	3
R1515H094B	N	0	9	4
R1515H095B	N	0	9	5
R1515H096B	N	0	9	6
R1515H097B	N	0	9	7
R1515H098B	N	0	9	8
R1515H099B	N	0	9	9
R1515H100B	N	1	0	0
R1515H101B	N	1	0	1
R1515H102B	N	1	0	2
R1515H103B	N	1	0	3
R1515H104B	N	1	0	4
R1515H105B	N	1	0	5
R1515H106B	N	1	0	6
R1515H107B	N	1	0	7
R1515H108B	N	1	0	8
R1515H109B	N	1	0	9

Part Number	Product Code			
	①	②	③	④
R1515H110B	N	1	1	0
R1515H111B	N	1	1	1
R1515H112B	N	1	1	2
R1515H113B	N	1	1	3
R1515H114B	N	1	1	4
R1515H115B	N	1	1	5
R1515H116B	N	1	1	6
R1515H117B	N	1	1	7
R1515H118B	N	1	1	8
R1515H119B	N	1	1	9
R1515H120B	N	1	2	0

R1515S SERIES MARK SPECIFICATION

● HSOP-6J

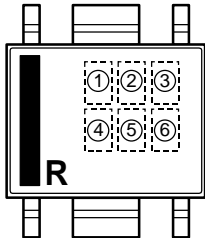

- ① : F (fixed)
- ②, ③, ④ : Setting Voltage } (Refer to Part Number vs. Product Code)
- ⑤, ⑥ : Lot Number

● Part Number vs. Product Code

Part Number	Product Code			
	①	②	③	④
R1515S020B	F	0	2	0
R1515S021B	F	0	2	1
R1515S022B	F	0	2	2
R1515S023B	F	0	2	3
R1515S024B	F	0	2	4
R1515S025B	F	0	2	5
R1515S026B	F	0	2	6
R1515S027B	F	0	2	7
R1515S028B	F	0	2	8
R1515S029B	F	0	2	9
R1515S030B	F	0	3	0
R1515S031B	F	0	3	1
R1515S032B	F	0	3	2
R1515S033B	F	0	3	3
R1515S034B	F	0	3	4
R1515S035B	F	0	3	5
R1515S036B	F	0	3	6
R1515S037B	F	0	3	7
R1515S038B	F	0	3	8
R1515S039B	F	0	3	9
R1515S040B	F	0	4	0
R1515S041B	F	0	4	1
R1515S042B	F	0	4	2
R1515S043B	F	0	4	3
R1515S044B	F	0	4	4
R1515S045B	F	0	4	5
R1515S046B	F	0	4	6
R1515S047B	F	0	4	7
R1515S048B	F	0	4	8
R1515S049B	F	0	4	9

Part Number	Product Code			
	①	②	③	④
R1515S050B	F	0	5	0
R1515S051B	F	0	5	1
R1515S052B	F	0	5	2
R1515S053B	F	0	5	3
R1515S054B	F	0	5	4
R1515S055B	F	0	5	5
R1515S056B	F	0	5	6
R1515S057B	F	0	5	7
R1515S058B	F	0	5	8
R1515S059B	F	0	5	9
R1515S060B	F	0	6	0
R1515S061B	F	0	6	1
R1515S062B	F	0	6	2
R1515S063B	F	0	6	3
R1515S064B	F	0	6	4
R1515S065B	F	0	6	5
R1515S066B	F	0	6	6
R1515S067B	F	0	6	7
R1515S068B	F	0	6	8
R1515S069B	F	0	6	9
R1515S070B	F	0	7	0
R1515S071B	F	0	7	1
R1515S072B	F	0	7	2
R1515S073B	F	0	7	3
R1515S074B	F	0	7	4
R1515S075B	F	0	7	5
R1515S076B	F	0	7	6
R1515S077B	F	0	7	7
R1515S078B	F	0	7	8
R1515S079B	F	0	7	9

Part Number	Product Code			
	①	②	③	④
R1515S080B	F	0	8	0
R1515S081B	F	0	8	1
R1515S082B	F	0	8	2
R1515S083B	F	0	8	3
R1515S084B	F	0	8	4
R1515S085B	F	0	8	5
R1515S086B	F	0	8	6
R1515S087B	F	0	8	7
R1515S088B	F	0	8	8
R1515S089B	F	0	8	9
R1515S090B	F	0	9	0
R1515S091B	F	0	9	1
R1515S092B	F	0	9	2
R1515S093B	F	0	9	3
R1515S094B	F	0	9	4
R1515S095B	F	0	9	5
R1515S096B	F	0	9	6
R1515S097B	F	0	9	7
R1515S098B	F	0	9	8
R1515S099B	F	0	9	9
R1515S100B	F	1	0	0
R1515S101B	F	1	0	1
R1515S102B	F	1	0	2
R1515S103B	F	1	0	3
R1515S104B	F	1	0	4
R1515S105B	F	1	0	5
R1515S106B	F	1	0	6
R1515S107B	F	1	0	7
R1515S108B	F	1	0	8
R1515S109B	F	1	0	9

Part Number	Product Code			
	①	②	③	④
R1515S110B	F	1	1	0
R1515S111B	F	1	1	1
R1515S112B	F	1	1	2
R1515S113B	F	1	1	3
R1515S114B	F	1	1	4
R1515S115B	F	1	1	5
R1515S116B	F	1	1	6
R1515S117B	F	1	1	7
R1515S118B	F	1	1	8
R1515S119B	F	1	1	9
R1515S120B	F	1	2	0

Компания «Океан Электроники» предлагает заключение долгосрочных отношений при поставках импортных электронных компонентов на взаимовыгодных условиях!

Наши преимущества:

- Поставка оригинальных импортных электронных компонентов напрямую с производств Америки, Европы и Азии, а так же с крупнейших складов мира;
- Широкая линейка поставок активных и пассивных импортных электронных компонентов (более 30 млн. наименований);
- Поставка сложных, дефицитных, либо снятых с производства позиций;
- Оперативные сроки поставки под заказ (от 5 рабочих дней);
- Экспресс доставка в любую точку России;
- Помощь Конструкторского Отдела и консультации квалифицированных инженеров;
- Техническая поддержка проекта, помощь в подборе аналогов, поставка прототипов;
- Поставка электронных компонентов под контролем ВП;
- Система менеджмента качества сертифицирована по Международному стандарту ISO 9001;
- При необходимости вся продукция военного и аэрокосмического назначения проходит испытания и сертификацию в лаборатории (по согласованию с заказчиком);
- Поставка специализированных компонентов военного и аэрокосмического уровня качества (Xilinx, Altera, Analog Devices, Intersil, Interpoint, Microsemi, Actel, Aeroflex, Peregrine, VPT, Syfer, Eurofarad, Texas Instruments, MS Kennedy, Miteq, Cobham, E2V, MA-COM, Hittite, Mini-Circuits, General Dynamics и др.);

Компания «Океан Электроники» является официальным дистрибьютором и эксклюзивным представителем в России одного из крупнейших производителей разъемов военного и аэрокосмического назначения «JONHON», а так же официальным дистрибьютором и эксклюзивным представителем в России производителя высокотехнологичных и надежных решений для передачи СВЧ сигналов «FORSTAR».



JONHON

«JONHON» (основан в 1970 г.)

Разъемы специального, военного и аэрокосмического назначения:

(Применяются в военной, авиационной, аэрокосмической, морской, железнодорожной, горно- и нефтедобывающей отраслях промышленности)

«FORSTAR» (основан в 1998 г.)

ВЧ соединители, коаксиальные кабели, кабельные сборки и микроволновые компоненты:

(Применяются в телекоммуникациях гражданского и специального назначения, в средствах связи, РЛС, а так же военной, авиационной и аэрокосмической отраслях промышленности).



Телефон: 8 (812) 309-75-97 (многоканальный)

Факс: 8 (812) 320-03-32

Электронная почта: ocean@oceanchips.ru

Web: <http://oceanchips.ru/>

Адрес: 198099, г. Санкт-Петербург, ул. Калинина, д. 2, корп. 4, лит. А