



Piezo Haptic Actuator - PowerHap™

Type 15G

Series/Type:	PowerHap 15G - Prototypes
Ordering code:	Z63000Z2910Z 1Z 4
Date:	2017-07-28
Version:	9 – Preliminary data

© EPCOS AG 2017. Reproduction, publication and dissemination of this publication, enclosures hereto and the information contained therein without EPCOS' prior express consent is prohibited.

EPCOS AG is a TDK Group Company.

Preliminary data
Features

- Large displacement
- High acceleration
- High force
- Low insertion height
- Fast response time
- Integrated sensor functionality

Design

- RoHS-compatible PZT (lead zirconium titanate) ceramic
- Copper inner electrodes
- Dimension of ceramic body: 26 x 26 x 1 (mm)
- Titanium cymbals for displacement amplification
- Polarized at 120 V
- Contains SVHC substance 12626-81-2

Electrical ratings

Parameter	Ratings
Rated voltage	0 ... 120 V
Operating temperature powered	-40 ... +85 °C
Operating temperature unpowered	-40 ... +125 °C
Maximum compressive force on actuator	0 ... 20 N
Maximum operation frequency	500 Hz*
Maximum voltage gradient	1.2 MV/s

*) Operation frequency is limited by self-heating of the device. At 120 V, 500 Hz, square wave conditions, a maximum temperature increase of +30 °C is observed.

Electrical characteristics

Parameter	Conditions @ 25 °C	Expected value (typ.)
Capacitance; C	1 kHz, 1 V _{RMS}	3.6 μF
Dissipation factor; tan δ	1 kHz, 1 V _{RMS}	< 0.05
1 st Resonance frequency	0.5 V _{RMS}	8 kHz
Displacement; s	120 V, measured at cymbal end-caps	200 μm
Loading Energy; E = Q • U/2	120 V	41 mJ
Stiffness; k	120 V various load stiffness; preload 10 N	100 N/mm
Acceleration	load 20 g, square wave, 120 V	65 g
	load 100 g, square wave, 120 V	15 g
	load 500 g, square wave, 120 V	5.0 g

General

Polarity of the prototypes: “+” is the larger metallization area. In the preliminary phase, samples are delivered with soldered wires where the red wire is the positive pole

Preliminary data

Dimensional drawings

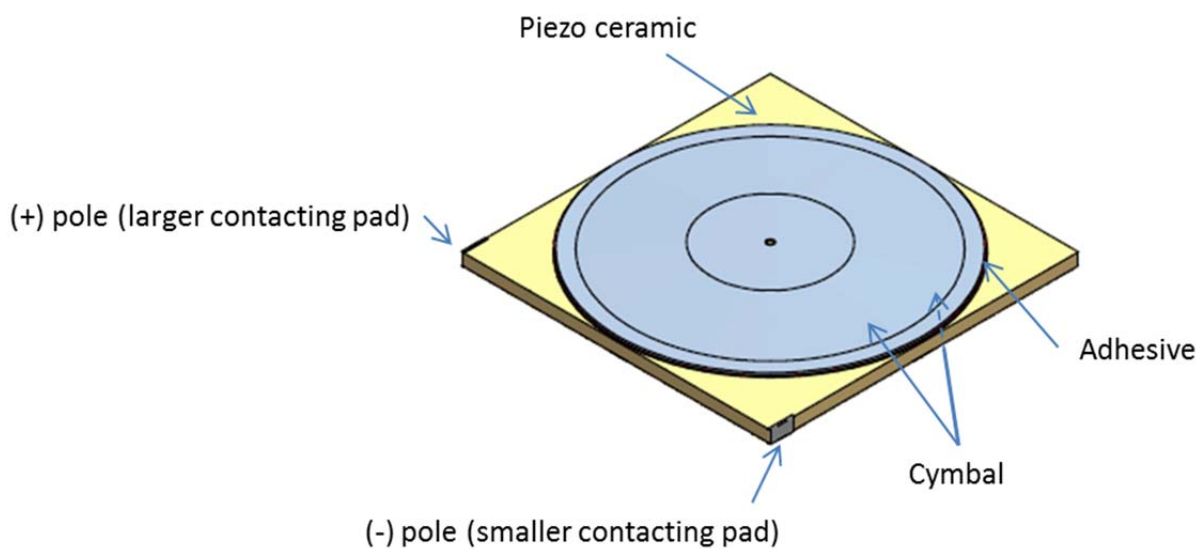
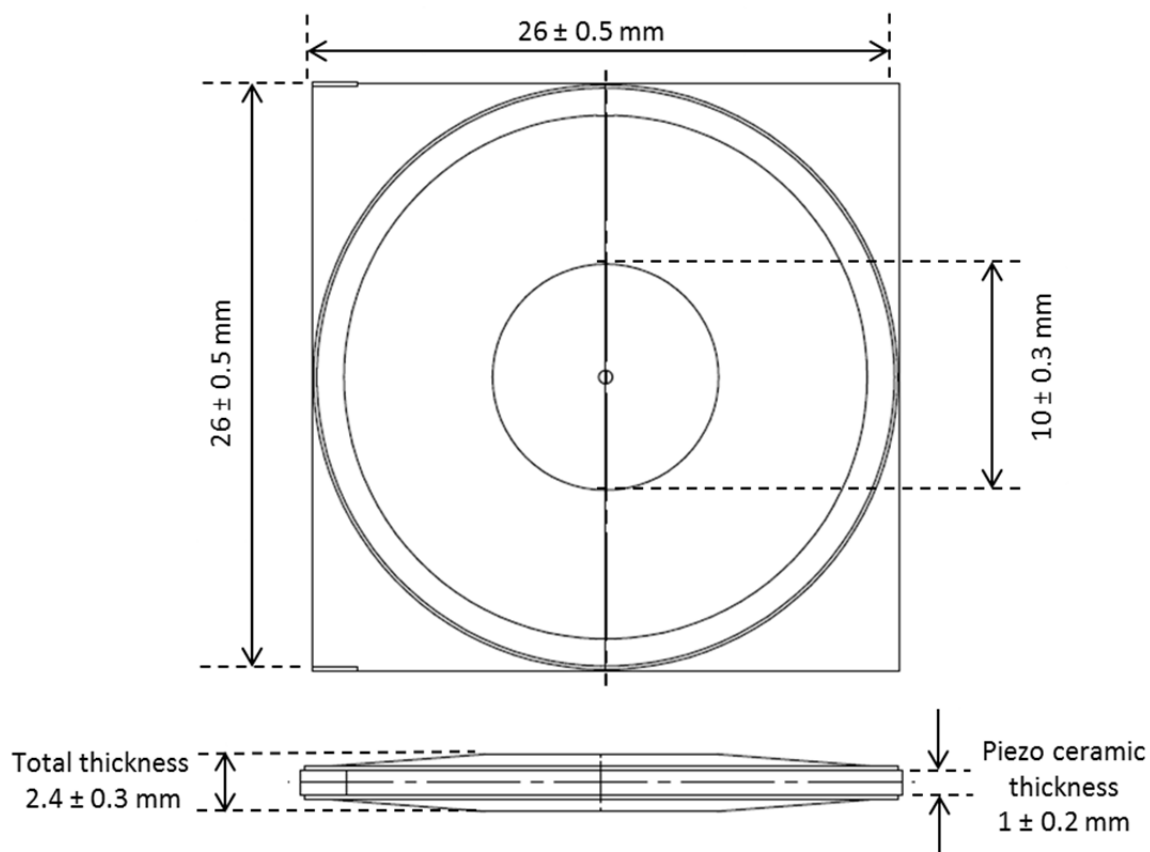

Preliminary data
Application note

Depending on the exact application and geometry PowerHap actuators can be mounted and operated in different ways. Some options shall be explained in more detail:

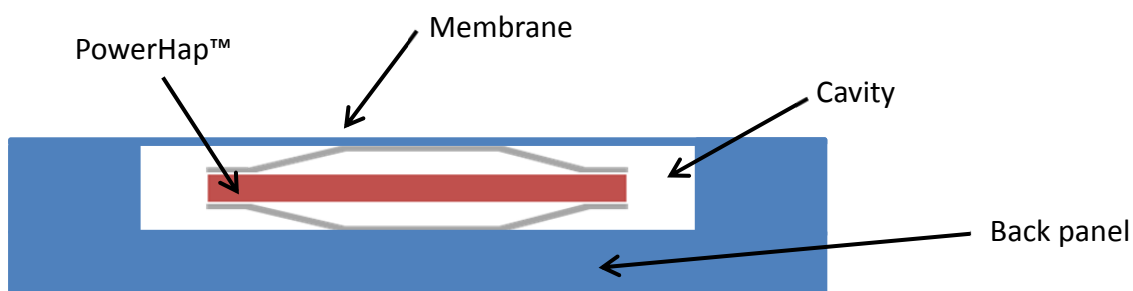
1) Mounting underneath a membrane

In this case the PowerHap actuator is clamped between a thin, flexible membrane and a rigid back panel. By applying a voltage, the actuator elongates and consequently deforms the membrane.

In principle the membrane can be out of any material, but it may be necessary to tune the thickness. While the membrane needs to be as flexible as possible to maximize the haptic feedback felt by the user, it needs to be also stiff enough to properly clamp the actuator.

In contrast, the back panel has to be as stiff as possible, so that only the membrane is the deformed. For optimal performance, it is further recommended that the actuator is compressed by a preload of 5 N up to maximum 20 N.

2) Direct mounting to a load

In some applications, for example if haptic feedback shall be applied to a touchscreen, the deformation of a membrane may be undesirable. In such cases PowerHap actuators can be mounted directly underneath the load (for example a touchscreen).

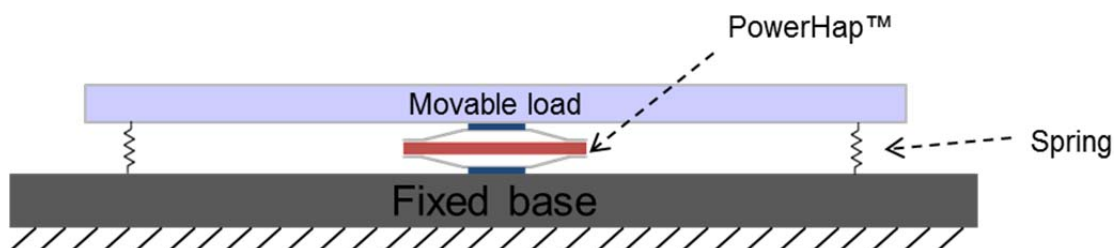

By applying a voltage to the actuator, it elongates and therefore moves the load. This movement can be felt by the user. For a maximal haptic feedback, the rear panel needs to be as heavy as possible. Otherwise the PowerHap actuator will not only move the load but also the rear panel and therefore a part of the performance is lost.

In the simplest case it is possible to press the load on the PowerHap actuator (and consequently also the PowerHap actuator to the rear panel) by using springs. As in case 1 a preload of 5 N up to maximum 20 N is recommended. To ensure the position of the PowerHap actuator, it can be either fixed to the rear panel or the load (e.g. adhesive tape, glue).

Preliminary data

3) Multiple actuators

PowerHap actuators are optimized to deliver a strong haptic feedback. For example, a test load with a mass of 0.1 kg is accelerated with up to 15 g. However, for heavier loads the acceleration decreases. As a consequence for very heavy loads (like huge displays) the user may only experience a very weak or even unnoticeable haptic effect. In such cases it is possible to combine multiple actuators.

General application notes

Some parts of this publication contain statements about the suitability of our ceramic piezo components for certain areas of application, including recommendations about incorporation/design-in of these products into customer applications. The statements are based on our knowledge of typical requirements made of our devices in the particular areas. We nevertheless expressly point out that such statements cannot be regarded as binding statements about the suitability of our piezo components for a particular customer application. As a rule, EPCOS is either unfamiliar with individual customer applications or less familiar with them than the customers themselves. For these reasons, it is always incumbent on the customer to check and decide whether the piezo component devices with the properties described in the product specification are suitable for use in a particular customer application.

- Do not use piezo components for purposes not identified in our specifications, application notes and data sheets.
- Ensure the suitability of a piezo component in particular by testing it for reliability during design-in. Always evaluate a piezo component under worst-case conditions.
- Pay special attention to the reliability of piezo devices intended for use in safety-critical applications (e.g. medical equipment, automotive, spacecraft, nuclear power plant).
- Do not drive the piezo actuator under resonance conditions.

Design notes

- Consider de-rating at higher operating temperatures and loads.
- In some cases the malfunctioning of passive electronic components or failure before the end of their service life cannot be completely ruled out in the current state of the art, even if they are operated as specified. In applications requiring a very high level of operational safety and especially when the malfunction or failure of a passive electronic component could endanger human life or health (e.g. in accident prevention, life-saving systems, or automotive battery line applications such as clamp 30), ensure by suitable design of the application or other measures (e.g. installation of protective circuitry or redundancy) that no injury or damage is sustained by third parties in the event of such a malfunction or failure. Do not use piezo components in safety-relevant applications.
- Specified values only apply to piezo components that have not been subject to prior electrical, mechanical or thermal damage.

Operation

- Use piezo actuator components only within the specified operating temperature range.
- Use piezo actuator components only within specified voltage and current ranges.
- Piezo actuator components have to be operated in a dry, non-reducing atmosphere which must not contain any additional chemical vapours or substances. We recommend appropriate drying of

Preliminary data

- all components prior to hermetically sealing.
- We recommend a preload of at least 5 N.
- Prevent a piezo actuator component from contacting liquids and solvents. Make sure that no water enters a piezo actuator component (e.g. through plug terminals).
- Avoid dewing and condensation.
- EPCOS piezo actuator components are mainly designed for encased applications. Under all circumstances avoid exposure to:
 - direct sunlight
 - rain or condensation
 - steam, saline spray
 - corrosive gases
 - atmosphere with reduced oxygen content.
- We expressly point out that in case of non-observance of the aforesaid notes, in particular due to reasons attributable to chemical vapours, a malfunction or failure of the piezo actuator components before the end of their usual service life cannot be completely ruled out, even if they are operated as specified.

Storage, handling and mounting instructions

Storage

- Store the piezo actuator component with terminals short-circuited.
- Avoid contamination of the piezo actuator component surface during storage.
- Avoid storage of the piezo actuator components in harmful environments where they are exposed to corrosive gases (e.g. SO_x, Cl).
- Storage conditions:
Storage temperature: -25 °C to +45 °C
Relative humidity (RH): ≤ 75% annual average, ≤ 95% on 30 days a year.
Dew precipitation is inadmissible.
- Process piezo actuator components within 12 months after shipment from EPCOS.

Handling

- Do not drop piezo actuator components or allow them to be chipped.
- Apply maximum force of 10 N at the component during handling.
- Do not touch piezo actuator component with bare hands, powderless nitrile gloves are recommended.
- Avoid contamination of the piezo actuator component surface during handling.

Mounting

- Make sure the surface of the leads is not scratched before, during or after the mounting process.
- Make sure contacts and housings used for assembly with piezo actuator components are clean and dry before mounting.
- Avoid contamination of the surface of the piezo actuator component during processing.

Preliminary data

- Make sure ceramic end surfaces are clean before mounting process. We recommend to short-circuit the piezo actuator component during the whole mounting process.

Cautions and warnings

The piezo component has to be operated in a dry, non-reducing, open environment and atmosphere which must not contain any chemical vapors or substances.

To prevent damages on the piezo component, tensile stresses must be avoided under all driving conditions.

We expressly point out that in case of non-observance of the aforesaid notes, in particular due to reasons attributable to chemical vapors, a malfunction of the piezo sample or failure before the end of their usual service life cannot be completely ruled out, even if they are operated as specified.

Depending on the individual application, piezo samples are electrically connected to voltages and currents, which are potentially dangerous for life and health of the operator. Installation and operation of piezo sample have to be done only by authorized personnel. Ensure proper and safe connections, couplers, and drivers.

Caution: Piezo component are highly efficient charge storing capacitors. Even when they are disconnected from a supply, the electrical energy content of a loaded actuator can be high and is held for a long time. Always ensure a complete discharging of an actuator (e.g. via a 10 kΩ resistor) before handling. (Do not discharge by simple short-circuiting, because of the risk of damaging the ceramic.)

Electrical charges can be generated on disconnected actuators by varying load or temperature. *Caution:* Discharge an actuator before connecting it to a measuring device/electronics, when this device is not sufficiently voltage proofed.

Remark

The products delivered are engineering samples, prototypes or pre-series products, which are not intended for commercial use in series products of the purchaser. EPCOS assumes no warranty for these products. Any use is at the sole risk of the purchaser.

Contains SVHC Substance 12626-81-2

Display of ordering codes for EPCOS products

The ordering code for one and the same EPCOS product can be represented differently in data sheets, data books, other publications, on the EPCOS website, or in order-related documents such as shipping notes, order confirmations and product labels. **The varying representations of the ordering codes are due to different processes employed and do not affect the specifications of the respective products.** Detailed information can be found on the Internet under www.epcos.com/orderingcodes

Important notes

The following applies to all products named in this publication:

1. Some parts of this publication contain **statements about the suitability of our products for certain areas of application**. These statements are based on our knowledge of typical requirements that are often placed on our products in the areas of application concerned. We nevertheless expressly point out **that such statements cannot be regarded as binding statements about the suitability of our products for a particular customer application**. As a rule, EPCOS is either unfamiliar with individual customer applications or less familiar with them than the customers themselves. For these reasons, it is always ultimately incumbent on the customer to check and decide whether an EPCOS product with the properties described in the product specification is suitable for use in a particular customer application.
2. We also point out that **in individual cases, a malfunction of electronic components or failure before the end of their usual service life cannot be completely ruled out in the current state of the art, even if they are operated as specified**. In customer applications requiring a very high level of operational safety and especially in customer applications in which the malfunction or failure of an electronic component could endanger human life or health (e.g. in accident prevention or life-saving systems), it must therefore be ensured by means of suitable design of the customer application or other action taken by the customer (e.g. installation of protective circuitry or redundancy) that no injury or damage is sustained by third parties in the event of malfunction or failure of an electronic component.
3. **The warnings, cautions and product-specific notes must be observed.**
4. In order to satisfy certain technical requirements, **some of the products described in this publication may contain substances subject to restrictions in certain jurisdictions (e.g. because they are classed as hazardous)**. Useful information on this will be found in our Material Data Sheets on the Internet (www.epcos.com/material). Should you have any more detailed questions, please contact our sales offices.
5. We constantly strive to improve our products. Consequently, **the products described in this publication may change from time to time**. The same is true of the corresponding product specifications. Please check therefore to what extent product descriptions and specifications contained in this publication are still applicable before or when you place an order. We also **reserve the right to discontinue production and delivery of products**. Consequently, we cannot guarantee that all products named in this publication will always be available. The aforementioned does not apply in the case of individual agreements deviating from the foregoing for customer-specific products.
6. Unless otherwise agreed in individual contracts, **all orders are subject to the current version of the "General Terms of Delivery for Products and Services in the Electrical Industry" published by the German Electrical and Electronics Industry Association (ZVEI)**.
7. The trade names EPCOS, CeraCharge, CeraDiode, CeraLink, CeraPad, CeraPlus, CSMP, CTVS, DeltaCap, DigiSiMic, ExoCore, FilterCap, FormFit, LeaXield, MiniBlue, MiniCell, MKD, MKK, MotorCap, PCC, PhaseCap, PhaseCube, PhaseMod, PhiCap, PowerHap, PQSine, PQvar, SIFERRIT, SIFI, SIKOREL, SilverCap, SIMDAD, SiMic, SIMID, SineFormer, SIOV, ThermoFuse, WindCap are **trademarks registered or pending** in Europe and in other countries. Further information will be found on the Internet at www.epcos.com/trademarks.

Mouser Electronics

Authorized Distributor

Click to View Pricing, Inventory, Delivery & Lifecycle Information:

[EPCOS / TDK:](#)

[Z63000Z2910Z1Z4](#) [Z63000Z2910Z1Z1](#) [Z63000Z2910Z1Z7](#)

Компания «Океан Электроники» предлагает заключение долгосрочных отношений при поставках импортных электронных компонентов на взаимовыгодных условиях!

Наши преимущества:

- Поставка оригинальных импортных электронных компонентов напрямую с производств Америки, Европы и Азии, а так же с крупнейших складов мира;
- Широкая линейка поставок активных и пассивных импортных электронных компонентов (более 30 млн. наименований);
- Поставка сложных, дефицитных, либо снятых с производства позиций;
- Оперативные сроки поставки под заказ (от 5 рабочих дней);
- Экспресс доставка в любую точку России;
- Помощь Конструкторского Отдела и консультации квалифицированных инженеров;
- Техническая поддержка проекта, помощь в подборе аналогов, поставка прототипов;
- Поставка электронных компонентов под контролем ВП;
- Система менеджмента качества сертифицирована по Международному стандарту ISO 9001;
- При необходимости вся продукция военного и аэрокосмического назначения проходит испытания и сертификацию в лаборатории (по согласованию с заказчиком);
- Поставка специализированных компонентов военного и аэрокосмического уровня качества (Xilinx, Altera, Analog Devices, Intersil, Interpoint, Microsemi, Actel, Aeroflex, Peregrine, VPT, Syfer, Eurofarad, Texas Instruments, MS Kennedy, Miteq, Cobham, E2V, MA-COM, Hittite, Mini-Circuits, General Dynamics и др.);

Компания «Океан Электроники» является официальным дистрибьютором и эксклюзивным представителем в России одного из крупнейших производителей разъемов военного и аэрокосмического назначения «JONHON», а так же официальным дистрибьютором и эксклюзивным представителем в России производителя высокотехнологичных и надежных решений для передачи СВЧ сигналов «FORSTAR».



JONHON

«JONHON» (основан в 1970 г.)

Разъемы специального, военного и аэрокосмического назначения:

(Применяются в военной, авиационной, аэрокосмической, морской, железнодорожной, горно- и нефтедобывающей отраслях промышленности)

«FORSTAR» (основан в 1998 г.)

ВЧ соединители, коаксиальные кабели, кабельные сборки и микроволновые компоненты:

(Применяются в телекоммуникациях гражданского и специального назначения, в средствах связи, РЛС, а так же военной, авиационной и аэрокосмической отраслях промышленности).



Телефон: 8 (812) 309-75-97 (многоканальный)

Факс: 8 (812) 320-03-32

Электронная почта: ocean@oceanchips.ru

Web: <http://oceanchips.ru/>

Адрес: 198099, г. Санкт-Петербург, ул. Калинина, д. 2, корп. 4, лит. А