

Guard Lock Safety-door Switch

D4BL

Protective Doors Are Locked Until Machines Completely Stop Operating

- A mechanical lock is applied automatically when the Operation Key is inserted. A high level of safety is achieved using a mechanism where the lock is only released when voltage is applied to the solenoid.
- Conforms to EN (TÜV) standards corresponding to the CE marking.
- Approved by UL, CSA, BIA, and SUVA standards.
- The switch contact is opened by a direct opening mechanism (NC contacts only) when the protective cover is opened. Direct opening mechanism that is EN-approved is indicated by  on the switch.
- Auxiliary release key ensures easy maintenance and unlocks the door in the case of a power failure.
- Tough aluminum die-cast body incorporating a switch box with degree of protection satisfying IP67, UL, and CSA TYPE6P, 13.
- Equipped with a horizontal and vertical conduit opening.
- Models incorporating easy-to-see indicators for monitoring and those using an adjustable Operation Key for a double door are available.
- The mounting direction of the head can be changed to allow the Operation Key to be inserted from four directions.
- Metric conduit types available



Model Number Structure

Model Number Legend

Switch

D4BL - -

1 2 3 4 5

1. Conduit Size (2-conduit)

- 1: PG13.5
- 2: G1/2
- 3: 1/2-14NPT
- 4: M20

2. Built-in Switch (with Safety Switch and Lock Monitor Switch Contacts)

- C: 1NC/1NO (slow-action) + 1NC (slow-action)
- D: 2NC (slow-action) + 1NC (slow-action)

3. Head Mounting Direction

- R: Four mounting directions possible (right-side mounting at shipping)

4. Door Lock and Release

(Auxiliary Release Key is Incorporated by All Models)

- A: Mechanical lock/24-VDC solenoid release
- B: Mechanical lock/110-VAC solenoid release
- G: 24-VDC Solenoid lock/Mechanical release

5. Indicator

- Blank: Without indicator
- A: 10 to 115 VAC or VDC driving (with orange and green LED indicator unit)

Operation Key (Order Separately)

D4BL - K

1

1. Operation Key Type

- 1: Horizontal mounting
- 2: Vertical mounting
- 3: Adjustable mounting (Horizontal)



Ordering Information

List of Models

Switches

Lock method	Conduit size	Voltage for solenoid	Without indicator 1NC/1NO+ 1NC (Slow-action)	With LED indicator 1NC/1NO+ 1NC (Slow-action)	Without indicator 2NC+ 1NC (Slow-action)	With LED indicator 2NC+ 1NC (Slow-action)
Mechanical lock	PG13.5	24 VDC	D4BL-1CRA	D4BL-1CRA-A	D4BL-1DRA	D4BL-1DRA-A
		110 VAC	D4BL-1CRB	D4BL-1CRB-A	D4BL-1DRB	D4BL-1DRB-A
	G1/2	24 VDC	D4BL-2CRA	D4BL-2CRA-A	D4BL-2DRA	D4BL-2DRA-A
		110 VAC	D4BL-2CRB	D4BL-2CRB-A	D4BL-2DRB	D4BL-2DRB-A
	M20	24 VDC	D4BL-4CRA	D4BL-4CRA-A	D4BL-4DRA	D4BL-4DRA-A
		110 VAC	D4BL-4CRB	D4BL-4CRB-A		
Solenoid lock	Pg 13.5	24 VDC	D4BL-1CRG	D4BL-1CRG-A	D4BL-1DRG	D4BL-1DRG-A
	G1/2	24 VDC	D4BL-2CRG	D4BL-2CRG-A	D4BL-2DRG	D4BL-2DRG-A
	M20	24 VDC		D4BL-4CRG-A		

Operation Keys (Order Separately)

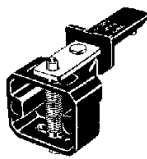
Mounting type	Model
Horizontal mounting 	D4BL-K1
Vertical mounting 	D4BL-K2
Adjustable mounting (Horizontal) 	D4BL-K3

Specifications

Approved Standards

Agency	Standard	File No.
TÜV Rheinland	EN60947-5-1	R9451050  (Direct opening: approved)
BIA	GS-ET-19	Mechanical lock: 9402293 Solenoid lock: 1998 20462-01
SUVA	SUVA	E6186/2.d
UL	UL508	E76675
CSA	CSA C22.2, No.14	LR45746

Standards and EC Directives

Conforms to the following EC Directives:
 Machinery Directive
 Low Voltage Directive
 EN1088

Approved Standard Ratings

TÜV (EN60947-5-1)

Item	Standard model	Indicator model
Utilization category	AC-15	AC-15
Rated operating current (Ie)	3 A	6 A
Rated operating voltage (Ue)	250 V	115 V

Use a 10-A fuse type gI or gG that conforms to IEC269 as a short-circuit protection device.

UL/CSA (UL508, CSA C22.2 No. 14)

A300

Rated voltage	Carry current	Current		Volt-amperes	
		Make	Break	Make	Break
120 VAC	10 A	60 A	6 A	7,200 VA	720 VA
240 VAC		30 A	3 A		

Note: The UL/CSA approved rating for products with indicators (-A) is 6 A/115 VAC.

Characteristics

Degree of protection	IP67 (See note 2.)
Durability (See note 3.)	Mechanical:1,000,000 operations min. Electrical:500,000 operations min. (10-A resistive load at 250 VAC)
Operating speed	0.05 to 0.5 m/s
Operating frequency	30 operations/min max.
Rated frequency	50/60 Hz
Operating characteristics	Direct opening force:19.61 N min. (EN60947-5-1) Direct opening travel:20 mm min. (EN60947-5-1) All stroke:23 mm min.
Holding force	700 N min. (GS-ET-19)
Insulation resistance	100 MΩ min. (at 500 VDC)
Rated insulation voltage (U _i)	300 V (EN60947-5-1)
Conventional enclosed thermal current (I _{the})	10 A (EN60947-5-1)
Dielectric strength (U _{imp})	Impulse dielectric strength (U _{imp}) 4 kV (EN60947-5-1) between terminals of different polarity, between each terminal and ground, and between each terminal and non-current-carrying metal part; 2.5 kV between solenoid and ground (EN60947-5-1)
Conditional short-circuit current	100 V (EN60947-5-1)
Pollution degree (operating environment)	3 (EN60947-5-1)
Protection against electric shock	Class I (with ground terminal)
Switching overvoltage	1,500 V max. (EN60947-5-1)
Contact resistance	50 mΩ max. (initial value)
Vibration resistance	Malfunction: 10 to 55 Hz, 0.35-mm single amplitude
Shock resistance	Destruction:1,000 m/s ² min. (IEC68-2-27) Malfunction:300 m/s ² min. (IEC68-2-27)
Ambient temperature	Operating:-10°C to 55°C (with no icing)
Ambient humidity	Operating:95% max.
Weight	Approx. 800 g

Note: 1. The above values are initial values.

2. Although the switch box is protected from dust, oil or water penetration, do not use the D4BL in places where dust, oil, water, or chemicals may penetrate through the key hole on the head, otherwise Switch damage or malfunctioning may occur.
3. The durability is for an ambient temperature of 5°C to 35°C and an ambient humidity of 40% to 70%.

Solenoid Coil Characteristics

Item	24-VDC mechanical lock models	110-VAC mechanical lock models	24-VAC solenoid lock models
Rated operating voltage	24 VDC $+10\%/_{-15\%}$ (100% ED)	110 VAC $\pm 10\%$ (50/60 Hz)	24 VDC $+10\%/_{-15\%}$ (100% ED)
Current consumption	Approx. 300 mA	Approx. 98 mA	Approx. 300 mA
Insulation	Class F (130°C or less)		

Indicator Characteristics

Item	LED
Rated voltage	10 to 115 VAC/VDC
Current leakage	Approx. 1 mA
Color (LED)	Orange, green

Contact Form (Diagrams Show State with Key Inserted and Lock Engaged)

Model	Contact	Diagram	Remarks
D4BL-□C□□□□	1NC/ 1NO+1NC		<p>Only NC contacts 11-12 and 31-32 have an approved direct opening mechanism. </p> <p>The terminals 11-12 and 23-24 can be used as unlike poles.</p>
D4BL-□D□□□□	2NC+1NC		<p>NC contacts 11-12, 21-22, and 31-32 have an approved direct opening mechanism. </p> <p>The terminals 11-12 and 21-22 can be used as unlike poles.</p>

Note: The EN-approved direct opening mechanism is indicated by on the switch.

D4BL

Connections

Indicator Unit

Dimensions

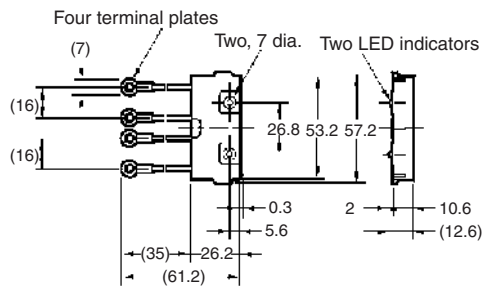

Internal Circuit

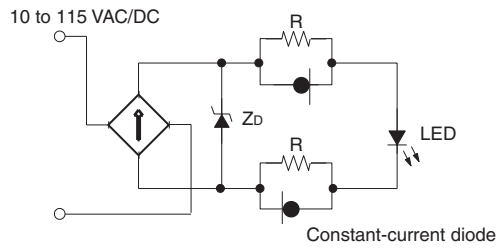

Circuit Connection Example

- Do not connect the indicators to the safety contact terminals (11-12-31-32) or the safety circuit side.
- When using indicators, connect them to the auxiliary circuit side (monitor circuit) or the solenoid input terminals as shown below.
- The indicators can be used to confirm the open/closed status of the door, the ON/OFF status of the power supply, and the ON/OFF status of the solenoid.

**1. Orange: Lights when the solenoid turns ON.
Green: Lights when the door opens.**

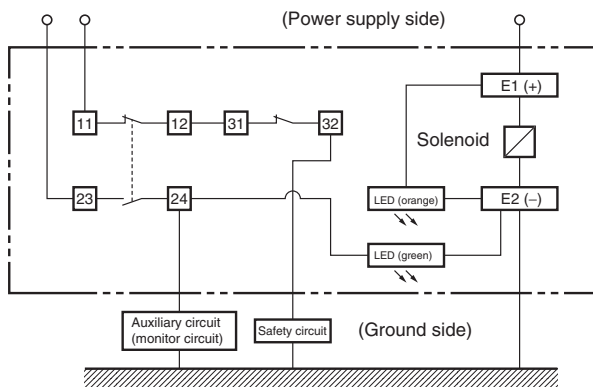

- Do not connect the indicators in parallel with the direct opening contact. If the indicators are broken, a short-circuit current may flow, causing equipment to malfunction.
- The 24-VDC solenoid terminals have polarity. Confirm the polarity before wiring.
- Be sure to use a special pushbutton switch to stop and start machinery and release locks.

**2. Orange: Lights when the solenoid turns ON.
Green: Lights when power turns ON.**

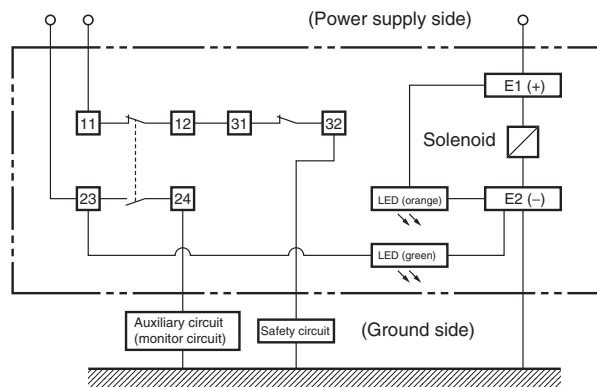

**3. Orange: Lights when the solenoid turns ON.
Green: Lights when door closes.**

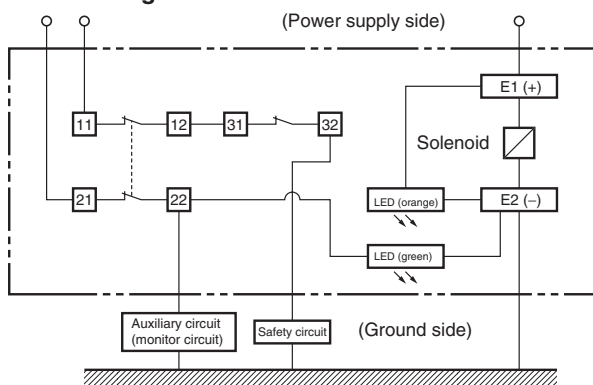

**4. Orange: Lights when the solenoid turns ON.
Green: Lights when power turns ON.**

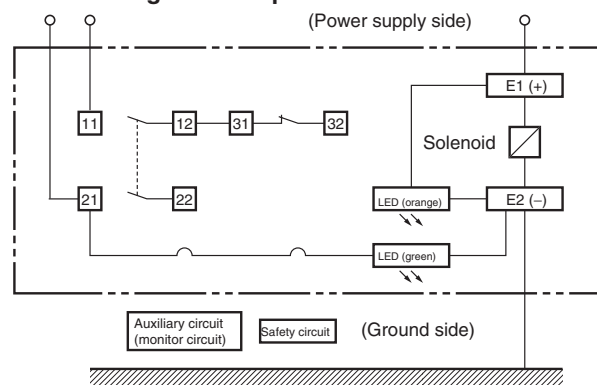

Nomenclature

D4BL-□C□□-□

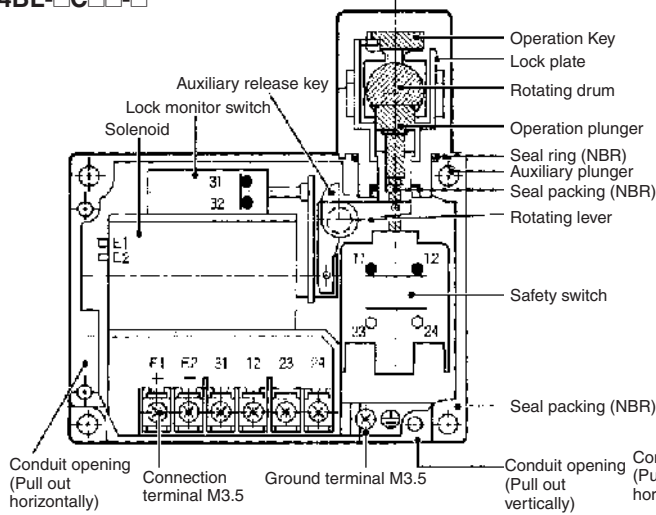

D4BL-□D□□-□

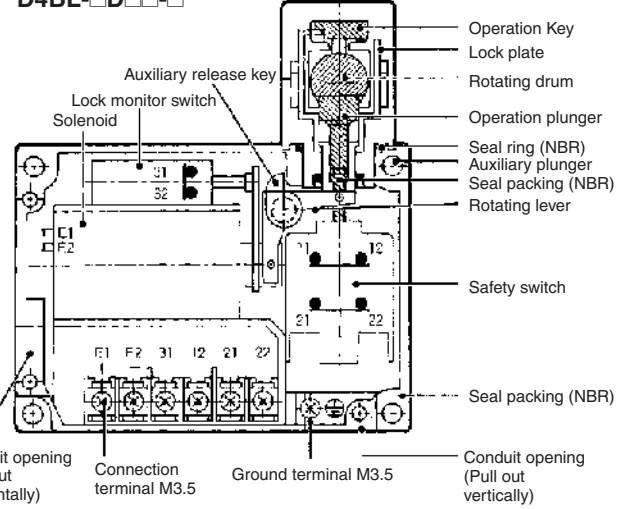

Dimensions

- Note:** 1. All units are in millimeters unless otherwise indicated.
 2. Unless otherwise specified, a tolerance of ± 0.4 mm applies to all dimensions.

Switches

D4BL-□□□□-□

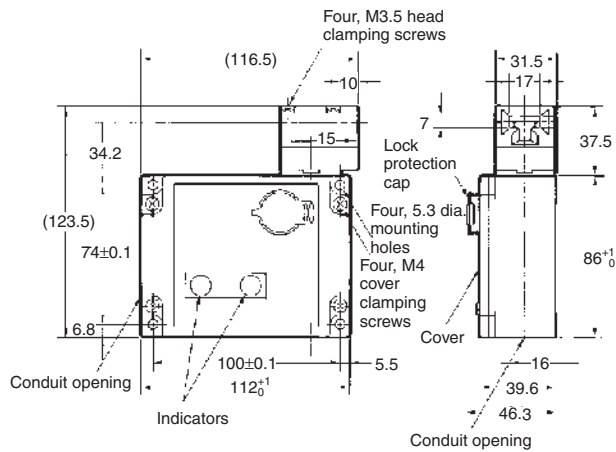
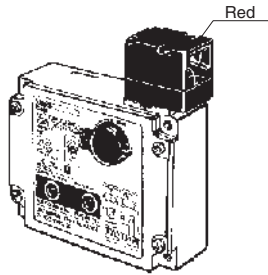

Operating Characteristics	D4BL-□□□□
Key insertion force	19.61 N max.
Key extraction force	19.61 N max.
Movement before being locked	15 mm max.

Operation Keys

Horizontal Mounting
D4BL-K1

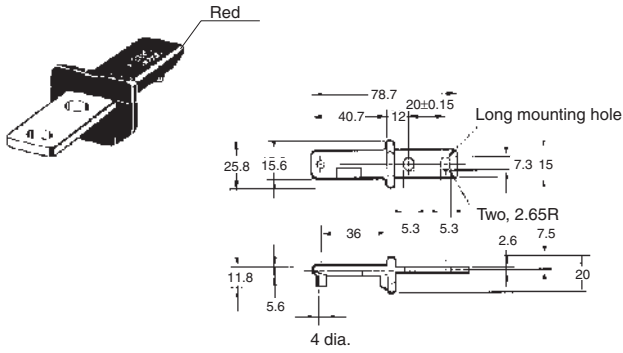

Vertical Mounting
D4BL-K2

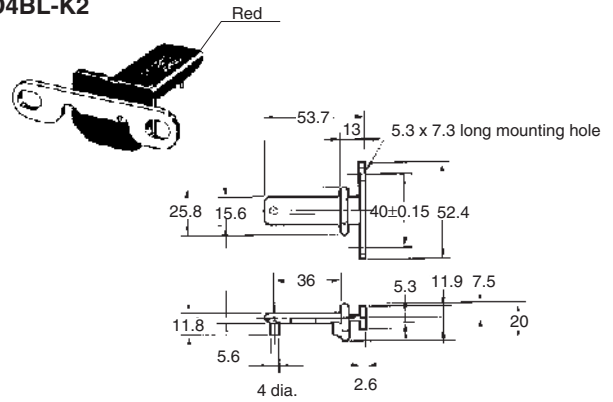

Adjustable Mounting (Horizontal)
D4BL-K3

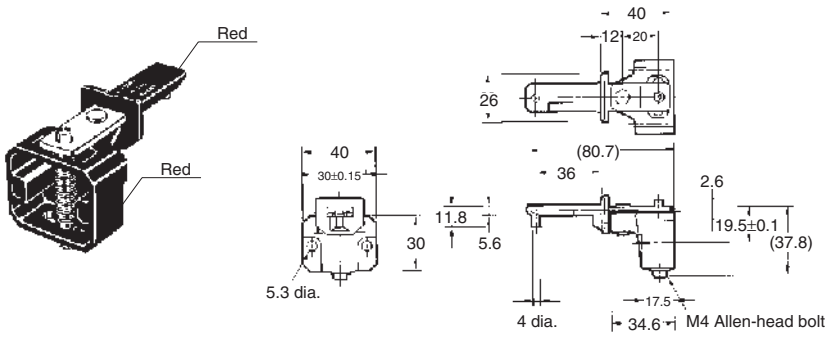

With Operation Key Inserted

Horizontal Mounting

D4BL + D4BL-K1

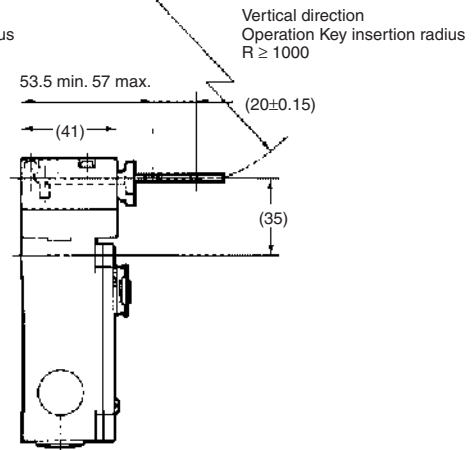
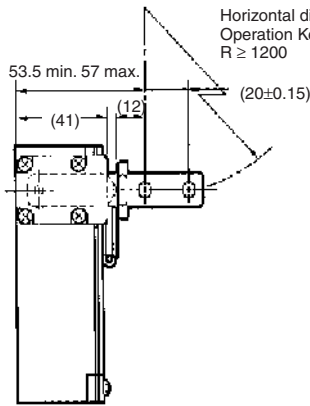
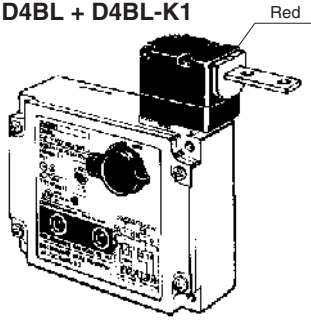

Vertical Mounting

D4BL + D4BL-K2

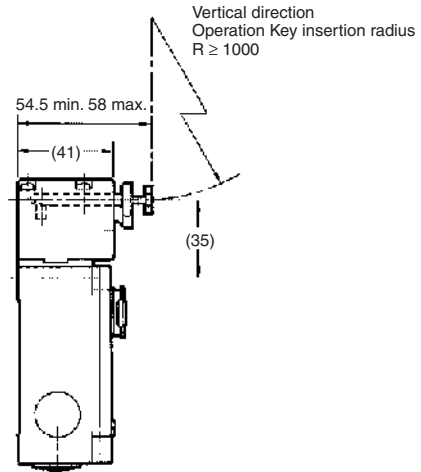
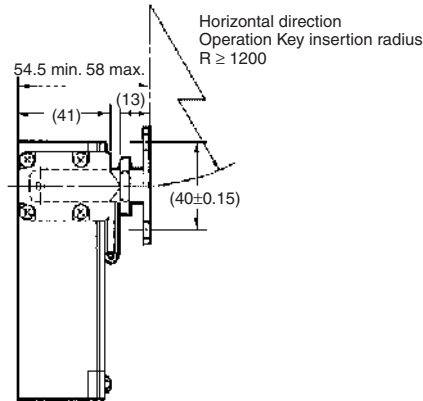
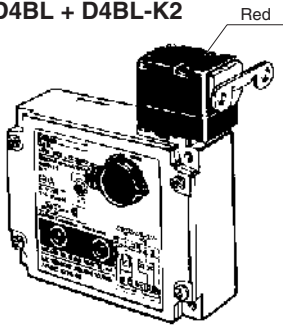

Adjustable Mounting (Horizontal)

D4BL + D4BL-K3

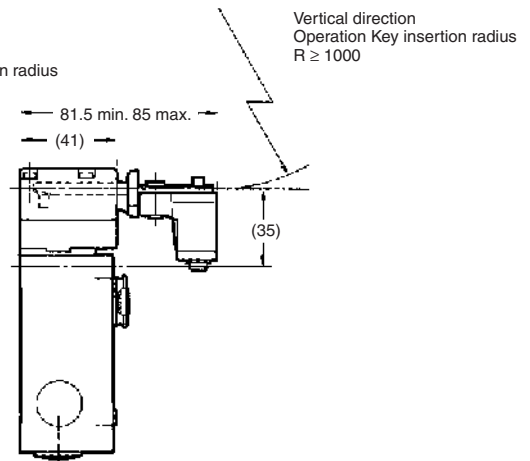
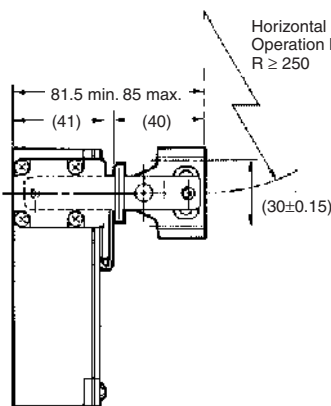
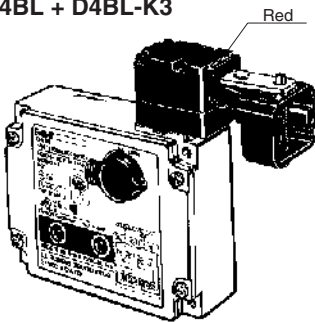

- Note:** 1. Unless otherwise specified, a tolerance of ± 0.4 mm applies to all dimensions.
2. In the above diagrams, the Operation Key is inserted from the front.

Precautions

Caution

Do not insert the Operation Key to the Switch with the door open. Before using the machine, be sure to remove the shock-absorbing damper, which is provided before shipping. Otherwise the machine may start operating and injury may be caused.

Mount the Operation Key at a location where it will not come in contact with users when the door is opened or closed.

When operating the D4BL as a part of a safety circuit or an emergency stop circuit to prevent injury, operate the NC contacts that have a direct opening mechanism in direct opening mode. For safety purposes, tighten the switch body and Operation Key with one-way screws or equivalents or install a switch protection cover and warning label for safety purposes to prevent easy removal of the D4BL.

Connect the fuse to the D4BL in series to prevent it from short-circuit damage. The value of the breaking current of the fuse must be calculated by multiplying rated current by 150% to 200%.

When using the D4BL with EN ratings, use 10-A fuse Type gI or gG that complies with IEC60269.

In order to prevent the D4BL from burning due to overvoltage, insert a protection fuse into the solenoid circuit.

If the D4BL is imposed with force exceeding the lock strength, the D4BL may break and the equipment may continue to operate.

Auxiliary Release Key

The auxiliary release key is used to unlock the D4BL in case of emergency or in case the power supply to the D4BL fails.

Use an appropriate tool to set the auxiliary release key to UNLOCK so that the lock will be released and the door can be opened.

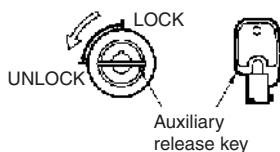

The auxiliary release key applied to the door of a machine room ensures the safety of people adjusting the equipment in the machine room. If the auxiliary release key is set to UNLOCK, the door will not be locked when the door is closed and no power will be supplied to the equipment.

To lock the door, set the auxiliary release key to LOCK.

Do not use the auxiliary release key to start or stop machines.

To prevent the auxiliary release key from being handled carelessly by unauthorized people, seal the auxiliary release key with sealing wax and the provided seal cap to ensure IP67.

Make sure that the auxiliary release key is kept with the person in charge.

Before attaching the cover to the D4BL, make sure that the auxiliary release key position is set to LOCK.

Stopper

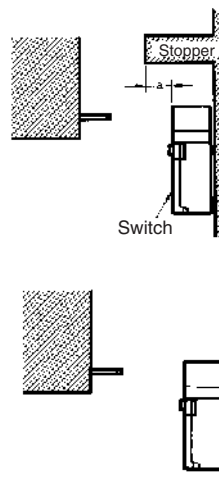

Do not use the Switch as a stopper. When mounting the Switch, be sure to locate a stopper as shown in the following illustration to prevent the top of the Operation Key from hitting the switch head.

Correct Use

Operating Environment

Due to the wear and tear of the sealing of the D4BL, water and some types of oil and chemical sprayed onto the D4BL may cause contact or insulation failures, current leakages, or fires.

Do not use the D4BL in the following locations.

- Locations subject to severe temperature changes
- Locations subject to high temperatures or condensation
- Locations subject to severe vibration
- Locations where the product may come in contact with metal dust, oil, or chemicals

Operation Key

The D4BL is provided with a shock-absorbing damper to protect the D4BL from damage that may result from dropping the D4BL during transportation. Be sure to remove the damper after mounting the D4BL.

The mounting tolerance of the Operation Key is ± 0.3 mm vertically or horizontally. Be sure to mount the D4BL correctly without leaning, otherwise the D4BL may soon break or wear out.

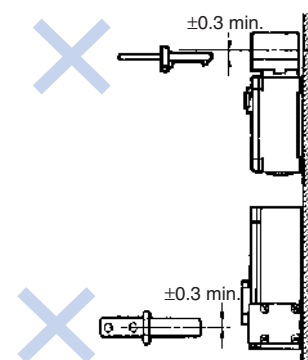

Do not drop the D4BL with the Operation Key inserted, otherwise the Operation Key may deform or break.

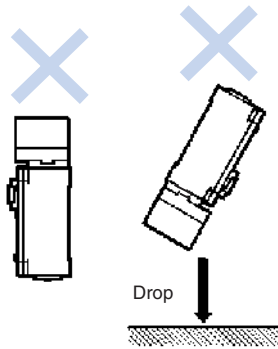

The head is constructed so that it cannot be operated with tools such as screwdrivers. Always use OMRON's Operation Key to operate the head in order to ensure the safety of the machine and protect the D4BL from damage.

The Operation Key provided for the D4BL is not compatible with that of the D4BS.

Mount the Operation Key and secure it with one-way screws or equivalents to prevent easy removal of the D4BL.

Securing the Door

If the Operation Key on the closed door is pulled outside the set zone by a force caused by vibration, the door's weight, or the door cushion rubber, the D4BL may be damaged. Secure the door with hooks so that it will remain within the set zone.

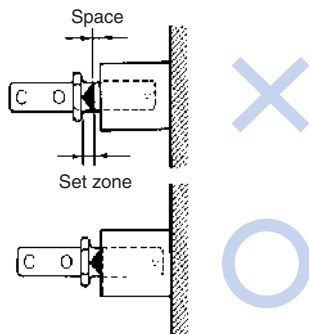

Tightening Torque

Be sure to tighten each screw of the D4BL properly, otherwise the D4BL may malfunction.

	Type	Torque
1	M3.5 terminal screw (including terminal screw)	0.59 to 0.78 N·m
2	Cover mounting screw	1.18 to 1.37 N·m
3	Head mounting screw	0.78 to 0.98 N·m
4	M5 body mounting screw	4.90 to 5.88 N·m
5	Operation Key mounting screw	2.35 to 2.75 N·m
6	Connector	1.77 to 2.16 N·m
7	Cap screw	1.27 to 1.67 N·m

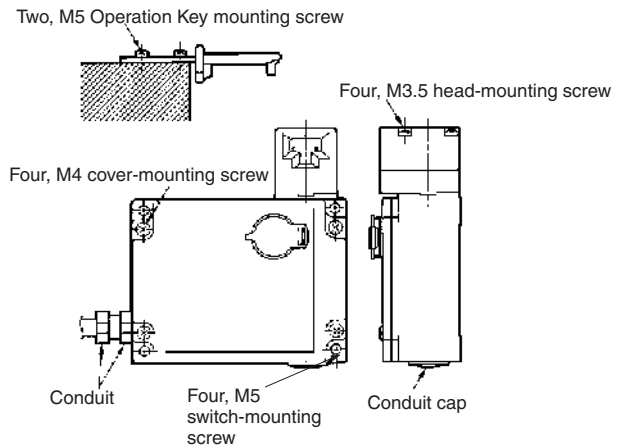

Switch and Operation Key Mounting

Mount the D4BL and Operation Key with four M5 screws with washers and tighten each screw to the specified torque.

Mounting Dimensions

Switch Mounting Dimensions

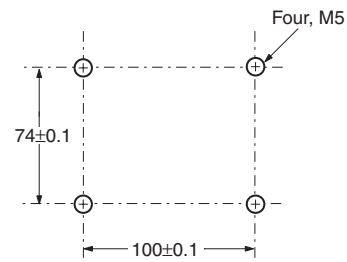

Operation Key Mounting Holes

- Horizontal Mounting D4BL-K1

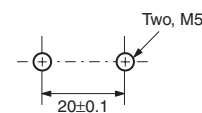

- Vertical Mounting D4BL-K2

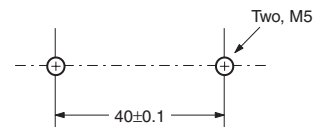

- Adjustable Mounting (Horizontal) D4BL-K3

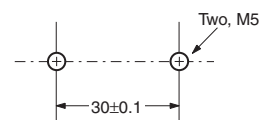

Head Directions

The head can be mounted in four directions. To remove the head, turn the head by 45° as shown in figures A and B below.

To change the direction of the head, make sure that the protruding part of the rotating lever engages with the groove of the plunger. Then turn the head clockwise or counterclockwise to the desired direction. At that time, make sure that the groove of the plunger is located under the rotating lever. If the direction of the head is not set when the plunger is rotated by 45°, the groove of the plunger presses the rotating lever. The head, plunger, or the built-in switch may be damaged as a result.

Head Direction Changes

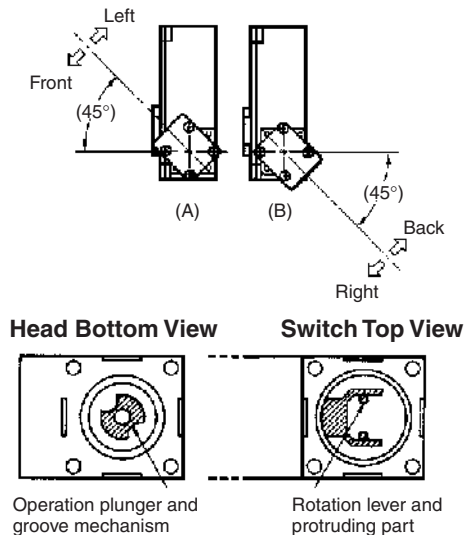

Normal Positions of Rotating Lever and Plunger

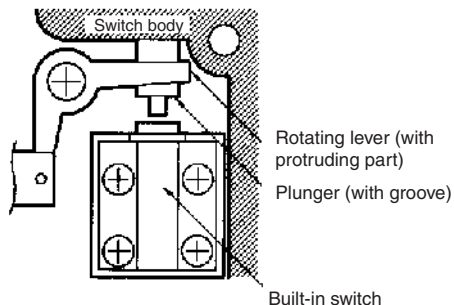

Be sure to check the mechanical lock and solenoid release functions when mounting the D4BL.

If the head direction is changed, recheck the tightening torque of each of screw. Make sure that no foreign materials will penetrate through the key hole on the head.

Mounting the Cover

When tightening the cover, first check the specified torque, and then tighten each screw to the that torque. Also, make sure that no foreign matter has entered the switch.

When mounting the cover, make sure that the cover and switch box are properly aligned.

Processing and Connecting Cable/Conduit

The following procedures are recommended for mounting and wiring the indicator unit securely.

In order to ensure IP67, use OMRON's SC-□M and Nippon Flex's ABS-08Pg13.5 and ABS-12 Pg13.5 Connectors.

Recommended cable: UL2464-type cable that is 20 to 18 AWG (0.5 to 1.0 mm²) in size and has seven conductors

If the 1/2-14NPT is used, cover the cable and conduit end with sealing tape in order to ensure IP67. Tighten the connector to a torque of 1.77 to 2.16 N·m.

Connect the indicator unit after connecting the seven-conductor cable.

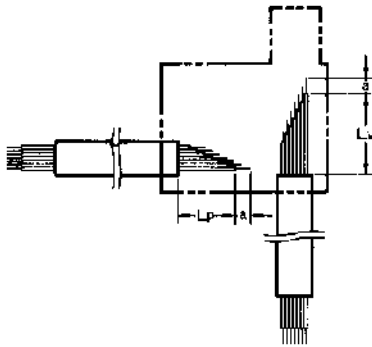

Terminal no.	Lp (mm)	Lv (mm)	a (mm)
E ₁	30±2	80±2	8±1
E ₂	35±2	75±2	
31	45±2	60±2	
12	55±2	50±2	
23 (21)	65±2	45±2	
24 (22)	70±2	35±2	
⊕	90±2	50±2	

Properly attach and securely tighten the provided conduit cap to the unused conduit opening when wiring the D4BL.

Cable Connection Example

1. Connect the wires to the terminals in the order shown below for wiring efficiency.

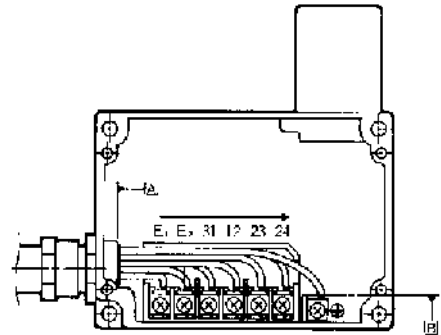

Tighten each wired terminal clockwise to a torque of 0.59 to 0.78 N·m.

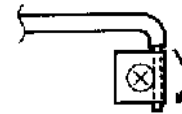

Twist the wire two or three times and make sure that no bare wire exists outside the terminal when tightening the terminal.

2. The insulation sheath of the seven-conductor cable must come into contact with the wall of the conduit mouth, side A or side B.

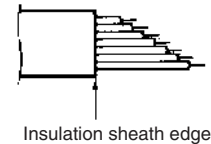

Maintenance and Repairs

Contact your OMRON representative for any repair or maintenance work on the D4BL. The D4BL must not be maintained or repaired by any unauthorized party.

Others

Do not touch the solenoid because the solenoid radiates heat while power is being supplied.

Компания «Океан Электроники» предлагает заключение долгосрочных отношений при поставках импортных электронных компонентов на взаимовыгодных условиях!

Наши преимущества:

- Поставка оригинальных импортных электронных компонентов напрямую с производств Америки, Европы и Азии, а так же с крупнейших складов мира;
- Широкая линейка поставок активных и пассивных импортных электронных компонентов (более 30 млн. наименований);
- Поставка сложных, дефицитных, либо снятых с производства позиций;
- Оперативные сроки поставки под заказ (от 5 рабочих дней);
- Экспресс доставка в любую точку России;
- Помощь Конструкторского Отдела и консультации квалифицированных инженеров;
- Техническая поддержка проекта, помощь в подборе аналогов, поставка прототипов;
- Поставка электронных компонентов под контролем ВП;
- Система менеджмента качества сертифицирована по Международному стандарту ISO 9001;
- При необходимости вся продукция военного и аэрокосмического назначения проходит испытания и сертификацию в лаборатории (по согласованию с заказчиком);
- Поставка специализированных компонентов военного и аэрокосмического уровня качества (Xilinx, Altera, Analog Devices, Intersil, Interpoint, Microsemi, Actel, Aeroflex, Peregrine, VPT, Syfer, Eurofarad, Texas Instruments, MS Kennedy, Miteq, Cobham, E2V, MA-COM, Hittite, Mini-Circuits, General Dynamics и др.);

Компания «Океан Электроники» является официальным дистрибьютором и эксклюзивным представителем в России одного из крупнейших производителей разъемов военного и аэрокосмического назначения «**JONHON**», а так же официальным дистрибьютором и эксклюзивным представителем в России производителя высокотехнологичных и надежных решений для передачи СВЧ сигналов «**FORSTAR**».



JONHON

«**JONHON**» (основан в 1970 г.)

Разъемы специального, военного и аэрокосмического назначения:

(Применяются в военной, авиационной, аэрокосмической, морской, железнодорожной, горно- и нефтедобывающей отраслях промышленности)

«**FORSTAR**» (основан в 1998 г.)

ВЧ соединители, коаксиальные кабели, кабельные сборки и микроволновые компоненты:

(Применяются в телекоммуникациях гражданского и специального назначения, в средствах связи, РЛС, а так же военной, авиационной и аэрокосмической отраслях промышленности).



Телефон: 8 (812) 309-75-97 (многоканальный)

Факс: 8 (812) 320-03-32

Электронная почта: ocean@oceanchips.ru

Web: <http://oceanchips.ru/>

Адрес: 198099, г. Санкт-Петербург, ул. Калинина, д. 2, корп. 4, лит. А