



MCP1640
Synchronous Boost Converter
Evaluation Board
User's Guide

Note the following details of the code protection feature on Microchip devices:

- Microchip products meet the specification contained in their particular Microchip Data Sheet.
- Microchip believes that its family of products is one of the most secure families of its kind on the market today, when used in the intended manner and under normal conditions.
- There are dishonest and possibly illegal methods used to breach the code protection feature. All of these methods, to our knowledge, require using the Microchip products in a manner outside the operating specifications contained in Microchip's Data Sheets. Most likely, the person doing so is engaged in theft of intellectual property.
- Microchip is willing to work with the customer who is concerned about the integrity of their code.
- Neither Microchip nor any other semiconductor manufacturer can guarantee the security of their code. Code protection does not mean that we are guaranteeing the product as "unbreakable."

Code protection is constantly evolving. We at Microchip are committed to continuously improving the code protection features of our products. Attempts to break Microchip's code protection feature may be a violation of the Digital Millennium Copyright Act. If such acts allow unauthorized access to your software or other copyrighted work, you may have a right to sue for relief under that Act.

Information contained in this publication regarding device applications and the like is provided only for your convenience and may be superseded by updates. It is your responsibility to ensure that your application meets with your specifications. MICROCHIP MAKES NO REPRESENTATIONS OR WARRANTIES OF ANY KIND WHETHER EXPRESS OR IMPLIED, WRITTEN OR ORAL, STATUTORY OR OTHERWISE, RELATED TO THE INFORMATION, INCLUDING BUT NOT LIMITED TO ITS CONDITION, QUALITY, PERFORMANCE, MERCHANTABILITY OR FITNESS FOR PURPOSE. Microchip disclaims all liability arising from this information and its use. Use of Microchip devices in life support and/or safety applications is entirely at the buyer's risk, and the buyer agrees to defend, indemnify and hold harmless Microchip from any and all damages, claims, suits, or expenses resulting from such use. No licenses are conveyed, implicitly or otherwise, under any Microchip intellectual property rights.

Trademarks

The Microchip name and logo, the Microchip logo, dsPIC, KEELOQ, KEELOQ logo, MPLAB, PIC, PICmicro, PICSTART, PIC³² logo, rPIC and UNI/O are registered trademarks of Microchip Technology Incorporated in the U.S.A. and other countries.

FilterLab, Hampshire, HI-TECH C, Linear Active Thermistor, MXDEV, MXLAB, SEEVAL and The Embedded Control Solutions Company are registered trademarks of Microchip Technology Incorporated in the U.S.A.

Analog-for-the-Digital Age, Application Maestro, CodeGuard, dsPICDEM, dsPICDEM.net, dsPICworks, dsSPEAK, ECAN, ECONOMONITOR, FanSense, HI-TIDE, In-Circuit Serial Programming, ICSP, Mindi, MiWi, MPASM, MPLAB Certified logo, MPLIB, MPLINK, mTouch, Octopus, Omniscient Code Generation, PICC, PICC-18, PICDEM, PICDEM.net, PICKit, PICtail, REAL ICE, rLAB, Select Mode, Total Endurance, TSHARC, UniWinDriver, WiperLock and ZENA are trademarks of Microchip Technology Incorporated in the U.S.A. and other countries.

SQTP is a service mark of Microchip Technology Incorporated in the U.S.A.

All other trademarks mentioned herein are property of their respective companies.

© 2010, Microchip Technology Incorporated, Printed in the U.S.A., All Rights Reserved.

 Printed on recycled paper.

ISBN: 978-1-60932-023-2

**QUALITY MANAGEMENT SYSTEM
CERTIFIED BY DNV
== ISO/TS 16949:2002 ==**

Microchip received ISO/TS-16949:2002 certification for its worldwide headquarters, design and wafer fabrication facilities in Chandler and Tempe, Arizona; Gresham, Oregon and design centers in California and India. The Company's quality system processes and procedures are for its PIC[®] MCUs and dsPIC[®] DSCs, KEELOQ[®] code hopping devices, Serial EEPROMs, microperipherals, nonvolatile memory and analog products. In addition, Microchip's quality system for the design and manufacture of development systems is ISO 9001:2000 certified.



MCP1640 SYNCHRONOUS BOOST CONVERTER EVALUATION BOARD USER'S GUIDE

Table of Contents

Preface	5
Introduction.....	5
Document Layout	5
Conventions Used in this Guide	6
Recommended Reading.....	7
The Microchip Web Site	7
Customer Support	7
Document Revision History	8
Chapter 1. Product Overview	
1.1 Introduction	9
1.2 What is the MCP1640 Synchronous Boost Converter Evaluation Board?	9
1.3 What the MCP1640 Synchronous Boost Converter Evaluation Board Includes	10
Chapter 2. Installation and Operation	
2.1 Introduction	11
2.2 Features	12
2.3 Getting Started	12
Appendix A. Schematic and Layouts	
A.1 Introduction	15
A.2 Board – Schematic	16
A.3 Board – Top Silk and Pads	17
A.4 Board – Top Copper Layer	18
A.5 Board – Bottom Copper Layer	19
Appendix B. Bill of Materials (BOM)	
Worldwide Sales and Service	22

NOTES:



MCP1640 SYNCHRONOUS BOOST CONVERTER EVALUATION BOARD USER'S GUIDE

Preface

NOTICE TO CUSTOMERS

All documentation becomes dated, and this manual is no exception. Microchip tools and documentation are constantly evolving to meet customer needs, so some actual dialogs and/or tool descriptions may differ from those in this document. Please refer to our web site (www.microchip.com) to obtain the latest documentation available.

Documents are identified with a “DS” number. This number is located on the bottom of each page, in front of the page number. The numbering convention for the DS number is “DSXXXXA”, where “XXXX” is the document number and “A” is the revision level of the document.

For the most up-to-date information on development tools, see the MPLAB® IDE on-line help. Select the Help menu, and then Topics to open a list of available on-line help files.

INTRODUCTION

This chapter contains general information that will be useful to know before using the MCP1640 Synchronous Boost Converter Evaluation Board. Items discussed in this chapter include:

- Document Layout
- Conventions Used in this Guide
- Recommended Reading
- The Microchip Web Site
- Customer Support
- Document Revision History

DOCUMENT LAYOUT

This document describes how to use the MCP1640 Synchronous Boost Converter Evaluation Board as a development tool. The manual layout is as follows:

- **Chapter 1. “Product Overview”** – Important information about the MCP1640 Synchronous Boost Converter Evaluation Board.
- **Chapter 2. “Installation and Operation”** – Includes instructions on how to get started with this user’s guide and a description of the user’s guide.
- **Appendix A. “Schematic and Layouts”** – Shows the schematic and layout diagrams for the MCP1640 Synchronous Boost Converter Evaluation Board.
- **Appendix B. “Bill of Materials (BOM)”** – Lists the parts used to build the MCP1640 Synchronous Boost Converter Evaluation Board.

CONVENTIONS USED IN THIS GUIDE

This manual uses the following documentation conventions:

DOCUMENTATION CONVENTIONS

Description	Represents	Examples
Arial font:		
Italic characters	Referenced books	<i>MPLAB[®] IDE User's Guide</i>
	Emphasized text	...is the <i>only</i> compiler...
Initial caps	A window	the Output window
	A dialog	the Settings dialog
	A menu selection	select Enable Programmer
Quotes	A field name in a window or dialog	"Save project before build"
Underlined, italic text with right angle bracket	A menu path	<u><i>File>Save</i></u>
Bold characters	A dialog button	Click OK
	A tab	Click the Power tab
N'Rnnnn	A number in verilog format, where N is the total number of digits, R is the radix and n is a digit.	4'b0010, 2'hF1
Text in angle brackets < >	A key on the keyboard	Press <Enter>, <F1>
Courier New font:		
Plain Courier New	Sample source code	#define START
	Filenames	autoexec.bat
	File paths	c:\mcc18\h
	Keywords	_asm, _endasm, static
	Command-line options	-Opa+, -Opa-
	Bit values	0, 1
	Constants	0xFF, 'A'
Italic Courier New	A variable argument	<i>file.o</i> , where <i>file</i> can be any valid filename
Square brackets []	Optional arguments	mcc18 [options] <i>file</i> [options]
Curly brackets and pipe character: { }	Choice of mutually exclusive arguments; an OR selection	errorlevel {0 1}
Ellipses...	Replaces repeated text	var_name [, var_name...]
	Represents code supplied by user	void main (void) { ... }

RECOMMENDED READING

This user's guide describes how to use MCP1640 Synchronous Boost Converter Evaluation Board. Other useful documents are listed below. The following Microchip documents are available and recommended as supplemental reference resources.

- **MCP1640/B/C/D Data Sheet (DS22234)**

This data sheet provides detailed information regarding the MCP1640 device.

- **AN1311, Single Cell Input Boost Converter Design (DS01311)**

This application note details how to use the MCP1640 device in specific applications.

THE MICROCHIP WEB SITE

Microchip provides online support via our web site at www.microchip.com. This web site is used as a means to make files and information easily available to customers. Accessible by using your favorite Internet browser, the web site contains the following information:

- **Product Support** – Data sheets and errata, application notes and sample programs, design resources, user's guides and hardware support documents, latest software releases and archived software
- **General Technical Support** – Frequently Asked Questions (FAQs), technical support requests, online discussion groups, Microchip consultant program member listing
- **Business of Microchip** – Product selector and ordering guides, latest Microchip press releases, listing of seminars and events, listings of Microchip sales offices, distributors and factory representatives

CUSTOMER SUPPORT

Users of Microchip products can receive assistance through several channels:

- Distributor or Representative
- Local Sales Office
- Field Application Engineer (FAE)
- Technical Support

Customers should contact their distributor, representative or field application engineer (FAE) for support. Local sales offices are also available to help customers. A listing of sales offices and locations is included in the back of this document.

Technical support is available through the web site at: <http://support.microchip.com>

DOCUMENT REVISION HISTORY

Revision A (February 2010)

- Initial Release of this Document.

Chapter 1. Product Overview

1.1 INTRODUCTION

The MCP1640 is a compact, high-efficiency, fixed frequency, step-up DC-DC converter. It provides an easy-to-use power supply solution, with a minimum number of external components for applications powered by one-cell, two-cell, or three-cell alkaline, NiCd, NiMH, one-cell Li-Ion or Li-Polymer batteries.

The MCP1640 automatically selects the best operating mode for efficiency, Pulse Width Modulation (PWM) or Pulse Frequency (PFM); it has a low quiescent current (20 μ A), a wide input voltage range (0.35 to 5.5V) and low start-up voltage (0.65V).

The MCP1640 is available in SOT-23-6 and 2x3mm-8 DFN packages.

This chapter provides an overview of the MCP1640 Boost Controller Evaluation Board and covers the following topics:

- What is the MCP1640 Synchronous Boost Converter Evaluation Board?
- Contents of the MCP1640 Synchronous Boost Converter Evaluation Board

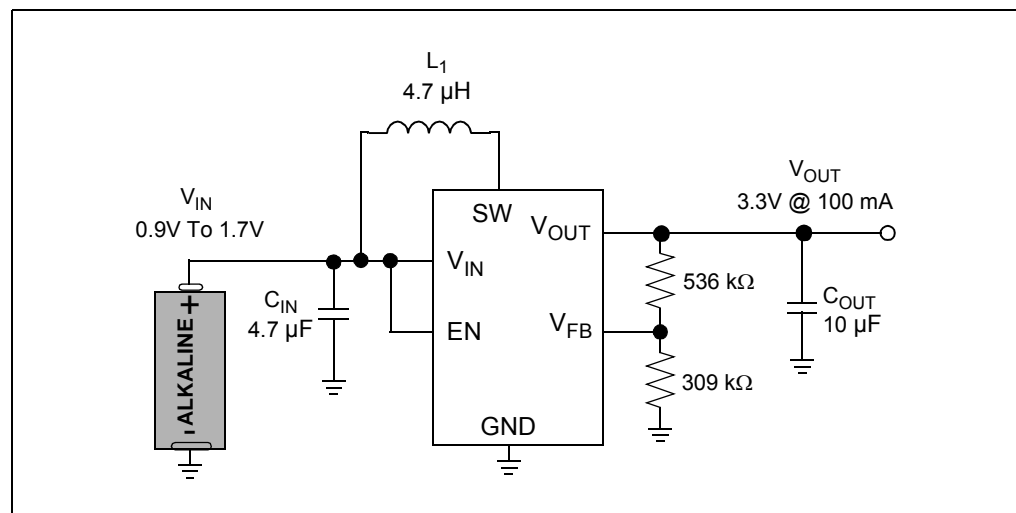

FIGURE 1-1: Typical MCP1640 Boost Converter Single Cell Battery Input.

1.2 WHAT IS THE MCP1640 SYNCHRONOUS BOOST CONVERTER EVALUATION BOARD?

The MCP1640 Synchronous Boost Converter Evaluation Board is used to evaluate and demonstrate Microchip Technology's MCP1640 products. This board demonstrates the MCP1640 in two boost-converter applications with multiple output voltages. It can be used to evaluate both package options (SOT-23-6 and 2x3-8 DFN). The MCP1640 Synchronous Boost Converter Evaluation Board was developed to help engineers reduce the product design cycle time.

Three common output voltages can be selected: 2.0V, 3.3V and 5.0V. The output voltage can be changed with a mini-dip switch that changes the external resistor divider.

An enable (EN Switch selection) is used to enable and disable the MCP1640. When enabled, the MCP1640 will regulate the output voltage; when disabled, the MCP1640 disconnects the path from input to output for “true-disconnect”.

Additional, MCP1640 options provide continuous switching and input to output bypass. For more information on these options, refer to the MCP1640/B/C/D datasheet.

1.3 CONTENTS OF THE MCP1640 SYNCHRONOUS BOOST CONVERTER EVALUATION BOARD

This MCP1640 Synchronous Boost Converter Evaluation Board kit includes:

- One MCP1640 Synchronous Boost Converter Evaluation Board unit, 102-00283
- Important Information "Read First"

Chapter 2. Installation and Operation

2.1 INTRODUCTION

The MCP1640 is a compact, high-efficiency, fixed frequency, synchronous step-up dc-dc converter. It provides an easy-to-use power supply solution for applications powered by one-cell, two-cell, or three-cell alkaline, NiCd, NiMH, one-cell Li-Ion or Li-Polymer batteries in addition to distributed 3.3V to 5.0V applications.

The MCP1640 is capable of regulating the output voltage over a wide 2.0V to 5.5V range and typically can deliver over 100 mA of load current at 3.3V output when supplied from a single 1.2V cell. The input voltage range is 0.35V to 5.5V with a low 0.65V start-up voltage. The regulated output voltage, V_{OUT} should be greater than or equal to the input voltage, V_{IN} . Additional device features are: automatic PWM / PFM transition to optimize efficiency, low device quiescent current (20 μ A in PFM mode and 1 μ A in stand-by mode), multiple and selectable, logic controlled shutdown states (true load disconnect or "bypass", output connected to input), low noise and discontinuous current anti-ringing control.

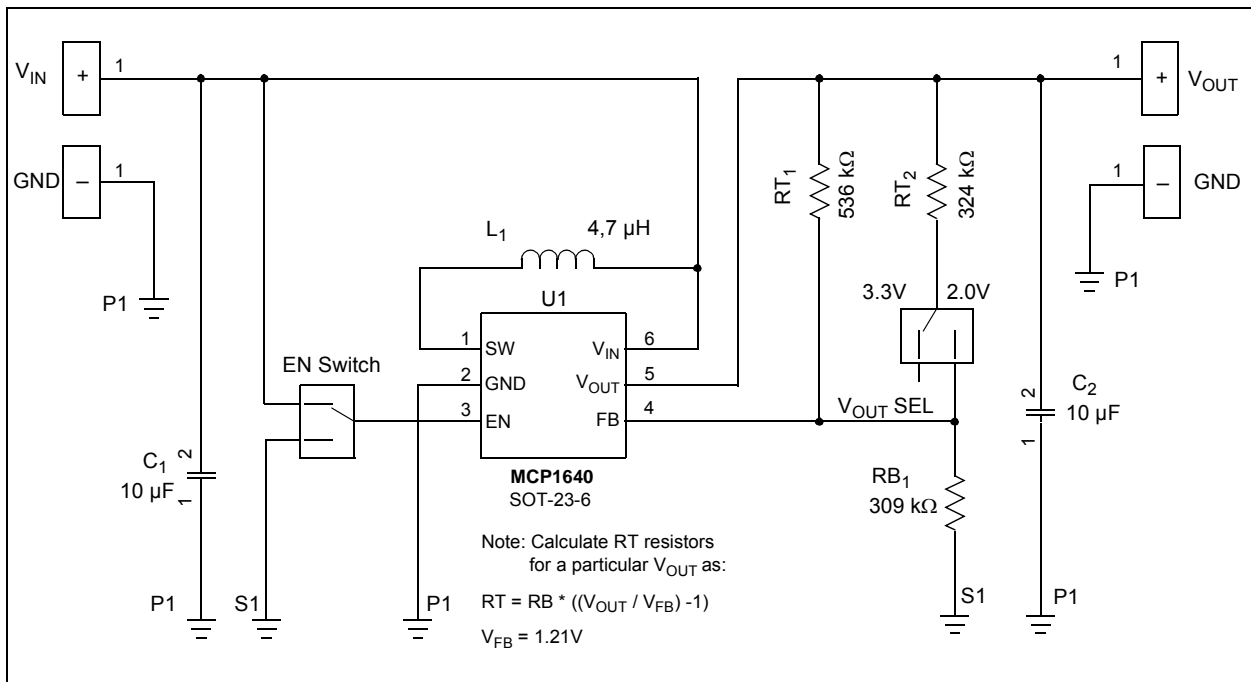

FIGURE 2-1: MCP1640 Synchronous Boost SOT-23-6 Application.

Two enable mode options are available: true disconnect and bypass. When disabled, the true disconnect option removes the normal boost topology path from input to output by opening the diode path using a P-Channel synchronous switch with a reversible body diode. The bypass option uses the synchronous boost converter P-Channel switch to connect the input to the output through the boost inductor while disabled providing voltage to the load, while consuming less than 1 μ A of current from V_{IN} .

The MCP1640 is available in SOT-23-6 and 2x3 mm DFN-8 lead packages.

The MCP1640 Evaluation Board offers both package types in two boost-converter applications for 2.0V, 3.3V and 5.0V output voltage options that can be selected using a mini dip switch. The enable input is controlled in both boost converter applications using a mini dip switch.

2.2 FEATURES

The MCP1640 Synchronous Boost Converter Evaluation Board has the following features:

- It can be powered by one-cell, two-cell, or three-cell alkaline, NiCd, NiMH, one-cell Li-Ion or Li-Polymer batteries
- Input voltage range, V_{IN} : 0.35V to 5.5V, with $V_{IN} \leq V_{OUT}$; 1 mA load after startup
- Fixed output voltage: 2.0V or 3.3V and 3.3V or 5.0V, selected using a mini dip switch on board
- Output current: typical 100 mA @ 3.3V Output, 1.2V Input or 300 mA @ 5.0V Output, 3.3V Input
- Start-up voltage: 0.65V at $V_{IN} = 1.2V$, $V_{OUT} = 3.3V$ and $I_{OUT} = 1mA$, resistive load
- Automatic PFM/PWM Operation
- PWM Switching Frequency = 500 kHz
- Enable state selectable using mini-dip switch on board
- Peak Input Current Limit
- Overtemperature (if the die temperature exceeds 150°C, 10°C hysteresis)

2.3 GETTING STARTED

The MCP1640 Synchronous Boost Converter Evaluation Board is fully assembled and tested to evaluate and demonstrate the MCP1640 products. This board requires the use of external lab supplies and load.

2.3.1 Power Input and Output Connection

2.3.1.1 POWERING THE MCP1640 SYNCHRONOUS BOOST CONVERTER EVALUATION BOARD

Soldered test points are available for input voltage connections. The maximum input voltage should not exceed 6.0V. The output voltage will not remain in regulation for input voltages that are greater than or equal to the output voltage.

The MCP1640 Synchronous Boost Converter Evaluation Board has two independent circuit applications, one using the MCP1640 SOT-23-6 package, while the other one uses the MCP1640 DFN-8 package. The SOT-23-6 package has two output voltage settings (2.0V and 3.3V) selectable by an on board mini-dip switch. The DFN-8 package has two output voltage settings (3.3V and 5.0V) also selectable by an on board mini-dip switch.

Soldered test points are available to connect a load. The MCP1640 switch peak current limit will provide a safe maximum current value. The maximum output current for the MCP1640 will vary with input and output voltages; refer to the MCP1640 datasheet for more information on the maximum output current. As an example, the MCP1640 can typically supply a 3.3V load with 100 mA with a 1.2V input.

Installation and Operation

2.3.1.2 BOARD POWER UP PROCEDURE:

1. Connect system load to V_{OUT} and GND terminals, maximum load varies with input and output voltage; see the MCP1640 datasheet for more information on the maximum load. Typically, the MCP1640 can supply a 3.3V output with 100 mA from a 1.2V input source. Connect the (+) side of the load to V_{OUT} and the negative (-) load to ground (GND).
2. Set the desired output voltage using the V_{OUT} SEL mini dip switch.
3. Set the enable to the desired state using the EN mini dip switch.
4. When EN is set ON or high, the MCP1640 is enabled and V_{OUT} can be measured on the V_{OUT} and GND terminals. When EN is low, the MCP1640 is disabled and V_{OUT} is floating and disconnected from the input.

Capacitors C_3 , C_4 , C_6 and C_7 are not populated. The component pads are provided for experimental use.

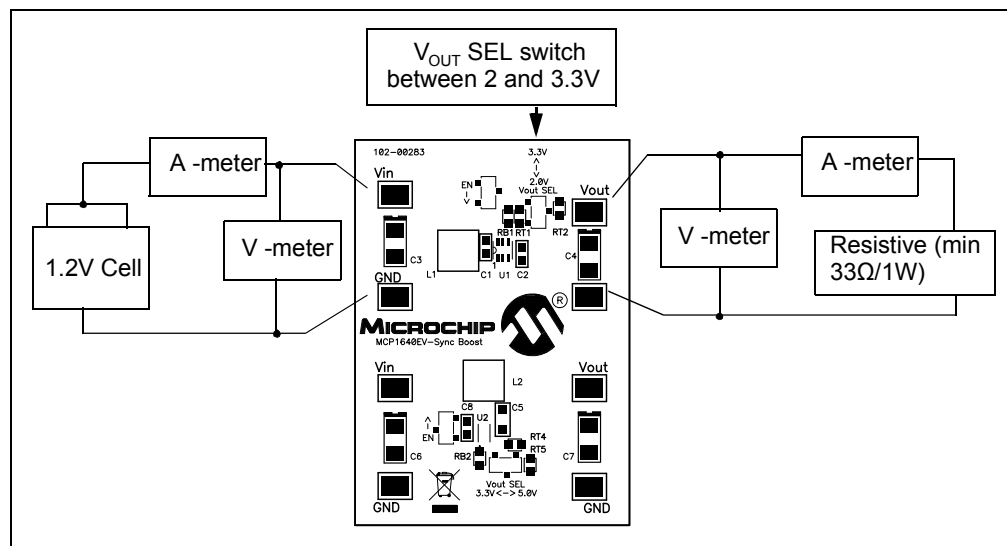

FIGURE 2-2: MCP1640 Evaluation Board Setup.

2.3.1.3 EN AND V_{OUT} SEL SWITCHES FUNCTION

TABLE 2-1: FUNCTION OF BOARD SWITCHES

State of Switches		V_{OUT} [V] for	
SW3 or SW4 EN Switch	SW1 or SW2 V_{OUT} SEL Switch	SOT-23-6 Converter	2x3 mm DFN Converter
ON	ON	2	3.3
ON	OFF	3.3	5
OFF	ON	0	0
OFF	OFF	0	0

Note that SW2 (V_{OUT} SEL) and SW4 (EN) are used for the SOT-23-6 circuit. Switches SW1 (V_{OUT} SEL) and SW3 (EN) are used for the 2x3 mm DFN-8 circuit.

2.3.1.4 ADJUSTABLE V_{OUT} SETTING

The resistor divider RT and RB are used to set the converter output voltage. By setting the V_{OUT} SEL switch in the open or OFF position, the output voltage can be calculated using the following equation:

$$RT_1 = RB_1 \times \left[\left(\frac{V_{OUT}}{V_{FB}} \right) - 1 \right]$$

OR

$$RT_4 = RB_2 \times \left[\left(\frac{V_{OUT}}{V_{FB}} \right) - 1 \right]$$

Where: $V_{FB} = 1.21V$

Note: The V_{OUT} SEL switch will not be used.



MCP1640 SYNCHRONOUS BOOST CONVERTER EVALUATION BOARD USER'S GUIDE

Appendix A. Schematic and Layouts

A.1 INTRODUCTION

This appendix contains the following schematics and layouts for the MCP1640 Synchronous Boost Converter Evaluation Board:

- Board – Schematic
- Board – Top Silk and Pads
- Board – Top Copper Layer
- Board – Bottom Copper Layer

A.2 BOARD – SCHEMATIC

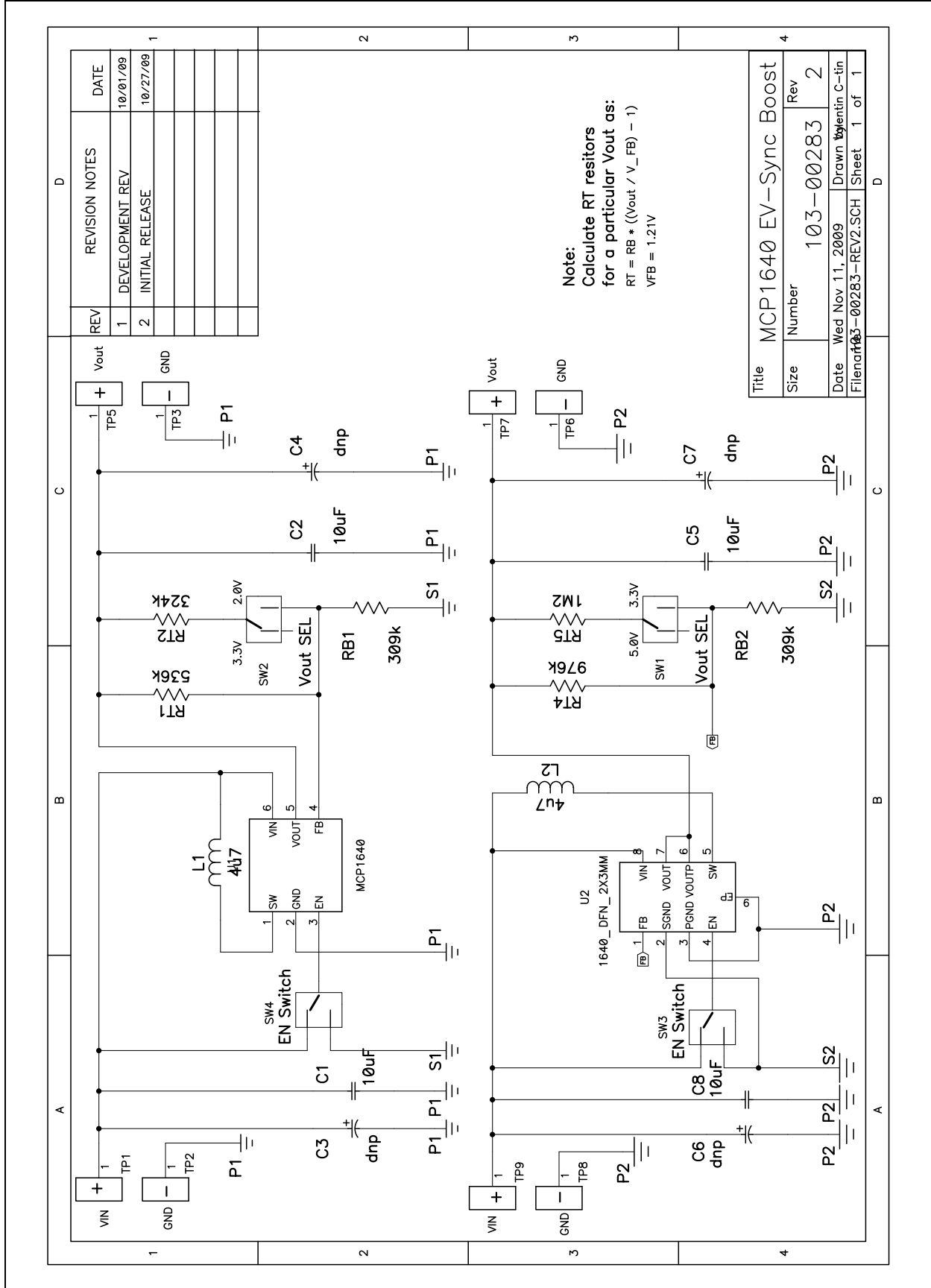

A.3 BOARD – TOP SILK AND PADS

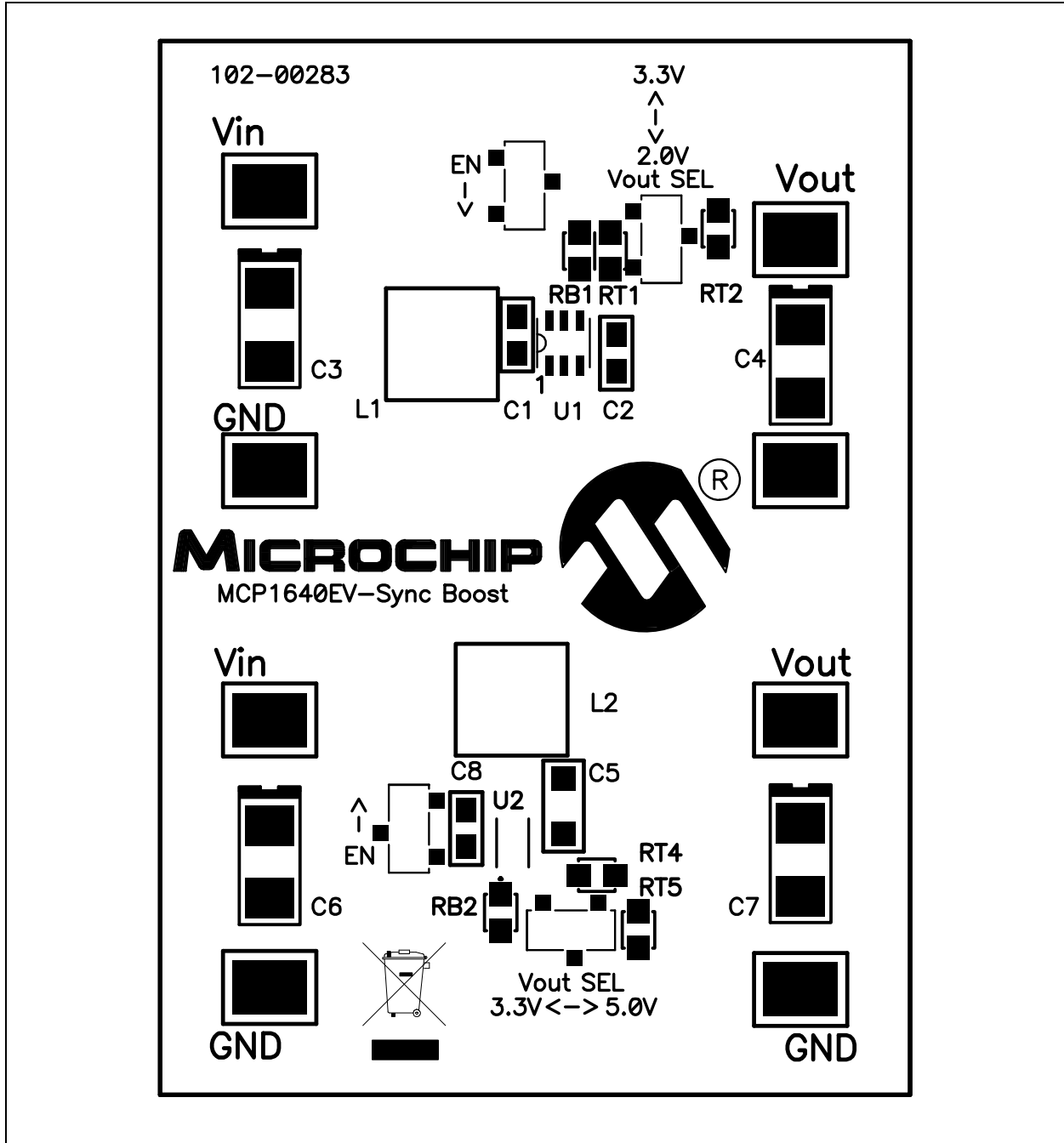

A.4 BOARD – TOP COPPER LAYER

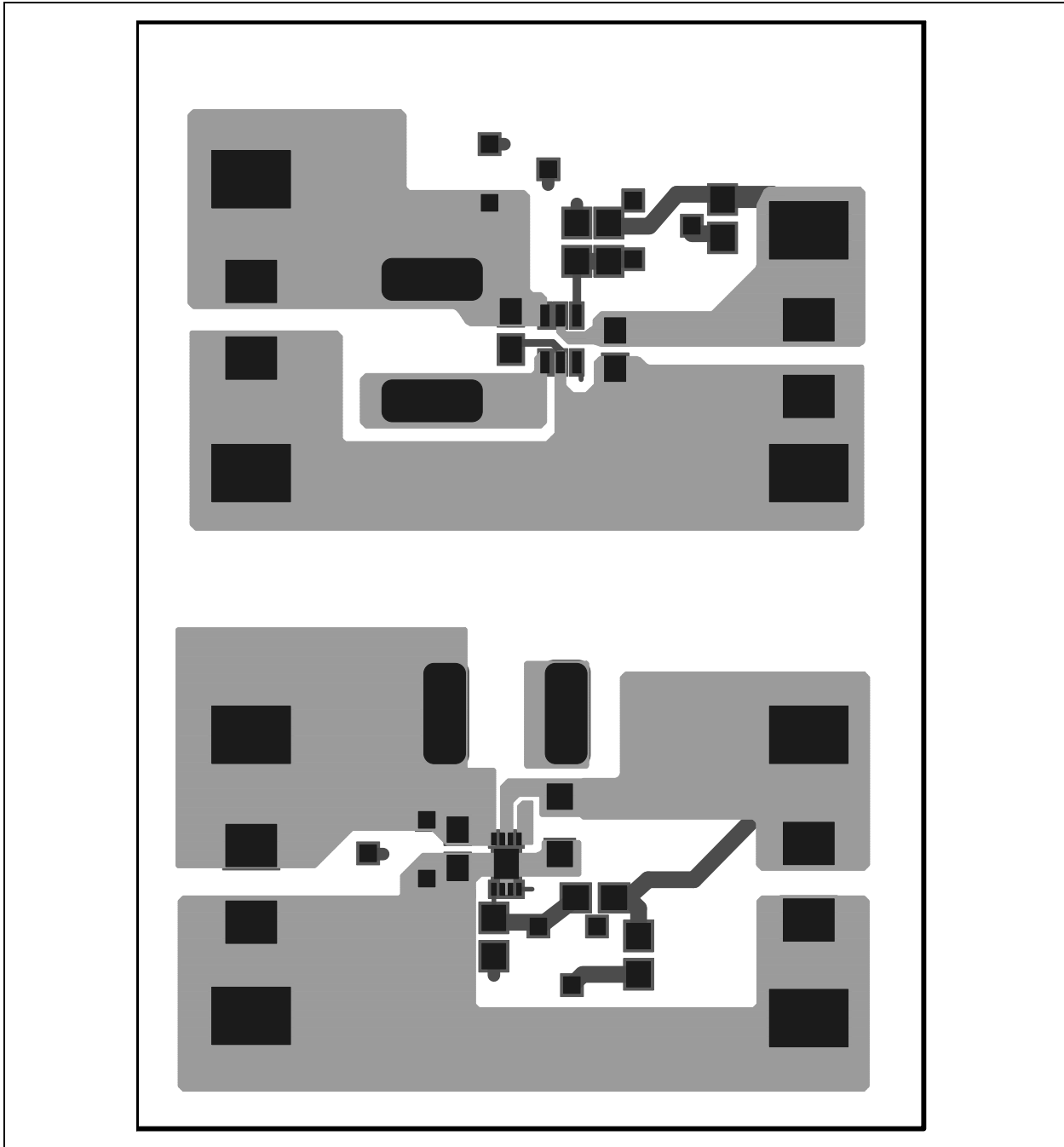

A.5 BOARD – BOTTOM COPPER LAYER

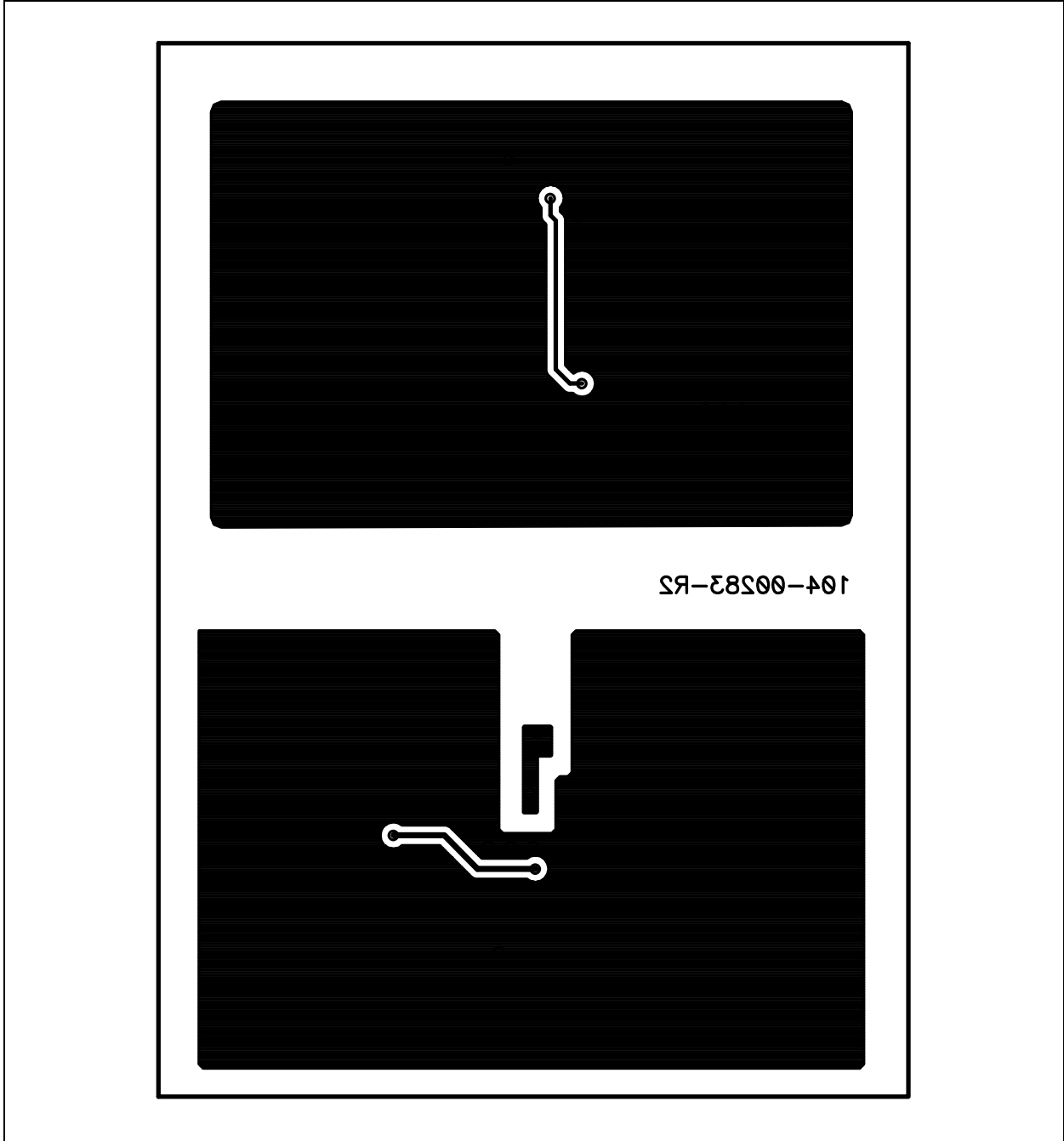

NOTES:



MCP1640 SYNCHRONOUS BOOST CONVERTER EVALUATION BOARD USER'S GUIDE

Appendix B. Bill of Materials (BOM)

TABLE B-1: BILL OF MATERIALS (BOM)

Qty	Reference	Description	Manufacturer	Part Number
4	Bump	BUMPON HEMISPHERE .44X.20 WHITE	3M	SJ-5003 (WHITE)
3	C1, C2, C8	CAP CER 10UF 10V X7R 0805	Murata Electronics North America	GRM21BR71A106KE51L
0	C3, C4, C6, C7	CAP TANT LOW ESR SMD 6032-EIA / C case	—	—
1	C5	CAP CER 10UF 10V X7R 1206	Murata Electronics North America	GRM31CR71A106KA01L
2	L1, L2	INDUCTOR POWER 4.7UH 2.0A SMD	EPCOS Inc	B82462G4472M
1	PCB	RoHS Compliant Bare PCB, MCP1640 Sync Boost Converter Evaluation Board	Microchip Technology Inc.	104-00283
2	RB1, RB2	RES 309K OHM 1/8W 1% 0805 SMD	Rohm Semiconductor	MCR10EZPF3093
1	RT1	RES 536K OHM 1/8W 1% 0805 SMD	Yageo	RC0805FR-07536KL
1	RT2	RES 324K OHM 1/8W 1% 0805 SMD	Rohm Semiconductor	MCR10EZPF3243
1	RT4	RES 976K OHM 1/8W 1% 0805 SMD	Rohm Semiconductor	MCR10EZHF9763
1	RT5	RES 1.20M OHM 1/8W 1% 0805 SMD	Rohm Semiconductor	MCR10EZHF1204
4	SW1, SW2, SW3, SW4	SWITCH SLIDE SPDT SMD GULL	Copal Electronics Inc	CJS-1200TB
8	TP1, TP2, TP3, TP5, TP6, TP7, TP8, TP9	PC Test Point Compact SMT	Keystone Electronics	5016
1	U1	MCP1640 Synchronous Boost Converter - SOT23-6	Microchip Technology Inc.	MCP1640
1	U2	MCP1640 Synchronous Boost Converter – DFN2x3mm	Microchip Technology Inc.	MCP1640

Note 1: The components listed in this Bill of Materials are representative of the PCB assembly. The released BOM used in manufacturing uses all RoHS-compliant components.



WORLDWIDE SALES AND SERVICE

AMERICAS

Corporate Office
2355 West Chandler Blvd.
Chandler, AZ 85224-6199
Tel: 480-792-7200
Fax: 480-792-7277
Technical Support:
<http://support.microchip.com>
Web Address:
www.microchip.com

Atlanta
Duluth, GA
Tel: 678-957-9614
Fax: 678-957-1455

Boston
Westborough, MA
Tel: 774-760-0087
Fax: 774-760-0088

Chicago
Itasca, IL
Tel: 630-285-0071
Fax: 630-285-0075

Cleveland
Independence, OH
Tel: 216-447-0464
Fax: 216-447-0643

Dallas
Addison, TX
Tel: 972-818-7423
Fax: 972-818-2924

Detroit
Farmington Hills, MI
Tel: 248-538-2250
Fax: 248-538-2260

Kokomo
Kokomo, IN
Tel: 765-864-8360
Fax: 765-864-8387

Los Angeles
Mission Viejo, CA
Tel: 949-462-9523
Fax: 949-462-9608

Santa Clara
Santa Clara, CA
Tel: 408-961-6444
Fax: 408-961-6445

Toronto
Mississauga, Ontario,
Canada
Tel: 905-673-0699
Fax: 905-673-6509

ASIA/PACIFIC

Asia Pacific Office
Suites 3707-14, 37th Floor
Tower 6, The Gateway
Harbour City, Kowloon
Hong Kong
Tel: 852-2401-1200
Fax: 852-2401-3431

Australia - Sydney
Tel: 61-2-9868-6733
Fax: 61-2-9868-6755

China - Beijing
Tel: 86-10-8528-2100
Fax: 86-10-8528-2104

China - Chengdu
Tel: 86-28-8665-5511
Fax: 86-28-8665-7889

China - Chongqing
Tel: 86-23-8980-9588
Fax: 86-23-8980-9500

China - Hong Kong SAR
Tel: 852-2401-1200
Fax: 852-2401-3431

China - Nanjing
Tel: 86-25-8473-2460
Fax: 86-25-8473-2470

China - Qingdao
Tel: 86-532-8502-7355
Fax: 86-532-8502-7205

China - Shanghai
Tel: 86-21-5407-5533
Fax: 86-21-5407-5066

China - Shenyang
Tel: 86-24-2334-2829
Fax: 86-24-2334-2393

China - Shenzhen
Tel: 86-755-8203-2660
Fax: 86-755-8203-1760

China - Wuhan
Tel: 86-27-5980-5300
Fax: 86-27-5980-5118

China - Xian
Tel: 86-29-8833-7252
Fax: 86-29-8833-7256

China - Xiamen
Tel: 86-592-2388138
Fax: 86-592-2388130

China - Zhuhai
Tel: 86-756-3210040
Fax: 86-756-3210049

ASIA/PACIFIC

India - Bangalore
Tel: 91-80-3090-4444
Fax: 91-80-3090-4123

India - New Delhi
Tel: 91-11-4160-8631
Fax: 91-11-4160-8632

India - Pune
Tel: 91-20-2566-1512
Fax: 91-20-2566-1513

Japan - Yokohama
Tel: 81-45-471- 6166
Fax: 81-45-471-6122

Korea - Daegu
Tel: 82-53-744-4301
Fax: 82-53-744-4302

Korea - Seoul
Tel: 82-2-554-7200
Fax: 82-2-558-5932 or
82-2-558-5934

Malaysia - Kuala Lumpur
Tel: 60-3-6201-9857
Fax: 60-3-6201-9859

Malaysia - Penang
Tel: 60-4-227-8870
Fax: 60-4-227-4068

Philippines - Manila
Tel: 63-2-634-9065
Fax: 63-2-634-9069

Singapore
Tel: 65-6334-8870
Fax: 65-6334-8850

Taiwan - Hsin Chu
Tel: 886-3-6578-300
Fax: 886-3-6578-370

Taiwan - Kaohsiung
Tel: 886-7-536-4818
Fax: 886-7-536-4803

Taiwan - Taipei
Tel: 886-2-2500-6610
Fax: 886-2-2508-0102

Thailand - Bangkok
Tel: 66-2-694-1351
Fax: 66-2-694-1350

EUROPE

Austria - Wels
Tel: 43-7242-2244-39
Fax: 43-7242-2244-393

Denmark - Copenhagen
Tel: 45-4450-2828
Fax: 45-4485-2829

France - Paris
Tel: 33-1-69-53-63-20
Fax: 33-1-69-30-90-79

Germany - Munich
Tel: 49-89-627-144-0
Fax: 49-89-627-144-44

Italy - Milan
Tel: 39-0331-742611
Fax: 39-0331-466781

Netherlands - Drunen
Tel: 31-416-690399
Fax: 31-416-690340

Spain - Madrid
Tel: 34-91-708-08-90
Fax: 34-91-708-08-91

UK - Wokingham
Tel: 44-118-921-5869
Fax: 44-118-921-5820

Компания «Океан Электроники» предлагает заключение долгосрочных отношений при поставках импортных электронных компонентов на взаимовыгодных условиях!

Наши преимущества:

- Поставка оригинальных импортных электронных компонентов напрямую с производств Америки, Европы и Азии, а так же с крупнейших складов мира;
- Широкая линейка поставок активных и пассивных импортных электронных компонентов (более 30 млн. наименований);
- Поставка сложных, дефицитных, либо снятых с производства позиций;
- Оперативные сроки поставки под заказ (от 5 рабочих дней);
- Экспресс доставка в любую точку России;
- Помощь Конструкторского Отдела и консультации квалифицированных инженеров;
- Техническая поддержка проекта, помощь в подборе аналогов, поставка прототипов;
- Поставка электронных компонентов под контролем ВП;
- Система менеджмента качества сертифицирована по Международному стандарту ISO 9001;
- При необходимости вся продукция военного и аэрокосмического назначения проходит испытания и сертификацию в лаборатории (по согласованию с заказчиком);
- Поставка специализированных компонентов военного и аэрокосмического уровня качества (Xilinx, Altera, Analog Devices, Intersil, Interpoint, Microsemi, Actel, Aeroflex, Peregrine, VPT, Syfer, Eurofarad, Texas Instruments, MS Kennedy, Miteq, Cobham, E2V, MA-COM, Hittite, Mini-Circuits, General Dynamics и др.);

Компания «Океан Электроники» является официальным дистрибьютором и эксклюзивным представителем в России одного из крупнейших производителей разъемов военного и аэрокосмического назначения «**JONHON**», а так же официальным дистрибьютором и эксклюзивным представителем в России производителя высокотехнологичных и надежных решений для передачи СВЧ сигналов «**FORSTAR**».



JONHON

«**JONHON**» (основан в 1970 г.)

Разъемы специального, военного и аэрокосмического назначения:

(Применяются в военной, авиационной, аэрокосмической, морской, железнодорожной, горно- и нефтедобывающей отраслях промышленности)

«**FORSTAR**» (основан в 1998 г.)

ВЧ соединители, коаксиальные кабели,
кабельные сборки и микроволновые компоненты:

(Применяются в телекоммуникациях гражданского и специального назначения, в средствах связи, РЛС, а так же военной, авиационной и аэрокосмической отраслях промышленности).



Телефон: 8 (812) 309-75-97 (многоканальный)

Факс: 8 (812) 320-03-32

Электронная почта: ocean@oceanchips.ru

Web: <http://oceanchips.ru/>

Адрес: 198099, г. Санкт-Петербург, ул. Калинина, д. 2, корп. 4, лит. А