



MIC23153 Evaluation Board

4MHz PWM 2A Buck Regulator with
HyperLight Load™ and Power Good

General Description

This board enables the evaluation of the MIC23153, a fully integrated 2A, 4MHz switching regulator featuring HyperLight Load™ mode, Power Good output indicator, and programmable soft-start. The MIC23153 is highly efficient throughout the entire output current range, drawing just 23µA of quiescent current in operation. The tiny 2.5mm x 2.5mm Thin MLF® package, in combination with the 4MHz switching frequency, enables a compact sub-1mm height solution with only four external components. The MIC23153 provides accurate output voltage regulation under the most demanding conditions and responds extremely quickly to a load transient with exceptionally small output voltage ripple.

Requirements

This board needs a single 10W bench power source adjustable from 2.7V to 5.5V. The loads can either be active (electronic load) or passive (resistor) with the capability to dissipate 7W. It is ideal to have an oscilloscope available to view the circuit waveforms, but not essential. For the simplest tests, two Voltage meters are required to measure input and output voltage. For efficiency measurements, two Voltage meters and two Ammeters are required to prevent errors due to measurement inaccuracies.

Precautions

There is no reverse input protection on this board. Be cautious when connecting the input source to ensure correct polarity is observed.

Getting Started

1. **Connect an external supply to the V_{IN} (J4) terminal and GND (J3).** With the output of the power supply disabled, set its voltage to the desired input test voltage ($2.7V \leq V_{IN} \leq 5.5V$). An ammeter may be placed between the input supply and the V_{IN} (J4) terminal. Be sure to monitor the supply voltage at the V_{IN} (J4) terminal, as the ammeter and/or power lead resistance can reduce the voltage supplied to the device.
2. **Connect a load to the V_{OUT} (J1) and ground (J2) terminals.** The load can be either active passive (resistive) or active (electronic load). An ammeter may be placed between the load and the output terminal. Ensure the output voltage is monitored at the V_{OUT} (J1) terminal.
3. **Enable the MIC23153.** The MIC23153 evaluation board has a pull-up resistor to V_{IN}. By default, the output voltage will be enabled when the input supply of >2.7V is applied. To disable the device, apply a voltage below 0.5V to the EN (J6) terminal.
4. **Power Good.** A Power good test point (J5) is provided to monitor the Power Good function. The Power Good output will go high (V_{out}) approximately 70µs after the output voltage reaches 92% of its nominal voltage.

Ordering Information

Part Number	Description
MIC23153-GYMT	1.8V Fixed Output Evaluation Board
MIC23153YMT	Adjustable Output Evaluation Board

HyperLight Load is a trademark of Micrel, Inc.
MLF and MicroLeadFrame are registered trademark Amkor Technology Inc.

Micrel Inc. • 2180 Fortune Drive • San Jose, CA 95131 • USA • tel +1 (408) 944-0800 • fax + 1 (408) 474-1000 • <http://www.micrel.com>

Evaluation Board

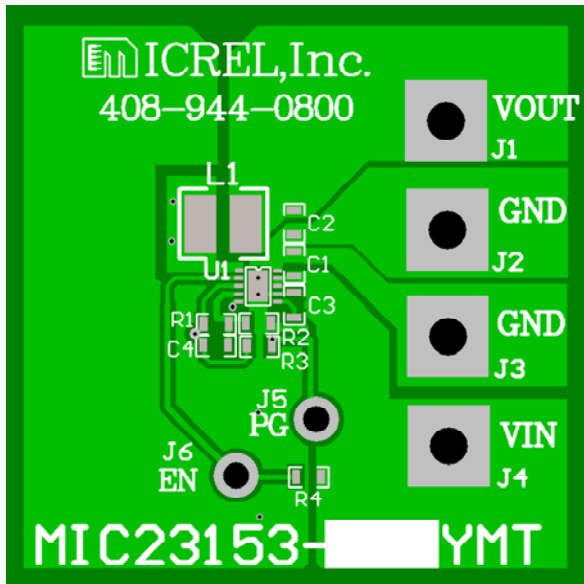

Other Features

Soft-Start Capacitor (C3)

The MIC23153 has a nominal 270kOhm resistor charging the capacitor on the SS pin. This enables the output to follow a controlled soft start characteristic. Setting C3 to 100pF sets the startup time to the minimum. The start-up time can be determined by:

$$T_{SS} = 270 \times 10^3 \times \ln(10) \times C_{SS}$$

The action of the soft-start capacitor is to control the rise time of the internal reference voltage between 0% and 100% of its nominal steady state value.

Feedback Resistors (R1, R2) for Adjustable Output

The output voltage is set nominally to 1.8V. This output can be changed by adjusting the upper resistor, R1, in the feedback potential divider. Therefore:

$$R1 = R2 \times V_{REF} / (V_O - V_{REF})$$

Where $V_{REF} = 0.62V$

Some example values are:

V _{OUT}	R1	R2
1.2V	274k	294k
1.5V	316k	221k
1.8V	301k	158k
2.5V	324k	107k
3.3V	309k	71.5k

The Feed-forward capacitor, C4, is typically not fitted since transient load regulation is already very good, however, it can be improved slightly by fitting a capacitor

at C4 to inject fast output voltage deviations directly into the feedback comparator. This improved load regulation is at the expense of slightly increasing the amount of noise on the output at higher loads. Values between 100pF and 1nF are recommended to prevent instability.

Power Good (PG)

The evaluation board has a test point provided to the right of EN for testing PG. This is an open drain connection with an on board pull-up resistor of 10k to the output voltage. This is asserted high approximately 70μs after the output voltage passes 92% of the nominal set voltage.

HyperLight Load™ Mode

MIC23153 uses a minimum on and off time proprietary control loop (patented by Micrel). When the output voltage falls below the regulation threshold, the error comparator begins a switching cycle that turns the PMOS on and keeps it on for the duration of the minimum-on-time. This increases the output voltage. If the output voltage is over the regulation threshold, then the error comparator turns the PMOS off for a minimum-off-time until the output drops below the threshold. The NMOS acts as an ideal rectifier that conducts when the PMOS is off. Using a NMOS switch instead of a diode allows for lower voltage drop across the switching device when it is on. The asynchronous switching combination between the PMOS and the NMOS allows the control loop to work in discontinuous mode for light load operations. In discontinuous mode, the MIC23153 works in pulse frequency modulation (PFM) to regulate the output. As the output current increases, the off-time decreases, thus provides more energy to the output. This switching scheme improves the efficiency of MIC23153 during light load currents by only switching when it is needed. As the load current increases, the MIC23153 goes into continuous conduction mode (CCM) and switches at a frequency centered at 4MHz. The equation to calculate the load when the MIC23153 goes into continuous conduction mode may be approximated by the following formula:

$$I_{LOAD} > \left(\frac{(V_{IN} - V_{OUT}) \times D}{2L \times f} \right)$$

As shown in the previous equation, the load at which MIC23153 transitions from HyperLight Load™ mode to PWM mode is a function of the input voltage (V_{IN}), output voltage (V_{OUT}), duty cycle (D), inductance (L) and frequency (f). As shown in the Switching Frequency vs Load graph, as the Output Current increases, the switching frequency also increases until the MIC23153 goes from HyperLight Load™ mode to PWM mode at approximately 120mA. The MIC23153 will switch at a relatively constant frequency around 4MHz once the output current is over 120mA.

Evaluation Board Performance

Switching Frequency vs. Load Current

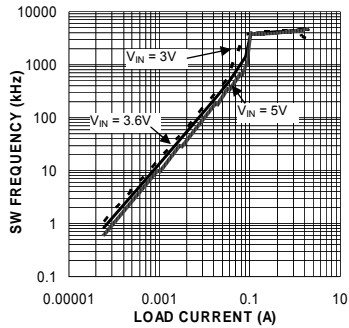

Efficiency vs. Output Current
 $V_{OUT} = 1.8V @ 25^{\circ}C$

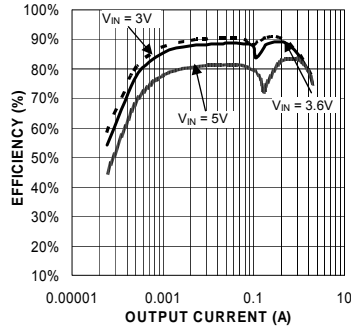

Efficiency vs. Output Current
 $V_{OUT} = 3.3V @ 25^{\circ}C$

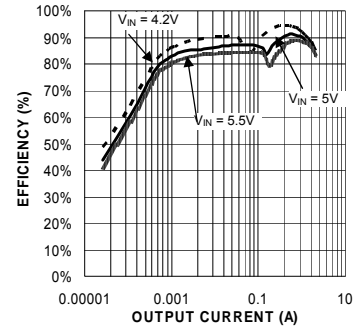

V_{OUT} Rise Time vs. C_{SS}

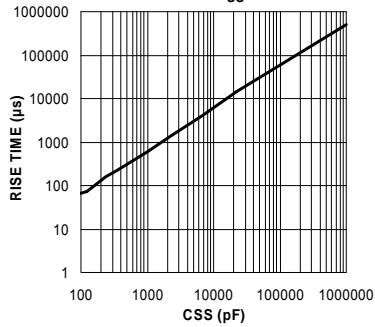

Enable Threshold vs. Input Voltage

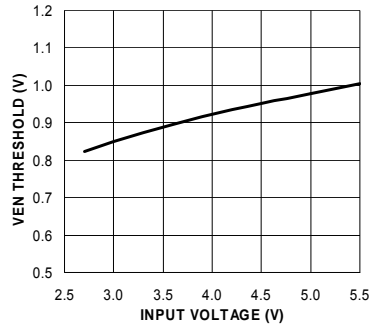

MIC23153-xYMT Evaluation Board Schematic (Fixed Output)

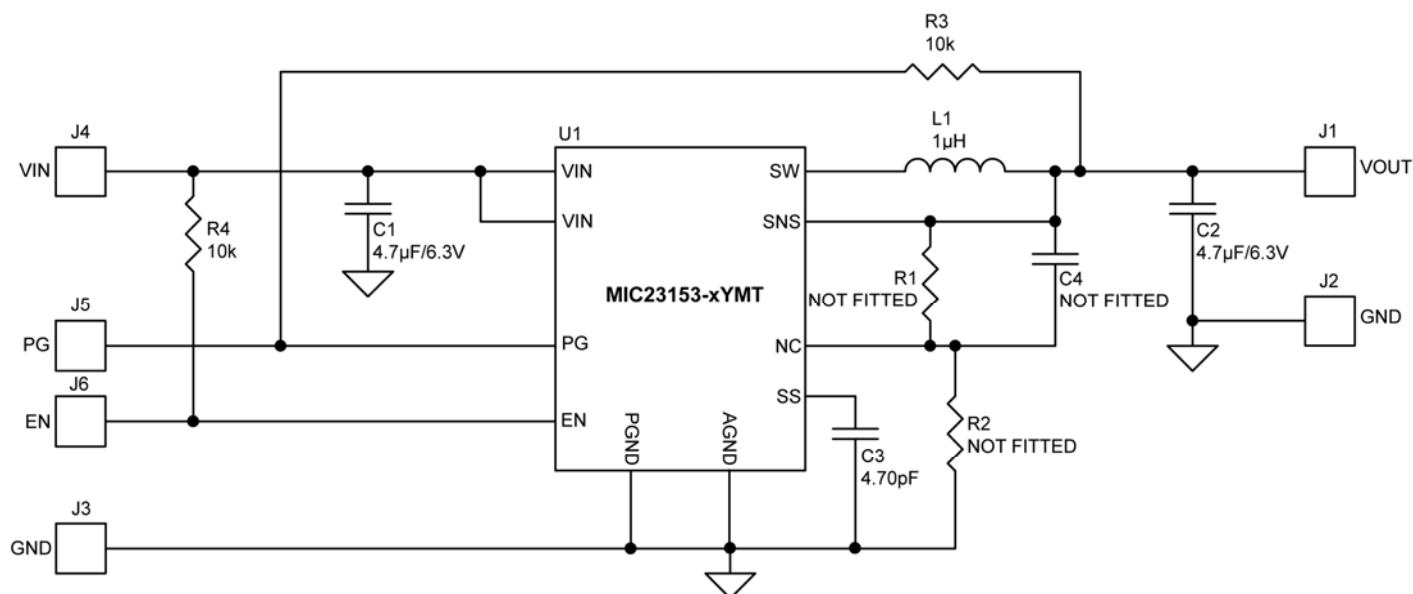

Bill of Materials

Item	Part Number	Manufacturer	Description	Qty.
C1	C1608X5R0J475K	TDK ⁽¹⁾	Ceramic Capacitor, 4.7µF, 6.3V, X5R, Size 0603	1
	GRM188R60J475KE19D	Murata ⁽²⁾		
C2	C1608X5R0J475K	TDK		1
	GRM188R60J475KE84D	Murata		
C3	C1608NPO0J471K	TDK	Ceramic Capacitor, 470pF, 6.3V, NPO, Size 0603	1
C4	-	-	Not Fitted (NF)	0
L1	VLS3012ST-1R0N1R9	TDK	1µH, 2A, 60mΩ, L3.0mm x W3.0mm x H1.0mm	1
	LQH44PN1R0NJ0	Murata	1µH, 2.8A, 50mΩ, L4.0mm x W4.0mm x H1.2mm	
R1	-	-	Not Fitted (NF)	0
R2	-	-	Not Fitted (NF)	0
R3	CRCW06031002FKEA	Vishay ⁽³⁾	Resistor, 10k, Size 0603	1
R4	CRCW06031002FKEA	Vishay	Resistor, 10k, Size 0603	1
U1	MIC23153-xYMT	Micrel, Inc. ⁽⁴⁾	4MHz 2A Buck Regulator with HyperLight Load™ Mode	1

Notes:

1. TDK: www.tdk.com.
2. Murata: www.murata.com.
3. Vishay: www.vishay.com.
4. Micrel, Inc.: www.micrel.com.

MIC23153 Evaluation Board Schematic (Adjustable Output)

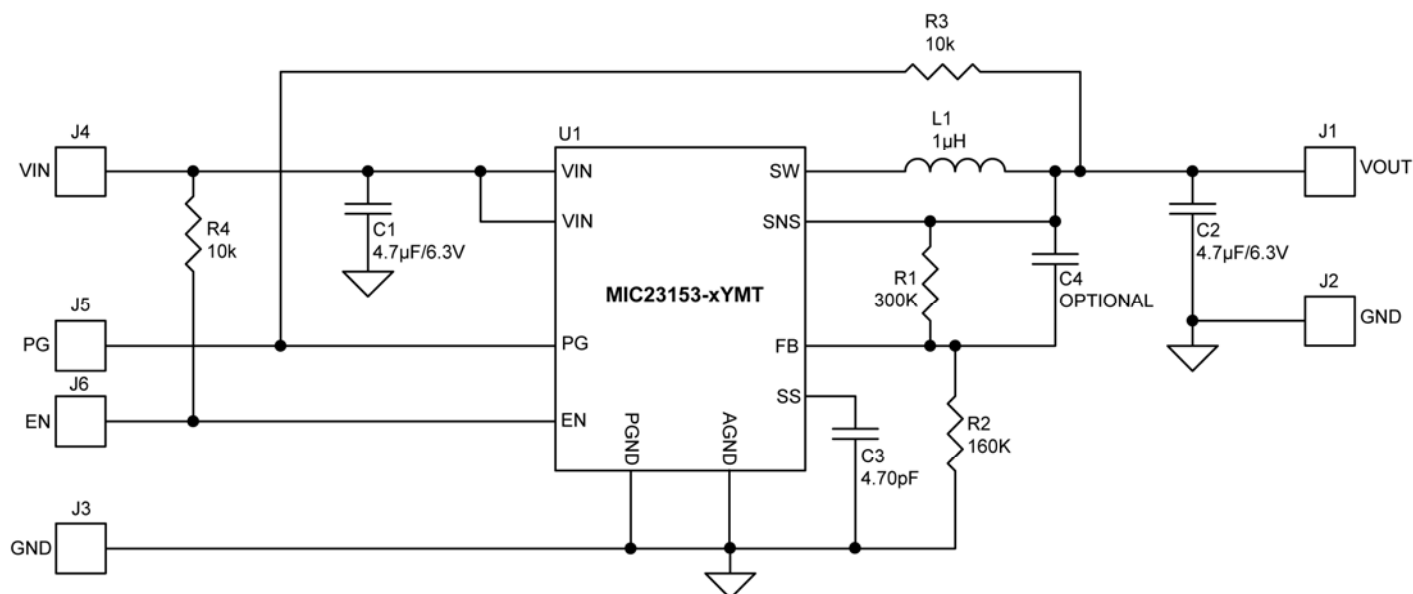

Bill of Materials

Item	Part Number	Manufacturer	Description	Qty.
C1	C1608X5R0J475K	TDK ⁽¹⁾	Ceramic Capacitor, 4.7µF, 6.3V, X5R, Size 0603	1
	GRM188R60J475KE19D	Murata ⁽²⁾		
C2	C1608X5R0J475K	TDK		1
	GRM188R60J475KE84D	Murata		
C3	C1608NPO0J471K	TDK	Ceramic Capacitor, 470pF, 6.3V, NPO, Size 0603	1
C4	-	-	Not Fitted (FT)	0
L1	VLS3010ST-1R0N1R9	TDK	1µH, 2A, 60mΩ, L3.0mm x W3.0mm x H1.0mm	1
	LQH44PN1R0NJ0	Murata ⁽²⁾	1µH, 2.8A, 50mΩ, L4.0mm x W4.0mm x H1.2mm	
R1	CRCW06033013FKEA	Vishay ⁽³⁾	Resistor, 301k, Size 0603	1
R2	CRCW06031583FKEA	Vishay	Resistor, 158k, Size 0603	1
R3	CRCW06031002FKEA	Vishay	Resistor, 10k, Size 0603	1
R4	CRCW06031002FKEA	Vishay	Resistor, 10k, Size 0603	1
U1	MIC23153YMT	Micrel, Inc. ⁽⁴⁾	4MHz 2A Buck Regulator with HyperLight Load™ Mode	1

Notes:

1. TDK: www.tdk.com.
2. Murata: www.murata.com.
3. Vishay: www.vishay.com.
4. Micrel, Inc.: www.micrel.com.

PCB Layout Recommendations

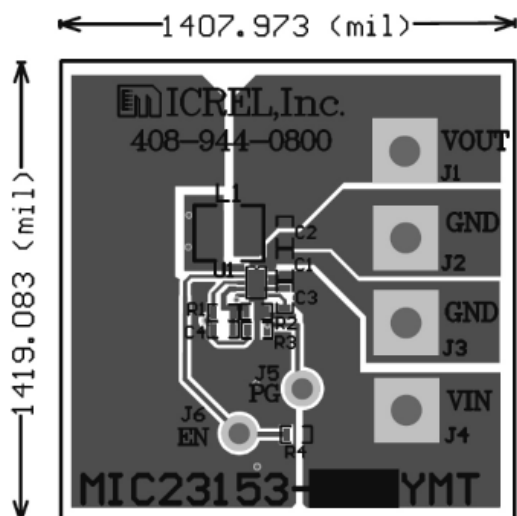

Thin MLF Top Layer

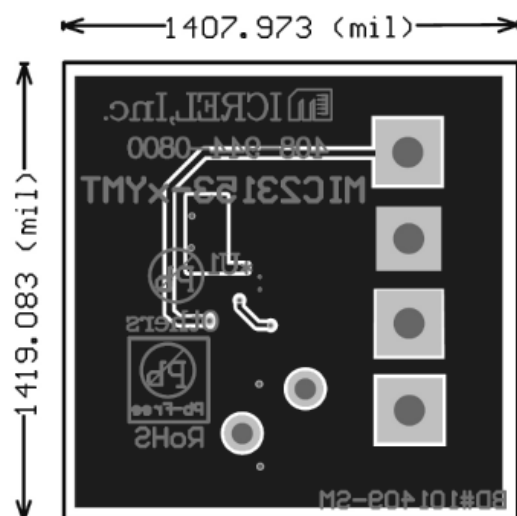

Thin MLF Bottom Layer

MICREL, INC. 2180 FORTUNE DRIVE SAN JOSE, CA 95131 USA
 TEL +1 (408) 944-0800 FAX +1 (408) 474-1000 WEB <http://www.micrel.com>

The information furnished by Micrel in this data sheet is believed to be accurate and reliable. However, no responsibility is assumed by Micrel for its use. Micrel reserves the right to change circuitry and specifications at any time without notification to the customer.

Micrel Products are not designed or authorized for use as components in life support appliances, devices or systems where malfunction of a product can reasonably be expected to result in personal injury. Life support devices or systems are devices or systems that (a) are intended for surgical implant into the body or (b) support or sustain life, and whose failure to perform can be reasonably expected to result in a significant injury to the user. A Purchaser's use or sale of Micrel Products for use in life support appliances, devices or systems is a Purchaser's own risk and Purchaser agrees to fully indemnify Micrel for any damages resulting from such use or sale.

© 2010 Micrel, Incorporated.

Mouser Electronics

Authorized Distributor

Click to View Pricing, Inventory, Delivery & Lifecycle Information:

[Micrel:](#)

[MIC23153YMT-EV](#)

Компания «Океан Электроники» предлагает заключение долгосрочных отношений при поставках импортных электронных компонентов на взаимовыгодных условиях!

Наши преимущества:

- Поставка оригинальных импортных электронных компонентов напрямую с производств Америки, Европы и Азии, а так же с крупнейших складов мира;
- Широкая линейка поставок активных и пассивных импортных электронных компонентов (более 30 млн. наименований);
- Поставка сложных, дефицитных, либо снятых с производства позиций;
- Оперативные сроки поставки под заказ (от 5 рабочих дней);
- Экспресс доставка в любую точку России;
- Помощь Конструкторского Отдела и консультации квалифицированных инженеров;
- Техническая поддержка проекта, помощь в подборе аналогов, поставка прототипов;
- Поставка электронных компонентов под контролем ВП;
- Система менеджмента качества сертифицирована по Международному стандарту ISO 9001;
- При необходимости вся продукция военного и аэрокосмического назначения проходит испытания и сертификацию в лаборатории (по согласованию с заказчиком);
- Поставка специализированных компонентов военного и аэрокосмического уровня качества (Xilinx, Altera, Analog Devices, Intersil, Interpoint, Microsemi, Actel, Aeroflex, Peregrine, VPT, Syfer, Eurofarad, Texas Instruments, MS Kennedy, Miteq, Cobham, E2V, MA-COM, Hittite, Mini-Circuits, General Dynamics и др.);

Компания «Океан Электроники» является официальным дистрибьютором и эксклюзивным представителем в России одного из крупнейших производителей разъемов военного и аэрокосмического назначения «JONHON», а так же официальным дистрибьютором и эксклюзивным представителем в России производителя высокотехнологичных и надежных решений для передачи СВЧ сигналов «FORSTAR».



JONHON

«JONHON» (основан в 1970 г.)

Разъемы специального, военного и аэрокосмического назначения:

(Применяются в военной, авиационной, аэрокосмической, морской, железнодорожной, горно- и нефтедобывающей отраслях промышленности)

«FORSTAR» (основан в 1998 г.)

ВЧ соединители, коаксиальные кабели, кабельные сборки и микроволновые компоненты:

(Применяются в телекоммуникациях гражданского и специального назначения, в средствах связи, РЛС, а так же военной, авиационной и аэрокосмической отраслях промышленности).



Телефон: 8 (812) 309-75-97 (многоканальный)

Факс: 8 (812) 320-03-32

Электронная почта: ocean@oceanchips.ru

Web: <http://oceanchips.ru/>

Адрес: 198099, г. Санкт-Петербург, ул. Калинина, д. 2, корп. 4, лит. А