

## Description

The AP22800 is an integrated N-channel load switch, which features an adjustable ramp-up and discharge rate that are settable via an external capacitor and a resistor, respectively. In addition, it incorporates a 'power good' output to flag when the switch is enhanced. The N-channel MOSFET has a typical  $R_{DS(ON)}$  of 16m $\Omega$ , enabling current handling capability of up to 4A.

The AP22800 is designed to operate from 1.5V to 5.5V making it ideal for 1.8V, 2.5V, 3.3V, 5V voltage rails. The low quiescent supply current specification of 21 $\mu$ A makes it ideal for use in battery powered distribution systems where power consumption is a concern.

The AP22800 is available in a standard Green U-DFN2116-8 package with an exposed PAD for improved thermal performance and is RoHS compliant.

## Features

- 1.5V to 5.5V Input Range
- Low Typical  $R_{DS(ON)}$  of 16m $\Omega$
- Very Low Quiescent Current of 21 $\mu$ A
- Adjustable Start-Up and Discharge Rate
- Small Form Factor Package U-DFN2116-8  
– Footprint of just 3.36mm<sup>2</sup>
- Thermally Efficient Low Profile
- **Totally Lead-Free & Fully RoHS Compliant (Notes 1 & 2)**
- **Halogen and Antimony Free. "Green" Device (Note 3)**

## Pin Assignments

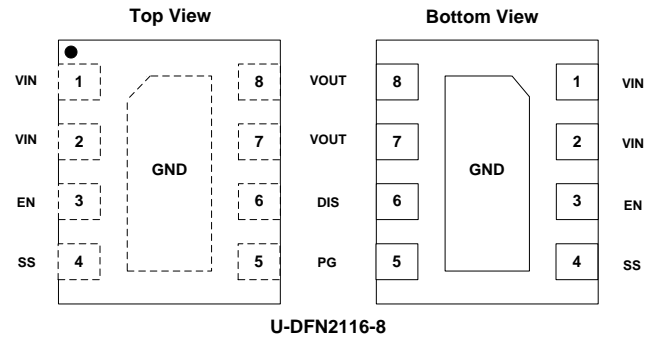

## Applications

- Integrated Load Switches in Ultrabook PCs
- Power Up/Down Sequencing in Ultrabook PCs
- Tablets
- SSD (Solid State Drives)
- Consumer Electronics
- Telecom Systems
- Set-top Boxes
- E-Readers

- Notes:
1. No purposely added lead. Fully EU Directive 2002/95/EC (RoHS) & 2011/65/EU (RoHS 2) compliant.
  2. See [http://www.diodes.com/quality/lead\\_free.html](http://www.diodes.com/quality/lead_free.html) for more information about Diodes Incorporated's definitions of Halogen- and Antimony-free, "Green" and Lead-free.
  3. Halogen- and Antimony-free "Green" products are defined as those which contain <900ppm bromine, <900ppm chlorine (<1500ppm total Br + Cl) and <1000ppm antimony compounds.

## Typical Applications Circuit

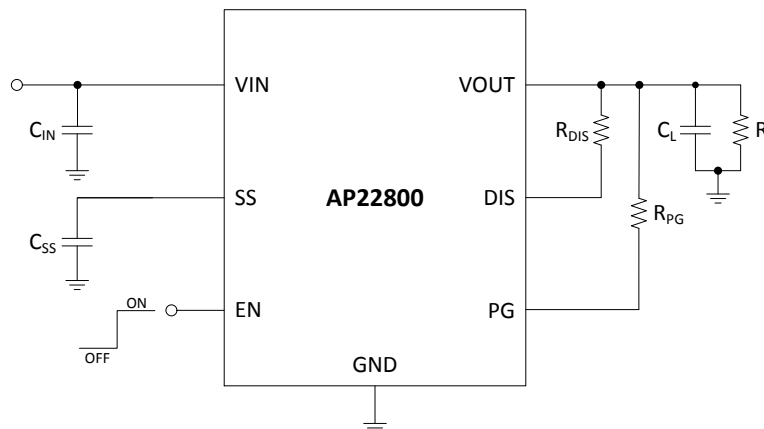

## Pin Descriptions

Pin Name	Pin Number	Function
VIN	1, 2	Input Voltage.
EN	3	Enable Input, Active High.
SS	4	Soft-Start Adjust. An external capacitor connected to this pin will set the ramp-up time of VOUT.
PG	5	Power Good. Open-drain output to indicate when the switch is fully enhanced.
DIS	6	Output Discharge. An external resistor between DIS and VOUT sets the discharge rate at VOUT when EN goes low.
VOUT	7, 8	Output Voltage. This pin connects to the Source of the N-channel MOSFET.
GND	PAD	Ground.

## Functional Block Diagram

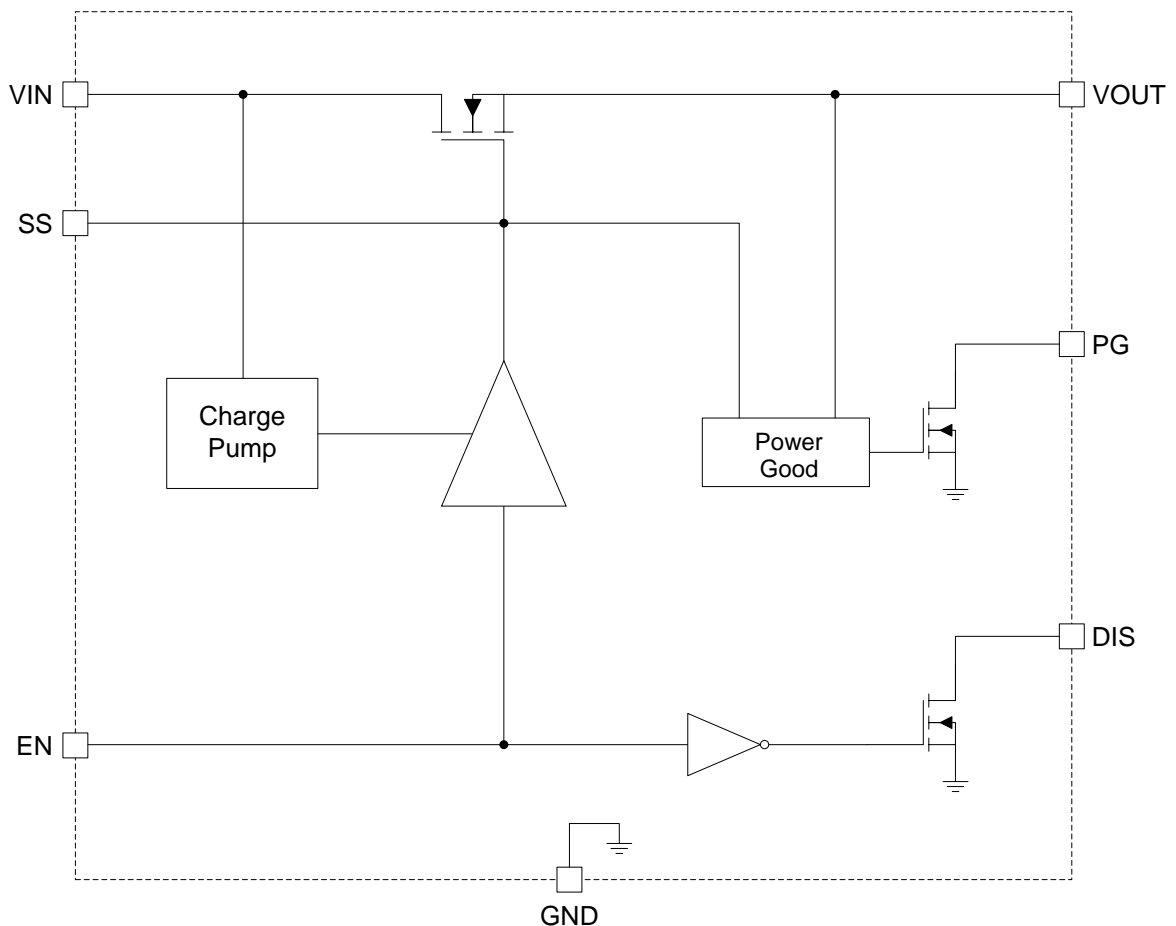

### Absolute Maximum Ratings (@T<sub>A</sub> = +25°C, unless otherwise specified.) (Note 4)

Symbol	Parameter	Ratings	Units
ESD HBM	Human Body ESD Protection	2000	V
ESD MM	Machine Model ESD Protection	200	V
V <sub>IN</sub>	Input Voltage	6.0	V
V <sub>OUT</sub>	Output Voltage	6.0	V
V <sub>EN</sub>	Enable Voltage	6.0	V
I <sub>L</sub>	Load Current	4.0	A
T <sub>J(max)</sub>	Maximum Junction Temperature	+125	°C
T <sub>ST</sub>	Storage Temperature	-55 to +150	°C
P <sub>D</sub>	Power Dissipation	(Note 5)	0.35
		(Note 6)	1.42
R <sub>θJA</sub>	Thermal Resistance, Junction to Ambient	(Note 5)	290
		(Note 6)	71
R <sub>θJC</sub>	Thermal Resistance, Junction to Case	8.5	°C/W

- Notes:
- Stresses greater than the 'Absolute Maximum Ratings' specified above may cause permanent damage to the device. These are stress ratings only; functional operation of the device at these or any other conditions exceeding those indicated in this specification is not implied. Device reliability may be affected by exposure to absolute maximum rating conditions for extended periods of time.
  - For a device surface mounted on minimum recommended pad layout, in still air conditions; the device is measured when operating in a steady state condition.
  - For a device surface mounted on 25mm by 25mm by 1.6mm FR4 PCB with high coverage of single sided 2oz copper, in still air conditions; the device is measured when operating in a steady state condition.

### Recommended Operating Conditions (@T<sub>A</sub> = +25°C, unless otherwise specified.)

Symbol	Parameter	Min	Max	Units
V <sub>IN</sub>	Input Voltage Range	1.5	5.5	V
V <sub>EN</sub>	Enable Voltage Range	0	5.5	V
V <sub>PG</sub>	Power Good Voltage Range	0	5.5	V
T <sub>A</sub>	Operating Ambient Temperature	-40	+85	°C

**Electrical Characteristics** (@T<sub>A</sub> = +25°C, C<sub>IN</sub> = 1μF, C<sub>L</sub> = 100nF, unless otherwise specified.)

V <sub>IN</sub> = 5.0V						
Symbol	Parameters	Conditions	Min	Typ	Max	Unit
I <sub>IN_Q</sub>	Input Quiescent Current	V <sub>EN</sub> = V <sub>IN</sub> , I <sub>OUT</sub> = 0A	–	21	35	μA
I <sub>IN_SD</sub>	Input Shutdown Current	V <sub>EN</sub> = 0V, I <sub>OUT</sub> = 0A, R <sub>DIS</sub> = 240Ω	–	0.05	0.5	μA
R <sub>DS(ON)</sub>	Load Switch On-Resistance	V <sub>EN</sub> = V <sub>IN</sub> , I <sub>OUT</sub> = -1A	–	16	21	mΩ
V <sub>IH_EN</sub>	EN Input Logic High Voltage	–	1.0	–	–	V
V <sub>IL_EN</sub>	EN Input Logic Low Voltage	–	–	–	0.5	V
I <sub>LEAK_EN</sub>	EN Input Leakage	V <sub>EN</sub> = V <sub>IN</sub>	–	–	0.1	μA
R <sub>DS_DIS</sub>	Discharge FET On-Resistance	V <sub>EN</sub> = 0V, I <sub>DIS</sub> = 10mA	–	4	6	Ω
V <sub>OL_PG</sub>	Power Good Output Low Level	I <sub>OL_PG</sub> = 100μA, V <sub>EN</sub> = 0V	–	–	0.2	V
I <sub>oZ_PG</sub>	Power Good High-Impedance Current	V <sub>PG</sub> = V <sub>IN</sub> , V <sub>EN</sub> = V <sub>IN</sub>	–	–	0.05	μA
t <sub>RISE</sub>	Output Rise Time	R <sub>L</sub> = 10Ω, C <sub>SS</sub> = 10nF	–	130	–	μs
t <sub>ON</sub>	Output Turn-ON Delay Time	R <sub>L</sub> = 10Ω, C <sub>SS</sub> = 10nF	–	90	–	μs
t <sub>FALL</sub>	Output Fall Time	R <sub>L</sub> = Open, R <sub>DIS</sub> = 240Ω, C <sub>SS</sub> = 10nF	–	55	–	μs
t <sub>OFF</sub>	Output Turn-OFF Delay Time	R <sub>L</sub> = Open, R <sub>DIS</sub> = 240Ω, C <sub>SS</sub> = 10nF	–	21	–	μs
t <sub>D</sub>	Output Start Delay Time	R <sub>L</sub> = 10Ω, C <sub>SS</sub> = 10nF (Note 7)	–	20	–	μs
t <sub>PG</sub>	Power Good Delay Time	R <sub>L</sub> = 10Ω, C <sub>SS</sub> = 10nF	–	410	–	μs

V <sub>IN</sub> = 3.3V						
Symbol	Parameters	Conditions	Min	Typ	Max	Unit
I <sub>IN_Q</sub>	Input Quiescent Current	V <sub>EN</sub> = V <sub>IN</sub> , I <sub>OUT</sub> = 0A	–	13	23	μA
I <sub>IN_SD</sub>	Input Shutdown Current	V <sub>EN</sub> = 0V, I <sub>OUT</sub> = 0A, R <sub>DIS</sub> = 240Ω	–	0.04	0.2	μA
R <sub>DS(ON)</sub>	Load Switch On-Resistance	V <sub>EN</sub> = V <sub>IN</sub> , I <sub>OUT</sub> = -1A	–	17	22	mΩ
V <sub>IH_EN</sub>	EN Input Logic High Voltage	–	1.0	–	–	V
V <sub>IL_EN</sub>	EN Input Logic Low Voltage	–	–	–	0.5	V
I <sub>LEAK_EN</sub>	EN Input Leakage	V <sub>EN</sub> = V <sub>IN</sub>	–	–	0.1	μA
R <sub>DS_DIS</sub>	Discharge FET On-Resistance	V <sub>EN</sub> = 0V, I <sub>DIS</sub> = 10mA	–	5	8	Ω
V <sub>OL_PG</sub>	Power Good Output Low Level	I <sub>OL_PG</sub> = 100μA, V <sub>EN</sub> = 0V	–	–	0.2	V
I <sub>oZ_PG</sub>	Power Good High-Impedance Current	V <sub>PG</sub> = V <sub>IN</sub> , V <sub>EN</sub> = V <sub>IN</sub>	–	–	0.05	μA
t <sub>RISE</sub>	Output Rise Time	R <sub>L</sub> = 10Ω, C <sub>SS</sub> = 10nF	–	130	–	μs
t <sub>ON</sub>	Output Turn-ON Delay Time	R <sub>L</sub> = 10Ω, C <sub>SS</sub> = 10nF	–	90	–	μs
t <sub>FALL</sub>	Output Fall Time	R <sub>L</sub> = Open, R <sub>DIS</sub> = 240Ω, C <sub>SS</sub> = 10nF	–	55	–	μs
t <sub>OFF</sub>	Output Turn-OFF Delay Time	R <sub>L</sub> = Open, R <sub>DIS</sub> = 240Ω, C <sub>SS</sub> = 10nF	–	21	–	μs
t <sub>D</sub>	Output Start Delay Time	R <sub>L</sub> = 10Ω, C <sub>SS</sub> = 10nF (Note 7)	–	25	–	μs
t <sub>PG</sub>	Power Good Delay Time	R <sub>L</sub> = 10Ω, C <sub>SS</sub> = 10nF	–	340	–	μs

**Electrical Characteristics** (Cont. @  $T_A = +25^\circ\text{C}$ ,  $C_{IN} = 1\mu\text{F}$ ,  $C_L = 100\text{nF}$ , unless otherwise specified.)

$V_{IN} = 2.5\text{V}$						
Symbol	Parameters	Conditions	Min	Typ	Max	Unit
$I_{IN\_Q}$	Input Quiescent Current	$V_{EN} = V_{IN}$ , $I_{OUT} = 0\text{A}$	–	11	19	$\mu\text{A}$
$I_{IN\_SD}$	Input Shutdown Current	$V_{EN} = 0\text{V}$ , $I_{OUT} = 0\text{A}$ , $R_{DIS} = 240\Omega$	–	0.04	0.2	$\mu\text{A}$
$R_{DS(ON)}$	Load Switch On-Resistance	$V_{EN} = V_{IN}$ , $I_{OUT} = -1\text{A}$	–	19	24	$\text{m}\Omega$
$V_{IH\_EN}$	EN Input Logic High Voltage	–	1.0	–	–	V
$V_{IL\_EN}$	EN Input Logic Low Voltage	–	–	–	0.5	V
$I_{LEAK\_EN}$	EN Input Leakage	$V_{EN} = V_{IN}$	–	–	0.1	$\mu\text{A}$
$R_{DS\_DIS}$	Discharge FET On-Resistance	$V_{EN} = 0\text{V}$ , $I_{DIS} = 10\text{mA}$	–	6	9	$\Omega$
$V_{OL\_PG}$	Power Good Output Low Level	$I_{OL\_PG} = 100\mu\text{A}$ , $V_{EN} = 0\text{V}$	–	–	0.2	V
$I_{OZ\_PG}$	Power Good High-Impedance Current	$V_{PG} = V_{IN}$ , $V_{EN} = V_{IN}$	–	–	0.05	$\mu\text{A}$
$t_{RISE}$	Output Rise Time	$R_L = 10\Omega$ , $C_{SS} = 10\text{nF}$	–	125	–	$\mu\text{s}$
$t_{ON}$	Output Turn-ON Delay Time	$R_L = 10\Omega$ , $C_{SS} = 10\text{nF}$	–	95	–	$\mu\text{s}$
$t_{FALL}$	Output Fall Time	$R_L = \text{Open}$ , $R_{DIS} = 240\Omega$ , $C_{SS} = 10\text{nF}$	–	56	–	$\mu\text{s}$
$t_{OFF}$	Output Turn-OFF Delay Time	$R_L = \text{Open}$ , $R_{DIS} = 240\Omega$ , $C_{SS} = 10\text{nF}$	–	21	–	$\mu\text{s}$
$t_D$	Output Start Delay Time	$R_L = 10\Omega$ , $C_{SS} = 10\text{nF}$ (Note 7)	–	30	–	$\mu\text{s}$
$t_{PG}$	Power Good Delay Time	$R_L = 10\Omega$ , $C_{SS} = 10\text{nF}$	–	310	–	$\mu\text{s}$

$V_{IN} = 1.8\text{V}$						
Symbol	Parameters	Conditions	Min	Typ	Max	Unit
$I_{IN\_Q}$	Input Quiescent Current	$V_{EN} = V_{IN}$ , $I_{OUT} = 0\text{A}$	–	9	16	$\mu\text{A}$
$I_{IN\_SD}$	Input Shutdown Current	$V_{EN} = 0\text{V}$ , $I_{OUT} = 0\text{A}$ , $R_{DIS} = 240\Omega$	–	0.03	0.2	$\mu\text{A}$
$R_{DS(ON)}$	Load Switch On-Resistance	$V_{EN} = V_{IN}$ , $I_{OUT} = -1\text{A}$	–	22	28	$\text{m}\Omega$
$V_{IH\_EN}$	EN Input Logic High Voltage	–	0.9	–	–	V
$V_{IL\_EN}$	EN Input Logic Low Voltage	–	–	–	0.4	V
$I_{LEAK\_EN}$	EN Input Leakage	$V_{EN} = V_{IN}$	–	–	0.1	$\mu\text{A}$
$R_{DS\_DIS}$	Discharge FET On-Resistance	$V_{EN} = 0\text{V}$ , $I_{DIS} = 10\text{mA}$	–	8	12	$\Omega$
$V_{OL\_PG}$	Power Good Output Low Level	$I_{OL\_PG} = 100\mu\text{A}$ , $V_{EN} = 0\text{V}$	–	–	0.2	V
$I_{OZ\_PG}$	Power Good High-Impedance Current	$V_{PG} = V_{IN}$ , $V_{EN} = V_{IN}$	–	–	0.05	$\mu\text{A}$
$t_{RISE}$	Output Rise Time	$R_L = 10\Omega$ , $C_{SS} = 10\text{nF}$	–	130	–	$\mu\text{s}$
$t_{ON}$	Output Turn-ON Delay Time	$R_L = 10\Omega$ , $C_{SS} = 10\text{nF}$	–	100	–	$\mu\text{s}$
$t_{FALL}$	Output Fall Time	$R_L = \text{Open}$ , $R_{DIS} = 240\Omega$ , $C_{SS} = 10\text{nF}$	–	56	–	$\mu\text{s}$
$t_{OFF}$	Output Turn-OFF Delay Time	$R_L = \text{Open}$ , $R_{DIS} = 240\Omega$ , $C_{SS} = 10\text{nF}$	–	21	–	$\mu\text{s}$
$t_D$	Output Start Delay Time	$R_L = 10\Omega$ , $C_{SS} = 10\text{nF}$ (Note 7)	–	40	–	$\mu\text{s}$
$t_{PG}$	Power Good Delay Time	$R_L = 10\Omega$ , $C_{SS} = 10\text{nF}$	–	300	–	$\mu\text{s}$

Note: 7. Guaranteed by design

**Test Circuit and  $t_{ON}/t_{OFF}$  Waveforms**

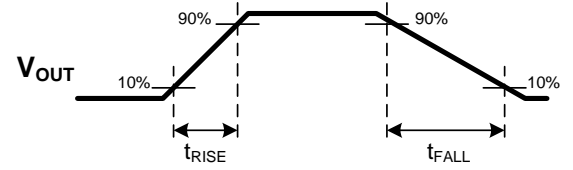
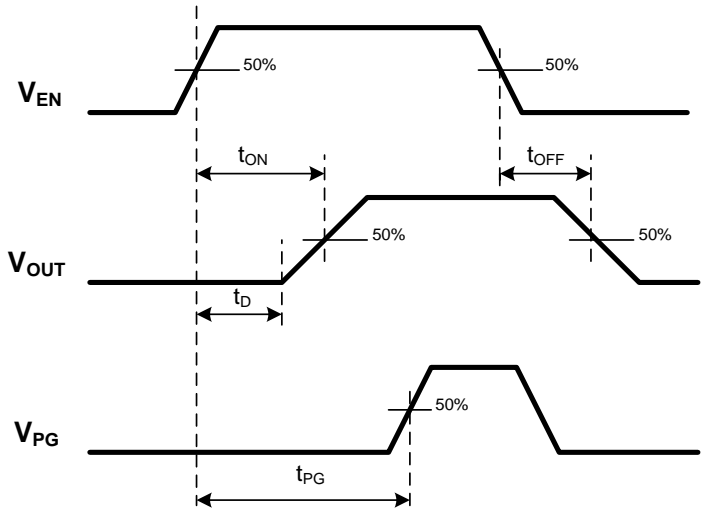

NEW PRODUCT

**Performance Characteristics** (@ $T_A = +25^\circ\text{C}$ ,  $V_{IN} = 5\text{V}$ , unless otherwise specified.)

**$R_{DS(ON)}$  vs.  $V_{IN}$  ( $I_{OUT}=200\text{mA}$ )**

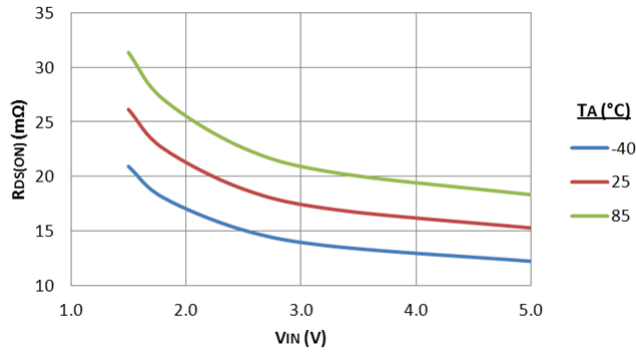

**$R_{DS(ON)}$  vs. Ambient Temperature ( $I_{OUT}=200\text{mA}$ )**

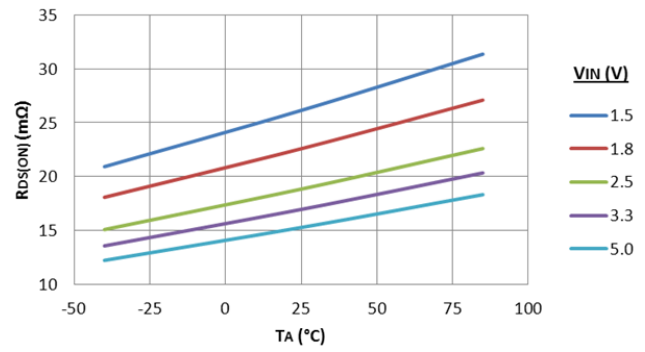

**Input Quiescent Current vs.  $V_{IN}$**

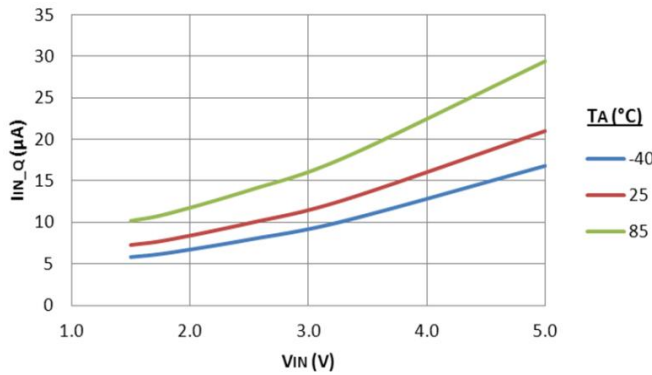

**Input Shutdown Current vs.  $V_{IN}$**

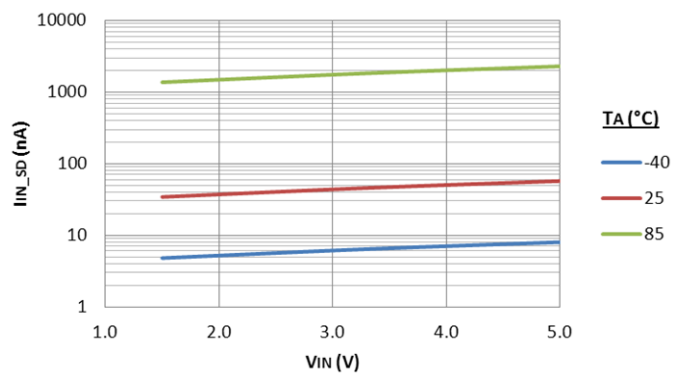

**Turn On Response Time**

( $V_{IN}=5\text{V}$ ,  $T_A=+25^\circ\text{C}$ ,  $R_L=10\Omega$ ,  $C_{SS}=10\text{nF}$ ,  $C_L=1\mu\text{F}$ ,  $C_{IN}=1\mu\text{F}$ )

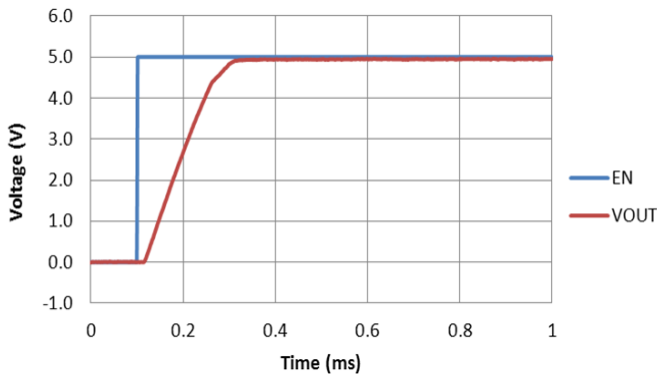

**Turn Off Response Time**

( $V_{IN}=5\text{V}$ ,  $T_A=+25^\circ\text{C}$ ,  $R_{DIS}=1\text{k}\Omega$ ,  $C_{SS}=10\text{nF}$ ,  $C_L=1\mu\text{F}$ ,  $C_{IN}=1\mu\text{F}$ )

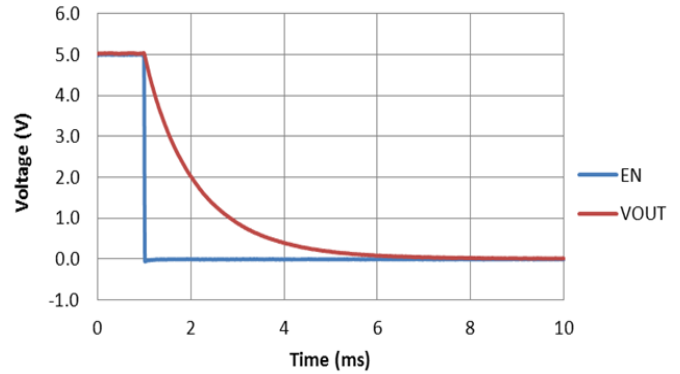

**Performance Characteristics** (Cont. @  $T_A = +25^\circ\text{C}$ ,  $V_{IN} = 5\text{V}$ , unless otherwise specified.)

**Turn On Response Time**

( $V_{IN}=1.5\text{V}$ ,  $R_L=10\Omega$ ,  $C_{SS}=10\text{nF}$ ,  $C_L=1\mu\text{F}$ ,  $C_{IN}=1\mu\text{F}$ )

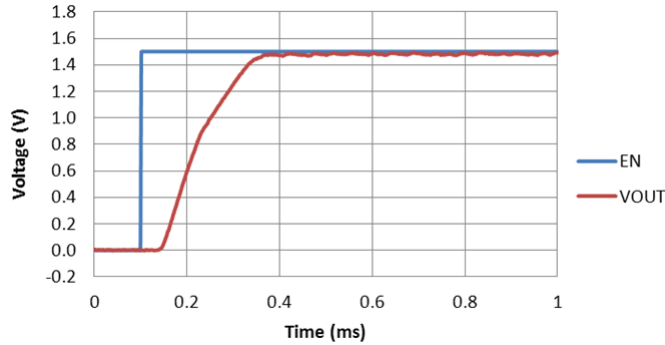

**Turn Off Response Time**

( $V_{IN}=1.5\text{V}$ ,  $T_A=+25^\circ\text{C}$ ,  $R_{DIS}=1\text{k}\Omega$ ,  $C_{SS}=10\text{nF}$ ,  $C_L=1\mu\text{F}$ ,  $C_{IN}=1\mu\text{F}$ )

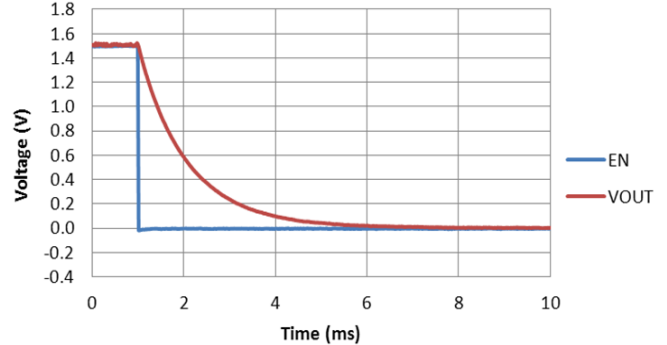

**$t_{RISE}$  vs.  $V_{IN}$**

( $T_A=+25^\circ\text{C}$ ,  $R_L=10\Omega$ ,  $C_{SS}=10\text{nF}$ ,  $C_L=1\mu\text{F}$ ,  $C_{IN}=1\mu\text{F}$ )

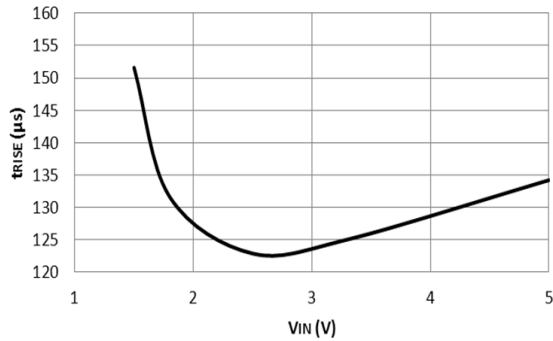

**$t_D$  vs.  $V_{IN}$**

( $T_A=+25^\circ\text{C}$ ,  $R_L=10\Omega$ ,  $C_{SS}=10\text{nF}$ ,  $C_L=1\mu\text{F}$ ,  $C_{IN}=1\mu\text{F}$ )

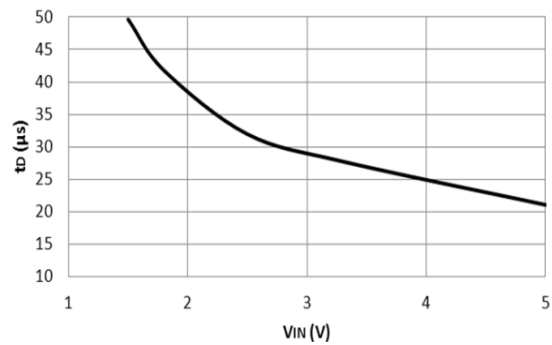

**$t_{FALL}$  vs.  $V_{IN}$**

( $T_A=+25^\circ\text{C}$ ,  $R_{DIS}=1\text{k}\Omega$ ,  $C_{SS}=10\text{nF}$ ,  $C_L=1\mu\text{F}$ ,  $C_{IN}=1\mu\text{F}$ )

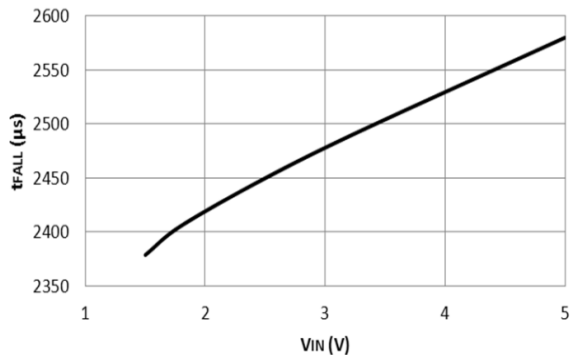

**$t_{FALL}$  vs.  $V_{IN}$**

( $T_A=+25^\circ\text{C}$ ,  $R_{DIS}=240\Omega$ ,  $C_{SS}=10\text{nF}$ ,  $C_L=0.1\mu\text{F}$ ,  $C_{IN}=1\mu\text{F}$ )

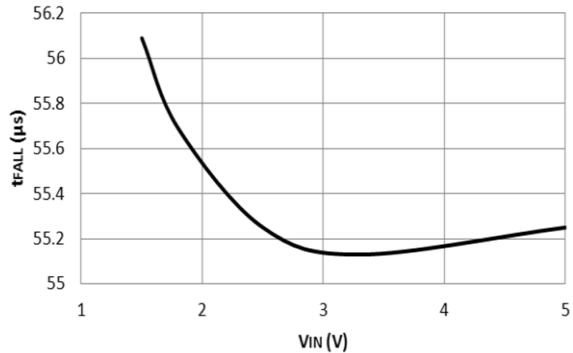

NEW PRODUCT

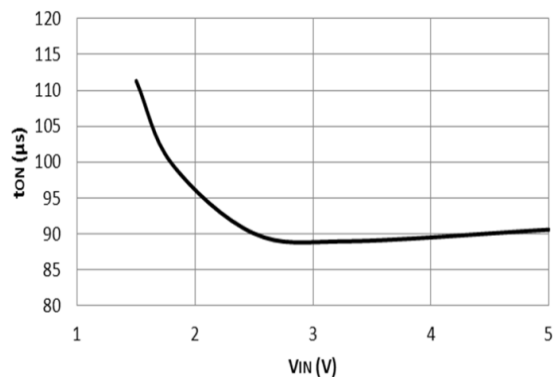
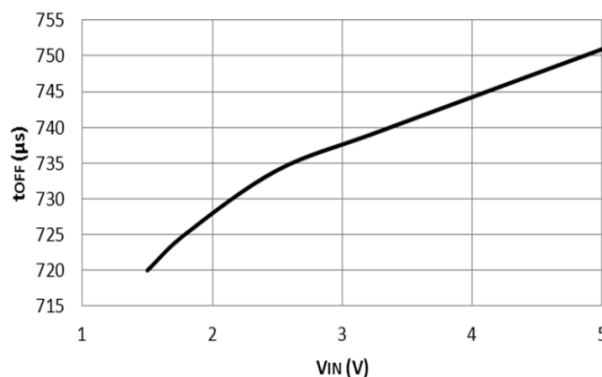

**Performance Characteristics** (Cont. @  $T_A = +25^\circ\text{C}$ ,  $V_{IN} = 5\text{V}$ , unless otherwise specified.)

 **$t_{ON}$  vs.  $V_{IN}$**   
 ( $T_A = +25^\circ\text{C}$ ,  $R_L = 10\Omega$ ,  $C_{SS} = 10\text{nF}$ ,  $C_L = 1\mu\text{F}$ ,  $C_{IN} = 1\mu\text{F}$ )

 **$t_{OFF}$  vs.  $V_{IN}$**   
 ( $T_A = +25^\circ\text{C}$ ,  $R_{DIS} = 1\text{k}\Omega$ ,  $C_{SS} = 10\text{nF}$ ,  $C_L = 1\mu\text{F}$ ,  $C_{IN} = 1\mu\text{F}$ )

**Application Information**
**Theory of Operation**

The AP22800 is a load switch that can be used to isolate or power-down part of a system in order to reduce power consumption, particularly in battery-powered devices. The NMOS pass element in the AP22800 is turned on when EN pin is pulled high. This enables the internal charge pump, which then increases the voltage on the SS pin and provides an overdrive on the gate of the N-channel pass switch.

When the voltage on the gate of the pass switch is around 1.6 times greater than  $V_{IN}$ , power is deemed to be good, and the Power Good (PG) output is pulled high via an external pull-up resistor. The rise-time of the switch is controlled by the value of the capacitor on the SS pin.

When EN is pulled low, the NMOS pass switch turns off and isolates  $V_{OUT}$  from  $V_{IN}$ . In addition, PG is pulled to ground to indicate that the power is no longer good. The DIS pin keeps  $V_{OUT}$  grounded while EN is low. The fall time on  $V_{OUT}$  is largely controlled by the value of the discharge resistor and the capacitance on the output.

**Input and Output Voltage**

The Input Voltage ( $V_{IN}$ ) should be between 1.5V and 5.5V. With the switch activated, the Output Voltage ( $V_{OUT}$ ) will be the input voltage minus the voltage drop across the device.

**Enable**

The GPIO compatible EN input allows the output current to be switched on and off. A high signal (switch on) should be at least 1V, and a low signal (switch off) no higher than 0.5V. The EN pin should not be left floating. It is advisable to hold EN low when applying or removing power.

**Power Good**

The PG output is an open drain output that indicates when the pass switch is enhanced enough to deliver current to the load. When the gate voltage rises to  $V_{IN} \times 1.6$ , PG is pulled high via the external pull-up resistor. For example, if  $V_{IN} = 5\text{V}$ , then PG goes high when the gate voltage of the pass switch reaches 8V, thus, providing an overdrive of 3V. PG is pulled low when power is deemed not to be good.

PG can be pulled up to any voltage to a maximum of 5.5V, although it is recommended to utilize  $V_{OUT}$  with a resistor greater than 50k $\Omega$ . The advantage of pulling up PG to  $V_{OUT}$  is that when EN is low,  $V_{OUT}$  is also grounded. Thus, no power is wasted in the pull-up resistor.

If this feature is not required, then PG pin can be left floating.

**Input and Output Capacitors**

The input and output capacitors should be placed as close to  $V_{IN}$  and  $V_{OUT}$  pins as possible. The output capacitor should not be greater than the input capacitor, otherwise, current may flow backwards through the device after turn off. Typically, a 10 $\mu\text{F}$  input capacitor and a 1 $\mu\text{F}$  output capacitor should be placed close to  $V_{IN}$  and  $V_{OUT}$  pins.

## Application Information (Cont.)

For heavier loads, it is recommended that the VIN and VOUT trace lengths be kept to a minimum. In addition, a bulk capacitor ( $\geq 10\mu\text{F}$ ) may also be placed close to the VOUT pin. If using a bulk capacitor on VOUT, it is important to control the inrush current by choosing an appropriate soft-start time in order to minimize the droop on the input supply.

### Adjustable Slew Rate/Soft-Start

The SS pin allows the output ramp time of the switch to be controlled using an external capacitor ( $C_{SS}$ ). The capacitor voltage rises to approximately twice the value of VIN. Table 1 shows typical rise times (in  $\mu\text{s}$ ) associated with various timing capacitors at different VIN values.

Output Voltage Rise Time (in $\mu\text{s}$ )				
Measured at +25°C Using 0805 X7R 10% 25V Ceramic Capacitors				
VIN	1.8V	2.5V	3.3V	5.0V
VSS	3.5V	4.8V	6.4V	9.7V
CSS				
470pF	6.9	7.0	7.1	7.3
1nF	12.0	12.1	12.3	14.3
10nF	120	127	135	145
47nF	626	636	652	692
100nF	1305	1320	1340	1420
470nF	6320	6400	6660	7020
1000nF	13400	13040	13120	13800

Table 1. Timing Capacitors and Rise Times

Extra capacitance will allow further increase in rise time if desired. The timing capacitor should have a breakdown voltage of at least 25V to allow for a high voltage on this pin.

### Adjustable Discharge

When EN goes low, VOUT is discharged to ground through the discharge resistor ( $R_{DIS}$ ). The discharge/fall time on VOUT is largely controlled by  $R_{DIS}$  and by the output capacitor. The data in Table 2 shows typical fall times associated with various discharge resistors with  $C_L = 1\mu\text{F}$ , for different values of VIN.

1206 250mW 1% Discharge Resistor ( $\Omega$ )	Fall Time (in ms)			
	Measured at +25°C, with $C_L = 1\mu\text{F}$ , $R_L = \text{Open}$			
	1.8V	2.5V	3.3V	5V
100	0.25	0.26	0.26	0.27
470	1.07	1.09	1.12	1.18
1000	2.28	2.32	2.40	2.54
4700	10.42	10.65	10.90	11.50
10000	23.33	24.30	24.50	25.05

Table 2. Discharge Resistors and Output Voltage Fall Times

## Board Layout and Thermal Considerations

Due to the high current capacity of the load switch, PCB layout needs to ensure good thermal distribution during operation. The top and bottom of AP22800EV1, the evaluation board for the AP22800, can be seen below.

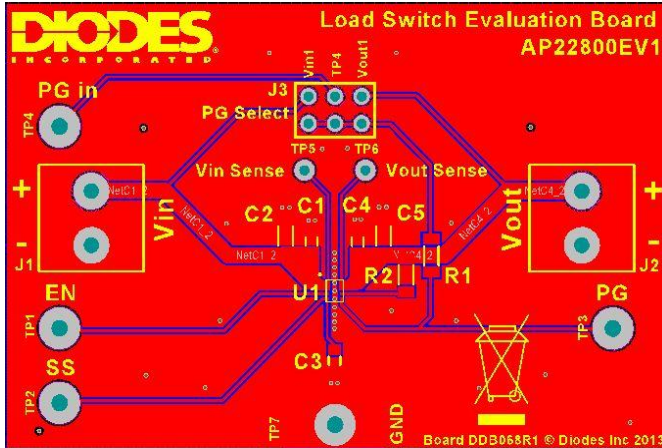

Figure 1. PCB Copper Layout & Silk Screen – Top



Figure 2. PCB Copper Layout & Silk Screen – Bottom

Thermal vias are used directly underneath the chip to help distribute the heat from the device. The ground plane on the underside of the board effectively acts as a large heatsink. The widths of the tracks carrying VIN and VOUT are kept wide. Vias are also distributed around the board to aid thermal conduction and to ensure a consistent potential, particularly around the ground connections of the capacitors. All capacitors used are located as close as possible to the AP22800 to minimize any parasitic effects.

The maximum junction temperature of the AP22800 is +125°C. To ensure that this is not exceeded, the following equation can be used to give an approximation of junction temperature. Temperature readings taken with a thermal camera can also give a good approximation of power dissipation with the use of this equation. The board layout has a major influence on the parameter  $\theta_{JA}$ .

$$T_J = T_A + (\theta_{JA} \times P_D)$$

- where,
- $T_J$  = Junction temperature (°C)
  - $T_A$  = Ambient temperature (°C)
  - $\theta_{JA}$  = Junction to ambient thermal impedance (°C/W)
  - $P_D$  = Power dissipation (voltage drop across device × output current) (W)

NEW PRODUCT

**Ordering Information**

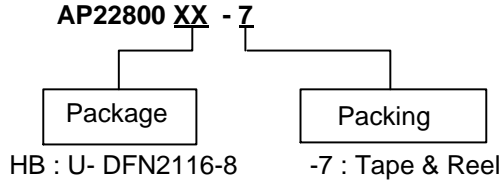

Part Number	Package Code	Packaging	7" Tape and Reel	
			Quantity	Part Number Suffix
AP22800HB-7	HB	U-DFN2116-8	3000/Tape & Reel	-7

**Marking Information**

U-DFN2116-8

(Top View)

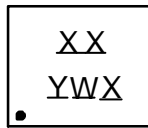

- XX : Identification Code
- Y : Year : 0~9
- W : Week : A~Z : 1~26 Week;  
a~z : 27~52 Week; z Represents  
52 and 53 Week
- Z : Internal Code

Part Number	Package	Identification Code
AP22800HB-7	U-DFN2116-8	WA

**Package Outline Dimensions** (All dimensions in mm.)

Please see AP02002 at <http://www.diodes.com/datasheets/ap02002.pdf> for the latest version.

(1) Package Type: U-DFN2116-8

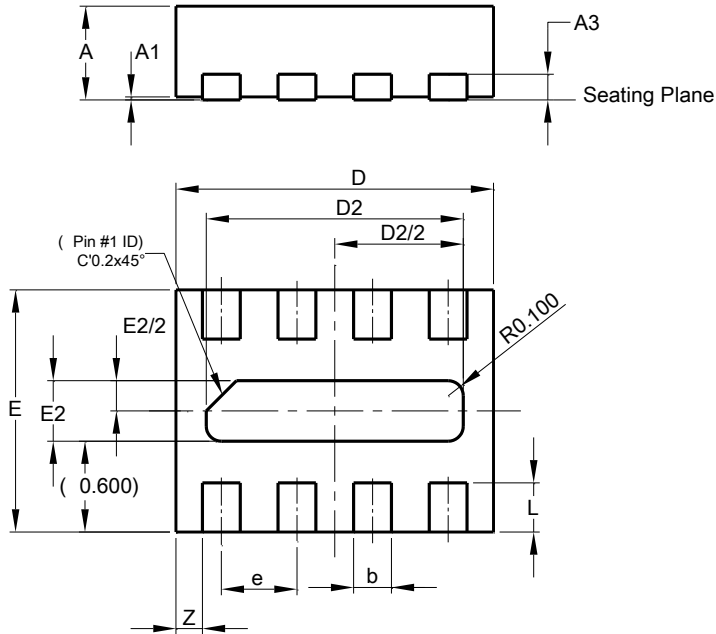

U-DFN2116-8			
Dim	Min	Max	Typ
A	0.545	0.605	0.575
A1	0.000	0.050	0.020
A3	-	-	0.130
b	0.200	0.300	0.250
D	2.050	2.175	2.100
D2	1.600	1.800	1.700
E	1.550	1.675	1.600
E2	0.300	0.500	0.400
e	-	-	0.500
L	0.275	0.375	0.325
Z	-	-	0.175
All Dimensions in mm			

**Suggested Pad Layout**

Please see AP02001 at <http://www.diodes.com/datasheets/ap02001.pdf> for the latest version.

(1) Package Type: U-DFN2116-8

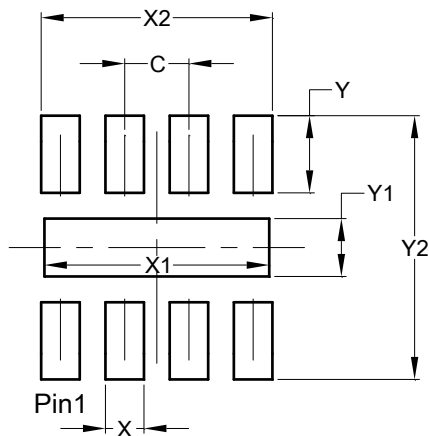

Dimensions	Value (in mm)
C	0.500
X	0.300
X1	1.750
X2	1.800
Y	0.600
Y1	0.450
Y2	2.050

**IMPORTANT NOTICE**

DIODES INCORPORATED MAKES NO WARRANTY OF ANY KIND, EXPRESS OR IMPLIED, WITH REGARDS TO THIS DOCUMENT, INCLUDING, BUT NOT LIMITED TO, THE IMPLIED WARRANTIES OF MERCHANTABILITY AND FITNESS FOR A PARTICULAR PURPOSE (AND THEIR EQUIVALENTS UNDER THE LAWS OF ANY JURISDICTION).

Diodes Incorporated and its subsidiaries reserve the right to make modifications, enhancements, improvements, corrections or other changes without further notice to this document and any product described herein. Diodes Incorporated does not assume any liability arising out of the application or use of this document or any product described herein; neither does Diodes Incorporated convey any license under its patent or trademark rights, nor the rights of others. Any Customer or user of this document or products described herein in such applications shall assume all risks of such use and will agree to hold Diodes Incorporated and all the companies whose products are represented on Diodes Incorporated website, harmless against all damages.

Diodes Incorporated does not warrant or accept any liability whatsoever in respect of any products purchased through unauthorized sales channel. Should Customers purchase or use Diodes Incorporated products for any unintended or unauthorized application, Customers shall indemnify and hold Diodes Incorporated and its representatives harmless against all claims, damages, expenses, and attorney fees arising out of, directly or indirectly, any claim of personal injury or death associated with such unintended or unauthorized application.

Products described herein may be covered by one or more United States, international or foreign patents pending. Product names and markings noted herein may also be covered by one or more United States, international or foreign trademarks.

This document is written in English but may be translated into multiple languages for reference. Only the English version of this document is the final and determinative format released by Diodes Incorporated.

**LIFE SUPPORT**

Diodes Incorporated products are specifically not authorized for use as critical components in life support devices or systems without the express written approval of the Chief Executive Officer of Diodes Incorporated. As used herein:

A. Life support devices or systems are devices or systems which:

1. are intended to implant into the body, or
2. support or sustain life and whose failure to perform when properly used in accordance with instructions for use provided in the labeling can be reasonably expected to result in significant injury to the user.

B. A critical component is any component in a life support device or system whose failure to perform can be reasonably expected to cause the failure of the life support device or to affect its safety or effectiveness.

Customers represent that they have all necessary expertise in the safety and regulatory ramifications of their life support devices or systems, and acknowledge and agree that they are solely responsible for all legal, regulatory and safety-related requirements concerning their products and any use of Diodes Incorporated products in such safety-critical, life support devices or systems, notwithstanding any devices- or systems-related information or support that may be provided by Diodes Incorporated. Further, Customers must fully indemnify Diodes Incorporated and its representatives against any damages arising out of the use of Diodes Incorporated products in such safety-critical, life support devices or systems.

Copyright © 2015, Diodes Incorporated

[www.diodes.com](http://www.diodes.com)

Компания «Океан Электроники» предлагает заключение долгосрочных отношений при поставках импортных электронных компонентов на взаимовыгодных условиях!

Наши преимущества:

- Поставка оригинальных импортных электронных компонентов напрямую с производств Америки, Европы и Азии, а так же с крупнейших складов мира;
- Широкая линейка поставок активных и пассивных импортных электронных компонентов (более 30 млн. наименований);
- Поставка сложных, дефицитных, либо снятых с производства позиций;
- Оперативные сроки поставки под заказ (от 5 рабочих дней);
- Экспресс доставка в любую точку России;
- Помощь Конструкторского Отдела и консультации квалифицированных инженеров;
- Техническая поддержка проекта, помощь в подборе аналогов, поставка прототипов;
- Поставка электронных компонентов под контролем ВП;
- Система менеджмента качества сертифицирована по Международному стандарту ISO 9001;
- При необходимости вся продукция военного и аэрокосмического назначения проходит испытания и сертификацию в лаборатории (по согласованию с заказчиком);
- Поставка специализированных компонентов военного и аэрокосмического уровня качества (Xilinx, Altera, Analog Devices, Intersil, Interpoint, Microsemi, Actel, Aeroflex, Peregrine, VPT, Syfer, Eurofarad, Texas Instruments, MS Kennedy, Miteq, Cobham, E2V, MA-COM, Hittite, Mini-Circuits, General Dynamics и др.);

Компания «Океан Электроники» является официальным дистрибьютором и эксклюзивным представителем в России одного из крупнейших производителей разъемов военного и аэрокосмического назначения «JONHON», а так же официальным дистрибьютором и эксклюзивным представителем в России производителя высокотехнологичных и надежных решений для передачи СВЧ сигналов «FORSTAR».



## JONHON

«JONHON» (основан в 1970 г.)

Разъемы специального, военного и аэрокосмического назначения:

(Применяются в военной, авиационной, аэрокосмической, морской, железнодорожной, горно- и нефтедобывающей отраслях промышленности)

«FORSTAR» (основан в 1998 г.)

ВЧ соединители, коаксиальные кабели, кабельные сборки и микроволновые компоненты:

(Применяются в телекоммуникациях гражданского и специального назначения, в средствах связи, РЛС, а так же военной, авиационной и аэрокосмической отраслях промышленности).



Телефон: 8 (812) 309-75-97 (многоканальный)

Факс: 8 (812) 320-03-32

Электронная почта: [ocean@oceanchips.ru](mailto:ocean@oceanchips.ru)

Web: <http://oceanchips.ru/>

Адрес: 198099, г. Санкт-Петербург, ул. Калинина, д. 2, корп. 4, лит. А