

TLT807B0EPV Demoboard

Z8F56520820

Preface

Scope and purpose

This application note provides information about the usage of the TLT807B0 Demoboard. The TLT807B0 Demoboard is used to demonstrate the ultra low quiescent current linear voltage regulator family TLT807B0 in a PG-TSDSO-14 package from Infineon Technologies AG. Please also refer to the corresponding Data Sheet [DS](#).

Intended audience

This document is intended for engineers who develop applications.

Table of contents

	Preface	1
	Table of contents	1
1	Introduction	2
1.1	General description	2
1.2	TLT807B0: Feature set	3
1.3	Block diagram	3
2	Demoboard	4
2.1	Operating conditions	5
2.2	Demoboard configuration	5
2.2.1	Enable function	5
2.2.2	Adjustable output voltage	5
3	Schematic and layout	7
3.1	Schematic	7
3.2	Layout	7
4	Bill of material	9
5	Restrictions	11
6	References	12
7	Revision history	13
	Trademarks	14

Introduction

1 Introduction

This document describes the evaluation board for the TLT807B0 and its functionality. It includes a brief summary of the used passive components, as well as a short explanation for the correct usage of the board. The description of the TLT807B0 is not subject of this application note. Specifications and parameters for the device shall be taken from the corresponding data sheet.

1.1 General description

The TLT807B0 is a standby linear voltage regulator which is designed for 24 V systems and the demanding environment of truck applications. It is optimized for low drop and current consumption in off mode. Additionally it is capable to withstand high voltage transients.

Introduction

1.2 TLT807B0: Feature set

To meet the automotive standards the TLT807B0 comes with a feature set, that includes:

- Output voltage accuracy at +/-2%
- Enable: reduces the current consumption to a minimum while the application is not used
- Adjustable output voltage: 1.2 V to 20 V
- Protection functions:
 - Output current limitation
 - Reverse polarity protection
 - Overtemperature shutdown
- Protected against high input transients up to 58 V for less than 400 ms

1.3 Block diagram

Following the block diagram of TLT807B0 is illustrated. It shows the device's basic feature set and their interaction. The parameters for each block shall be taken from the corresponding data sheet.

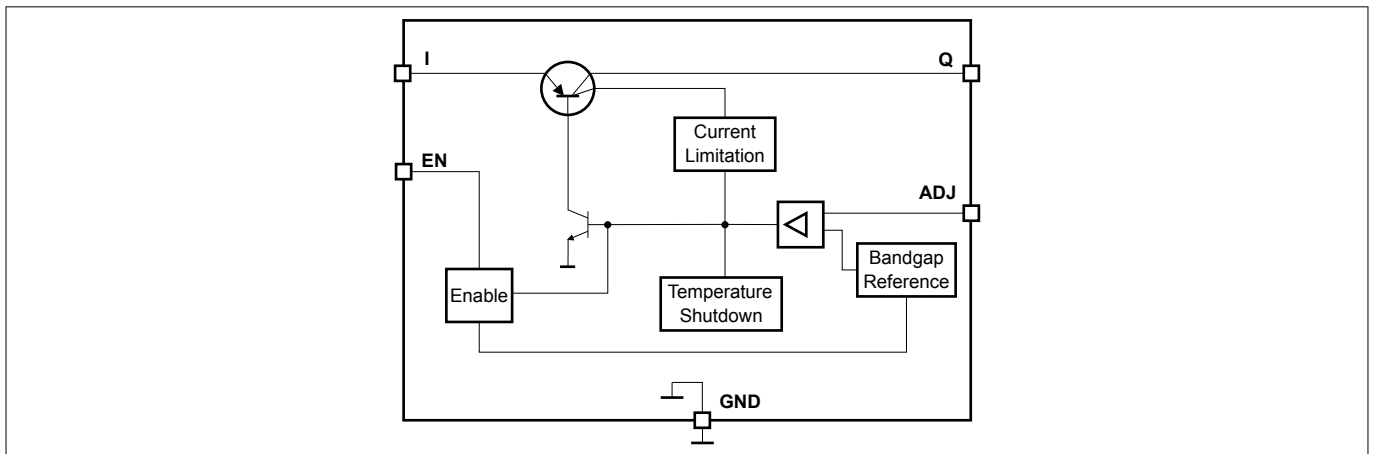

Figure 1 TLT807B0 block diagram

Demoboard

2 Demoboard

The TLT807B0 Demoboard is available for the PG-TSDSO-14 package. Basic functions of the device can be evaluated with it, as well as identifying the proper configuration. Apart from that it may serve as help to observe the device's behavior outside of the application and under isolated conditions of stress.

The figure [Figure 2](#) shows the TLT807B0 Demoboard.

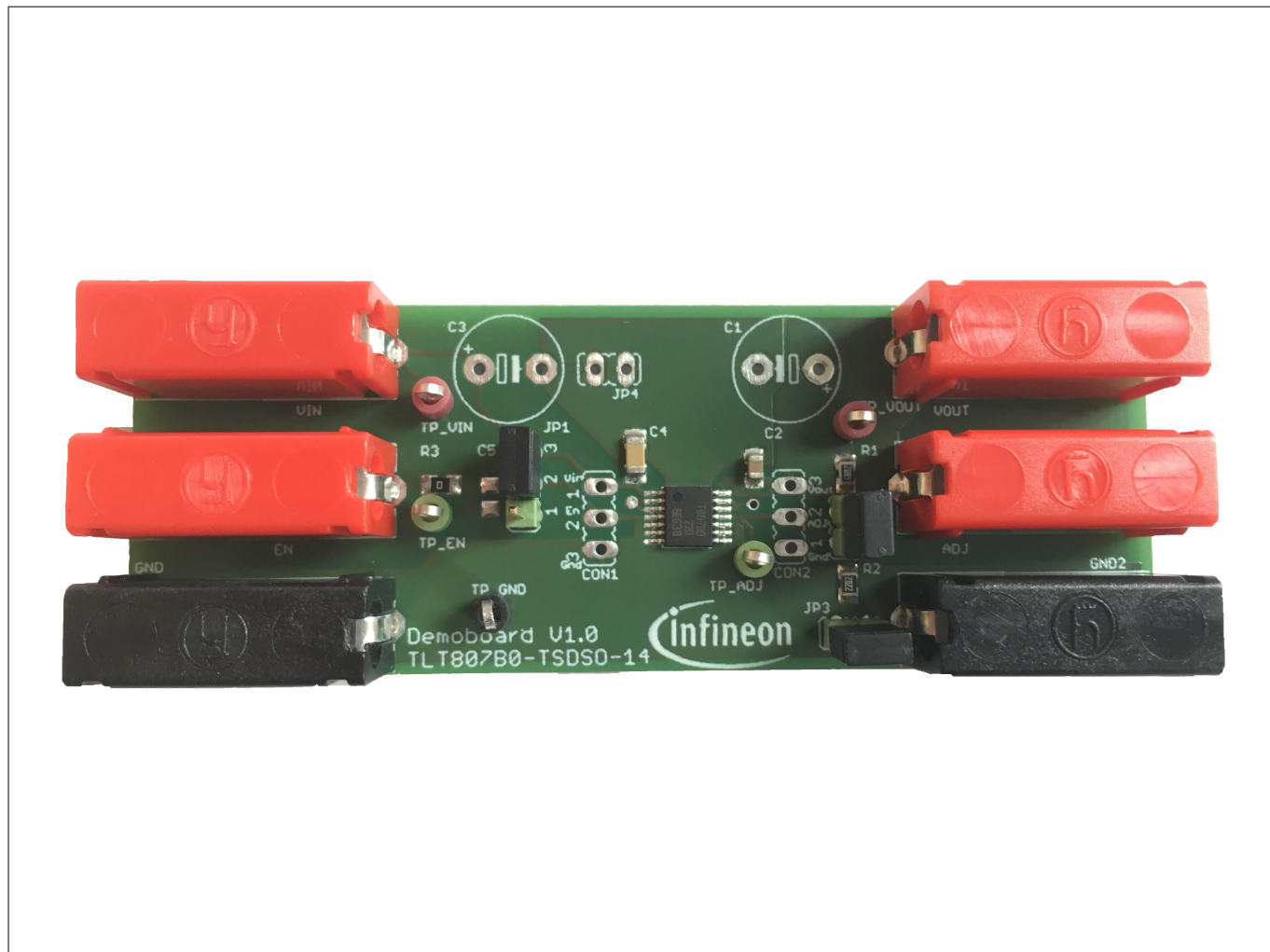

Figure 2 TLT807B0 Demoboard

Demoboard

2.1 Operating conditions

To avoid electrical damage of the Demoboard, the operating range defined in [Table 1](#) must be followed.

Table 1 Operating range¹⁾

Parameter	Symbol	Limit values		Unit	Note
		Min.	Max.		
Board supply ²⁾	V _{IN}	0	45	V	Power supply
Regulator output	V _{OUT}	0	36	V	Regulated output voltage
Enable input signal	EN	0	45 ³⁾	V	Enable signal to switch on the regulator

2.2 Demoboard configuration

The TLT807B0 Demoboard enables the operator to use and test the basic function set of the TLT807B0. This includes following features:

- Connecting the Enable input signal to the supply voltage V_{IN} via jumper JP1
- Placeholder for additional input capacitor (C3)
- Placeholder for additional output capacitor (C1)
- Configure the output voltage via the resistor divider (R₁, R₂)
- Disable the resistor divider R₁,R₂ via jumper JP2 and JP3
- Connecting a external resistor divider via the banana jack ADJ

For further information regarding the configuration refer to the chapter [Schematic](#) and its component description.

2.2.1 Enable function

The jumper JP1 can be used to connect the EN signal to the supply voltage V_{IN} or pull it to GND. Furthermore an external enable signal can be applied by using the banana jack EN.

Table 2 Jumper JP1 setting for enable function

JP1	Enable function
Pin 3 to pin 2	EN is connected to the supply voltage V _{IN} ; the regulator is enabled while it is supplied
Pin 2 to pin 1	EN is pulled to GND
Open	EN is floating, external enable signal can be applied via the banana jack EN

2.2.2 Adjustable output voltage

The TLT807B0 is an adjustable standby linear voltage regulator. Therefore the TLT807B0EPV Demoboard provides the option to configure the external voltage divider in two ways:

1. Changing the ratio of the voltage divider R₁ and R₂
2. Apply a feedback off board via the banana jack ADJ⁴⁾

¹ The Demoboard operates at an ambient temperature of 25°C

² Functional input voltage range: 2.75 V to 42 V

³ Absolute maximum rating

⁴ Make sure that the voltage divider on board is disconnected by pulling jumper JP2 and JP3

Demoboard

When dimensioning the ratio of the voltage divider, equations

$$V_Q = \left(\frac{R_1}{R_2} + 1 \right) V_{\text{ref}}$$

Equation 1

$$R_1 + R_2 \leq 250 \text{ k}\Omega$$

Equation 2

Schematic and layout

3 Schematic and layout

Following the schematic and the layout of the board are illustrated. For a better understanding and tracing of the connections these figures can be used. In case of further questions please address to the IFAG ATV PSN AE support box.

3.1 Schematic

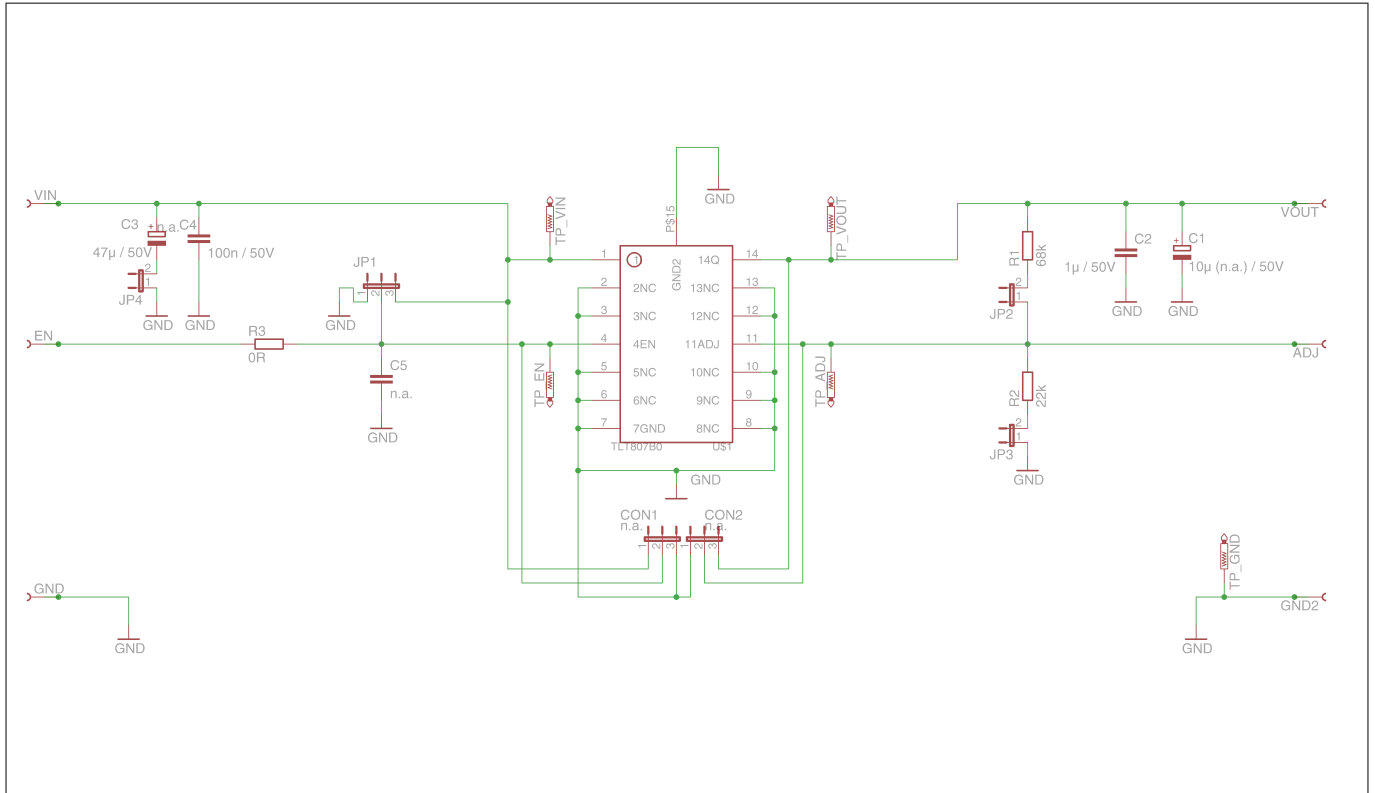

Figure 3 Schematic of TLT807B0 Demoboard

3.2 Layout

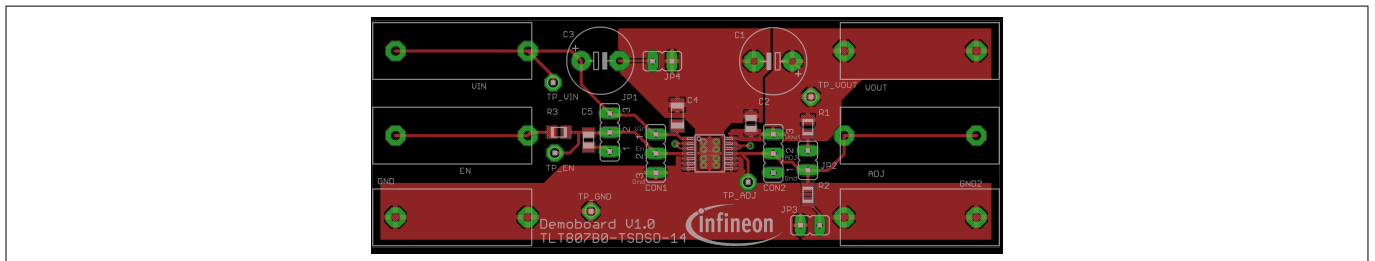

Figure 4 Top layer of TLT807B0 Demoboard

Schematic and layout

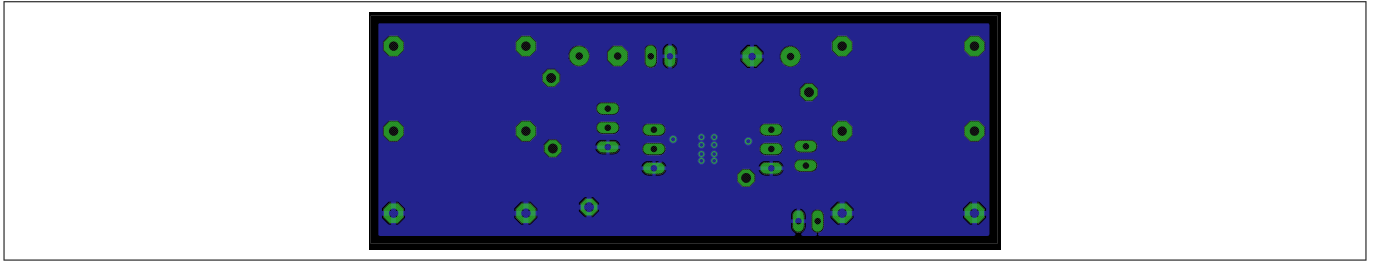

Figure 5 Bottom layer of TLT807B0 Demoboard

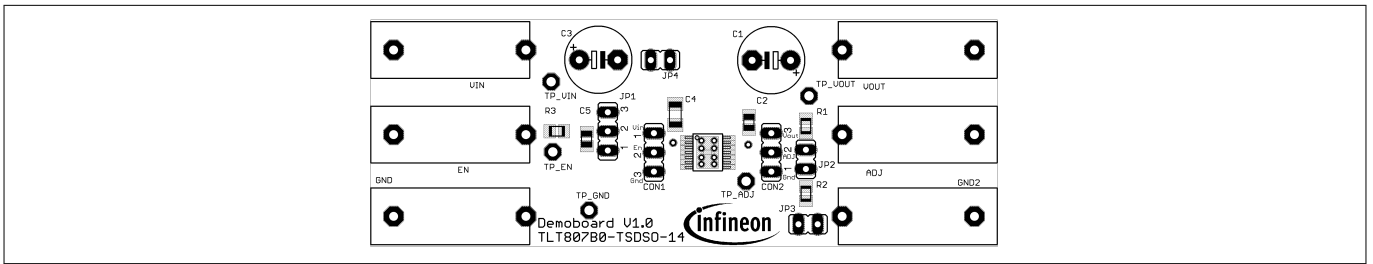

Figure 6 Top layer components of TLT807B0 Demoboard

Bill of material

4 Bill of material

Table 3 Bill of materials

Part	Value	Device	Package	Description
ADJ		BABU4MM	BANANENBUCHSE4 MM	
C1	10 μ (n.a.) / 50V	CPOL-EUE5-8.5	E5-8,5	POLARIZED CAPACITOR, European symbol
C2	1 μ / 50V	C-EUC0805	C0805	CAPACITOR, European symbol
C3	47 μ / 50V	CPOL-EUE5-8.5	E5-8,5	POLARIZED CAPACITOR, European symbol
C4	100n / 50V	C-EUC1206	C1206	CAPACITOR, European symbol
C5	n.a.	C-EUC0805	C0805	CAPACITOR, European symbol
CON1	n.a.	JP2E	JP2	JUMPER
CON2	n.a.	JP2E	JP2	JUMPER
EN		BABU4MM	BANANENBUCHSE4 MM	
GND		BABU4MM	BANANENBUCHSE4 MM	
GND2		BABU4MM	BANANENBUCHSE4 MM	
JP1		JP2E	JP2	JUMPER
JP2		JP1E	JP1	JUMPER
JP3		JP1E	JP1	JUMPER
JP4		JP1E	JP1	JUMPER
R1	68k	R-EU_M0805	M0805	RESISTOR, European symbol
R2	22k	R-EU_M0805	M0805	RESISTOR, European symbol
R3	0R	R-EU_M0805	M0805	RESISTOR, European symbol
TP_ADJ		PTR1PAD1-13	P1-13	TEST PIN
TP_EN		PTR1PAD1-13	P1-13	TEST PIN
TP_GND		PTR1PAD1-13	P1-13	TEST PIN
TP_VIN		PTR1PAD1-13	P1-13	TEST PIN
TP_VOUT		PTR1PAD1-13	P1-13	TEST PIN

Bill of material

Table 3 Bill of materials (continued)

Part	Value	Device	Package	Description
U\$1	TLT807B0	TLT807B0	PG-TSDSO-14	TruckVreg
VIN		BABU4MM	BANANENBUCHSE4 MM	
VOUT		BABU4MM	BANANENBUCHSE4 MM	

Restrictions

5 Restrictions

The demoboard for the TLT807B0 is only intended to be used for evaluation and test purposes. Basic safety features and functions can be tested with it. It must not be used for any field production.

For further information please refer to www.infineon.com.

References

6 References

Table 4

Number	Bibliography
[1]	What The Designer Should Know – Introduction to Automotive Linear Voltage Regulators. Infineon Technologies AG
[2]	TLT807B0EPV Data Sheet, Infineon Technologies AG: https://www.infineon.com/dgdl/Infineon-TLT807B0EPV-DS-v01_00-EN.pdf?fileId=5546d4625bd71aa0015c10aadbe33e93

Revision history

7 Revision history

Revision	Date	Changes
1.0	2017-06-28	Initial version

Trademarks

All referenced product or service names and trademarks are the property of their respective owners.

Edition 2017-06-28

Published by

Infineon Technologies AG

81726 Munich, Germany

© 2017 Infineon Technologies AG

All Rights Reserved.

Do you have a question about any aspect of this document?

Email: erratum@infineon.com

Document reference

IFX-Z8F56520820

IMPORTANT NOTICE

The information contained in this application note is given as a hint for the implementation of the product only and shall in no event be regarded as a description or warranty of a certain functionality, condition or quality of the product. Before implementation of the product, the recipient of this application note must verify any function and other technical information given herein in the real application. Infineon Technologies hereby disclaims any and all warranties and liabilities of any kind (including without limitation warranties of non-infringement of intellectual property rights of any third party) with respect to any and all information given in this application note.

The data contained in this document is exclusively intended for technically trained staff. It is the responsibility of customer's technical departments to evaluate the suitability of the product for the intended application and the completeness of the product information given in this document with respect to such application.

WARNINGS

Due to technical requirements products may contain dangerous substances. For information on the types in question please contact your nearest Infineon Technologies office.

Except as otherwise explicitly approved by Infineon Technologies in a written document signed by authorized representatives of Infineon Technologies, Infineon Technologies' products may not be used in any applications where a failure of the product or any consequences of the use thereof can reasonably be expected to result in personal injury

Компания «Океан Электроники» предлагает заключение долгосрочных отношений при поставках импортных электронных компонентов на взаимовыгодных условиях!

Наши преимущества:

- Поставка оригинальных импортных электронных компонентов напрямую с производств Америки, Европы и Азии, а так же с крупнейших складов мира;
- Широкая линейка поставок активных и пассивных импортных электронных компонентов (более 30 млн. наименований);
- Поставка сложных, дефицитных, либо снятых с производства позиций;
- Оперативные сроки поставки под заказ (от 5 рабочих дней);
- Экспресс доставка в любую точку России;
- Помощь Конструкторского Отдела и консультации квалифицированных инженеров;
- Техническая поддержка проекта, помощь в подборе аналогов, поставка прототипов;
- Поставка электронных компонентов под контролем ВП;
- Система менеджмента качества сертифицирована по Международному стандарту ISO 9001;
- При необходимости вся продукция военного и аэрокосмического назначения проходит испытания и сертификацию в лаборатории (по согласованию с заказчиком);
- Поставка специализированных компонентов военного и аэрокосмического уровня качества (Xilinx, Altera, Analog Devices, Intersil, Interpoint, Microsemi, Actel, Aeroflex, Peregrine, VPT, Syfer, Eurofarad, Texas Instruments, MS Kennedy, Miteq, Cobham, E2V, MA-COM, Hittite, Mini-Circuits, General Dynamics и др.);

Компания «Океан Электроники» является официальным дистрибьютором и эксклюзивным представителем в России одного из крупнейших производителей разъемов военного и аэрокосмического назначения «JONHON», а так же официальным дистрибьютором и эксклюзивным представителем в России производителя высокотехнологичных и надежных решений для передачи СВЧ сигналов «FORSTAR».



JONHON

«JONHON» (основан в 1970 г.)

Разъемы специального, военного и аэрокосмического назначения:

(Применяются в военной, авиационной, аэрокосмической, морской, железнодорожной, горно- и нефтедобывающей отраслях промышленности)

«FORSTAR» (основан в 1998 г.)

ВЧ соединители, коаксиальные кабели, кабельные сборки и микроволновые компоненты:

(Применяются в телекоммуникациях гражданского и специального назначения, в средствах связи, РЛС, а так же военной, авиационной и аэрокосмической отраслях промышленности).



Телефон: 8 (812) 309-75-97 (многоканальный)

Факс: 8 (812) 320-03-32

Электронная почта: ocean@oceanchips.ru

Web: <http://oceanchips.ru/>

Адрес: 198099, г. Санкт-Петербург, ул. Калинина, д. 2, корп. 4, лит. А