

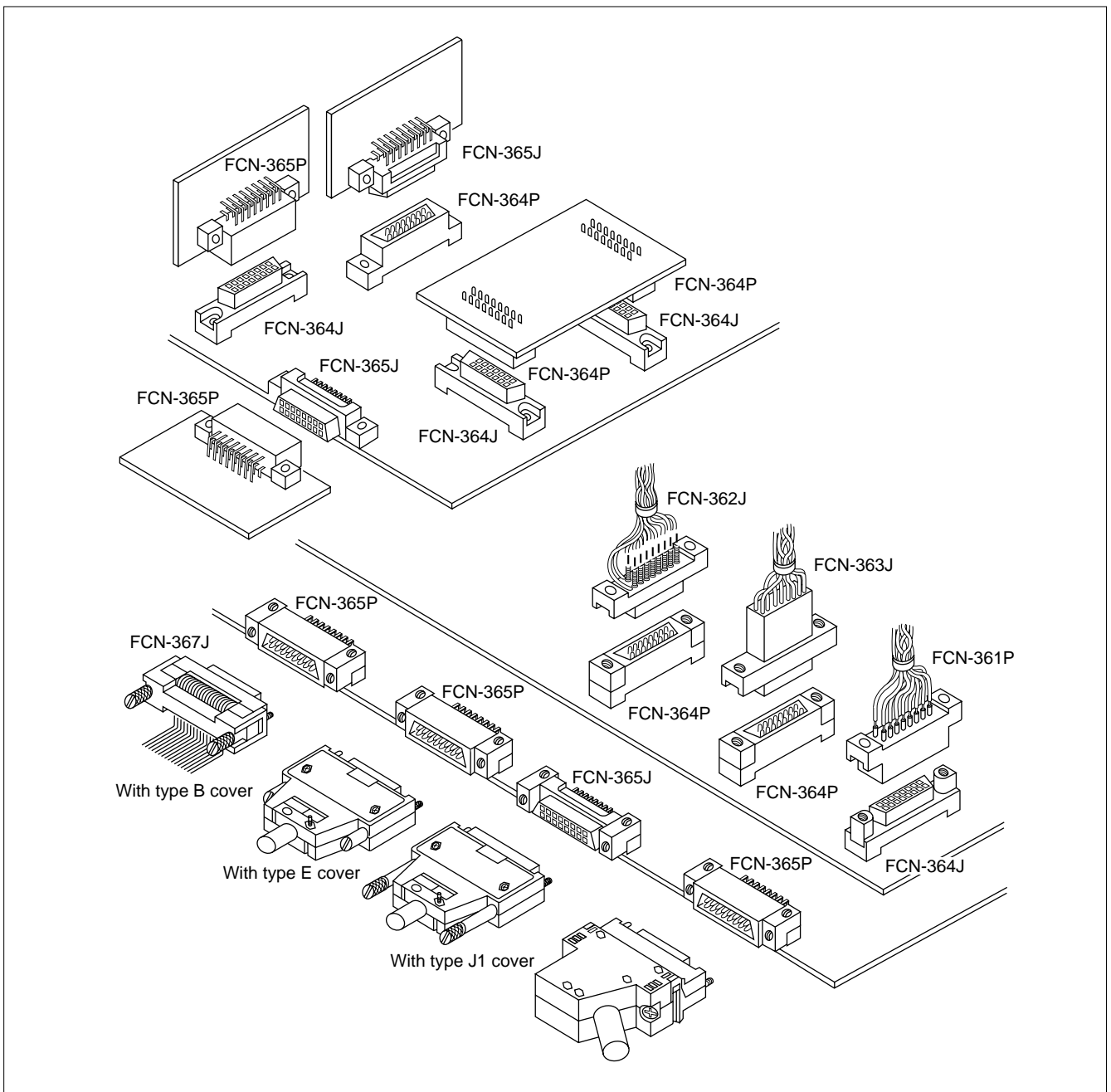



THE POSSIBILITIES ARE INFINITE

RECTANGULAR CONNECTORS

FCN360 Series



Terms in Selection Table (Example)

Model		700 series		
Appearance				
Structure	Contact pitch	2.54 × 2.54		
	Number of contacts	10, 14, 16, 20, 26, 30, 34, 40, 50, 60		
	Pin type	Solder eyelet (tail shape)	—	
		Wire-wrapping (post cross section)	P	□ 0.64
		J	—	
		Crimping (applicable AWG No.)	—	
		Straight, throughhole (PC board hole dimensions)	φ 0.8, 2.54 × 2.54	
		Right-angle, throughhole (PC board hole dimensions)	P	φ 0.8, 2.54 × 2.54
		J	—	
	IDC (applicable AWG No.)	P	#28, Flat cable	
J	#28, Flat cable			
Plating	Gold	○		
	Silver	—		
	Tin	○		
Specification	Operating temperature range	-55°C to +105°C		
	Current rating	DC 1 A		
	Voltage rating	AC 250 V		
	Contact resistance	20 mΩ max. (DC 6 V, 0.1 A)		
	Insulation resistance (DC 500 V)	1,000MΩ min.		
	Dielectric withstanding voltage (for 1 minute)	AC 500 V		
	Insulation material cleaning with Chlorothene	Polyester cleaning possible		
	Part number (example)	FCN-705P050-AU/M FCN-707J050-AU/B		
Remarks	EMI protection cover provided			

- Contact pitch**
 Denotes a pitch between adjacent contacts or pitch between rows.
 2.54 mm (0.100 in.) (pitch between adjacent contacts) x 2.54 mm (0.100 in.) (pitch between rows)
- Number of contacts**
 Denotes the numbers of contacts of available connectors.
- Connection type**
 Denotes the connection type of the cable or PC board connection section.
- Plating**
 Denotes the contact plating specification.
- Specifications**
 - Operating temperature range**
 The connector can be used within the specified temperature range.
 - Current rating**
 Maximum current that can flow through one connector pin
 - Voltage rating**
 Maximum voltage that can be applied to a connector
 - Contact resistance**
 Resistance observed at the contact part when 0.3 A (or 0.1 A) flows at 6 VDC with the connectors mated
 - Insulation resistance**
 Resistance to the leakage current flowing through the insulator (inside or surface of the insulator) when 500 VDC is applied across adjacent pins of a connector
 - Dielectric withstanding voltage**
 Applying the indicated voltage across adjacent pins of a connector for one minute does not cause any abnormality (damage or cracks in insulator).
 - Insulating material, cleaning with chlorothene**
 Denotes the insulating material used, and indicates whether the insulating material can be cleaned with chlorothene.
- Part number**
 Some part numbers are indicated as examples.

Rectangular Connectors

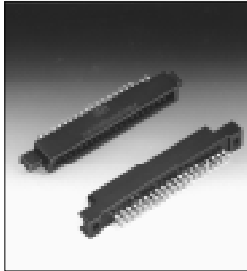
Model	360 series		
Appearance			
Structure	Contact pitch	2.54 × 2.54	
	Number of contacts	8, 16, 24, 32, 40, 48, 56, 64	
	Solder eyelet (tail shape)	P	1.8 × 0.7
		J	1.8 × 0.7
	Wire-wrapping (post cross section)	Diagonal 0.71 mm (0.028 in.)	
	Crimping (applicable AWG No.)	P	—
		J	AWG #22 to #28
	Straight, through hole (PC board hole dimensions)	P	φ1, 2.54 × 2.54
		J	φ1, 2.54 × 2.54
	Right-angle, through hole (PC board hole dimensions)	P	φ1, 2.54 × 2.54
		J	φ1, 2.54 × 2.54
	IDC (applicable AWG No.)	P	—
		J	#28, Flat cable
	Plating	Gold	○
Silver		○	
Tin		—	
Specification	Operating temperature range	-55°C to +85°C	
	Current rating	DC 3 A (IDC type: 1A)	
	Voltage rating	AC 250 V	
	Contact resistance	15 mΩ max. (DC 6 V, 0.3 A)	
	Insulation resistance (DC 500 V)	1,000 MΩ min.	
	Dielectric withstanding voltage (for 1 minute)	AC 500 V	
	Insulating material	Polyester PC (363J)	
Part number (example)	FCN-361P024-AU		
Remarks	Cable cover provided		

NOTES

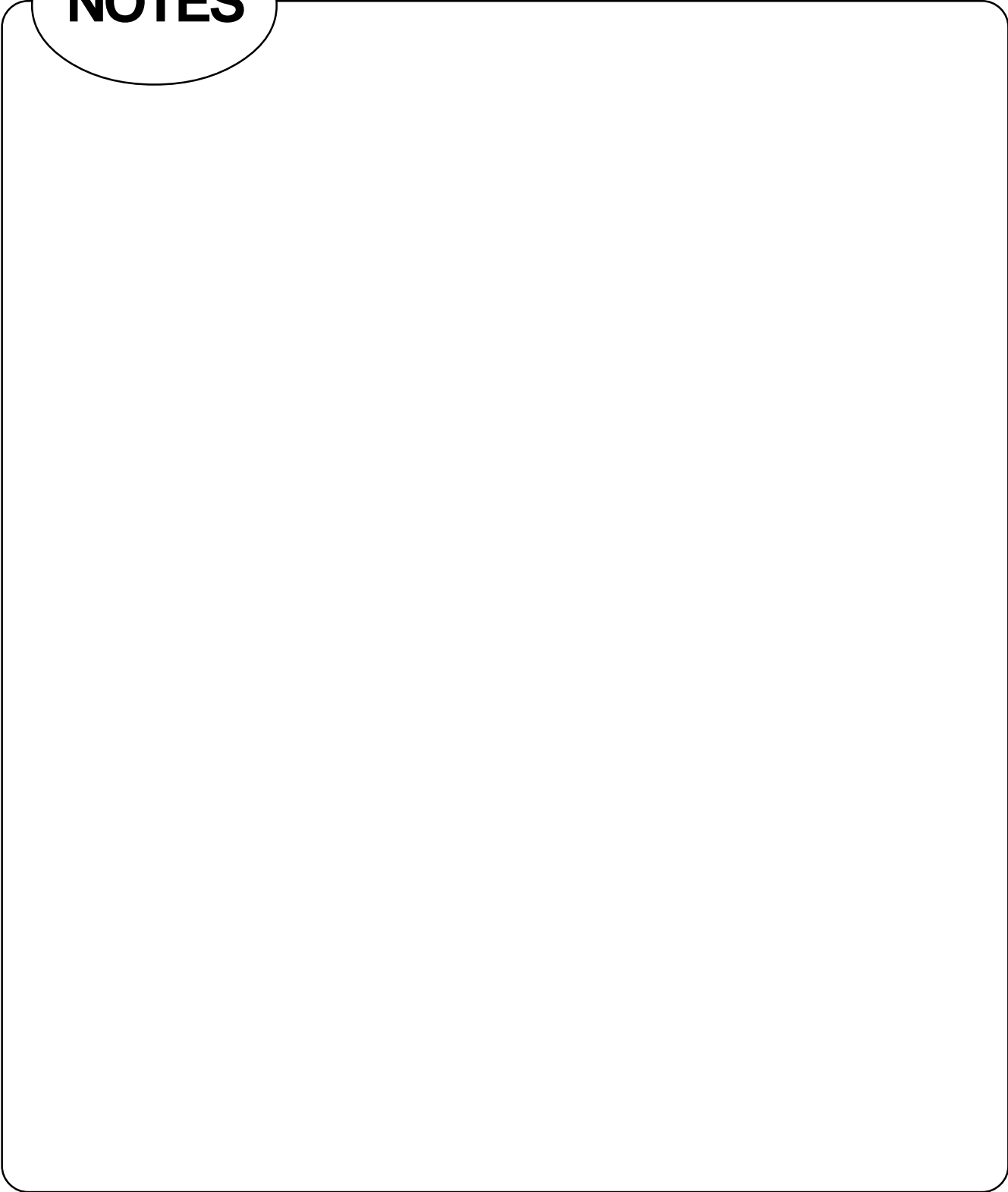

RECTANGULAR CONNECTORS

FCN-360 SERIES

■ FEATURES

- Many applications
Various connectors are available for connection by means of soldering, wire wrapping, crimping, PC board mounting, and insulation displacement connection (IDC). The user can choose a plug and jack combination that best meet each application.
- Small size for high-density mounting
The connectors are small with a contact and terminal pitch of 2.54 mm (0.100 in.) between pins and between rows and are thus well suited for high-density mounting.
- Sturdy shell guide
Sturdy shell guides are used to prevent mismatching and to protect the pins.
- Excellent cost performance
Streamlined design and automated manufacturing, including use of partial solder plating, provide excellent cost performance.



■ SPECIFICATIONS

Item	Specification	
Operating temperature range	-55°C to +85°C	
Current Rating	DC 3 A (IDC type: 1 A)	
Voltage Rating	AC 250 V	
Contact resistance	15 mΩ max. (DC 6 V, 0.3 A)	
Insulation resistance	1000 MΩ min. (DC 500 V)	
Dielectric withstanding voltage	AC 500 V for 1 minute	
Insertion force	2.5 kg max. (8 contacts), 20 kg max. (64 contacts)	
Withdrawal force	0.3 kg min. (8 contacts), 2.3 kg min. (64 contacts)	
Applicable wire	Soldering	φ0.60 mm (0.024 in.) max, AWG #23 or less
	Wire-wrapping	φ0.32 mm (0.013 in.) to φ0.26 mm (0.010 in.), AWG #28 to #30
	Crimping	Standard contacts φ0.51 mm (0.020 in.) to φ0.32 mm (0.013 in.), AWG #24 to #28, insulator φ1.2 mm (0.047 in.) max. Contacts for thick wires φ0.64 mm (0.025 in.) to φ0.32 mm (0.013 in.), AWG #22 to #28, insulator φ1.7 (0.067 in.) max.
	IDC	Flat cable 1.27 mm (0.050 in.) pitch, AWG #28 (stranded wire), AWG #30 (solid wire)
Applicable PC board	1.6 mm (0.063 in.) standard thick	

■ MATERIALS

Item	Material
Insulator	Polyester (363J: PC94V-2)
Conductor	Copper alloy
Plating	Gold plating, silver plating

■ PART NUMBER

FCN-36 7 J 048-AU / H



FCN-360 Series

APPLICATION EXAMPLE



SOLDERING TYPE (PLUG)

■ DIMENSIONS

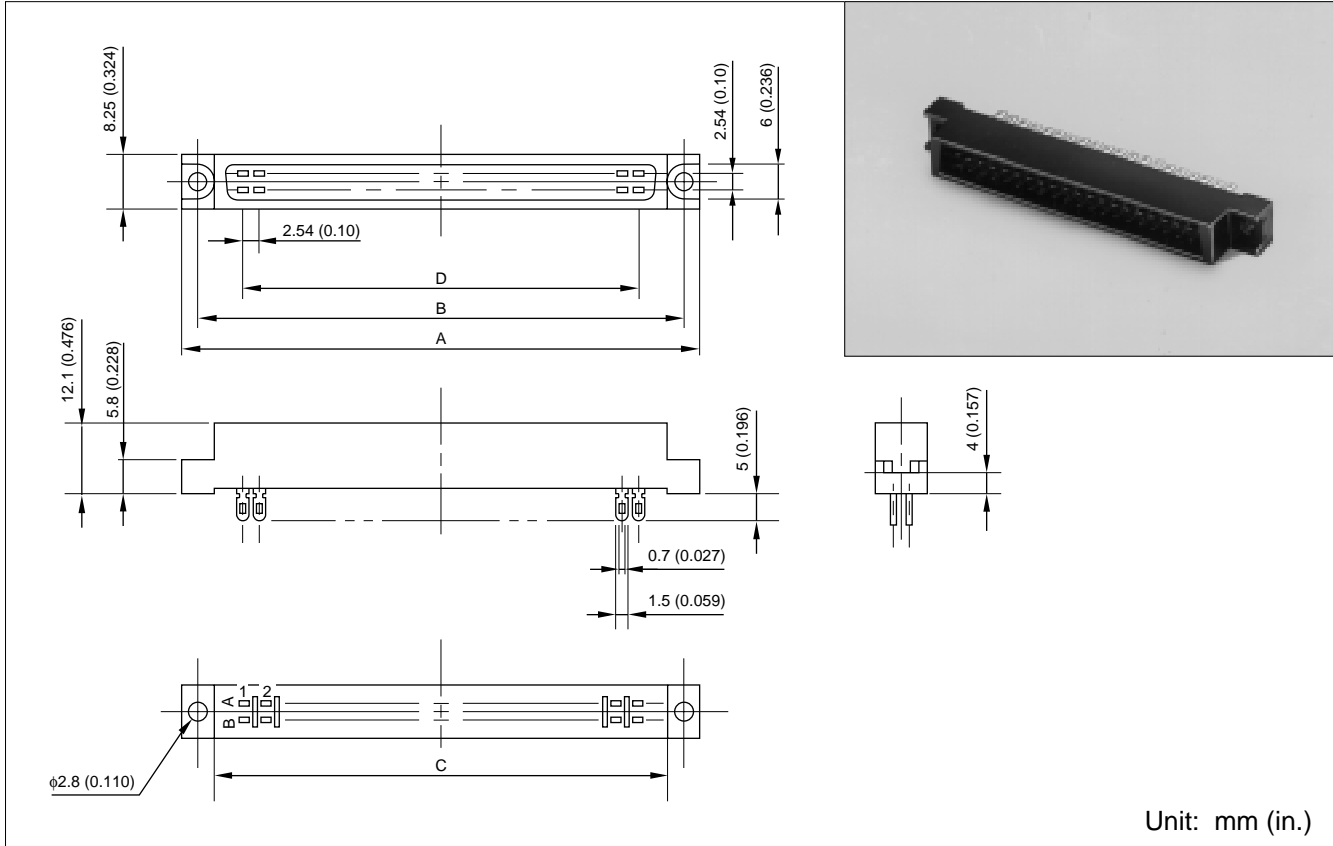

■ MOUNTING HOLE LAYOUT



■ PART NUMBERS AND DIMENSIONS

Number of contacts	Part number	Dimensions: mm (in.)			
		A	B	C	D
8	FCN-361P008-AU	28.84 (1.135)	23.34 (0.918)	17.84 (0.702)	7.62 (0.3)
16	FCN-361P016-AU	39.0 (1.535)	33.5 (1.318)	28.0 (1.102)	17.78 (0.7)
24	FCN-361P024-AU	49.16 (1.935)	43.66 (1.718)	38.16 (1.502)	27.94 (1.1)
32	FCN-361P032-AU	59.32 (2.335)	53.82 (2.118)	48.32 (1.902)	38.1 (1.5)
40	FCN-361P040-AU	69.48 (2.735)	63.98 (2.518)	58.48 (2.302)	48.26 (1.9)
48	FCN-361P048-AU	79.64 (3.135)	74.14 (2.918)	68.64 (2.702)	58.42 (2.3)
56	FCN-361P056-AU	89.8 (3.535)	84.3 (3.318)	78.8 (3.102)	68.58 (2.7)
64	FCN-361P064-AU	99.96 (3.935)	94.46 (3.718)	88.96 (3.502)	78.74 (3.1)

FCN-360 Series

SOLDERING TYPE (JACK)

■ DIMENSIONS

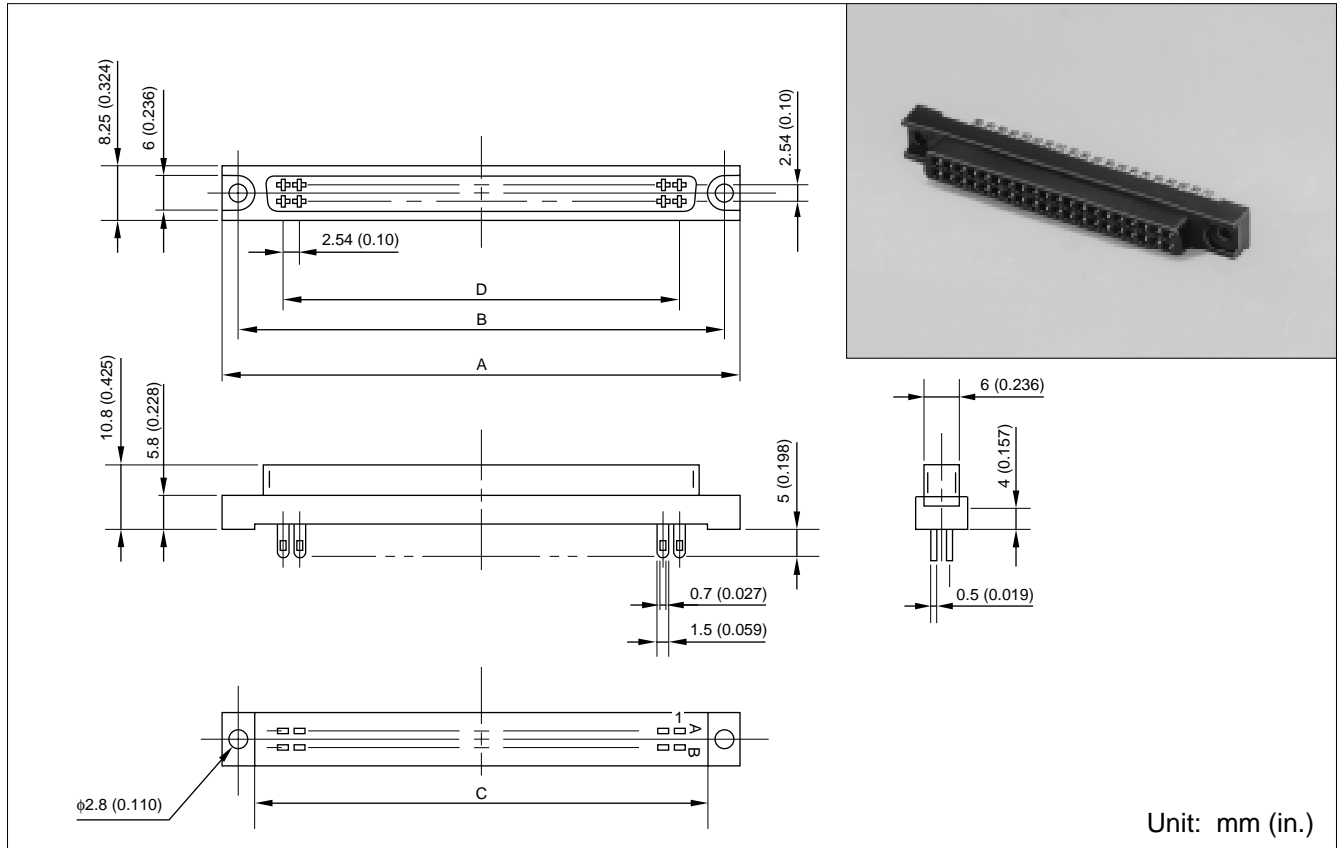

■ BOARD MOUNTING HOLE LAYOUT

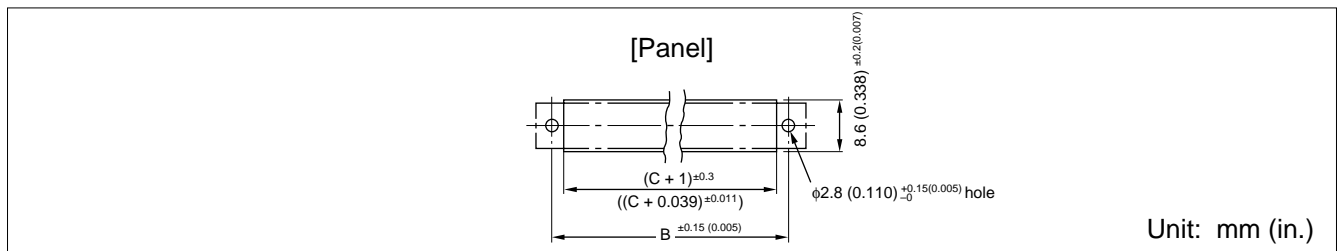

■ PART NUMBERS AND DIMENSIONS

Number of contacts	Part number	Dimensions: mm (in.)			
		A	B	C	D
8	FCN-361J008-AU	28.84 (1.135)	23.34 (0.918)	17.84 (0.702)	7.62 (0.3)
16	FCN-361J016-AU	39.0 (1.535)	33.5 (1.318)	28.0 (1.102)	17.78 (0.7)
24	FCN-361J024-AU	49.16 (1.935)	43.66 (1.718)	38.16 (1.502)	27.94 (1.1)
32	FCN-361J032-AU	59.32 (2.335)	53.82 (2.118)	48.32 (1.902)	38.1 (1.5)
40	FCN-361J040-AU	69.48 (2.735)	63.98 (2.518)	58.48 (2.302)	48.26 (1.9)
48	FCN-361J048-AU	79.64 (3.135)	74.14 (2.918)	68.64 (2.702)	58.42 (2.3)
56	FCN-361J056-AU	89.8 (3.535)	84.3 (3.318)	78.8 (3.102)	68.58 (2.7)
64	FCN-361J064-AU	99.96 (3.935)	94.46 (3.718)	88.96 (3.502)	78.74 (3.1)

WIRE-WRAP TYPE (PLUG)

■ DIMENSIONS



■ MOUNTING HOLE LAYOUT



■ PART NUMBERS AND DIMENSIONS

Number of contacts	Part number	Dimensions: mm (in.)			
		A	B	C	D
8	FCN-362P008-AU	28.84 (1.135)	23.34 (0.918)	17.84 (0.702)	7.62 (0.3)
16	FCN-362P016-AU	39.0 (1.535)	33.5 (1.318)	28.0 (1.102)	17.78 (0.7)
24	FCN-362P024-AU	49.16 (1.935)	43.66 (1.718)	38.16 (1.502)	27.94 (1.1)
32	FCN-362P032-AU	59.32 (2.335)	53.82 (2.118)	48.32 (1.902)	38.1 (1.5)
40	FCN-362P040-AU	69.48 (2.735)	63.98 (2.518)	58.48 (2.302)	48.26 (1.9)
48	FCN-362P048-AU	79.64 (3.135)	74.14 (2.918)	68.64 (2.702)	58.42 (2.3)
56	FCN-362P056-AU	89.8 (3.535)	84.3 (3.318)	78.8 (3.102)	68.58 (2.7)
64	FCN-362P064-AU	99.96 (3.935)	94.46 (3.718)	88.96 (3.502)	78.74 (3.1)

FCN-360 Series

WIRE-WRAP TYPE (JACK)

■ DIMENSIONS

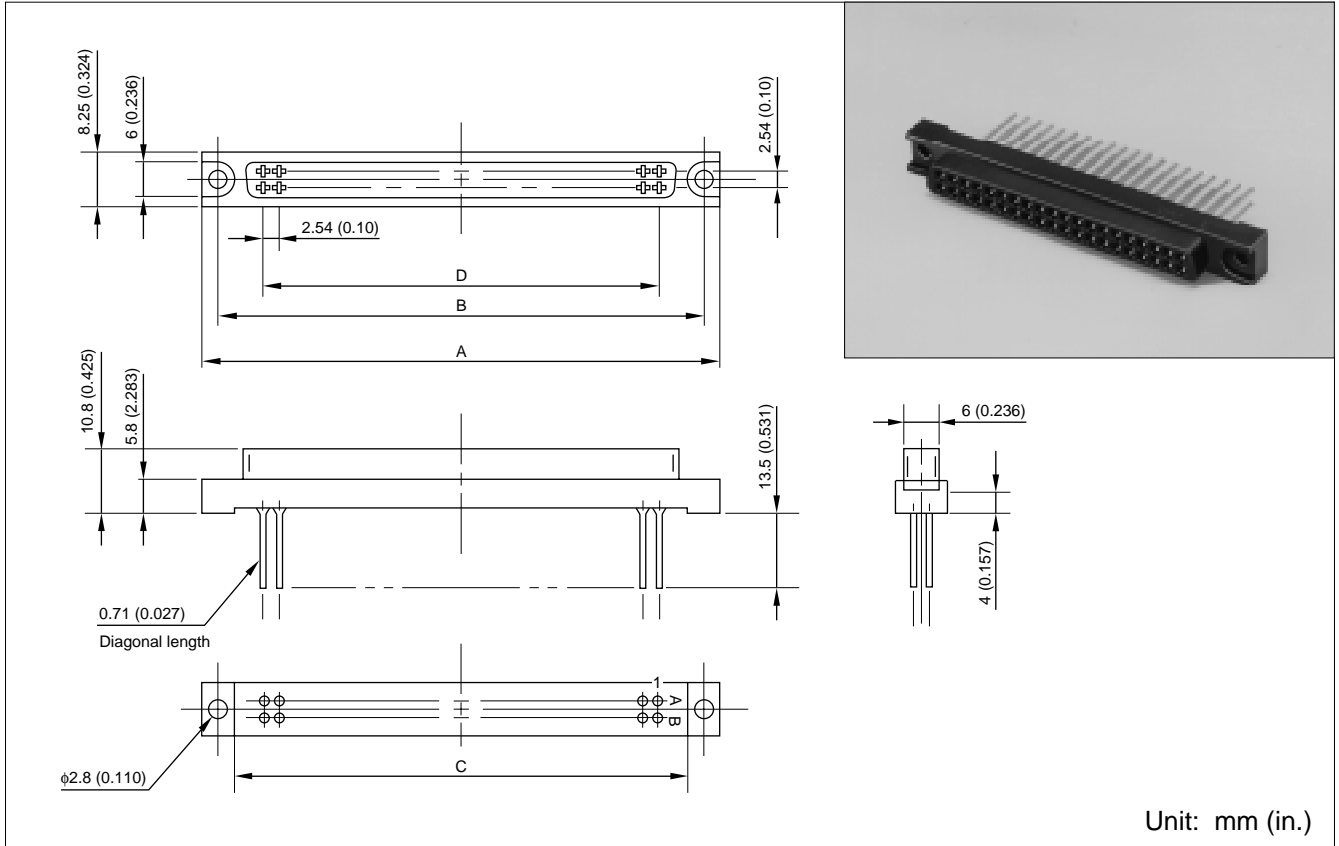

■ MOUNTING HOLE LAYOUT

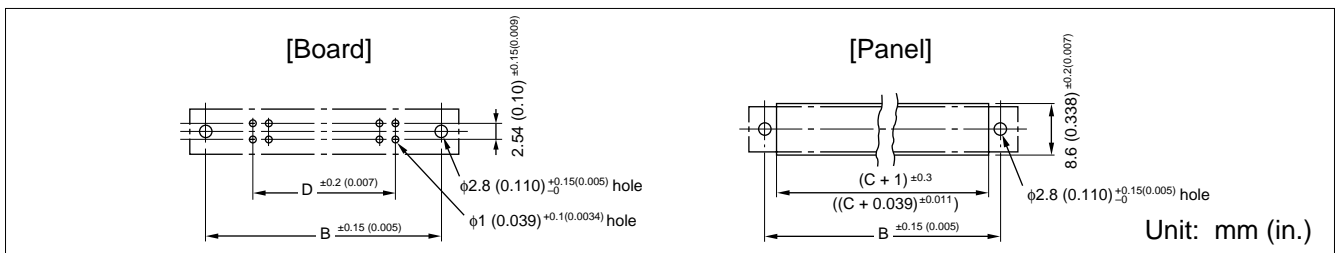

■ PART NUMBERS AND DIMENSIONS

Number of contacts	Part number	Dimensions: mm (in.)			
		A	B	C	D
8	FCN-362J008-AU	28.84 (1.135)	23.34 (0.918)	17.84 (0.702)	7.62 (0.3)
16	FCN-362J016-AU	39.0 (1.535)	33.5 (1.318)	28.0 (1.102)	17.78 (0.7)
24	FCN-362J024-AU	49.16 (1.935)	43.66 (1.718)	38.16 (1.502)	27.94 (1.1)
32	FCN-362J032-AU	59.32 (2.335)	53.82 (2.118)	48.32 (1.902)	38.1 (1.5)
40	FCN-362J040-AU	69.48 (2.735)	63.98 (2.518)	58.48 (2.302)	48.26 (1.9)
48	FCN-362J048-AU	79.64 (3.135)	74.14 (2.918)	68.64 (2.702)	58.42 (2.3)
56	FCN-362J056-AU	89.8 (3.535)	84.3 (3.318)	78.8 (3.102)	68.58 (2.7)
64	FCN-362J064-AU	99.96 (3.935)	94.46 (3.718)	88.96 (3.502)	78.74 (3.1)

FCN-360 Series

CRIMP TYPE (JACK HOUSING)

■ DIMENSIONS



■ MOUNTING HOLE LAYOUT



■ PART NUMBERS AND DIMENSIONS

Number of contacts	Part number	Dimensions: mm (in.)			
		A	B	C	D
8	FCN-363J008	28.84 (1.135)	23.34 (0.918)	17.84 (0.702)	7.62 (0.3)
16	FCN-363J016	39.0 (1.535)	33.5 (1.318)	28.0 (1.102)	17.78 (0.7)
24	FCN-363J024	49.16 (1.935)	43.66 (1.718)	38.16 (1.502)	27.94 (1.1)
32	FCN-363J032	59.32 (2.335)	53.82 (2.118)	48.32 (1.902)	38.1 (1.5)
40	FCN-363J040	69.48 (2.735)	63.98 (2.518)	58.48 (2.302)	48.26 (1.9)
48	FCN-363J048	79.64 (3.135)	74.14 (2.918)	68.64 (2.702)	58.42 (2.3)
56	FCN-363J056	89.8 (3.535)	84.3 (3.318)	78.8 (3.102)	68.58 (2.7)
64	FCN-363J064	99.96 (3.935)	94.46 (3.718)	88.96 (3.502)	78.74 (3.1)

FCN-360 Series

CRIMP TYPE (CONTACT)

■ DIMENSIONS

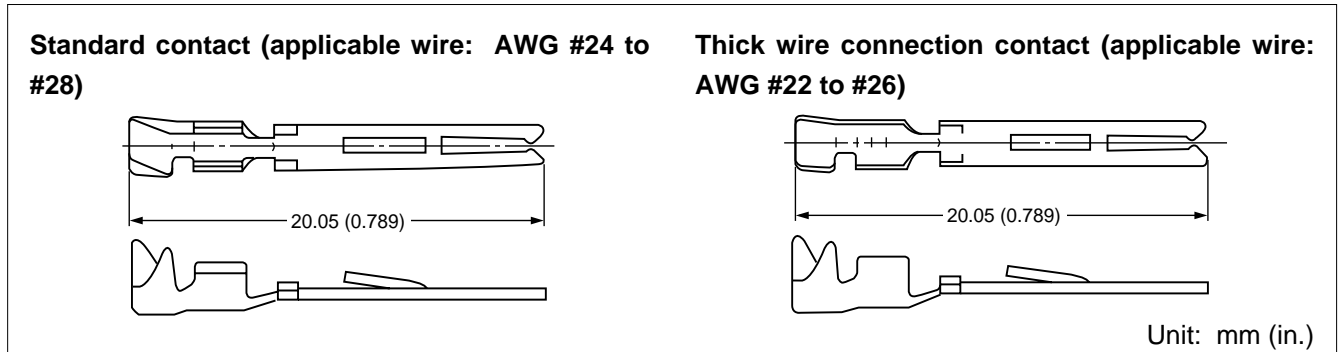

■ PART NUMBERS

Type	Plating	Standard	Thick wire connection contact
Loose piece	Gold plating	FCN-363J-AU	FCN-363J-AU/S
Strip reeled	Gold plating	FCN-363J-AU/R	FCN-363J-AU/T

■ PART NUMBERS OF CRIMPING TOOLS

Part number	Contact type	Applicable wire	Wire cross-section area (mm ²)	Crimp height	Insulator diameter	Stripped length
FCN-363T-T005/H (Hand crimping tool)	FCN-363J-AU (Loose piece)	AWG #24	0.20 to 0.24	1.25 mm (0.049 in.) to 1.30 mm (0.051 in.)	φ1.2 mm (0.047 in.) max	3.0 mm (0.118 in.) to 4.0 mm (0.157 in.)
FCN-M110 (Automatic crimping machine)	FCN-363J-AU/R (Strip reeled)	AWG #26	0.13 to 0.16	1.20 mm (0.047 in.) to 1.25 mm (0.049 in.)	φ1.2 mm (0.047 in.) max	3.0 mm (0.118 in.) to 4.0 mm (0.157 in.)
FCN-A105 (Applicator)		AWG #28	0.088 to 0.096	1.15 mm (0.045 in.) to 1.20 mm (0.047 in.)	φ1.2 mm (0.047 in.) max	3.0 mm (0.118 in.) to 4.0 mm (0.157 in.)
FCN-363T-T011/H (Hand crimping tool)	FCN-363J-AU/S (Loose piece)	AWG #22	0.30 to 0.40	0.85 mm (0.033 in.) to 0.95 mm (0.037 in.)	φ0.9 mm (0.035 in.) 1.8 mm (0.071 in.)	3.0 mm (0.118 in.) to 4.0 mm (0.157 in.)
FCN-M110 (Automatic crimping machine)	FCN-363J-AU/T (Strip reeled)	AWG #24	0.20 to 0.24	0.75 mm (0.029 in.) to 0.85 mm (0.033 in.)	φ0.9 mm (0.035 in.) 1.8 mm (0.071 in.)	3.0 mm (0.118 in.) to 4.0 mm (0.157 in.)
FCN-A111 (Applicator)		AWG #26	0.13 to 0.16	0.73 mm (0.028 in.) to 0.81 mm (0.031 in.)	φ0.9 mm (0.035 in.) 1.8 mm (0.071 in.)	3.0 mm (0.118 in.) to 4.0 mm (0.157 in.)



STRAIGHT TYPE (PLUG)

■ DIMENSIONS



■ BOARD MOUNTING HOLE LAYOUT



■ PART NUMBERS AND DIMENSIONS

Number of contacts	Part number	Dimensions: mm (in.)			
		A	B	C	D
8	FCN-364P008-AU	28.84 (1.135)	23.34 (0.918)	17.84 (0.702)	7.62 (0.3)
16	FCN-364P016-AU	39.0 (1.535)	33.5 (1.318)	28.0 (1.102)	17.78 (0.7)
24	FCN-364P024-AU	49.16 (1.935)	43.66 (1.718)	38.16 (1.502)	27.94 (1.1)
32	FCN-364P032-AU	59.32 (2.335)	53.82 (2.118)	48.32 (1.902)	38.1 (1.5)
40	FCN-364P040-AU	69.48 (2.735)	63.98 (2.518)	58.48 (2.302)	48.26 (1.9)
48	FCN-364P048-AU	79.64 (3.135)	74.14 (2.918)	68.64 (2.702)	58.42 (2.3)
56	FCN-364P056-AU	89.8 (3.535)	84.3 (3.318)	78.8 (3.102)	68.58 (2.7)
64	FCN-364P064-AU	99.96 (3.935)	94.46 (3.718)	88.96 (3.502)	78.74 (3.1)

STRAIGHT TYPE (JACK)

■ DIMENSIONS



■ BOARD MOUNTING HOLE LAYOUT



■ PART NUMBERS AND DIMENSIONS

Number of contacts	Part number	Dimensions: mm (in.)			
		A	B	C	D
8	FCN-364J008-AU	28.84 (1.135)	23.34 (0.918)	17.84 (0.702)	7.62 (0.3)
16	FCN-364J016-AU	39.0 (1.535)	33.5 (1.318)	28.0 (1.102)	17.78 (0.7)
24	FCN-364J024-AU	49.16 (1.935)	43.66 (1.718)	38.16 (1.502)	27.94 (1.1)
32	FCN-364J032-AU	59.32 (2.335)	53.82 (2.118)	48.32 (1.902)	38.1 (1.5)
40	FCN-364J040-AU	69.48 (2.735)	63.98 (2.518)	58.48 (2.302)	48.26 (1.9)
48	FCN-364J048-AU	79.64 (3.135)	74.14 (2.918)	68.64 (2.702)	58.42 (2.3)
56	FCN-364J056-AU	89.8 (3.535)	84.3 (3.318)	78.8 (3.102)	68.58 (2.7)
64	FCN-364J064-AU	99.96 (3.935)	94.46 (3.718)	88.96 (3.502)	78.74 (3.1)

RIGHT-ANGLE TYPE (PLUG)

■ DIMENSIONS



■ MOUNTING HOLE LAYOUT



■ NOTE

- **Note on mounting a right-angle plug on a board**



Mount the connector so that it projects from the board by at least 1.5 mm (0.059 in.).

■ PART NUMBERS AND DIMENSIONS

Number of contacts	Part number	Dimensions: mm (in.)			
		A	B	C	D
8	FCN-365P008-AU	28.84 (1.135)	23.34 (0.918)	17.84 (0.702)	7.62 (0.3)
16	FCN-365P016-AU	39.0 (1.535)	33.5 (1.318)	28.0 (1.102)	17.78 (0.7)
24	FCN-365P024-AU	49.16 (1.935)	43.66 (1.718)	38.16 (1.502)	27.94 (1.1)
32	FCN-365P032-AU	59.32 (2.335)	53.82 (2.118)	48.32 (1.902)	38.1 (1.5)
40	FCN-365P040-AU	69.48 (2.735)	63.98 (2.518)	58.48 (2.302)	48.26 (1.9)
48	FCN-365P048-AU	79.64 (3.135)	74.14 (2.918)	68.64 (2.702)	58.42 (2.3)
56	FCN-365P056-AU	89.8 (3.535)	84.3 (3.318)	78.8 (3.102)	68.58 (2.7)
64	FCN-365P064-AU	99.96 (3.935)	94.46 (3.718)	88.96 (3.502)	78.74 (3.1)

RIGHT-ANGLE TYPE (FOR DUAL STACKED MOUNTING [40 CONTACTS ONLY])

■ DIMENSIONS

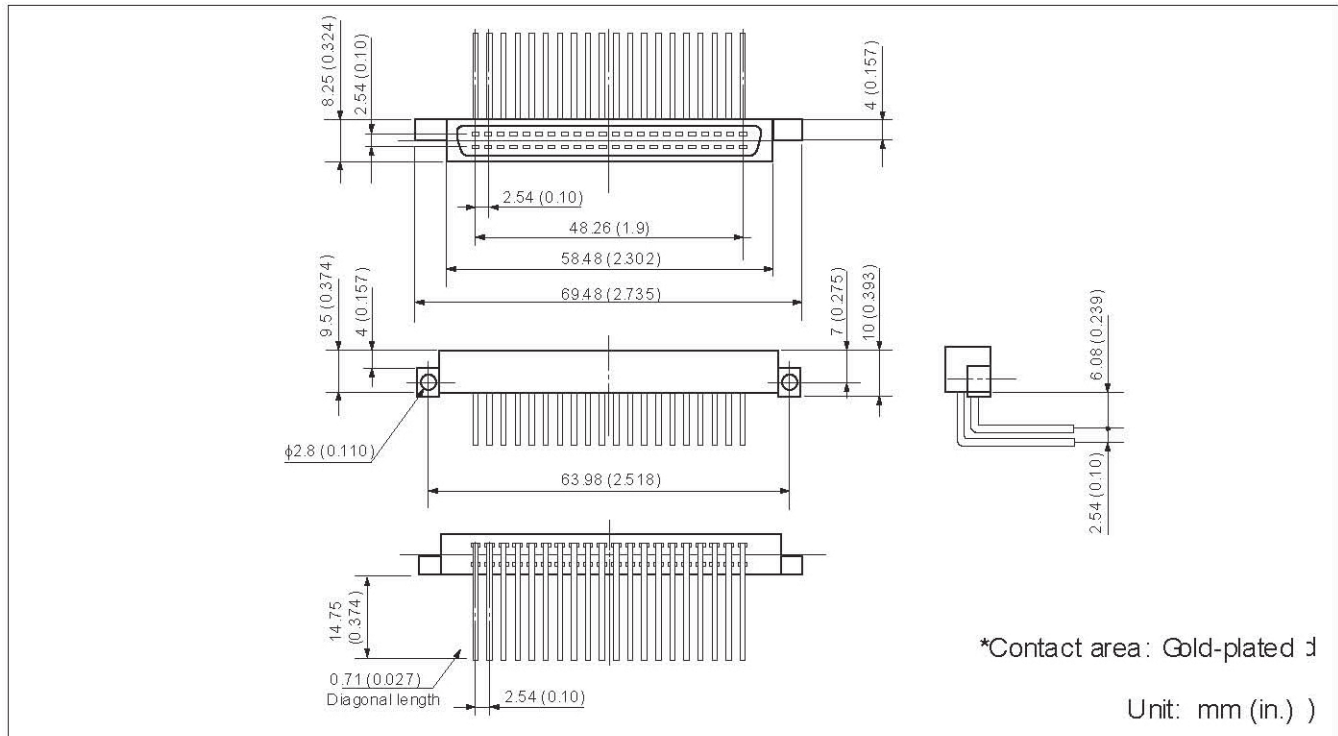

■ MOUNTING HOLE LAYOUT



■ METAL FITTINGS FOR DUAL ROW MOUNTING

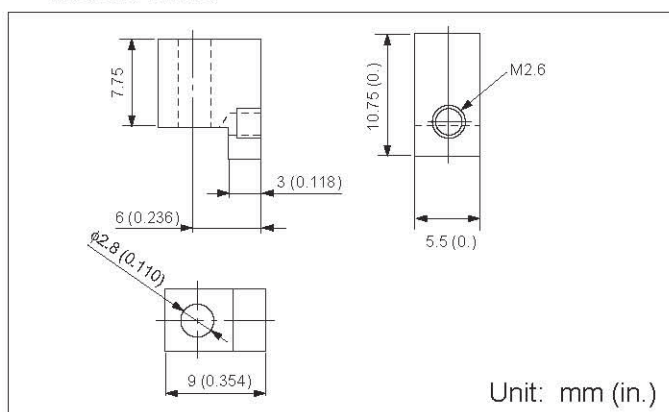

■ PART NUMBER

Right-angle type: N630-3651-T919
Metal fittings: N630-3608-X038

■ MOUNTING

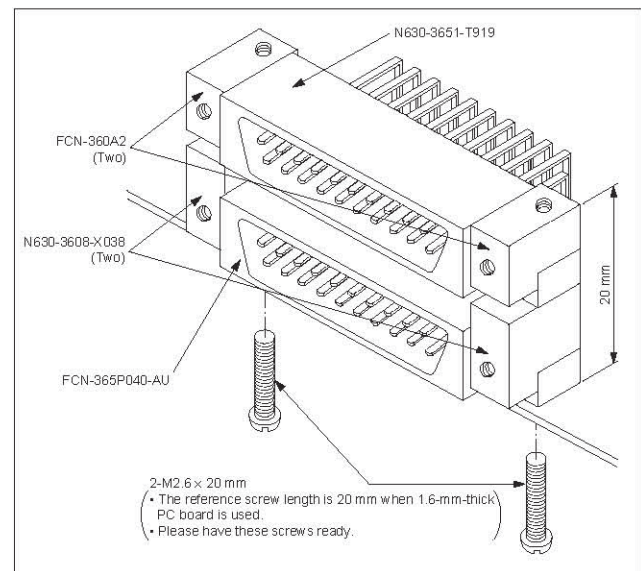

RIGHT-ANGLE TYPE (JACK)

■ DIMENSIONS

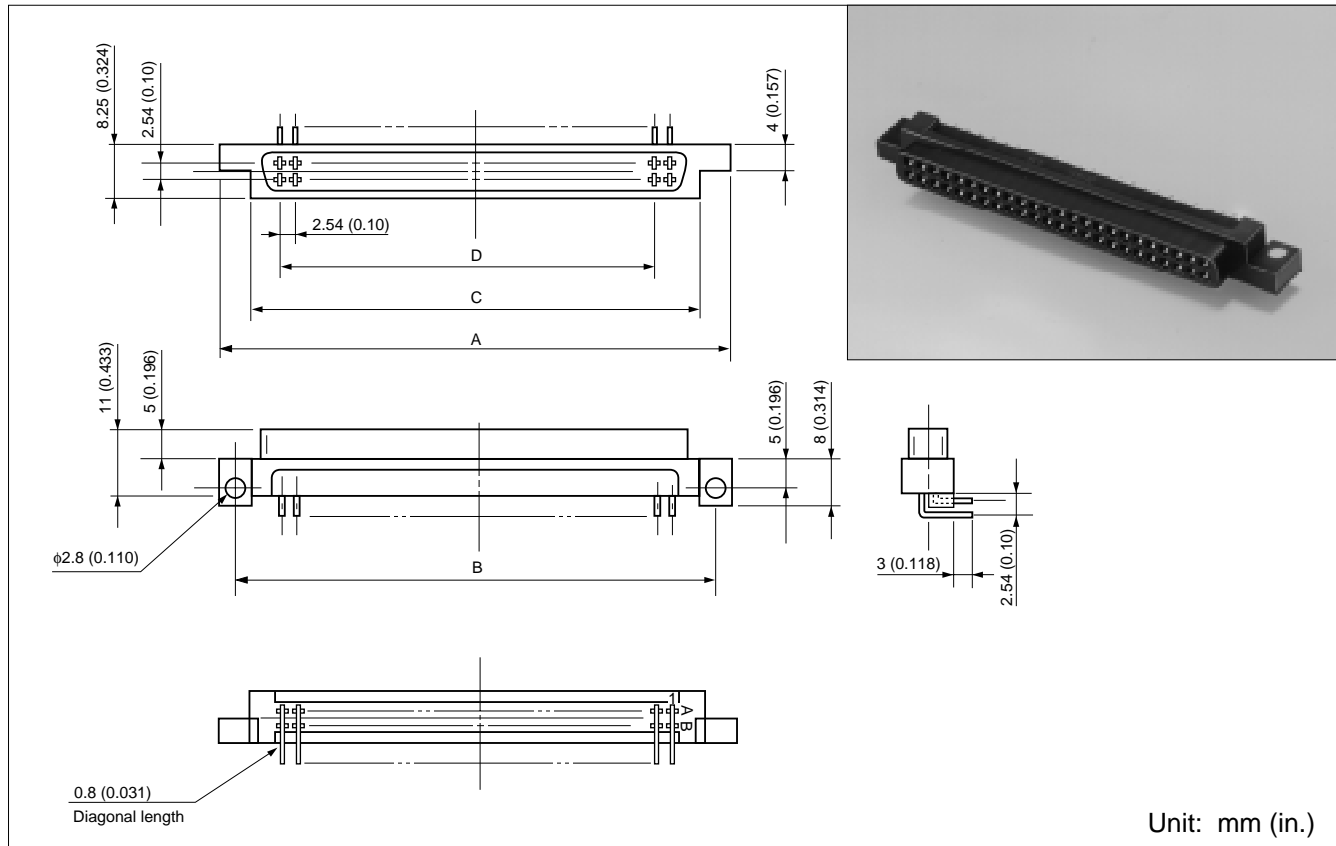

■ MOUNTING HOLE LAYOUT

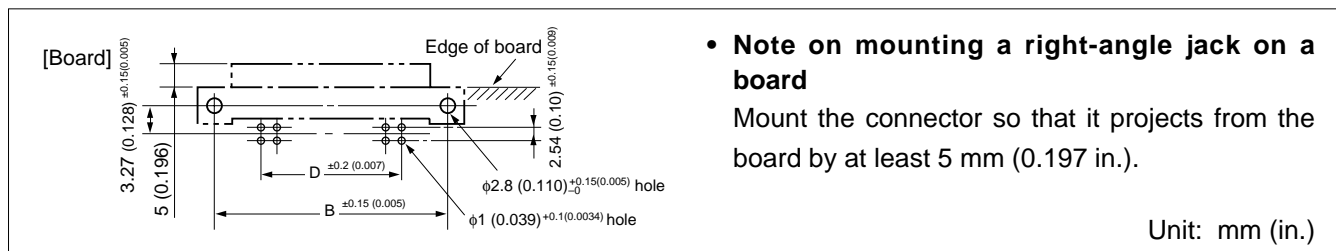

■ PART NUMBERS AND DIMENSIONS

Number of contacts	Part number	Dimensions: mm (in.)			
		A	B	C	D
8	FCN-365J008-AU	28.84 (1.135)	23.34 (0.918)	17.84 (0.702)	7.62 (0.3)
16	FCN-365J016-AU	39.0 (1.535)	33.5 (1.318)	28.0 (1.102)	17.78 (0.7)
24	FCN-365J024-AU	49.16 (1.935)	43.66 (1.718)	38.16 (1.502)	27.94 (1.1)
32	FCN-365J032-AU	59.32 (2.335)	53.82 (2.118)	48.32 (1.902)	38.1 (1.5)
40	FCN-365J040-AU	69.48 (2.735)	63.98 (2.518)	58.48 (2.302)	48.26 (1.9)
48	FCN-365J048-AU	79.64 (3.135)	74.14 (2.918)	68.64 (2.702)	58.42 (2.3)
56	FCN-365J056-AU	89.8 (3.535)	84.3 (3.318)	78.8 (3.102)	68.58 (2.7)
64	FCN-365J064-AU	99.96 (3.935)	94.46 (3.718)	88.96 (3.502)	78.74 (3.1)

FCN-360 Series

IDC TYPE (JACK)

■ DIMENSIONS



■ PART NUMBERS AND DIMENSIONS

Number of contacts	Part number		Dimensions: mm (in.)		
	Through-end cover	Close-end cover	A	B	D
8	FCN-367J008-AU/H	FCN-367J008-AU/F	28.84 (1.135)	23.34 (0.918)	7.62 (0.3)
16	FCN-367J016-AU/H	FCN-367J016-AU/F	39.0 (1.535)	33.5 (1.318)	17.78 (0.7)
24	FCN-367J024-AU/H	FCN-367J024-AU/F	49.16 (1.935)	43.66 (1.718)	27.94 (1.1)
32	FCN-367J032-AU/H	FCN-367J032-AU/F	59.32 (2.335)	53.82 (2.118)	38.1 (1.5)
40	FCN-367J040-AU/H	FCN-367J040-AU/F	69.48 (2.735)	63.98 (2.518)	48.26 (1.9)
48	FCN-367J048-AU/H	FCN-367J048-AU/F	79.64 (3.135)	74.14 (2.918)	58.42 (2.3)
56	FCN-367J056-AU/H	FCN-367J056-AU/F	89.8 (3.535)	84.3 (3.318)	68.58 (2.7)
64	FCN-367J064-AU/H	FCN-367J064-AU/F	99.96 (3.935)	94.46 (3.718)	78.74 (3.1)

IDC TOOLS

Special IDC tools are used to assemble FCN-360 series connectors and flat cables.

■ FEATURES

- The mechanisms are simple, so even novices can use them easily.
- Those who already have Fujitsu-manufactured IDC tools for other series connectors need only purchase the locator plate.

The hand press and cable cutter are designed to be used in common with all connectors.

- The assembly of cables and connectors with various numbers of contacts can be done by selective setting of the connector guides to the specified positions.
- The cable cutter has an extremely sharp cutting edge.

Notes:

- A detailed operation manual and instruction manual for IDC tools are available upon request.
- Should any question arise in using the IDC tools, consult our branch offices or agents in your area.



Hand press

Cable cutter

Locator plate (That for the 790 series is shown in the photograph.)

■ ORDERING CODES FOR IDC TOOLS

Tool name	Part number
Cable cutter (common)	FCN-707T-T001/H
Hand press (common)	FCN-707T-T101/H
Locator plate (for 360 series connectors)	FCN-367T-T012/H

The hand press and cable cutter can be used for other IDC connectors.

COVER

■ COMBINATIONS BETWEEN COVERS AND CONNECTORS

Connector Cover	Plug	Jack			Number of contacts							
	Soldering	Soldering	Wire-wrapping	Crimping	8	16	24	32	40	48	56	64
FCN-360C□□□-B	○	○	○	○	○	○	○	○	○	○	○	○
FCN-360C□□□-C	○	○	○	○	○	○	○	○	○	○	○	○
FCN-360C□□□-D	○	○	○	○					○	○	○	○
FCN-360C□□□-E	○	○	○	○	○	○	○	○	○	○	○	○
FCN-360C064-F	○	○	○	○								○
FCN-360C040-G1	○	○	○	○					○			
FCN-360C040-H/E	○	○							○			
FCN-360C040-J1	○	○							○			

These covers cannot be used for IDC connectors.

FCN-360 Series

COVER (TYPE B)

■ DIMENSIONS



■ EXPLODED VIEW

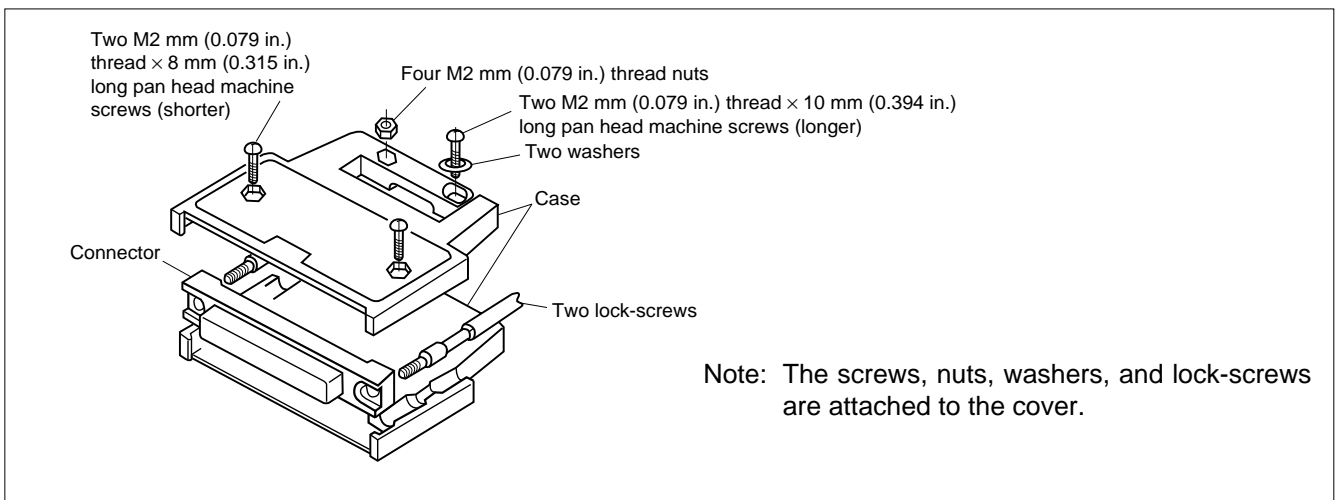

■ PART NUMBERS AND DIMENSIONS

Number of contacts	Part number	Dimensions: mm (in.)			
		B	F	G	H
8	FCN-360C008-B	23.34 (0.918)	32.08 (1.262)	—	∅ 5.7 (0.224)
16	FCN-360C016-B	33.50 (1.318)	42.24 (1.662)	—	∅ 5.7 (0.224)
24	FCN-360C024-B	43.66 (1.718)	52.40 (2.062)	—	∅ 8.0 (0.314)
32	FCN-360C032-B	53.82 (2.118)	62.56 (2.462)	2.0 (0.078)	8.0 (0.314)
40	FCN-360C040-B	63.98 (2.518)	72.72 (2.862)	6.0 (0.236)	8.0 (0.314)
48	FCN-360C048-B	74.14 (2.918)	82.88 (3.262)	10.0 (0.393)	8.0 (0.314)
56	FCN-360C056-B	84.30 (3.318)	93.04 (3.662)	14.0 (0.551)	8.0 (0.314)
64	FCN-360C064-B	94.46 (3.718)	103.20 (4.062)	18.0 (0.708)	8.0 (0.314)

FCN-360 Series

COVER FOR CABLE TO CABLE CONNECTION (TYPE C)

■ DIMENSIONS



■ EXPLODED VIEW

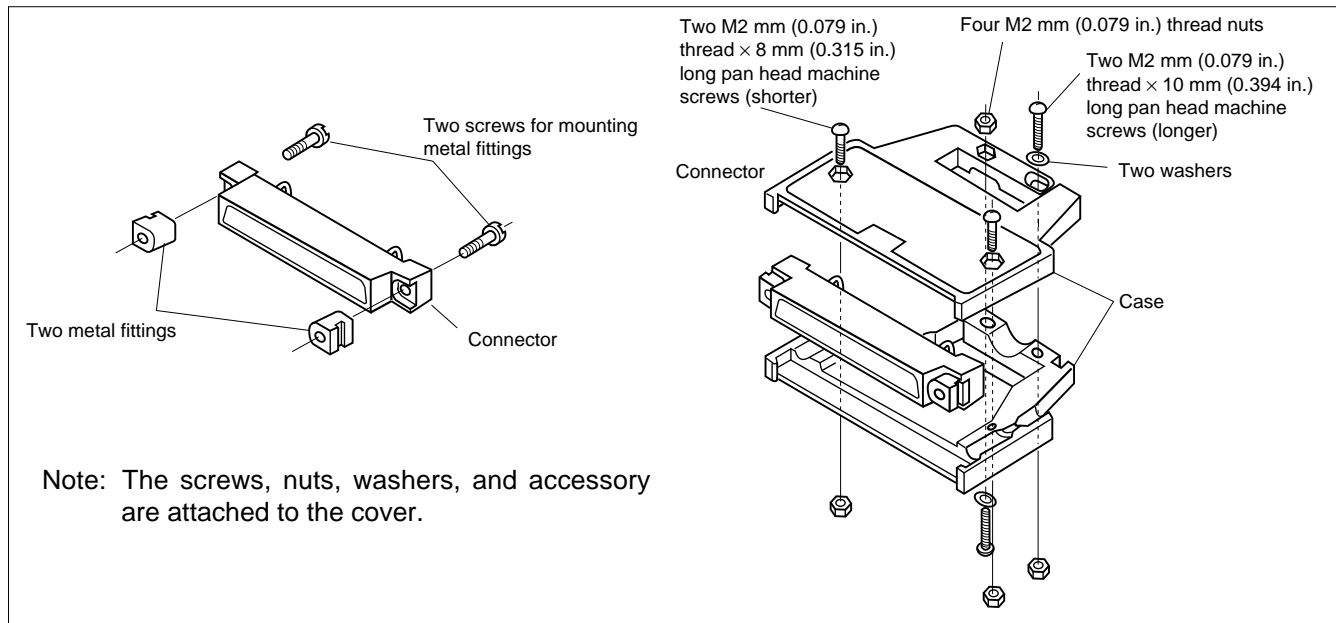

■ PART NUMBERS AND DIMENSIONS

Number of contacts	Part number	Dimensions: mm (in.)		
		F	G	H
8	FCN-360C008-C	32.08 (1.262)	—	φ 5.7 (0.224)
16	FCN-360C016-C	42.24 (1.662)	—	φ 5.7 (0.224)
24	FCN-360C024-C	52.40 (2.062)	—	φ 8.0 (0.314)
32	FCN-360C032-C	62.56 (2.462)	2.0 (0.078)	8.0 (0.314)
40	FCN-360C040-C	72.72 (2.862)	6.0 (0.236)	8.0 (0.314)
48	FCN-360C048-C	82.88 (3.262)	10.0 (0.393)	8.0 (0.314)
56	FCN-360C056-C	93.04 (3.662)	14.0 (0.551)	8.0 (0.314)
64	FCN-360C064-C	103.20 (4.062)	18.0 (0.708)	8.0 (0.314)

FCN-360 Series

COVER (WIDE OPENING TYPE) (TYPE D)

■ DIMENSIONS

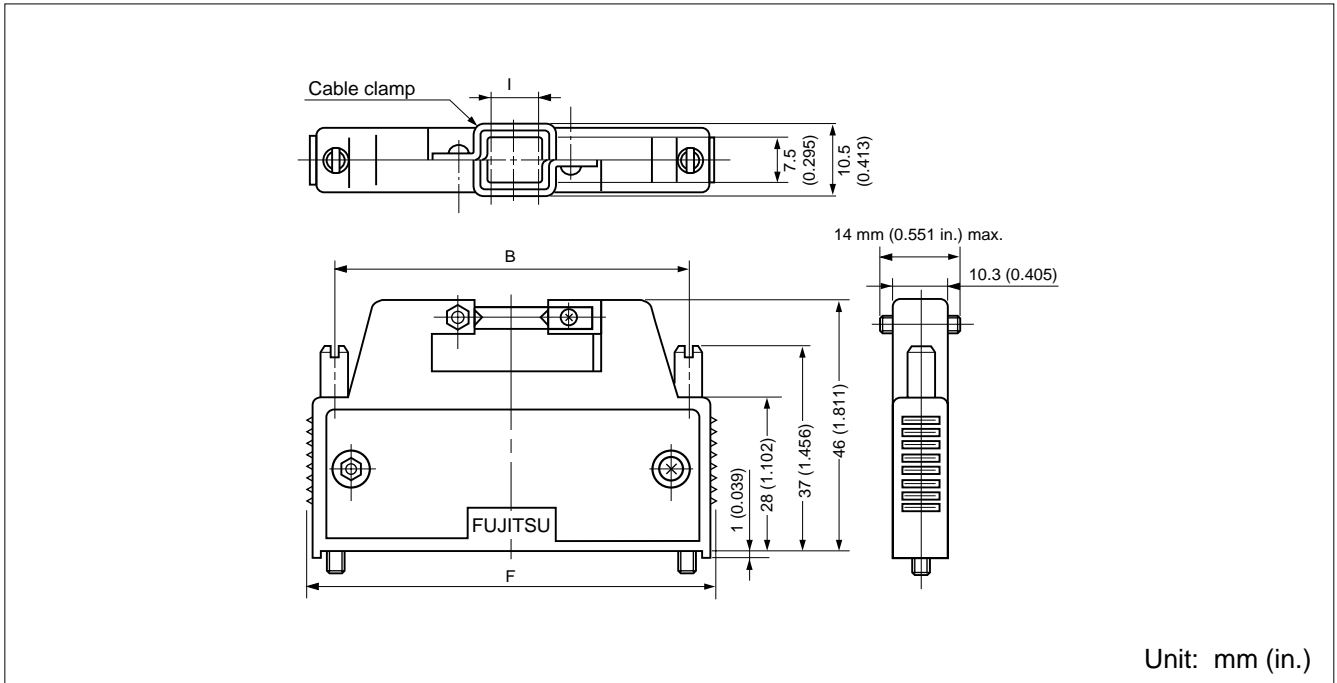

■ EXPLODED VIEW



■ PART NUMBERS AND DIMENSIONS

Number of contacts	Part number	Dimensions: mm (in.)		
		B	F	I
40	FCN-360C040-D	63.98 (2.518)	72.72 (2.862)	8.0 (0.314)
48	FCN-360C048-D	74.14 (2.918)	82.88 (3.262)	12.0 (0.472)
56	FCN-360C056-D	84.30 (3.318)	93.04 (3.662)	16.0 (0.629)
64	FCN-360C064-D	94.46 (3.718)	103.20 (4.062)	20.0 (0.789)

FCN-360 Series

COVER (LONG-SCREW TYPE) (TYPE E)

■ DIMENSIONS

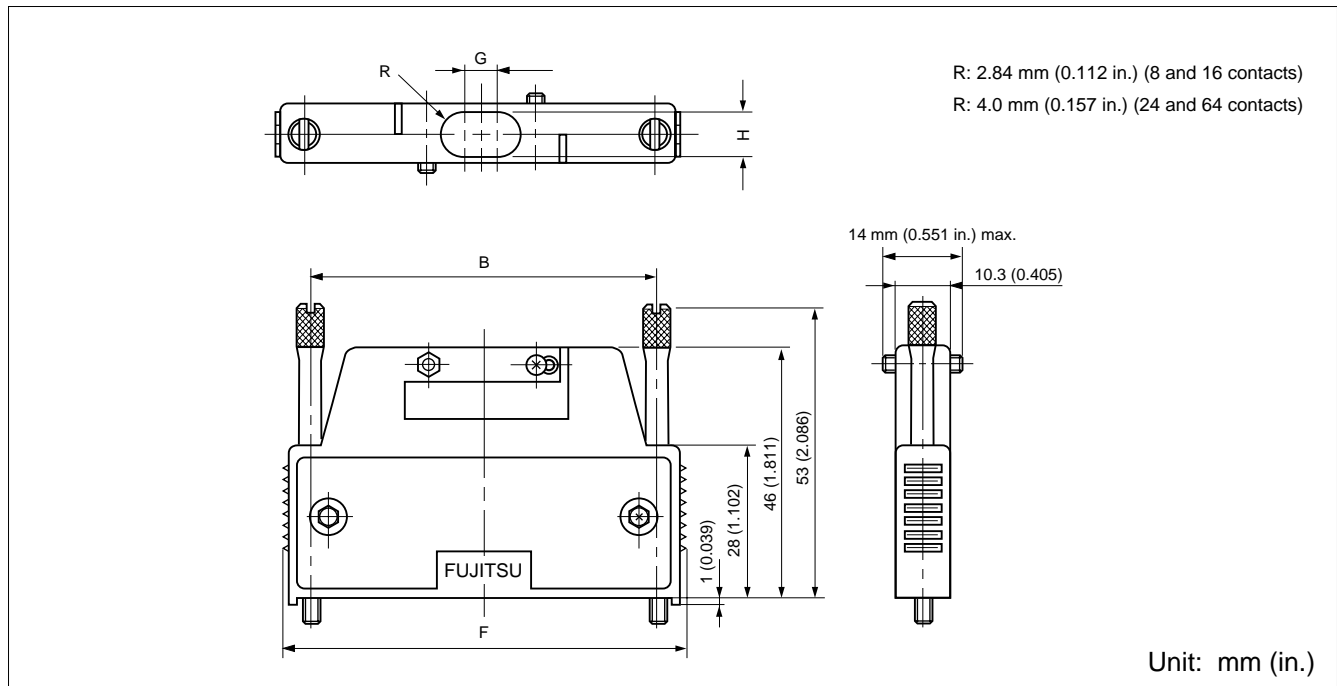

■ EXPLODED VIEW

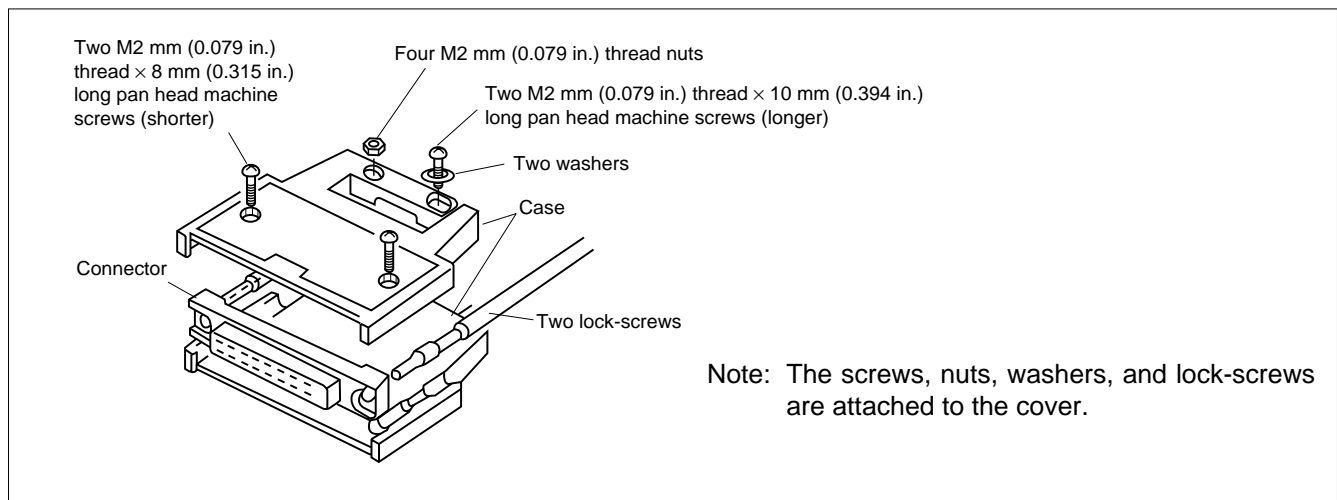

■ PART NUMBERS AND DIMENSIONS

Number of contacts	Part number	Dimensions: mm (in.)			
		B	F	G	H
8	FCN-360C008-E	23.34 (0.918)	32.08 (1.262)	—	φ 5.7 (0.224)
16	FCN-360C016-E	33.50 (1.318)	42.24 (1.662)	—	φ 5.7 (0.224)
24	FCN-360C024-E	43.66 (1.718)	52.40 (2.062)	—	φ 8.0 (0.314)
32	FCN-360C032-E	53.82 (2.118)	62.56 (2.462)	2.0 (0.078)	8.0 (0.314)
40	FCN-360C040-E	63.98 (2.518)	72.72 (2.862)	6.0 (0.236)	8.0 (0.314)
48	FCN-360C048-E	74.14 (2.918)	82.88 (3.262)	10.0 (0.393)	8.0 (0.314)
56	FCN-360C056-E	84.30 (3.318)	93.04 (3.662)	14.0 (0.551)	8.0 (0.314)
64	FCN-360C064-E	94.46 (3.718)	103.20 (4.062)	18.0 (0.708)	8.0 (0.314)

COVER (STRAIGHT CABLE-OUT COVER) (TYPE F)

■ DIMENSIONS

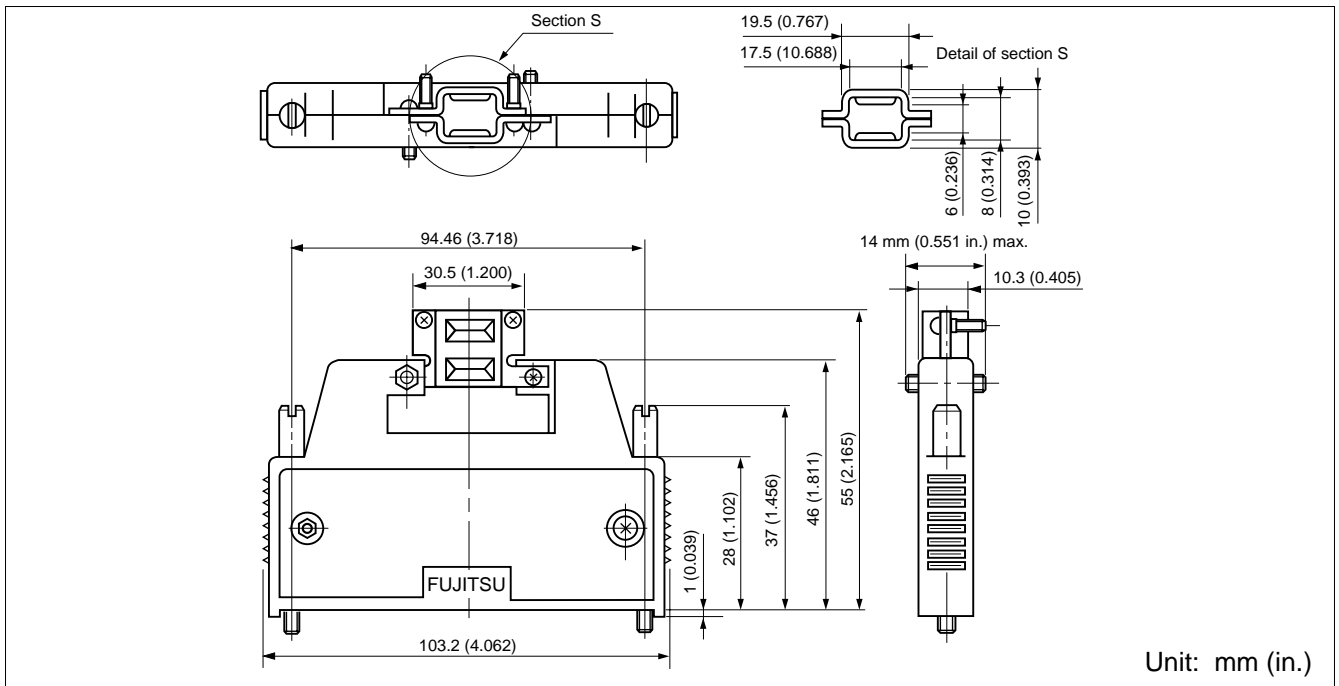

■ EXPLODED VIEW



■ PART NUMBER

FCN-360C064-F

FCN-360 Series

COVER (RIGHT ANGLE CABLE-OUT COVER) (TYPE G1)

■ DIMENSIONS

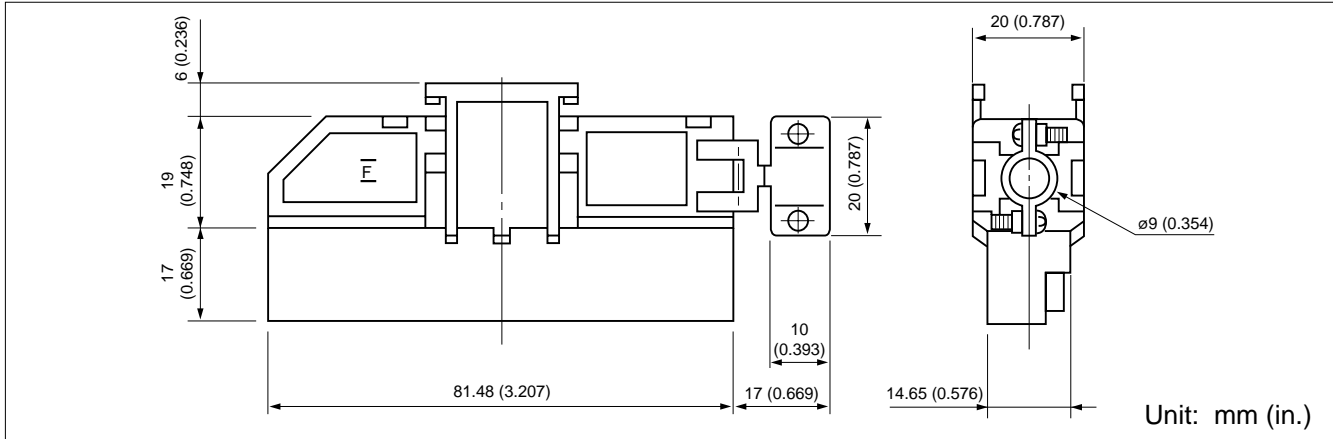

■ EXPLODED VIEW

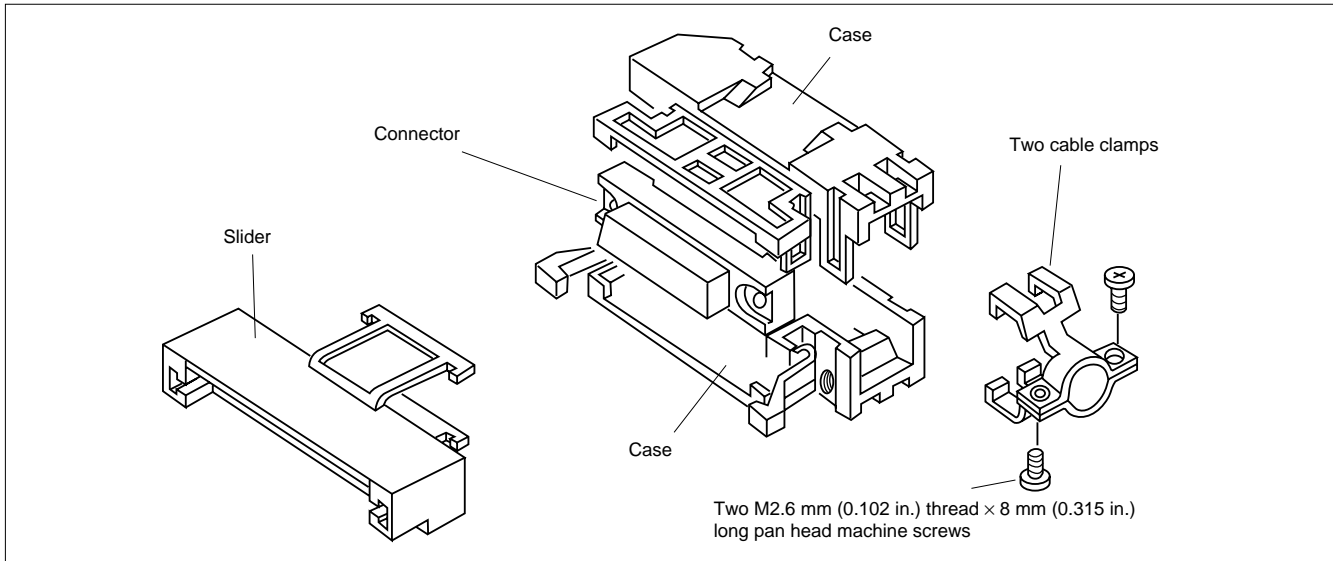

■ LOCKED STATE



■ METAL FITTINGS

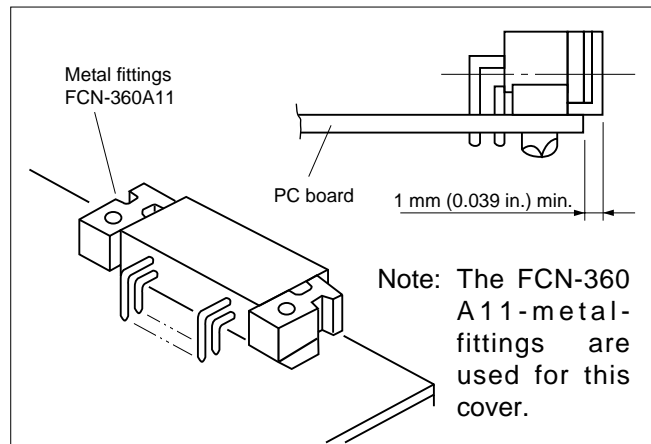

■ PART NUMBER

FCN-360C040-G1

FCN-360 Series

COVER (RIGHT ANGLE CABLEOUT COVER) (TYPE H/E)

■ DIMENSIONS

Material: Zinc die cast

Plating: Nickel plating

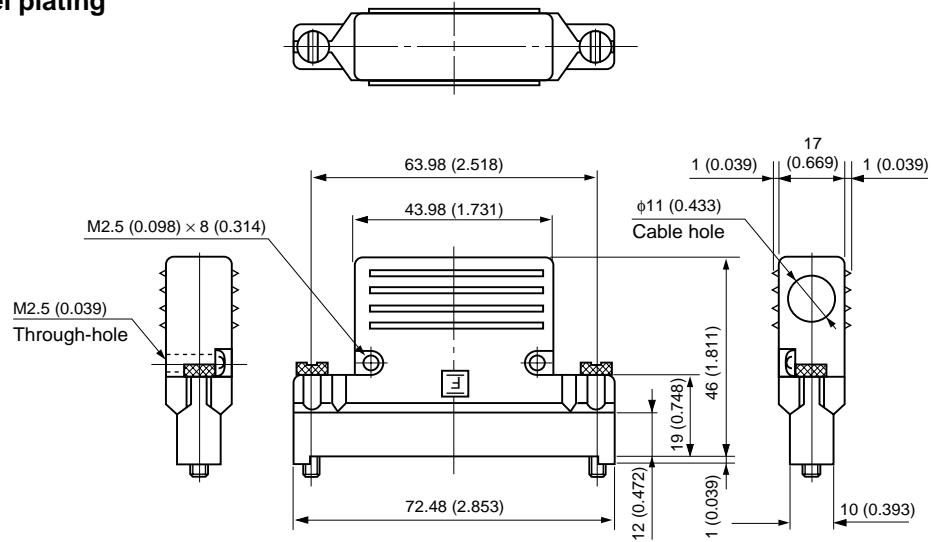

Unit: mm (in.)

■ EXPLODED VIEW



Note: The screws, cable clamp, and lock-screws are attached to the cover.

■ PART NUMBER

FCN-360C040-H/E

FCN-360 Series

COVER (OBTUSE ANGLE CABLE-OUT COVER (40 CONTACTS ONLY)) (TYPE J1)

■ DIMENSIONS



■ EXPLODED VIEW



■ PART NUMBER

FCN-360C040-J1

FCN-360 Series

LOW PROFILE COVER (OBTUSE ANGLE CABLE -OUT) (TYPE J2)

■ DIMENSION

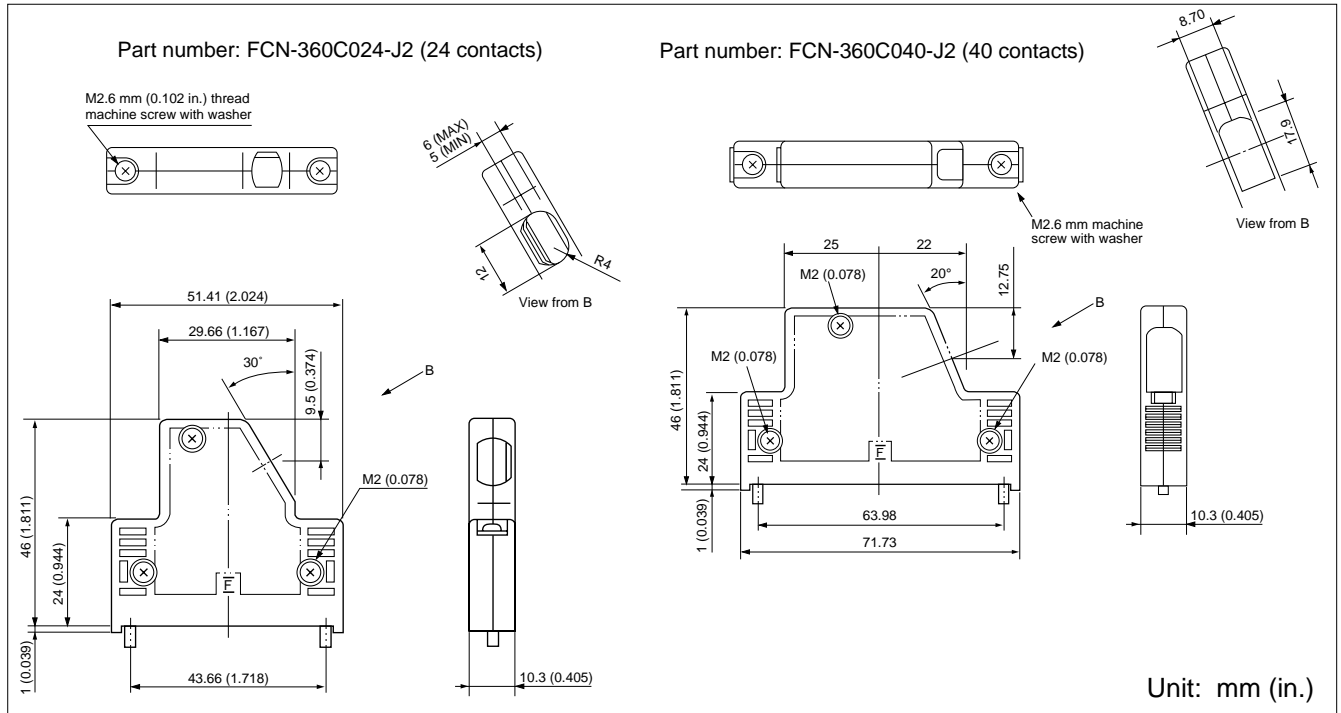

■ EXPLODED VIEW



■ PART NUMBER

FCN-360C024-J2

FCN-360C040-J2

ACCESSORIES

■ MOUNTING SYLE



■ SELECTION OF METAL FITTINGS ACCORDING TO COMBINATION OF CONNECTORS AND COVERS

Jack / Plug			Cover mounting side									
			361J		362J		363J		364J		367J	
			With cover	Without cover	With cover	Without cover	With cover	Without cover	With cover	Without cover	With cover	Without cover
Metal fitting mounting side	361P	Metal fitting part number	FCN-360A4	FCN-360A5	FCN-360A4	FCN-360A5	FCN-360A4	FCN-360A5	FCN-360A4	FCN-360A5	—	FCN-360A5
	362P		FCN-360A1	FCN-360A6	FCN-360A1	FCN-360A6	FCN-360A1	FCN-360A6	FCN-360A1	FCN-360A6	—	FCN-360A6
	364P		FCN-360A1	FCN-360A6	FCN-360A1	FCN-360A6	FCN-360A1	FCN-360A6	FCN-360A1	FCN-360A6	—	FCN-360A6
	365P		FCN-360A2	FCN-360A3	FCN-360A2	FCN-360A3	FCN-360A2	FCN-360A3	FCN-360A2	FCN-360A3	—	FCN-360A3

Jack / Plug			Cover mounting side					
			361P		361P		364P	
			With cover	Without cover	With cover	Without cover	With cover	Without cover
Metal fitting mounting side	361J	Metal fitting part number	FCN-360A4	FCN-360A5	—	FCN-360A7	—	FCN-360A7
	362J		FCN-360A4	FCN-360A5	—	FCN-360A7	—	FCN-360A7
	363J		FCN-360A4	FCN-360A5	—	FCN-360A7	—	FCN-360A7
	364J		FCN-360A4	FCN-360A5	—	FCN-360A7	—	FCN-360A7
	365J		FCN-360A10 (FCN-360A8)	FCN-360A9	—	FCN-360A9	—	FCN-360A9
	367J		FCN-360A4	FCN-360A5	—	FCN-360A7	—	FCN-360A7

Note: When the jack or plug without a cover (shaded part) is used, have M2.6 × 8 mm machine screws ready in order to tighten the connector.

■ SHAPES AND DIMENSIONS OF METAL FITTINGS

1. Straight Mounting Metal Fittings

Shape	Part number		FCN-360A1	FCN-360A6
	Symbol			
	A		5.3 (0.208)	6.3 (0.248)

2. Right-angle Mounting Metal Fittings

Shape	Part number		FCN-360A2	FCN-360A3
	Symbol			
	B		3 (0.118)	4 (0.157)
	C		9 (0.354)	10 (0.393)

Shape	Part number		FCN-360A8	FCN-360A9
	Symbol			
	B		5.3 (0.208)	6.3 (0.248)
	C		13.3 (0.523)	14.3 (0.526)

Symbol	Part number
	FCN-360A10

Symbol	Part number
	FCN-360A11

3. Straight Mounting Round Metal Fittings

Shape	Part number			
	Symbol	FCN-360A4	FCN-360A5	FCN-360A7
	D	7.1 (0.279)	9.9 (0.389)	8.1 (0.318)

Fujitsu Components International Headquarter Offices

Japan

Fujitsu Component Limited
Gotanda-Chuo Building
3-5, Higashigotanda 2-chome, Shinagawa-ku
Tokyo 141, Japan
Tel: (81-3) 5449-7010
Fax: (81-3) 5449-2626
Email: promothq@ft.ed.fujitsu.com
Web: www.fcl.fujitsu.com

North and South America

Fujitsu Components America, Inc.
250 E. Caribbean Drive
Sunnyvale, CA 94089 U.S.A.
Tel: (1-408) 745-4900
Fax: (1-408) 745-4970
Email: marcom@fcai.fujitsu.com
Web: www.fcai.fujitsu.com

Europe

Fujitsu Components Europe B.V.
Diamantlaan 25
2132 WV Hoofddorp
Netherlands
Tel: (31-23) 5560910
Fax: (31-23) 5560950
Email: info.marketing@fceu.fujitsu.com
Web: www.fceu.fujitsu.com

Asia Pacific

Fujitsu Components Asia Ltd.
102E Pasir Panjang Road
#04-01 Citilink Warehouse Complex
Singapore 118529
Tel: (65) 375-8560
Fax: (65) 273-3021
Email: fcal@fcal.fujitsu.com
www.fcal.fujitsu.com

© 2001 Fujitsu Components America, Inc. All company and product names are trademarks or registered trademarks of their respective owners. Rev. 09/2001

Компания «Океан Электроники» предлагает заключение долгосрочных отношений при поставках импортных электронных компонентов на взаимовыгодных условиях!

Наши преимущества:

- Поставка оригинальных импортных электронных компонентов напрямую с производств Америки, Европы и Азии, а так же с крупнейших складов мира;
- Широкая линейка поставок активных и пассивных импортных электронных компонентов (более 30 млн. наименований);
- Поставка сложных, дефицитных, либо снятых с производства позиций;
- Оперативные сроки поставки под заказ (от 5 рабочих дней);
- Экспресс доставка в любую точку России;
- Помощь Конструкторского Отдела и консультации квалифицированных инженеров;
- Техническая поддержка проекта, помощь в подборе аналогов, поставка прототипов;
- Поставка электронных компонентов под контролем ВП;
- Система менеджмента качества сертифицирована по Международному стандарту ISO 9001;
- При необходимости вся продукция военного и аэрокосмического назначения проходит испытания и сертификацию в лаборатории (по согласованию с заказчиком);
- Поставка специализированных компонентов военного и аэрокосмического уровня качества (Xilinx, Altera, Analog Devices, Intersil, Interpoint, Microsemi, Actel, Aeroflex, Peregrine, VPT, Syfer, Eurofarad, Texas Instruments, MS Kennedy, Miteq, Cobham, E2V, MA-COM, Hittite, Mini-Circuits, General Dynamics и др.);

Компания «Океан Электроники» является официальным дистрибьютором и эксклюзивным представителем в России одного из крупнейших производителей разъемов военного и аэрокосмического назначения «**JONHON**», а так же официальным дистрибьютором и эксклюзивным представителем в России производителя высокотехнологичных и надежных решений для передачи СВЧ сигналов «**FORSTAR**».



JONHON

«**JONHON**» (основан в 1970 г.)

Разъемы специального, военного и аэрокосмического назначения:

(Применяются в военной, авиационной, аэрокосмической, морской, железнодорожной, горно- и нефтедобывающей отраслях промышленности)

«**FORSTAR**» (основан в 1998 г.)

ВЧ соединители, коаксиальные кабели,
кабельные сборки и микроволновые компоненты:

(Применяются в телекоммуникациях гражданского и специального назначения, в средствах связи, РЛС, а так же военной, авиационной и аэрокосмической отраслях промышленности).



Телефон: 8 (812) 309-75-97 (многоканальный)

Факс: 8 (812) 320-03-32

Электронная почта: ocean@oceanchips.ru

Web: <http://oceanchips.ru/>

Адрес: 198099, г. Санкт-Петербург, ул. Калинина, д. 2, корп. 4, лит. А