



ZNEO32! Family of Microcontrollers

Z32F384 MCU

Product Specification

PS034602-0316

PRELIMINARY

ZNEO32!
32 Bit Microcontrollers



Warning: DO NOT USE THIS PRODUCT IN LIFE SUPPORT SYSTEMS.

LIFE SUPPORT POLICY

ZILOG'S PRODUCTS ARE NOT AUTHORIZED FOR USE AS CRITICAL COMPONENTS IN LIFE SUPPORT DEVICES OR SYSTEMS WITHOUT THE EXPRESS PRIOR WRITTEN APPROVAL OF THE PRESIDENT AND GENERAL COUNSEL OF ZILOG CORPORATION.

As used herein

Life support devices or systems are devices which (a) are intended for surgical implant into the body, or (b) support or sustain life and whose failure to perform when properly used in accordance with instructions for use provided in the labeling can be reasonably expected to result in a significant injury to the user. A critical component is any component in a life support device or system whose failure to perform can be reasonably expected to cause the failure of the life support device or system or to affect its safety or effectiveness.

Document Disclaimer

©2016 Zilog, Inc. All rights reserved. Information in this publication concerning the devices, applications, or technology described is intended to suggest possible uses and may be superseded. ZILOG, INC. DOES NOT ASSUME LIABILITY FOR OR PROVIDE A REPRESENTATION OF ACCURACY OF THE INFORMATION, DEVICES, OR TECHNOLOGY DESCRIBED IN THIS DOCUMENT. ZILOG ALSO DOES NOT ASSUME LIABILITY FOR INTELLECTUAL PROPERTY INFRINGEMENT RELATED IN ANY MANNER TO USE OF INFORMATION, DEVICES, OR TECHNOLOGY DESCRIBED HEREIN OR OTHERWISE. The information contained within this document has been verified according to the general principles of electrical and mechanical engineering.

ZNEO32! is a trademark or registered trademark of Zilog, Inc. All other product or service names are the property of their respective owners.

Revision History

Each instance in this document's revision history reflects a change from its previous edition. For more details, refer to the corresponding page(s) or appropriate links furnished in the table below.

Date	Revision Level	Description	Page
Mar 2016	02	Updated to reflect new part, revision B (0x0002); Added timing information for most of the peripherals; corrected typos.	All
Dec 2015	01	Original issue.	

1. Overview

Introduction

Zilog's Z32F384 MCU, a member of the ZNEO32! Family of microcontrollers, is a cost-effective and high-performance 32-bit microcontroller. The Z32F384 MCU provides 3-phase PWM generator units which are suitable for inverter bridges, including motor drive systems. Two built-in channels of these generators control two inverter bridges simultaneously.

Two 12-bit high speed ADC units with 16-channel analog multiplexed inputs support feedback retrieval from the inverter bridge. The Z32F384 MCU can control up to two inverter motors or one inverter motor and the Power Factor Correction (PFC) function simultaneously.

Figure 1.1 shows a block diagram of the Z32F384 MCU.

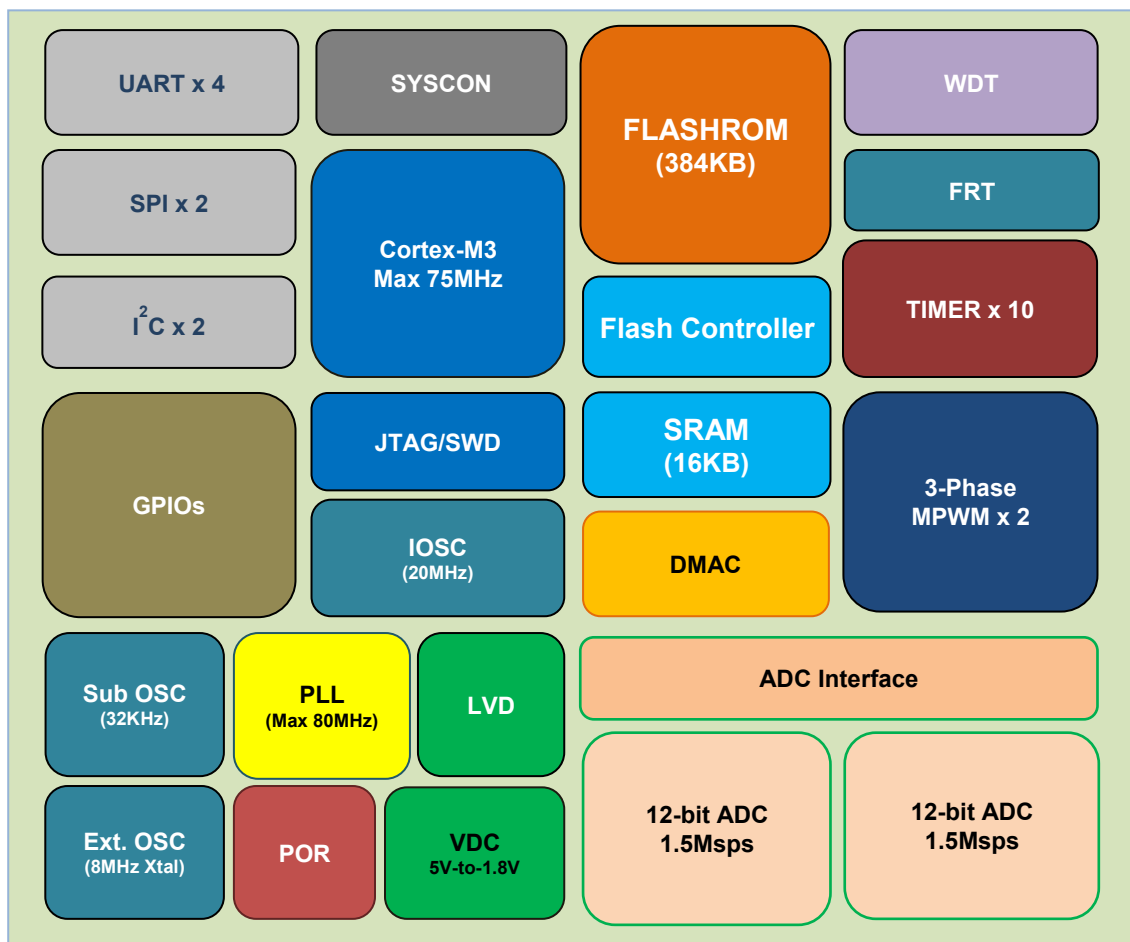

Figure 1.1. Block Diagram

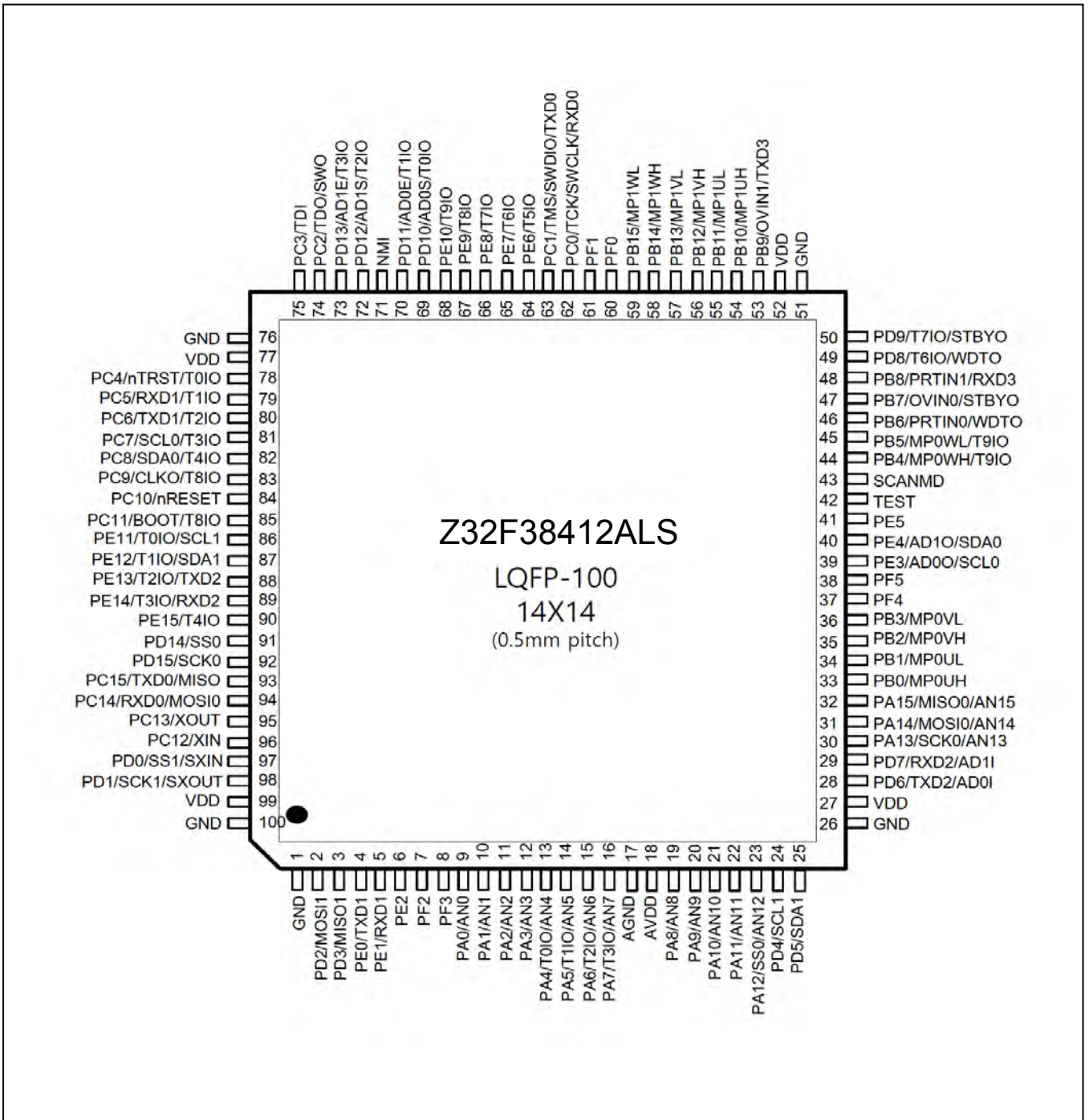

Figure 1.2. Pin Layout (LQFP-100)

Product Features

The Z32F384 MCU includes the following features:

- High performance low-power Cortex-M3 core
- 384KB code Flash memory with cache function
- 16 KB SRAM
- 3-Phase PWM with ADC triggering function
 - 2 Channels
- 1.5 MSPS high-speed ADC with sequential conversion
 - 2 units with 16 Channel input
- System fail-safe function by clock monitoring
 - XTAL OSC fail monitoring function
 - System clock Fail monitoring function
- Internal clock sources
 - Internal ring oscillator (1 MHz \pm 50%)
 - Internal oscillator clock (20 MHz \pm 3%)
 - Internal Phase Lock Loop (PLL) up to 80Mhz
- External clock sources
 - External crystal oscillator (4~16 MHz)
 - External sub oscillator (32 kHz)
- Watchdog timer
- 10 general purpose timer channels
 - Timer/capture/PWM mode
- Free run timer
- Various external communication ports:
 - 4 UARTs
 - 2 I²Cs
 - 2 SPIs
- High current driving port for UART photo couplers
- Direct Memory Access (DMA) controller with 8 channels
- Debug and emergency stop function
- JTAG and SWD debugger
- Package: LQFP-100 (0.5mm pitch)
- Industrial grade operating temperature (– 40 ~ +85°C)

Architecture

Block Diagram

Figure 1.3 shows the Z32F384 MCU's internal block diagram.

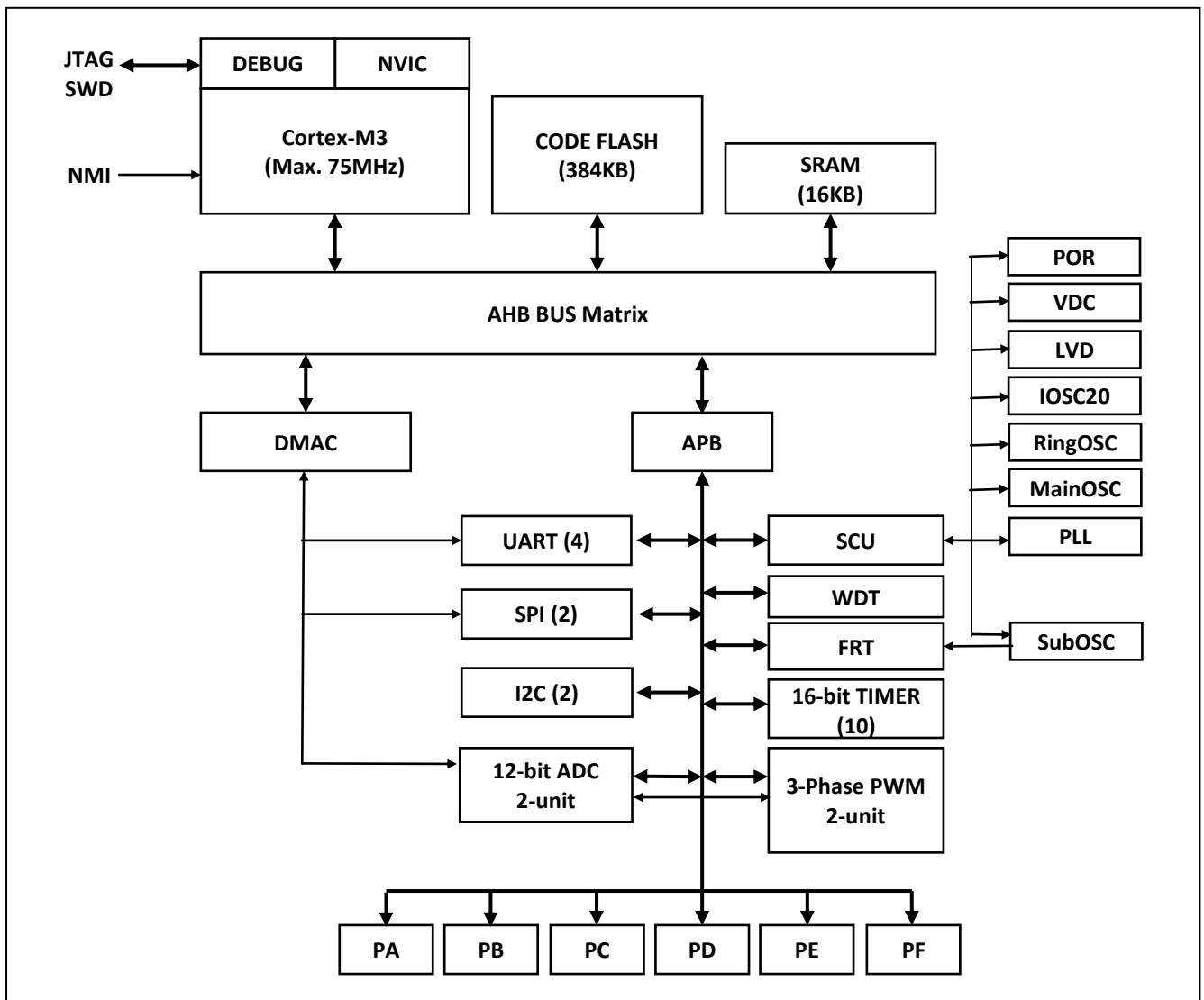

Figure1.3. Internal Block Diagram

Functional Description

The following section provides an overview of the features of the Z32F384 microcontroller.

ARM Cortex-M3

The ARM-powered Cortex-M3 Core based on v7M architecture is optimized for small size and low power system. An on core system timer (SYSTICK) provides a simple 24-bit timer, that enables easy management of the system operation. The thumb-compatible Thumb-2 only instruction set processor core makes code high-density. Hardware division and single-cycle multiplication is present. Integrated Nested Vectored Interrupt Controller (NVIC) provides deterministic interrupt handling. Full featured debug solutions are provided – JTAG and SWD, FPB, DWT, ITM and TPIU. It includes a maximum 72 MHz operating frequency with zero wait execution.

Nested Vector-Interrupt Controller (NVIC)

The ARM Nested Vectored Interrupt Controller (NVIC) on the ARM Cortex-M3 core is included, which handles all internal and external exceptions. When an interrupt condition is detected, the processor state is automatically stored to the stack and automatically restored from the stack at the end of the interrupt service routine. The vector is fetched in parallel to the state saving, which enables efficient interrupt entry. The processor supports tail-chaining, which allows back-to-back interrupts to be performed without the overhead of state saving and restoring.

384 KB Internal Code Flash Memory

The Z32F384 MCU provides internal 384 KB code Flash memory and its controller. This is enough to program the motor algorithm and generally control the system. Self-programming is available and ISP and JTAG programming is also supported in boot or debugging mode.

Instruction and data cache buffer are present and overcome the low bandwidth Flash memory. The CPU can execute from Flash memory with zero wait state up to 72 MHz bus frequency.

16 KB Zero-wait Internal SRAM

On chip 16 KB zero-wait SRAM can be used for working memory space and program code can be loaded on this SRAM.

Boot Logic

The smart boot logic supports Flash programming. The Z32F384 MCU can be accessed by an external boot pin and UART and SPI programming are available in boot mode.

System Control Unit (SCU)

The SCU block manages internal power, clock, reset, and operation mode. It also controls analog blocks (INTOSC, VDC and BOD).

32-bit Watchdog Timer (WDT)

The watchdog timer performs the system monitoring function. It generates an internal reset or interrupt when it notices abnormal status of the system.

Multi-purpose 16-bit Timer

10 16-bit general purpose timers channels support the following functions:

- Periodic timer mode
- Counter mode
- PWM mode
- Capture mode

Free Run Timer

The 32-bit Free run timer has multiple clock sources (XTAL/16, IOSCL/16, SXTAL).

Motor PWM Generator

Two channels of the 3-phase PWM generator are implemented. A 16-bit up/down counter with prescaler

supports both the triangular and saw tooth waveform.

The PWM generates an internal ADC trigger signal to measure the signal on time. Dead time insertion and emergency stop functionality ensure that the chip and system operate under safe conditions.

Serial Peripheral Interface (SPI)

Synchronous serial communication is provided with the SPI block. The Z32F384 MCU has 2-channel SPI modules. It includes a DMA function supported by the DMA controller. Transfer data is moved to/from the memory area without CPU operation. Boot mode uses this SPI block to download the Flash program.

Inter-Integrated Circuit Interface (I²C)

The Z32F384 MCU has a 2-channel I²C block and it supports up to 400 KHz I²C communication. Master and slave modes are supported.

Universal Asynchronous Receiver/Transmitter (UART)

The Z32F384 MCU has a 4-channel UART block. For accurate baud rate control, the fractional baud rate generator is provided. It includes a DMA function supported by the DMA controller. Transfer data is moved to/from the memory area without CPU operation.

General PORT I/Os

16-bit PA, PB, PC, PD, PE ports and 6-bit PF are available and provide multiple functionality:

- General I/O port
- Independent bit set/clear function
- External interrupt input port
- Pull-up/open-drain
- On chip debounce filter

12-bit Analog-to-Digital Converter (ADC)

2 built-in ADCs can convert analog signals up to 1usec conversion rate. A 16-channel analog mux provides various combinations from external analog signals.

Pin Description

The pin configurations are shown in Table 1.1. 16 pins are reserved for power/ground pair and dedicated pins.

Table 1.1. Pin Description

Pin No	Pin Name	Type	Description	Remark
1	GND	P	Ground	
2	PD2	IOUS	PORT D Bit 2 Input/Output	
	MOSI1	I/O	SPI Channel 1 Master Out / Slave In	
3	PD3*	IOUS	PORT D Bit 3 Input/Output	
	MISO1	I/O	SPI Channel 1 Master In / Slave Out	
4	PE0	IOUS	PORT E Bit 0 input/Output	
	TXD1	Output	UART Channel 1 TXD output	2nd function
5	PE1	IOUS	PORT E Bit 1 input/Output	
	RXD1	Input	UART Channel 1 RXD input	2nd function
6	PE2	IOUS	PORT E Bit 2 input/Output	
	T4I	I/O	Timer 4 Input	2nd function
	T3O	I/O	Timer 3 Output	2nd function
7	PF2	IOUS	PORT F Bit 2 input/Output	
	AN20	IA	Analog Input 20	
8	PF3	IOUS	PORT F Bit 3 input/Output	
	AN21	IA	Analog Input 21	
9	PA0*	IOUS	PORT A Bit 0 Input/Output	
	AN0	IA	Analog Input 0	
10	PA1*	IOUS	PORT A Bit 1 Input/Output	
	AN1	IA	Analog Input 1	
11	PA2*	IOUS	PORT A Bit 2 Input/Output	
	AN2	IA	Analog Input 2	
12	PA3*	IOUS	PORT A Bit 3 Input/Output	
	AN3	IA	Analog Input 3	
	PA4*	IOUS	PORT A Bit 4 Input/Output	
13	T0IO	IO	Timer 0 Input/Output	3rd function
	AN4	IA	Analog Input 4	
14	PA5*	IOUS	PORT A Bit 5 Input/Output	
	T1IO	IO	Timer 1 Input/Output	3rd function
	AN5	IA	Analog Input 5	
15	PA6*	IOUS	PORT A Bit 6 Input/Output	
	T2IO	IO	Timer 2 Input/Output	3rd function
	AN6	IA	Analog Input 6	
16	PA7*	IOUS	PORT A Bit 7 Input/Output	
	T3IO	IO	Timer 3 Input/Output	3rd function
	AN7	IA	Analog Input 7	
17	AGND	P	Analog Ground	
18	AVDD	P	Analog VDD	
19	PA8*	IOUS	PORT A Bit 8 Input/Output	
	AN8	IA	Analog Input 8	
20	PA9*	IOUS	PORT A Bit 9 Input/Output	
	AN9	IA	Analog Input 9	

21	PA10*	IOUS	PORT A Bit 10 Input/Output	
	AN10	IA	Analog Input 10	
22	PA11*	IOUS	PORT A Bit 10 Input/Output	
	AN11	IA	Analog Input 11	
23	PA12*	IOUS	PORT A Bit 12 Input/Output	
	SS0	I/O	SPI Channel 0 Slave Select signal	
	AN12	IA	Analog Input 12	
24	PD4	IOUS	PORT D Bit 4 Input/Output	
	SCL1	Output	I2C Channel 1 SCL In/Out	Open-drain
	AN16	IA	Analog Input 16	
25	PD5	IOUS	PORT D Bit 5 Input/Output	
	SDA1	Output	I2C Channel 1 SDA In/Out	Open-drain
	AN17	IA	Analog Input 17	
26	GND	P	Ground	
27	VDD	P	VDD	
28	PD6*	IOUS	PORT D Bit 6 Input/Output	
	TXD2	Output	UART Channel 2 TxD Output	
	AN18	IA	Analog Input 18	
29	PD7*	IOUS	PORT D Bit 7 Input/Output	
	RXD2	Input	UART Channel 2 RxD Input	
	AN19	IA	Analog Input 19	
30	PA13*	IOUS	PORT A Bit 13 Input/Output	
	SCK0	I/O	SPI Channel 0 Clock Input/Output	
	AN13	IA	Analog Input 13	
31	PA14*	IOUS	PORT A Bit 14 Input/Output	
	MOSI0	I/O	SPI Channel 0 Output(M)/Input(S) Data signal	
	AN14	IA	Analog Input 14	
32	PA15*	IOUS	PORT A Bit 15 Input/Output	
	MISO0	I/O	SPI Channel 0 Input(M)/Output(S) Data signal	
	AN15	IA	Analog Input 15	
33	PB0	IOUS	PORT B Bit 0 Input/Output	
	MP0UH	Output	PWM0 UH Output	
34	PB1	IOUS	PORT B Bit 1 Input/Output	
	MP0UL	Output	PWM0 UL Output	
35	PB2	IOUS	PORT B Bit 0 Input/Output	
	MP0VH	Output	PWM0 VH Output	
36	PB3	IOUS	PORT B Bit 1 Input/Output	
	MP0VL	Output	PWM0 VL Output	
37	PF4	IOUS	PORT F Bit 4 Input/Output	
38	PF5	IOUS	PORT F Bit 5 Input/Output	
39	PE3	IOUS	PORT E Bit 3 Input/Output	
	SCL0	Output	I2C Channel 0 SCL In/Out	Open-drain 2nd function
	PE4	IOUS	PORT E Bit 4 Input/Output	
40	SDA0	Output	I2C Channel 0 SDA In/Out	Open-drain 2nd function
	PE5	IOUS	PORT E Bit 5 Input/Output	
41	T5IO	I/O	Timer 5 Input/Output	
42	TEST	Input	Test-mode Input (Always 'L')	Pull-down
43	SCANMD	Input	Scan-mode Input (Always 'L')	Pull-down

44	PB4	IOUS	PORT B Bit 4 Input/Output	
	MP0WH	Output	PWM0 WH Output	
	T9IO	I/O	Timer 9 Input/Output	
45	PB5	IOUS	PORT B Bit 5 Input/Output	
	MP0WL	Output	PWM0 WL Output	
	T9IO	I/O	Timer 9 Input/Output	2nd function
46	PB6	IOUS	PORT B Bit 6 Input/Output	
	PRTIN0	Input	PWM0 Protection Input signal 0	
	WDTO	Output	WDT Output	
47	PB7	IOUS	PORT B Bit 7 Input/Output	
	OVIN0	Input	PWM0 Over-Current Input signal 1	
	STBY0	Output	Power-down mode indication signal	
48	PB8	IOUS	PORT B Bit 8 Input/Output	
	PRTIN1	Input	PWM1 Protection Input signal 0	
	RXD3	Output	UART Channel 3 RXD Input	
49	PD8	IOUS	PORT D Bit 8 Input/Output	
	WDTO	Output	WDT Output	2nd function
	T6IO	I/O	Timer 6 Input/Output	
50	PD9	IOUS	PORT D Bit 9 Input/Output	
	STBY0	Output	Power-down mode indication signal	2nd function
	T7IO	I/O	Timer 7 Input/Output	
51	GND	P	Ground	
52	VDD	P	VDD	
53	PB9	IOUS	PORT B Bit 9 Input/Output	
	OVIN1	Input	PWM1 Over-Current Input signal 1	
	TXD3	Output	UART Channel 3 TXD Output	
54	PB10	IOUS	PORT B Bit 10 Input/Output	
	MP1UH	Output	PWM Channel 1 UH Output	
55	PB11	IOUS	PORT B Bit 11 Input/Output	
	MP1UL	Output	PWM Channel 1 UL Output	
56	PB12	IOUS	PORT B Bit 12 Input/Output	
	MP1VH	Output	PWM Channel 1 VH Output	
57	PB13	IOUS	PORT B Bit 13 Input/Output	
	MP1VL	Output	PWM Channel 1 VL Output	
58	PB14	IOUS	PORT B Bit 14 Input/Output	
	MP1WH	Output	PWM Channel 1 WH Output	
59	PB15	IOUS	PORT B Bit 15 Input/Output	
	MP1WL	Output	PWM Channel 1 WL Output	
60	PF0	IOUS	PORT F Bit 0 Input/Output	
61	PF1	IOUS	PORT F Bit 1 Input/Output	
62	PC0	IOUS	PORT C Bit 0 Input/Output	
	TCK/SWCLK	Input	JTAG TCK, SWD Clock Input	
	RXD0	Input	UART Channel 0 RXD Input	2nd function
63	PC1	IOUS	PORT C Bit 1 Input/Output	
	TMS/SWDIO	I/O	JTAG TMS, SWD Data Input/Output	
	TXD0	Input	UART Channel 0 TXD Output	2nd function
64	PE6	IOUS	PORT E Bit 6 Input/Output	
	T5IO	I/O	Timer 5 Input/Output	2nd function
65	PE7	IOUS	PORT E Bit 7 Input/Output	

	T6IO	I/O	Timer 6 Input/Output	2nd function
66	PE8	IOUS	PORT E Bit 8 Input/Output	
	T7IO	I/O	Timer 7 Input/Output	2nd function
67	PE9	IOUS	PORT E Bit 9 Input/Output	
	T8IO	I/O	Timer 8 Input/Output	3rd function
68	PE10	IOUS	PORT E Bit 10 Input/Output	
	T9IO	I/O	Timer 9 Input/Output	3rd function
69	PD10	IOUS	PORT D Bit 10 Input/Output	
	AD0SOC	Output	ADC0 Start-of-Conversion	
	TOIO	IO	Timer 0 Input/Output	3rd function
70	PD11	IOUS	PORT D Bit 10 Input/Output	
	AD0EOC	Output	ADC0 End-of-Conversion	
	T1IO	IO	Timer 1 Input/Output	3rd function
71	NMI	Input	Non-maskable Interrupt Input	
	PD12	IOUS	PORT D Bit 12 Input/Output	
72	AD1SOC	Output	ADC1 Start-of-Conversion	
	T2IO	IO	Timer 2 Input/Output	3rd function
	PD13	IOUS	PORT D Bit 13 Input/Output	
73	AD1EOC	Output	ADC1 End-of-Conversion	
	T3IO	IO	Timer 3 Input/Output	3rd function
	PC2	IOUS	PORT C Bit 2 Input/Output	
74	TDO/SWO	Output	JTAG TDO, SWO Output	
	PC3	IOUS	PORT C Bit 3 Input/Output	
75	TDI	Input	JTAG TDI Input	
	GND	P	Ground	
76	VDD	P	VDD	
	PC4	IOUS	PORT C Bit 4 Input/Output	
78	nTRST	Input	JTAG nTRST Input	
	TOIO	IO	Timer 0 Input/Output	2nd function
	PC5	IOUS	PORT C Bit 5 Input/Output	
79	RXD1	Input	UART Channel 1 RXD Input	
	T1IO	IO	Timer 1 Input/Output	2nd function
	PC6	IOUS	PORT C Bit 6 Input/Output	
80	TXD1	Output	UART Channel 1 TXD Output	
	T2IO	IO	Timer 2 Input/Output	2nd function
	PC7	IOUS	PORT C Bit 7 Input/Output	
81	SCL0	IO	I2C Channel 0 SCL In/Out	
	T3IO	IO	Timer 3 Input/Output	2nd function
	PC8	IOUS	PORT C Bit 8 Input/Output	
82	SDA0	IO	I2C Channel 0 SDA In/Out	
	T4IO	IO	Timer 4 Input/Output	
	PC9	IOUS	PORT C Bit 9 Input/Output	
83	CLK0	Output	System Clock Output	
	T8IO	IO	Timer 8 Input/Output	
	PC10	IOUS	PORT C Bit 10 Input/Output	
84	nRESET	Input	External Reset Input	Pull-up
	PC11	IOUS	PORT C Bit 11 Input/Output	
85	BOOT	Input	Boot mode Selection Input	
	T8IO	Input	Timer 8 Input/Output	2nd function
86	PE11	IOUS	PORT E Bit 11 Input/Output	
	TOIO	IO	Timer 0 Input/Output/Phase-A Input	4st function

	SCL1	IO	I2C Channel 1 SCL Input/Output	2nd function
	PE12	IOUS	PORT E Bit 12 Input/Output	
87	T1I0	IO	Timer 1 Input/Output/Phase-B Input	4st function
	SDA1	IO	I2C Channel 1 SDA input/Output	2nd function
	PE13	IOUS	PORT E Bit 13 Input/Output	
88	T2I0	IO	Timer 2 Input/Output/Phase-Z Input	4st function
	TXD2	Output	UART Channel 2 TXD Output	2nd function
	PE14	IOUS	PORT E Bit 14 Input/Output	
89	T3I0	IO	Timer 3 Input/Output	4st function
	RXD2	Input	UART Channel 2 RXD Input	2nd function
90	PE15	IOUS	PORT E Bit 15 Input/Output	
	T4I0	IO	Timer 4 Input/Output	2nd function
91	PD14	IOUS	PORT D Bit 14 Input/Output	
	SS0	IO	SPI Channel 0 Slave Select signal	2nd function
92	PD15	IOUS	PORT D Bit 15 Input/Output	
	SCK0	IO	SPI Channel 0 Clock Input/Output	2nd function
	PC15	IOUS	PORT C Bit 14 Input/Output	
93	TXD0	Output	UART Channel 0 TXD Output	
	MISO0	I/O	SPI Channel 0 Input(M)/Output(S)	2nd function
	PC14	IOUS	PORT C Bit 14 Input/Output	
94	RXD0	Input	UART0 RXD Input	
	MOSI0	I/O	SPI Channel 0 Output(M)/Input(S)	2nd function
	VMARGIN	OA	Not used. (test purpose)	
95	PC13	IOUS	PORT C Bit 13 Input/Output	
	XOUT	OA	External Crystal Oscillator Output	
96	PC12	IOUS	PORT C Bit 12 Input/Output	
	XIN	IA	External Crystal Oscillator Input	
	PD0	IOUS	PORT D Bit 0 Input/Output	
97	SS1	I/O	SPI Channel 1 Slave Select signal	
	SXIN	IA	Sub Crystal Oscillator Input	
	PD1	IOUS	PORT D Bit 1 Input/Output	
98	SCK1	I/O	SPI Channel 1 Clock Input/Output	
	SXOUT	OA	Sub Crystal Oscillator Output	
99	VDD	P	VDD	
100	GND	P	Ground	

*Notation: I=Input, O=Output, U=Pull-up, D=Pull-down,
 S=Schmitt-Trigger Input Type, C=CMOS Input Type, A=Analog, P=Power
 (*) Selected pin function after reset condition
 Pin order may be changed with revision notice

Memory Map

Memory map	
Address	
0x0000_0000	Code Flash ROM (384KB)
0x0005_FFFF	
0x0006_0000	Reserved
0x1FFE_FFFF	Boot ROM (2KB)
0x1FFF_0000	
0x1FFF_07FF	Reserved
0x1FFF_0800	
0x1FFF_FFFF	SRAM (16K)
0x2000_0000	
0x2000_5FFF	Reserved
0x2000_6000	
0x2FFF_FFFF	SRAM Bit-banding region
0x2200_0000	
0x23FF_FFFF	Reserved
0x2400_0000	
0x2FFF_FFFF	Code Flash ROM (Mirrored) (384KB)
0x3000_0000	
0x3005_FFFF	Boot ROM (Mirrored) (2KB)
0x3008_0000	
0x3008_07FF	OTP ROM (Mirrored)
0x3009_0000	
0x3009_01FF	Reserved
0x3009_0200	
0x3FFF_FFFF	Peripherals
0x4000_0000	
0x4000_FFFF	Reserved
0x4001_0000	
0x41FF_FFFF	Peripherals bit-banding region
0x4200_0000	
0x43FF_FFFF	Reserved
0x4400_0000	
0x5FFF_FFFF	External Memory (Not supported)
0x6000_0000	
0x9FFF_FFFF	External Device (Not supported)
0xA000_0000	
0xDFFF_FFFF	Private peripheral bus: Internal
0xE000_0000	
0xE003_FFFF	Private peripheral bus: Debug/External
0xE004_0000	
0xE00F_FFFF	Vendor Specific
0xE010_0000	
0xFFFF_FFFF	

Figure1.4. Main Memory Map

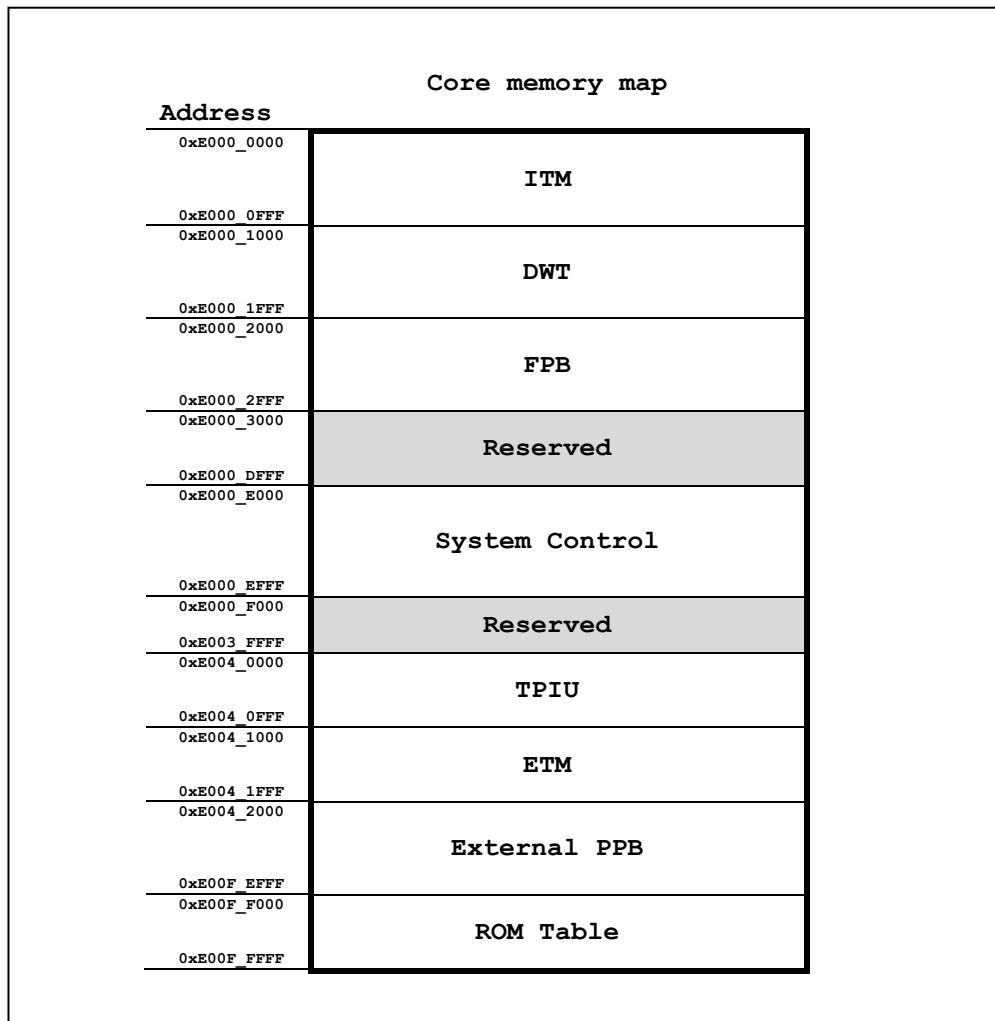

Figure1.5. Cortex-M3 Private Memory Map

Note: Please see document number DDI337 from ARM for more information about the Cortex-M3 memory map.

Address	Peripheral map
0x4000_0000	SCU
0x4000_0100	FMC
0x4000_0200	WDT
0x4000_0300	Reserved
0x4000_0400	DMAC (8)
0x4000_0500	Reserved
0x4000_0600	FRT
0x4000_1000	PCU
0x4000_2000	GPIO (A, B, C, D, E, F)
0x4000_3000	TIMER
0x4000_4000	MPWM0
0x4000_5000	MPWM1
0x4000_6000	Reserved
0x4000_8000	UART0
0x4000_8100	UART1
0x4000_8200	UART2
0x4000_8300	UART3
0x4000_8600	Reserved
0x4000_9000	SPI0
0x4000_9100	SPI1
0x4000_9200	Reserved
0x4000_A000	I ² C0
0x4000_A100	I ² C1
0x4000_A200	Reserved
0x4000_B000	ADC0
0x4000_B100	ADC1
0x4000_B200	Reserved
0x4000_B300	Reserved
0x4000_B400	Reserved
0x4000_FFFF	Reserved

Figure1.6. Peripheral Memory Map

2. CPU

Cortex-M3 Core

The CPU core is supported from the ARM Cortex-M3 processor which provides a high-performance, low-cost platform.

Document DDI337 from ARM provides more information about the Cortex-M3.

System Timer

The System Timer (SYSTICK) is a 24-bit timer and is part of the Cortex-M3 core. The system timer can be configured either through the registers (see the Cortex-M3 Technical Reference Manual) or through the provided functions defined in `core_cm3.h`. There is an interrupt vector for the system timer. To configure the system timer, call `SysTickConfig()` with the number of system clocks in between Interrupt intervals (up to maximum of 24 bits).

Interrupt Controller

The Nested Vectored Interrupt Controller is part of the core Cortex-M3 MCU. The NVIC controls the system exceptions and peripheral interrupts and is closely coupled with the core to provide low latency and efficient processing of late arriving interrupts. The NVIC maintains knowledge of the nested interrupts to enable tail-chaining of interrupts.

The Z32F128 MCU supports 64 peripheral interrupts (although 25 are not used) and 16 system interrupts. The NVIC also allows for setting software interrupts as well as resetting the system.

Interrupts can be assigned a Priority Group (common interrupts with the same priorities) as well as individual priorities. Eight priority levels are available. For an interrupt to be active, you must enable it in the peripheral and the NVIC registers. For more information on NVIC, see the Cortex M3 Technical Reference Manual.

The system includes functions to set the NVIC registers, which are defined in the `core_cm3.h`.

Table2.1. Interrupt Vector Map

Priority	Vector Address	Interrupt Source
-16	0x0000_0000	Stack Pointer
-15	0x0000_0004	Reset Address
-14	0x0000_0008	NMI Handler
-13	0x0000_000C	Hard Fault Handler
-12	0x0000_0010	MPU Fault Handler
-11	0x0000_0014	BUS Fault Handler
-10	0x0000_0018	Usage Fault Handler
-9	0x0000_001C	Reserved
-8	0x0000_0020	Reserved
-7	0x0000_0024	Reserved
-6	0x0000_0028	Reserved
-5	0x0000_002C	SVCALL Handler
-4	0x0000_0030	Debug Monitor Handler
-3	0x0000_0034	Reserved
-2	0x0000_0038	PenSV Handler
-1	0x0000_003C	SysTick Handler
0	0x0000_0040	LVDDETECT
1	0x0000_0044	SYSClkFAIL
2	0x0000_0048	XOSCFail
3	0x0000_004C	WDT
4	0x0000_0050	FRT
5	0x0000_0054	TIMER0
6	0x0000_0058	TIMER1
7	0x0000_005C	TIMER2
8	0x0000_0060	TIMER3
9	0x0000_0064	TIMER4
10	0x0000_0068	TIMER5
11	0x0000_006C	TIMER6
12	0x0000_0070	TIMER7
13	0x0000_0074	TIMER8
14	0x0000_0078	TIMER9
15	0x0000_007C	Reserved
16	0x0000_0080	GPIOAE
17	0x0000_0084	GPIOAO
18	0x0000_0088	GPIOBE
19	0x0000_008C	GPIOBO
20	0x0000_0090	GPIOCE
21	0x0000_0094	GPIOCO
22	0x0000_0098	GPIODE
23	0x0000_009C	PIODO
24	0x0000_00A0	MPWM0
25	0x0000_00A4	MPWM0PROT

26	0x0000_00A8	MPWM0OVV
27	0x0000_00AC	MPWM1
28	0x0000_00B0	MPWM1PROT
29	0x0000_00B4	MPWM1OVV
30	0x0000_00B8	Reserved
31	0x0000_00BC	Reserved
32	0x0000_00C0	SPI0
33	0x0000_00C4	SPI1
34	0x0000_00C8	Reserved
35	0x0000_00CC	Reserved
36	0x0000_00D0	I2C0
37	0x0000_00D4	I2C1
38	0x0000_00D8	UART0
39	0x0000_00DC	UART1
40	0x0000_00E0	UART2
41	0x0000_00E4	UART3
42	0x0000_00E8	Reserved
43	0x0000_00EC	ADC0
44	0x0000_00F0	ADC1
45	0x0000_00F4	Reserved
46	0x0000_00F8	Reserved
47	0x0000_00FC	Reserved
48	0x0000_0100	Reserved
49	0x0000_0104	Reserved
50	0x0000_0108	GPIOEE
51	0x0000_010C	GPIOEO
52	0x0000_0110	GPIOFE
53	0x0000_0114	GPIOFO
54	0x0000_0118	Reserved
55	0x0000_011C	Reserved
56	0x0000_0120	Reserved
57	0x0000_0124	Reserved
58	0x0000_0128	Reserved
59	0x0000_012C	Reserved
60	0x0000_0130	Reserved
61	0x0000_0134	Reserved
62	0x0000_0138	Reserved
63	0x0000_013C	Reserved

3. Boot Mode

Boot Mode Pins

The Z32F384 MCU has a boot mode option to program internal Flash memory. When the BOOT pin is pulled low, the system starts up in the BOOT area (0x1FFF_0000) instead of the default Flash area (0x0000_0000). This provides the ability to flash the part using either UART or SPI interfaces. The BOOT pin has an internal pull up resistor; therefore, when the BOOT pin is not connected, it rides high (normal state).

The boot mode uses the UART0 port and the SPI0 ports for the interface. JTAG and SW interfaces can also be used, which provides the ability to recover from a bad flash update that prevents the JTAG or SW debugger from attaching.

The pins for boot mode are listed in Table 3.1.

Table3.1. Boot Mode Pin List

Block	Pin Name	Dir	Description
SYSTEM	nRESET/PC10	I	Reset Input signal
	BOOT/PC11	I	'0' to enter Boot mode
UART0	RXD0/PC14	I	UART Boot Receive Data
	TXD0/PC15	O	UART Boot Transmit Data
SPI0	SS0/PA12	I	SPI Boot Slave Select
	SCK0/PA13	I	SPI Boot Clock Input
	MOSI0/PA14	I	SPI Boot Data Input
	MISO0/PA15	O	SPI Boot Data Output

Boot Mode Connections

Users can design the target board using either of the boot mode ports – UART or SPI.

Figures 3.1 and 3.2 show sample boot mode connection diagrams.

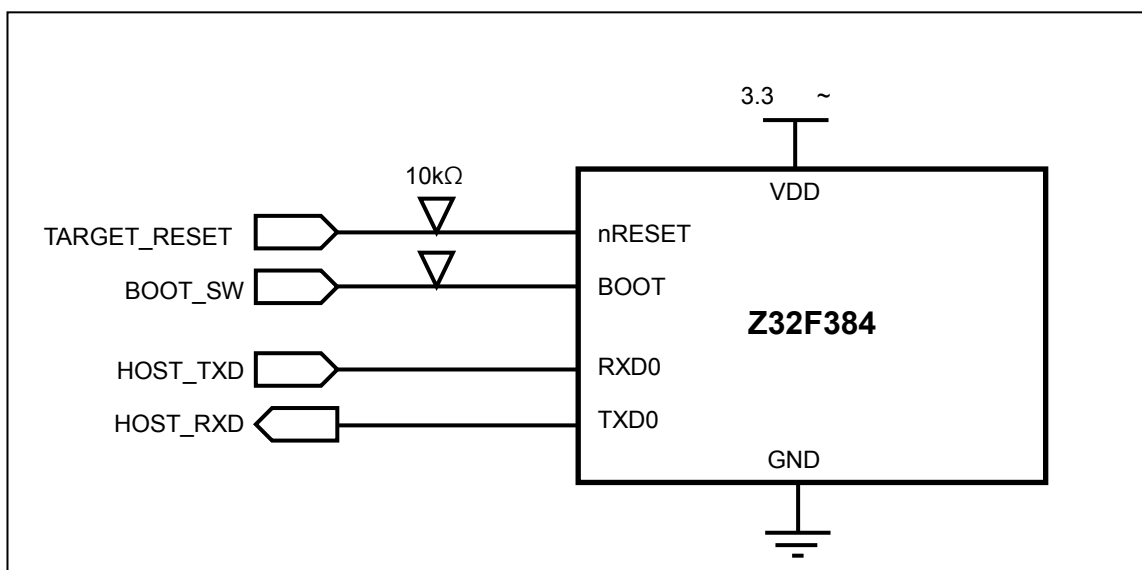

Figure3.1. UART Boot Connection Diagram

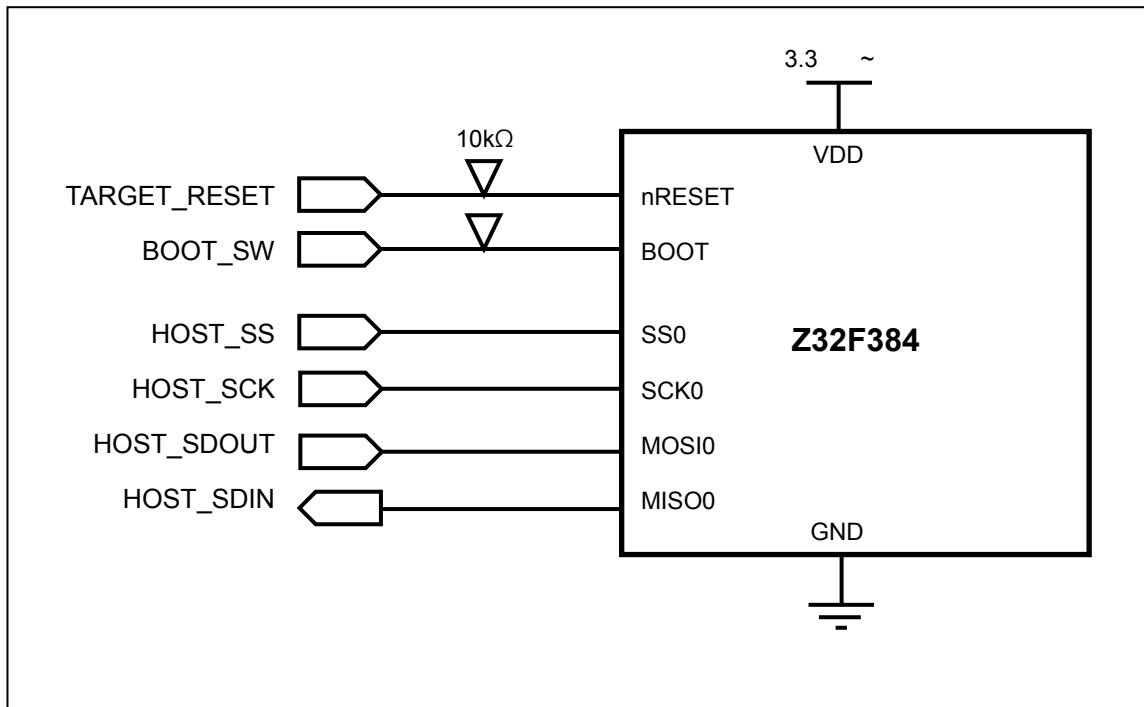

Figure3.2. SPI Boot Connection Diagram

4. System Control Unit

Overview

The Z32F384 MCU has a built-in intelligent power control block which manages system analog blocks and operating modes. Internal reset and clock signals are controlled by SCU block to maintain optimize system performance and power dissipation.

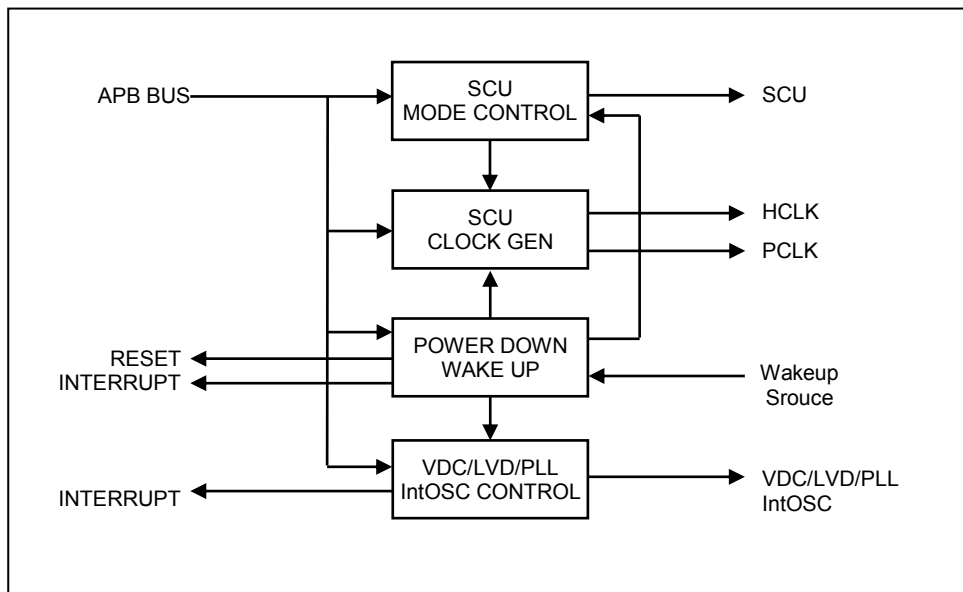

Figure 4.1. SCU Block Diagram

Clock System

The Z32F384 MCU has two main clock systems. One is MCLK which supplies the clock to the HCLK_Free, CPU and AHB bus system. The PCLK clock is for the Peripheral clock and is supplied from MCLK. Some peripherals have the option to derive their clock from other clocks or the PCLK. User can control the clock system variation by software. Figure 4.2 shows the clock system of the chip, Table 4.1 lists the clock source descriptions.

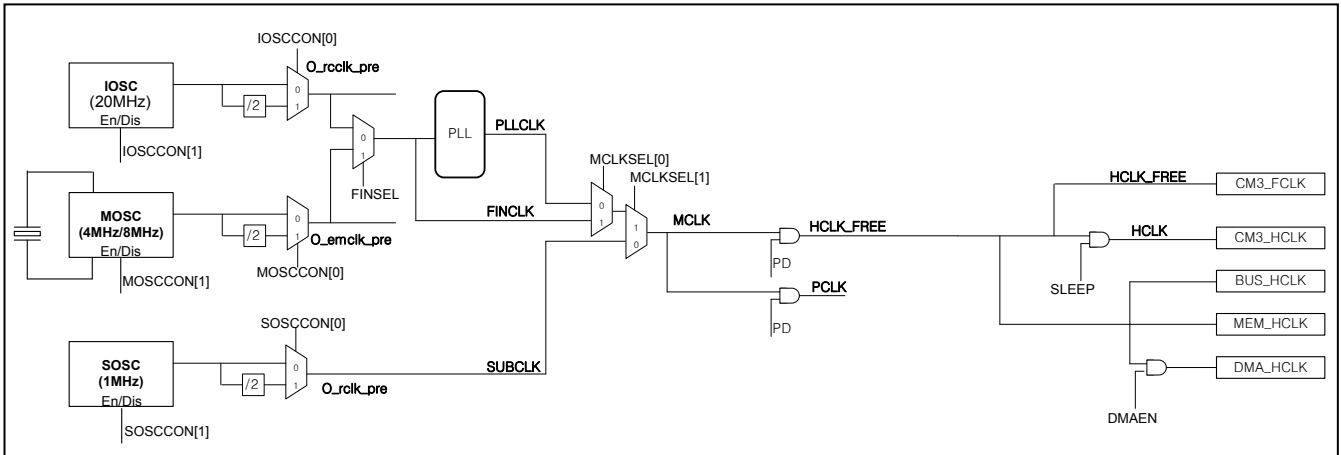

Figure 4.2. System Clock Configuration

Each of the mux to switch clock sources has a glitch-free circuit; therefore, the clock can be switched without a risk of glitches.

Table 4.1. Clock Sources

Clock name	Frequency	Description
IOOSC20	20MHz	Internal OSC
Sub OSC	Sub X-TAL (32.768KHz)	Sub External Crystal OSC
MainOSC	X-TAL(4MHz~16MHz)	External Crystal OSC
PLL Clock	8MHz ~ 80MHz	On Chip PLL
ROSC	1MHz	Internal RING OSC

The PLL can synthesize the PLLCLK clock up to 80 MHz with either the Internal Oscillator or the External Crystal Oscillator reference clocks. It also has an internal pre-divider and post-divider.

HCLK Clock Domain

The HCLK clock feeds the clock to the CPU and AHB bus. The Cortex-M3 CPU requires two clocks related to the HCLK clock, FCLK and HCLK. FCLK is a free running clock and is always running except in power down mode. HCLK can be stopped in idle mode.

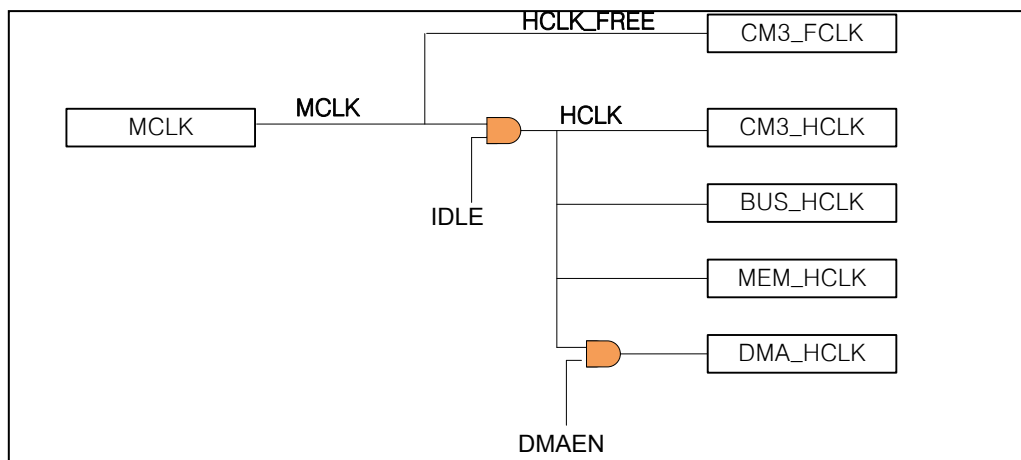

Figure 4.3. System Clock Configuration

Miscellaneous Clock Domain for Cortex-M3

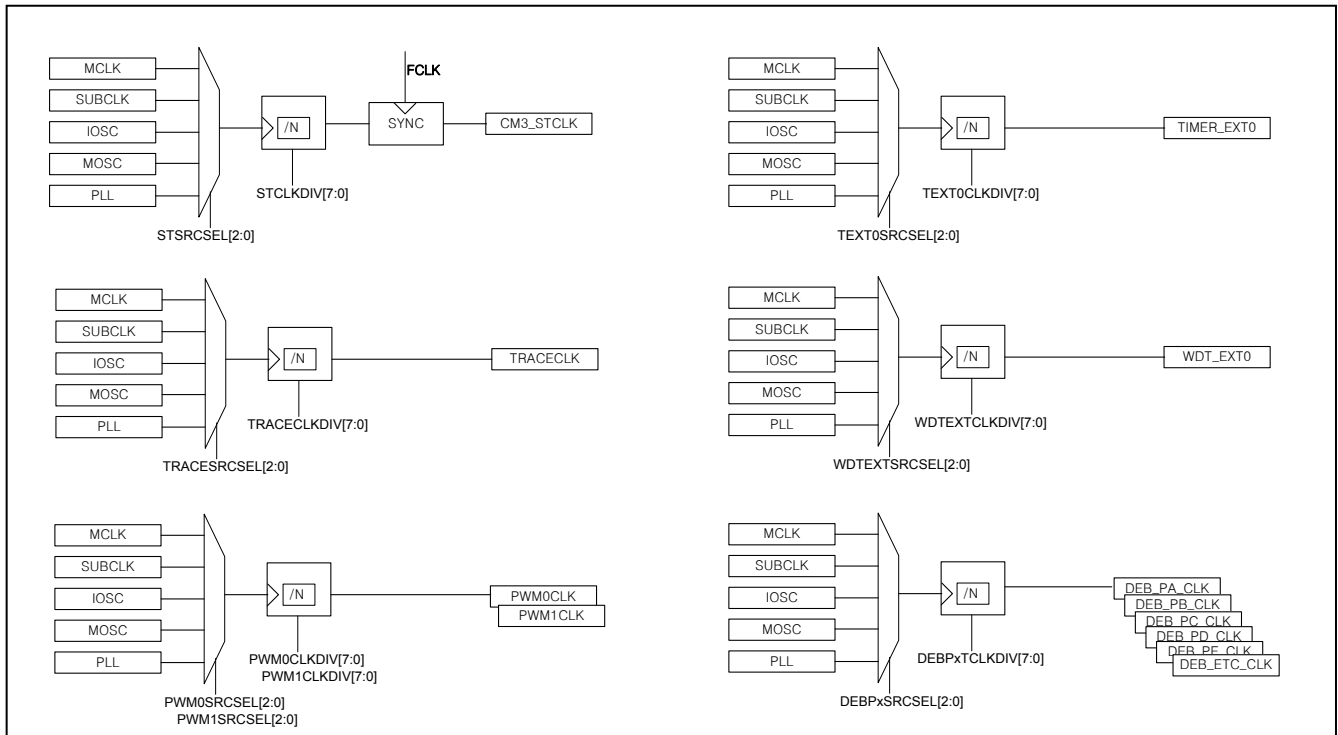

Figure 4.4. Miscellaneous Clock Configuration

PCLK Clock Domain

PCLK is the master clock of all the peripherals. It can be stopped in power down mode. Each peripheral clock is generated by the PCER register set.

Clock Configuration Procedure

After power up, the default system clock is fed by the RINGOSC (1 MHz) clock. RINGOSC is enabled by default during the power up sequence. The other clock sources are enabled by user controls with the RINGOSC system clock.

The MOSC clock can be enabled by the CSCR register. Prior to enabling the MOSC block, the pin mux configuration should be set for the XIN, XOUT function. PC12 and PC13 pins are shared with the MOSC's XIN and XOUT function; the PCCMR and PCCCR registers should be correctly configured. After enabling the MOSC block, you must wait for more than 1 msec to ensure stable crystal oscillation operation.

The PLL clock can be enabled by the PLLCON register. After enabling the PLL block, you must wait for the PLL lock, before you can select the PLL clock as the MCLK. Before changing the system clock, Flash access wait should be set to the maximum value. After the system clock is changed, you can set the desired Flash access wait value.

Figure 4.5 shows a sample flow chart for configuring the system clock.

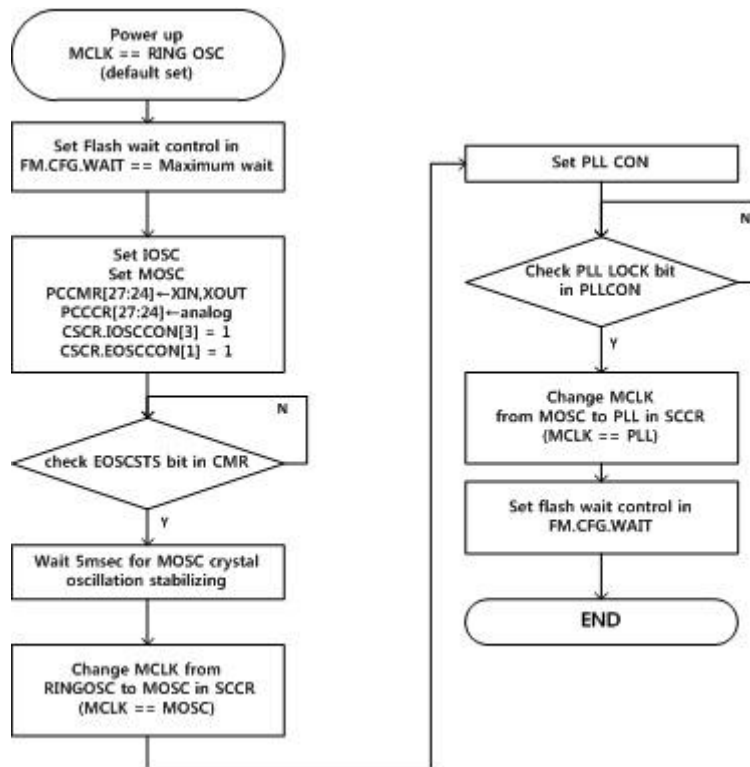

Figure 4.5 Clock Configuration Flow Chart

When you speed up the system clock to the maximum operating frequency, check the Flash wait control configuration. Flash read access time is a limiting factor for optimum performance. The wait control recommendation is provided in Table 4.1.

Table 4.1. Flash Wait Control Recommendation

FM.CFG.WAIT	Flash Access Wait	Available Max System Clock Frequency
000	0 wait	~25MHz
001	1 wait	~50MHz
010	2 wait	~75MHz
011	3 wait	~75MHz
100	4 wait	~75MHz
101	5 wait	~75MHz

Cold Reset

Cold reset is an important feature of the chip when power is up. This characteristic globally affects the system boot. Internal VDC is enabled when VDD power is turned on. The internal VDD level slope is followed by the external VDD power slope. The internal PoR trigger level is 1.4 V of internal VDC voltage out level. At this time, boot operation is started. The RINGOSC clock is enabled and counts to 4 msec for internal VDC level stabilizing. During this time, the external VDD voltage level should be greater than the initial LVD level (2.3 V). After waiting 4 msec, the CPU reset is released and the operation is started.

Figure 4.6 shows the power up sequence and internal reset waveform.

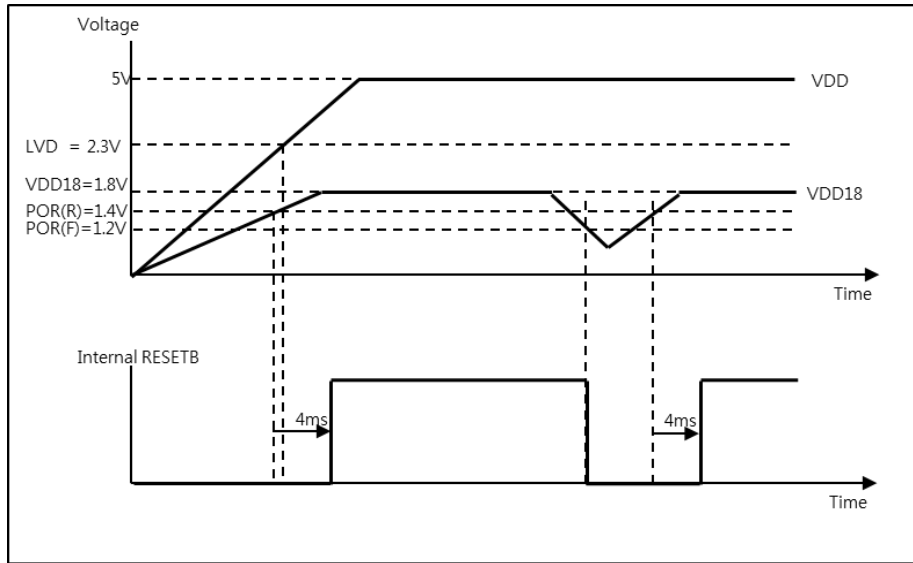

Figure 4.6. Power Up POR Sequence

The RSSR register shows the POR reset status. The last reset comes from POR; RSSR.PORST is set to “1”. After power up, this bit is always “1”. If an abnormal internal voltage drop occurs during normal operation, the system will be reset and this bit is also set to “1”.

When cold reset is applied, the chip returns to its initial state.

Warm Reset

The warm reset event has several reset sources. Some parts of the chip return to initial state when a warm reset condition occurs.

The warm reset source is controlled by the RSER register and the status appears in the RSSR register. The reset for each peripheral block is controlled by the PRER register. The reset can be masked independently.

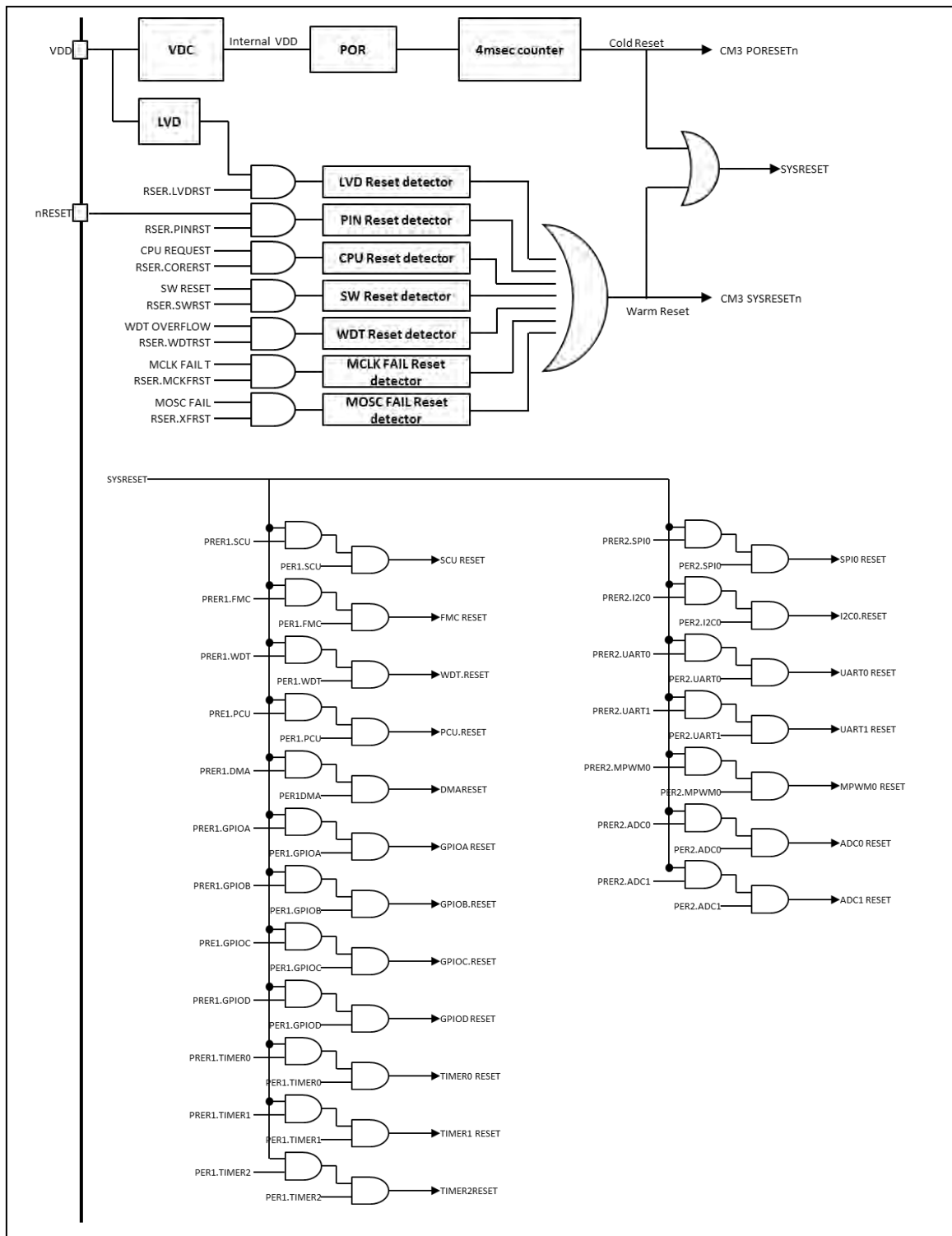

Figure 4.7. Warm Reset

The CM3_SYSRESETn signal resets the processor, excluding debug logic in the processor.

Operation Mode

The INIT mode is the initial state of the chip when reset is asserted. The RUN mode is for maximum performance of the CPU with a high-speed clock system. The SLEEP and POWER DOWN modes can be used as low- power consumption modes. Low-power consumption is achieved by halting the processor core and unused peripherals.

Figure 4.5 shows the operating mode transition diagram.

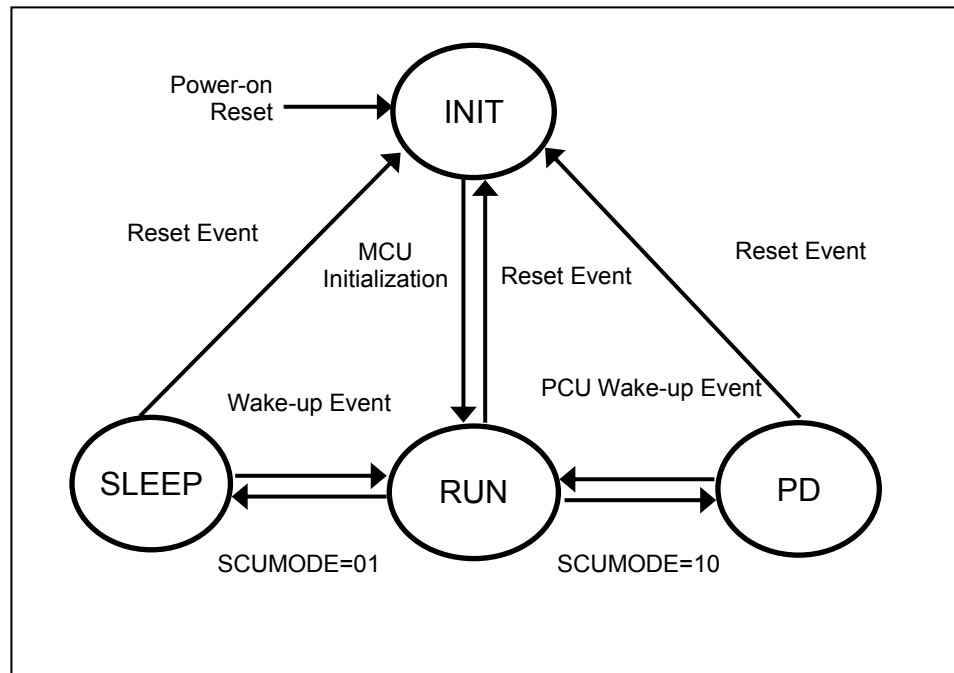

Figure4.5. Operating Mode

RUN Mode

In RUN mode, the CPU core and the peripheral hardware is operated by using the high-speed clock. After reset, followed by the INIT state, the chip enters RUN mode.

SLEEP Mode

In SLEEP mode, only the CPU is stopped. Each peripheral function can be enabled by the function enable and clock enable bit in the PER and PCER register.

POWER DOWN Mode

In POWER DOWN mode, all internal circuits enter the stop state. Power down operation has a special power off sequence, as shown in Figure 4.6.

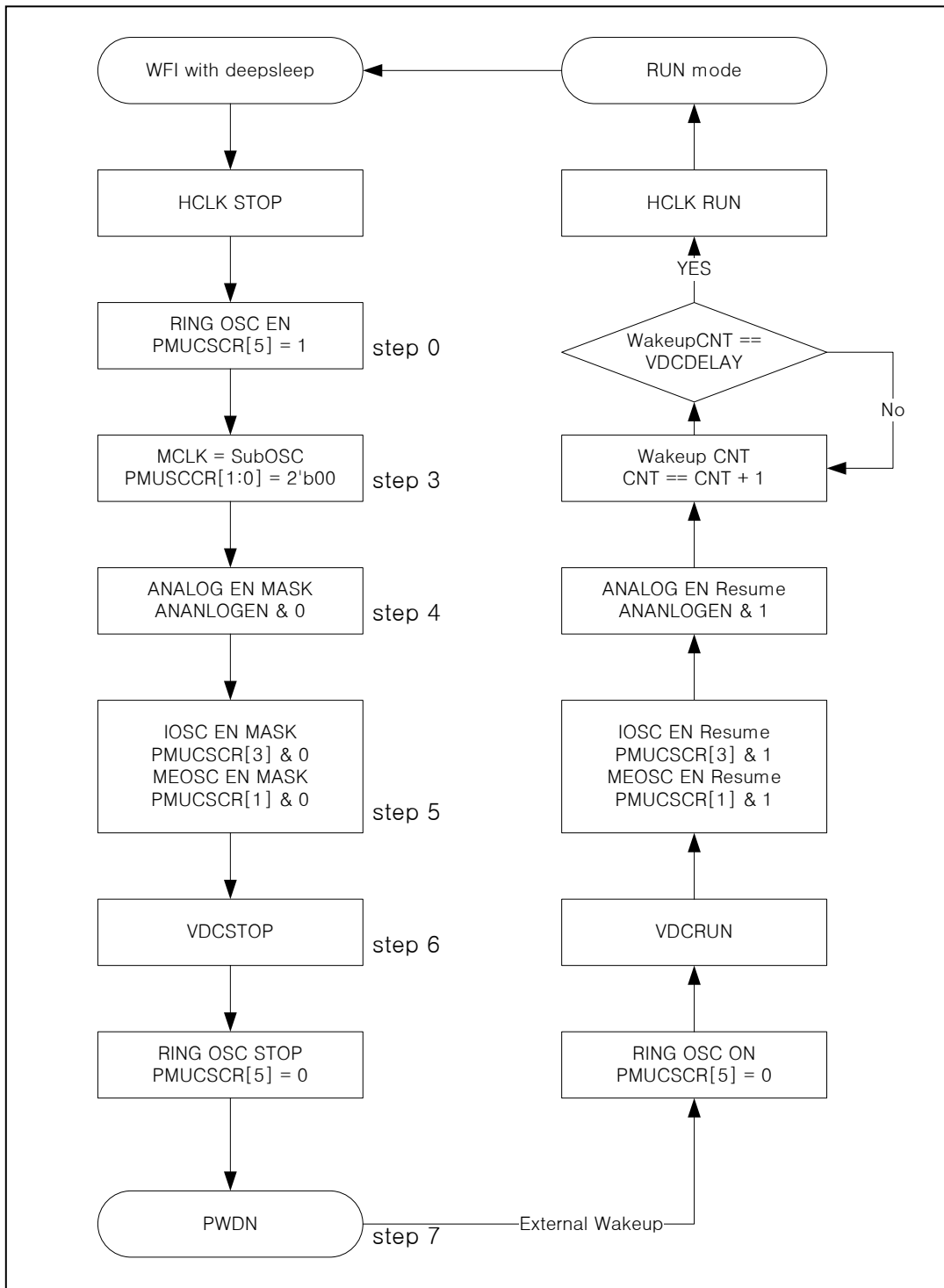

Figure 4.6. Power-down and Wake-up Procedure

Pin Description

Table4.2. SCU and PLL Pins

PIN NAME	TYPE	DESCRIPTION
nRESET	I	External Reset Input
XIN/XOUT	OSC	External Crystal Oscillator
SXIN/SXOUT	OSC	External Sub Crystal Oscillator
STBYO	O	Stand-by Output Signal
CLKO	O	Clock Output Monitoring Signal

Registers

The base address of SCU is 0x4000_0000 and the register map is described in Table.4.3

Table 4.3. SCU Register Map

Name	Offset	R/W	Description	Reset
CIDR	0x0000	R	CHIP ID Register	AC33_0384
SMR	0x0004	R/W	System Mode Register	0000_0000
SRCR	0x0008	R/W	System Reset Control Register	0000_0000
CIDR2	0x000C	R/W	CHIP Revision ID Register	0000_0000
WUER	0x0010	R/W	Wake up source enable register	0000_0000
WUSR	0x0014	R/W	Wake up source status register	0000_0000
RSER	0x0018	R/W	Reset source enable register	0000_0049
RSSR	0x001C	R/W	Reset source status register	0000_0080*
PRER1	0x0020	R/W	Peripheral reset enable register 1	03FF_1F1F*
PRER2	0x0024	R/W	Peripheral reset enable register 2	00F3_0F33*
PER1	0x0028	R/W	Peripheral enable register 1	0000_000F*
PER2	0x002C	R/W	Peripheral enable register 2	0000_0101*
PCER1	0x0030	R/W	Peripheral clock enable register 1	0000_000F*
PCER2	0x0034	R/W	Peripheral clock enable register 2	0000_0101*
CSCR	0x0040	R/W	Clock Source Control register	0000_0020
SCCR	0x0044	R/W	System Clock Control register	0000_0000
CMR	0x0048	R/W	Clock Monitoring register	0000_0003
NMIR	0x004C	R/W	NMI control register	0000_0000
COR	0x0050	R/W	Clock Output Control register	0000_000F
	0x0054	-	Reserved	
PLLCON	0x0060	R/W	PLL Control register	0000_1000
VDCCON	0x0064	R/W	VDC Control register	0000_000F
LVDCON	0x0068	R/W	LVD Control register	0000_0001
IOSCTRIM	0x006C	R/W	Internal RC OSC Control register	0000_0000
	0x0070	-	Reserved	0000_0000
	0x0074	-	Reserved	0000_0000
	0x0078	-	Reserved	0000_0000
	0x007C	-	Reserved	0000_0000
EOSCR	0x0080	R/W	External Oscillator control register	0000_0000
EMODR	0x0084	R/W	External mode pin read register	0000_000X
DBCLK1	0x009C	R/W	Debounce Clock for PA, PB Pins	0000_0000
DBCLK2	0x00A0	R/W	Debounce Clock for PC, PD Pins	0000_0000
DBCLK3	0x00A4	R/W	Debounce Clock for PE, PF pins	0000_0001
MCCR1	0x0090	R/W	Trace and SysClock Clock Control	0404_0001
MCCR2	0x0094	R/W	MPWM0 and MPWM1 Clock Control	0000_0000
MCCR3	0x0098	R/W	TEXT0 and WDT clock control	0000_0001
MCCR4	0x00A8	R/W	ADC and NMI Debounce Clock control	0000_0001

CIDR Chip ID Register

The Chip ID register shows chip identification information. This register is a 32-bit read-only register.

CIDR=0x4000_0000

31	30	29	28	27	26	25	24	23	22	21	20	19	18	17	16	15	14	13	12	11	10	9	8	7	6	5	4	3	2	1	0
CHIPID																															
AC33_0384																															
Read Only																															

31	CHIP ID	Device ID
0		AC33_0384

CIDR2=0x4000_000C

31	30	29	28	27	26	25	24	23	22	21	20	19	18	17	16	15	14	13	12	11	10	9	8	7	6	5	4	3	2	1	0
REVISION ID																															
0x0000_0002																															
Read Only																															

31	REVISION ID	Device Revision ID
0		0x0000_0002

SMR System Mode Register

The current operating mode is shown in this SCU mode register and the operation mode can be changed by writing new mode in this register. The previous operating mode is saved in this register after a reset event.

The System Mode register is a 16-bit register.

SMR=0x4000_0004

15	14	13	12	11	10	9	8	7	6	5	4	3	2	1	0
							VDCAON				PREVMODE				
0	0	0	0	0	0	0	0	0	0	00	0	0	0	0	0
R/W								R							

8	VDCAON	VDC Always on
	0	VDC will be off when Power down mode
	1	VDC always on even in power down mode
5	PREVMODE	Previous operating mode before current reset event.
4		00 Previous operating mode was RUN mode
		01 Previous operating mode was SLEEP mode
		10 Previous operating mode was PowerDown mode
		11 Previous operating mode was INIT mode

SRCR System Reset Control Register

The Ssystem Reset Control register is an 8-bit register.

SCR=0x4000_0008

7	6	5	4	3	2	1	0
			STBYOP				SWRST
0	0	0	0	0	0	0	0
			RW				W

5	STBYOP	STBYO pin output polarity select bit
		0 Low active when chip is in Power Down
		1 High active when chip is in PowerDown
1	SWRST	Internal soft reset activation bit
		0 Normal operation
		1 Internal soft reset is applied and auto cleared

WUER Wakeup Source Enable Register

The Wakeup Source Enable register enables the wakeup source when the chip is in Power Down mode. Wakeup sources which will be used as the source of chip wakeup should be enabled in each bit field. If the source will be used as the wakeup source, write '1' to its enable bit. If the source will not be used as the wakeup source, write 0 to its enable bit.

This register is a 16-bit register.

WUER=0x4000_0010

15	14	13	12	11	10	9	8	7	6	5	4	3	2	1	0
		GPIOFWUE	GPIOEWUE	GPIODWUE	GPIOCWUE	GPIOBWUE	GPIOAWUE						FRTWUE	WDTWUE	LVDWUE
0	0	0	0	0	0	0	0	0	0	0	0	0	0	0	0
		RW	RW	RW	RW	RW	RW						RW	RW	RW

13	GPIOFWUE	Enable wakeup source of GPIOF port pin change event 0 Not used for wakeup source 1 Enable the wakeup event generation
12	GPIOEWUE	Enable wakeup source of GPIOE port pin change event 0 Not used for wakeup source 1 Enable the wakeup event generation
11	GPIODWUE	Enable wakeup source of GPIOD port pin change event 0 Not used for wakeup source 1 Enable the wakeup event generation
10	GPIOCWUE	Enable wakeup source of GPIOC port pin change event 0 Not used for wakeup source 1 Enable the wakeup event generation
9	GPIOBWUE	Enable wakeup source of GPIOB port pin change event 0 Not used for wakeup source 1 Enable the wakeup event generation
8	GPIOAWUE	Enable wakeup source of GPIOA port pin change event 0 Not used for wakeup source 1 Enable the wakeup event generation
2	FRTWUE	Enable wakeup source of free run timer event 0 Not used for wakeup source 1 Enable the wakeup event generation
1	WDTWUE	Enable wakeup source of watchdog timer event 0 Not used for wakeup source 1 Enable the wakeup event generation
0	LVDWUE	Enable wakeup source of LVD event 0 Not used for wakeup source 1 Enable the wakeup event generation

WUSR Wakeup Source Status Register

When the system is woken up by any wakeup source, the wakeup source is identified by reading the Wakeup Source Status register. When the bit is set to 1, the related wakeup source issues the wakeup to the SCU. The bit will be cleared when the event is cleared by the software.

WUSR=0x4000_0014

15	14	13	12	11	10	9	8	7	6	5	4	3	2	1	0
		GPIOFWU	GPIOEWU	GPIODWU	GPIOCWU	GPIOBWU	GPIOAWU						FRTWU	WDTWU	LVDWU
0	0	0	0	0	0	0	0	0	0	0	0	0	0	0	0
		R	R	R	R	R	R						R	R	R

13	GPIOFWU	Status of wakeup source of GPIOF port pin change event
		0 No wakeup event
		1 Wakeup event was generated
12	GPIOEWU	Status of wakeup source of GPIOE port pin change event
		0 No wakeup event
		1 Wakeup event was generated
11	GPIODWU	Status of wakeup source of GPIOD port pin change event
		0 No wakeup event
		1 Wakeup event was generated
10	GPIOCWU	Status of wakeup source of GPIOC port pin change event
		0 No wakeup event
		1 Wakeup event was generated
9	GPIOBWU	Status of wakeup source of GPIOB port pin change event
		0 No wakeup event
		1 Wakeup event was generated
8	GPIOAWU	Status of wakeup source of GPIOA port pin change event
		0 No wakeup event
		1 Wakeup event was generated
2	FRTWU	Status of wakeup source of free run timer event
		0 No wakeup event
		1 Wakeup event was generated
1	WDTWU	Status of wakeup source of watchdog timer event
		0 No wakeup event
		1 Wakeup event was generated
0	LVDWU	Status of wakeup source of LVD event
		0 No wakeup event
		1 Wakeup event was generated

RSER Reset Source Enable Register

The reset source which will generate the reset event can be selected by the Reset Source Enable register. When writing 1 to the bit field of each reset source, the reset source event will be transferred to the reset generator. When writing 0 to the bit field of each reset source, the reset source event will be masked and will not generate a reset event.

RSER=0x4000_0018

7	6	5	4	3	2	1	0
	PINRST	CORERST	SWRST	WDRST	MCKFRST	XFRST	LVDRST
0	1	0	0	1	0	0	1
	RW	RW	RW	RW	RW	RW	RW

6	PINRST	External pin reset enable bit
	0	Reset from this event is masked
	1	Reset from this event is enabled
5	CPURST	CPU request reset enable bit
	0	Reset from this event is masked
	1	Reset from this event is enabled
4	SWRST	Software reset enable bit
	0	Reset from this event is masked
	1	Reset from this event is enabled
3	WDRST	Watchdog Timer reset enable bit
	0	Reset from this event is masked
	1	Reset from this event is enabled
2	MCKFRST	MCLK Clock fail reset enable bit
	0	Reset from this event is masked
	1	Reset from this event is enabled
1	XFRST	External OSC Clock fail reset enable bit
	0	Reset from this event is masked
	1	Reset from this event is enabled
0	LVDRST	LVD reset enable bit
	0	Reset from this event is masked
	1	Reset from this event is enabled

RSSR Reset Source Status Register

The Reset Source Status register shows the reset source information when a reset event occurs. “1” indicates that a reset event exists and “0” indicates that a reset event does not exist for a reset source. When the reset source is found, writing “1” to the corresponding bit will clear the reset status.

This register is an 8-bit register.

RSSR=0x4000_001C

7	6	5	4	3	2	1	0
PORST	PINRST	CORERST	SWRST	WDTRST	MCKFRST	XFRST	LVDRST
1	0	0	0	0	0	0	0
RC1	RC1	RC1	RC1	RC1	RC1	RC1	RC1

7	PORST	Power on reset status bit
0		Read : Reset from this event was not exist Write : no effect
1		Read :Reset from this event was occurred Write : Clear the status
6	PINRST	External pin reset status bit
0		Read : Reset from this event was not exist Write : no effect
1		Read :Reset from this event was occurred Write : Clear the status
5	CPURST	CPU request reset status bit
0		Read : Reset from this event was not exist Write : no effect
1		Read :Reset from this event was occurred Write : Clear the status
4	SWRST	Software reset status bit
0		Read : Reset from this event was not exist Write : no effect
1		Read :Reset from this event was occurred Write : Clear the status
3	WDTRST	Watchdog Timer reset status bit
0		Read : Reset from this event was not exist Write : no effect
1		Read :Reset from this event was occurred Write : Clear the status
1	XFRST	Clock fail reset status bit
0		Read : Reset from this event was not exist Write : no effect
1		Read :Reset from this event was occurred Write : Clear the status
0	LVDRST	LVD reset status bit
0		Read : Reset from this event was not exist Write : no effect
1		Read :Reset from this event was occurred Write : Clear the status

PRER1 Peripheral Reset Enable Register 1

The reset of each peripheral by an event reset can be masked by a user setting. The Peripheral Reset Enable register controls enabling of the event reset. If the corresponding bit is '1', the peripheral corresponds with this bit and accepts the reset event. Otherwise, the peripheral is protected from the reset event and maintains its current operation.

When a reset is issued (enabled by the RSER register), you can configure each peripheral to either reset the registers to the default settings or ignore the reset. This applies to all resets except for removal of power.

Caution: If you disable the SCU reset response, you may not be able to connect via the debugger without a power off and on reset. Caution should also be applied with the GPIO/PCU peripherals because the debugger uses these as well.

PRER1=0x4000_0020

31	30	29	28	27	26	25	24	23	22	21	20	19	18	17	16	15	14	13	12	11	10	9	8	7	6	5	4	3	2	1	0		
						TIMER9	TIMER8	TIMER7	TIMER6	TIMER5	TIMER4	TIMER3	TIMER2	TIMER1	TIMER0				GPIOF	GPIOE	GPIOD	GPIOC	GPIOB	GPIOA	FRT				DMA	PCU	WDT	FMC	SCU
0	0	0	0	0	0	1	1	1	1	1	1	1	1	1	1	0	0	1	1	1	1	1	1	1	1	0	0	1	1	1	1	1	
						RW	RW	RW	RW	RW	RW	RW	RW	RW	RW			RW	RW	RW	RW	RW	RW	RW	RW			RW	RW	RW	RW	RW	

25	TIMER9	TIMER9 reset mask
24	TIMER8	TIMER8 reset mask
23	TIMER7	TIMER3 reset mask
22	TIMER6	TIMER2 reset mask
21	TIMER5	TIMER1 reset mask
20	TIMER4	TIMER0 reset mask
19	TIMER3	TIMER3 reset mask
18	TIMER2	TIMER2 reset mask
17	TIMER1	TIMER1 reset mask
16	TIMER0	TIMER0 reset mask
13	GPIOF	GPIOF reset mask
12	GPIOE	GPIOE reset mask
11	GPIOD	GPIOE reset mask
10	GPIOC	GPIOE reset mask
9	GPIOB	GPIOE reset mask
8	GPIOA	GPIOA reset mask
7	FRT	FRT reset mask
4	DMA	DMA reset mask
3	PCU	Port Control Unit reset mask
2	WDT	Watchdog Timer reset mask
1	FMC	Flash memory controller reset mask
0	SCU	System Control Unit reset mask

PRER2 Peripheral Reset Enable Register 2

Peripheral Reset Enable Register 2 is a 32-bit register (See PRER1 for a full explanation of this register).

PRER2=0x4000_0024

31	30	29	28	27	26	25	24	23	22	21	20	19	18	17	16	15	14	13	12	11	10	9	8	7	6	5	4	3	2	1	0
										ADC1	ADC0			MPWM1	MPWM0					UART3	UART2	UART1	UART0			I2C1	I2C0			SPI1	SPI0
0	0	0	0	0	0	0	0	1	0	1	1	0	0	1	1	0	0	0	0	1	1	1	1	0	0	1	1	0	0	1	1
								RW		RW	RW			RW	RW					RW	RW	RW	RW			RW	RW			RW	RW

21	ADC1	ADC1 reset enable
20	ADC0	ADC0 reset enable
17	MPWM1	MPWM1 reset enable
16	MPWM0	MPWM0 reset enable
11	UART3	UART3 reset enable
10	UART2	UART2 reset enable
9	UART1	UART1 reset enable
8	UART0	UART0 reset enable
5	I2C1	I2C1 reset enable
4	I2C0	I2C0 reset enable
1	SPI1	SPI1 reset enable
0	SPI0	SPI0 reset enable

PER1 Peripheral Enable Register 1

All the peripherals are disabled by default except SPI0 and UART0.

To use the peripheral unit, activate it by writing "1" to the corresponding bit in the PER0/1 register. When the bit for the peripheral unit is cleared ("0"), the peripheral will stay in a reset state.

PER1=0x4000_0028

31	30	29	28	27	26	25	24	23	22	21	20	19	18	17	16	15	14	13	12	11	10	9	8	7	6	5	4	3	2	1	0	
						TIMER9	TIMER8	TIMER7	TIMER6	TIMER5	TIMER4	TIMER3	TIMER2	TIMER1	TIMER0				GPIOF	GPIOE	GPIOD	GPIOC	GPIOB	GPIOA	FRT				DMA			
0	0	0	0	0	0	0	0	0	0	0	0	0	0	0	0	0	0	0	0	0	0	0	0	0	0	0	0	0	1	1	1	1
						RW	RW	RW				RW	RW	RW	RW			RW	RW	RW	RW	RW	RW				RW	R	R	R	R	

25	TIMER9	TIMER9 function enable
24	TIMER8	TIMER8 function enable
23	TIMER7	TIMER7 function enable
22	TIMER6	TIMER6 function enable
21	TIMER5	TIMER5 function enable
20	TIMER4	TIMER4 function enable
19	TIMER3	TIMER3 function enable
18	TIMER2	TIMER2 function enable
17	TIMER1	TIMER1 function enable
16	TIMER0	TIMER0 function enable
13	GPIOF	GPIOF function enable
12	GPIOE	GPIOE function enable
11	GPIOD	GPIOD function enable
10	GPIOC	GPIOC function enable
9	GPIOB	GPIOB function enable
8	GPIOA	GPIOA function enable
7	FRT	FRT function enable
4	DMA	DMA function enable
3		
2		
1		Reserved
0		

PER2 Peripheral Enable Register 2

Peripheral Enable Register 2 is a 32-bit register.

PER2=0x4000_002C

31	30	29	28	27	26	25	24	23	22	21	20	19	18	17	16	15	14	13	12	11	10	9	8	7	6	5	4	3	2	1	0
										ADC1	ADC0			MPWM1	MPWM0					UART3	UART2	UART1	UART0			I2C1	I2C0			SPI1	SPI0
0	0	0	0	0	0	0	0	0	0	0	0	0	0	0	0	0	0	0	0	0	0	0	1	0	0	0	0	0	0	0	1
								RW		RW	RW			RW	RW					RW	RW	RW	RW			RW	RW			RW	RW

21	ADC1	ADC1 function enable
20	ADC0	ADC0 function enable
17	MPWM1	MPWM1 function enable
16	MPWM0	MPWM0 function enable
11	UART3	UART3 function enable
10	UART2	UART2 function enable
9	UART1	UART1 function enable
8	UART0	UART0 function enable
5	I2C1	I2C1 function enable
4	I2C0	I2C0 function enable
1	SPI1	SPI1 function enable
0	SPI0	SPI0 function enable

PCER1 Peripheral Clock Enable Register 1

To use the peripheral unit, its clock should be activated by writing '1' to the corresponding bit in the PCER0/1 register. Before enabling its clock, the peripheral will not operate correctly.

To stop the clock of the peripheral unit, write '0' to the corresponding bit in the PCER0/1 register, after which the clock of the peripheral is stopped.

PCER1=0x4000_0030

31	30	29	28	27	26	25	24	23	22	21	20	19	18	17	16	15	14	13	12	11	10	9	8	7	6	5	4	3	2	1	0		
						TIMER9	TIMER8	TIMER7	TIMER6	TIMER5	TIMER4	TIMER3	TIMER2	TIMER1	TIMER0				GPIOF	GPIOE	GPIOD	GPIOC	GPIOB	GPIOA	FRT				DMA				
0	0	0	0	0	0	0	0	0	0	0	0	0	0	0	0	0	0	0	0	0	0	0	0	0	0	0	0	0	1	1	1	1	
						RW	RW	RW				RW	RW	RW	RW				RW	RW	RW	RW	RW	RW				RW	R	R	R	R	

25	TIMER9	TIMER9 clock enable
24	TIMER8	TIMER8 clock enable
23	TIMER7	TIMER7 clock enable
22	TIMER6	TIMER6 clock enable
21	TIMER5	TIMER5 clock enable
20	TIMER4	TIMER4 clock enable
19	TIMER3	TIMER3 clock enable
18	TIMER2	TIMER2 clock enable
17	TIMER1	TIMER1 clock enable
16	TIMER0	TIMER0 clock enable
13	GPIOF	GPIOF clock enable
12	GPIOE	GPIOE clock enable
11	GPIOD	GPIOD clock enable
10	GPIOC	GPIOC clock enable
9	GPIOB	GPIOB clock enable
8	GPIOA	GPIOA clock enable
7	FRT	FRT clock enable
4	DMA	DMA clock enable
3		
2		
1		Reserved
0		

PCER2 Peripheral Clock Enable Register 2

To use the peripheral unit, its clock should be activated by writing '1' to the corresponding bit.

PCER2=0x4000_0034

31	30	29	28	27	26	25	24	23	22	21	20	19	18	17	16	15	14	13	12	11	10	9	8	7	6	5	4	3	2	1	0
										ADC1	ADC0			MPWM1	MWPM0					UART3	UART2	UART1	UART0			I2C1	I2C0			SPI1	SPI0
0	0	0	0	0	0	0	0	0	0	0	0	0	0	0	0	0	0	0	0	0	0	0	1	0	0	0	0	0	0	0	1
										RW	RW			RW	RW					RW	RW	RW	RW			RW	RW			RW	RW

21	ADC1	ADC1 clock enable
20	ADC0	ADC0 clock enable
17	MPWM1	MPWM1 clock enable
16	MPWM0	MPWM0 clock enable
11	UART3	UART3 clock enable
10	UART2	UART2 clock enable
9	UART1	UART1 clock enable
8	UART0	UART0 clock enable
5	I2C1	I2C1 clock enable
4	I2C0	I2C0 clock enable
1	SPI1	SPI1 clock enable
0	SPI0	SPI0 clock enable

CSCR Clock Source Control Register

The Z32F384 MCU has multiple clock sources to generate internal operating clocks. Each clock source can be enabled or disabled by the CSCR register.

This register is an 8-bit register.

CSCR=0x4000_0040

7	6	5	4	3	2	1	0
SXOSCEN		RINGOSCCON		IOSCCON		EOSCCON	
0		10		00		00	
RW		RW		RW		RW	

7	SXOSCEN	External Sub Oscillator Enable
0		Disable Sub Oscillator
1		Enable Sub Oscillator
5	RINGOSCCON	Internal ring oscillator control
4		0X Stop internal sub oscillator
		10 Enable internal sub oscillator
		11 Enable internal sub oscillator divide by 2
3	IOSCCON	Internal oscillator control
2		0X Stop internal oscillator
		10 Enable internal oscillator
		11 Enable internal oscillator divide by 2
1	EOSCON	External crystal oscillator control
0		0X Stop internal oscillator
		10 Enable internal oscillator
		11 Enable internal oscillator divide by 2

SCCR System Clock Control Register

The System Clock Control register is the source for the PLL system and clock selection.

FINSEL selects either the IOSC or the External OSC as the input to the PLL system. The System clock select selects internal sub oscillator (Ring), External OSC, Internal OSC or PLL.

When changing FINSEL to MOSC ("1"), both internal OSC and external OSC should be alive, otherwise the chip will malfunction.

SCCR=0x4000_0044

7	6	5	4	3	2	1	0
						FINSEL	MCLKSEL
-						0	00
R						RW	RW

2	FINSEL	PLL input source FIN select register
0		IOSC clock is used as FIN clock
1		MOSC clock is used as FIN clock
1	MCLKSEL	System clock select register
0		0X Internal sub oscillator
		10 PLL bypassed clock
		11 PLL output clock

CMR Clock Monitoring Register

You can monitor the internal clock and external oscillators. To enable monitoring, the MCLKMNT/EOSCMNT/SXOSCMNT bits must be set before the MCLKSTS, EOSCSTS, and SXOSCSTS bits are valid.

Note: The EOSCSTS bit only checks for the EOSCSTS oscillation and does not check for stability. When the system detects an MCLKFAIL interrupt, the MCLKREC bit determines if the system just dies or will auto recover using the ROSC. In most cases, the system should auto recover to keep running. The Clock Monitoring register is a 16-bit register.

Note: Oscillator clock statuses only refer to oscillation and are not necessarily stable. After enabling a clock, check the status for oscillation, then wait for stability before using the clock.

MR=0x4000_0048

15	14	13	12	11	10	9	8	7	6	5	4	3	2	1	0
MCLKREC				SXOSCMNT	SXOSCIE	SXOSCFAIL	SXOSCSTS	MCLKMNT	MCLKIE	MCLKFAIL	MCLKSTS	EOSCMNT	EOSCIE	EOSCFAIL	EOSCSTS
0	0	0	0	0	0	0	1	0	0	0	1	0	0	0	1
R				RW	RW	WC1	WC1	RW	RW	WC1	WC1	RW	RW	WC1	WC1

15	MCLKREC	MCLK fail auto recovery
0		MCLK is changed to RINGOSC by default when MCLKFAIL issued
1		MCLK auto recovery is disabled
11	SXOSCMNT	Sub Oscillator monitoring enable
0		Sub Oscillator monitoring disabled
1		Sub Oscillator monitoring enabled
10	SXOSCIE	Sub Oscillator fail interrupt enable
0		Sub Oscillator fail interrupt disabled
1		Sub Oscillator fail interrupt enabled
9	SXOSCFAIL	Sub Oscillator fail interrupt
0		Sub Oscillator fail interrupt not occurred
1		Read : Sub Oscillator fail interrupt is pending Write : Clear pending interrupt
8	SXOSCSTS	Sub Oscillator clock status
0		Not oscillate
1		Sub oscillator is working normally
7	MCLKMNT	MCLK monitoring enable
0		MCLK monitoring disabled
1		MCLK monitoring enabled
6	MCLKIE	MCLK fail interrupt enable
0		MCLK fail interrupt disabled
1		MCLK fail interrupt enabled
5	MCLKFAIL	MCLK fail interrupt
0		MCLK fail interrupt not occurred
1		Read : MCLK fail interrupt is pending Write : Clear pending interrupt
4	MCLKSTS	MCLK clock status
0		No clock is present on MCLK
1		Clock is present on MCLK
3	EOSCMNT	External oscillator monitoring enable
0		External oscillator monitoring disabled
1		External oscillator monitoring enabled
2	EOSCIE	External oscillator fail interrupt enable
0		External oscillator fail interrupt disabled

		1	External oscillator fail interrupt enabled
1	EOSCFAIL		External oscillator fail interrupt
		0	External oscillator fail interrupt not occurred
		1	Read : External oscillator fail interrupt is pending Write : Clear pending interrupt
0	EOSCSTS		External oscillator status
		0	Not oscillate
		1	External oscillator is working normally

NMIR NMI Control Register

The NMI Control register provides control and status for Non-Maskable Interrupt. There are 6 available NMI sources. Write access key is required 0xA32 on NMIR[31:20] when writing to this register.

NMIR = 0x4000_004C

31	30	29	28	27	26	25	24	23	22	21	20	19	18	17	16	15	14	13	12	11	10	9	8	7	6	5	4	3	2	1	0												
REG ('hA)		ACCESS ('h3)		CODE ('h2)		NMIPINSTS		NMIINT		NMIPINDBEN		NMIINTSTS		PROT1STS		OVP1STS		PROT0STS		OVP0STS		WDTSTS		MCLKFAILSTS		BODSTS		NIMPINEN		PROT1EN		OVP1EN		PROT0EN		OVP0EN		WDTEN		MCLKFAILEN		LV DEN	
						1 0 1						0 0 0 0 0 0 0 0												1 0 0 0 0 0 0 0																			
						R WC1RW						R R R R R R R R												RW RW RW RW RW RW RW RW																			

19	NMIPINSTS	NMI pin status bit
		0 NMI pin is low.
		1 NMI pin is high.
18	NMIINT	NMI interrupt bit, Write 1 to clear
		0 NMI interrupt is not pending
		1 NMI interrupt is pending
17	NMIPINDBEN	NMI pin debounce enable
		0 Disable
		1 Enable
15	NMIINTSTS	NMI pin interrupt status bit
		0 NMI interrupt is not pending
		1 NMI interrupt is pending
14	PROT1STS	MPWM1's Protection interrupt status bit.
		0 No PROT1 interrupt
		1 PROT1 interrupt occurred
13	OVP1STS	MPWM1's Over Voltage Protection interrupt status bit
		0 No OVP1 interrupt
		1 OVP1 interrupt occurred
12	PROT0STS	MPWM0's Protection interrupt status bit.
		0 No PROT0 interrupt
		1 PROT interrupt occurred
11	OVP0STS	MPWM0's Over Voltage Protection interrupt status bit
		0 No OVP0 interrupt
		1 OVP0 interrupt occurred
10	WDTINTSTS	WDT Interrupt status bit
		0 No WDT interrupt
		1 WDT interrupt occurred
9	MCLKFAILSTS	MCLK Fail interrupt status bit
		0 No MCLK fail interrupt
		1 MCLK fail interrupt occurred
8	BODSTS	BOD interrupt status bit
		0 No BOD interrupt
		1 BOD interrupt occurred

7	NMIPINEN	NMI pin interrupt Enable Write permission is required by PCU write enable sequence
		0 Disable
		1 Enable
6	PROT1EN	MPWM1's Protection interrupt enable for NMI interrupt
		0 Disable
		1 Enable
5	OVP1EN	MPWM1's Over Voltage Protection interrupt enable for NMI interrupt
		0 Disable
		1 Enable
4	PROT0EN	MPWM0's Protection interrupt enable for NMI interrupt
		0 Disable
		1 Enable
3	OVP0EN	MPWM0's Over Voltage Protection interrupt enable for NMI interrupt
		0 Disable
		1 Enable
2	WDTINTEN	WDT Interrupt condition enable for NMI interrupt
		0 Disable
		1 Enable
1	MCLKFAILEN	MCLK Fail condition enable for NMI interrupt
		0 Disable
		1 Enable
0	LVDEN	LVD Detect condition enable for NMI interrupt
		0 Disable
		1 Enable

COR Clock Output Register

The Clock Output register controls enabling/disabling and provides a divider for the clock output. To output the clock signal, you must enable the clock out function pin (See Chapter 5, Port Control Unit).

COR=0x4000_0050

7	6	5	4	3	2	1	0
-			CLKOEN	CLKODIV			
000			0	1111			
R			RW	RW			

4 CLKOEN

Clock output enable

0 CLKO is disabled and stay "L" output

1 CLKO is enabled

3 CLKODIV

Clock output divider value

0

$CLKO = MCLK \quad (CLKODIV = 0)$

$$CLKO = \frac{MCLK}{2 * (CLKODIV + 1)} \quad (CLKODIV > 0)$$

PLLCON PLL Control Register

Integrated PLL can synthesize the high speed clock for extremely high performance of the CPU from either the internal oscillator (IOSC) or the external oscillator (MOSC). The PLL Control register provides the configuration for the PLL system. By default, the PLL system is in reset mode and disabled. You must negate the reset and enable the PLL to operate (bits 14 and 15 must be set). The Bypass bit must be set to output the PLL clock. The active clock is defined in SCCR bit 2 (FIN).

To calculate the PLL output:

$$\text{PLL Out} = ((\text{Active clock} / \text{PREDIV}) * \text{FBCTRL}) / \text{POSTDIV}$$

Note: (Active Clock/PREDIV) * FBCTRL must be below 224 MHz else PLL will not lock.

PLLCON=0x4000_0060

15	14	13	12	11	10	9	8	7	6	5	4	3	2	1	0
PLLSTB	PLEN	BYPASS	LOCKSTS				PREDIV	FBCTRL				POSTDIV			
0	0	0	0	0	0	0	0	0000				0000			
RW	RW	RW	R				RW	RW				RW			

15	PLLSTB	PLL reset			
	0	PLL reset is asserted			
	1	PLL reset is negated			
14	PLEN	PLL enable			
	0	PLL is disabled			
	1	PLL is enabled			
13	BYPASS	FIN bypass			
	0	FOUT is bypassed as FIN			
	1	FOUT is PLL output			
12	LOCK	LOCK status			
	0	PLL is not locked			
	1	PLL is locked			
8	PREDIV	FIN predivider			
	0	FIN divided by 1			
	1	FIN divided by 2			
7	FBCTRL	Feedback control			
4		0000	M = 8	1000	M = 30
		0001	M = 12	1001	M = 32
		0010	M = 14	1010	M = 38
		0011	M = 16	1011	M = 40
		0100	M = 18	1100	Not available
		0101	M = 20	1101	
		0110	M = 22	1110	
	0111	M = 28	1111		
3	POSTDIV	Post divider control			
0		000	N = 1		
		001	N = 2		
		010	N = 3		
		011	N = 4		
		100	N = 6		
		101	N = 8		
		110	N = 12		
	111	N = 16			

VDCCON VDC Control Register

The on chip VDC control register is shown below.

VDCTRIM is used for the trim value of VDC output. To modify the VDCTRIM bit, VDCTE should write “1” simultaneously. VDCWDLY value can be written with writing “1” to VDCDE bit simultaneously.

VDCCON=0x4000_0064

31	30	29	28	27	26	25	24	23	22	21	20	19	18	17	16	15	14	13	12	11	10	9	8	7	6	5	4	3	2	1	0
BM RTE		BM RTRIM					VDCTE				VDCTRIM				VDCDE				VDCWDLY												
0 0 0 0 0		00					0 0 0 0				0000				0 0 0 0 0 0 0 0				0x0F												
W		RW					W				RW				W				RW												

31	BM RTE	Reference BGR trim write enable. 0 BM RTRIM field is not updated by writing 1 BM RTRIM field can be updated by writing
26 24	BM RTRIM	Reference BGR output voltage trim value
23	VDCTE	VDCTRIM value write enable. Write only with VDCTRIM value. 0 VDCTRIM field is not updated by writing 1 VDCTRIM field can be updated by writing
19 16	VDCTRIM	VDC output voltage trim value
8	VDCDE	VDCWDLY value write enable. Write only with VDCWDLY value 0 VDCWDLY field is not updated by writing 1 VDCWDLY field can be updated by writing
7 0	VDCWDLY	VDC warm-up delay count value. When SCU is waked up from powerdown mode, the warm-up delay is inserted for VDC output being stabilized. The amount of delay can be defined with this register value 7F : 2msec

LVDCON LVD Control Register

The on chip brown-out detector control register is a 32-bit register.

LVDCON=0x4000_0068

31	30	29	28	27	26	25	24	23	22	21	20	19	18	17	16	15	14	13	12	11	10	9	8	7	6	5	4	3	2	1	0			
								BODTE							BODTRIM	SELEN								BODSEL									BODLVL	BODEN
0	0	0	0	0	0	0	0	0	0	0	0	0	0	00	0	0	0	0	0	0	0	00	0	0	0	0	0	0	0	0	0	0	0	1
								RW						RW	RW								RW									RW	RW	

23	BODTE	BODTRIM value write enable. Write only with BODTRIM value.
	0	BODTRIM field is not updated by writing
	1	BODTRIM field can be updated by writing
17	BODTRIM	BOD voltage level trim value
16		It can be written when trim enable mode in FMC
9	BODSEL	BOD detect level select
8		00 BOD detect level is 1.8V- 50mV
		01 BOD detect level is 2.2V - 50mV
		10 BOD detect level is 2.7V -50mV
		11 BOD detect level is 4.3V - 50mV
0	BODEN	BOD Function enable
	0	BOD is not enabled
	1	BOD is enabled

IOSCTRIM Internal OSC Trim Register

The Internal Oscillator Frequency Trim register. Is a 32-bit register. All trim bits are writable when trim mode in FMC is enabled.

IOSCTRIM=0x4000_006C

31	30	29	28	27	26	25	24	23	22	21	20	19	18	17	16	15	14	13	12	11	10	9	8	7	6	5	4	3	2	1	0	
								TSL[EN]						TSL		LT[EN]				LT			LTM		UDC[EN]				UDCH			UDCL
0	0	0	0	0	0	0	0	0	0	0	0	0	0	000		0	0			0000			00		0	0	0		00			000
								W						RW		W				RW			RW		W				RW			RW

23	TSL[EN]	TSL trim value write enable. Write only with TSL trim value.
		0 TSL field is not updated by writing
		1 TSL field can be updated by writing
18	TSL[2:0]	TSL trim value
16		
15	LT[EN]	LTM/LT value write enable. Write only with LTM/LT value
		0 LT field is not updated by writing
		1 LT field can be updated by writing
13	LTM/LT	Internal oscillator LT trim value
8		
7	UDC[EN]	UDCH/UDCL value write enable. Write only with UDC value
		0 UDC field is not updated by writing
		1 UDC field can be updated by writing
4	UDCH/UDCL	Internal oscillator UDC trim value
0		

EOSCR External Oscillator Control Register

The External Oscillator Control register is a 16-bit register. The external main crystal oscillator has two characteristics. For noise immunity, NMOS amp type is recommended and for the low power characteristic, INV amp type is recommended.

EOSCR=0x4000_0080

15	14	13	12	11	10	9	8	7	6	5	4	3	2	1	0
I[SE]L[EN]							I[SE]L	N[CE]N							N[CE]S[EL]
0	0	0	0	0	0		00	0	0	0	0	0	0		10
W							RW	W							RW

15	I[SE]L[EN]	Write enable of bit field I[SE]L.
		0 Write access of I[SE]L field is masked
		1 Write access of I[SE]L field is accepted
9	I[SE]L	Select current. Default 0x0
8		00 Minimum current driving option
		01 Low current driving option

		10	High current driving option
		11	Maximum current driving option
7	NCEN	Write enable of bit field NCSEL	
		0	Write access of NCSEL field is masked
		1	Write access of NCSEL field is accepted
1	NCSEL	Select noise cancel delay , default 0x2	
0		00	10ns
		01	15ns
		10	20ns
		11	25ns

Freq. (MHz)	ISEL_I<1:0>	NCSEL_I<1:0>	NC DELAY (ns)
4	<00>	<11>	25
8	<00>	<10>	20
12	<01>	<01>	15
16	<11>	<00>	10

EMODR External Mode Status Register

The External Mode Status register shows external mode pin status while booting. This register is an 8-bit register.

EMODR=0x4000_0084

7	6	5	4	3	2	1	0
					SCANMD	TEST	BOOT
0x0					0	0	-
R					R	R	R

2	SCANMD	SCANMD pin level
		0 SCANMD pin is low
1	TEST	1 SCANMD pin is high
		TEST pin level
0	BOOT	0 TEST pin is low
		1 TEST pin is high
		BOOT pin level
		0 BOOT(PC11) pin is low
		1 BOOT(PC11) pin is high

DBCLK1 Debounce Clock Control Register 1

The Debounce Clock Control Register 1 is a register for PA and PB port pins.

MCCR4=0x4000_009C

31	30	29	28	27	26	25	24	23	22	21	20	19	18	17	16	15	14	13	12	11	10	9	8	7	6	5	4	3	2	1	0
							PBDCSEL																PADCSEL								PADDIV
0	0	0	0	0			000								0x01	0	0	0	0	0			000								0x01
							RW								RW								RW								RW

26	PBDCSEL	Debounce Clock for Port B source select bit
24		0xx RING OSC 1MHz
		100 MCLK (bus clock)
		101 INT OSC 20MHz
		110 External Main OSC
		111 PLL Clock
23	PBDDIV	PORT B Debounce Clock N divider
16		
10	PADCSEL	Debounce Clock for Port A source select bit
8		0xx RING OSC 1MHz
		100 MCLK (bus clock)
		101 INT OSC 20MHz
		110 External Main OSC
		111 PLL Clock
7	PADDIV	PORT A Debounce Clock N divider
0		

DBCLK2 Debounce Clock Control Register 2

The Debounce Clock Control Register 2 is a register for PC and PD port pins.

MCCR5=0x4000_00A0

31	30	29	28	27	26	25	24	23	22	21	20	19	18	17	16	15	14	13	12	11	10	9	8	7	6	5	4	3	2	1	0
							PDDCSEL																PCDCSEL								PCDDIV
0	0	0	0	0			000									0	0	0	0	0			000								0x01
							RW																RW								RW

26	PDDCSEL	Debounce Clock for PORT D source select bit
24		0xx RING OSC 1MHz
		100 MCLK (bus clock)
		101 INT OSC 20MHz
		110 External Main OSC
		111 PLL Clock
23	PDDDIV	PORT D Debounce Clock N divider
16		
10	PCDCSEL	Debounce Clock for PORT C source select bit
8		0xx RING OSC 1MHz
		100 MCLK (bus clock)
		101 INT OSC 20MHz
		110 External Main OSC
		111 PLL Clock
7	PCDDIV	PORT C Debounce Clock N divider
0		

DBCLK3 Debounce Clock Control Register 3

The Debounce Clock Control Register 3 is a register for PE and PF port pins.

0x4000_00A4

31	30	29	28	27	26	25	24	23	22	21	20	19	18	17	16	15	14	13	12	11	10	9	8	7	6	5	4	3	2	1	0
							PFDCSEL																								
0	0	0	0	0			000									0	0	0	0	0			000								
							RW																								

- 26 PFDCSEL Debounce Clock for PORT F source select bit
- 24 0xx RING OSC 1MHz
- 100 MCLK (bus clock)
- 101 INT OSC 20MHz
- 110 External Main OSC
- 111 PLL Clock
- 23 PFDDIV PORT F Debounce Clock N divider
- 16
- 10 PEDCSEL Debounce Clock for PORT E source select bit
- 8 0xx RING OSC 1MHz
- 100 MCLK (bus clock)
- 101 INT OSC 20MHz
- 110 External Main OSC
- 111 PLL Clock
- 7 PEDDIV PORT E Debounce Clock N divider
- 0

MCCR1 Miscellaneous Clock Control Register 1

The Miscellaneous Clock Control Register 1 sets Trace and SysTick clock sources and dividers.

MCCR1=0x4000_0090

31	30	29	28	27	26	25	24	23	22	21	20	19	18	17	16	15	14	13	12	11	10	9	8	7	6	5	4	3	2	1	0
TRCPOL						TRCSEL		TRACEDIV								STCSEL				STDIV											
0	0	0	0	0	0	100		0x04								000				0x01											
W						RW		RW								RW				RW											

10	TRCSEL	TRACE Clock source select bit
8		0xx RING OSC 1MHz
		100 MCLK (bus clock)
		101 INT OSC 20MHz
		110 External Main OSC
		111 PLL Clock
7	TRACEDIV	TRACE Clock N divider
0		
10	STCSEL	SYSTIC Clock source select bit
8		0xx RING OSC 1MHz
		100 MCLK (bus clock)
		101 INT OSC 20MHz
		110 External Main OSC
		111 PLL Clock
7	STDIV	SYSTIC Clock N divider
0		

MCCR2 Miscellaneous Clock Control Register 2

The Miscellaneous Clock Control Register 2 is the clock source and divider register for the MPWM generator units.

MCCR2=0x4000_0094

31	30	29	28	27	26	25	24	23	22	21	20	19	18	17	16	15	14	13	12	11	10	9	8	7	6	5	4	3	2	1	0
							PWM1CSEL																PWM0CSEL								PWM0DIV
0	0	0	0	0		000					0x00					0	0	0	0	0		000								0x00	
							RW																RW								RW

10	PWM1CSEL	PWM1 Clock source select bit
8		0xx RING OSC 1MHz
		100 MCLK (bus clock)
		101 INT OSC 20MHz
		110 External Main OSC
		111 PLL Clock
7	PWM1DIV	PWM1 Clock N divider
0		
10	PWM0CSEL	PWM0 Clock source select bit
8		0xx RING OSC 1MHz
		100 MCLK (bus clock)
		101 INT OSC 20MHz
		110 External Main OSC
		111 PLL Clock
7	PWM0DIV	PWM0 Clock N divider
0		

MCCR3 Miscellaneous Clock Control Register 3

The Miscellaneous Clock Control Register 3 is the Timer EXT0 Clock and Watch Dog Timer clock control register.

MCCR3=0x4000_0098

31	30	29	28	27	26	25	24	23	22	21	20	19	18	17	16	15	14	13	12	11	10	9	8	7	6	5	4	3	2	1	0
							TEXT0CSEL																								
0	0	0	0	0			000								0x01	0	0	0	0	0			000								0x01
							RW								RW								RW								RW

10	TEXT0CSEL	TEXT0 Clock source select bit
8		0xx RING OSC 1MHz
		100 MCLK (bus clock)
		101 INT OSC 20MHz
		110 External Main OSC
		111 PLL Clock
7	TEXTODIV	TEXT0 Clock N divider
0		
10	WDTCSSEL	WDT Clock source select bit
8		0xx RING OSC 1MHz
		100 MCLK (bus clock)
		101 INT OSC 20MHz
		110 External Main OSC
		111 PLL Clock
7	WDTDIV	WDT Clock N divider
0		

MCCR4 Miscellaneous Clock Control Register 4

The Miscellaneous Clock Control Register 4 is the alternative ADC and NMI Debounce Clock Control register.

0x4000_00A8

31	30	29	28	27	26	25	24	23	22	21	20	19	18	17	16	15	14	13	12	11	10	9	8	7	6	5	4	3	2	1	0
							ADCCSEL																								
0	0	0	0	0			000								0x00	0	0	0	0	0			000								0x01
							RW								RW								RW								RW

26	ADCCSEL	ADC clock source select bit
24		0xx RING OSC 1MHz
		100 MCLK (bus clock)
		101 INT OSC 20MHz
		110 External Main OSC
		111 PLL Clock
23	ADCCDIV	ADC Clock N divider
16		
10	NMIDCSEL	Debounce Clock for NMI source select bit
8		0xx RING OSC 1MHz
		100 MCLK (bus clock)
		101 INT OSC 20MHz
		110 External Main OSC
		111 PLL Clock
7	NMIDDIV	NMI Debounce Clock N divider
0		

Functional Description

System Clock Setup Procedure Example for the Internal Clock with PLL

- Configure the FM.CFG register to the maximum wait
- Enable the internal clock IOSC in the CSCR register.
- Write 0x02 to the SCCR register (system clock control register) to select the IOSC as the PLL source (FIN) with bypassing the PLL output
- In the PLLCON register, Set bits 14,15 to enable PLL, clear bit 13 to bypass PLL output and configure bits 0-8 to the PREDIV/FBCTRL/POSTDIV for desired PLL output. For full speed, the PLLCON register would be set to 0xC100
- Wait for the PLL to be locked by monitoring the LOCK bit (bit 12) in the PLLCON register.
- Set bit 13 of the PLLCON register to enable the PLL output
- Set bit 0 of SCCR to enable the PLL for the system clock
- Set FM.CFG for the appropriate Flash Wait states for the speed selected.

System Clock Setup Procedure Example for the External Clock with PLL

- Enable the Port C peripheral and clock in the SCU PER1 and PCER1 registers
- Unlock the Port Controller using the PORTEN register as defined in PORT CONTROL UNIT (PCU)
- Enable the Alternative function 11b for pins 12 and 13 on PORT C through the PCC_MR register
- Set the Pin type for pins 12 and 13 on PORT C to analog (11b)
- Lock the Port Controller by writing any value to PORTEN register
- Configure the FM.CFG register to the maximum wait
- If not already enabled, enable Internal oscillator in CSCR
- Set bit 3 in the CMR register to monitor External Oscillator
- Enable External Oscillator in CSCR register
- Wait for bit 0 of the CMR register to be set. Note: if the external oscillator does not start, this bit will never be set.
- Wait for an additional time (more than 1 ms) to allow the oscillator to stabilize
- Write 0x06 to the SCCR register (system clock control register) to select the External Oscillator as the PLL source (FIN)
- Set PLLCON high byte (8-15) to 0xC and low byte (0-7) to the FBCTRL/POSTDIV for desired PLL output.
- Wait until bit 12 of PLLCON is set. Note: if the PLL does not lock, this bit will never be set.
- Set bit 13 to enable the PLL output
- Set bit 0 of SCCR to enable the PLL for the system clock
- Set FM.CFG for the appropriate Flash Wait states for the speed selected.

To Enable Clock Out for monitoring actual clock output

- Enable the Port C peripheral and clock in the SCU PER1 and PCER1 registers
- Unlock the Port Controller using the PORTEN register as defined in PORT CONTROL UNIT (PCU)
- Enable the Alternative function 01b for pin 9 on PORT C through the PCC_MR register
- Set the Pin type for pin 9 on PORT C to output (00b)
- Lock the Port Controller by writing any value to PORTEN register
- Set bit 4 of the Clock Output Register (COR) to enable the output
- Configure the CLKODIV to the desired output divider

5. Port Control Unit

Overview

Port Control Unit (PCU) controls the external I/Os as follows:

- Set the multiplex state of each pin (for alternative functions)
- Set external signal type (Analog / Push-Pull output /Open Drain output /Input)
- Set enable/monitor/trigger type for interrupts for each pin
- Set internal pull-up register control for each pin
- Set debounce for each pin

Note: You must enable both the Port Peripheral and the Port Peripheral CLOCK in PER1/PCER1 to use the pins of the port.

Figure 5.1 shows a block diagram of the PCU. Figures 2.2 and 2.3 show I/O Port Block diagrams.

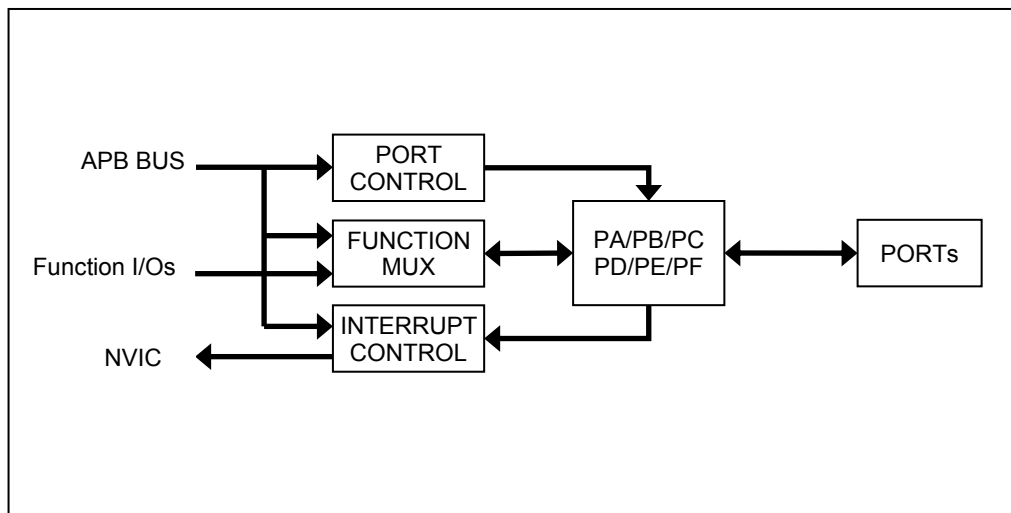

Figure 5.1. Block Diagram

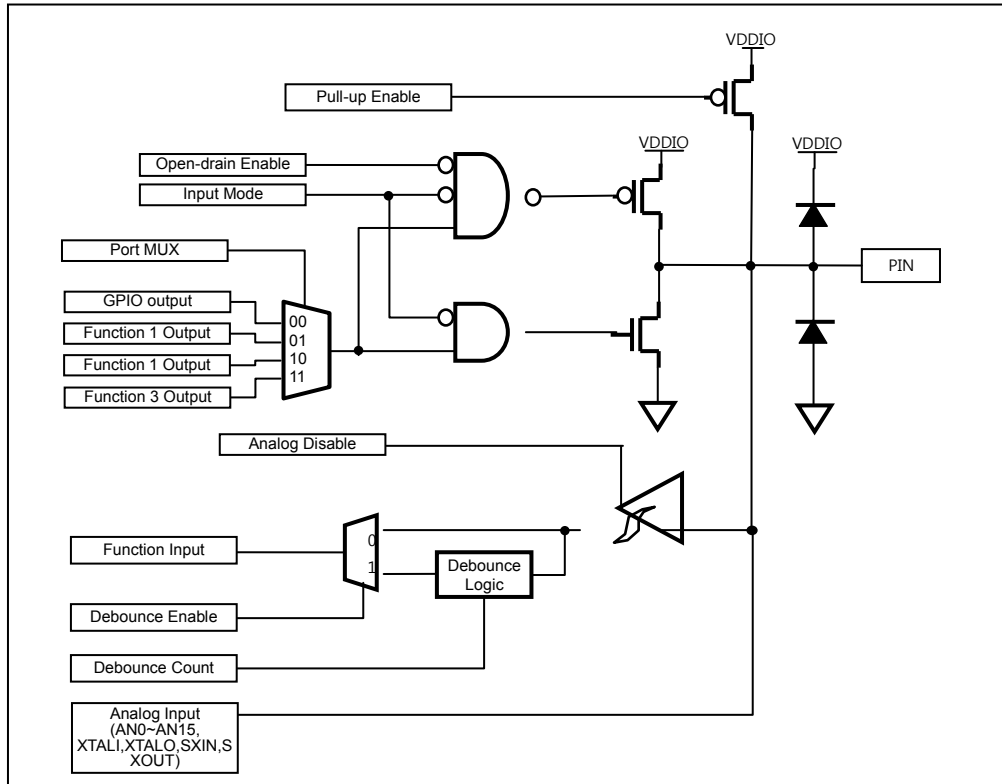

Figure 5.2. I/O Port Block Diagram (ADC and External Oscillator Pins)

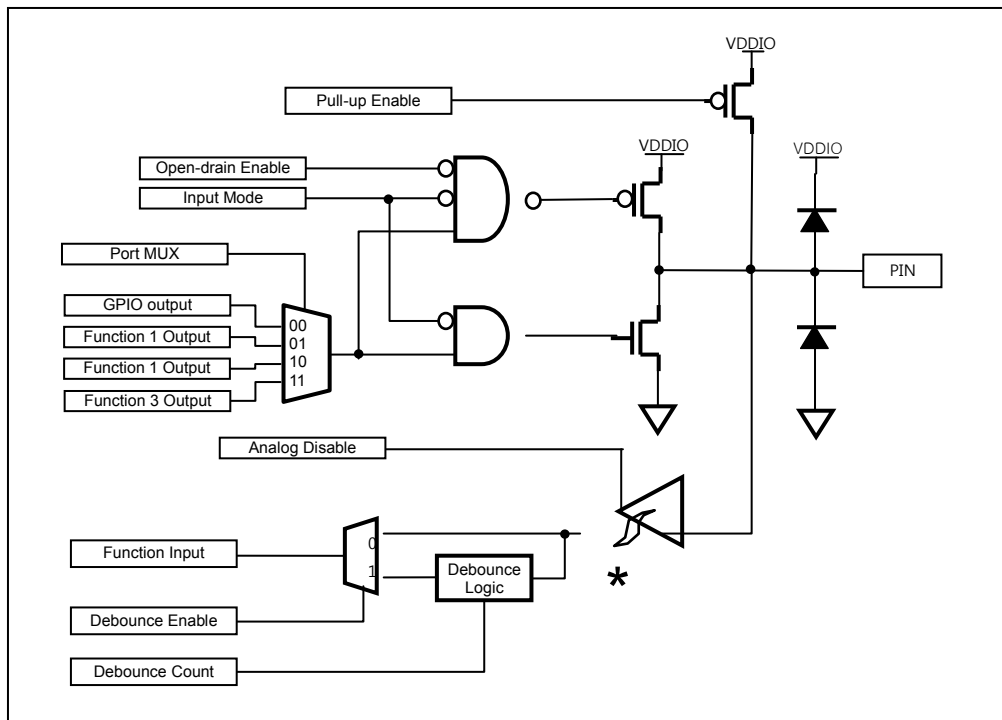

Figure 5.3. I/O Port Block Diagram (General I/O Pins)

Pin Multiplexing

GPIO pins have alternative function pins. Table 5.1 lists the pin multiplexing information.

Table 5.1. GPIO Alternative Function

PORT		FUNCTION			
		00	01	10	11
PA	0	PA0*			AN0
	1	PA1*			AN1
	2	PA2*			AN2
	3	PA3*			AN3
	4	PA4*		T0IO	AN4
	5	PA5*		T1IO	AN5
	6	PA6*		T2IO	AN6
	7	PA7*		T3IO	AN7
	8	PA8*			AN8
	9	PA9*			AN9
	10	PA10*			AN10
	11	PA11*			AN11
	12	PA12*	SS0		AN12
	13	PA13*	SCK0		AN13
	14	PA14*	MOSI0		AN14
15	PA15*	MISO0		AN15	
PB	0	PB0*	MP0UH		
	1	PB1*	MP0UL		
	2	PB2*	MP0VH		
	3	PB3*	MP0VL		
	4	PB4*	MP0WH		
	5	PB5*	MP0WL		
	6	PB6*	PRTIN0	WDTO ⁽²⁾	
	7	PB7*	OVIN0	STBYO ⁽²⁾	
	8	PB8*	PRTIN1	RXD3	
	9	PB9*	OVIN1	TXD3	
	10	PB10*	MP1UH		
	11	PB11*	MP1UL		
	12	PB12*	MP1VH		
	13	PB13*	MP1VL		
	14	PB14*	MP1WH		
15	PB15*	MP1WL			

^(*) mark indicates default pin setting.

⁽²⁾ mark indicates secondary port

Table 5.1. GPIO Alternative Function (Continued)

PORT		FUNCTION			
		00	01	10	11
PC	0	PC0	TCK/SWCLK*	RXD0 ⁽²⁾	
	1	PC1	TMS/SWDIO*	RXD0 ⁽²⁾	
	2	PC2	TDO/SWO*		
	3	PC3	TDI*		
	4	PC4	nTRST*	T0IO ⁽²⁾	
	5	PC5*	RXD1	T1IO ⁽²⁾	
	6	PC6*	TXD1	T2IO ⁽²⁾	
	7	PC7*	SCL0	T3IO ⁽²⁾	
	8	PC8*	SDA0	T4IO ⁽²⁾	
	9	PC9*	CLKO	T8IO	
	10	PC10	nRESET*		
	11	PC11/BOOT*		T8IO ⁽²⁾	
	12	PC12*			XIN
	13	PC13*			XOUT
	14	PC14*	RXD0	MISO0 ⁽²⁾	
15	PC15*	TXD0	MOSI0 ⁽²⁾		
PD	0	PD0*	SS1		SXIN
	1	PD1*	SCK1		SXOUT
	2	PD2*	MOSI1		
	3	PD3*	MISO1		
	4	PD4*	SCL1		AN16
	5	PD5*	SDA1		AN17
	6	PD6*	TXD2	I	AN18
	7	PD7*	RXD2		AN19
	8	PD8*	T6IO ⁽²⁾	WDTO	
	9	PD9*	T7IO ⁽²⁾	STBO	
	10	PD10*	AD0SOC	T0IO	
	11	PD11*	AD0EOC	T1IO	
	12	PD12*	AD1SOC	T2IO	
	13	PD13*	AD1EOC	T3IO	
	14	PD14*		SS0*	
15	PD15*		SCK0*		

^(*) mark indicates default pin setting.

⁽²⁾ mark indicates secondary port

Table 5.1. GPIO Alternative Function (Continued)

PORT		FUNCTION			
		00	01	10	11
PE	0	PE0		TXD1	
	1	PE1		RXD1	
	2	PE2		T4I(3)/T3O(5)	
	3	PE3	AD00*	SCL0*	
	4	PE4	AD10*	SDA0*	
	5	PE5*		T5IO	
	6	PE6*		T5IO ⁽²⁾	
	7	PE7*		T6IO ⁽²⁾	
	8	PE8*		T7IO ⁽²⁾	
	9	PE9*		T8IO ⁽²⁾	
	10	PE10		T9IO ⁽²⁾	
	11	PE11	T0IO ⁽²⁾	SCL1*	
	12	PE12*	T1IO ⁽²⁾	SDA1*	
	13	PE13*	T2IO ⁽²⁾	TXD2*	
	14	PE14*	T3IO ⁽²⁾	RXD2*	
	15	PE15*	T4IO ⁽²⁾		
PF	0	PF0*			
	1	PF1*			
	2	PF2*			AN20
	3	PF3*			AN21
	4	PF4*			
	5	PF5*			

^(*) mark indicates default pin setting.
⁽²⁾ mark indicates secondary port

Registers

The base address of the PCU block is 0x4000_1000.

Table 5.2. Base Address of Port

PORT	ADDRESS
PA	0x4000_1000
PB	0x4000_1100
PC	0x4000_1200
PD	0x4000_1300
PE	0x4000_1400
PF	0x4000_1500

Table 5.3. PCU Register Map

Register	Offset	R/W	Description
PCn.MR	0x--00	R/W	Port <i>n</i> pin mux select register
PCn.CR	0x--04	R/W	Port <i>n</i> pin control register
PCn.PCR	0x--08	R/W	Port <i>n</i> internal pull-up control register
PCn.DER	0x--0C	R/W	Port <i>n</i> debounce register
PCn.IER	0x--10	R/W	Port <i>n</i> interrupt enable register
PCn.ISR	0x--14	R/W	Port <i>n</i> interrupt status register
PCn.ICR	0x--18	R/W	Port <i>n</i> interrupt control register
PORTEN	0x1FF0	R/W	Port Access enable

PCA.MR Port A Pin Mux Register

The Port A Pin Mux register is the PA port mode select register. This register and the PERx and PCERx registers must be configured correctly before using the port to guarantee its functionality. PERx enables the port and PCERx enables the clock to the port.

PCA.MR=0x4000_1000

31	30	29	28	27	26	25	24	23	22	21	20	19	18	17	16	15	14	13	12	11	10	9	8	7	6	5	4	3	2	1	0
PA15	PA14	PA13	PA12	PA11	PA10	PA9	PA8	PA7	PA6	PA5	PA4	PA3	PA2	PA1	PA0																
00	00	00	00	00	00	00	00	00	00	00	00	00	00	00	00	00	00	00	00	00	00	00	00	00	00	00	00	00	00	00	00
RW	RW	RW	RW	RW	RW	RW	RW	RW	RW	RW	RW	RW	RW	RW	RW	RW	RW	RW	RW	RW	RW	RW	RW	RW	RW	RW	RW	RW	RW	RW	RW

PORT	SELECTION BIT			
	00	01	10	11
PA0	PA0			AN0
PA1	PA1			AN1
PA2	PA2			AN2
PA3	PA3			AN3
PA4	PA4		T0IO	AN4
PA5	PA5		T1IO	AN5
PA6	PA6		T2IO	AN6
PA7	PA7		T3IO	AN7
PA8	PA8			AN8
PA9	PA9			AN9
PA10	PA10			AN10
PA11	PA11			AN11
PA12	PA12	SS0		AN12
PA13	PA13	SCK0		AN13
PA14	PA14	MOSI0		AN14
PA15	PA15	MISO0		AN15

* : 2nd function

PCB.MR Port B Pin Mux Register

The Port B Pin Mux register is the PB port mode select register. This register and the PERx and PCERx registers must be configured correctly before using the port to guarantee its functionality. PERx enables the port and PCERx enables the clock to the port.

PCB.MR=0x4000_1100

31	30	29	28	27	26	25	24	23	22	21	20	19	18	17	16	15	14	13	12	11	10	9	8	7	6	5	4	3	2	1	0
PB15	PB14	PB13	PB12	PB11	PB10	PB9	PB8	PB7	PB6	PB5	PB4	PB3	PB2	PB1	PB0																
00	00	00	00	00	00	00	00	00	00	00	00	00	00	00	00	00	00	00	00	00	00	00	00	00	00	00	00	00	00	00	
RW	RW	RW	RW	RW	RW	RW	RW	RW	RW	RW	RW	RW	RW	RW	RW	RW	RW	RW	RW	RW	RW	RW	RW	RW	RW	RW	RW	RW	RW	RW	

PORT	SELECTION BIT			
	00	01	10	11
PB0	PB0	MP0UH		
PB1	PB1	MP0UL		
PB2	PB2	MP0VH		
PB3	PB3	MP0VL		
PB4	PB4	MP0WH	T9IO	
PB5	PB5	MP0WL	T9IO ⁽²⁾	
PB6	PB6	PRTIN0	WDTO ⁽²⁾	
PB7	PB7	OVIN0	STBYO ⁽²⁾	
PB8	PB8	PRTIN1	RXD3	
PB9	PB9	OVIN1	TXD3	
PB10	PB10	MP1UH		
PB11	PB11	MP1UL		
PB12	PB12	MP1VH		
PB13	PB13	MP1VL		
PB14	PB14	MP1WH		
PB15	PB15	MP1WL		

PCC.MR Port C Pin Mux Register

The Port C Pin Mux register is the PC port mode select register. This register and the PERx and PCERx registers must be configured correctly before using the port to guarantee its functionality. PERx enables the port and PCERx enables the clock to the port.

PCC.MR=0x4000_1200

31	30	29	28	27	26	25	24	23	22	21	20	19	18	17	16	15	14	13	12	11	10	9	8	7	6	5	4	3	2	1	0
PC15	PC14	PC13	PC12	PC11	PC10	PC9	PC8	PC7	PC6	PC5	PC4	PC3	PC2	PC1	PC0																
00	00	00	00	00	01	00	00	00	00	00	01	01	01	01	01																
RW	RW	RW	RW	RW	RW	RW	RW	RW	RW	RW	RW	RW	RW	RW	RW																

PORT	SELECTION BIT			
	00	01	10	11
PC0	PC0	TCK/SWCLK*	RXD0 ⁽²⁾	
PC1	PC1	TMS/SWDIO*	TXD0 ⁽²⁾	
PC2	PC2	TDO/SWO*		
PC3	PC3	TDI*		
PC4	PC4	nTRST*	T0IO ⁽²⁾	
PC5	PC5	RXD1	T1IO ⁽²⁾	
PC6	PC6	TXD1	T2IO ⁽²⁾	
PC7	PC7	SCL0	T3IO ⁽²⁾	
PC8	PC8	SDA0	T4IO ⁽²⁾	
PC9	PC9	CLKO	T8IO	
PC10	PC10	nRESET*		
PC11	PC11/BOOT*		T8IO ⁽²⁾	
PC12	PC12			XIN
PC13	PC13			XOUT
PC14	PC14	RXD0	MISO0 ⁽²⁾	
PC15	PC15	TXD0	MOSIO ⁽²⁾	

* : 2nd function

PCD.MR Port D Pin Mux Register

The Port D Pin Mux register is the PD port mode select register. This register and the PERx and PCERx registers must be configured correctly before using the port to guarantee its functionality. The PERx enables the port and PCERx enables the clock to the port.

PCD.MR=0x4000_1300

31	30	29	28	27	26	25	24	23	22	21	20	19	18	17	16	15	14	13	12	11	10	9	8	7	6	5	4	3	2	1	0
PD15	PD14	PD13	PD12	PD11	PD10	PD9	PD8	PD7	PD6	PD5	PD4	PD3	PD2	PD1	PD0																
00	00	00	00	00	00	00	00	00	00	00	00	00	00	00	00	00	00	00	00	00	00	00	00	00	00	00	00	00	00	00	00
RW	RW	RW	RW	RW	RW	RW	RW	RW	RW	RW	RW	RW	RW	RW	RW	RW	RW	RW	RW	RW	RW	RW	RW	RW	RW	RW	RW	RW	RW	RW	RW

PORT	SELECTION BIT			
	00	01	10	11
PD0	PD0	SS1		SXIN
PD1	PD1	SCK1		SXOUT
PD2	PD2	MOSI1		
PD3	PD3	MISO1		
PD4	PD4	SCL1		AN16
PD5	PD5	SDA1		AN17
PD6	PD6	TXD2		AN18
PD7	PD7	RXD2		AN19
PD8	PD8	T6IO	WDTO	
PD9	PD9	T7IO	STBO	
PD10	PD10	AD0SOC	T0IO	
PD11	PD11	AD0EOC	T1IO	
PD12	PD12	AD1SOC	T2IO	
PD13	PD13	AD1EOC	T3IO	
PD14	PD14		SS0*	
PD15	PD15		SCK0*	

* : 2nd function

PCE.MR Port E Pin Mux Register

The Port E Pin Mux register is the PE port mode select register. This register and the PERx and PCERx registers must be configured properly before using the port to guarantee its functionality. The PERx enables the port and PCERx enables the clock to the port.

PCE.MR=0x4000_1400

31	30	29	28	27	26	25	24	23	22	21	20	19	18	17	16	15	14	13	12	11	10	9	8	7	6	5	4	3	2	1	0
PE15	PE14	PE13	PE12	PE11	PE10	PE9	PE8	PE7	PE6	PE5	PE4	PE3	PE2	PE1	PE0																
00	00	00	00	00	00	00	00	00	00	00	00	00	00	00	00	00	00	00	00	00	00	00	00	00	00	00	00	00	00	00	
RW	RW	RW	RW	RW	RW	RW	RW	RW	RW	RW	RW	RW	RW	RW	RW	RW	RW	RW	RW	RW	RW	RW	RW	RW	RW	RW	RW	RW	RW	RW	

PORT	SELECTION BIT			
	00	01	10	11
PE0	PE0		TXD1	
PE1	PE1		RXD1	
PE2	PE2		T4I ⁽³⁾ /T3O ⁽⁵⁾	
PE3	PE3		SCL0*	
PE4	PE4		SDA0*	
PE5	PE5		T5IO	
PE6	PE6		T5IO ⁽²⁾	
PE7	PE7		T6IO ⁽²⁾	
PE8	PE8		T7IO ⁽²⁾	
PE9	PE9		T8IO ⁽²⁾	
PE10	PE10		T9IO ⁽²⁾	
PE11	PE11	T0IO ⁽²⁾	SCL1*	
PE12	PE12	T1IO ⁽²⁾	SDA1*	
PE13	PE13	T2IO ⁽²⁾	TXD2*	
PE14	PE14	T3IO ⁽²⁾	RXD2*	
PE15	PE15	T4IO ⁽²⁾		

* : 2nd function , ** : 3rd function

PCF.MR Port F Pin Mux Register

The Port F Pin Mux register is the PF port mode select register. This register and the PERx and PCERx registers must be configured correctly before using the port to guarantee its functionality. The PERx enables the port and PCERx enables the clock to the port.

PCF.MR=0x4000_1500

31	30	29	28	27	26	25	24	23	22	21	20	19	18	17	16	15	14	13	12	11	10	9	8	7	6	5	4	3	2	1	0
																				PF5	PF4			PF3	PF2	PF1	PF0				
00	00	00	00					00	00	00	00					00	00			00	00			00	00	00	00	00	00	00	00
																				RW	RW			RW	RW	RW	RW				

PORT	SELECTION BIT			
	00	01	10	11
PF0	PF0			
PF1	PF1			
PF2	PF2			AN20
PF3	PF3			AN21
PF4	PF4			
PF5	PF5			

PCn.CR Port n Pin Control Register (Except for PCC.CR)

The Port n Pin Control register handles the input or output control of each port pin. Each pin can be configured as input pin, output pin, or open-drain pin.

PCA.CR=0x4000_1004, PCB.CR=0x4000_1104

PCD.CR=0x4000_1304, PCE.CR=0x4000_1404, PCF.CR=0x4000_1504

31	30	29	28	27	26	25	24	23	22	21	20	19	18	17	16	15	14	13	12	11	10	9	8	7	6	5	4	3	2	1	0
P15	P14	P13	P12	P11	P10	P9	P8	P7	P6	P5	P4	P3	P2	P1	P0																
11	11	11	11	11	11	11	11	11	11	11	11	11	11	11	11	11	11	11	11	11	11	11	11	11	11	11	11	11	11	11	
RW	RW	RW	RW	RW	RW	RW	RW	RW	RW	RW	RW	RW	RW	RW	RW	RW	RW	RW	RW	RW	RW	RW	RW	RW	RW	RW	RW	RW	RW	RW	

Pn	Port control
	00 Push-pull output
	01 Open-drain output
	10 Input
	11 Analog

5.1.1 PCC.CR Port C Pin Control Register

The Port C Pin Control register handles the input or output control of each port pin. Each pin can be configured as input pin, output pin, or open-drain pin.

PCC.CR=0x4000_1204

31	30	29	28	27	26	25	24	23	22	21	20	19	18	17	16	15	14	13	12	11	10	9	8	7	6	5	4	3	2	1	0
P15	P14	P13	P12	P11	P10	P9	P8	P7	P6	P5	P4	P3	P2	P1	P0																
11	11	11	11	10	10	11	11	11	11	11	11	10	10	00	10	10	00	10	10	10	10	10	10	10	10	10	10	10	10	10	
RW	RW	RW	RW	RW	RW	RW	RW	RW	RW	RW	RW	RW	RW	RW	RW	RW	RW	RW	RW	RW	RW	RW	RW	RW	RW	RW	RW	RW	RW	RW	

Pn	Port control
	00 Push-pull output
	01 Open-drain output
	10 Input
	11 Analog

PCn.PCR Port n Pull-up Resistor Control Register

Every pin in the port has on-chip pull-up resistors which can be configured by the Port n Pull-up Resistor Control registers.

PCA.PCR=0x4000_1008, PCB.PCR=0x4000_1108, PCC.PCR=0x4000_1208

PCD.PCR=0x4000_1308, PCE.PCR=0x4000_1408, PCF.PCR=0x4000_1508

15	14	13	12	11	10	9	8	7	6	5	4	3	2	1	0
PUE15	PUE14	PUE13	PUE12	PUE11	PUE10	PUE9	PUE8	PUE7	PUE6	PUE5	PUE4	PUE3	PUE2	PUE1	PUE0
0000															
R/W															

n	PUEn	Port pull-up control
---	------	----------------------

0	Disable pull-up resistor
1	Enable pull-up resistor

PCn.DER Port n Debounce Enable Register

Every pin in the port has a digital debounce filter which can be configured by the Port n Debounce Enable registers. The Debounce clock can be configured in the DBCLKx registers in the SCU.

PCA.DER=0x4000_100C, PCB.DER=0x4000_110C, PCC.DER=0x4000_120C
 PCD.DER=0x4000_130C, PCE.DER=0x4000_140C, PCF.DER=0x4000_150C

15	14	13	12	11	10	9	8	7	6	5	4	3	2	1	0
PDE15	PDE14	PDE13	PDE12	PDE11	PDE10	PDE9	PDE8	PDE7	PDE6	PDE5	PDE4	PDE3	PDE2	PDE1	PDE0
0000															
RW															

n	PDEn	Pin debounce enable
		0 Disable debounce filter
		1 Enable debounce filter

PCn.IER Port n Interrupt Enable Register

Each individual pin can be an external interrupt source. Edge trigger interrupt and level trigger interrupt are both supported. Interrupt mode can be configured by setting the Port n Interrupt Enable registers

PCA.IER=0x4000_1010, PCB.IER=0x4000_1110, PCC.IER=0x4000_1210
 PCD.IER=0x4000_1310, PCE.IER=0x4000_1410, PCF.IER=0x4000_1510

31	30	29	28	27	26	25	24	23	22	21	20	19	18	17	16	15	14	13	12	11	10	9	8	7	6	5	4	3	2	1	0
PIE15	PIE14	PIE13	PIE12	PIE11	PIE10	PIE9	PIE8	PIE7	PIE6	PIE5	PIE4	PIE3	PIE2	PIE1	PIE0																
00	00	00	00	00	00	00	00	00	00	00	00	00	00	00	00																
RW	RW	RW	RW	RW	RW	RW	RW	RW	RW	RW	RW	RW	RW	RW	RW																

PIEn

Pin interrupt enable

00 Interrupt disabled

01 Enable interrupt as level trigger mode

10 Reserved

11 Enable interrupt as edge trigger mode

PCn.ISR Port n Interrupt Status Register

When an interrupt is delivered to the CPU, the interrupt status can be detected by reading the Port n Interrupt Status register. This register reports a source pin of interrupt and a type of interrupt.

PCA.ISR=0x4000_1014, PCB.ISR=0x4000_1114, PCC.ISR=0x4000_1214
 PCD.ISR=0x4000_1314, PCE.ISR=0x4000_1414, PCF.ISR=0x4000_1514

31	30	29	28	27	26	25	24	23	22	21	20	19	18	17	16	15	14	13	12	11	10	9	8	7	6	5	4	3	2	1	0
PIS15	PIS14	PIS13	PIS12	PIS11	PIS10	PIS9	PIS8	PIS7	PIS6	PIS5	PIS4	PIS3	PIS2	PIS1	PIS0																
00	00	00	00	00	00	00	00	00	00	00	00	00	00	00	00																
RW	RW	RW	RW	RW	RW	RW	RW	RW	RW	RW	RW	RW	RW	RW	RW																

PISn

Pin interrupt status

00 No interrupt event

01 Low level interrupt or Falling edge interrupt event is present

10 High level interrupt or rising edge interrupt event is present

11 Both of rising and falling edge interrupt event is present in edge trigger interrupt mode.

Not available in level trigger interrupt mode

PCn.ICR Port n Interrupt Control Register

The Port n Interrupt Control register is the interrupt mode control register. Edge interrupt produces a pulsed interrupt while a level interrupt maintains the interrupt as long as the pin is in the defined state (low or high).

PCA.ICR=0x4000_1018, PCB.ICR=0x4000_1118, PCC.ICR=0x4000_1218
 PCD.ICR=0x4000_1318, PCE.ICR=0x4000_1418, PCF.ICR=0x4000_1518

31	30	29	28	27	26	25	24	23	22	21	20	19	18	17	16	15	14	13	12	11	10	9	8	7	6	5	4	3	2	1	0
PIC15	PIC14	PIC13	PIC12	PIC11	PIC10	PIC9	PIC8	PIC7	PIC6	PIC5	PIC4	PIC3	PIC2	PIC1	PIC0																
00	00	00	00	00	00	00	00	00	00	00	00	00	00	00	00	00	00	00	00	00	00	00	00	00	00	00	00	00	00	00	
RW	RW	RW	RW	RW	RW	RW	RW	RW	RW	RW	RW	RW	RW	RW	RW	RW	RW	RW	RW	RW	RW	RW	RW	RW	RW	RW	RW	RW	RW	RW	

PICn	Pin interrupt mode
00	Prohibit external interrupt
01	Low level interrupt or Falling edge interrupt mode
10	High level interrupt or rising edge interrupt mode
11	Both of rising and falling edge interrupt mode. Not support for level trigger mode

PORTEN Port Access Enable

The Port Access Enable register enables register writing permission of all PCU registers.

PORTEN=0x4000_1FF0

15	14	13	12	11	10	9	8	7	6	5	4	3	2	1	0		
								PORTEN									
0	0	0	0	0	0	0	0	--									
								WO									

7	PORTEN	Writing the sequence of 0x15 and 0x51 in this register enables writing to PCU registers, and writing other values protects all PCU registers from writing.
0		

Functional Description

All the GPIO pins can be configured for different operations, inputs, outputs, triggered interrupts (both level and edge) through the PCU. The system is also able to disable ports by setting the PER1 and PCER1 registers in the SCU. By default, all pins are disabled (except for UART0/SPI0) so the developer must enable these to operate.

All configuration parameters are protected by the Port Access Enable register. You must write the sequence in order (0x15, 0x51) to the PORTEN register to configure any pin(s). After the configuration is complete, write any other value to the PORTEN register to lock it.

Note: Do not read in between the sequence, that will prevent the configuration registers from being unlocked.

6. General Purpose I/O

Overview

Most of the pins except the dedicated function pins can be used as general I/O ports. General input/output ports are controlled by the GPIO block.

- Output signal level (H/L) select

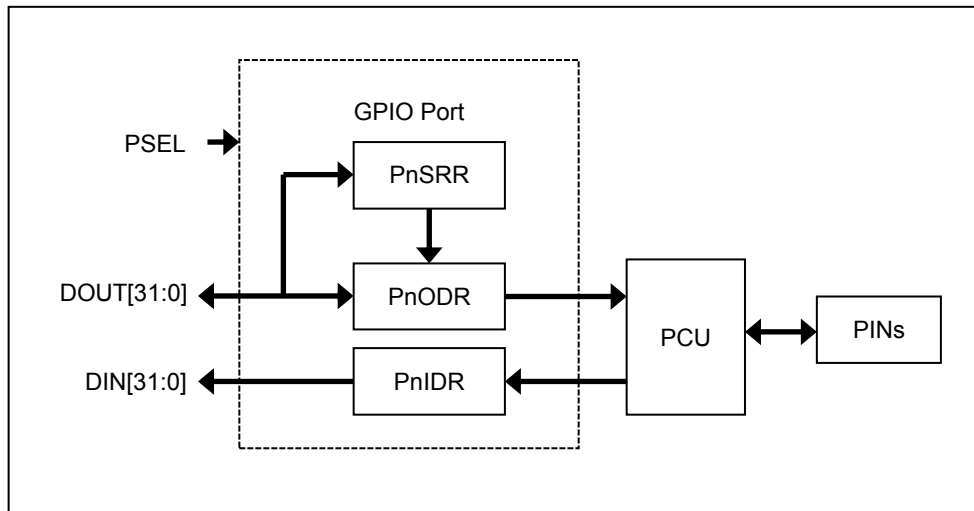

Figure 6.1. Block Diagram

Pin Description

Table 6.1. External Signal

PIN NAME	TYPE	DESCRIPTION
PA	IO	PA0 - PA15
PB	IO	PB0 - PB15
PC	IO	PC0 - PC15
PD	IO	PD0 - PD15
PE	IO	PE0 – PE15
PF	IO	PF0 – PF5

Registers

The base address of GPIO is 0x4000_2000 and the register map is described in Tables 6.2 and 6.3.

Table 6.2. Base Address of Each Port

PORT	Address
PA PORT	0x4000_2000
PB PORT	0x4000_2100
PC PORT	0x4000_2200
PD PORT	0x4000_2300
PE PORT	0x4000_2400
PF PORT	0x4000_2500

Table 6.3. GPIO Register Map

Name	Offset	R/W	Description	Reset
Pn.ODR	0x--00	R/W	Port <i>n</i> Output data register	0x00000000
Pn.IDR	0x--04	RO	Port <i>n</i> Input data register	0x00000000
Pn.BSR	0x--08	WO	Port <i>n</i> Pin set register	0x00000000
Pn.BCR	0x--0C	WO	Port <i>n</i> Pin clear register	0x00000000

Pn.ODR Port n Output Data Register

When the pin is set to output and GPIO mode, the pin output level is defined by the Port n Output Data registers.

PA.ODR=0x4000_2000, PB.ODR=0x4000_2100, PC.ODR=0x4000_2200
 PD.ODR=0x4000_2300, PE.ODR=0x4000_2400, PF.ODR=0x4000_2500

15	14	13	12	11	10	9	8	7	6	5	4	3	2	1	0
ODR															
0000															
R/W															

ODR Pin output level
 0 Output low level
 1 Output high level

Pn.IDR Port n Input Data Register

Each pin level status can be read in the Port n Input Data register. Even if the pin is in alternative mode except analog mode, the pin level can be detected in this register.

PA.IDR=0x4000_2004, PB.IDR=0x4000_2104, PC.IDR=0x4000_2204
 PD.IDR=0x4000_2304, PE.IDR=0x4000_2404, PF.IDR=0x4000_2504

15	14	13	12	11	10	9	8	7	6	5	4	3	2	1	0
PnIDR															
0000															
Read Only															

IDR Pin current level
 0 The pin is low level
 1 The pin is high level

Pn.BSR Port n Bit Set Register

The Port n Bit Set register controls each bit of of the Port n Output Data register (PnODR). When you write “1” to a specific bit, the corresponding bit in the PnODR register is set.

PA.BSR=0x4000_2008, PB.BSR=0x4000_2108, PC.BSR=0x4000_2208
 PD.BSR=0x4000_2308, PE.BSR=0x4000_2408, PF.BSR=0x4000_2508

15	14	13	12	11	10	9	8	7	6	5	4	3	2	1	0
BSR															
0000															
Write Only															

BSR Pin current level
 0 Not effect
 1 Set correspondent bit in PnODR register

Pn.BCR Port n Bit Clear Register

The Port n Bit Clear register controls each bit of the Port n Output Data register (PnODR). When you write “1” to a specific bit, the corresponding bit in the PnODR register is cleared.

PA.BCR=0x4000_200C, PB.BCR=0x4000_210C, PC.BCR=0x4000_220C
 PD.BCR=0x4000_230C, PE.BCR=0x4000_240C, PF.BCR=0x4000_250C

15	14	13	12	11	10	9	8	7	6	5	4	3	2	1	0
BCR															
0000															
Write Only															

BCR

Pin current level

0 Not effect

1 Clear correspondent bit in PnODR register

Functional Description

The GPIO registers provide the input/output condition of the GPIO pins. The input data registers give the states of the pins of the ports. The output data register is for setting the port pins. The Set and Clear registers control the pins at the individual level.

7. Flash Memory Controller

Introduction

Flash Memory Controller is an internal Flash memory interface controller with the following features:

- 384KB Flash code memory
- 32-bit data bus width
- Code cache block for fast access mode
- 256-byte page size
- Supports page erase and macro erase
- 256-byte unit program

Item	Description
Size	384KB
Start Address	0x0000_0000
End Address	0x0005_FFFF
Page Size	256-byte
Total Page Count	1,536 pages
PGM Unit	256-byte
Erase Unit	256-byte

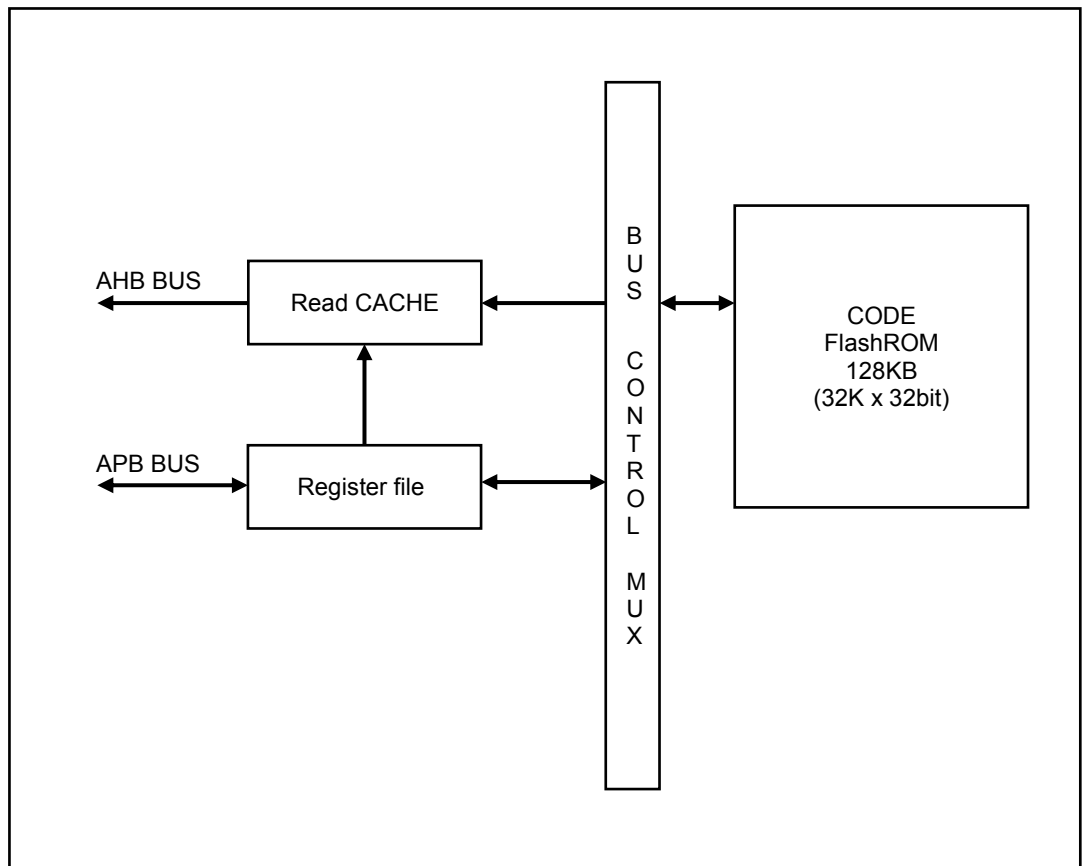

Figure 7.1. Block Diagram

Pin Description

There are no external interface pins for this peripheral.

Registers

The base address of the Flash Memory Controller is shown in Table 7.1.

Table 7.1. Flash Memory Controller Base Address

	Address
Flash Controller	0x4000_0100

Table 7.2 shows the register memory map.

Table 7.2. Flash Memory Controller Register Map

Name	Offset	R/W	Description	Reset
FM.MR	0x0004	R/W	Flash Memory Mode Select register	0x01000000
FM.CR	0x0008	R/W	Flash Memory Control register	0x82000000
FM.AR	0x000C	R/W	Flash Memory Address register	0x00000000
FM.DR	0x0010	R/W	Flash Memory Data register	0x00000000
FM.TMR	0x0014	R/W	Flash Memory Timer register	0x000000bb
FM.DRTY	0x0018	R/W	Flash Memory Dirty bit	
FM.TICK	0x001C	RO	Flash Memory Tick Timer	0x00000000
FM.CRC	0x0020	RO	Flash Memory Read CRC Value	
FM.CFG	0x0030	R/W	Flash Memory config value register	0x00000000
FM.OTPCR	0x0034	R/W	Flash OTP control register	0x00000000
FM.BOOTCR	0x0074	R/W	Boot ROM Remap Clear register	0x00000000
FM.PROT	0x0078	R/W	Flash Page protection register	0x00000000
FM.JTAGEN	0x007C	R/W	Jtag protection register	0x00000001

FM.MR Flash Memory Mode Register

The Internal Flash Memory Mode register is a 32-bit register.

FM.MR=0x4000_0104

31	30	29	28	27	26	25	24	23	22	21	20	19	18	17	16	15	14	13	12	11	10	9	8	7	6	5	4	3	2	1	0			
BOOT								IDLE	VERIFY	AMBAEN							TRMEN	TRM							FEMOD	FMOD	ACODE							
0								1	0	0	0	0	0	0	0	0	0	0	0	0	0	0	0	0	0	0	0	0x00						
R								R	RW	RW							R	R							R	R	RW							

31	BOOT	0	
		1	Boot mode enable status(read only)
24	IDLE	0	
		1	Boot mode enable status(read only)
23	VERIFY	0	
		1	Flash Verify mode enable status(read only)
22	AMBAEN	0	AMBA mode disable
		1	AMBA mode enable (can change wait state and etc)
17	TRMEN	0	
		1	Trim mode entry status(read only)
16	TRM	0	
		1	Trim mode status(read only)
9	FEMOD	0	
		1	Flash mode entry status(read only)
8	FMOD	0	
		1	Flash mode status(read only)
7	ACODE	5A → A5	Flash mode
0		A5 → 5A	Trim mode
		81 → 28	AMBA mode

FM.CR Flash Memory Control Register

The Internal Flash Memory Control register is shown below.

FM.CR=0x4000_0108

31	30	29	28	27	26	25	24	23	22	21	20	19	18	17	16	15	14	13	12	11	10	9	8	7	6	5	4	3	2	1	0	
											TIMER			TEST1	TEST0	VPPOUT	EVER	PVER	RESERVED	RESERVED	RESERVED	PPGM	AE				PMOD	WE	PBLD	PGM	ERS	PBR
0	0	0	0	0	0	0	0	0	0	0	0	0	0	0	0	0	0	0	0	0	0	0	0	0	0	0	0	0	0	0	0	
RW	RW	RW	RW	RW		RW	RW	RW	RW		RW			RW	RW	R	RW	RW				RO	RW	RW			RW	RW	RW	RW	RW	RW

											1																											
20	TIMER										0																											
												1																										
17	TEST[1:0]										00																											
16											01																											
											01																											
											10																											
											11																											
15	VPPOUT																																					
14	EVER																																					
13	PVER																																					
12	RESERVED																																					
11	RESERVED																																					
10	RESERVED																																					
9	PPGM																																					
8	AE																																					
5	PMODE																																					
4	WE																																					
3	PBLD																																					
2	PGM																																					
1	ERS																																					
0	PBR																																					

FM.AR Flash Memory Address Register

The Flash Memory Address register is the internal Flash Memory program/erase address register.

FM.AR=0x4000_010C

16	15	14	13	12	11	10	9	8	7	6	5	4	3	2	1	0
FADDR																
0																
0x0000																
RW																

16	FADDR	96K words address (one word = 4 bytes)
0		

FM.DR Flash Memory Data Register

The Internal Flash Memory Data register is shown below.

FM.DR=0x4000_0110

31	30	29	28	27	26	25	24	23	22	21	20	19	18	17	16	15	14	13	12	11	10	9	8	7	6	5	4	3	2	1	0		
FDATA																																	
0x0000_0000																																	
RW																																	

31	FDATA	Flash PGM data (32-bit)
0		

FM.TMR Flash Memory Timer Register

In the internal Flash Memory Timer value register (16-bit), the Erase/Program timer runs up to {TMR[15:0]}.

FM.TMR=0x4000_0114

15	14	13	12	11	10	9	8	7	6	5	4	3	2	1	0
TMR															
0x09C4															
RW															

15	TMR	Erase/PGM timer (default, 0x09C4) Timer counts up to TMR[15:0] by int. OSC clock or External OSC clock. It can be selected in TMRCK bit.
0		

FM.DRTY Flash Memory Dirty Bit Register

The internal Flash Memory Dirty Bit clear register is shown below.

FM.DRTY=0x4000_0118

31	30	29	28	27	26	25	24	23	22	21	20	19	18	17	16	15	14	13	12	11	10	9	8	7	6	5	4	3	2	1	0
FDRTY																															
-																															
Write Only																															

31	FDRTY	Write any value here, cache line fill flag will be cleared.
0		

FM.TICK Flash Memory Tick Timer Register

The Flash Memory Tick Timer register is the internal Flash Memory Burst Mode channel selection register.

FM.TICK=0x4000_011C

31	30	29	28	27	26	25	24	23	22	21	20	19	18	17	16	15	14	13	12	11	10	9	8	7	6	5	4	3	2	1	0
																FTICK															
0								0								0x00000															
RW																															

17	FTICK	TICK goes to 0x3FFFF from written TICK value while TRM runs by PCLK clock
0		

FM.CRC Flash Memory CRC Value Register

The Flash Memory CRC Value register shows the CRC value resulting from read accesses on internal Flash memory.

FM.CRC=0x4000_0120

31	30	29	28	27	26	25	24	23	22	21	20	19	18	17	16	15	14	13	12	11	10	9	8	7	6	5	4	3	2	1	0
																CRC															
0								0								0xFFFF															
RO																															

15	CRC	CRC16 value
0		

FM.CFG Flash Memory Config Value Register

The Flash Memory Config Value register is the Flash Trim value register.

FM.CFG=0x4000_0130

31	30	29	28	27	26	25	24	23	22	21	20	19	18	17	16	15	14	13	12	11	10	9	8	7	6	5	4	3	2	1	0			
WRITE KEY																HRESPD			TMRCK				WAIT			CRCINIT	CRCEN					TRIM		
0	0	0	0	0	0	0	0	0	0	0	0	0	0	0	0	1				0			1	1	0	0					0			
																																0		
																																		R/W

31	WRITE KEY		KEY Value : 0x7858
15	HRESPD		Disable HRESP(error response function) of Data or System bus (HRESP is AMBA AHB signal)
12	TMRCK	0	PGM/ERASE timer source is 20MHz INTOSC
		1	PRM/ERASE timer source is External Clock
10	WAIT	000	No wait access for flash memory
8		001	1-wait inserted for flash access
		010	2-wait inserted for flash access
		011	3-wait inserted for flash access
		100	4-wait inserted for flash access
		101	5-wait inserted for flash access
7	CRCINIT	0	CRC register will be initialized. It should be reset again before read flash to generate CRC16 calculation (Initial value of FMCRC is 0xFFFF)
		1	
6	CRCEN	0	CRC16 enable
		1	CRC value will be calculated at every flash read timing
3	TRIM		FLASH TRIM Value (trim_mode_entry)
0			

FM.BOOTCR Boot ROM Remap Clear Register

The Boot ROM Remap Clear register is an 8-bit register.

FM.BOOTCR=0x4000_0174

7	6	5	4	3	2	1	0
							BOOTROM
0	0	0	0	0	0	0	1
							R

0	BOOTROM	Boot Mode (only can be written in boot loader mode) This bit is used to clear boot loader mode at end of boot code (when BOOTROM low, external BOOT pin signal is masked)
---	---------	--

FM.JTAGEN JTAG Protection Control Register

The JTAG Protection Control register is the debug access control register.

FM.JTAGEN=0x4000_017C

31	30	29	28	27	26	25	24	23	22	21	20	19	18	17	16	15	14	13	12	11	10	9	8	7	6	5	4	3	2	1	0
WRITE_KEY																								JTAGEN							
0 0 0 0 0 0 0 0								0 0 0 0 0 0 0 0								0 0 0 0 0 0 0 0								0 0 0 0 0 0 0 1							
																								RW							

0	JTAGEN	0	Debug access port is disabled, write access code is 0xC7
1		1	Debug access port is enabled

FM.PROT Write Protection Control Register

The Write Protection Control register is the internal Flash memory control register. The PAS selects the area to protect and the WP bits specify the section within the area.

FM.PROTECT=0x4000_0178

31	30	29	28	27	26	25	24	23	22	21	20	19	18	17	16	15	14	13	12	11	10	9	8	7	6	5	4	3	2	1	0	
WRITE_KEY								APR					PAS	WP15	WP14	WP13	WP12	WP11	WP10	WP9	WP8	WP7	WP6	WP5	WP4	WP3	WP2	WP1	WP0			
0 0 0 0 0 0 0 0								0	0	0	0	0	0	0x0	0	0	0	0	0	0	0	0	0	0	0	0	0	0	0	0	0	0
								RW					RW	R/W	RW	RW	RW	RW	RW	RW	RW	RW	RW	RW	RW	RW	RW	RW	RW	RW		

23	APR	All protection removed, write_key is 0xA9
0x0 : protection enabled (default)		
0x1 : removed All protection , WP15~0 will be set as APR set		
18	PAS	Protection Area Selction, write_key is 0x98
16		0x0 : protection area < 64KB
		0x1 : 64KB < protection area < 128KB
		0x2 : 128KB < protection area < 192KB
		0x3 : 192KB < protection area < 256KB
		0x4 : 256KB < protection area < 320KB
		0x5 : 320KB < protection area < 384KB
15	WP15	0xF000 ~ 0xFFFF, write_key is 0x87 or 0x98
14	WP14	0xE000 ~ 0xEFFF, write_key is 0x87 or 0x98
13	WP13	0xD000 ~ 0xDFFF, write_key is 0x87 or 0x98
12	WP12	0xC000 ~ 0xCFFF, write_key is 0x87 or 0x98
11	WP11	0xB000 ~ 0xBFFF, write_key is 0x87 or 0x98
10	WP10	0xA000 ~ 0xAFFF, write_key is 0x87 or 0x98
9	WP9	0x9000 ~ 0x9FFF, write_key is 0x87 or 0x98
8	WP8	0x8000 ~ 0x8FFF, write_key is 0x87 or 0x98
7	WP7	0x7000 ~ 0x7FFF, write_key is 0x87 or 0x98
6	WP6	0x6000 ~ 0x6FFF, write_key is 0x87 or 0x98
5	WP5	0x5000 ~ 0x5FFF, write_key is 0x87 or 0x98
4	WP4	0x4000 ~ 0x4FFF, write_key is 0x87 or 0x98

3	WP3	0x3000 ~ 0x3FFF, write_key is 0x87 or 0x98
2	WP2	0x2000 ~ 0x2FFF, write_key is 0x87 or 0x98
1	WP1	0x1000 ~ 0x1FFF, write_key is 0x87 or 0x98
0	WP0	0x0000 ~ 0x0FFF, write_key is 0x97 or 0x98
		0x0 : Protected (default)
		0x1 : PGM/ERASE enabled

Functional Description

The Flash area can be read from directly via the memory address. Writing of Flash memory can be done through the Boot mode or In-application programming. The execution for the writing of Flash must occur from the RAM area (or from Boot ROM). The Flash controller cannot read Flash memory (including instructions) once the program bit has been set.

Caution: If the vector table is not placed in RAM, you MUST disable interrupts to prevent reading the interrupt service routine in Flash memory.

8. Internal SRAM

Overview

The Z32F384 MCU implements zero-wait on the chip's SRAM. The size of the SRAM is 16 KB. The SRAM base address is 0x2000_0000.

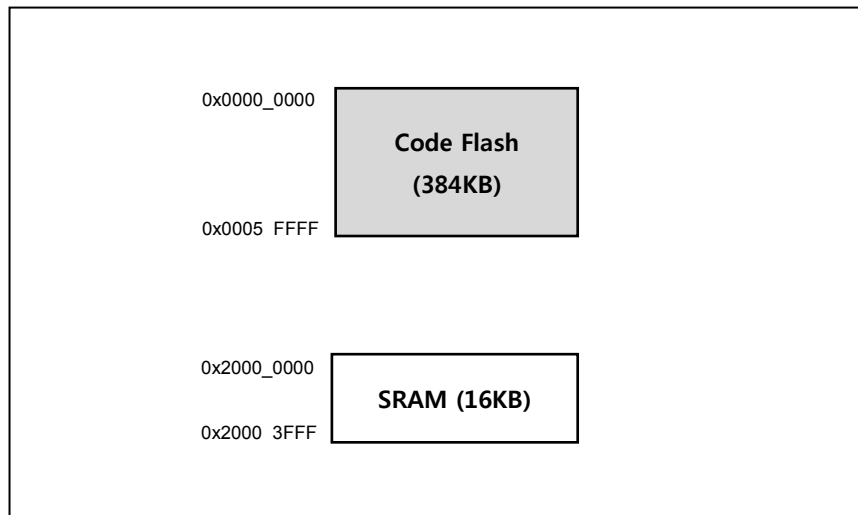

Figure 8.1. SRAM Block Diagram

9. Direct Memory Access Controller

Introduction

The Direct Memory Access (DMA) controller has the following features:

- 8 channels
- Single transfer only
- Supports 8-/16-/32-bit data size
- Supports multiple buffers with same size
- Interrupt condition is transferred through peripheral interrupt

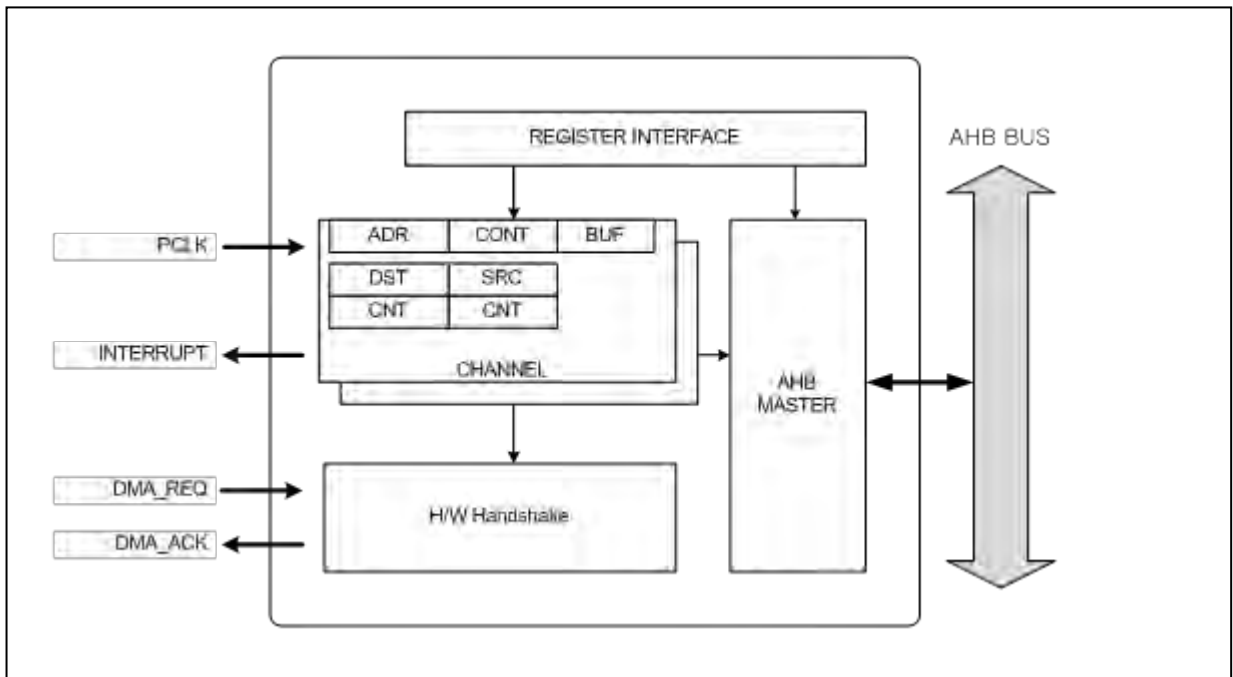

Figure 9.1. Block Diagram

Pin Description

There are no external interface pins.

Registers

The base addresses of the DMA controller are shown in Table 9.1.

Table 9.1. DMA Controller Base Addresses

Ch. No.	Base Address	Assigned Peripheral
DMACH0	0x4000_0400	
DMACH1	0x4000_0410	
DMACH2	0x4000_0420	
DMACH3	0x4000_0430	
DMACH4	0x4000_0440	
DMACH5	0x4000_0450	
DMACH6	0x4000_0460	
DMACH7	0x4000_0470	

Table 9.2 shows the register map of the DMA controller.

Table 9.2. DMAC Register Map

Name	Offset	R/W	Description	Reset
DCn.CR	0x0000	R/W	DMA Channel n Control Register	0x0000_0000
DCn.SR	0x0004	R/W	DMA Channel n Status Register	0x0000_0000
DCn.PAR	0x0008	R	DMA Channel n Peripheral Address	0x0000_0000
DCn.MAR	0x000C	R/W	DMA Channel n Memory Address	0x2000_0000

DCn.CR DMA Controller Configuration Register

The DMA operation control register is a 32-bit register.

DC0.CR=0x4000_0400 , DC1.CR=0x4000_0410
 DC2.CR=0x4000_0420 , DC3.CR=0x4000_0430
 DC4.CR=0x4000_0440 , DC5.CR=0x4000_0450
 DC6.CR=0x4000_0460 , DC7.CR=0x4000_0470

31	30	29	28	27	26	25	24	23	22	21	20	19	18	17	16	15	14	13	12	11	10	9	8	7	6	5	4	3	2	1	0
TRANSCNT								PERISEL								SIZE		DIR													
0	0	0	0					0x000								0	0	0	0	0	0	0	0	00	0	0					
RW								RW								RW		R/W													

27	TRANSCNT	Number of DMA transfer remained
16		Required transfer number should be written before enable DMA transfer.
		0 DMA transfer is done.
		N N transfers are remained
11	PERISEL	Peripheral selction
8		N Associated peripheral selection. Refer to DMA Peripheral connection table
3	SIZE	Bus transfer size.
2		00 DMA transfer is byte size transfer
		01 DMA transfer is half word size transfer
		10 DMA transfer is word size transfer
		11 Reserved
1	DIR	Select transfer direction.
		0 Transfer direction is from memory to peripheral. (TX)
		1 Transfer direction is from peripheral to memory (RX)

A DMA channel is connected with the selected peripheral.

Table 9.3 sTable 9.3. DMAC PERISEL Selectionhows peripheral selection numbers. The PERISEL field should be set with the correct number of the peripheral which will be connected with the DMA interface.

Table 9.3. DMAC PERISEL Selection

PERISEL[3:0]	Associated Peripheral
0	CHANNEL IDLE
1	UART0 RX
2	UART0 TX
3	UART1 RX
4	UART1 TX
5	UART2 RX
6	UART2 TX
7	UART3 RX
8	UART3 TX
9	SPI0 RX
10	SPI0 TX
11	SPI1 RX
12	SPI1 TX
13	ADC0 RX
14	ADC1 RX

PERISEL cannot have the same value in different channels. If the same PERISEL value is written in more than one channel, proper operation is not guaranteed.

Unused channels should contain a CHANNEL IDLE value in the PERISEL bit positions.

DCn.SR DMA Controller Status Register

The DMA Controller Status register is an 8-bit register. This register represents the current status of DMA Controller and enables DMA function.

DC0.SR=0x4000_0404 , DC1.SR=0x4000_0414
 DC2.SR=0x4000_0424 , DC3.SR=0x4000_0434
 DC4.SR=0x4000_0444 , DC5.SR=0x4000_0454
 DC6.SR=0x4000_0464 , DC7.SR=0x4000_0474

7	6	5	4	3	2	1	0
EOT							DMAEN
1	0	0	0	0	0	0	0
RO							R/W

7	EOT	End of transfer. 0 Data to be transferred is existing. TRANSCNT shows non zero value 1 All data is transferred. TRANSCNT shows now 0
0	DMAEN	DMA Enable 0 DMA is in stop or hold state 1 DMA is running or enabled

DCn.PAR DMA Controller Peripheral Address Register

The DMA Controller Peripheral Address register represents the peripheral address.

DC0.PAR=0x4000_0408 , DC1.PAR=0x4000_0418
 DC2.PAR=0x4000_0428 , DC3.PAR=0x4000_0438
 DC4.PAR=0x4000_0448 , DC5.PAR=0x4000_0458
 DC6.PAR=0x4000_0468 , DC7.PAR=0x4000_0478

31	30	29	28	27	26	25	24	23	22	21	20	19	18	17	16	15	14	13	12	11	10	9	8	7	6	5	4	3	2	1	0
Peripheral BASE OFFSET																PAR															
0x4000																0x0000															
RO																RW															

31	PAR	Target Peripheral address of transmit buffer or receive buffer.
0		User must set exact target peripheral buffer address in this field.
		If DIR is "0" this address is destination address of data transfer.
		If DIR is "1", this address is source address of data transfer.

DCn.MAR DMA Controller Memory Address Register

The DMA Controller Memory Address register represents the memory address.

DC0.MAR=0x4000_040C , DC1.MAR=0x4000_041C
 DC2.MAR=0x4000_042C , DC3.MAR=0x4000_043C
 DC4.MAR=0x4000_044C , DC5.MAR=0x4000_045C
 DC6.MAR=0x4000_046C , DC7.MAR=0x4000_047C

31	30	29	28	27	26	25	24	23	22	21	20	19	18	17	16	15	14	13	12	11	10	9	8	7	6	5	4	3	2	1	0
																MAR															
0x2000																0x0000															
RO																RW															

31	MAR	Target memory address of data transfer.
0		Address is automatically incremented according to SIZE bits when each transfer is done.
		If DIR is "0" this address is source address of data transfer.
		If DIR is "1", this address is destination address of data transfer.

Functional Description

The DMA controller performs direct memory transfer by sharing the system bus with the CPU core. The system bus is shared by two AHB masters following the round-robin priority strategy. Therefore, the DMA controller can share half of the system bandwidth.

The DMA controller can be triggered only by a peripheral request. When a peripheral requests a transfer to the DMA controller, the related channel is activated and accesses the bus to transfer the requested data from memory to the peripheral data buffer or vice versa.

The transfer process involves the following steps:

1. User sets the peripheral and memory addresses.
2. User configures DMA operation DST mode and transfer count.
3. User enables the DMA channel.
4. Peripheral generates a DMA request.
5. DMA activates the channel that was requested
6. DMA reads data from the source address and saves it to the internal buffer.
7. DMA writes the buffered data to the destination address.
8. Transfer count number is decreased by 1.
9. When the transfer count is 0, the EOT flag is set and notice is sent to the peripheral to issue the interrupt.
10. DMA does not have an interrupt source; the interrupt-related DMA status can be shown from the assigned peripheral interrupt.

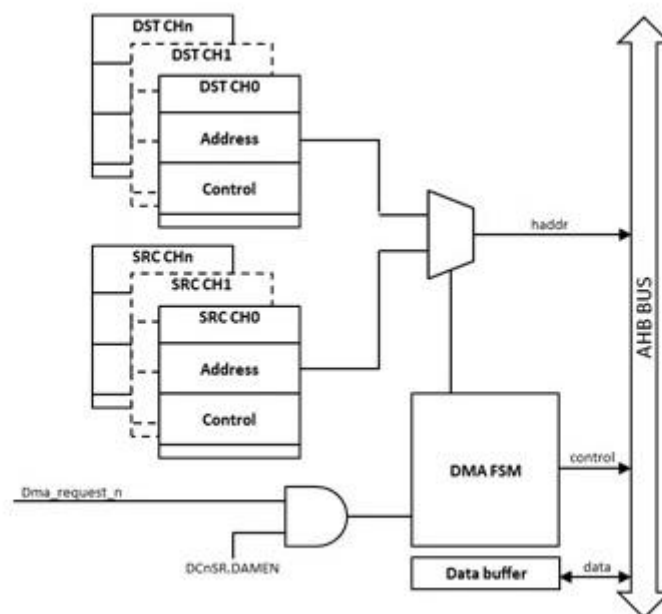

Figure 9.2. Block Diagram

Figure 9.3 The figure shows the functional timing diagram of the DMA controller. The transfer request from the peripheral is pended internally and it invokes source data read transfer on the AHB bus. The read data from the source address is stored in the internal buffer. This data is transferred to the destination address when the AHB bus is available.

The timing diagram for a DMA transfer from the peripheral to memory is shown in Figure 9.3. A 4-clock cycle latency exists when accessing the peripheral. If the bus is occupied by a different bus master, the number of bus waiting cycles increase until the bus is available.

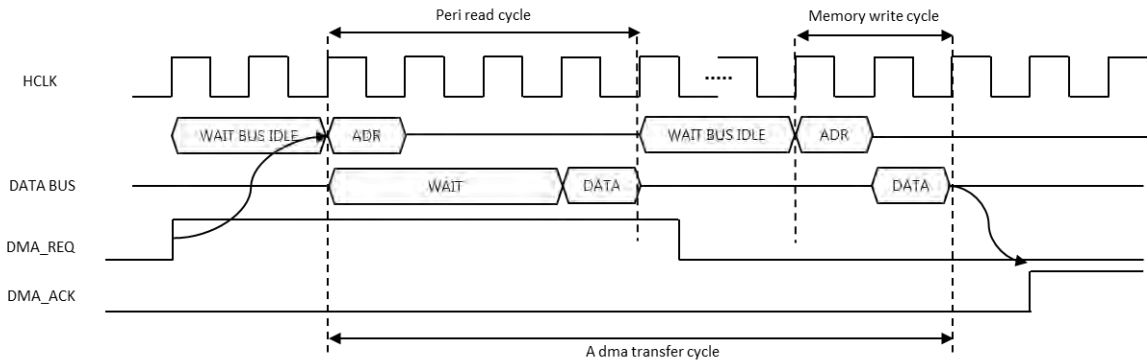

Figure 9.3. DMA Transfer from Peripheral to Memory

The timing diagram for a DMA transfer from memory to the peripheral is shown in Figure 9.4. A 4-clock cycle latency exists when accessing the peripheral. If the bus is occupied by a different bus master, the number of bus waiting cycles increase until the bus is available.

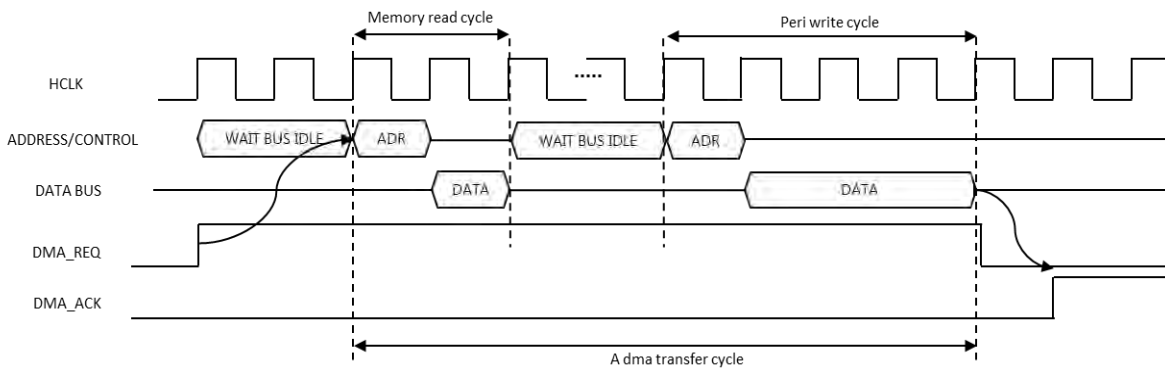

Figure 9.4. DMA Transfer from Memory to Peripheral

Figure 9.5 is an example of N data transfers with the DMA. The DMA transfer is started when DCnSR.DMAEN is set and cleared when all the transfers are completed.

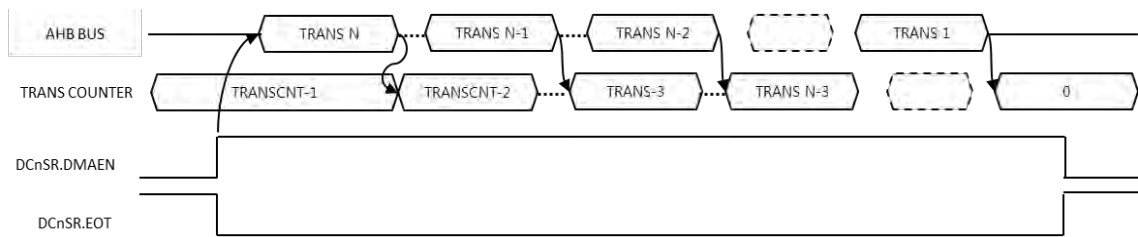

Figure 9.5. Example of N DMA Transfer

10. Watch-Dog Timer

Overview

The Watchdog Timer can monitor the system and generate an interrupt or a reset. It has a 32-bit down-counter. Miscellaneous Clock Control Register 3 provides base clock options with clock dividers to drive the WDT clock. This can be selected in the WDTCON register. To prevent the WDT from firing, reload the LR register with the appropriate value before the WDT times out.

- 32-bit down counter (WDCNT)
- Select reset or periodic interrupt
- Count clock selection
- Dedicated pre-scaler
- Watchdog overflow output signal

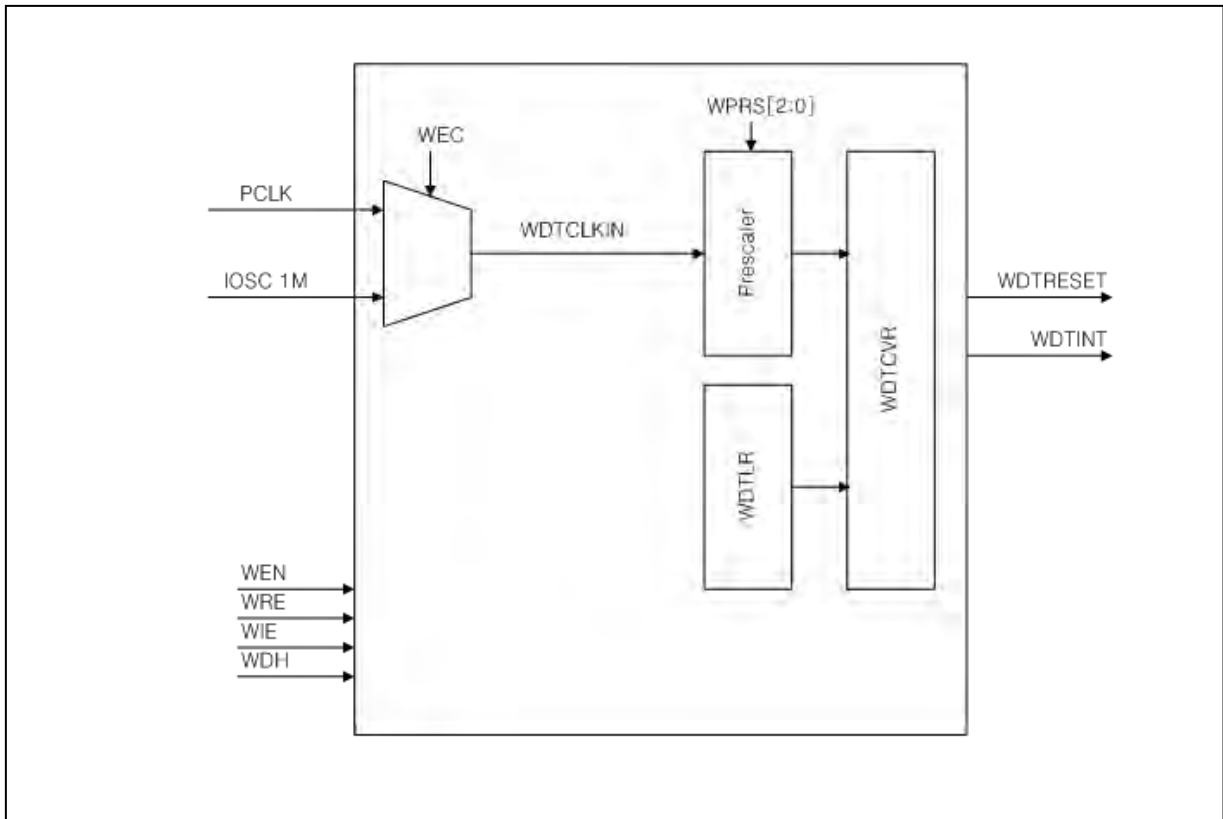

Figure 10.1. Block Diagram

Registers

The base address of the watchdog timer is 0x4000_0200 and the register map is listed in Table 10.1. Initial watchdog time-out period is set to 2000-milliseconds.

Table 10.1. Watchdog Timer Register Map

Name	Offset	R/W	Description	Reset
WDT.LR	0x0000	W	WDT Load register	0x00000000
WDT.CNT	0x0004	R	WDT Current counter register	0x0000FFFF
WDT.CON	0x0008	R/W	WDT Control register	0x0000805C

WDT.LR Watchdog Timer Load Register

The Watchdog Timer Load register is used to update the WDTCNT register. To update the WDTCNT register, the WEN bit of WDTCON should be set to 1 and written into the WDTLR register with a target value of WDTCNT.

WDT.LR=0x4000_0200

31	30	29	28	27	26	25	24	23	22	21	20	19	18	17	16	15	14	13	12	11	10	9	8	7	6	5	4	3	2	1	0
WDTLR																															
0x0000_0000																															
RW																															
31	WDTLR		Watchdog timer load value register																												
0	Keeping WEN bit as '1', write WDTLR register will update WDTCNT value with written value																														

WDT.CNT Watchdog Timer Current Counter Register

The Watchdog Timer Current Counter register represents the current count value of the 32-bit down counter. When the counter value reaches 0, the interrupt or reset is awoken.

WDT.CNT=0x4000_0204

31	30	29	28	27	26	25	24	23	22	21	20	19	18	17	16	15	14	13	12	11	10	9	8	7	6	5	4	3	2	1	0
WDTCNT																															
0x0000_FFFF																															
RW																															
31	WDTCNT		Watchdog timer current counter register																												
0	32-bit down counter will run from the written value.																														

WDT.CON Watchdog Timer Control Register

The timer module should be correctly configured before running. When the target purpose is defined, the timer can be configured in the TnCON register.

WDT.CON=0x4000_0208

15	14	13	12	11	10	9	8	7	6	5	4	3	2	1	0
WDBG							WUF	WDTIE	WDTRE		WDTEN	CKSEL			WPRS
1	0	0	0	0	0	0	0	0	1	0	1	1			100
RW							RW	RW	RW		RW	RW			RW

15	WDBG	Watchdog operation control in debug mode
		0 Watchdog counter running when debug mode
		1 Watchdog counter stopped when debug mode
8	WUF	Watchdog timer underflow flag
		0 No underflow
		1 Underflow is pending
7	WDTIE	Watchdog timer counter underflow interrupt enable
		0 Disable interrupt
		1 Enable interrupt
6	WDTRE	Watchdog timer counter underflow interrupt enable
		0 Disable reset
		1 Enable reset
4	WDTEN	Watchdog Counter enable
		0 Watch dog counter disabled
		1 Watch dog counter enabled
3	CKSEL	WDTCLKIN clock source select
		0 PCLK
		1 External clock (Configured in MCCR3)
2	WPRS[2:0]	Counter clock prescaler
0		WDTCLK = WDTCLKIN/WPRS
		000 WDTCLKIN / 1
		001 WDTCLKIN / 4
		010 WDTCLKIN / 8
		011 WDTCLKIN / 16
		100 WDTCLKIN / 32
		101 WDTCLKIN / 64
		110 WDTCLKIN / 128
		111 WDTCLKIN / 256

Functional Description

The MCCR3 register must be configured to enable the clock source and divider for the Watch Dog Timer (WDT) to run. To prevent the WDT from resetting or interrupting, load a new value into the WDTLR register before the WDTCNT reaches 0.

The watchdog timer count is enabled by setting WDTEN (WDT.CON[4]) to 1. When the watchdog timer is enabled, the down counter starts counting from the load value. If WDTRE (WDT.CON[6]) is set to 1, WDT reset is asserted when the WDT counter value reaches 0 (underflow event) from the WDTLR value. Before the WDT counter goes down to 0, the software can write a certain value to the WDTLR register to reload the WDT counter.

Timing Diagram

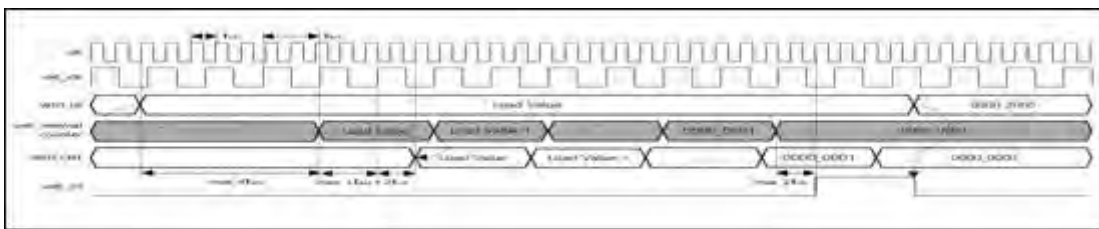

Figure 10.2. Timing Diagram in Interrupt Mode Operation when WDT Clock is External Clock

In WDT interrupt mode, after the WDT underflow occurs, a certain count value is reloaded to prevent the next WDT interrupt in a short time period. This reloading action can only be activated when the watchdog timer counter is set to Interrupt mode (set WDTIE of WDT.CON). It takes up to 5 cycles from the load value to the CNT value. The WDT interrupt signal and CNT value data might be delayed by a maximum of 2 system bus clocks in synchronous logic.

Prescale Table

The WDT includes a 32-bit down counter with programmable prescaler to define different time-out intervals.

The clock sources of the watchdog timer can include the peripheral clock (PCLK) or one of 3 external clock sources. An external clock source can be enabled by CKSEL (WDT.CON[3]) set to '1' and external clock source chosen in MCCR3 register of the System Control Unit block.

To make the WDT counter base clock, users can control the 3-bit prescaler WPRS [2:0] in the WDT.CON register and the maximum prescaled value is "clock source frequency/256". The prescaled WDT counter clock frequency values are listed in Table 10.2.

Selectable clock source (40 kHz ~ 16 MHz) and the time out interval when 1 count

$$\text{Time out period} = \{(\text{Load Value}) * (1/\text{pre-scaled WDT counter clock frequency}) + \max 5T_{\text{ext}}\} + \max 4T_{\text{clk}}$$

*Time out period (time out period from load Value to interrupt set '1')

Table 10.2. Prescaled WDT Counter Clock Frequency

Clock Source	WDTCLKIN	WDTCLKIN/4	WDTCLKI N/8	WDTCLKIN/16	WDTCLKI N/32	WDTCLKI N/64	WDTCLKI N/128	WDTCLKI N/256
Ring OSC	1MHz	250kHz	125kHz	62.5kHz	31.25kHz	15.625kHz	7.8125kHz	3.90625kHz
MCLK	MCLK (BUS CLK)	MCLK/4	MCLK/8	MCLK/16	MCLK/32	MCLK/64	MCLK/128	MCLK/256
IOSC20	20MHz	5MHz	2.5MHz	1.25MHz	625kHz	312.5kHz	156.25kHz	78.125kHz
EOSC	XTAL	XTAL/4	XTAL/8	XTAL/16	XTAL/32	XTAL/64	XTAL/128	XTAL/256
SubOSC	32.768kHz	8.192kHz	4.096kHz	2.048kHz	1.024kHz	512Hz	256Hz	128Hz

11. 16-Bit Timer

Overview

The Timer block consists of 10 channels of 16-bit general-purpose timers. They can support periodic timer, PWM pulse, one-shot timer, and capture mode.

- 16-bit up-counter
- Periodic timer mode
- One-shot timer mode
- PWM pulse mode
- Capture mode
- 10-bit prescaler
- Multi-channel synchronization function

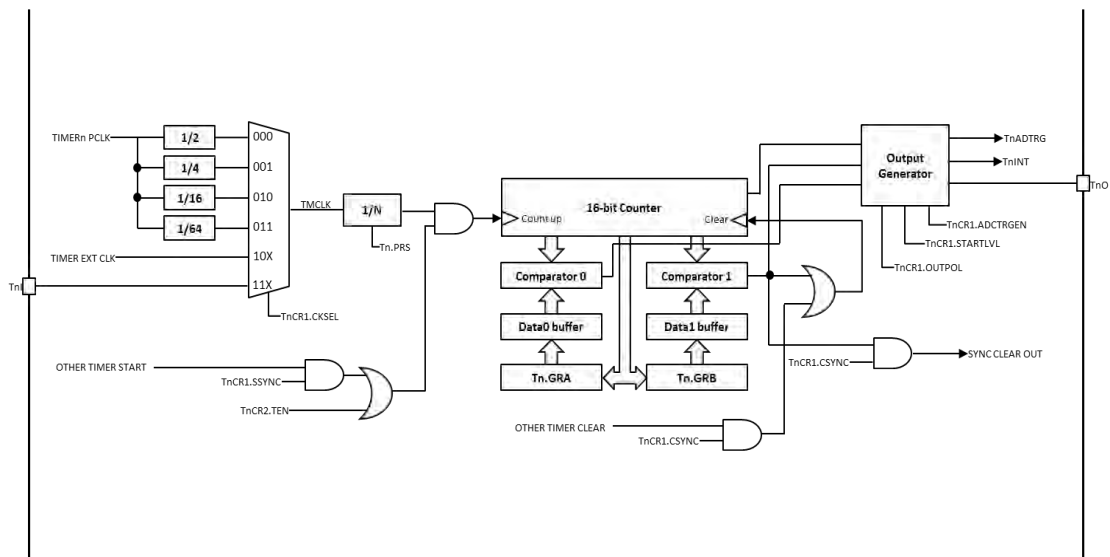

Figure 11.1. Block Diagram

Pin Description

Table 11.1. External Pin

PIN NAME	TYPE	DESCRIPTION
TnC	I	External clock / capture input
TnO	O	Timer output

Registers

The base address of the TIMER is 0x4000_3000 and the register map is described in Table.11.2 and 11.3.

Table 11.2. Base Address of Each Channel

CHANNEL	Address
T0	0x4000_3000
T1	0x4000_3020
T2	0x4000_3040
T3	0x4000_3060
T4	0x4000_3080
T5	0x4000_30A0
T6	0x4000_30C0
T7	0x4000_30E0
T8	0x4000_3100
T9	0x4000_3120

Table 11.3. Timer Register Map

Name	Offset	R/W	Description	Reset
Tn.CR1	0x-000	R/W	Timer control register 1	0x00000000
Tn.CR2	0x-004	R/W	Timer control register 2	0x00000000
Tn.PRS	0x-008	R/W	Timer prescaler register	0x00000000
Tn.GRA	0x-00C	R/W	Timer general data register A	0x00000000
Tn.GRB	0x-010	R/W	Timer general data register B	0x00000000
Tn.CNT	0x-014	R/W	Timer counter register	0x00000000
Tn.SR	0x-018	R/W	Timer status register	0x00000000
TnI.ER	0x-01C	R/W	Timer interrupt enable register	0x00000000

Tn.CR1Timer n Control Register 1

The Timer Control Register 1 is a 16-bit register.

The timer module should be correctly configured before running. When the target purpose is defined, the timer can be configured in the TnCR1 register.

T0.CR1=0x4000_3000, T1.CR1=0x4000_3020
T2.CR1=0x4000_3040, T3.CR1=0x4000_3060
T4.CR1=0x4000_3080, T5.CR1=0x4000_30A0
T6.CR1=0x4000_30C0, T7.CR1=0x4000_30E0
T8.CR1=0x4000_3100, T9.CR1=0x4000_3120

15	14	13	12	11	10	9	8	7	6	5	4	3	2	1	0
SSYNC	CSYNC	UAO	OUTPOL				ADCTRGEN	STARTLVL	CKSEL			CLRMD		MODE	
0	0	0	0	0	0	0	0	0	000			00		00	
R/W	R/W	R/W	R/W				R/W		R/W			R/W		R/W	

15	SSYNC	Synchronize start counter with other synchronized timers
		0 Single counter mode
		1 Synchronized counter start mode
14	CSYNC	Synchronize clear counter with other synchronized timers
		0 Single counter mode
		1 Synchronized counter clear mode
13	UAO	Select GRA, GRB update mode
		0 Writing GRA or GRB takes effect after current period
		1 Writing GRA or GRB takes effect in current period
12	OUTPOL	Timer output polarity
		0 Normal output
		1 Negated output
8	ADCTRGEN	ADC Trigger enable control
		0 Disable adc trigger
		1 Enable adc trigger
7	STARTLVL	Timer output polarity control
		0 Default output level is HIGH
		1 Defulat output level is LOW
6	CKSEL[2:0]	Counter clock source select
4		000 PCLK/2
		001 PCLK/4
		010 PCLK/16
		011 PCLK/64
		10X EXT0 (MCCR3)
	11X TnC pin input	
3	CLRMD	Clear select when capture mode
2		00 Rising edge clear mode
		01 Falling edge clear mode
		10 Both edge clear mode
		11 None clear mode
1	MODE[1:0]	Timer operation mode control
0		00 Normal periodic operation mode
		01 PWM mode
		10 One shot mode
		11 Capture mode

Tn.CR2Timer n Control Register 2

The Timer Control Register 2 is an 8-bit register.

T0.CR2=0x4000_3004, T1.CR2=0x4000_3024
 T2.CR2=0x4000_3044, T3.CR2=0x4000_3064
 T4.CR2=0x4000_3084, T5.CR2=0x4000_30A4
 T6.CR2=0x4000_30C4, T7.CR2=0x4000_30E4
 T8.CR2=0x4000_3104, T9.CR2=0x4000_3124

7	6	5	4	3	2	1	0
						TCLR	TEN
0	0	0	0	0	0	0	0
R	R	R	R	R	R	R/W	R/W

1	TCLR	Timer register clear
0		No
1		Clear count register (This bit will be cleared after next timer clock)
0	TEN	Timer enable bit
0		Stop Timer Counting
1		Start Timer Counting

It is recommended to start the timer with the TCLR bit set to '1'.

Tn.PRS Timer n Prescaler Register

The Timer Prescaler Register is a 16-bit register to prescale the counter input clock.

T0.PRS=0x4000_3008, T1.PRS=0x4000_3028
 T2.PRS =0x4000_3048, T3.PRS=0x4000_3068
 T4.PRS=0x4000_3088, T5.PRS=0x4000_30A8
 T6.PRS =0x4000_30C8, T7.PRS=0x4000_30E8
 T8.PRS=0x4000_3108, T9.PRS=0x4000_3128

15	14	13	12	11	10	9	8	7	6	5	4	3	2	1	0
PRS															
0	0	0	0	0	0	000									
R/W															

9	PRS	Pre-scale value of count clock
0		$TCLK = PCLK / (PRS + 1)$

Tn.GRA Timer n General Register A

The Timer General Register A is a 16-bit register. The GRA register is the duty register. This register controls the TxIO pin.

T0.GRA=0x4000_300C, T1.GRA=0x4000_302C
 T2.GRA =0x4000_304C, T3.GRA=0x4000_306C
 T4.GRA=0x4000_308C, T5.GRA=0x4000_30AC
 T6.GRA =0x4000_30CC, T7.GRA=0x4000_30EC
 T8.GRA=0x4000_310C, T9.GRA=0x4000_312C

15	14	13	12	11	10	9	8	7	6	5	4	3	2	1	0
GRA															
0x0000															
R/W															

15	GRA	Timer n General Register A (Duty/Interrupt Register)
0		Periodic mode / PWM / One-shot mode - Duty count value - When the counter value is matched with this value, GRA Match interrupt is requested
		Capture mode - Falling edge of TnC port will capture the count value when rising edge clear mode - Rising edge of TnC port will capture the count value when falling edge clear mode

Tn.GRB Timer n General Register B

Timer General Register B is a 16-bit register. The GRB register is the period match counter. It does not toggle the TxIO pins and is required in most modes as the period.

T0.GRB=0x4000_3010, T1.GRB=0x4000_3030
 T2.GRB=0x4000_3050, T3.GRB=0x4000_3070
 T4.GRB=0x4000_3090, T5.GRB=0x4000_30B0
 T6.GRB=0x4000_30D0, T7.GRB=0x4000_30F0
 T8.GRB=0x4000_3110, T9.GRB=0x4000_3130

15	14	13	12	11	10	9	8	7	6	5	4	3	2	1	0
GRB															
0x0000															
R/W															

15	GRB	Timer n General Register A (Period/Interrupt register)
0		Periodic mode / PWM / One-shot mode - In periodic mode or PWM mode, this register is used as Period value. The counter will count up to (GRB-1) value. - When the counter value is matched with this value, GRB Match interrupt is requested only in PWM and one-shot modes.
		Capture mode - Rising edge of TnC port will capture the count value when rising edge clear mode - Falling edge of TnC port will capture the count value when falling edge clear mode

Tn.CNT Timer n Counter Register

The Timer Counter Register is a 16-bit register.

T0.CNT=0x4000_3014, T1.CNT=0x4000_3034
 T2.CNT=0x4000_3054, T3.CNT=0x4000_3074
 T4.CNT=0x4000_3094, T5.CNT=0x4000_30B4
 T6.CNT=0x4000_30D4, T7.CNT=0x4000_30F4
 T8.CNT=0x4000_3114, T9.CNT=0x4000_3134

15	14	13	12	11	10	9	8	7	6	5	4	3	2	1	0
CNT															
0x0000															
R/W															

15	CNT	Timer count value
0		

Tn.SR Timer n Status Register

The Timer Status Register is an 8-bit register. This register indicates the current status of the timer module.

T0.SR=0x4000_3018, T1.SR=0x4000_3038
 T2.SR=0x4000_3058, T3.SR=0x4000_3078
 T4.SR=0x4000_3098, T5.SR=0x4000_30D8
 T6.SR=0x4000_30F8, T7.SR=0x4000_30F8
 T8.SR=0x4000_3118, T9.SR=0x4000_3138

7	6	5	4	3	2	1	0
					MFA	MFB	OVF
0	0	0	0	0	0	0	0
		R/W	R/W		R/W	R/W	R/W

2	MFA	GRA Match flag (Duty Match)
		0 No direction change
		1 Match flag with GRA
1	MFB	GRB Match flag (Period Match)
		0 No direction change
		1 Match flag with GRB
0	OVF	Counter overflow flag (Only occurs when counter rolls over at 0xFFFF)
		0 No direction change
		1 Counter overflow flag

Tn.IER Timer n Interrupt Enable Register

The Timer Interrupt Enable Register is an 8-bit register. Each status flag of the timer block can issue the interrupt. To enable the interrupt, write “1” in the corresponding bit in the TnIER register.

T0.IER=0x4000_301C, T1.IER=0x4000_303C
 T2.IER=0x4000_305C, T3.IER=0x4000_307C
 T4.IER=0x4000_309C, T5.IER=0x4000_30BC
 T6.IER=0x4000_30DC, T7.IER=0x4000_30FC
 T8.IER=0x4000_311C, T9.IER=0x4000_313C

7	6	5	4	3	2	1	0
					MAIE	MBIE	OVIE
0	0	0	0	0	0	0	0
	R/W	R/W	R/W		W	R/W	W

2	MAIE	GRA Match interrupt enable
		0 Not effect
		1 Enable match register A interrupt
1	MBIE	GRB Match interrupt enable
		0 Not effect
		1 Enable match register B interrupt
0	OVIE	Counter overflow interrupt enable
		0 Not effect
		1 Enable counter overflow interrupt

Functional Description

Basic Operation of Timer

In Figure 11.2, TMCLK is a reference clock for operation of the timer. This clock is divided by the prescaler setting and the counting clock will work. The following images show the starting point of the counter and the ending of the period point of the counter in normal periodic mode.

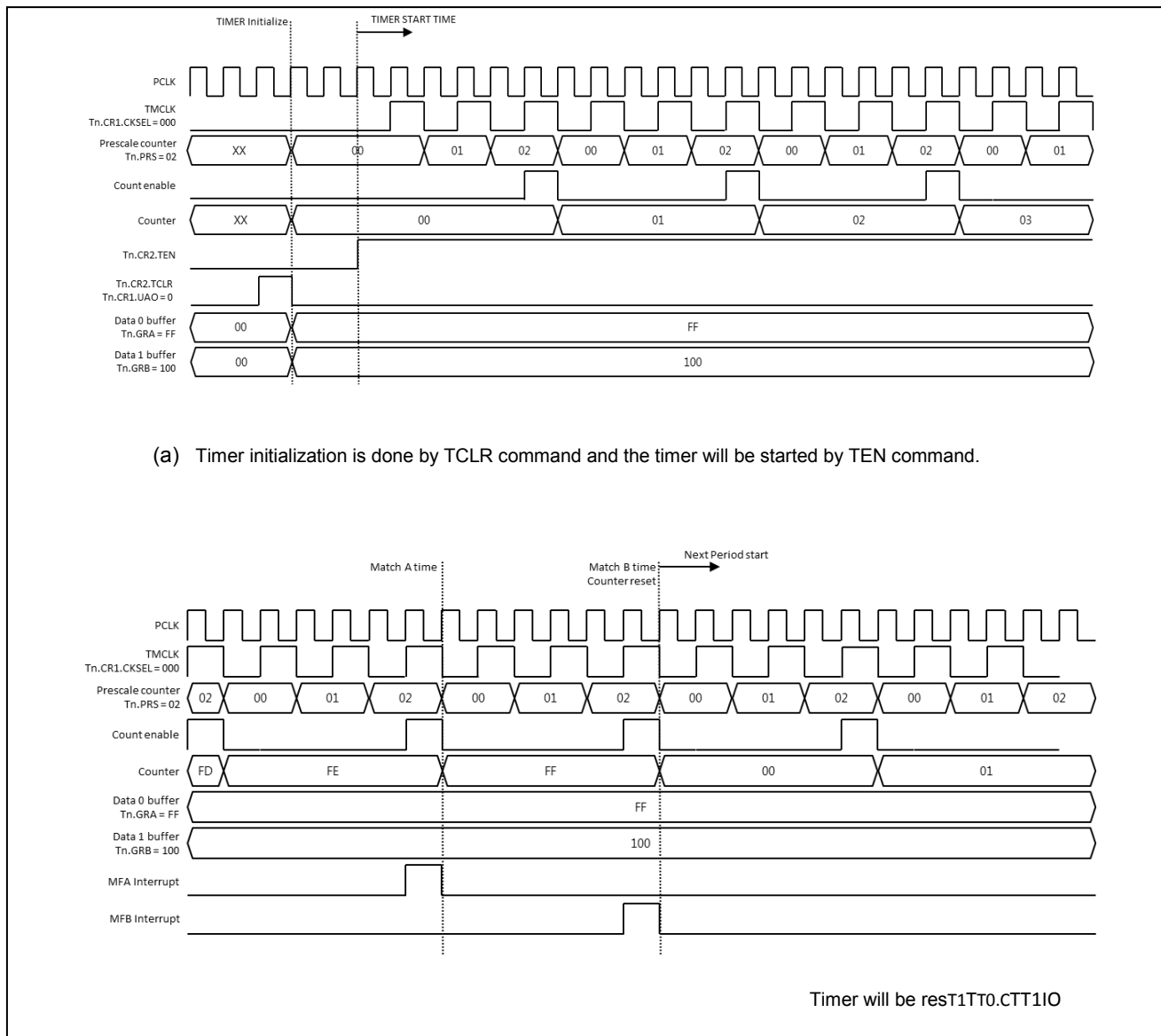

Figure 11.2. Basic Start and Match Operation

The period of timer count can be calculated as shown in the following equation:

The period = TMCLK Period * Tn.GRB value
Match A interrupt time = TMCLK Period * Tn.GRA value

If the Tn.CR1.UAO bit is "0", the Tn.CR2.TCLR command will initialize all the registers in the timer block and load the GRA and GRB value into the Data0 and Data1 buffers. When you change the timer setting and restart the timer with the new setting, write the CR2.TCLR command before the CR2.TEN command.

The update timing of the Data0 and Data1 buffers in dynamic operation is different in each operating mode and depends on the Tn.CR1.UAO bit.

Normal Periodic Mode

Figure 11.3 shows the timing diagram in normal periodic mode. The Tn.GRB value decides the timer period. An additional comparison point is provided with the Tn.GRA register value.

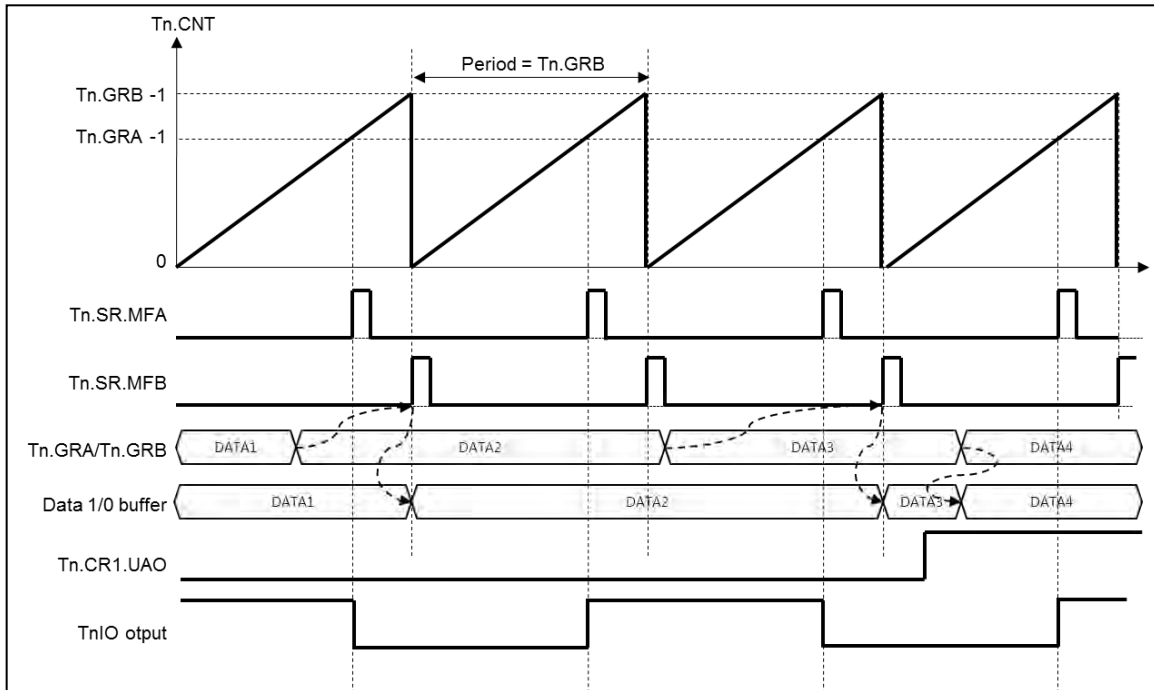

Figure 11.3. Normal Periodic Mode Operation

The period of the timer count can be calculated as shown in the following equation:

The period = TMCLK Period * Tn.GRB value
Match A interrupt time = TMCLK Period * Tn.GRA value

If Tn.GRB = 0, the timer cannot be started even if TnCR2.TEN is "1", because the period is "0".

The value in Tn.GRA and Tn.GRB is loaded into the internal compare data buffers 0 and 1 when the loading condition occurs. In this periodic mode with TnCR1.UAO = 0, the Tn.CR2.TCLR write operation and the GRB match event will load the compare data buffers.

When TnCR1.UAO is 1, the internal compare data buffer is updated when the Tn.GRA or Tn.GRB data is updated.

The TnIO output signal is toggled at the time of every Match A condition. If the value of TnGRA is 0, the TnIO output does not change its previous level. If TnGRA is the same as TnGRB, the TnIO output toggles at the same time as the counter start time. The initial level of the TnIO signal is decided by the TnCR1.STARTLVL value.

One Shot Mode

Figure 11.4 shows the timing diagram in One Shot mode. The Tn.GRB value decides the one shot period. An additional comparison point is provided with the Tn.GRA register value.

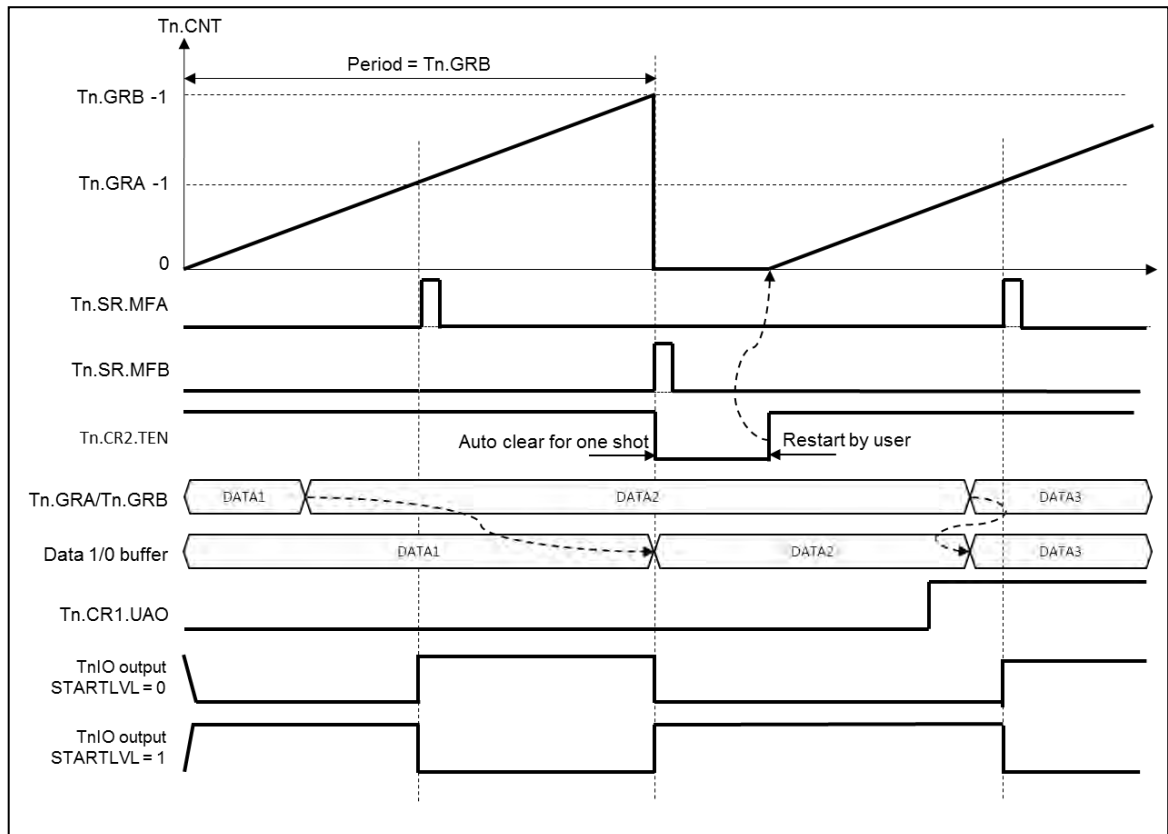

Figure 11.4. One Shot Mode Operation

The period of one shot count can be calculated as shown in the following equation:

The period = TMCLK Period * Tn.GRB value
Match A interrupt time = TMCLK Period * Tn.GRA value

If Tn.GRB = 0, the timer cannot be started even if TnCR2.TEN is "1" because the period is "0".

The value in Tn.GRA and Tn.GRB is loaded into the internal compare data buffers 0 and 1 when the loading condition occurs. In this periodic mode with TnCR1.UAO = 0, the Tn.CR2.TCLR write operation and the GRB match event will load the compare data buffers.

When TnCR1.UAO is 1, the internal compare data buffer is updated when the Tn.GRA or Tn.GRB data is updated.

The TnIO output signal format is the same as in PWM mode. The Tn.GRB value defines the output pulse period and the Tn.GRA value defines the pulse width of one shot pulse.

PWM Timer Output

Figure 11.5 shows the timing diagram in PWM output mode. The Tn.GRB value decides the PWM pulse period. An additional comparison point is provided with the Tn.GRA register value which defines the pulse width of PWM output.

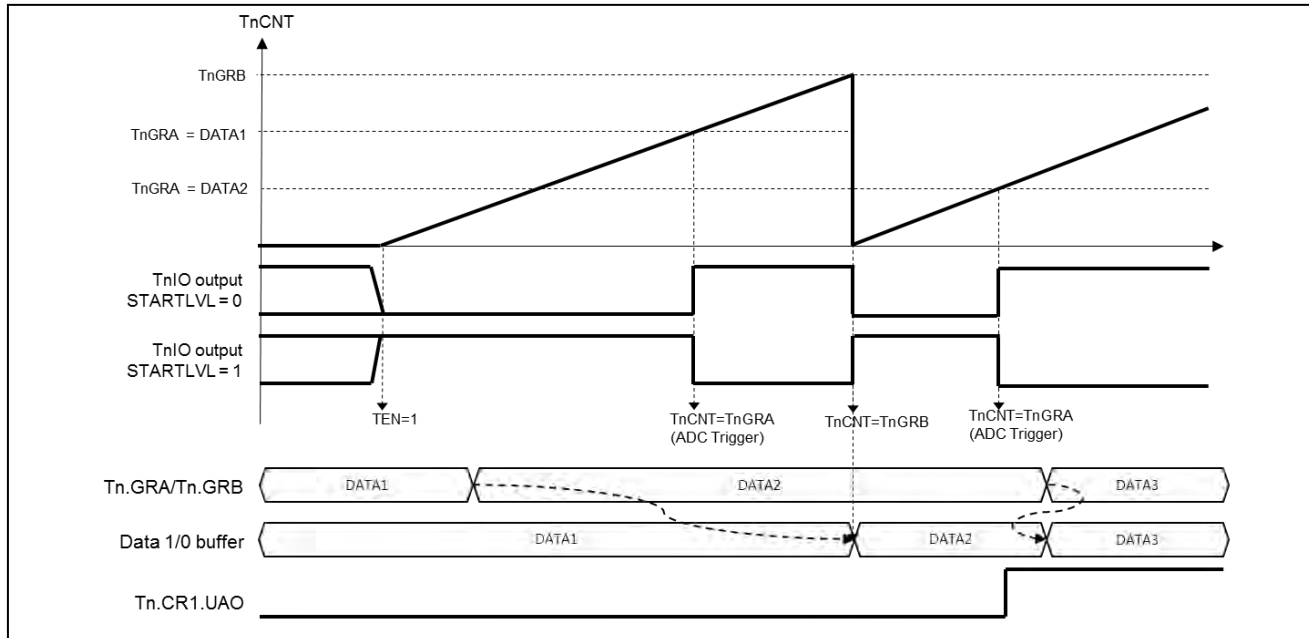

Figure 11.5. PWM Output Operation

The period of PWM pulse can be calculated as shown in the following equation:

The period = TMCLK Period * Tn.GRB value
Match A interrupt time = TMCLK Period * Tn.GRA value

If Tn.GRB = 0, the timer cannot be started even if TnCR2.TEN is "1" because the period is "0".

The value in Tn.GRA and Tn.GRB is loaded into the internal compare data buffer 0 and 1 when the loading condition occurs. In this periodic mode with TnCR1.UAO = 0, the Tn.CR2.TCLR write operation and the GRB match event will load the compare data buffers.

When TnCR1.UAO is 1, the internal compare data buffer is updated when the Tn.GRA or Tn.GRB data is updated.

The TnIO output signal generates a PWM pulse. The Tn.GRB value defines the output pulse period and the Tn.GRA value defines the pulse width of one shot pulse. The active level of the PWM pulse can be controlled by the Tn.CR1.STARTLVL bit value.

ADC Trigger generation is available at Match A interrupt time.

PWM Synchronization Function

2 PWM outputs are usually used as synchronous PWM signal control. This function is provided with a synchronous start function.

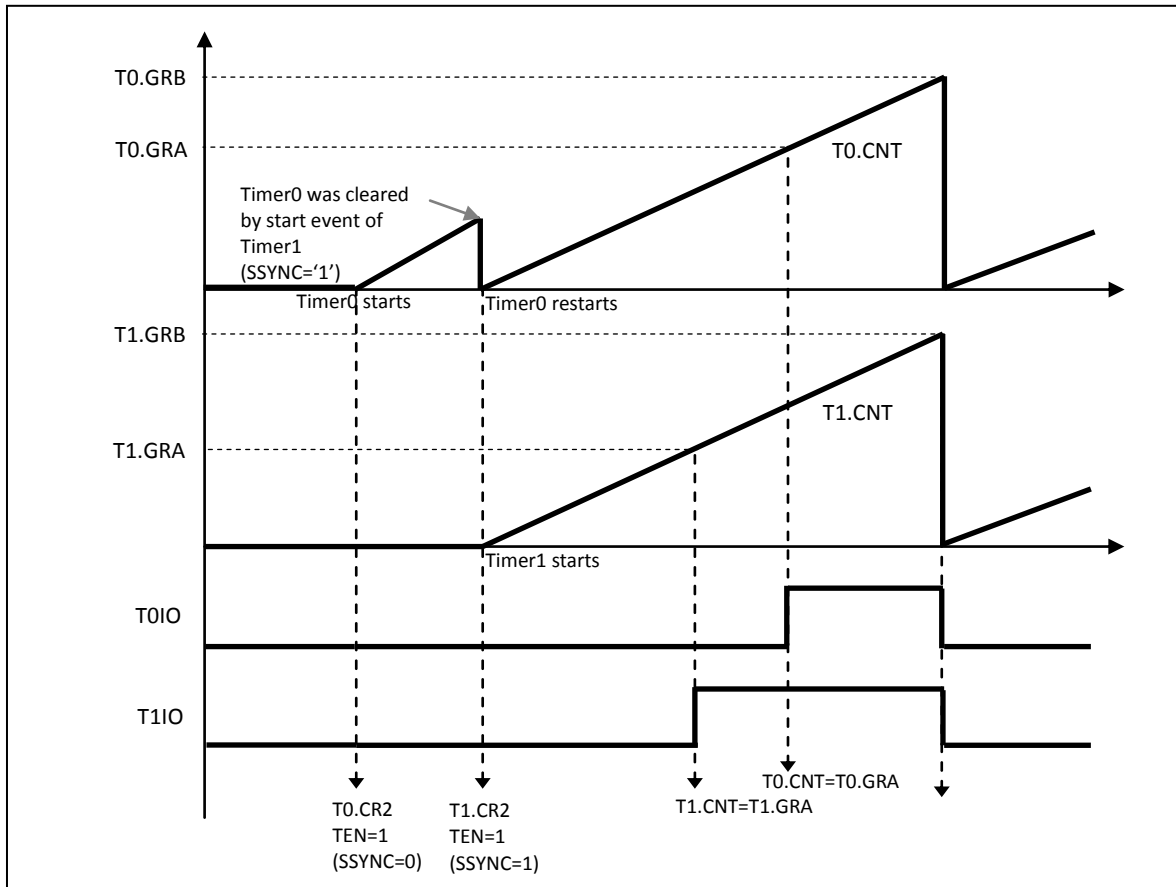

Figure 11.6 shows the synchronous PWM generation function.

Figure 11.6. An Example of the Timer Synchronization Function (SSYNC='0')

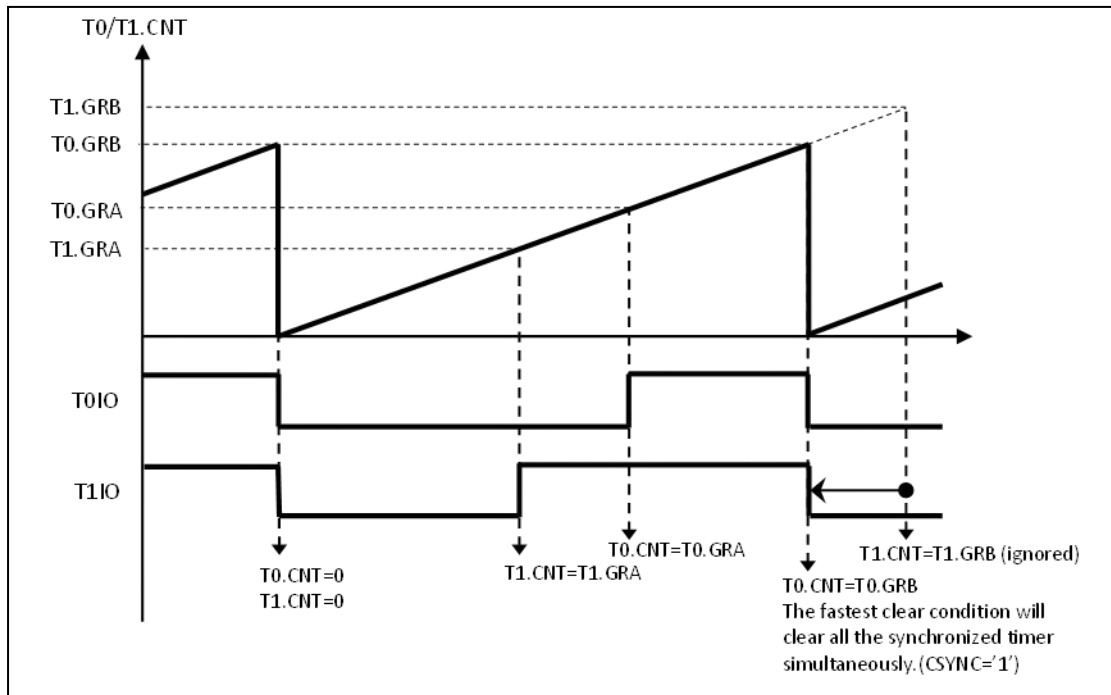

Figure 11.7. An Example of the Timer Synchronization Function (CSYNC='1')

The TnCR1.SSYNC bit controls start synchronization with other timer blocks. The TnCR1.CSYCN bit controls clear sync with other timer blocks. The SSYNC and CSYCN bits are only effective when used with two or more timers.

For example, timer0 and timer1 set the SSYNC and CCSYCN bits in each CR1 register; both timers are started when one of them is enabled. Both timers are cleared with a short period match value. However, others are not affected by these 2 timers, and they can be operated independently because their SYNC control bit is 0.

Capture Mode

Figure 11.8 shows the timing diagram in Capture mode operation. The TnIO input signal is used for the capture pulse. Both rising and falling edges can capture the counter value in each capture condition.

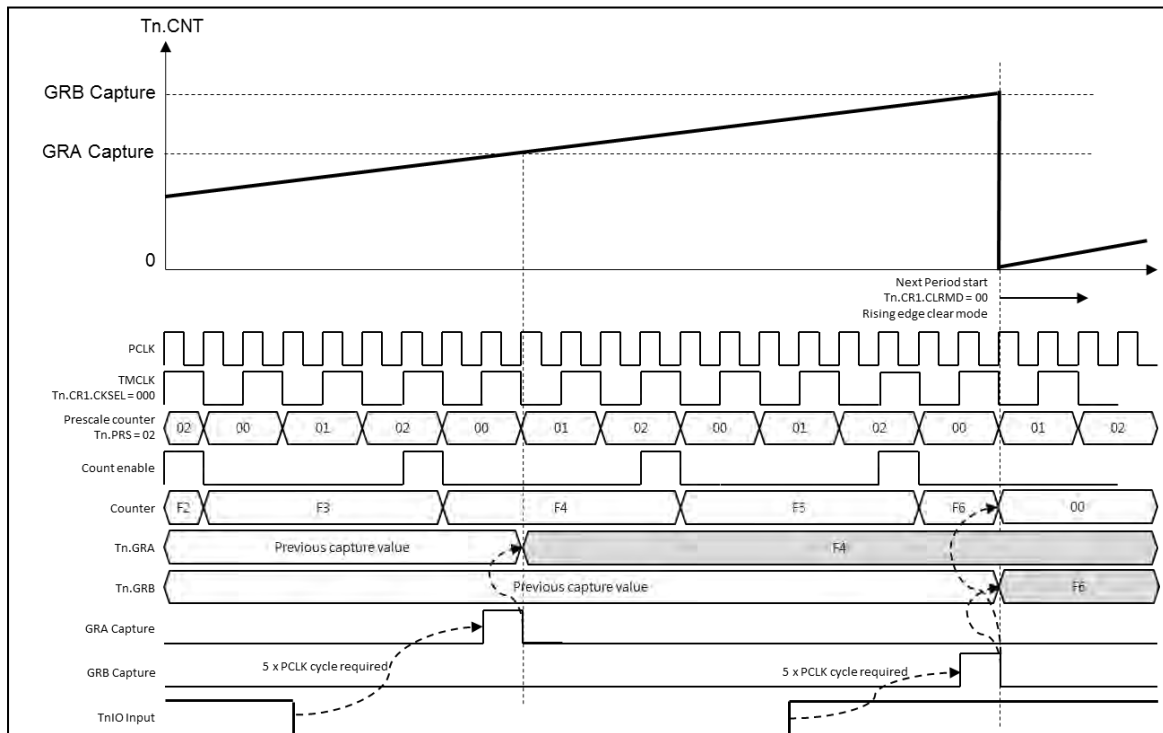

Figure 11.8. Capture Mode Operation

A 5 PCLK clock cycle is required internally. Therefore, the actual capture point is after 5 PCLK clock cycles from the rising or falling edge of the TnIO input signal.

The internal counter can be cleared in various modes. The TnCR1.CLRMD field controls the counter clear mode. Rising Edge clear mode, Falling Edge clear mode, Both Edges clear mode, and None clear mode are supported.

Figure 11.8 displays the rising edge clear mode.

ADC Trigger Function

The timer module can generate ADC start trigger signals. One timer can be one trigger source of the ADC block. Trigger source control is performed by the ADC control register.

Figure 11.9 shows the ADC trigger function.

The conversion rate must be shorter than the timer period. If this is not true, an overrun situation can occur. ADC acknowledge is not required because the trigger signal will be cleared automatically after 3 PCLK clock pulses.

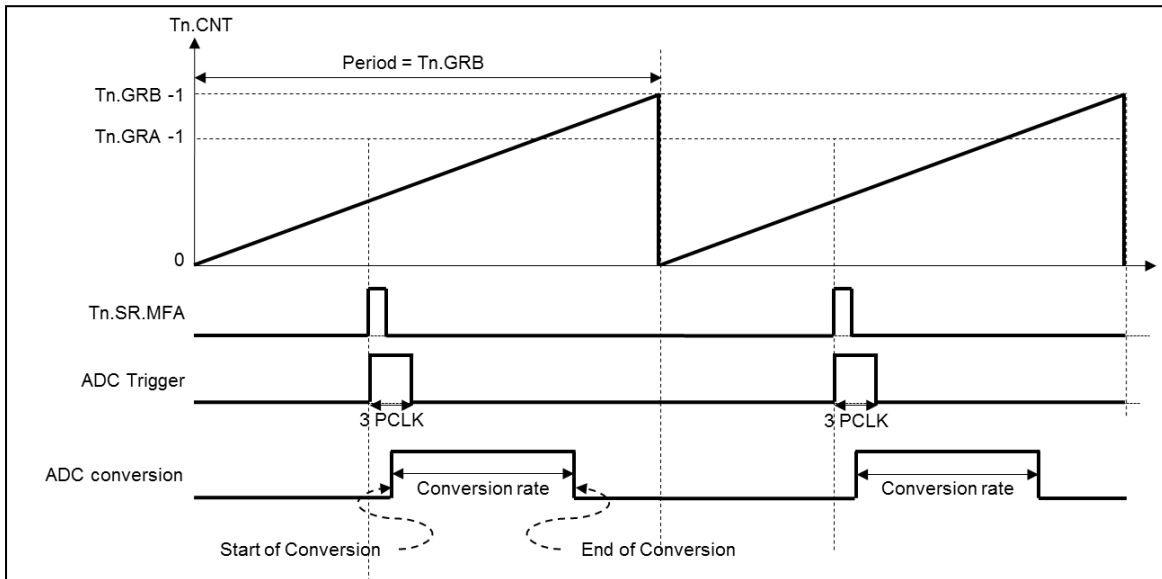

Figure 11.9. ADC Trigger Function Timing Diagram

12. 32-Bit Free Run Timer

Overview

The FRT block is a 32-bit Free Run Timer. It can be used in power down mode.

- 32-bit up-counter with SUB OSC
- Matched interrupt

Registers

The base address of FRT is 0x4000_30E0 and the register map is described in Tables 12.1 and 12.2.

Table 12.1. Base Address of Each Channel

Channel	Address
FRT	0x4000_0600

Table 12.2. Timer Register Map

Name	Offset	R/W	Description	Reset
FRT.MR	0x0000	R/W	FRT mode register	0x00000000
FRT.CR	0x0004	R/W	FRT control register	0x00000000
FRT.PER	0x0008	R/W	FRT period register	0x00000000
FRT.CNT	0x000C	RO	FRT counter register	0x00000000
FRT.SR	0x0010	R/W	FRT status register	0x00000000

FRT.MR FRT Mode Register

FRT is a 32-bit up counter. It can be used in power down mode. The SUB OSC clock is directly connected to FRT. The clock is uncontrollable in the SCU block. The FRT Mode Register is an 8-bit register.

FRTMR=0x4000_0600

7	6	5	4	3	2	1	0
			CLKSEL		MCD	OVIE	MIE
0	0	0	00		0	0	0
			RW		RW	RW	RW

3	CLKSEL	FRT counter clock source control
2		0 Internal Oscillator clock divided by 16
		1 External Oscillator clock divided by 16
		2 Sub Oscillator clock
		3 Reserved
1	MCD	Counter Match Clear Disable bit
		0 Counter Match Clear function is enabled. Whenever the counter matches FRT.PER, the counter will be set zero and waiting for MF to be cleared.
		1 Counter Match Clear function is disabled. The counter will keep countering without set zero
1	OVIE	Overflow Interrupt Enable bit
		0 Not effect
		1 Interrupt enabled
0	MIE	Match Interrupt Enable bit
		0 Not effect
		1 Interrupt enabled

FRT.CR FRT Control Register

The FRT Control register is an 8-bit register.

FRTCR=0x4000_3E04

7	6	5	4	3	2	1	0
				CNTREQ	FCLR	FHOLD	FEN
0	0	0	0	0	0	0	0
				RW	WO	R/W	R/W

3	CNTREQ	FRT Counter read request bit
		0 No
		1 Request to read FCNT (cleared when CNTACK(FSR[1]) is high)
2	FCLR	FRT Counter register clear bit
		0 No
		1 Clear the counter
1	FHOLD	FRT Counter register hold bit
		0 No
		1 Hold the counter
0	FEN	FRT enable bit
		0 FRT Disabled
		1 FRT Enabled

FRT.PER FRT Period Match Register

The FRT Period Match register is a 32-bit register.

FRTPER=0x4000_3E08

31	30	29	28	27	26	25	24	23	22	21	20	19	18	17	16	15	14	13	12	11	10	9	8	7	6	5	4	3	2	1	0
DATA																															
0x0000_0000																															
R/W																															

32	DATA	FRT match data
0		

FRT.CNT FRT Counter Register

The FRT Counter Register is a 32-bit register.

FRTCNT=0x4000_3E0C

31	30	29	28	27	26	25	24	23	22	21	20	19	18	17	16	15	14	13	12	11	10	9	8	7	6	5	4	3	2	1	0
CNT																															
0x0000_0000																															
RO																															

32	CNT	FRT Counter
0		

FRT.SRFRT Status Register

FRT Status Register is an 8-bit register. FRTSR=0x4000_0610

7	6	5	4	3	2	1	0
					RACK	OVIF	MIF
0	0	0	0	0	0	0	0
					WC1	WC1	WC1

2	RACK	Read Counter Acknowledge bit
		0 Not ready to read CNT value
		1 Ready to read CNT value
1	OVIF	Overflow interrupt flag bit
		0 Overflow interrupt did not occur
		1 Overflow interrupt occurred
0	MIF	Match interrupt flag bit
		0 Match interrupt did not occur.
		1 Match Interrupt occurred
		In Counter Match Clear mode, this bit should be cleared for restarting the counter.

Functional Description

FRT has two types of interrupt:

- Match interrupt
- Overflow interrupt

Match Interrupt Operation

The match interrupt timing diagram is shown in

Figure 12.1. FRT.MR.MIE should be set as '1' for using match-interrupt.

The FRT clock starts the FRT counter after FRT.CR.EN is '1'. Interrupt and wakeup signals occur when the counter is matched with the value of FRT.PER. The 'interrupt' signal might be delayed in a maximum of 2 system clocks and 'wakeup' signal might be delayed in a maximum of (1 clk + 2 frt_clk).

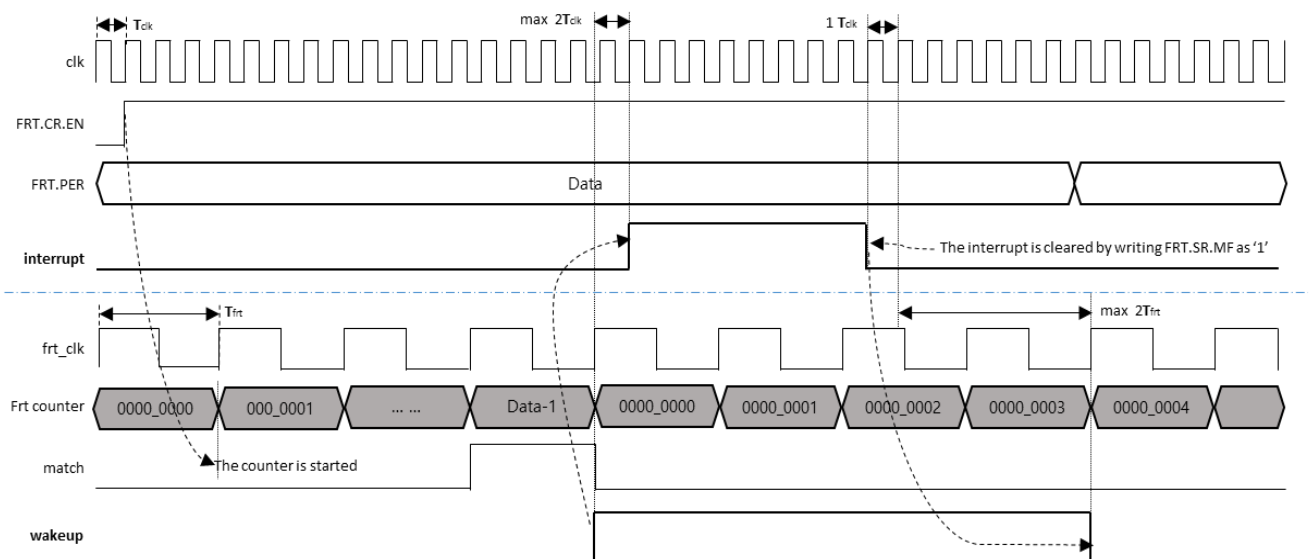

Figure 12.1. Match Interrupt Operation Timing Diagram

Overflow Interrupt Operation

The overflow interrupt timing diagram is shown in

Figure 12.2. The overflow-interrupt operation is similar to the match-interrupt operation. The overflow-interrupt is started to set when the FRT counter matches 0xFFFFFFFF.

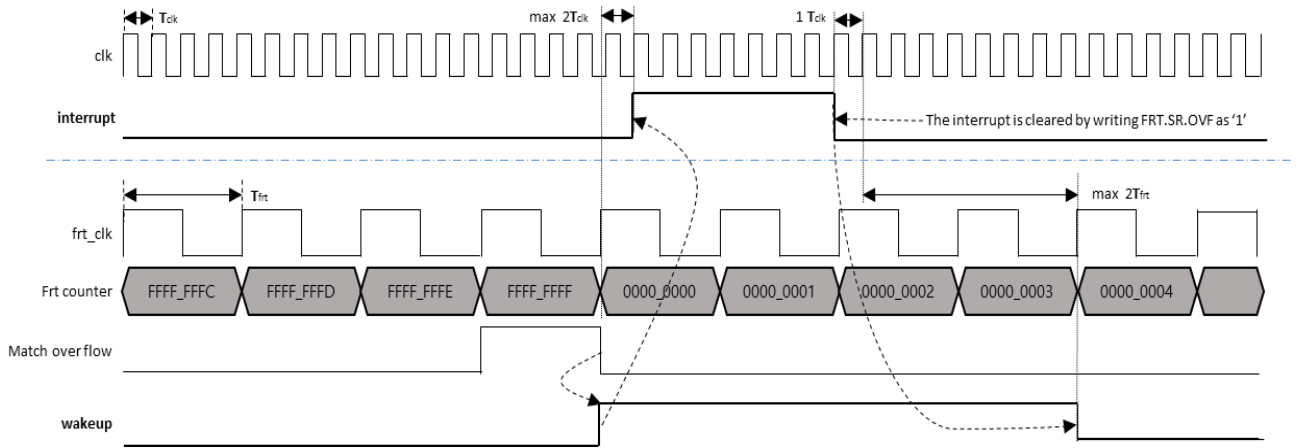

Figure 12.2. Overflow Interrupt Operation Timing Diagram

13. UART

Overview

4-Channel Universal Asynchronous Receiver/Transmitter (UART) modules are provided. There is dedicated DMA support to data transfer between the memory buffer and the transmit or receive buffer of the UART block.

The UART operation status, including error status, can be read from the status register. The prescaler, which generates the correct baud rate, exists for each UART channel. The prescaler can divide the UART clock source, PCLK/2, from 1 to 65535. The baud rate is generated by the clock which is internally divided by 16 of the prescaled clock and 8-bit precision clock tuning function.

The programmable interrupt generation function helps control communication via the UART channel.

Features

- Compatible with 16450
- Supports DMA transfer
- Standard asynchronous control bit (start, stop, and parity) configurable
- Programmable 16-bit fractional baud generator
- Programmable serial communication
- 5-, 6-, 7- or 8- bit data transfer
- Even, odd, or no-parity bit insertion and detection
- 1-, 1.5- or 2-stop bit-insertion and detection
- 16-bit baud rate generation with 8-bit fraction control
- Hardware inter-frame delay function
- Stop bit error detection
- Detail status register

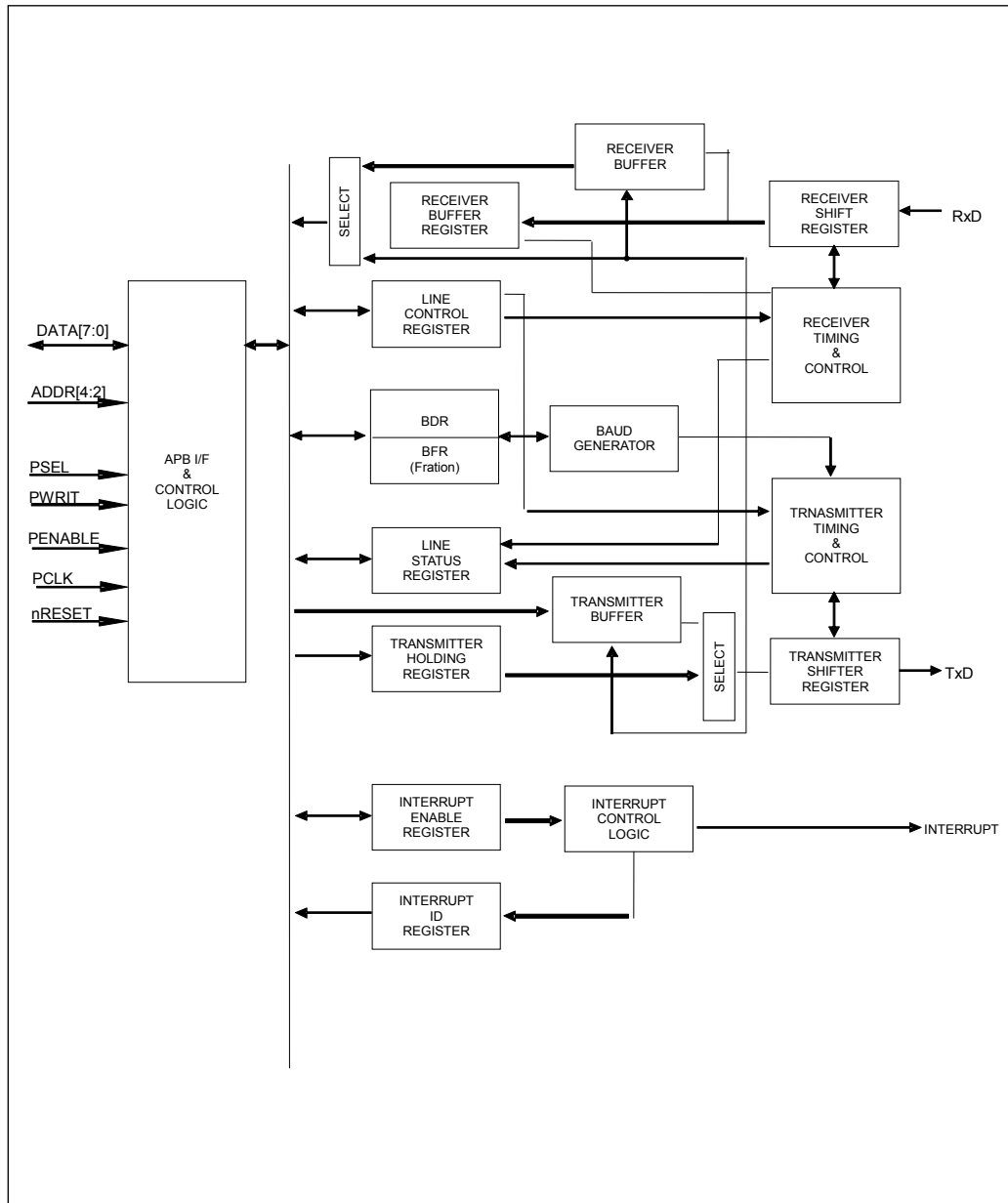

Figure 13.1. Block Diagram

Pin Description

Table 13.1. External Signal

PIN NAME	TYPE	DESCRIPTION
TXD0	O	UART Channel 0 transmit output
RXD0	I	UART Channel 0 receive input
TXD1	O	UART Channel 1 transmit output
RXD1	I	UART Channel 1 receive input
TXD2	O	UART Channel 2 transmit output
RXD2	I	UART Channel 2 receive input
TXD3	O	UART Channel 3 transmit output
RXD3	I	UART Channel 3 receive input

Registers

The base address of UART is 0x4000_8000 and the register map is described in Tables 13.2 and 13.3.

Table 13.2. Base Address of Each Port

UART Channel	Address
UART0	0x4000_8000
UART1	0x4000_8100
UART2	0x4000_8200
UART3	0x4000_8300

Table 13.3. UART Register Map

Name	Offset	R/W	Description	Reset
Un.RBR	0x00	R	Receive data buffer register	0x00
Un.THR	0x00	W	Transmit data hold register	0x00
Un.IER	0x04	R/W	Interrupt enable register	0x00
Un.IIR	0x08	R	Interrupt ID register	0x01
Un.LCR	0x0C	R/W	Line control register	0x00
Un.DCR	0x10	R/W	Data Control Register	
Un.LSR	0x14	R	Line status register	0x00
Un.SCR	0x1C	R/W	Scratch pad register	0x00
Un.BDR	0x20	R/W	Baud rate Divisor Latch Register	
Un.BFR	0x24	R/W	Baud rate Fractional Counter Value	0x00
Un.IDTR	0x30	R/W	Inter-frame Delay Time Register	0x00

Un.RBR Receive Buffer Register

The UART Receive Buffer Register is an 8-bit read-only register.

U0.RBR=0x4000_8000, U1.RBR=0x4000_8100
 U2.RBR=0x4000_8200, U3.RBR=0x4000_8300

7	6	5	4	3	2	1	0
RBR[7:0]							
-							
RO							

7	RBR	Receive Buffer Register
0		

Un.THR Transmit Data Hold Register

The UART Transmit Data Hold Register is an 8-bit write-only register.

U0.THR=0x4000_8000, U1.THR=0x4000_8100
 U2.THR=0x4000_8200, U3.THR=0x4000_8300

7	6	5	4	3	2	1	0
THR							
-							
WO							

7	THR	Transmit Data Hold Register
0		

Un.IER UART Interrupt Enable Register

The UART Interrupt Enable Register is an 8-bit register.

U0.IER=0x4000_8004, U1.IER=0x4000_8104
 U2.IER=0x4000_8204, U3.IER=0x4000_8304

7	6	5	4	3	2	1	0
-	-	DTXIEN	DRXIEN	TXEIE	RLSIE	THREIE	DRIE
0	0	0	0	0	0	0	0
		RW	RW	RW	RW	RW	RW

5	DTXIEN	DMA transmit done interrupt enable
	0	Receive line status interrupt is disabled
	1	Receive line status interrupt is enabled
4	DRXIEN	DMA receive done interrupt enable
	0	DMA receive done interrupt is disabled
	1	DMA receive done interrupt is enabled
3	TXEIE	End-of-transmit interrupt enable
	0	End-of-transmit interrupt is disabled
	1	End-of-transmit interrupt is enabled
2	RLSIE	Receiver line status interrupt enable
	0	Receive line status interrupt is disabled
	1	Receive line status interrupt is enabled
1	THREIE	Transmit holding register empty interrupt enable
	0	Transmit holding register empty interrupt is disabled
	1	Transmit holding register empty interrupt is enabled
0	DRIE	Data receive interrupt enable
	0	Data receive interrupt is disabled
	1	Data receive interrupt is enabled

Un.IIR UART Interrupt ID Register

The UART Interrupt ID Register is an 8-bit register. Reading this register will clear the interrupts.

U0.IIR=0x4000_8008, U1.IIR=0x4000_8108
U2.IIR=0x4000_8208, U3.IIR=0x4000_8308

7	6	5	4	3	2	1	0
			TXE		IID		IPEN
0	0	0	0		000		0
			R		R		R

4	TXE	Interrupt source ID See interrupt source ID table
3	IID	Interrupt source ID See interrupt source ID table
1		
0	IPEN	Interrupt pending bit
	0	Interrupt is pending
	1	No interrupt is pending.

The UART supports 3-priority interrupt generation and the Interrupt Source ID register shows one interrupt source which has the highest priority amongst pending interrupts. The priority is defined as follows:

- Receive line status interrupt
- Receive data ready interrupt/ character timeout interrupt
- Transmit hold register empty interrupt
- Tx/Rx DMA complete interrupt

Priority	TXE	DMA	IID		IPEN	Interrupt sources		
	Bit 4	Bit 3	Bit 2	Bit 1	Bit 0	Interrupt	Interrupt condition	Interrupt clear
-	0	0	0	0	1	None	-	-
1	0	0	1	1	0	Receiver Line Status	Overrun, Parity, Framing or Break Error	Read LSR register
2	0	0	1	0	0	Receiver Data Available	Receive data is available.	Read receive register or read IIR register
3	0	0	0	1	0	Transmitter Holding Register Empty	Transmit buffer empty	Write transmit hold register or read IIR register
4	1	X	X	X	X	Transmitter Register Empty	Transmit register empty	Write transmit hold register or read IIR register
5	0	1	1	0	0	Rx DMA done	Rx DMA completed.	Read IIR register
6	0	1	0	1	0	Tx DMA done	Tx DMA completed.	Read IIR register
7	1	X	X	X	X	Transmitter register Empty and DMA done	Transmitter register Empty and Tx DMA completed.	Read IIR register

Un.LCR UART Line Control Register

The UART Line Control Register is an 8-bit register.

U0.LCR=0x4000_800C, U1.LCR=0x4000_810C
U2.LCR=0x4000_820C, U3.LCR=0x4000_830C

7	6	5	4	3	2	1	0
	BREAK	STICKP	PARITY	PEN	STOPBIT	DLEN	
0	0	0	0	0	0	0	0
	R/W	R/W	R/W	R/W	R/W	R/W	R/W

6	BREAK	When this bit is set, TxD pin will be driven at low state in order to notice the alert to the receiver. 0 Normal transfer mode 1 Break transmit mode
5	STICKP	Force parity and it will be effective when PEN bit is set. 0 Parity stuck is disabled 1 Parity stuck is enabled and parity always the bit of PARITY.
4	PARITY	Parity mode selection bit and stuck parity select bit 0 Odd parity mode 1 Even parity mode
3	PEN	Parity bit transfer enable 0 The parity bit disabled 1 The parity bit enabled
2	STOPBIT	The number of stop bit followed by data bits. 0 1 stop bit 1 1.5 / 2 stop bit In case of 5 bit data case, 1.5 stop bit is added. In case of 6,7 or 8 bit data, 2 stop bit is added
1 0	DLEN	The data length in one transfer word. 00 5 bit data 01 6 bit data 10 7 bit data 11 8 bit data

The parity bit is generated according to bits 3,4,5 of the UnLCR register. Table 13.4 shows the variation of parity bit generation.

Table 13.4. Parity Bit Generation

STICKP	PARITY	PEN	Parity
X	X	0	No Parity
0	0	1	Odd Parity
0	1	1	Even Parity
1	0	1	Force parity as "1"
1	1	1	Force parity as "0"

Un.DCR UART Data Control Register

The UART Data Control Register is an 8-bit register.

U0DCR=0x4000_8010, U1DCR=0x4000_8110
 U2DCR=0x4000_8210, U3DCR=0x4000_8310

7	6	5	4	3	2	1	0
				RXINV	TXINV		
0	0	0	0	0	0	0	0
				R/W	R/W		

3	RXINV	Rx Data Inversion Selection
		0 Normal RxData Input
		1 Inverted RxData Input
2	TXINV	Tx Data Inversion Selection
		0 Normal TxData Output
		1 Inverted TxData Output

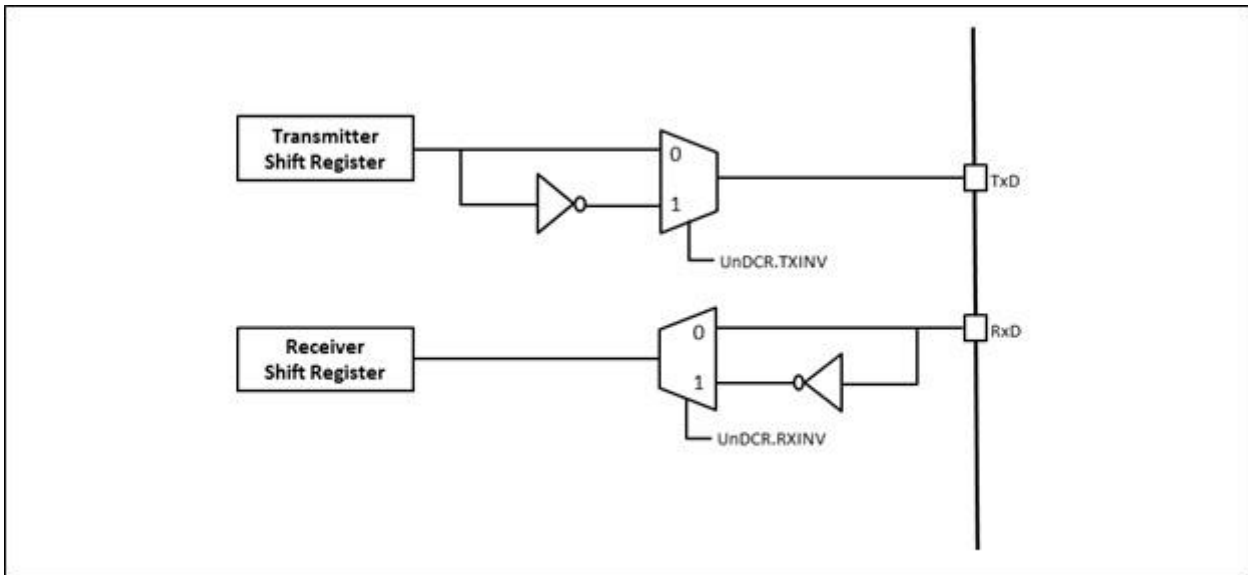

Figure 13.2. Data Inversion Diagram

Un.LSR UART Line Status Register

The UART Line Status Register is an 8-bit register.

U0LSR=0x4000_8014, U1LSR=0x4000_8114
U2LSR=0x4000_8214, U3LSR=0x4000_8314

7	6	5	4	3	2	1	0
-	TEMT	THRE	BI	FE	PE	OE	DR
0	1	1	0	0	0	0	0
	R	R	R	R	R	R	R
		6	TEMT	Transmit empty.			
				0	Transmit register has the data is now transferring		
				1	Transmit register is empty.		
		5	THRE	Transmit holding empty.			
				0	Transmit holding register is not empty.		
				1	Transmit holding register empty		
		4	BI	Break condition indication bit			
				0	Normal status		
				1	Break condition is detected		
		3	FE	Frame Error.			
				0	No framing error.		
				1	Framing error. The receive character did not have a valid stop bit		
		2	PE	Parity Error			
				0	No parity error		
				1	Parity error. The receive character does not have correct parity information.		
		1	OE	Overrun error			
				0	No overrun error		
				1	Overrun error. Additional data arrives while the RHR is full		
		0	DR	Data received			
				0	No data in receive holding register.		
				1	Data has been received and is saved in the receive holding register		

This register provides the status of data transfers between the transmitter and receiver. Users can get line status information from this register and can handle the next process. Bits 1,2,3,4 will arise the line status interrupt when the RLSIE bit in the UnIEN register is set. Other bits can generate its interrupt when the interrupt enable bit in the UnIEN register is set.

Un.BDR Baud rate Divisor Latch Register

The UART Baud rate Divisor Latch Register is a 16-bit register.

U0.BDR=0x4000_8020, U1.BDR=0x4000_8120
U2.BDR=0x4000_8220, U3.BDR=0x4000_8320

15	14	13	12	11	10	9	8	7	6	5	4	3	2	1	0
BDR															
0x0000															
R/W															
15	BDR														
0	Baud rate Divider latch value														

To establish communication with the UART channel, the baud rate should be set correctly. The programmable baud rate generation allows division from 1 to 65535. The 16 bit divider register (UnBDR) should be written for the expected baud rate.

The baud rate calculation formula is shown in the following equation:

$$BDR = \frac{UART_{PCLK}}{32 \times BaudRate}$$

For an 72 MHz UART_PCLK speed, the divider value and error rate is described in Table 13.5.

Table 13.5. Example of Baud Rate Calculation

UART_PCLK=72 MHz		
Baud rate	Divider	Error (%)
1200	1875	0.00%
2400	937	0.05%
4800	468	0.16%
9600	234	0.16%
19200	117	0.16%
38400	58	1.02%
57600	39	0.16%
115200	19	2.79%

Un.BFR Baud rate Fraction Counter Register

The Baud rate Fraction Counter Register is an 8-bit register.

U0.BFR=0x4000_8024, U1.BFR=0x4000_8124
 U2.BFR=0x4000_8224, U3.BFR=0x4000_8324

7	6	5	4	3	2	1	0
BFR							
0x00							
R/W							

7	BFR	Fractions counter value.
0		0 Fraction counter is disabled
		N Fraction counter enabled. Fraction compensation mode is operating. Fraction counter is incremented by FCNT.

Table 13.6 Example of Baud Rate Calculation

UART_PCLK=72 MHz			
Baud rate	Divider	FCNT	Error (%)
1200	1875	0	0.0%
2400	937	128	0.0%
4800	468	192	0.0%
9600	234	96	0.0%
19200	117	48	0.0%
38400	58	152	0.0%
57600	39	16	0.0%
115200	19	136	0.0%

$$FCNT = Float * 256$$

The 8-bit fractional counter will count up by the FCNT value every (baud rate)/16 period and when the fractional counter overflow occurs, the divisor value increments by 1. Therefore, this period is compensated. In the next period, the divisor value returns to the original set value.

For example, if 9600 bps,

$$\frac{PCLK / 2}{16 \times BaudRate} = \frac{7200000 / 2}{16 \times 9600} = 234.375 \quad \text{Divider} = 234 \quad \text{Float} = .375$$

$$FCNT = Float \times 256 = .375 \times 256 = 96$$

BDR = 234, BFR = 96

Un.IDTR Inter-frame Delay Time Register

The UART Inter-frame Time Register is an 8-bit register. A dummy delay can be inserted between two continuous transmits.

U0.IDTR=0x4000_8030, U1.IDTR=0x4000_8130

U2.IDTR=0x4000_8230, U3.IDTR=0x4000_8330

7	6	5	4	3	2	1	0
-					WAITVAL		
0	0	0	0	0	000		
RW							

2	WAITVAL	Wait time is decided by this value
0		

$$\text{Wait Time} = \frac{\text{WAITVAL}}{\text{BAUDRATE}}$$

Functional Description

The UART module is compatible with the 16450 UART. Additionally, dedicated DMA channels and fractional baud rate compensation logic are provided. The UART does not have an internal FIFO block. Therefore, data transfers are established interactively or with DMA support.

Two DMA channels are provided for each UART module – one channel for TX transfer and the other channel for RX transfer. Each channel has a 32-bit memory address register and a 16-bit transfer counter register. Prior to the DMA operation, the DMA memory address register and transfer count register should be configured. For the RX operation, the memory address is the destination memory address and for the TX operation, the memory address is the source memory address.

The transfer counter register stores the number of data transfers. When a single transfer is done, the counter is decremented by 1. When the counter reaches zero, the DMA done flag is delivered to the UART control block. If the interrupt is enabled, this flag generates the interrupt.

Receiver Sampling Timing

The UART operates per the following timing:

If the falling edge is on the receive line, the UART judges it as the start bit. From the start timing, the UART oversamples 16 times of 1-bit and detects the bit value at the 7th sample of 16 samples.

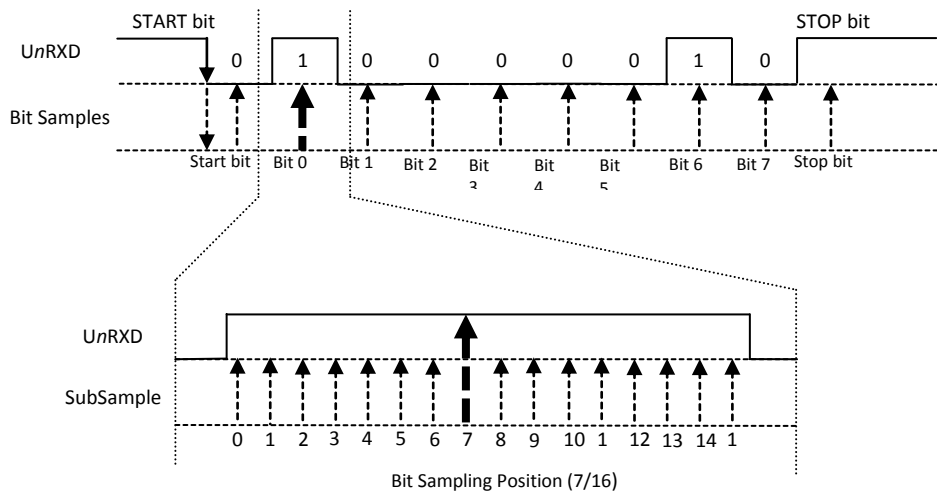

Figure 13.3 The Sampling Timing of UART Receiver

Note: Zilog recommends enabling debounce settings in the PCU block to reinforce the immunity of external glitch noise.

Transmitter

The transmitter's function is to transmit data. The start bit, data bits, optional parity bit, and stop bit are serially shifted with the least significant bit first. The number of data bits is selected in the DLAN[1:0] field in the Un.LCR register.

The parity bit is set according to the PARITY and PEN bit field in the Un.LCR register. If the parity type is even, then the parity bit depends on the one bit sum of all data bits. For odd parity, the parity bit is the inverted sum of all data bits.

The number of stop bits is selected in the STOPBIT field in the Un.LCR register.

An example of transmit data format is shown in Figure 13.4.

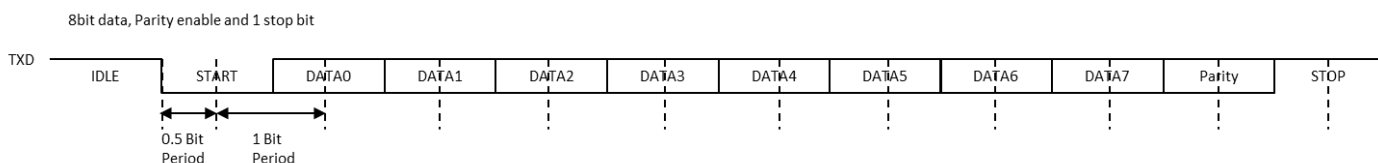

Figure 13.4. Transmit Data Format Example

Inter-frame Delay Transmission

The Inter-frame Delay function allows the transmitter to insert an idle state on the TXD line between two characters. The width of the idle state is defined in the WAITVAL field in the Un.IDTR register. When this field is set to 0, no time-delay is generated. Otherwise, the transmitter holds a high level on TXD after each transmitted character during the number of bit periods defined in the WATIVAL field.

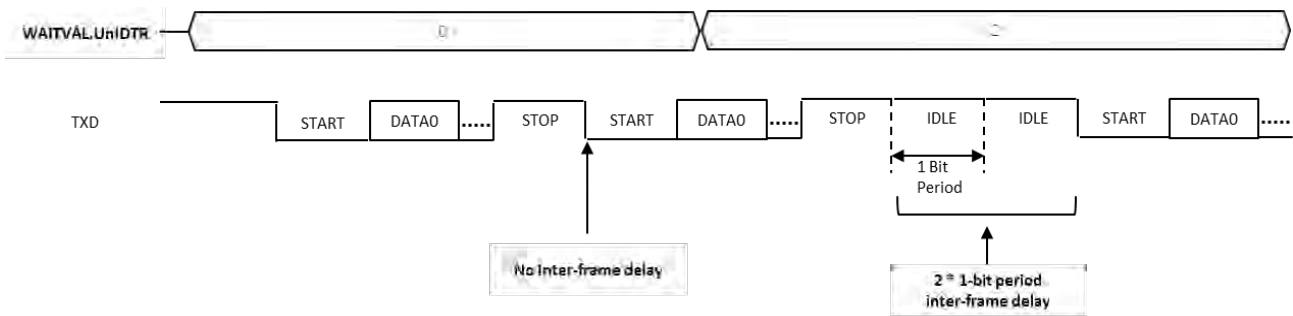

Figure 13.5. Inter-frame Delay Timing Diagram

Transmit Interrupt

The transmit operation generates interrupt flags. When the transmitter holding register is empty, the THRE interrupt flag is set. When the transmitter shifter register is empty, the TXE interrupt flag is set. Users can select which interrupt timing is best for the application.

Figure 13.6. Transmit Interrupt Timing Diagram

DMA Transfers

The UART supports the DMA interface function (optionally provided, depending on the device). The start memory address for transfer data and the length of transfer data are programmed in the registers in the DMA block.

The end of transfer is notified via the related transfer done flag.

Transmit with DMA operation invokes the DTX.UnIIR DMA TX done flag and sets the DMA TX done interrupt ID when all the transmit data are written to the transmit holding register. Two transmit data values remain in the registers of the UART block after the DMA transfer done interrupt.

Receive with DMA operation invokes the RXT.UnIIR DMA RX done flag and sets the DMA RX done interrupt ID when all the receive data are written to the destination memory. Therefore, the UART RXD signal is already in IDLE state when the DMA RX done interrupt is issued.

14. Serial Peripheral Interface

Overview

2-channel serial interfaces are provided for synchronous serial communications with external peripherals. The SPI block supports the master and slave modes. Four signals are used for SPI communication – SS, SCK, MOSI, and MISO.

- Master or Slave operation
- Programmable clock polarity and phase
- 8,9,16,17-bit wide transmit/receive register
- 8,9,16,17-bit wide data frame
- Loop-back mode
- Programmable start, burst, and stop delay time
- DMA handshake operation

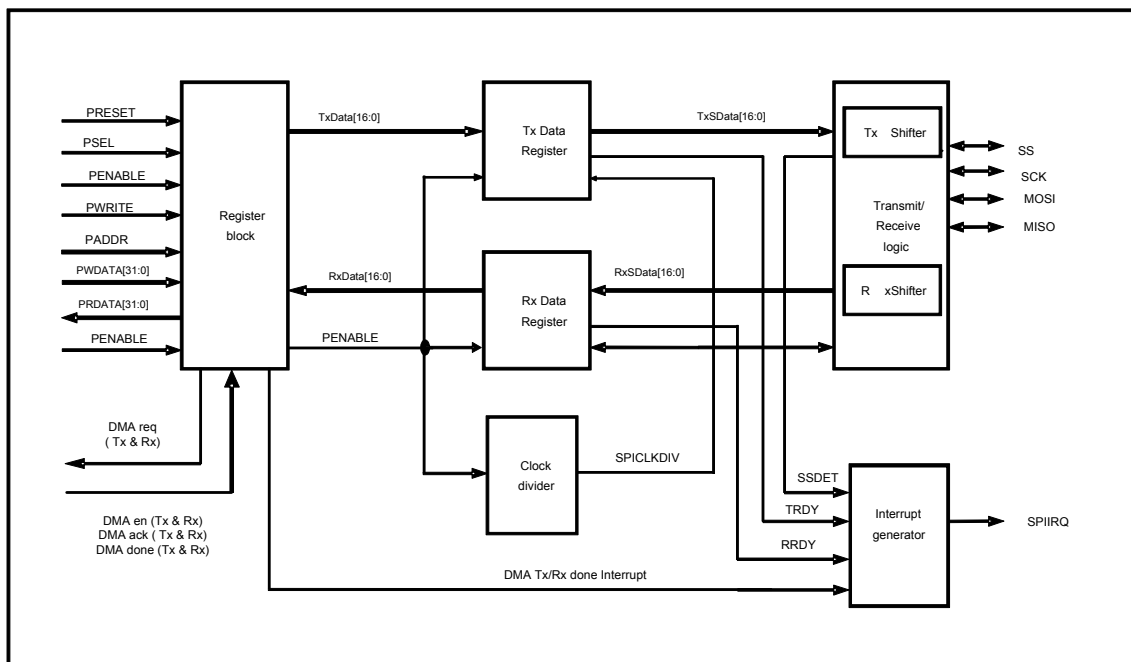

Figure 14.1. SPI Block Diagram

Pin Description

Table 14.1. External Pins

PIN NAME	TYPE	DESCRIPTION
SS0	I/O	SPI0 Slave select input / output
SCK0	I/O	SPI0 Serial clock input / output
MOSI0	I/O	SPI0 Serial data (Master output, Slave input)
MISO0	I/O	SPI0 Serial data (Master input, Slave output)
SS1	I/O	SPI1 Slave select input / output
SCK1	I/O	SPI1 Serial clock input / output
MOSI1	I/O	SPI1 Serial data (Master output, Slave input)
MISO1	I/O	SPI1 Serial data (Master input, Slave output)

Registers

The base address of SPI is 0x4000_9000 and the register map is described in Tables 14.2 and 14.3.

Table 14.2. SPI Base Address

Channel	Base address
SPI0	0x4000_9000
SPI1	0x4000_9100

Table 14.3 SPI Register Map

Name	Offset	TYPE	Description	Reset
SPn.TDR	0x--00	W	SPI n Transmit Data Register	-
SPn.RDR	0x--00	R	SPI n Receive Data Register	0x000000
SPn.CR	0x--04	R/W	SPI n Control Register	0x001020
SPn.SR	0x--08	R/W	SPI n Status Register	0x000006
SPn.BR	0x--0C	R/W	SPI n Baud rate Register	0x0000FF
SPn.EN	0x--10	R/W	SPI n Enable register	0x000000
SPn.LR	0x--14	R/W	SPI n delay Length Register	0x010101

SPn.CR SPI n Control Register

SPnCR is a 20-bit read/write register and can be set to configure SPI operation mode.

SP0.CR=0x4000_9004, SP1.CR=0x4000_9104

31	30	29	28	27	26	25	24	23	22	21	20	19	18	17	16	15	14	13	12	11	10	9	8	7	6	5	4	3	2	1	0
											TXBC	RXBC	DTXIE	DRXIE	SSCIE	TXIE	RXIE	SSMOD	SSOUT	LBE	SSMASK	SSMO	SSPOL			MS	MSBF	CPHA	CPOL		BITSZ
0	0	0	0	0	0	0	0	0	0	0	0	0	0	0	0	0	0	0	1	0	0	0	0	0	0	0	1	0	0	0	00
											RW	RW	RW	RW	RW	RW	RW	RW	RW	RW	RW	RW	RW			RW	RW	RW	RW	RW	

20	TXBC	Tx buffer clear bit. 0 No action 1 Clear Tx buffer
19	RXBC	Rx buffer clear bit 0 No action 1 Clear Rx buffer
18	DTXIE	DMA Tx Done Interrupt Enable bit. 0 DMA Tx Done Interrupt is disabled. 1 DMA Tx Done Interrupt is enabled.
17	DRXIE	DMA Rx Done Interrupt Enable bit. 0 DMA Rx Done Interrupt is disabled. 1 DMA Rx Done Interrupt is enabled.
16	SSCIE	nSS Edge Change Interrupt Enable bit. 0 nSS interrupt is disabled. 1 nSS interrupt is enabled for both edges (L→H, H→L)
15	TXIE	Transmit Interrupt Enable bit. 0 Transmit Interrupt is disabled. 1 Transmit Interrupt is enabled.
14	RXIE	Receive Interrupt Enable bit. 0 Receive Interrupt is disabled. 1 Receive Interrupt is enabled.
13	SSMOD	SS Auto/Manual output select bit. 0 SS output is not set by SSOUT (SPnCR[12]). - SS signal is in normal operation mode. 1 SS output signal is set by SSOUT.
12	SSOUT	SS output signal select bit. 0 SS output is 'L'. 1 SS output is 'H'.
11	LBE	Loop-back mode select bit in master mode. 0 Loop-back mode is disabled. 1 Loop-back mode is enabled.
10	SSMASK	SS signal masking bit in slave mode. 0 SS signal masking is disabled. - Receive data when SS signal is active. 1 SS signal masking is enabled. - Receive data at SCLK edges. SS signal is ignored.
9	SSMO	SS output signal select bit. 0 SS output signal is disabled. 1 SS output signal is enabled.
8	SSPOL	SS signal Polarity select bit. 0 SS signal is Active-Low. 1 SS signal is Active-High.
7		
6		Reserved

5	MS	Master/Slave select bit.
		0 SPI is in Slave mode.
		1 SPI is in Master mode.
4	MSBF	MSB/LSB Transmit select bit.
		0 LSB is transferred first.
		1 MSB is transferred first.
3	CPHA	SPI Clock Phase bit.
		0 Sampling of data occurs at odd edges (1,3,5,...,15).
		1 Sampling of data occurs at even edges (2,4,6,...,16).
2	CPOL	SPI Clock Polarity bit.
		0 Active-high clocks selected.
		1 Active-low clocks selected.
1	BITSZ	Transmit/Receive Data Bits select bit.
		00 8 bits
		01 9 bits
		10 16 bits
		11 17 bits
0		

CPOL=0, CPHA=0 : data sampling at rising edge, data changing at falling edge

CPOL=0, CPHA=1 : data sampling at falling edge, data changing at rising edge

CPOL=1, CPHA=0 : data sampling at falling edge, data changing at rising edge

CPOL=1, CPHA=1 : data sampling at rising edge, data changing at falling edge

SPn.SR SPI n Status Register

SPnSR is a 10-bits read/write register. It contains the status of SPI interface.

SP0.SR=0x4000_9008, SP1.SR=0x4000_9108															
15	14	13	12	11	10	9	8	7	6	5	4	3	2	1	0
						TXDMAF	RXDMAF	SBUSY	SSEDET	SSON	OVRF	UDRF	SRDY	TRDY	RRDY
0	0	0	0	0	0	0	0	0	0	0	0	0	1	1	0
						RC1	RC1	R	RC1	RC1	RC1	RC1	R	R	R

9	TXDMAF	DMA Transmit Operation Complete flag. (DMA to SPI) 0 DMA Transmit Op is working or is disabled. 1 DMA Transmit Op is done.
8	RXDMAF	DMA Receive Operation Complete flag. (SPI to DMA) 0 DMA Receive Operation is working or is disabled. 1 DMA Transmit Op is done.
8	SBUSY	Transmit/Receive Operation flag 0 SPI is in IDLE state 1 SPI is operating
6	SSEDET	The rising or falling edge of SS signal Detect flag. 0 SS edge is not detected. 1 SS edge is detected. - The bit is cleared when it is written as "0".
5	SSON	SS signal Status flag. 0 SS signal is inactive. 1 SS signal is active.
4	OVRF	Receive Overrun Error flag. 0 Receive Overrun error is not detected. 1 Receive Overrun error is detected. - This bit is cleared by writing or reading SPnRDR.
3	UDRF	Transmit Underrun Error flag. 0 Transmit Underrun is not occurred. 1 Transmit Underrun is occurred. - This bit is cleared by writing or reading SPnTDR.
2	SRDY	Shift register Empty flag. 0 Shift register is busy. 1 Shift register is ready. - This bit is cleared by writing SPnTDR to Shift register and is TRDY's complement when SSON is active.
1	TRDY	Transmit buffer Empty flag. 0 Transmit buffer is busy. 1 Transmit buffer is ready. - This bit is cleared by writing data to SPnTDR.
0	RRDY	Receive buffer Ready flag. 0 Receive buffer has no data. 1 Receive buffer has data. - This bit is cleared by writing data to SPnRDR.

SPn.TDR SPI n Transmit Data Register

SPnTDR is a 17-bit read/write register. It contains serial transmit data.

SP0.TDR=0x4000_9000, SP1.TDR=0x4000_9100

31	30	29	28	27	26	25	24	23	22	21	20	19	18	17	16	15	14	13	12	11	10	9	8	7	6	5	4	3	2	1	0	
																TDR																
0	0	0	0	0	0	0	0	0	0	0	0	0	0	0	0	0x00000																
																	RW															

16 **TDR** Transmit Data Register
 0

SPn.RDR SPI n Receive Data Register

SPnRDR is a 17-bit read/write register. It contains serial receive data.

SP0.RDR=0x4000_9000, SP1.RDR=0x4000_9100

31	30	29	28	27	26	25	24	23	22	21	20	19	18	17	16	15	14	13	12	11	10	9	8	7	6	5	4	3	2	1	0	
																RDR																
0	0	0	0	0	0	0	0	0	0	0	0	0	0	0	0	0x00000																
																	RW															

16 **RDR** Receive Data Register
 0

SPn.BR SPI n Baud Rate Register

SPnBR is an 16-bit read/write register. Baud rate can be set by writing to this register.

SP0.BR=0x4000_900C, SP1.BR=0x4000_910C

15	14	13	12	11	10	9	8	7	6	5	4	3	2	1	0
BR															
0x00FF															
RW															

15 **BR** Baud rate setting bits
 - Baud Rate = PCLK / (BR + 1).
 0 (BR must be bigger than "0", BR >= 2)

SPn.EN SPI n Enable Register

SPnEN is a single-bit read/write register. It contains SPI enable bit.

SP0.EN=0x4000_9010, SP1.EN=0x4000_9110

7	6	5	4	3	2	1	0
							ENABLE
0	0	0	0	0	0	0	0
							RW

0 ENABLE SPI Enable bit

- 0 SPI is disabled.
 - SPnSR is initialized by writing "0" to this bit but other registers aren't initialized.
- 1 SPI is enabled.
 - When this bit is written as "1", the dummy data of transmit buffer will be shifted. To prevent this, write data to SPTDR before this bit is active.

Note: When in SPI Slave mode, be sure to disable the SPI prior to loading the TDR register, then enable it to prevent an extra byte from being sent.

SPn.LR SPI n delay Length Register

SPnLR is a 24-bit read/write register. It contains start, burst, and stop length value.

SP0.CR=0x4000_9014, SP1.CR=0x4000_9114

31	30	29	28	27	26	25	24	23	22	21	20	19	18	17	16	15	14	13	12	11	10	9	8	7	6	5	4	3	2	1	0
								SPL								BTL								STL							
0 0 0 0 0 0 0 0								0x01								0x01								0x01							
								RW								RW								RW							

23	SPL	StoPLength value
0x01 ~ 0xFF : 1 ~ 255 SCLKs. (SPL >= 1)		
16		
15	BTL	BursTLength value
0x01 ~ 0xFF : 1 ~ 255 SCLKs. (BTL >= 1)		
8		
7	STL	STart Length value
0x01 ~ 0xFF : 1 ~ 255 SCLKs. (STL >= 1)		

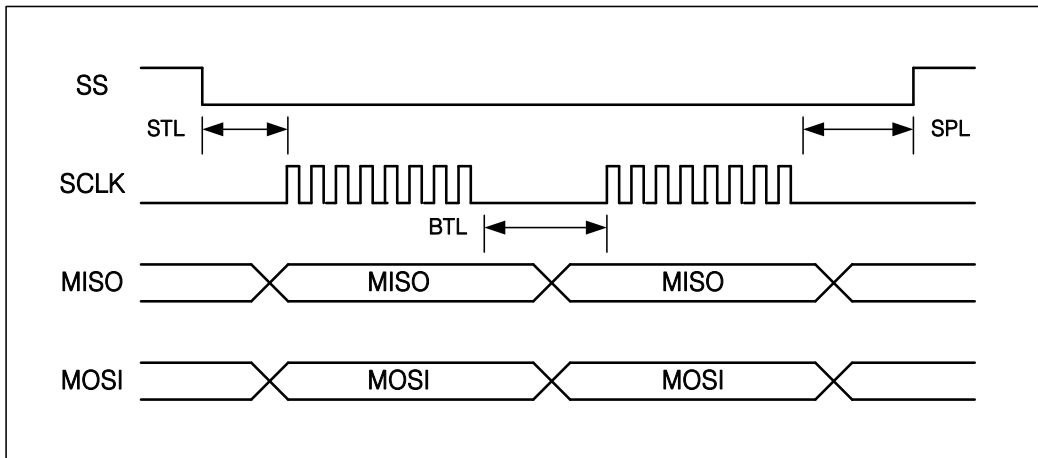

Figure14.1. SPI Waveform (STL, BTL, and SPL)

Functional Description

The SPI Transmit and Receive blocks share Clock Gen Block but they are independent of each other. The Transmit and Receive blocks have double buffers and SPI is available for back-to-back transfer operation.

SPI Timing

The SPI has four modes of operation. These modes essentially control the way data is clocked in or out of an SPI device. The configuration is done by two bits in the SPI control register (SPnCR). The clock polarity is specified by the CPOL control bit, which selects an active high or active low clock. The clock phase (CPHA) control bit selects one of the two fundamentally different transfer formats. To ensure effective communication between master and slave, both devices have to run in the same mode. This can require a reconfiguration of the master to match the requirements of different peripheral slaves.

The clock polarity has no significant effect on the transfer format. Switching this bit causes the clock signal to be inverted (active high becomes active low and idle low becomes idle high). The settings of the clock phase, however, select one of the two different transfer timings, which are described in the next two chapters. Since the MOSI and MISO lines of the master and the slave are directly connected to each other, the diagrams show the timing of both devices, master and slave. The nSS line is the slave select input of the slave. The nSS pin of the master is not shown in the diagrams. It has to be inactive by a high level on this pin (if configured as input pin) or by configuring it as an output pin.

The timing of a SPI transfer where CPHA is zero is shown in Figures 10.3 and 10.4. Two wave forms are shown for the SCK signal – one where CPOL equals zero and another where CPOL equals one.

When the SPI is configured as a slave, the transmission starts with the falling edge of the /SS line. This activates the SPI of the slave and the MSB of the byte stored in its data register (SPnTDR) is output on the MISO line. The actual transfer is started by a software write to the SPnTDR of the master. This causes the clock signal to be generated. If the CPHA equals zero, the SCLK signal remains zero for the first half of the first SCLK cycle. This ensures that the data is stable on the input lines of both the master and the slave. The data on the input lines is read with the edge of the SCLK line from its inactive to its active. The edge of the SCLK line from its active to its inactive state (falling edge if CPOL equals zero and rising edge if CPOL equals one) causes the data to be shifted one bit further so that the next bit is output on the MOSI and MISO lines.

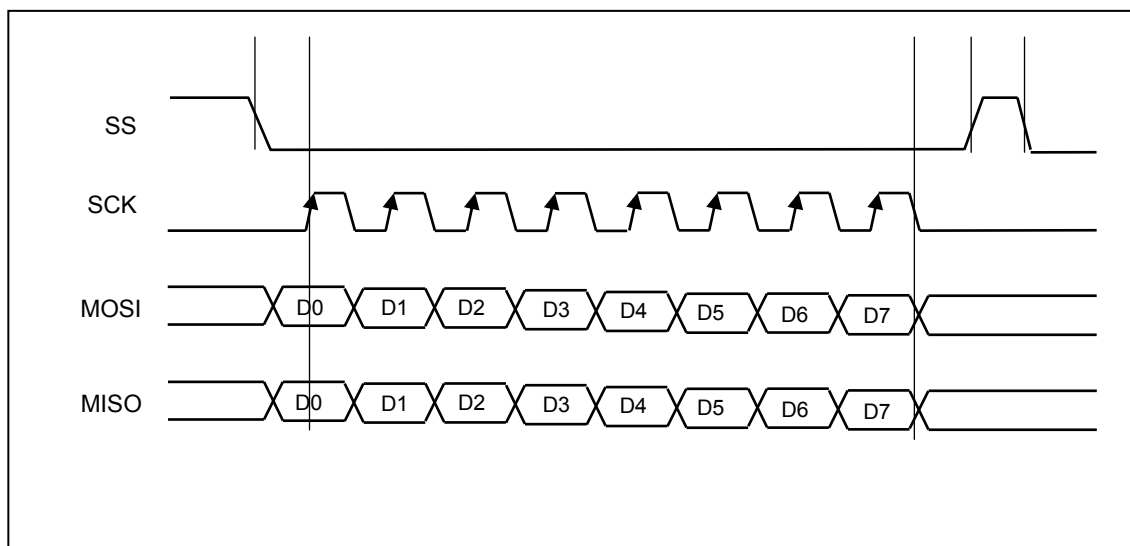

Figure 14.2.SPI Transfer Timing 1/4 (CPHA=0, CPOL=0, MSBF=0)

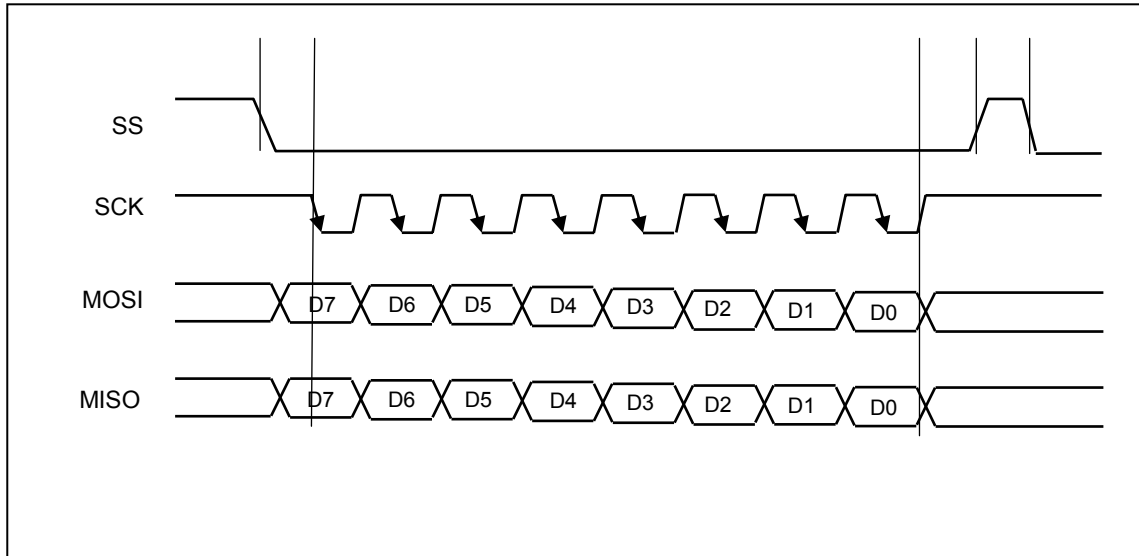

Figure 14.3.SPI Transfer Timing 2/4 (CPHA=0, CPOL=1, MSBF=1)

The timing of a SPI transfer where CPHA is one is shown in Figure 10.5 and 10.6. Two wave forms are shown for the SCLK signal – one when CPOL equals zero and another when CPOL equals one.

Similar to the previous case, the falling edge of the nSS lines selects and activates the slave. Compared to the previous case, where CPHA equals zero, the transmission is not started and the MSB is not output by the slave at this stage. The actual transfer is started by a software write to the SPnTDR of the master that causes the clock signal to be generated. The first edge of the SCLK signal from its inactive to its active state (rising edge if CPOL equals zero and falling edge if CPOL equals one) causes both the master and the slave to output the MSB of the byte in the SPnTDR.

As shown in Figures 14.3 and 14.4, there is no delay of half a SCLK-cycle. The SCLK line changes its level immediately at the beginning of the first SCLK-cycle. The data on the input lines is read with the edge of the SCLK line from its active to its inactive state (falling edge if CPOL equals zero and rising edge if CPOL equals one). After eight clock pulses the transmission is completed.

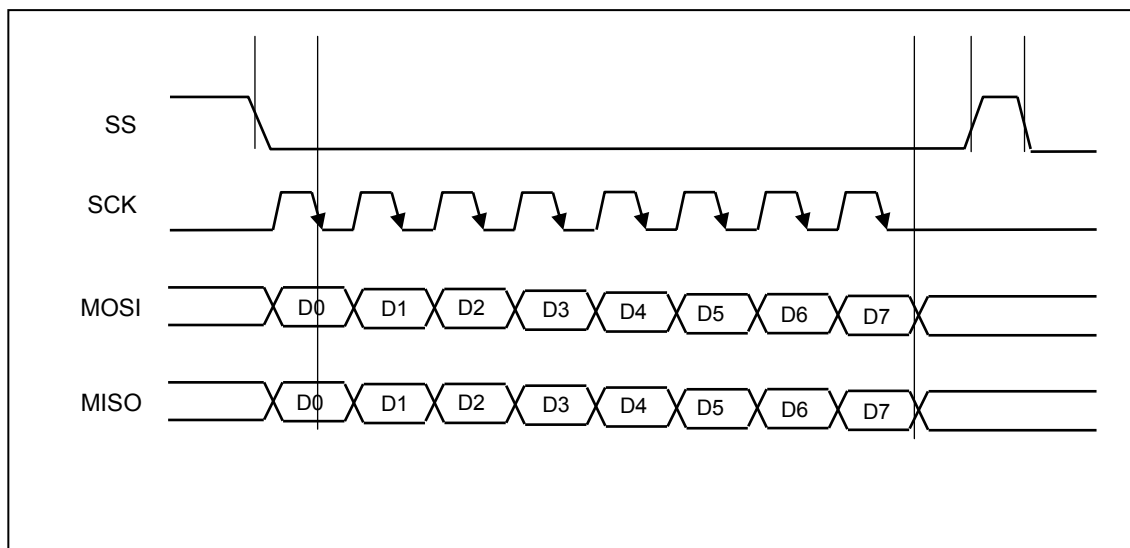

Figure 14.4.SPI Transfer Timing 3/4 (CPHA=1, CPOL=0, MSBF=0)

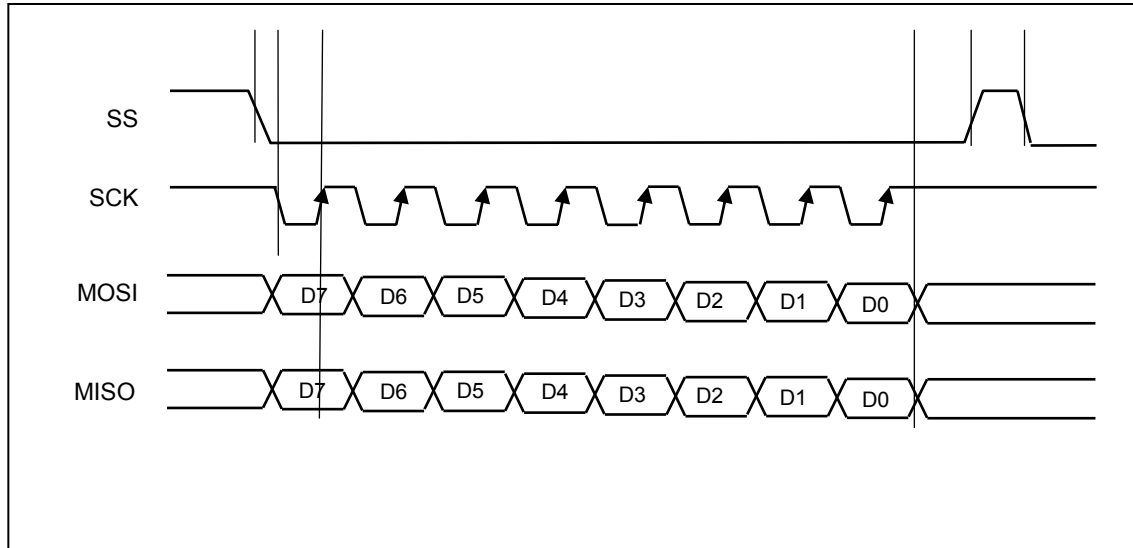

Figure 14.5.SPI Transfer Timing 4/4 (CPHA=1, CPOL=1, MSBF=1)

DMA Handshake

SPI supports DMA handshaking operation. In order to operate DMA handshake, DMA registers should be set first. (See Chapter 9. Direct Memory Access Controller). SPI0 has 2 channels of DMA, channel 8 for receiver and channel 9 for transmitter. SPI1 has channel 10 for receiver and channel 11 for transmitter. Because the transmitter and receiver are independent of each other, SPI can operate the two channels at the same time.

After the DMA channel for receiver is enabled and the receive buffer is filled, SPI sends Rx request to DMA to empty the buffer and waits for an ACK signal from DMA. If the Receive buffer is filled again after ACK signal, SPI sends an Rx request. If DMA Rx DONE becomes high, RXDMAF (SPnSR[8]) goes "1" and an interrupt is serviced when RXDIE (SPnCR[17]) is set.

Similarly, if the transmit buffer is empty after the DMA channel for transmitter is enabled, SPI sends a Tx request to DMA to fill the buffer and waits for an ACK signal from DMA. If the transmit buffer is empty again after the ACK signal, SPI sends a Tx request. If DMA Tx DONE becomes high, TXDMAF(SPnSR[9]) goes "1" and an interrupt is serviced when TXDIE(SPnCR[18]) is set.

The slave transmitter sends dummy data at the first transfer (8~17 SCLKs) in DMA handshake mode.

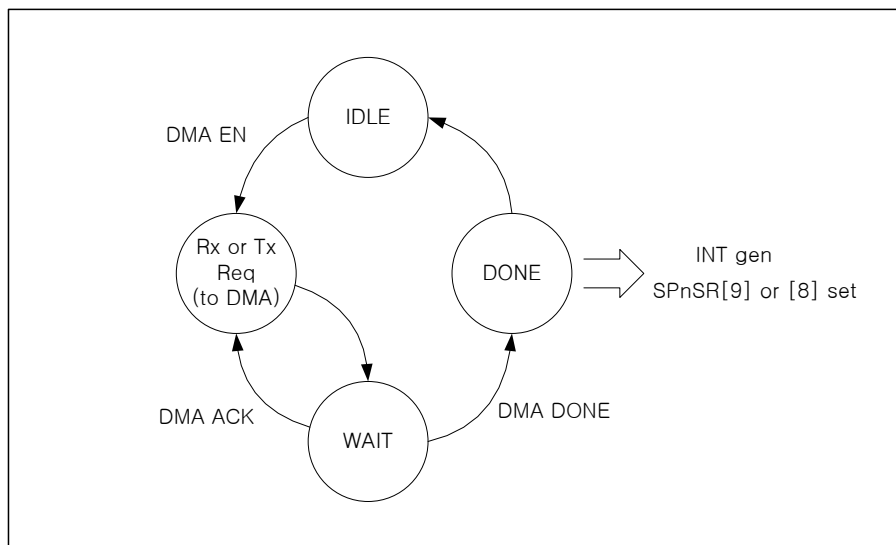

Figure 14.6.DMA Handshake Flowchart

15. I²C Interface

Overview

The Inter-Integrated Circuit (I²C) bus serves as an interface between the microcontroller and the serial I²C bus. It provides two wires and a serial bus interface to a large number of popular devices and allows parallel-bus systems to communicate bidirectionally with the I²C-bus.

- Master and slave operation
- Programmable communication speed
- Multi-master bus configuration
- 7-bit addressing mode
- Standard data rate of 100/400 kbps
- STOP signal generation and detection
- START signal generation
- ACK bit generation and detection

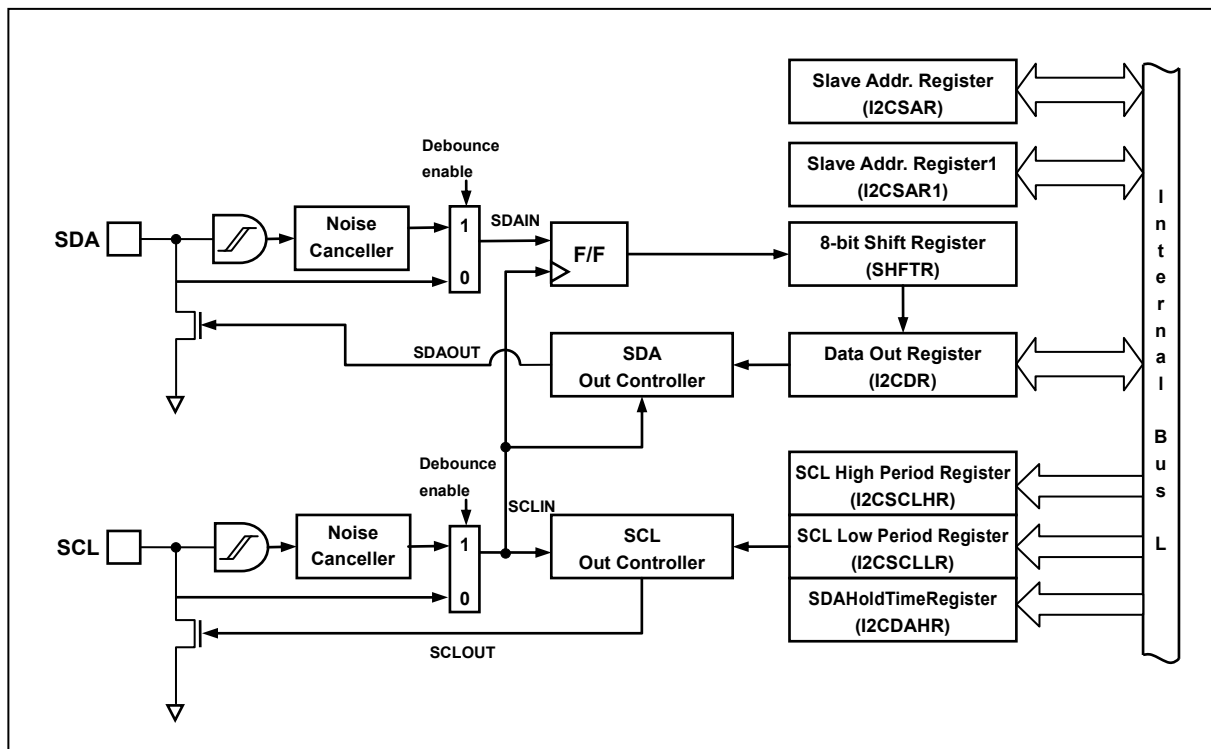

Figure 15.1. I²C Block Diagram

Pin Description

Table 15.1. I²C Interface External Pins

PIN NAME	TYPE	DESCRIPTION
SCL0	I/O	I ² C channel 0 Serial clock bus line (open-drain)
SDA0	I/O	I ² C channel 0 Serial data bus line (open-drain)
SCL1	I/O	I ² C channel 1 Serial clock bus line (open-drain)
SDA1	I/O	I ² C channel 1 Serial data bus line (open-drain)

Registers

The base address of I²C0 is 0x4000_A000 and the base address of I²C1 is 0x4000_A100. The register map is described in Tables 15.2 and 15.3.

Table 15.2. I²C Interface Base Address

Channel	Base address
I ² C0	0x4000_A000
I ² C1	0x4000_A100

Table 15.3. I²C Register Map

Name	Offset	R/W	Description	Reset
IC0.DR	0xA000	R/W	I ² C0 Data Register	0xFF
IC0.SR	0xA008	R, R/W	I ² C0 Status Register	0x00
IC0.SAR	0xA00C	R/W	I ² C0 Slave Address Register	0x00
IC0.CR	0xA014	R/W	I ² C0 Control Register	0x00
IC0.SCLL	0xA018	R/W	I ² C0 SCL LOW duration Register	0xFFFF
IC0.SCLH	0xA01C	R/W	I ² C0 SCL HIGH duration Register	0xFFFF
IC0.SDH	0xA020	R/W	I ² C0 SDA Hold Register	0x7F
IC1.DR	0xA100	R/W	I ² C1 Data Register	0xFF
IC1.SR	0xA108	R, R/W	I ² C1 Status Register	0x00
IC1.SAR	0xA10C	R/W	I ² C1 Slave Address Register	0x00
IC1.CR	0xA114	R/W	I ² C1 Control Register	0x00
IC1.SCLL	0xA118	R/W	I ² C1 SCL LOW duration Register	0xFFFF
IC1.SCLH	0xA11C	R/W	I ² C1 SCL HIGH duration Register	0xFFFF
IC1.SDH	0xA120	R/W	I ² C1 SDA Hold Register	0x007F

ICn.DR I²C Data Register

ICnDR is an 8-bit read/write register. It contains a byte of serial data to be transmitted or a byte which has just been received.

IC0.DR=0x4000_A000, IC1.DR=0x4000_A100,

7	6	5	4	3	2	1	0
ICDR							
0xFF							
RW							

7	ICDR	The most recently received data or data to be transmitted.
0		

ICn.SR I²C Status Register

ICnSR is an 8-bit read/write register. It contains the status of I²C bus interface. Writing to the register clears the status bits except for IMASTER.

IC0.SR=0x4000_A008, IC1.SR=0x4000_A008

7	6	5	4	3	2	1	0
GCALL	TEND	STOP	SSEL	MLOST	BUSY	TMODE	RXACK
0	0	0	0	0	0	0	0
RW	RW	RW	RW	RW	RW	RW	RW

7	GCALL	General call flag
		0 General call is not detected.
		1 General call detected.
6	TEND	1 Byte transmission complete flag
		0 The transmission is working or not completed.
		1 The transmission is completed.
5	STOP	STOP flag
		0 STOP is not detected.
		1 STOP is detected.
4	SSEL	Slave flag (Start condition received)
		0 Slave is not selected.
		1 Slave is selected.
3	MLOST	Mastership lost flag
		0 Mastership is not lost.
		1 Mastership is lost.
2	BUSY	BUSY flag
		0 I ² C bus is in IDLE state.
		1 I ² C bus is busy.
1	TMODE	Transmitter/Receiver mode flag
		0 Receiver mode.
		1 Transmitter mode.
0	RXACK	Rx ACK flag
		0 Rx ACK is not received.
		1 Rx ACK is received.

ICn.SAR I²C Slave Address Register

ICnSAR is an 8-bit read/write register. It shows the address in slave mode.

IC0.SAR=0x4000_A00C, IC1.SAR=0x4000_A10C

7	6	5	4	3	2	1	0
SVAD							GCEN
0x00							0
RW							RW

7	SVAD	7-bit Slave Address
1		
0	GCEN	General call enable bit
		0 General call is disabled.
		1 General call is enabled.

ICn.CR I²C Control Register

ICnCR is an 8-bit read/write register. The register can be set to configure I²C operation mode and simultaneously allows for I²C transactions to be kicked off.

IC0CR=0x4000_A014, IC1CR=0x4000_A114

15	14	13	12	11	10	9	8	7	6	5	4	3	2	1	0
						INTDEL		IIF	I2CEN	SOFTRST	INTEN	ACKEN		STOP	START
0	0	0	0	0	0	00		0	0	0	0	0	0	0	0
						RW		R	RW	RW	RW	RW		RW	RW

9	INTDEL	Interval delay value between address and data transfer (or DATA and DATA)
8		0 1 * ICnSCLL
		1 2 * ICnSCLL
		2 4 * ICnSCLL
		3 8 * ICnSCLL
7	IIF	Interrupt status bit
		0 Interrupt is inactive
		1 Interrupt is active
6	I2CEN	I2C enable bit
		0 I2C disabled
		1 I2C enabled
5	SOFTRST	Soft Reset enable bit.
		0 Soft Reset is disabled.
		1 Soft Reset is enabled..
4	INTEN	Interrupt enabled bit.
		0 Interrupt is disabled.
		1 Interrupt is enabled.
3	ACKEN	ACK enable bit in Receiver mode.
		0 ACK is not sent after receiving data.
		1 ACK is sent after receiving data.
1	STOP	Stop enable bit. When this bit is set as "1" in transmitter mode, next transmission will be stopped even though ACK signal has been received.
		0 Stop is disabled.
		1 Stop is enabled. When this bit is set, transmission will be stopped.
0	START	Transmission start bit in master mode.
		0 Waits in slave mode.
		1 Starts transmission in master mode.

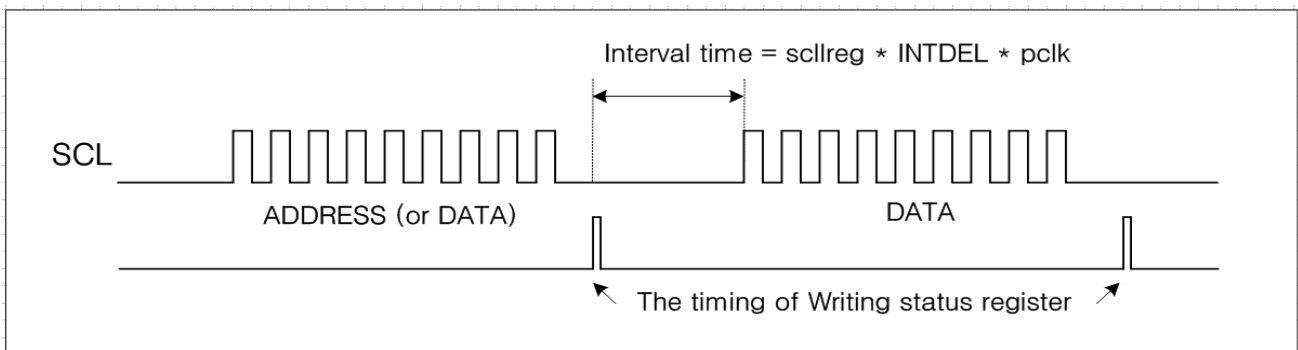

Figure15.1. INTDEL in Master Mode

ICn.SCLL I²C SCL LOW Duration Register

ICnSCLL is a 16-bit read/write register. The SCL LOW time is set by writing this register in master mode.

IC0.SDLL=0x4000_A018, IC1.SDLL=0x4000_A118															
15	14	13	12	11	10	9	8	7	6	5	4	3	2	1	0
SCLL															
0xFFFF															
RW															

15	SCLL	SCL LOW duration value. $SCLL = (PCLK * SCLL[15:0]) + 2 * PCLKs$
0		Default value is 0xFFFF.

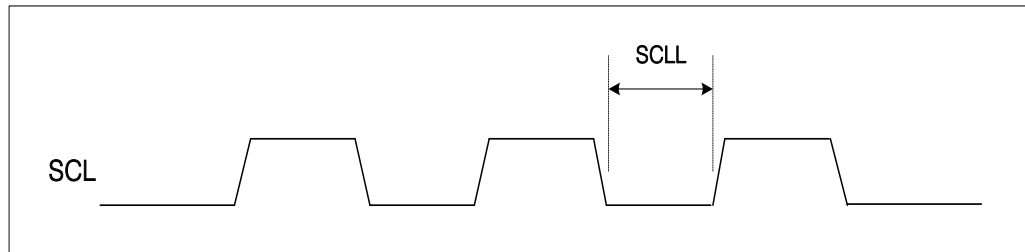

Figure 15.2. SCL LOW Timing

ICn.SCLH I²C SCL HIGH Duration Register

ICnSCLH is a 16-bit read/write register. The SCL HIGH time is set by writing this register in master mode.

IC0.SDLH=0x4000_A01C, IC1.SDLH=0x4000_A11C															
15	14	13	12	11	10	9	8	7	6	5	4	3	2	1	0
SCLH															
0xFFFF															
RW															

15	SCLH	SCL HIGH duration value. $SCLH = (PCLK * SCLH[15:0]) + 3 PCLKs$
0		Default value is 0xFFFF.

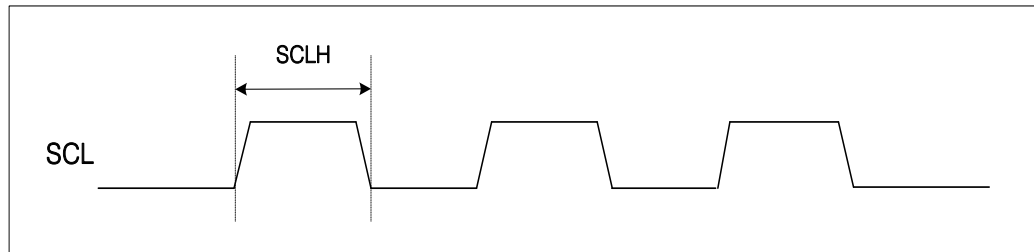

Figure 15.3.SCL HIGH Timing

ICn.SDH SDA Hold Register

ICnSDH is a 15-bit read/write register. The SDA HOLD time is set by writing this register in master mode.

IC0.SDH=0x4000_A020, IC1.SDH=0x4000_A120															
15	14	13	12	11	10	9	8	7	6	5	4	3	2	1	0
SDH															
0x007F															
RW															

14	SDH	SDA HOLD time setting value. $SDH = (PCLK * SDH[14:0]) + 4 PCLKs$
0		Default value is 0x3FFF.

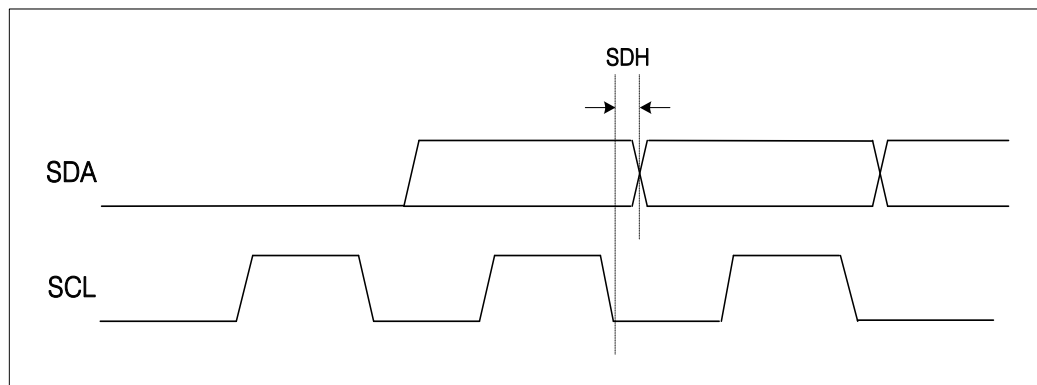

Figure 15.4. SDA HOLD Timing

Functional Description

I²C Bit Transfer

The data on the SDA line must be stable during the “H” period of the clock. The “H” or “L” state of the data line can only change when the clock signal on the SCL line is “L” as shown in Figure 15.5.

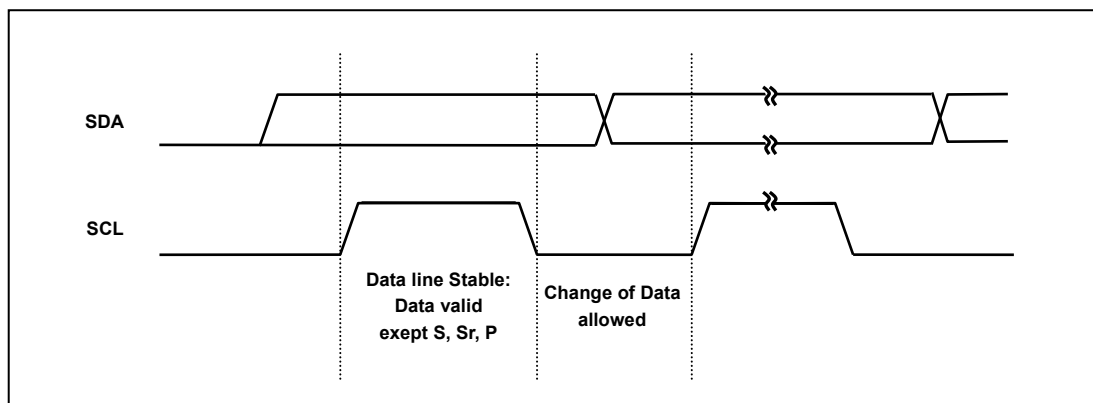

Figure 15.5. I²C Bus Bit Transfer

START/Repeated START/STOP

Within the procedure of the I²C-bus, unique situations arise which are defined as START(S) and STOP(P) conditions (see Figure 15.6.).

An “H” to “L” transition on the SDA line while SCL is “H” is one such unique case. This situation indicates a START condition.

An “L” to “H” transition on the SDA line while SCL is “H” defines a STOP condition.

START and STOP conditions are always generated by the master. The bus is considered to be busy after the START condition. The bus is considered to be free again a certain time after the STOP condition.

The bus is busy if a repeated START(Sr) is generated instead of a STOP condition. In this respect, the START(S) and repeated START(Sr) conditions are functionally identical. Therefore, for the remainder of this document, the S symbol will be used as a generic term to represent both the START and repeated START conditions, unless Sr is particularly relevant.

Detection of START and STOP conditions by devices connected to the bus is easy if they incorporate the necessary interfacing hardware. However, microcontrollers with no such interface have to sample the SDA line at least twice per clock period to sense the transition.

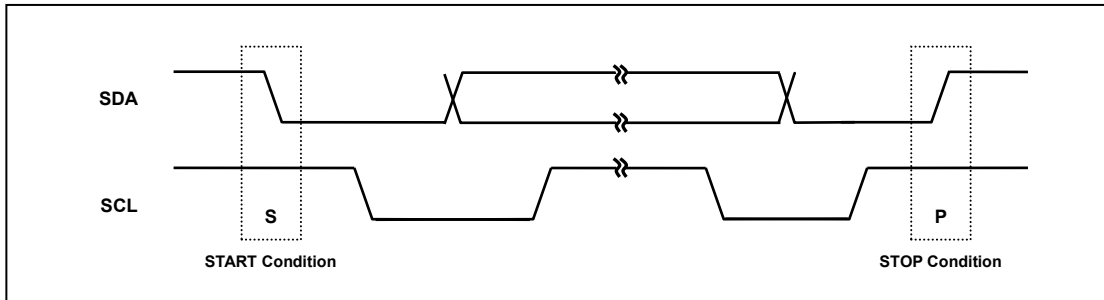

Figure 15.6. START and STOP Condition

Data Transfer

Every byte put on the SDA line must be 8-bit long. The number of bytes that can be transmitted per transfer is unrestricted. Each byte has to be followed by an acknowledge bit. Data is transferred with the most significant bit (MSB) first (see Figure 15.7). If a slave cannot receive or transmit another complete byte of data until it has performed some other function, for example servicing an internal interrupt, it can hold the clock line SCL “L” to force the master into a wait state. Data transfer then continues when the slave is ready for another byte of data and releases clock line SCL.

A message which starts with such an address can be terminated by generation of a STOP conditions, even during the transmission of a byte. In this case, no acknowledge is generated.

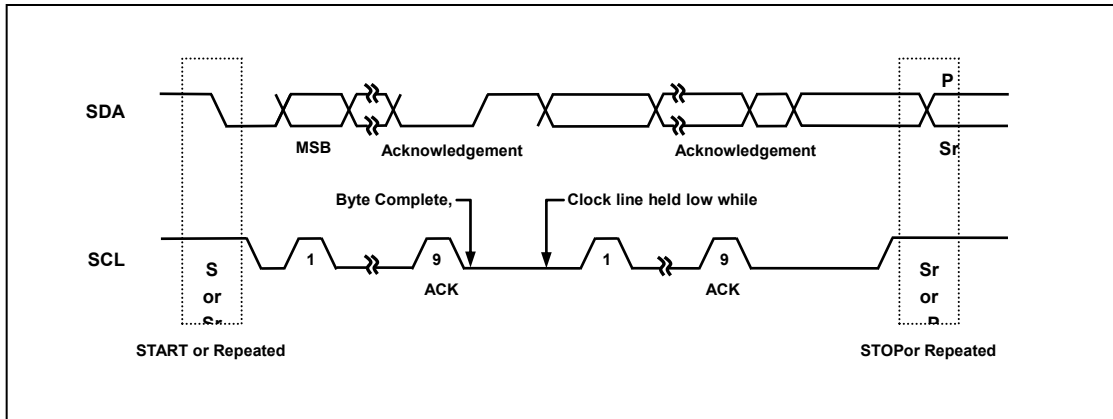

Figure 15.7. I²C Bus Data Transfer

Acknowledge

Data transfer with acknowledge is obligatory. The acknowledge-related clock pulse is generated by the master. The transmitter releases the SDA line (HIGH) during the acknowledge clock pulse.

The receiver must pull down the SDA line during the acknowledge clock pulse so that it remains stable “L” during the “H” period of this clock pulse (see Figure 15.8). Additionally, set-up and hold times must also be taken into account.

When a slave doesn’t acknowledge the slave address (for example, it’s unable to receive or transmit because it’s performing some real-time function), the data line must be left “H” by the slave. The master can then generate either a STOP condition to abort the transfer, or a repeated START condition to start a new transfer.

If a slave-receiver acknowledges the slave address, but later in the transfer cannot receive any more data bytes, the master must again abort the transfer. This is indicated by the slave generating the not-acknowledge on the first byte to follow. The slave leaves the data line “H” and the master generates a STOP or a repeated START condition.

If a master-receiver is involved in a transfer, it must signal the end of data to the slave-transmitter by not generating an acknowledge on the last byte that was clocked out of the slave. The slave-transmitter must release the data line to allow the master to generate a STOP or repeated START condition.

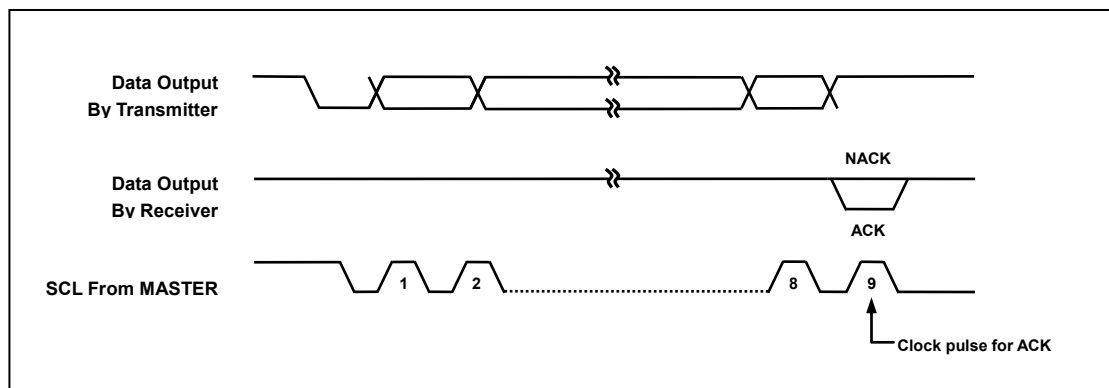

Figure 15.8. I²C Bus Acknowledge

Synchronization

All masters generate their own clock on the SCL line to transfer messages on the I²C-bus. Data is only valid during the “H” period of the clock. A defined clock is therefore needed for the bit-by-bit arbitration procedure to take place.

Clock synchronization is performed using the wired-AND connection of I²C interfaces to the SCL line. This means that an “H” to “L” transition on the SCL line will cause the devices to start counting off their “L” period and, after a device clock has gone “L”, it will hold the SCL line in that state until the clock “H” state is reached (see Figure 15.9). However, the “L” to “H” transition of this clock may not change the state of the SCL line if another clock is still within its “L” by the device with the longest “L” period. Devices with shorter “L” periods enter an “H” wait-state during this time.

When all devices have counted off their “L” period, the clock line will be released and go “H”. There will then be no difference between the device clocks and the state of the SCL line, and the devices will start counting their “H” periods. The first device to complete its “H” period will again pull the SCL line “L”.

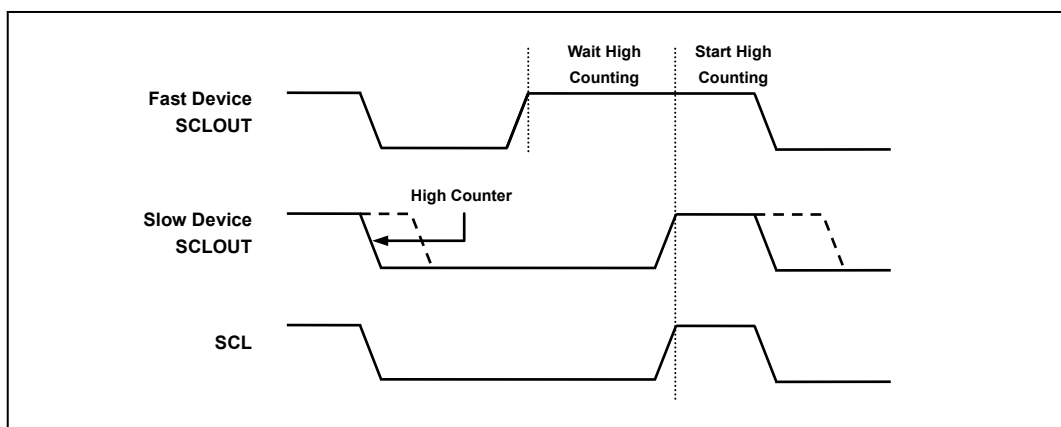

Figure 15.9. Clock Synchronization During the Arbitration Procedure

Arbitration

A master may start a transfer only if the bus is free. Two or more masters may generate a START condition within the minimum hold time of the START condition which results in a defined START condition to the bus.

Arbitration takes place on the SDA line, while the SCL line is at the “H” level, in such a way that the master which transmits “H” level, while another master is transmitting a “L” level will switch off its DATA output stage because the level on the bus doesn’t correspond to its own level.

Arbitration can continue for many bits. Its first stage is comparison of the address bits. If the masters are each trying to address the same device, arbitration continues with comparison of the data-bits if they are master-transmitter, or acknowledge-bits if they are master-receiver. Because address and data information on the I²C-bus is determined by the winning master, no information is lost during the arbitration process.

A master that loses the arbitration can generate clock pulses until the end of the byte in which it loses the arbitration.

If a master also incorporates a slave function and it loses arbitration during the addressing stage, it is possible that the winning master is trying to address it. The losing master must therefore switch over immediately to its slave mode.

Figure 15.10 shows the arbitration procedure for two masters. There may be additional masters involved, depending on how many masters are connected to the bus. As soon as there is a difference between the internal data level of the master generating Device1 Dataout and the actual level on the SDA line, its data output is switched off, which means that an “H” output level is then connected to the bus. This will not affect the data transfer initiated by the winning master.

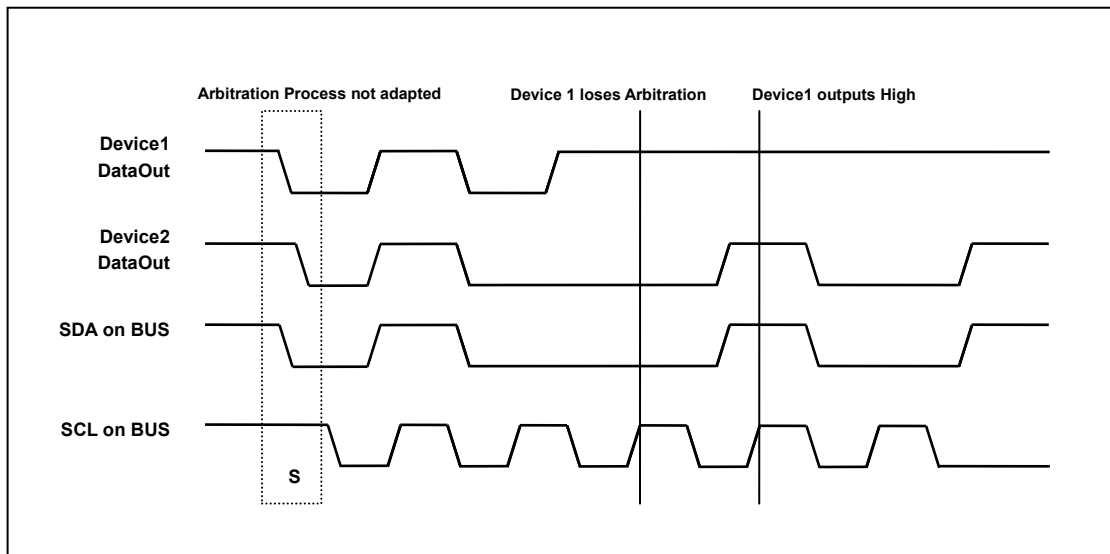

Figure 15.10. Arbitration Procedure of Two Masters

I²C OPERATION

I²C supports interrupt operation. After the interrupt is serviced, the IIF(ICnSR[10]) flag is set. ICnSR shows I²C-bus status information and the SCL line stays "L" before the register is written as a certain value. The status register can be cleared by writing any value to the status register.

Master Transmitter

The master transmitter shows the flow of the transmitter in Master mode as shown in Figure 15.11.

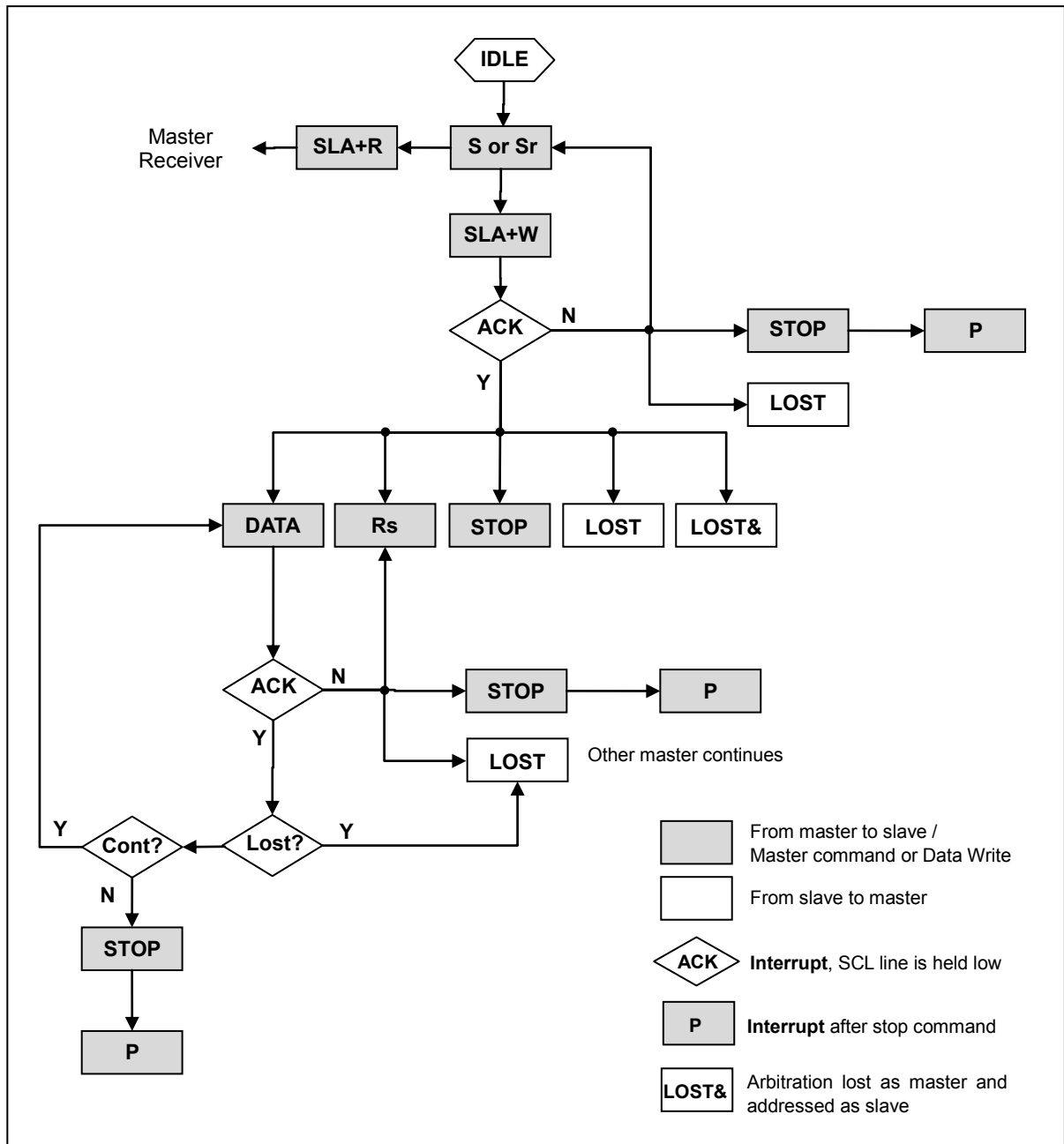

Figure 15.11. Transmitter Flowchart in Master Mode

Master Receiver

The master receiver shows the flow of the receiver in Master mode as shown in Figure 15.12.

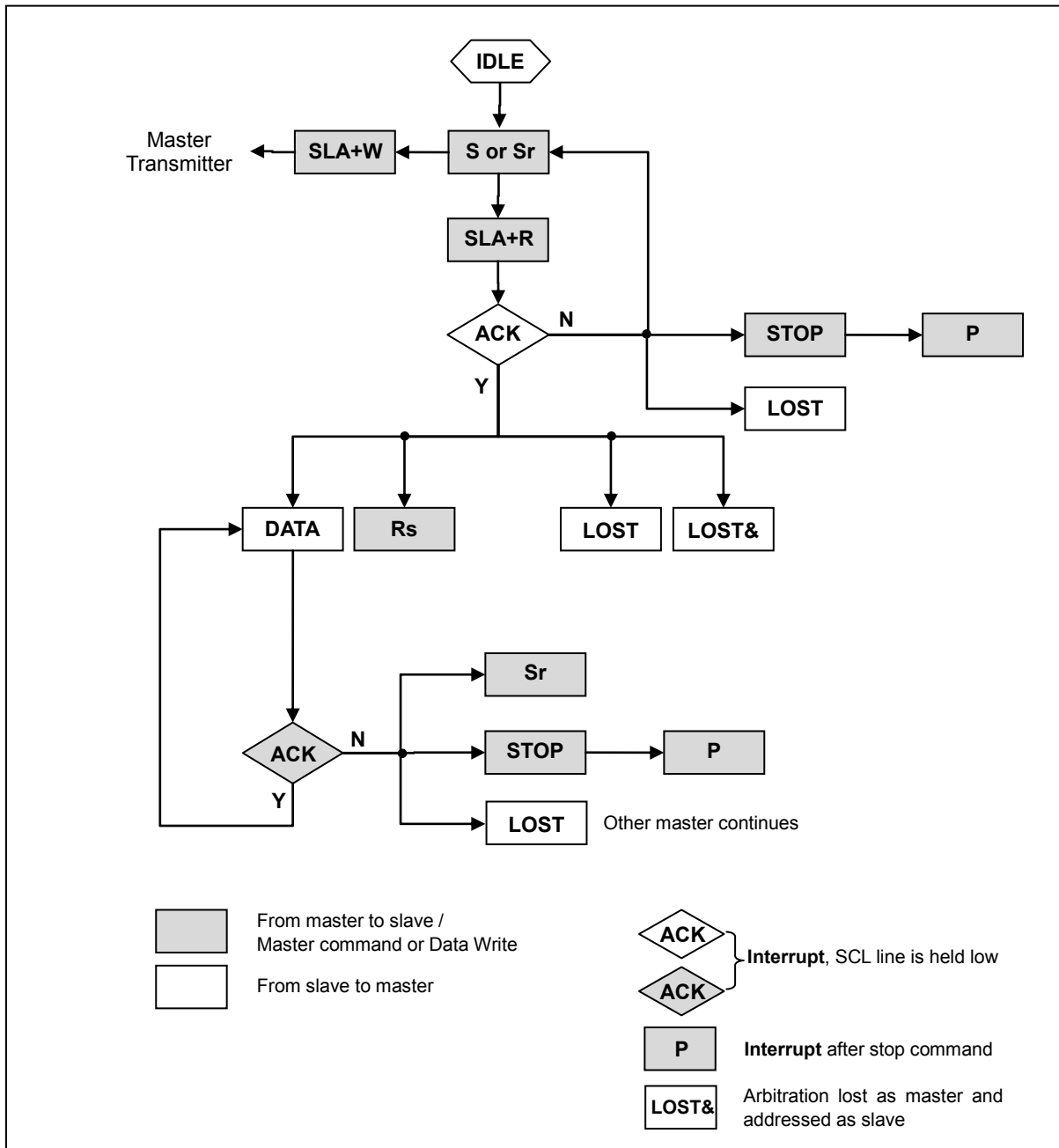

Figure 15.12. Receiver Flowchart in Master Mode

Slave Transmitter

The slave transmitter shows the flow of the transmitter in Slave mode, as shown in Figure 15.13.

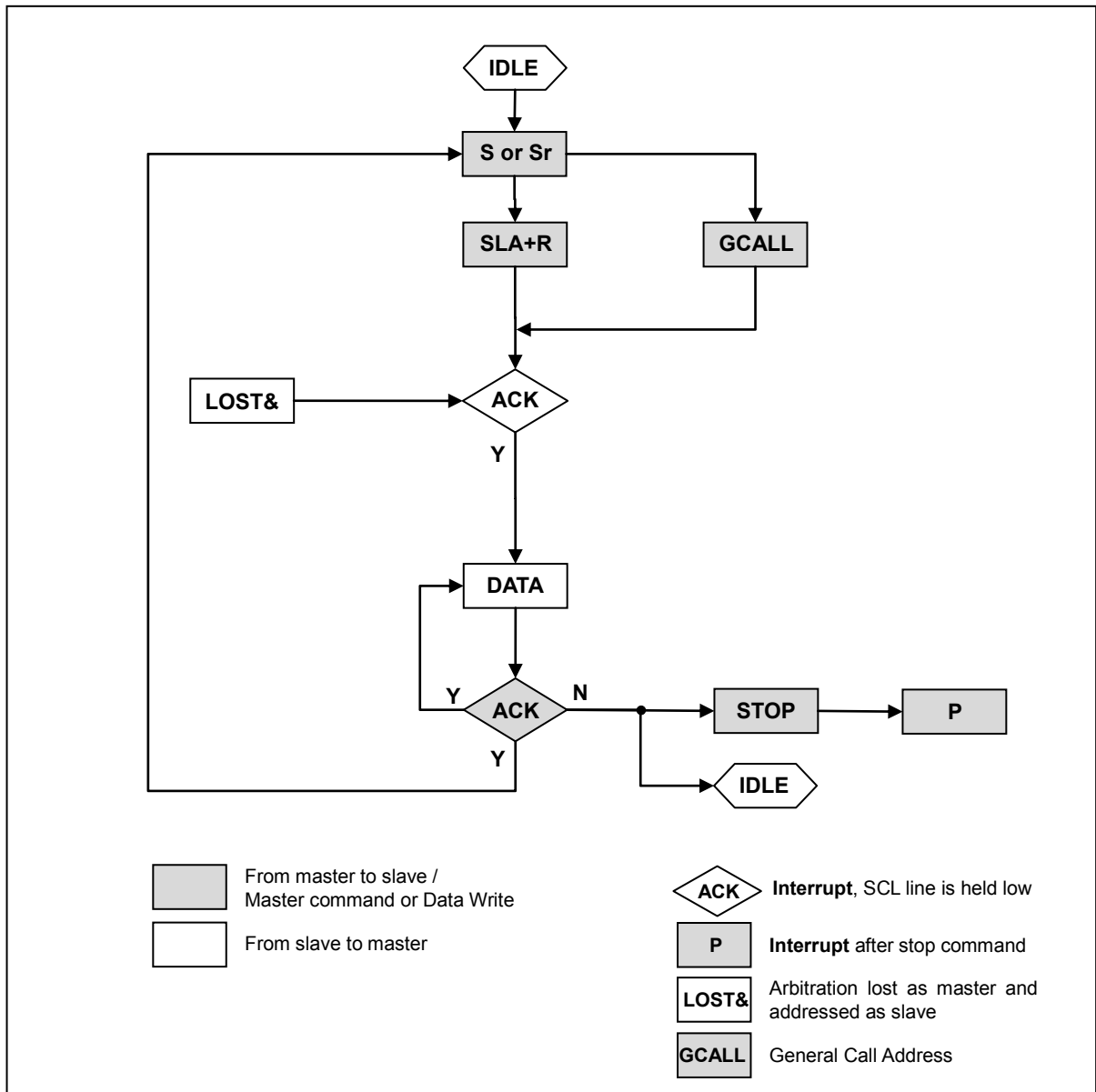

Figure 15.13. Transmitter Flowchart in Slave Mode

Slave Receiver

The slave receiver shows the flow of the receiver in Slave mode, as shown in Figure 15.14.

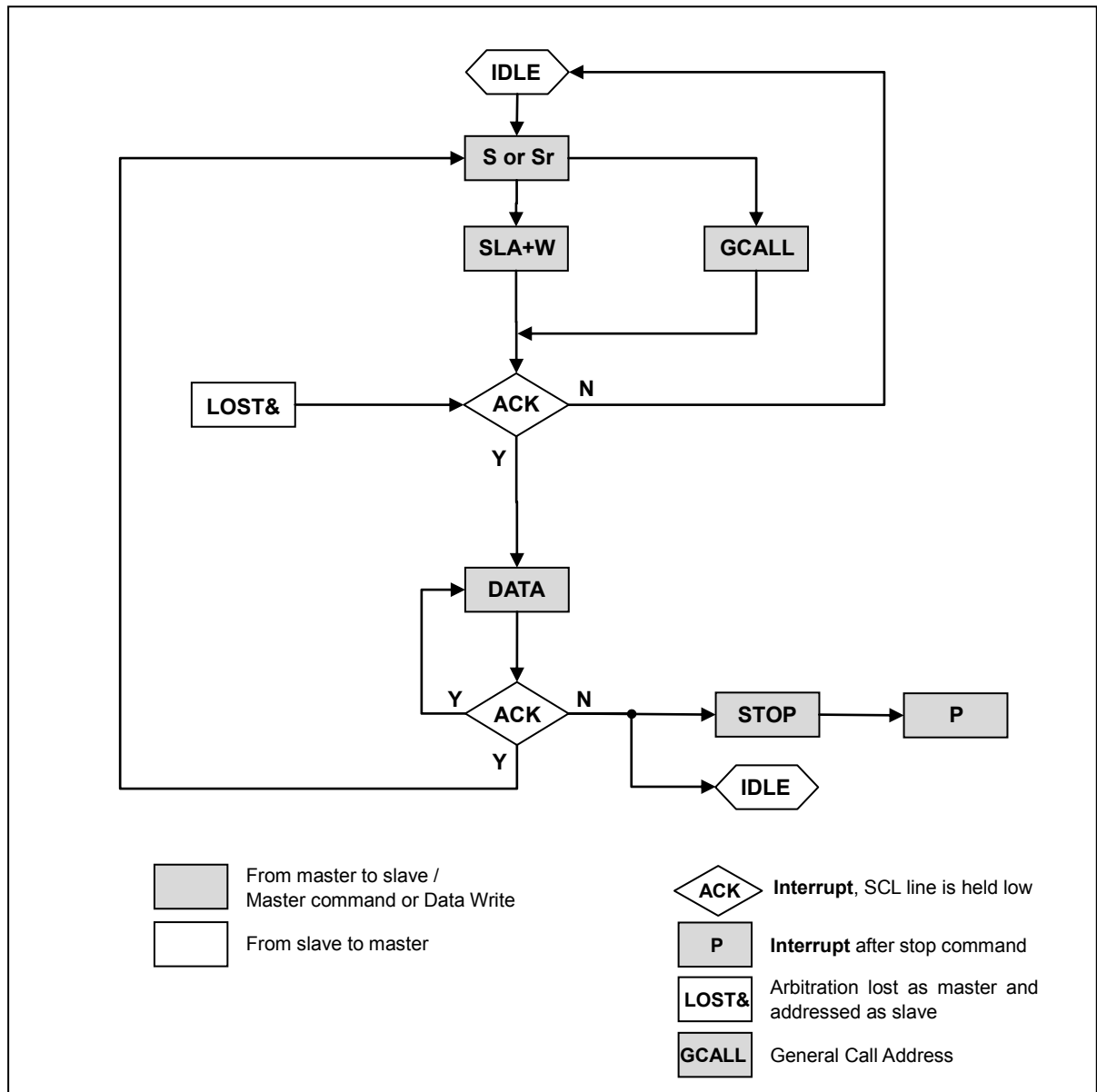

Figure 15.14. Receiver Flowchart in Slave Mode

16. Motor Pulse-Width-Modulator

Introduction

The Motor Pulse Width Modulator (MPWM) is a programmable motor controller which is optimized for 3-phase inverter control applications. It can be used in several other applications that require timing, counting, and comparison.

MPWM includes three channels, each of which controls a pair of outputs that in turn can control an AC or DC motor through an inverter bridge. Features include:

- 6 channel outputs for motor control
- Dead- time zone support
- Protection event and over voltage event handling
- 6 trigger outputs for ADC
- Interval interrupt mode
- Up-down count mode

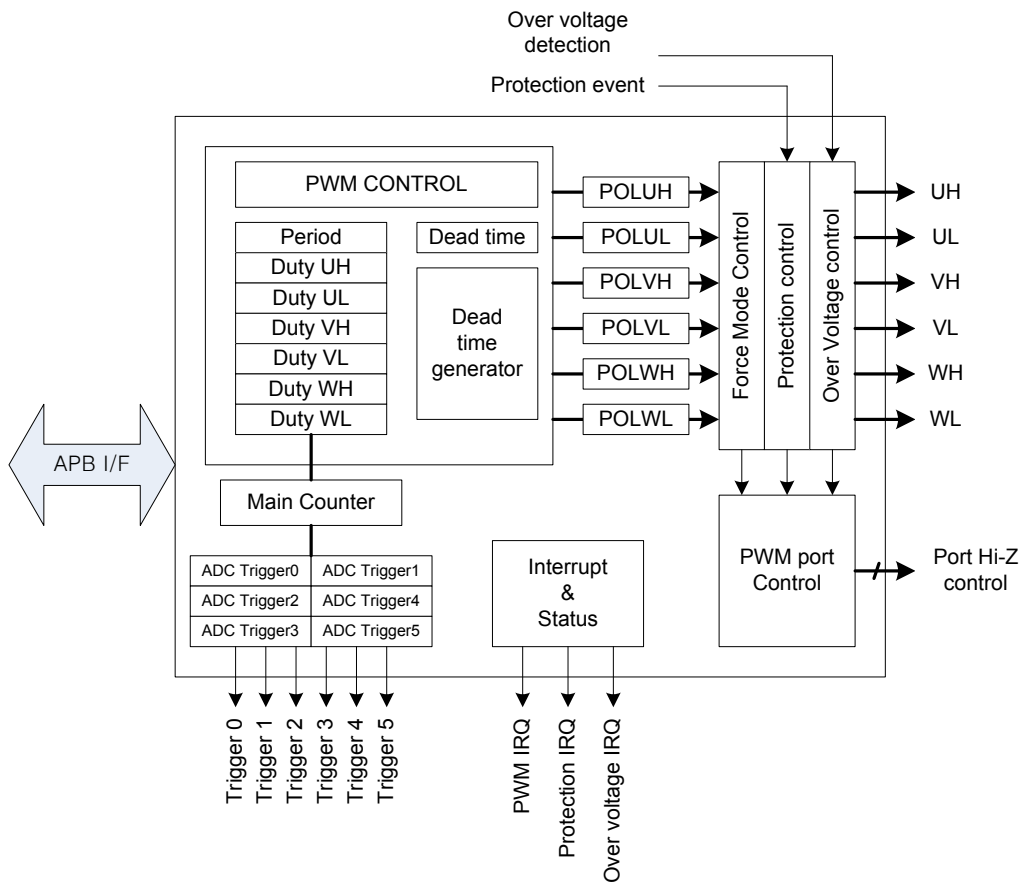

Figure 16.1. Block Diagram

Pin Description

Table16.1. External Signals

PIN NAME	TYPE	DESCRIPTION
MP0UH	O	MPWM 0 Phase-U H-side output
MP0UL	O	MPWM 0 Phase-ULH-side output
MP0VH	O	MPWM 0 Phase-V H-side output
MP0VL	O	MPWM 0 Phase-V L-side output
MP0WH	O	MPWM 0 Phase-W L-side output
MP0WL	O	MPWM 0 Phase-W L-side output
MP1UH	O	MPWM 1 Phase-U H-side output
MP1UL	O	MPWM 1 Phase-U L-side output
MP1VH	O	MPWM 1 Phase-V H-side output
MP1VL	O	MPWM 1 Phase-V L-side output
MP1WH	O	MPWM 1 Phase-W L-side output
MP1WL	O	MPWM 1 Phase-W L-side output
PRTIN0	I	MPWM 0 Protection Input
OVIN0	I	MPWM 0 Over-voltage Input
PRTIN1	I	MPWM 1 Protection Input
OVIN1	I	MPWM 1 Over-voltage Input

Registers

The base address of MPWM is Table 16.2.

Table16.2. MPWM Base Address

	BASE ADDRESS
MPWM0	0x4000_4000
MPWM0	0x4000_5000

Table 16.3 shows the register memory map.

Table16.3. MPWM Register Map

Name	Offset	R/W	Description	Reset
MPn.MR	0x0000	R/W	PWM Mode register	0x0000_0000
MPn.OLR	0x0004	R/W	PWM Output Level register	0x0000_0000
MPn.FOR	0x0008	R/W	PWM Force Output register	0x0000_0000
MPn.PRD	0x000C	R/W	PWM Period register	0x0000_0002
MPn.DUH	0x0010	R/W	PWM Duty UH register	0x0000_0001
MPn.DVH	0x0014	R/W	PWM Duty VH register	0x0000_0001
MPn.DWH	0x0018	R/W	PWM Duty WH register	0x0000_0001
MPn.DUL	0x001C	R/W	PWM Duty UL register	0x0000_0001
MPn.DVL	0x0020	R/W	PWM Duty VL register	0x0000_0001
MPn.DWL	0x0024	R/W	PWM Duty WL register	0x0000_0001
MPn.CR1	0x0028	R/W	PWM Control register 1	0x0000_0000
MPn.CR2	0x002C	R/W	PWM Control register 2	0x0000_0000
MPn.SR	0x0030	R	PWM Status register	0x0000_0000
MPn.IER	0x0034	R/W	PWM Interrupt Enable	0x0000_0000
MPn.CNT	0x0038	R	PWM counter register	0x0000_0001
MPn.DTR	0x003C	R/W	PWM dead time control	0x0000_0000
MPn.PCR0	0x0040	R/W	PWM protection 0 control register	0x0000_0000
MPn.PSR0	0x0044	R/W	PWM protection 0 status register	0x0000_0080
MPn.PCR1	0x0048	R/W	PWM protection 1 control register	0x0000_0000
MPn.PSR1	0x004C	R/W	PWM protection 1 status register	0x0000_0000
-	0x0054	-	Reserved	-
MPn.ATR1	0x0058	R/W	PWM ADC Trigger reg1	0x0000_0000
MPn.ATR2	0x005C	R/W	PWM ADC Trigger reg2	0x0000_0000
MPn.ATR3	0x0060	R/W	PWM ADC Trigger reg3	0x0000_0000
MPn.ATR4	0x0064	R/W	PWM ADC Trigger reg4	0x0000_0000
MPn.ATR5	0x0068	R/W	PWM ADC Trigger reg5	0x0000_0000
MPn.ATR6	0x006C	R/W	PWM ADC Trigger reg6	0x0000_0000

MPn.MR MPWM Mode Register

The PWM operation Mode register is a 16-bit register.

MP0.MR=0x4000_4000, MP1.MR=0x4000_5000															
15	14	13	12	11	10	9	8	7	6	5	4	3	2	1	0
MOTORB								UAO		TUP	BUP		MCHMOD		UPDOWN
0										0	0		00		0
R/W								R/W		R/W	R/W		RW		R/W

15	MOTORB	Set PWM Mode
		0 Motor Mode
		1 Normal (PWM) mode
7	UAO	0 Update will be executed at designated timing.
		1 Update all duty, period register at once. When UPDATE set, Duty and Period registers are updated after two PWM clocks
5	TUP	0 Period, duty values are not updated at every period match.
		1 Period, duty values are updated at every period match.
4	BUP	0 Period, duty values are not updated at every bottom match
		1 Period, duty values are updated at every bottom match
2	MCHMOD	00 2 channels symmetric mode Duty H decides toggle high/low time of H-ch Duty L decides toggle high/low time of L-ch
1		01 1 channel asymmetric mode Duty H decides toggle high time of H-ch Duty L decides toggle low time of H-ch L channel become the inversion of H channel
		10 1 channel symmetric mode Duty H decides toggle high/low time of H-ch L channel become the inversion of H channel
		11 Not valid (same with 00)
0	UPDOWN	0 PWM Up count mode (only in Normal mode)
		1 PWM Up/Down count mode

After initial PWM period and duty setting is completed, the UAO bit should be set once for updating the setting value into the internal operating registers. This action will help to transfer the setting data from the user interface register to the internal operating register. The UAO bit should stay at the set state for at least 2-PWM clock periods. Otherwise, the update command can be missed and internal registers will retain the previous data.

MCHMOD in the MPn.MR field is only effective when MOTORB in MPn.MR is clear "0". Otherwise, the MCHMOD field value will be ignored internally and will keep the "00" value.

UPDOWN in the MPn.MR field is only effective when MOTORB in MPn.MR is set to "1". Otherwise, the UPDOWN field value will be ignored internally and will keep the "1" value. In the motor mode, the counter is always updown count operation.

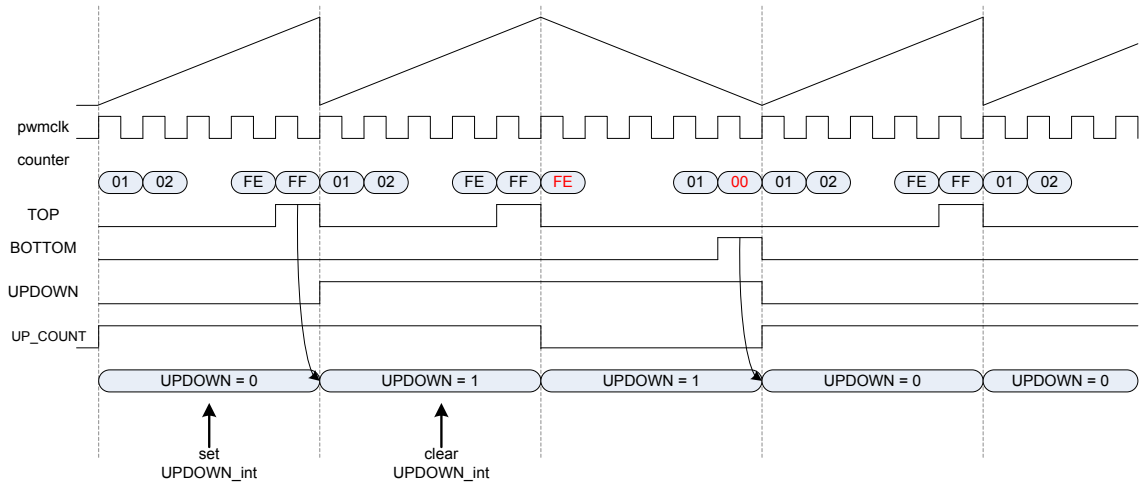

MPn.OLR **MPWM Output Level Register**

PWM Port Mode register is a 16-bit register.

MP0.OLR=0x4000_4004, MP1.OLR=0x4000_5004

7	6	5	4	3	2	1	0
		WHL	VHL	UHL	WLL	VLL	ULL
0	0	0	0	0	0	0	0
		RW	RW	RW	RW	RW	RW

WHL	0	Normal Output = L / Active Output = H
	1	Normal Output = H / Active Output = L
VHL	0	Normal Output = L / Active Output = H
	1	Normal Output = H / Active Output = L
UHL	0	Normal Output = L / Active Output = H
	1	Normal Output = H / Active Output = L
WLL	0	Normal Output = L / Active Output = H
	1	Normal Output = H / Active Output = L
VLL	0	Normal Output = L / Active Output = H
	1	Normal Output = H / Active Output = L
ULL	0	Normal Output = L / Active Output = H
	1	Normal Output = H / Active Output = L

Table 16.1. MPWM Register Map

PWM Output	Level	NORMAL mode		MOTOR mode
		UP mode	UPDOWN mode	
WH	Default level	LOW	HIGH	LOW
	Active level	HIGH	LOW	HIGH
WL	Default level	LOW	LOW	HIGH
	Active level	HIGH	HIGH	LOW
VH	Default level	LOW	HIGH	LOW
	Active level	HIGH	LOW	HIGH
VL	Default level	LOW	LOW	HIGH
	Active level	HIGH	HIGH	LOW
UH	Default level	LOW	HIGH	LOW
	Active level	HIGH	LOW	HIGH
UL	Default level	LOW	LOW	HIGH
	Active level	HIGH	HIGH	LOW

Figure 16.2 shows the polarity control block. This is an example of WH signal polarity control.

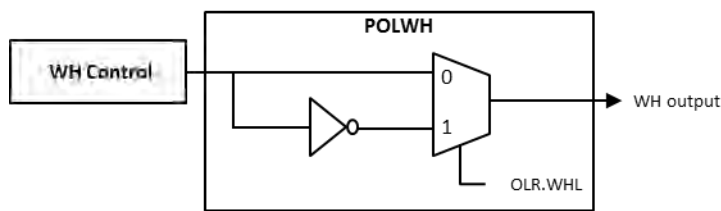

Figure 16.2 Polarity Control Block

MPn.FOR MPWM Force Output Level Register

The PWM force output register is an 8-bit register. The PWM output level can be forced by an abnormal event from an external or user-intended condition. When the forced condition occurs, each PWM output level which is programmed in the FOLR register will be forced.

MP0.FOR=0x4000_4008, MP1.FOR=0x4000_5008,

7	6	5	4	3	2	1	0
		WHFL	VHFL	UHFL	WLFL	VLFL	ULFL
0	0	0	0	0	0	0	0
		RW	RW	RW	RW	RW	RW

5	WHFL	Select WH Output Force Level 0 Output Force Level is 'L' 1 Output Force Level is 'H'
4	VHFL	Select VH Output Force Level 0 Output Force Level is 'L' 1 Output Force Level is 'H'
3	UHFL	Select UH Output Force Level 0 Output Force Level is 'L' 1 Output Force Level is 'H'
2	WLFL	Select WL Output Force Level

		0	Output Force Level is 'L'
		1	Output Force Level is 'H'
1	VLFL	Select VL Output Force Level	
		0	Output Force Level is 'L'
		1	Output Force Level is 'H'
0	ULFL	Select UL Output Force Level	
		0	Output Force Level is 'L'
		1	Output Force Level is 'H'

MPn.CR1 MPWM Control Register 1

PWM Control Register 1 is a 16-bit register.

MP0.CR1=0x4000_4028, MP1.CR1=0x4000_5028

15	14	13	12	11	10	9	8	7	6	5	4	3	2	1	0
							IRQN								PWMEN
							000		0	0	0	0	0	0	0
							RW								RW

10	IRQN	IRQ interval number (Every 1~8th PRDIRQ,BOTIRQ,ATRn)
8		
0	PWMEN	PWM enable When this bit is set to 0, the PWM block stays in the reset state but the user interface can be accessed. To operate the PWM block, this bit should be set to 1.

MPn.CR2 MPWM Control Register 2

PWM Control Register 2 is an 8-bit register.

MP0.CR2=0x4000_402C, MP1.CR2=0x4000_502C,

7	6	5	4	3	2	1	0
HALT							PSTART
0	0	0	0	0	0	0	0
RW							RW

7	HALT	PWM HALT (PWM counter stop but not reset) PWM outputs keep previous state
0	PSTART	0 PWM counter stop and clear 1 PWM counter start (will be resynced @PWM clock twice)
PWMEN should be "1" to start PWM counter		

MPn.PRD MPWM Period Register

PWM Period Register is a 16-bit register.

MP0.PRD=0x4000400C, MP1.PRD=0x40000500C

15	14	13	12	11	10	9	8	7	6	5	4	3	2	1	0
PERIOD															
0x0002															
R/W															

15:0	PERIOD	16-bit PWM period. It should be larger than 0x0010 (if Duty is 0x0000, PWM will not work)
------	---------------	---

MPn.DUH MPWM Duty UH Register

PWM U channel duty register is an 16-bit register.

MP0DUH=0x4000_4010, MP1DUH=0x4000_5010

15	14	13	12	11	10	9	8	7	6	5	4	3	2	1	0
DUTY UH															
0x0001															
R/W															

15:0	DUTY UH	16-bit PWM Duty for UH output. It should be larger than 0x0001 (if Duty is 0x0000, PWM will not work)
------	----------------	---

MPn.DVH MPWM Duty VH Register

PWM V channel duty register is a 16-bit register.

MP0.DVH=0x4000_4014, MP1DVH=0x4000_5014

15	14	13	12	11	10	9	8	7	6	5	4	3	2	1	0
DUTY VH															
0x0001															
R/W															

15:0	DUTY VH	16-bit PWM Duty for VH output. It should be larger than 0x0001 (if Duty is 0x0000, PWM will not work)
------	----------------	---

MPn.DWH MPWM Duty WH Register

PWM W channel duty register is a 16-bit register.

MP0.DWH=0x4000_4018, MP1.DWH=0x4000_5018

15	14	13	12	11	10	9	8	7	6	5	4	3	2	1	0
DUTY WH															
0x0001															
R/W															

15:0	DUTY WH	16-bit PWM Duty for WH output. It should be larger than 0x0001 (if Duty is 0x0000, PWM will not work)
------	----------------	---

MPn.DUL MPWM Duty UL Register

PWM U channel duty register is a 16-bit register.

MP0.DUL=0x4000_401C, MP1.DUL=0x4000_501C

15	14	13	12	11	10	9	8	7	6	5	4	3	2	1	0
DUTY UL															
0x0001															
R/W															

15:0	DUTY UL	16-bit PWM Duty for UL output. It should be larger than 0x0001 (if Duty is 0x0000, PWM will not work)
------	----------------	---

MPn.DVL MPWM Duty VL Register

PWM V channel duty register is a 16-bit register.

MP0.DVL=0x4000_4020, MP1.DVL=0x4000_5020

15	14	13	12	11	10	9	8	7	6	5	4	3	2	1	0
DUTY VL															
0x0001															
R/W															

15:0	DUTY VL	16-bit PWM Duty for VL output. It should be larger than 0x0001 (if Duty is 0x0000, PWM will not work)
------	----------------	---

MPn.DWL MPWM Duty WL Register

PWM W channel duty register is a 16-bit register.

MP0.DWL=0x4000_4024, MP1.DWL=0x4000_5024

15	14	13	12	11	10	9	8	7	6	5	4	3	2	1	0
DUTY WL															
0x0001															
R/W															

15:0	DUTY WL	16-bit PWM Duty for WL output. It should be larger than 0x0001 (if Duty is 0x0000, PWM will not work)
------	----------------	---

MPn.IER MPWM Interrupt Enable Register

PWM Interrupt Enable Register is an 8-bit register.

MP0.IER=0x4000_4034, MP1.IER=0x4000_5034,

7	6	5	4	3	2	1	0
PRDIEN	BOTIEN	WHIE	VHIE	UHIE	WLIE	VLIE	ULIE
0	0	0	0	0	0	0	0
RW	RW	RW	RW	RW	RW	RW	RW

7	PRDIEN	PWM Counter Period Interrupt enable 0 interrupt disable 1 interrupt enable
6	BOTIEN	PWM Counter Bottom Interrupt enable 0 interrupt disable 1 interrupt enable
5	WHIE ATR6IE	WH Duty or ATR6 Match Interrupt enable 0 interrupt disable 1 interrupt enable
4	VHIE ATR5IE	VH Duty or ATR5 Match Interrupt enable 0 interrupt disable 1 interrupt enable
3	UHIE ATR4IE	UH Duty or ATR4 Match Interrupt enable 0 interrupt disable 1 interrupt enable
2	WLIE ATR3IE	WL Duty or ATR3 Match Interrupt enable 0 interrupt disable 1 interrupt enable
1	VLIE ATR2IE	VL Duty or ATR2 Match Interrupt enable 0 interrupt disable 1 interrupt enable
0	ULIE ATR1IE	UL Duty or ATR1 Match Interrupt enable 0 interrupt disable 1 interrupt enable

MPn.IER[5:0] control bits are shared by the duty match interrupt event and ADC trigger match interrupt event. When ADC trigger mode is disabled, the interrupt is generated by the duty match condition; else the interrupt is generated by the ADC trigger counter match condition. The ADC trigger mode is selected by the ATMOD bit field in the ATRm register.

MPn.SR MPWM Status Register

PWM Status Register is a 16-bit register.

MP0.SR=0x4000_4030, MP1.SR=0x4000_5030

15	14	13	12	11	10	9	8	7	6	5	4	3	2	1	0
DOWN	IRQCNT							PRDIF	BOTIF	DWHIF ATR6F	DVHIF ATR5F	DUHIF ATR4F	DWLIF ATR3F	DVLIF ATR2F	DULIF ATR1F
0	000			0	0	0	0	0	0	0	0	0	0	0	0
R/W	R/W							R/W	R/W	R/W	R/W	R/W	R/W	R/W	R/W

15	DOWN	0	PWM Count Up
		1	PWM Count Down
14	IRQCNT[2:0]	Interrupt count number of period match (Interval PRDIRQ mode)	
12			
7	PRDIF	PWM Period Interrupt flag(write "1" to clear flag)	
		0	No interrupt occurred
		1	Interrupt occurred
6	BOTIF	PWM Bottom Interrupt flag(write "1" to clear flag)	
		0	No interrupt occurred
		1	Interrupt occurred
5	DWHIF ATR6F	PWM duty WH interrupt flag(write "1" to clear flag) (Duty interrupt is enabled if ATR6 was disabled)	
		0	No interrupt occurred
		1	Interrupt occurred
4	DVHIF ATR5F	PWM duty VH interrupt flag(write "1" to clear flag) (Duty interrupt is enabled if ATR5 was disabled)	
		0	No interrupt occurred
		1	Interrupt occurred
3	DUHIF ATR4F	PWM duty UH interrupt flag(write "1" to clear flag) (Duty interrupt is enabled if ATR4 was disabled)	
		0	No interrupt occurred
		1	Interrupt occurred
2	DWLIF ATR3F	PWM duty WL interrupt flag(write "1" to clear flag) (Duty interrupt is enabled if ATR3 was disabled)	
		0	No interrupt occurred
		1	Interrupt occurred
1	DVLIF ATR2F	PWM duty VL interrupt flag(write "1" to clear flag) (Duty interrupt is enabled if ATR2 was disabled)	
		0	No interrupt occurred
		1	Interrupt occurred
0	DULIF ATR1F	PWM duty UL interrupt flag(write "1" to clear flag) (Duty interrupt is enabled if ATR1 was disabled)	
		0	No interrupt occurred
		1	Interrupt occurred

MPn.CNT MPWM Counter Register

PWM Counter Register is a 16-bit Read-Only register.

MP0.CNT=0x4000_4038, MP1.CNT=0x4000_5038															
15	14	13	12	11	10	9	8	7	6	5	4	3	2	1	0
MPnCNT															
0x0000															
R/W															

MPnCNT	PWM Counter Value
--------	-------------------

MPn.DTR MPWM Dead Time Register

PWM Dead Time Register is a 16-bit register.

MP0.DTR=0x4000_403C, MP1.DTR=0x4000_503C															
15	14	13	12	11	10	9	8	7	6	5	4	3	2	1	0
DTEN	PSHRT						DTCLK	DT							
0	0	0	0	0	0	0	0	0x00							
RW								RW							

DTEN	Dead-time function enable
	0 Disable Dead-time function
	1 Enable Dead-time function
PSHRT	Protect short condition
	0 Protection disable
	1 When H-side and L-side are active, disable both side
DTCLK	Dead-time prescaler
	0 Dead time counter uses PWM CLK/4
	1 Dead time counter uses PWM CLK/16
DT[7:0]	Dead Time value (Dead time setting makes output delay of 'low to high transition' in normal polarity)
	0x01 ~0xFF : Dead time

Note: Protect short condition is for only internal PWM level and not for external PWM level. When the internal signal of H-side and L-side are the same high level, the protection short function works to force both H-side and L-side to low level.

MPn.PCR0/1 MPWM Protection 0/1 Control Register

PWM Protection Control Register is a 16-bit register.

MP0.PCR=0x4000_4040, MP1.PCR=0x4000_5040

15	14	13	12	11	10	9	8	7	6	5	4	3	2	1	0
PROTEN	PROTPOL				PROTD			PROTIE		WHPROTM	VHPROTM	UHPROTM	WLPROTM	VPROTM	UPROTM
0	0				000			0		0	0	0	0	0	0
RW	RW				RW			RW		RW	RW	RW	RW	RW	RW

15	PROTOEN	Enable Protection Input 0
14	PROTOPOL	Select Protection Input Polarity 0: Low-Active 1: High-Active
10	PROTD	Protection Input debounce 8 0 – no debounce 1~7 – debounce by (MPWMCLK * PROTD[2:0])
7	PROTIE	Protection Interrupt enable 0 Disable protection interrupt 1 Enable protection interrupt
5	WHPROTM	Activate W-phase H-side protection output 0 Disable Protection Output 1 Enable Protection Output with FOR value
4	VHPROTM	Activate V-phase H-side protection output 0 Disable Protection Output 1 Enable Protection Output with FOR value
3	UHPROTM	Activate U-phase H-side protection output 0 Disable Protection Output 1 Enable Protection Output with FOR value
2	WLPROTM	Activate W-phase L-side protection output 0 Disable Protection Output 1 Enable Protection Output with FOR value
1	VLPROTM	Activate V-phase L-side protection output 0 Disable Protection Output 1 Enable Protection Output with FOR value
0	ULPROTM	Activate U-phase L-side protection output 0 Disable Protection Output 1 Enable Protection Output with FOR value

MPn.PSR0/1 MPWM Protection 0/1 Status Register

PWM Protection Status Register is a 16-bit register. This register indicates which outputs are disabled and users can set the output masks manually. Without writing PROTKEY when writing any value, the written values are ignored.

MP0.PSR=0x4000_4044, MP1.PSR=0x4000_5044

15	14	13	12	11	10	9	8	7	6	5	4	3	2	1	0
PROTKEY								PROTIF		WHPROT	VHPROT	UHPROT	WLPROT	VPROT	UPROT
-								0		0	0	0	0	0	0
WO								RC		RW	RW	RW	RW	RW	RW

15	PROTKEY	Protection Clear Access Key To clear flags, write 0xCA with protection flag (PSR0 key is 0xCA and PSR1 key is 0xAC) Writing without PROTKEY prohibited.
7	PROTIF	Protection Interrupt status 0 No Protection Interrupt 1 Protection Interrupt occurred
5	WHPROT	Activate W-phase H-side protection flag 0 Protection not occurred. 1 Protection occurred or protection output enabled
4	VHPROT	Activate V-phase H-side protection flag 0 Protection not occurred. 1 Protection occurred or protection output enabled
3	UHPROT	Activate U-phase H-side protection flag 0 Protection not occurred. 1 Protection occurred or protection output enabled
2	WLPROT	Activate W-phase L-side protection flag 0 Protection not occurred. 1 Protection occurred or protection output enabled
1	VLPROT	Activate V-phase L-side protection flag 0 Protection not occurred. 1 Protection occurred or protection output enabled
0	ULPROT	Activate U-phase L-side protection flag 0 Protection not occurred. 1 Protection occurred or protection output enabled

Note: MPn.PCR0 is related to the PRTINn pin and MPn.PCR1 is related to OVINn.

MPn.ATRm

MPWMn ADC Trigger Counter m Register

MPn.ATR1	MPWM ADC Trigger Counter 1 Register
MPn.ATR2	MPWM ADC Trigger Counter 2 Register
MPn.ATR3	MPWM ADC Trigger Counter 3 Register
MPn.ATR4	MPWM ADC Trigger Counter 4 Register
MPn.ATR5	MPWM ADC Trigger Counter 5 Register
MPn.ATR6	MPWM ADC Trigger Counter 6 Register

The PWM ADC Trigger Counter Register is a 32-bit register.

MP0.ATR1=0x4000_4058, MP1.ATR1=0x4000_5058
 MP0.ATR2=0x4000_405C, MP1.ATR2=0x4000_505C
 MP0.ATR3=0x4000_4060, MP1.ATR3=0x4000_5060
 MP0.ATR4=0x4000_4064, MP1.ATR4=0x4000_5064
 MP0.ATR5=0x4000_4068, MP1.ATR5=0x4000_5068
 MP0.ATR6=0x4000_406C, MP1.ATR6=0x4000_506C

31	30	29	28	27	26	25	24	23	22	21	20	19	18	17	16	15	14	13	12	11	10	9	8	7	6	5	4	3	2	1	0																
								ATUDT								ATMOD								ATCNT																							
																								0x0000																							
																RW								RW								RW															

19	ATUDT	Trigger register update mode
		0 ADC trigger value applied at period match event (at the same time with period and duty registers update)
		1 Trigger register update mode When this bit set, written Trigger register values are sent to trigger compare block after two PWM clocks (through synchronization logic)
17	ATMOD	ADC trigger Mode register
16		00 ADC trigger Disable
		01 Trigger out when up count match
		10 Trigger out when down count match
		00 Trigger out when up-down count match
15	ATCNT	ADC Trigger counter
0		(it should be less than PWM period)

Functional Description

The PWMx module allows users to configure the PWM for different types of modulation schemes described in the previous section. The PER2 and PCER2 registers must be configured to enable the PWMx peripheral and the PWMx peripheral clock.

Setting or resetting the MOTOR bit in the MPnMR register allows users to operate the motor in Independent or Complementary PWM modes. For more information about operating modes, refer to the diagrams in the following section.

Figure 16.3 shows the diagram for generating a PWM output signal.

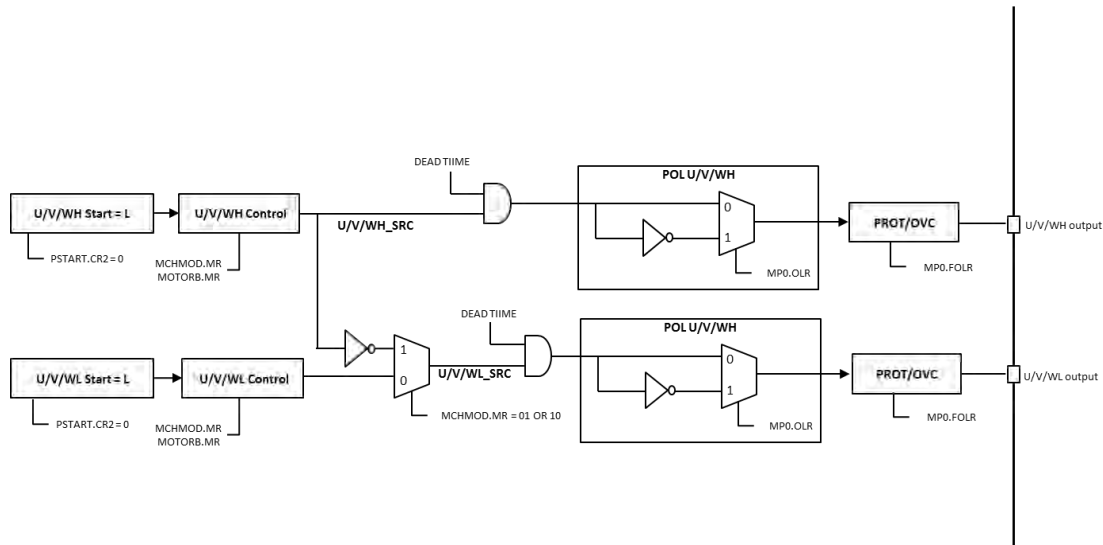

Figure 16.3 PWM Output Generation Chain

Normal PWM Up Count Mode Timing

In normal PWM mode, each channel runs independently. 6 PWM outputs can be generated. An example waveform is shown in Figure 16.4. Before PSTART is activated, the PWM output stay at the default value L. When PSTART is enabled, the period counter starts up count until the MP0.PRD count value. In the first period, the MPWM does not generate a PWM pulse.

The PWM pulse is generated from the second period. The active level is derived at the start of the counter value during duty value time.

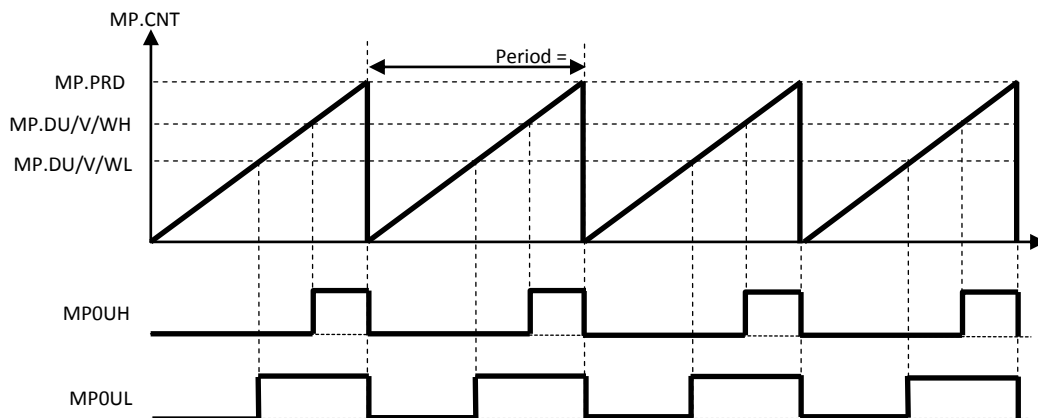

Figure 16.4. Up Count Mode Waveform (MOTORB=1, UPDOWN=0)

Normal PWM Up/Down Count Mode Timing

The basic operation of the Up/Down count mode is the same as the Up count mode except that one up/down period is twice as long as an UP count mode period. The default active level is opposite in a pair PWM output. This output polarity can be controlled by the MP0.OLR register.

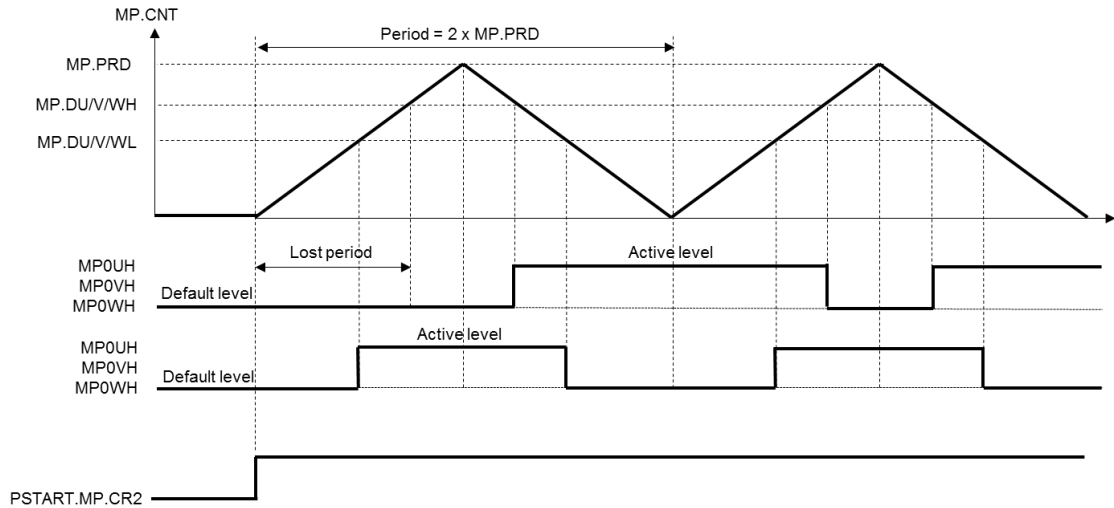

Figure 16.5. Up/Down Count Mode Waveform (MOTORB=0, MCHMOD=0, UPDOWN=1)

Motor PWM 2-Channel Symmetric Mode Timing

The motor PWM operation has three types of operating mode:

- 2-Channel symmetric mode
- 1-Channel symmetric mode
- 1-Channel asymmetric mode

Figure 16.6 shows a 2-channel symmetric mode waveform.

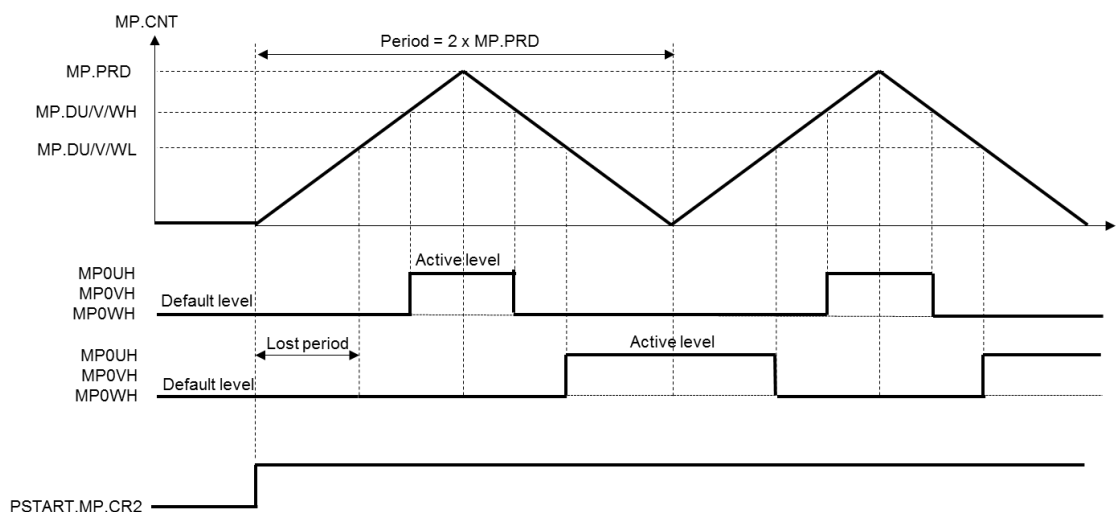

Figure 16.6. 2-Channel Symmetric Mode Wave Form (MOTORB=0, MCHMOD=00)

The default start level of both H-side and L-side is low. For the H-side, the PWM output level is changed to active level when the duty level is matched in the up count period and is returned to the default level when the duty level is matched in the down count period.

The symmetrical feature appears in each channel which is controlled by the corresponding DUTY register value.

Motor PWM 1-Channel Asymmetric Mode Timing

The 1 channel asymmetric mode generates asymmetric duration pulses which are defined by the H-side and L-side DUTY register. Therefore, the L-side signal is always the negative signal of H-side. During the up count period, the H-side DUTY register matching condition generates the active level pulse and during the down count period, the L-side DUTY register matching condition generates the default level pulse.

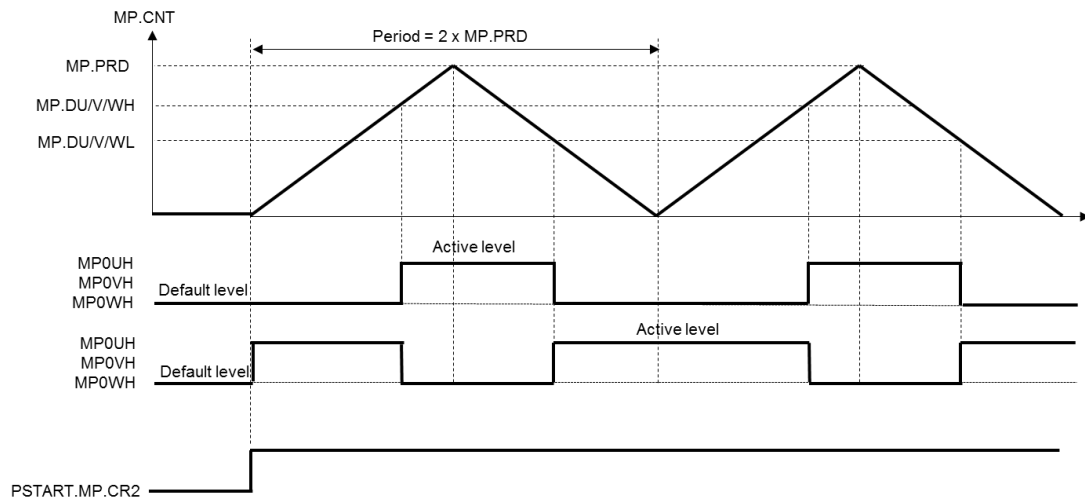

Figure 16.7. 1-Channel Asymmetric Mode Waveform (MOTORB=0,MCHMOD=01)

The default start level of both H-side and L-side is low. For the H-side, PWM output level is changed to active level when the H-side duty level is matched in up count period and is returned to default level when the L-side duty level is matched in down count period.

When the PSTART is set, the L-side PWM output is changed to the active level then the L-side PWM output is inverse output of H-side output.

Motor PWM 1-Channel Symmetric Mode Timing

The 1-channel symmetric mode generates a symmetric duration pulse which is defined by the H-side DUTY register. Therefore, the L-side signal is always the negative of the H-side signal. During up count period, the H-side DUTY register matching condition creates the active level pulse and during down count period, the H-side DUTY register matching condition also generates the default level pulse.

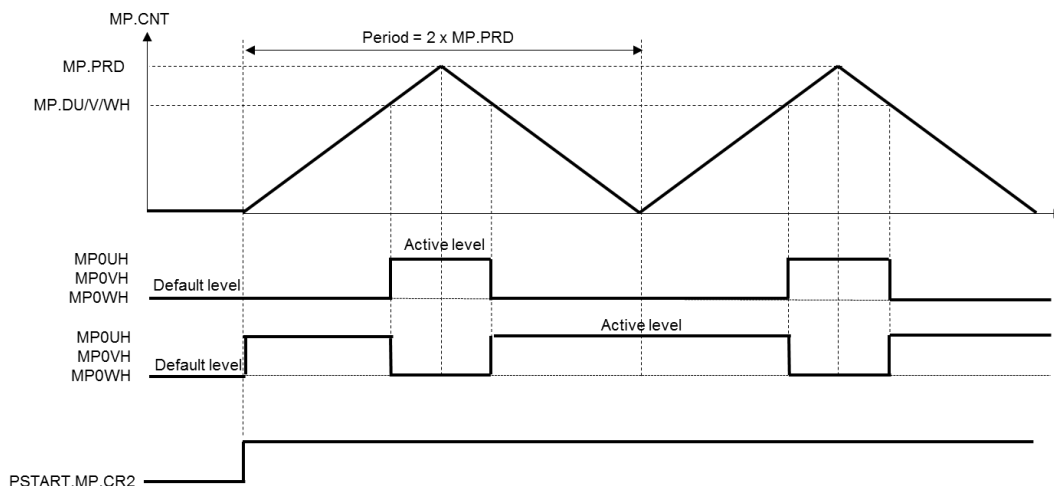

Figure 16.8. 1-Channel Symmetric Mode Waveform (MOTORB=0,MCHMOD=10)

The default start level of both H-side and L-side is low. For the H-side, PWM output level is changed to active level when the H-side duty level is matched in up count period and is returned to the default level when the H-side duty level is matched again in down count period.

When PSTART is set, the L-side PWM output is changed to the active level, then the L-side PWM output is inverse output of H-side output.

PWM Dead-time Operation

To prevent external short conditions, the MPWM provides dead time functionality. This function is only available for motor PWM mode. When one of H-side or L-side output changes to active level, the amount of dead time is inserted if the DTEN.MP.DTR bit is enabled.

The duration of dead time is decided by the value in the DT.MP.DTR[7:0] field.

When DTCLK = 0, the dead time duration = DT[7:0] * (PWM clock period * 4)

When DTCLK = 1, the dead time duration = DT[7:0] * (PWM clock period * 16)

When the PWM counter reaches the duty value, the PWM output is masked and the dead time counter starts to run. When the dead time counter reaches the value in the DT[7:0] register, the output mask is disabled.

Figure 16.9 is an example of dead time operation in 1-channel symmetric mode.

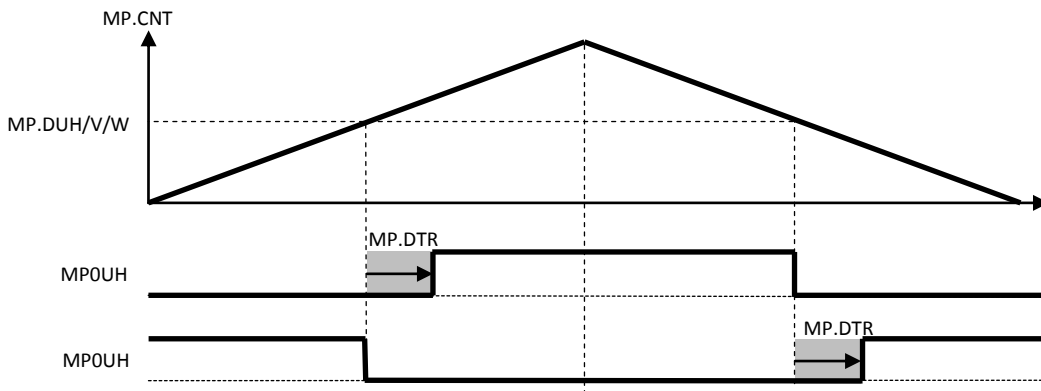

Figure 16.9. PWM Dead-time Operation Timing Diagram (Symmetric Mode)

Figure 16.10 is an example of dead time operation in 1-channel asymmetric mode

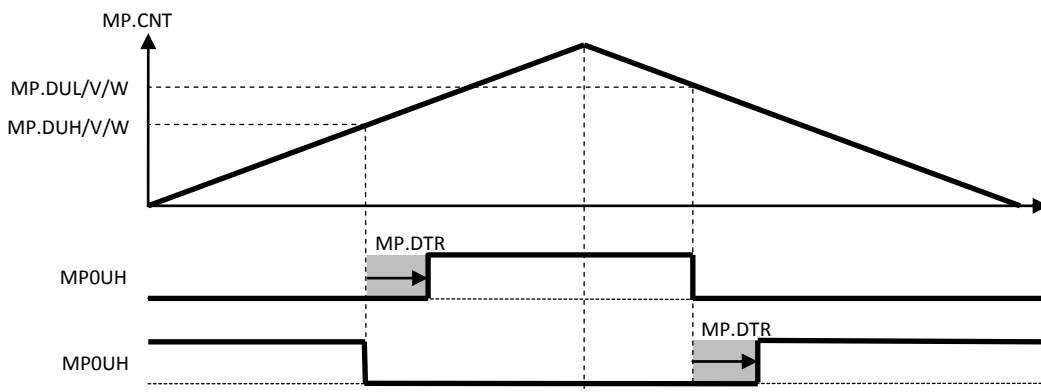

Figure 16.10. PWM Dead-time Operation Timing Diagram (Asymmetric Mode)

The dead time function is not available for 2-channel symmetric mode. Therefore, the dead condition is generated by each channel's duty control.

MPWM Dead-time Timing Examples

The following images show how the dead-time operates. In normal situations, the dead time masking is activated at duty match time and the dead time counter runs. When the dead time counter reaches the dead time value, the mask is disabled.

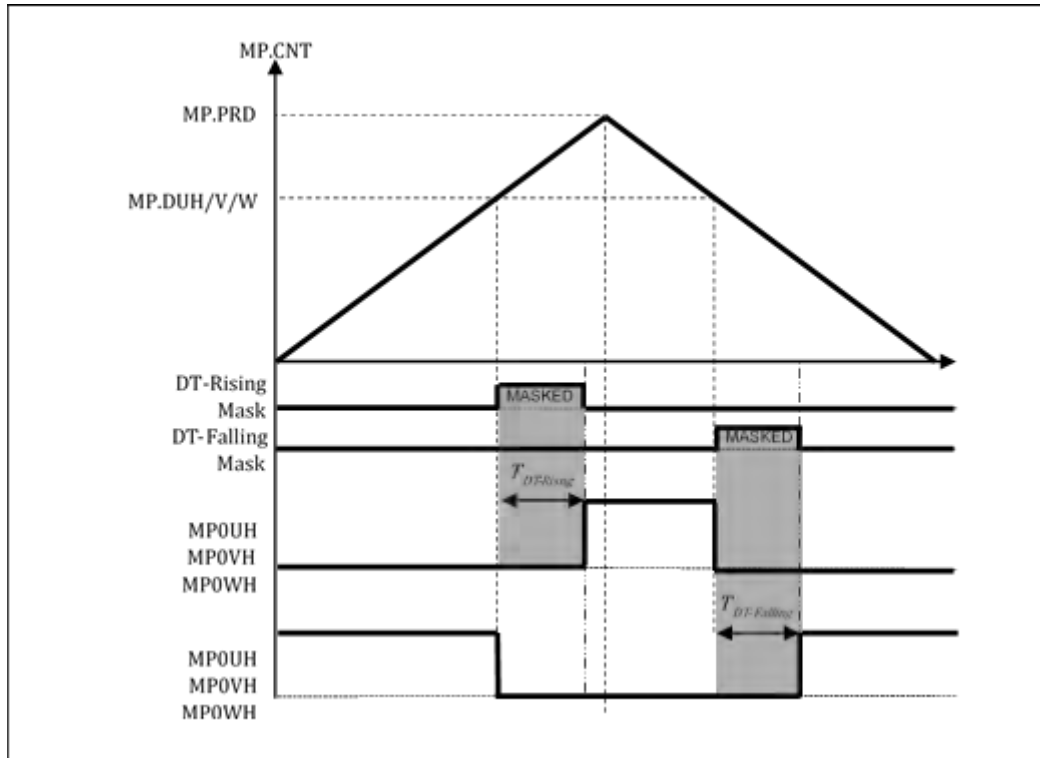

Figure 16.11. Normal Dead-time Operation ($T_{DUTY} > T_{DT}$)

The following figures show the dead time configuration in special situations.

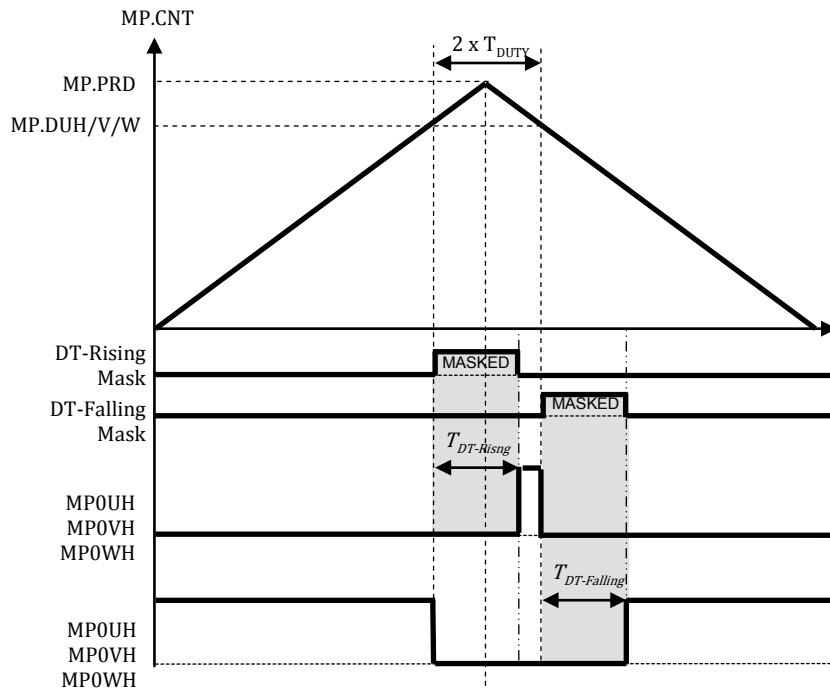

Figure 16.12. Minimum H-side Pulse Timing ($T_{DUTY} < T_{DT} < 2 \times T_{DUTY}$)

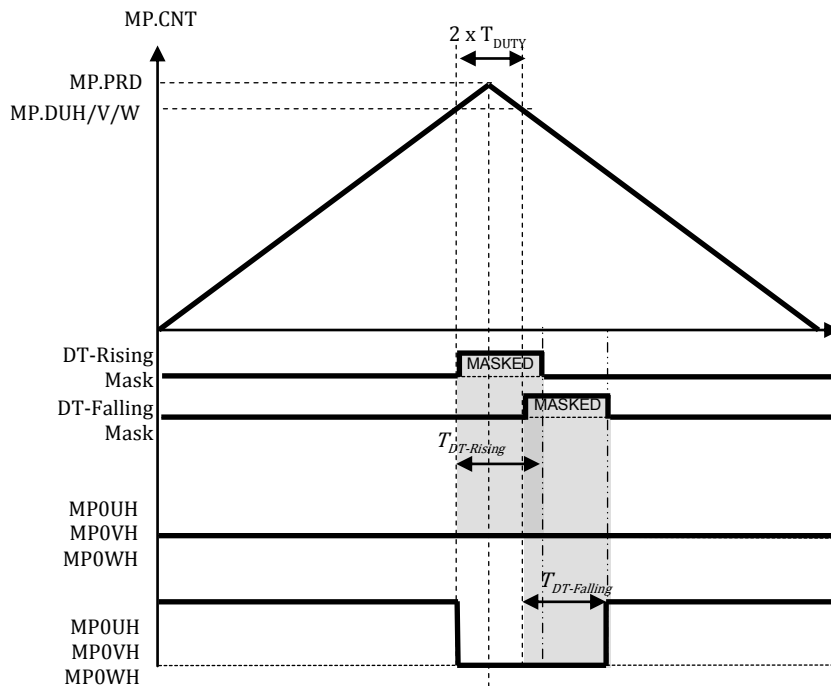

Figure 16.13. Zero H-side Pulse Timing ($T_{DT} > 2 \times T_{DUTY}$)

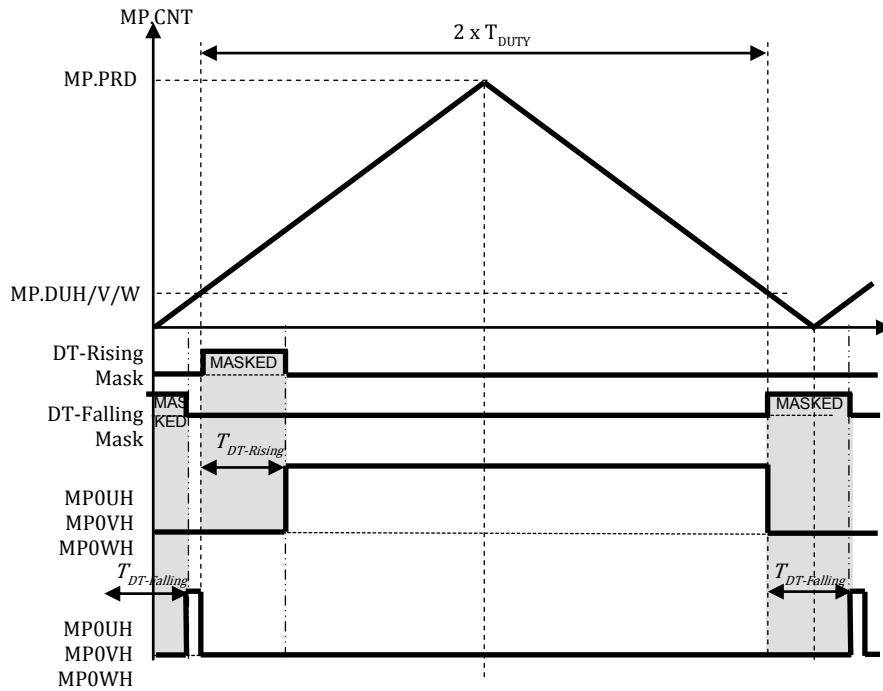

Figure 16.14. Minimum L-side Pulse Timing ($T_{DT} < \text{Period} - T_{DUTY}$)

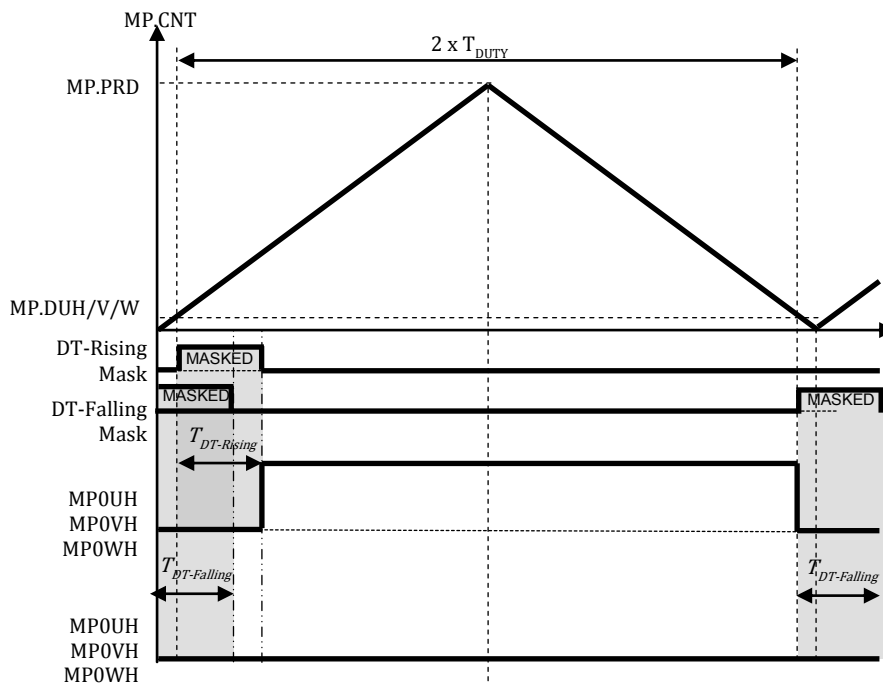

Figure 16.15. Zero L-side Pulse Timing ($T_{DT} > \text{Period} - T_{DUTY}$)

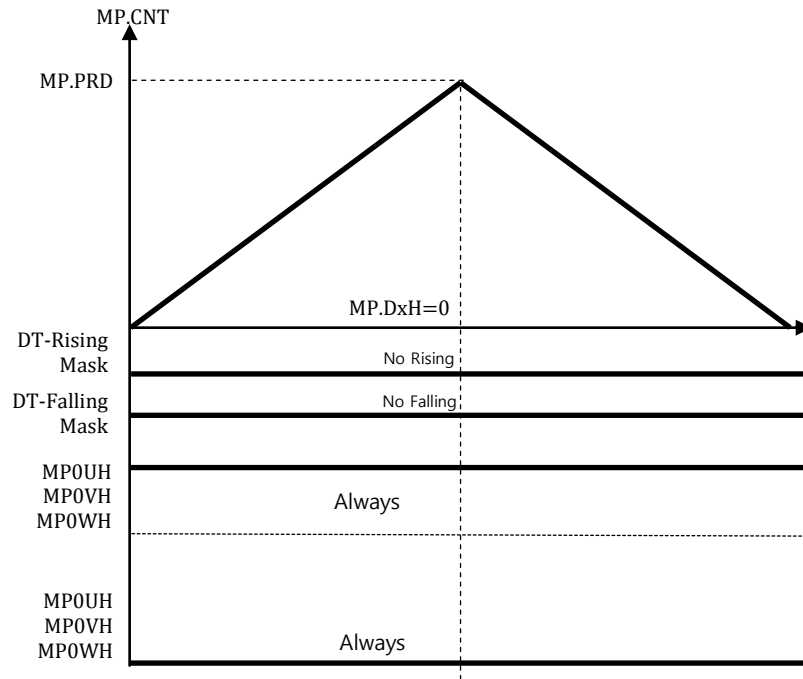

Figure 16.16. H-side Always On ($T_{DUTY} = \text{Period}$: Dead-time Disabled)

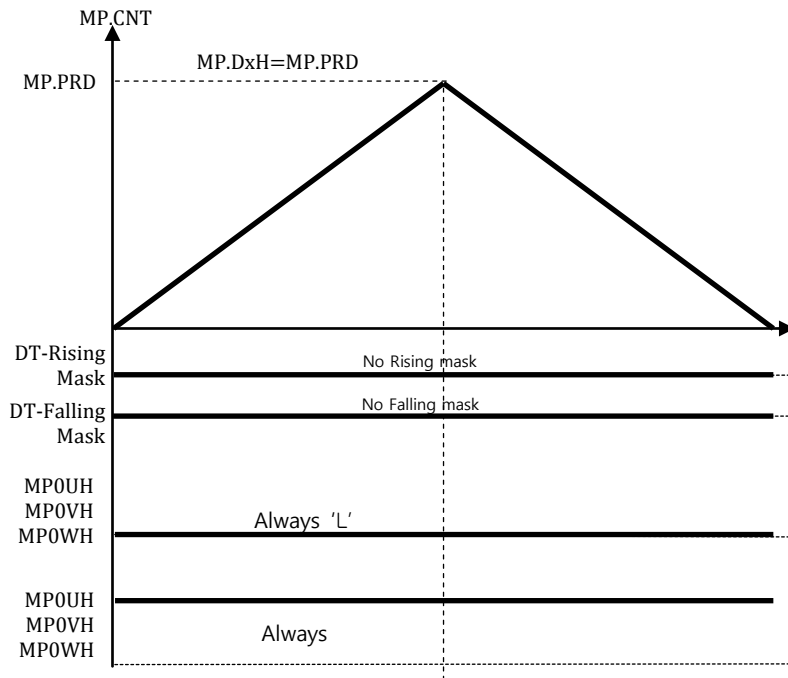

Figure 16.17. L-side Always On ($T_{DUTY} = '0'$: Dead-time Disabled)

Symmetrical Mode vs Asymmetrical Mode

In symmetrical mode, the wave form is symmetrical on both sides of the mid-point of the period. The duty comparison is performed twice in both up and down count periods.

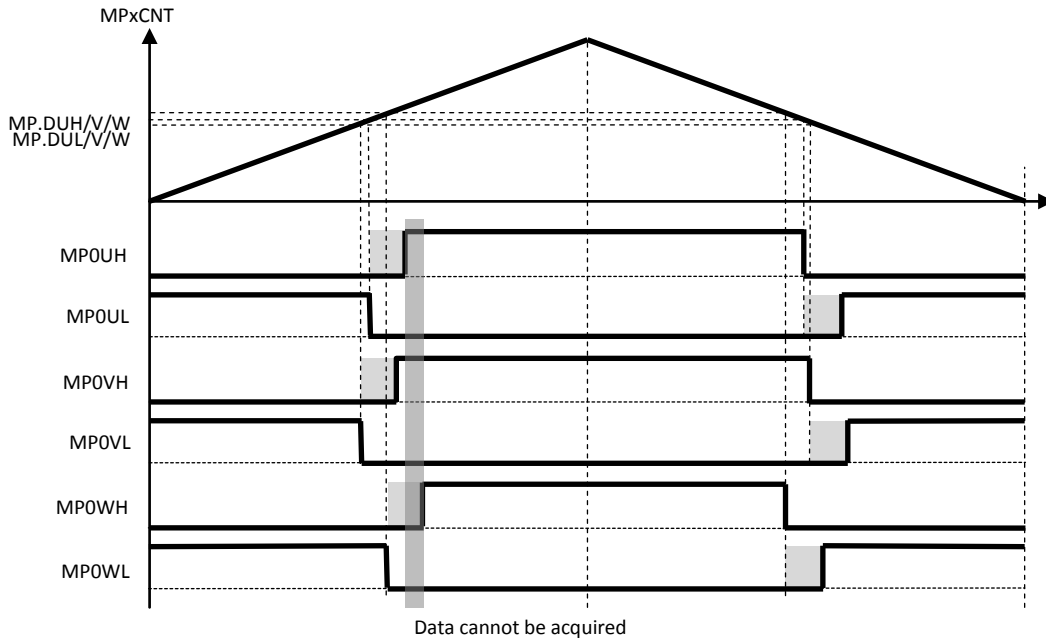

Figure 16.18. Symmetrical PWM Timing

In asymmetrical mode, the wave form is not symmetrical from the mid-point of the period. The duty comparison of H-side is performed in up count period. The duty comparison of L-side is performed in down count period.

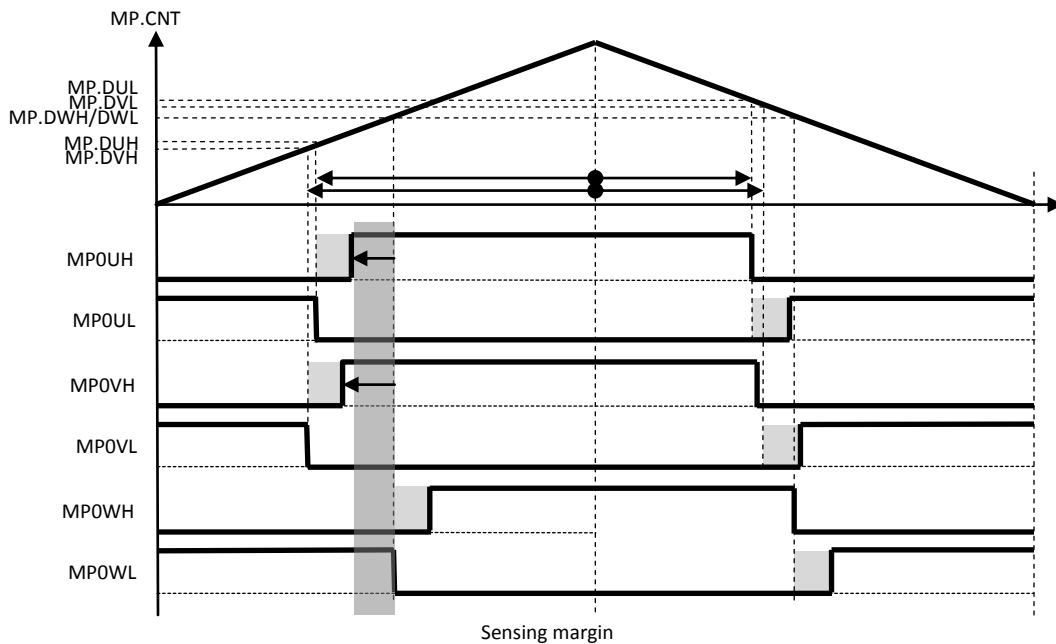

Figure 16.19. Asymmetrical PWM Timing and Sensing Margin

Description of ADC Triggering Function

A total of 6 ADC trigger timing registers are provided. This dedicated register generates a trigger signal to start ADC conversion. The conversion channel of ADC is defined in the ADC control register.

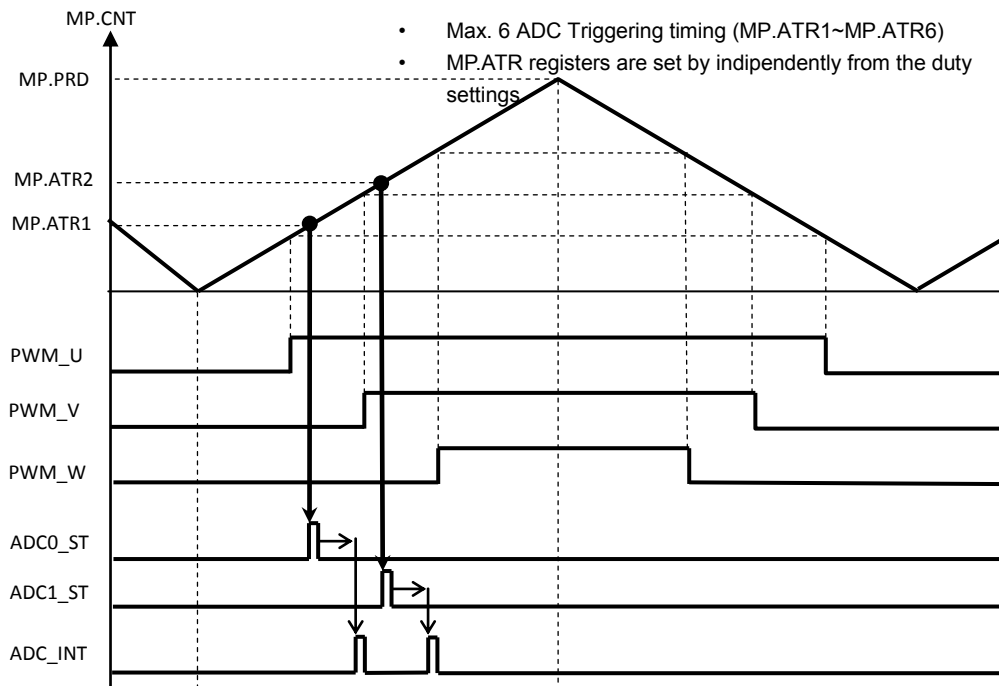

Figure 16.20. ADC Triggering Function Timing Diagram

An example of ADC data acquisition is shown in Figure 16.21.

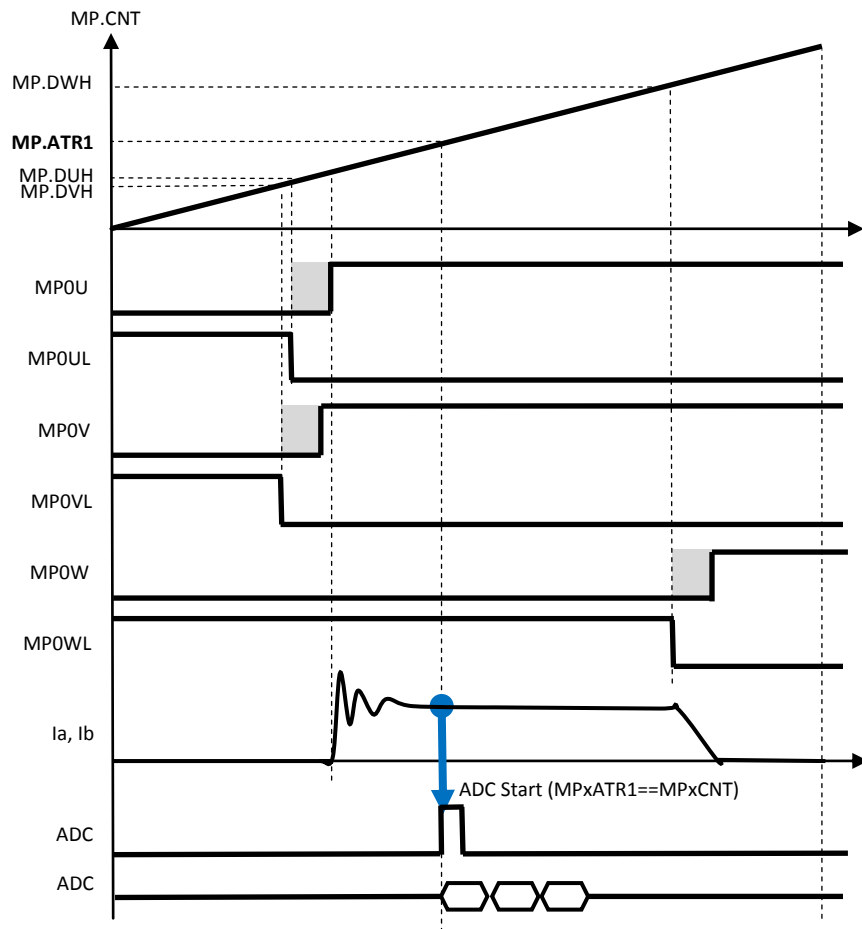

Figure 16.21. An Example of ADC Acquisition Timing by Event from MPWM

Interrupt Generation Timing

Each timing event can make interrupt requests to the CPU.

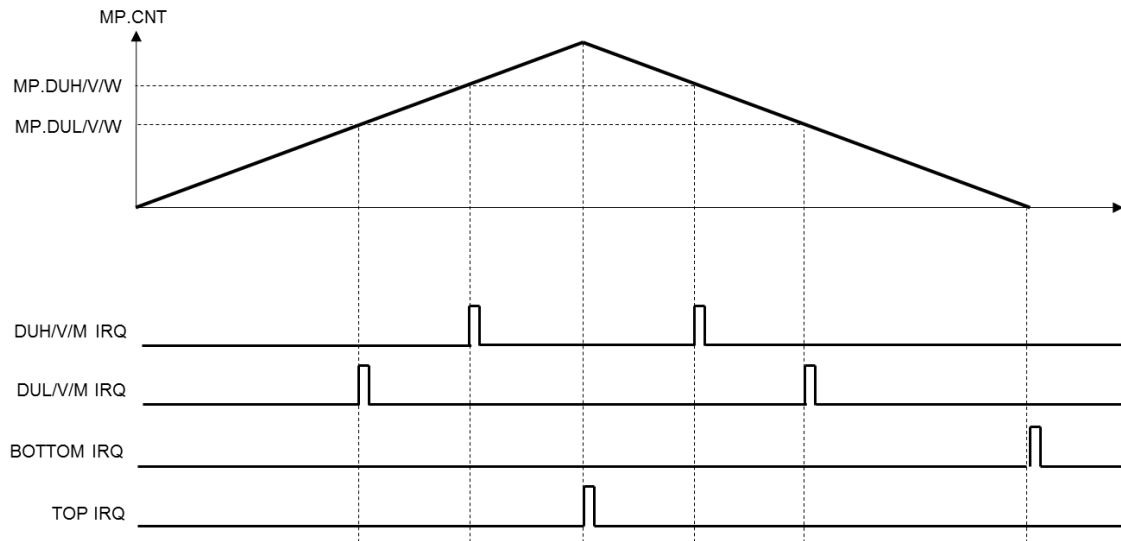

Figure 16.22. Interrupt Generation Timing

17. 12-Bit A/D Converter

Introduction

ADC block consists of 2 independent ADC units.

- 16 Channels of analog inputs
- Single and Sequential conversion mode
- Up to 8 times sequential conversion support
- External pin trigger support
- 8 internal trigger sources support (PWMs, timers)
- Adjustable sample & hold time

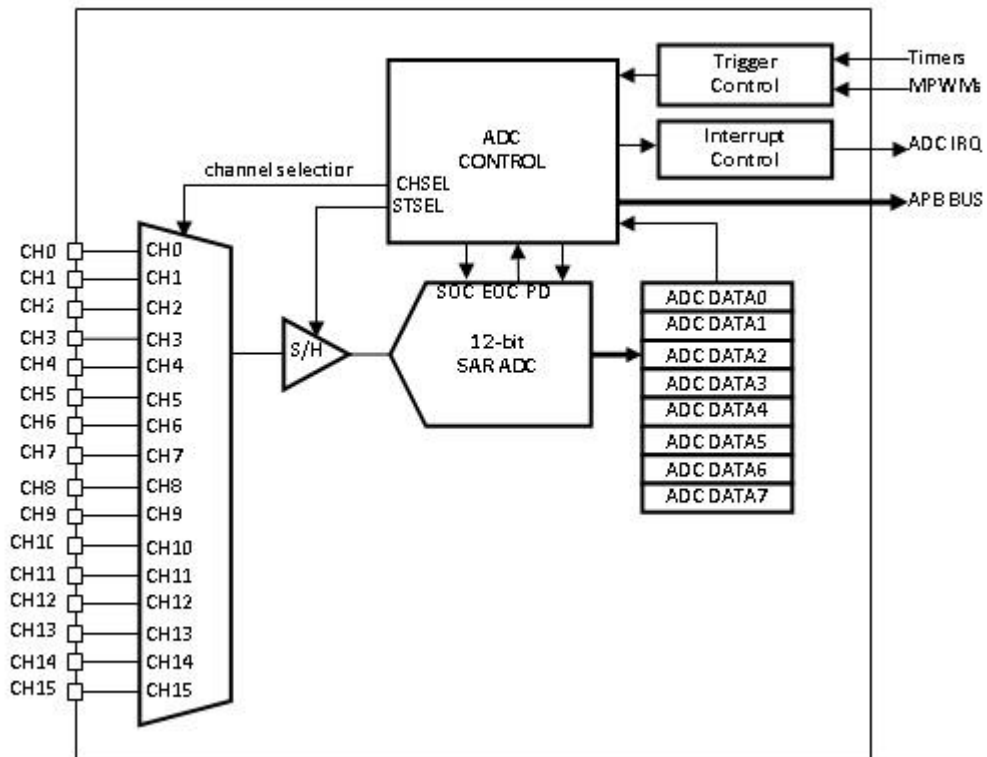

Figure 17.1. Block Diagram

Pin Description

Table 17.1. External Signal

PIN NAME	TYPE	DESCRIPTION	AINx PIN to ADC Channel Mapping	
			ADC0	ADC1
AVDD	P	Analog Power(3.0V~VDD)	ADC0	ADC1
AVSS	P	Analog GND		
AN0	A	ADC Input 0	Channel 0	Channel 0
AN1	A	ADC Input 1	Channel 1	Channel 1
AN2	A	ADC Input 2	Channel 2	Channel 2
AN3	A	ADC Input 3	Channel 3	Channel 3
AN4	A	ADC Input 4	Channel 4	Channel 4
AN5	A	ADC Input 5	Channel 5	Channel 5
AN6	A	ADC Input 6	Channel 6	--
AN7	A	ADC Input 7	Channel 7	--
AN8	A	ADC Input 8	Channel 8	--
AN9	A	ADC Input 9	Channel 9	--
AN10	A	ADC Input 10	Channel 10	--
AN11	A	ADC Input 11	Channel 11	--
AN12	A	ADC Input 12	Channel 12	--
AN13	A	ADC Input 13	Channel 13	--
AN14	A	ADC Input 14	Channel 14	Channel 6
AN15	A	ADC Input 15	--	Channel 7
AN16	A	ADC Input 16	--	Channel 8
AN17	A	ADC Input 17	--	Channel 9
AN18	A	ADC Input 18	--	Channel 10
AN19	A	ADC Input 19	--	Channel 11
AN20	A	ADC Input 20	--	Channel 12
AN21	A	ADC Input 21	--	Channel 13

Registers

The base addresses of ADC units are shown in Table 17.2.

Table 17.2. ADC Base Address

	BASE ADDRESS
ADC0	0x4000_B000
ADC1	0x4000_B100

Table 17.3 shows the register memory map.

Table 17.3. ADCIF Register Map

Name	Offset	R/W	Description	Reset
ADn.MR	0x0000	R/W	ADC Mode register	0x00
ADn.CSCR	0x0004	R/W	ADC Current Sequence/Channel register	0x00
ADn.CCR	0x0008	R/W	ADC Clock Control register	0x80
ADn.TRG	0x000C	R/W	ADC Trigger Selection register	0x00
-	0x0010	-	Reserved	
-	0x0014	-	Reserved	
ADn.SCSR	0x0018	R/W	ADC Burst mode channel select	0x00
ADn.CR	0x0020	R/W	ADC Control register	0x00
ADn.SR	0x0024	R/W	ADC Status register	0x00
ADn.IER	0x0028	R/W	ADC Interrupt Enable register	0x00
ADn.DDR	0x002C	R	ADCn DMA Data Register	0x00
ADn.DR0	0x0030	R	ADCn Sequence 0 Data register	0x00
ADn.DR1	0x0034	R	ADCn Sequence 1 Data register	0x00
ADn.DR2	0x0038	R	ADCn Sequence 2 Data register	0x00
ADn.DR3	0x003C	R	ADCn Sequence 3 Data register	0x00
ADn.DR4	0x0040	R	ADCn Sequence 4 Data register	0x00
ADn.DR5	0x0044	R	ADCn Sequence 5 Data register	0x00
ADn.DR6	0x0048	R	ADCn Sequence 6 Data register	0x00
ADn.DR7	0x004C	R	ADCn Sequence 7 Data register	0x00

ADn.MR ADCn Mode Register

ADC Mode Registers are 32-bit registers. This register configures ADC operation mode. This register should be written first before the other registers.

AD0.MR=0x4000_B000, AD1.MR=0x4000_B100

31	30	29	28	27	26	25	24	23	22	21	20	19	18	17	16	15	14	13	12	11	10	9	8	7	6	5	4	3	2	1	0
													DMACH	DMAEN							SEQCNT			ADEN	ARST	ADMOD					TRGSEL
													0x0	0x0							0x0			0x0	0x0	0x0					0x0
													RW	RW							RW			RW	RW	RW					RW

18	DMACH	DMA channel option When DMACH is set, Channel information of DMA data will be located at ADDMAR[3:0] for half word size transfer. Channel information is at ADDMAR[19:16] in default.(DMACH is low)																
17	DMAEN	DMA enable bit – should be set to ‘1’ when ADCEN=‘1’. When DMA function is enabled, DMA request at every end of conversion (also in burst mode) and interrupt request only be generated when ADC receives DMA done from DMAC.																
16 12	STSEL	Sampling Time Selection ADC Sample & Hold circuit sampling time become (2 + STSEL[4:0]) MCLK cycles Minimum sampling time is 2 MCLK cycle When STSEL[4:0]=11111, the sampling channel is always on.																
10 8	SEQCNT	Number of conversions in a sequence If ADMOD is 2’h0 and SEQCNT is not 3’h0, CSEQN will be increased up to SEQCNT by trigger event.																
		<table border="1"> <tr> <td>000</td> <td>Single mode</td> <td>100</td> <td>5 sequence AD conversion</td> </tr> <tr> <td>001</td> <td>2 sequence AD conversion</td> <td>101</td> <td>6 sequence AD conversion</td> </tr> <tr> <td>010</td> <td>3 sequence AD conversion</td> <td>110</td> <td>7 sequence AD conversion</td> </tr> <tr> <td>011</td> <td>4 sequence AD conversion</td> <td>111</td> <td>8 sequence AD conversion</td> </tr> </table>	000	Single mode	100	5 sequence AD conversion	001	2 sequence AD conversion	101	6 sequence AD conversion	010	3 sequence AD conversion	110	7 sequence AD conversion	011	4 sequence AD conversion	111	8 sequence AD conversion
000	Single mode	100	5 sequence AD conversion															
001	2 sequence AD conversion	101	6 sequence AD conversion															
010	3 sequence AD conversion	110	7 sequence AD conversion															
011	4 sequence AD conversion	111	8 sequence AD conversion															
7	ADEN	0 ADC disable 1 ADC enable																
6	ARST	0 Stop at the end of sequence. Should set ASTART as 1 to restart again 1 Restart at the end of sequence.																
5 4	ADMOD	00 Single/Continuous conversion mode 01 Sequenced conversion mode 10 Reserved 11 Reserved																
1 0	TRGSEL	00 Event Trigger Disabled/Soft-Trigger Only 01 Timer Event Trigger 10 MPWM0 Event Trigger 11 MPWM1 Event Trigger																

If ADn.MR.ADCMOD was set as Single Sequential Conversion mode (Single sequential mode), the AD channels are controlled by ADn.SCSR.SEQ0CH ~ SEQ7CH. Single sequential mode always starts from SEQ0CH when not writing CSEQN. If in single sequential mode and SEQCNT is set as 3, AD converts the channels which are assigned at ADn.SCSR.SEQ0CH, ADn.SCSR.SEQ1CH, and ADn.SCSR.SEQ2CH to ADn.TRG.SEQTRG0, ADn.TRG.SEQTRG1, and ADn.TRG.SEQTRG2 when ADn.MR.TRGSEL is 0x1(Timer Event Trigger) or 0x2(MPWM Event Trigger).

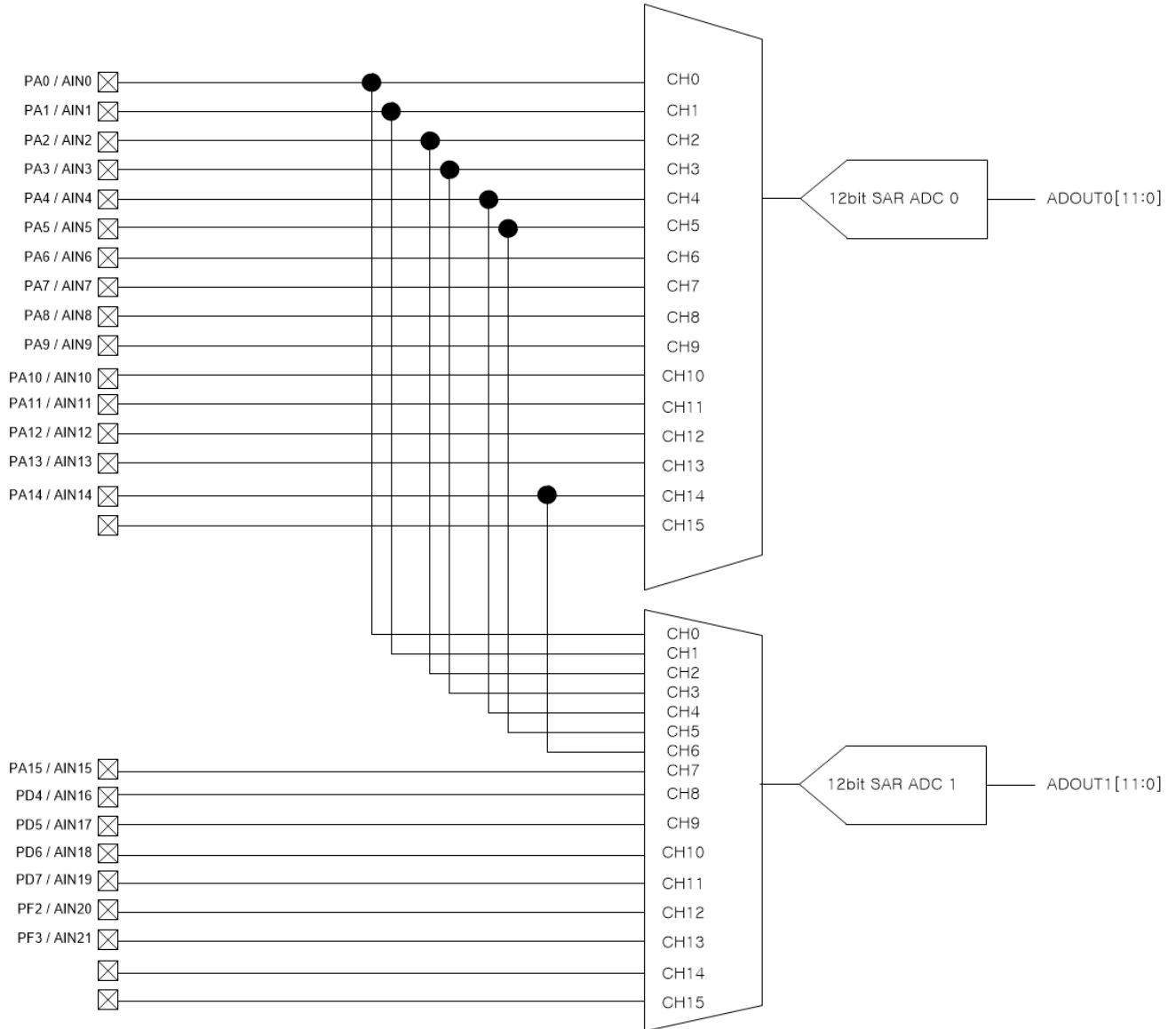

Figure 17.2. Analog Channel Block Diagram

ADn.CSCR ADCn Current Sequence/Channel Register

ADC Current Sequence/Channel Registers are 7-bit registers. These registers consist of Current Sequence Number and Current Active Channel value. CSEQN (Current Sequence Number) can be written to change the next sequence number. Upon writing CSEQN as 0x7 when CSEQN is 0x3 and ADn.MR.SEQCNT is 0x7, the next sequence number is 0x7 and AD converts this channel of ADn.SCSR.SEQ7CH. The 4,5,6 sequence is skipped. This register should be written first before ADn.SCSR.

D0.CSCR=0x4000_B004, AD1.CSCR=0x4000_B104

7	6	5	4	3	2	1	0
-	CSEQN			CACH			
-	0x0			0x0			
-	RW			RO			

7	CSEQN	Current Sequence Number , can write when not busy	
4		0000	Current Sequence is 0
		0001	Current Sequence is 1
		0010	Current Sequence is 2
		0011	Current Sequence is 3
		0100	Current Sequence is 4
		0101	Current Sequence is 5
		0110	Current Sequence is 6
		0111	Current Sequence is 7
3		CACH	Current Active Channel
R0	0000		ADC channel 0 is active
	0001		ADC channel 1 is active
	0010		ADC channel 2 is active
	0011		ADC channel 3 is active
	0100		ADC channel 4 is active
	0101		ADC channel 5 is active
	0110		ADC channel 6 is active
	0111		ADC channel 7 is active
	1000		ADC channel 8 is active
	1001		ADC channel 9 is active
	1010		ADC channel 10 is active
	1011		ADC channel 11 is active
	1100		ADC channel 12 is active
	1101		ADC channel 13 is active
	1110	ADC channel 14 is active	
1111	ADC channel 15 is active		

ADn.CR1 ADCn Clock Control Register

ADC Control Registers are 16-bit registers. ADC period register

AD0.CR1=0x4000_B008, AD1.CR1=0x4000_B108

15	14	13	12	11	10	9	8	7	6	5	4	3	2	1	0
ADCPDA	CKDIV							ADCPD	EXTCLK	CLKINVT	-	-	-	-	-
0	0x00							1	0	0					
RW	RW							RW	RW	RW					

15	ADCPDA	ADC R-DAC disable to save power Don't set "1" here(it's optional bit)
14 8	CLKDIV[6:0]	ADC clock divider when EXTCLK is '0'. ADC clock = system clock/CLKDIV CKDIV=0 : ADC clock=system clock CKDIV=1 : ADC clock=stop
7	ADCPD	ADC Power Down 0 - ADC normal mode 1 - ADC Power Down mode
6	EXTCLK	Select if ADC uses external clock. 0 - internal clock(CKDIV enabled) 1 - external clock(Clock configured in SCU_MCCR4)
5	CLKINVT	Divided clock inversion(optional bit) 0 - duty ratio of divided clock is larger than 50% 1 - duty ratio of divided clock is less than 50%

ADn.TRG ADC Trigger Selection Register

ADC Trigger registers are 32-bit registers. ADC Trigger channel register. In Single/Continuous mode, all the bit fields are used. In Burst conversion mode, only BSTTRG bit field(bit3~bit0) is used.

AD0.TRG=0x4000_B00C, AD1.TRG=0x4000_B10C

31	30	29	28	27	26	25	24	23	22	21	20	19	18	17	16	15	14	13	12	11	10	9	8	7	6	5	4	3	2	1	0
SEQTRG7				SEQTRG6				SEQTRG5				SEQTRG4				SEQTRG3				SEQTRG2				SEQTRG1				SEQTRG0 BSTTRG			
0x0				0x0				0x0				0x0				0x0				0x0				0x0							
RW				RW				RW				RW				RW				RW				RW							

30	SEQTRG7	8 th Sequence Trigger Source
28		
26	SEQTRG6	7 th Sequence Trigger Source
24		
22	SEQTRG5	6 th Sequence Trigger Source
20		
18	SEQTRG4	5 th Sequence Trigger Source
16		
14	SEQTRG3	4 th Sequence Trigger Source
12		
10	SEQTRG2	3 rd Sequence Trigger Source
8		
6	SEQTRG1	2 nd Sequence Trigger Source
4		
2	SEQTRG0	1 st Sequence Trigger Source
0		

Value	Timer (TRGSEL '2'h1)	MPWM0 (TRGSEL '2'h2)	MPWM1 (TRGSEL '2'h3)
0	Timer 0	MP0ATR1	MP1ATR1
1	Timer 1	MP0ATR2	MP1ATR2
2	Timer 2	MP0ATR3	MP1ATR3
3	Timer 3	MP0ATR4	MP1ATR4
4	Timer 8	MP0ATR5	MP1ATR5
5	Timer 9	MP0ATR6	MP1ATR6
6	-	BOTTOM	BOTTOM
7	-	PERIOD	PERIOD

ADn.SCSR ADC Sequence Channel Selection Register

The ADC Sequence Channel Select Register is a 32-bit register.

AD0.BCSR=0x4000_B018, AD1.BCSR=0x4000_B118

31	30	29	28	27	26	25	24	23	22	21	20	19	18	17	16	15	14	13	12	11	10	9	8	7	6	5	4	3	2	1	0
SEQ7CH				SEQ6CH				SEQ5CH				SEQ4CH				SEQ3CH				SEQ2CH				SEQ1CH				SEQ0CH			
0x0				0x0				0x0				0x0				0x0				0x0				0x0							
RW				RW				RW				RW				RW				RW				RW							

31	28	SEQ7CH	8 th conversion sequence channel selection
27	24	SEQ6CH	7 th conversion sequence channel selection
23	20	SEQ5CH	6 th conversion sequence channel selection
19	16	SEQ4CH	5 th conversion sequence channel selection
15	12	SEQ3CH	4 th conversion sequence channel selection
11	8	SEQ2CH	3 rd conversion sequence channel selection
7	4	SEQ1CH	2 nd conversion sequence channel selection
3	0	SEQ0CH	1 st conversion sequence channel selection

ADn.CR ADCn Control Register

This is the ADC start register. This register is an 8-bit register.

AD0.CR=0x4000_B020, AD1.CR=0x4000_B120

7	6	5	4	3	2	1	0
ASTOP							ASTART
0							0
W							RW

7	ASTOP	0	No
		1	ADC conversion stop (will be clear next @ADC clock) If ASTOP set after conversion cycle start, present conversion would be completed.
0	ASTART	0	No ADC conversion
		1	ADC conversion start (will be clear next @ADC clock) ADCEN should be "1" to start ADC. If ASTART is set as 0 when ARST is 0 in Timer/MPWM trigger event mode, AD converts to ADn.MR.SEQCNT once and AD stops. ASTART should be written to start the conversion sequence again

ADn.SR ADCn Status Register

The ADC Status Register is a 32-bit register.

AD0.SR=0x4000_B024, AD1.SR=0x4000_B124

7	6	5	4	3	2	1	0
EOC	ABUSY	DOVRUN	DMAIRQ	TRGIRQ	EOSIRQ	-	EOCIRQ
0	0	0	0	0	0	-	0
RO	RO	RO	RO	RC	RC	-	RC

7	EOC	ADC End-of-Conversion flag (Start-of-Conversion made by ADC_CLK clears this bit , not ASTART)
6	ABUSY	ADC conversion busy flag
5	DOVRUN	DMA overrun flag (not interrupt) (DMA ACK didn't come until end of next conversion)
4	DMAIRQ	DMA done received (DMA transfer is completed)
3	TRGIRQ	ADC Trigger interrupt flag(Write "1" to clear flag) (0: no int / 1: int occurred)
2	EOSIRQ	This flag will be set upon final end of a sequence (Write "1" to clear flag) 0 None. 1 End-of-Sequence(burst) Interrupt occurred
0	EOCIRQ	This flag will be set upon each conversion in a sequence is occurred(Write "1" to clear flag) 0 None. 1 End-of-Conversion Interrupt occurred

ADn.IER Interrupt Enable Register

AD0.IER=0x4000_B028, AD1.IER=0x4000_B128

7	6	5	4	3	2	1	0
			DMAIRQE	TRGIRQE	EOSIRQE	-	EOCIRQE
			0	0	0	-	0
			RW	RW	RW	-	RW

4	DMAIRQE	DMA done interrupt enable 0: interrupt disable 1: interrupt enable
3	TRGIRQE	ADC trigger conversion interrupt enable
2	EOSIRQE	ADC sequence conversion interrupt enable
0	EOCIRQE	ADC single conversion interrupt enable

ADn.DDR ADCn DMA Data Register

ADC DMA Data Registers are 16-bit registers. This is the ADC conversion result register for DMA (AD data of just completed conversion).

AD0.DDR=0x4000B02C, AD1.DDR=0x4000B12C

15	14	13	12	11	10	9	8	7	6	5	4	3	2	1	0
ADC DMA Temporary Data												ADMACH			
0x000												0x0			
R												R			

15	ADDMAR	ADC conversion result data (12-bit)
4		
3	ADMACH	ADC data channel indicator
0		

ADn.DRx ADCn Sequence Data Register 0~7

The DRx Data Registers are 16-bit registers. This is the ADC conversion result register for the related sequence number.

AD0.DR0=0x4000_B030, AD0.DR1=0x4000_B034, AD0.DR2=0x4000_B038, AD0.DR3=0x4000_B03C
 AD0.DR4=0x4000_B040, AD0.DR5=0x4000_B044, AD0.DR6=0x4000_B048, AD0.DR7=0x4000_B04C
 AD1.DR0=0x4000_B130, AD1.DR1=0x4000_B134, AD1.DR2=0x4000_B138, AD1.DR3=0x4000_B13C
 AD1.DR4=0x4000_B140, AD1.DR5=0x4000_B144, AD1.DR6=0x4000_B148, AD1.DR7=0x4000_B14C

15	14	13	12	11	10	9	8	7	6	5	4	3	2	1	0
ADCDATA															
0x000															
R															

15	ADCDATA	ADC Sequence Data (12-bit)
4		

Functional Description

The ADC block provides the ability to convert an analog signal to a digital value. The ADC compares the input channel with the AVDD voltage and provides a 12-bit value.

Voltage value = (ADC Reading / 4096) * AVDD voltage

The ADC clock can be configured up to 22.5Mhz and be driven from any of the available clocks – System clock, Ring OSC, Bus Clock, Int OSC, External OSC or the PLL clock. There is a 6 bit divider available for the system clock (divider must be greater than 1) or the ADC clock can be configured in the MCCR6 register, which provides access to all clocks and 8 bit divider. The clock is selected in CR1 register (and optionally configured in the SCU MCCR4 register).

The ADC takes 15 ADC clocks to complete one sample. There is a single clock to start then sample and hold time (minimum of 2 ADC clocks) then 1 clock per bit (12 bits). To increase sample time, you can configure up to 511 clock sampling time (which would then take 511 + 15 = 526 ADC clocks per sample).

To calculate the maximum ADC clock that can be used is:

ADC Clock = 1.5Msps * (15 clocks per sample + Sample time)

Example (Sampling time = 0):

ADC clock = 1.5Msps * (15 clocks + 0) = 22.5Mhz

The above example shows that if the system clock was running at 72 MHz the divider cannot be less than 4.

The sequence feature allows the programmer to retrieve multiple readings (up to 8) with only one start request. You can either continue to run the sequence or run it just once. The ADC block will automatically go through all 8 taking readings without intervention. Each sequence can be triggered on different events in order and sequence result has its own data register.

General ADC Setup Procedure

1. Allow the modification of the I/O pins to use the ADC inputs needed by writing the unlock sequence as described in PORT CONTROL UNIT (PCU), no pullups enabled.
2. Enable the ADC peripherals needed in PER2 register.
3. Enable the ADC peripheral clock in the PCER2 register.
4. Select the alternating function for the ADC inputs (Port n MUX registers).
5. Configure the ADC Pins to Analog
6. Configure the ADC mode in the ADCnMODE register and enabled the channel ADCn.
7. Configure the ADCnCR1 register and write an appropriate clock divider value.
8. Configure any special features such as triggers, sequencing, etc.
9. Start ADC conversion

ADC Single Mode Timing Diagram

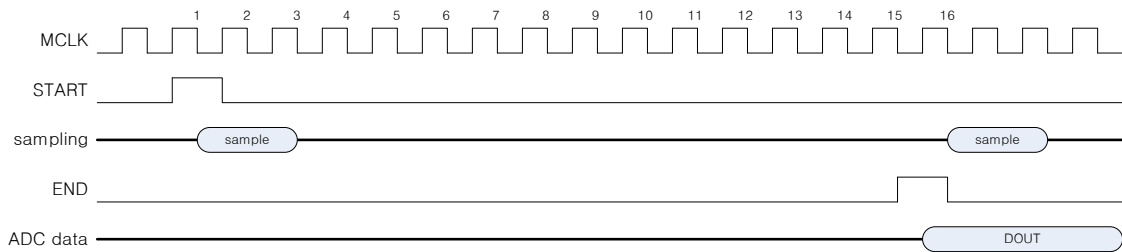

ADC Sequencing Mode Timing Diagram

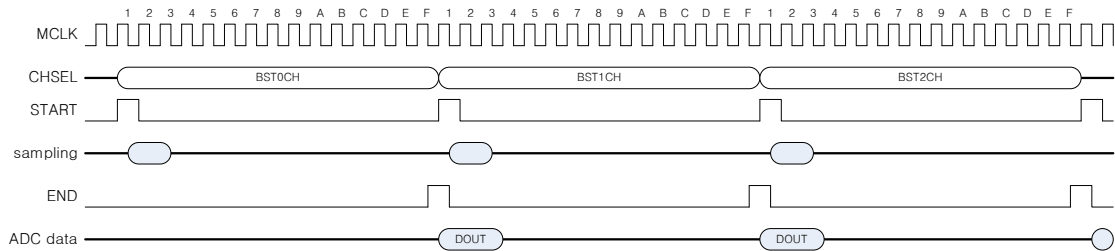

18. Electrical Characteristics

DC Characteristics

Absolute Maximum Ratings

Absolute maximum ratings are limiting values of operating and environmental conditions which should not be exceeded under the worst possible conditions..

Table 18.1. Absolute Maximum Rating

Parameter	Symbol	min	max	unit
Power Supply (VDD)	VDD	-0.5	+6	V
Analog Power Supply (AVDD)	AVDD	-0.5	+6	V
VDC Output Voltage	VDD18			V
Input High Voltage		-	VDD+0.5	V
Input Low Voltage		VSS – 0.5	-	V
Output Low Current per pin	I _{OL}		20	mA
Output Low Current Total	∑ I _{OL}			mA
Output Low Current per pin	I _{OH}		10	mA
Output Low Current Total	∑ I _{OH}			mA
Power consumption				mW
Input Main Clock Range		0.4	8	MHz
Operating Frequency		-	72	MHz
Storage Temperature	T _{st}	-55	+125	°C
Operating Temperature	T _{op}	-40	+85	°C

DC Characteristics

Table 18.2 Recommended Operating Conditions

Parameter	Symbol	Condition	Min	Typ.	Max	unit
Supply Voltage	VDD		3.0		5.5	V
Supply Voltage	AVDD		3.0	5.0	5.5	V
Operating Frequency	FREQ	MOSC	4		16	MHz
		INTOSC		20		MHz
		PLL	4		75	MHz
Operating Temperature	Top	Top	-40		+85	°C

Table 18.3 DC Electrical Characteristics (VDD = +5V, Ta = 25 °C)

Parameter	Symbol	Condition	Min	Typ.	Max	unit
Input Low Voltage	V _{IL}	Schmitt input	-	-	0.2VDD	V
Input High Voltage	V _{IH}	Schmitt input	0.8VDD	-	-	V
Output Low Voltage	V _{OL}	I _{OL} = 10mA	-	-	VSS+1.0	V
Output High Voltage	V _{OH}	I _{OH} = -3mA	VDD-1.0	-	-	V
Output Low Current	I _{OL}		-	-	3	mA
Output High Current	I _{OH}		-1.2	-		mA
Input High Leakage	I _{IH}				4	uA
Input Low Leakage	I _{IL}		-4			
Pull-up Resister	R _{PU}	Rmax:VDD =3.0V Rmin:VDD =5V	30	-	70	kΩ

POR Electrical Characteristics

Table18.4 POR Electrical Characteristics (Temperature: -40 ~ +105°C)

Parameter	Symbol	Condition	Min	Typ.	Max	unit
Operating Voltage	VDD18		1.6	1.8	2.0	V
Operating Current	IDD _{PoR}	Typ. <6uA If always on	-	60	-	nA
POR Set Level	VR _{PoR}	VDD rising (slow)	1.3	1.4	1.55	V
POR Reset Level	VF _{PoR}	VDD falling (slow)	1.1	1.2	1.4	V

BOD Electrical Characteristics

Table18.5 BOD Electrical Characteristics (Temperature: -40 ~ +105°C)

Parameter	Symbol	Condition	Min	Typ.	Max	unit
Operating Voltage	VDD		1.7		5	V
Operating Current	IDD _{BOD}	Typ. <6uA when always on	-	1	-	mA
BOD Set Level 0	VBOD0	VDD falling (slow)	1.7	1.8	1.9	V
BOD Set Level 1	VBOD1	VDD falling (slow)	2.1	2.2	2.3	V
BOD Set Level 2	VBOD2	VDD falling (slow)	3.2	3.3	3.4	V
BOD Set Level 3	VBOD3	VDD falling (slow)	4.2	4.3	4.4	V

VDC Electrical Characteristics

Table 18.6 VDC Electrical Characteristics (Temperature: -40 ~ +105°C)

Parameter	Symbol	Condition	Min	Typ.	Max	unit
Operating Voltage	VDD _{VDC}		3.0	-	5.5	V
VDC Output Voltage	VOUT _{VDC}	@RUN	1.62	1.8	1.98	V
		@STOP	1.4	1.8	2.0	V
Regulation Current	I _{OUT}				100	mA
Drop-out Voltage	VDR _{OP} _{VDC}	VDD _{VDC} =3.0V I _{OUT} =100mA	-	-	200	mV
Current Consumption	ID _D _{NORM}	@RUN	-	100	150	uA
	ID _D _{STOP}	@STOP	-	1	2	uA

External OSC Characteristics

Table 18.7 External OSC Characteristics (Temperature: -40 ~ +105°C)

Parameter	Symbol	Condition	Min	Typ	Max	unit
Operating Voltage	VDD		3.0	-	5.5	V
ID _D		@4MHz/5V	-	240		uA
Frequency	OSC _F _{req}		4	8	10	MHz
Output Voltage	OSC _V _{OUT}		1.2	2.4	-	V
Load Capacitance	LOAD _{CAP}		5	22	35	pF

Sub External OSC Characteristics

Table 18.8 External OSC Characteristics (Temperature: -40 ~ +85°C)

Parameter	Symbol	Condition	Min	Typ	Max	unit
Operating Voltage	VDD			1.8		V
ID _D		@4MHz/5V	-	2.93		uA
Frequency	OSC _F _{req}			32.768		KHz
Output Voltage	OSC _V _{OUT}			1.8	-	V
Load Capacitance	LOAD _{CAP}					pF

Internal RC OSC Characteristics

Table 18.9 Internal RC OSC Characteristics (Temperature: -40 ~ +105°C)

Parameter	Symbol	Condition	Min	Typ	Max	unit
Operating Voltage	VDD		1.65	1.8	1.95	V
ID _D	I _{OSC}	@20MHz	-	240		uA
Frequency	IOSC _F _{req}			20		MHz

PLL Electrical Characteristics

Table 18.10 PLL Electrical Characteristics (Temperature: -40 ~ +105°C)

Parameter	Symbol	Condition	Min	Typ.	Max	unit
Operating Voltage	VDD _{PLL}		1.65	1.8	1.95	V
Output Frequency	F _{OUT}		4		80	MHz
Operating Current	I _{DDPLL}	@80MHz		1.3		mA
Duty	F _{OUTDUTY}		40	-	60	%
P-P Jitter	JITTER	@Lock			500	Ps
VCO	VCO		30		80	MHz
Input Frequency	F _{IN}		4		8	MHz
Locking time	LOCK				1	ms

ADC Electrical Characteristics

Table 18.11 ADC Electrical Characteristics (Temperature: -40 ~ +105°C)

Parameter	Symbol	Condition	Min	Typ.	Max	unit
Operating Voltage	AVDD		3.0	5	5.5	V
Reference Voltage	AVREF		3.0	5	5.5	V
Resolution				12		Bit
Operating Current	IDDA				2.8	mA
Analog Input Range			0		AVDD	V
Conversion Rate				-	1.5	MHz
Operating Frequency	ACLK				15	MHz
DC Accuracy	INL			±2.5		LSB
	DNL			±1.0		LSB
Offset Error				±1.5		LSB
Full Scale Error				±1.5		LSB
SNDR	SNDR			68		dB
THD				-70		dB

LQFP-100 Package Dimension

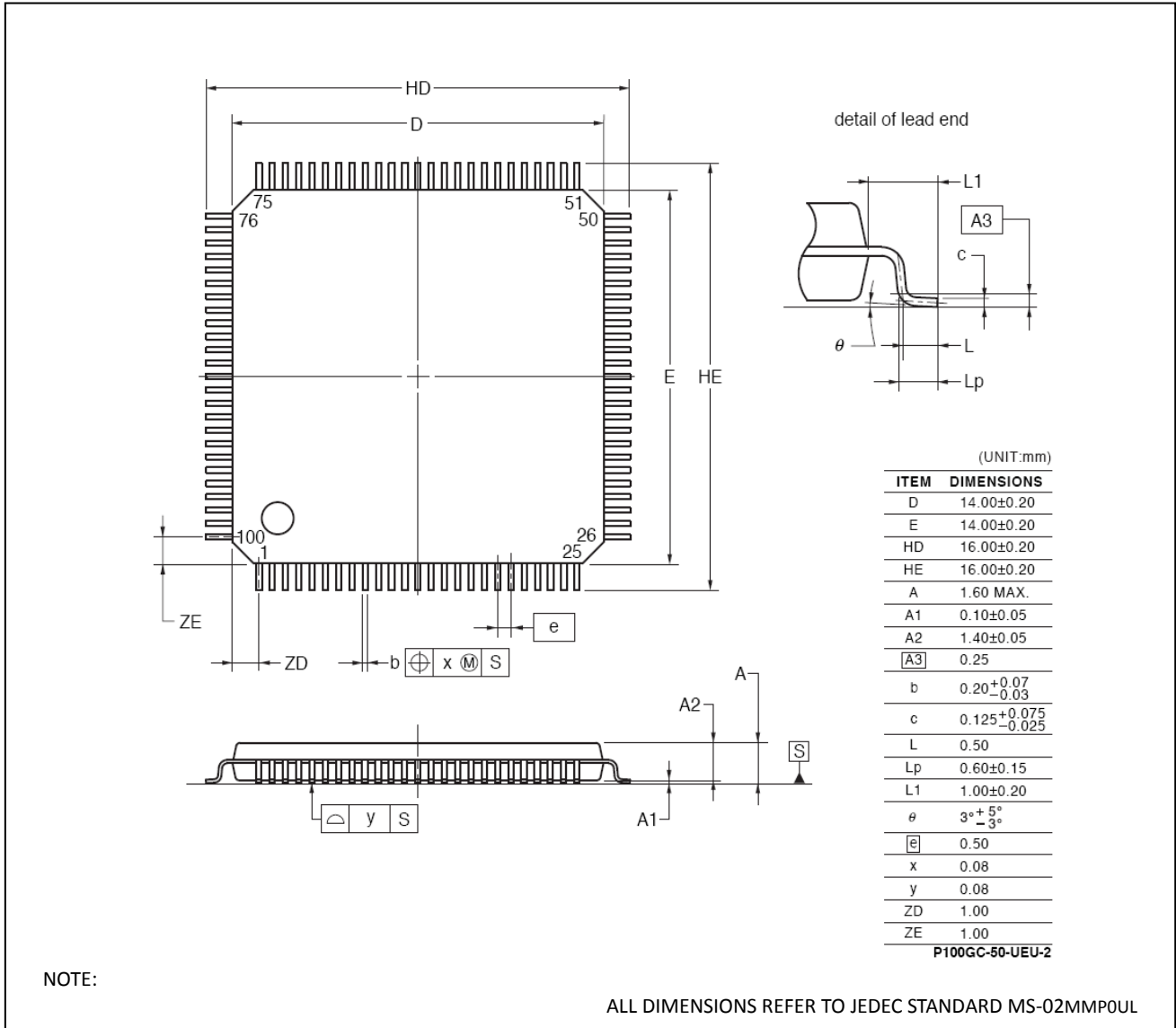

Figure 18.1. Package Dimension (LQFP-100 14X14)

Компания «Океан Электроники» предлагает заключение долгосрочных отношений при поставках импортных электронных компонентов на взаимовыгодных условиях!

Наши преимущества:

- Поставка оригинальных импортных электронных компонентов напрямую с производств Америки, Европы и Азии, а так же с крупнейших складов мира;
- Широкая линейка поставок активных и пассивных импортных электронных компонентов (более 30 млн. наименований);
- Поставка сложных, дефицитных, либо снятых с производства позиций;
- Оперативные сроки поставки под заказ (от 5 рабочих дней);
- Экспресс доставка в любую точку России;
- Помощь Конструкторского Отдела и консультации квалифицированных инженеров;
- Техническая поддержка проекта, помощь в подборе аналогов, поставка прототипов;
- Поставка электронных компонентов под контролем ВП;
- Система менеджмента качества сертифицирована по Международному стандарту ISO 9001;
- При необходимости вся продукция военного и аэрокосмического назначения проходит испытания и сертификацию в лаборатории (по согласованию с заказчиком);
- Поставка специализированных компонентов военного и аэрокосмического уровня качества (Xilinx, Altera, Analog Devices, Intersil, Interpoint, Microsemi, Actel, Aeroflex, Peregrine, VPT, Syfer, Eurofarad, Texas Instruments, MS Kennedy, Miteq, Cobham, E2V, MA-COM, Hittite, Mini-Circuits, General Dynamics и др.);

Компания «Океан Электроники» является официальным дистрибьютором и эксклюзивным представителем в России одного из крупнейших производителей разъемов военного и аэрокосмического назначения «JONHON», а так же официальным дистрибьютором и эксклюзивным представителем в России производителя высокотехнологичных и надежных решений для передачи СВЧ сигналов «FORSTAR».



JONHON

«JONHON» (основан в 1970 г.)

Разъемы специального, военного и аэрокосмического назначения:

(Применяются в военной, авиационной, аэрокосмической, морской, железнодорожной, горно- и нефтедобывающей отраслях промышленности)

«FORSTAR» (основан в 1998 г.)

ВЧ соединители, коаксиальные кабели,
кабельные сборки и микроволновые компоненты:

(Применяются в телекоммуникациях гражданского и специального назначения, в средствах связи, РЛС, а так же военной, авиационной и аэрокосмической отраслях промышленности).



Телефон: 8 (812) 309-75-97 (многоканальный)

Факс: 8 (812) 320-03-32

Электронная почта: ocean@oceanchips.ru

Web: <http://oceanchips.ru/>

Адрес: 198099, г. Санкт-Петербург, ул. Калинина, д. 2, корп. 4, лит. А