

# TRENCHSTOP™ 5 in TO-247 4pin Evaluation Board

EVAL-IGBT-650V-TO247-4  
EVAL-IGBT-650V-TO247-4-S

Authors: Dr. Vladimir Scarpa  
Klaus Sobe

Application Note

## About this document

### Scope and purpose

This document provides an operation guide to the TO-247 4pin Evaluation Board.

It provides detailed information about how to configure the board in each of its different operation modes. Additionally, it is also explained how to set up several measurements and parameters, like gate resistor and case temperature.

Finally, a description on how to conduct practical measurements with the board is given and how the user can reproduce them using its own board sample.

### Intended audience

TO-247 4pin Evaluation Board owners and any development Engineer interested on it.

## Table of Contents

<b>1</b>	<b>Introduction .....</b>	<b>1</b>
1.1	Scope and Purpose .....	2
<b>2</b>	<b>Board Overview.....</b>	<b>4</b>
<b>3</b>	<b>Eval Board Hardware and Configuration.....</b>	<b>7</b>
3.1	Package configuration: TO-247 and TO-247 4pin .....	7
3.2	Gate Driver Configuration .....	8
3.3	Heat sink temperature seting and monitoring .....	10
3.4	Test points .....	11
3.5	Current sensing .....	12
3.6	Configurable circuit topologies .....	13
<b>4</b>	<b>Measurements with the Eval board.....</b>	<b>15</b>
4.1	Measurement as a switching cell .....	15
4.2	Measurement using a coaxial shunt .....	15
4.3	Comparison between TO-247 4pin and standard TO-247 .....	17
4.4	Operation as a step-down DC-DC converter .....	18
<b>5</b>	<b>References .....</b>	<b>20</b>

## Warnings

**Attention:**  *The board described is an evaluation board dedicated for a laboratory environment ONLY! Because it operates at high voltages this board MUST only be operated by qualified and skilled personnel familiar with all applicable safety standards.*

**Attention:**  *For safe operation please read the whole document before handling the evaluation board! The board operates at high voltages and is deemed to be 'Dangerous equipment'!*

**Attention:**  *DO NOT TOUCH THE BOARD DURING OPERATION!*

**Attention:**  *Even brief accidental contact during operation might result in severe injury or death!*

**Attention:**  *Depending on the configuration of the board as well as the chosen supply-voltage, life-threatening voltages might be present!*

**Attention:**  *Always make sure that the capacitances are discharged before touching the board.*

**Attention:**  *Only qualified personnel are to be allowed to handle this board!*

## 1 Introduction

This evaluation (Eval) board, order name EVAL-IGBT-650V-TO247-4/S, has been developed to be a simple but accurate test bench. The board allows evaluating the performance advantages of the TRENCHSTOP™ 5 IGBTs in TO-247 4pin package. It can be easily configured to test IGBTs in standard TO-247 package. Before using the Eval board, it is highly recommended to read the application note *TRENCHSTOP™ 5 in TO-247 4pin Package* [1]

In the Eval board it possible to measure the IGBT losses during switching events. It has an optimized layout, which features an overall commutation loop inductance below 35 nH, including packages and sockets.

Different parameters can easily be set, like load current, DC-voltage, turn-on and turn-off gate resistors. Case temperature can be adjusted through a power resistor implemented onto the heat sink.

The Eval board can be used in continuous operation. From the basic phase-leg topology, it is possible to configure it as a step-down or step-up DC-DC converter.

Finally, this Eval board can serve as an example for PCB layout. Please note, however, that no standard has been followed regarding distances between components and tracks. They have been defined with the main scope of very low parasitic inductance on the power loop.

Chapter 2 of this document presents an overview on the Eval board and all its functionalities. Chapter 3 describes how to configure the hardware. Finally, Chapter 4 gives some practical examples of measurements. The Appendix contains the full board schematic, the bill of material and the PCB layers of the Eval board.

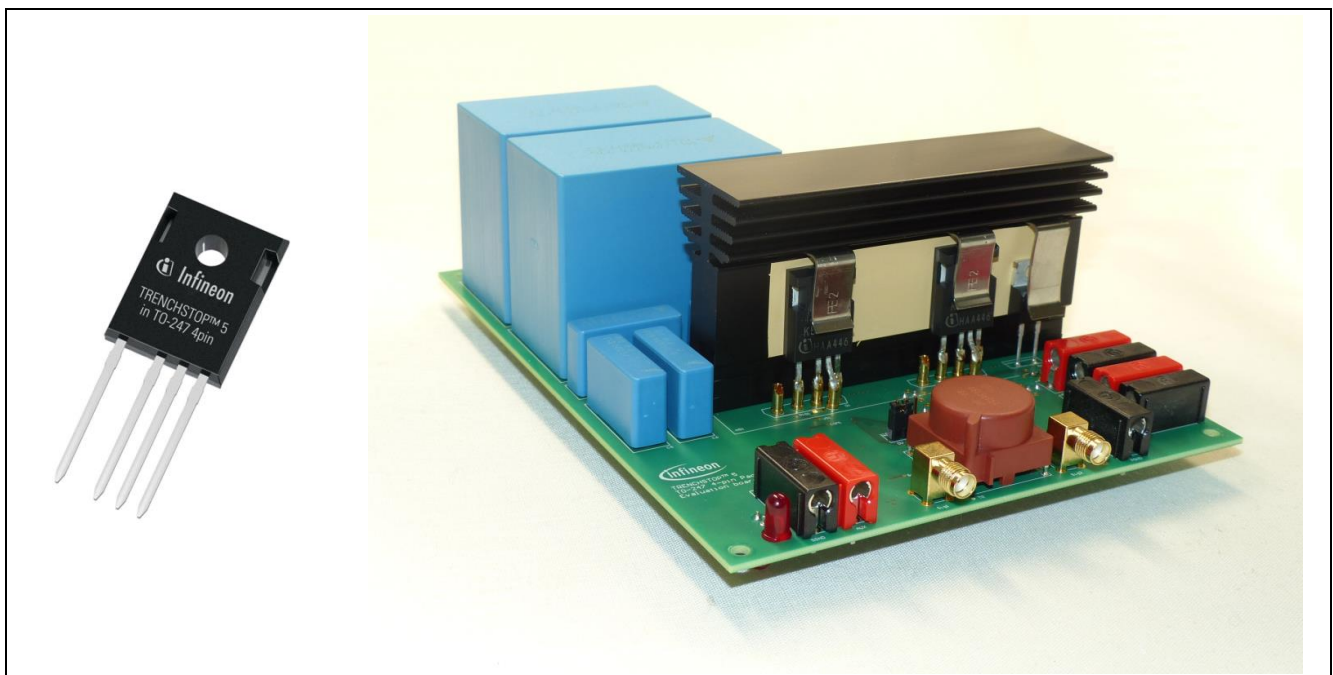

Figure 1 Discrete IGBT in TO-247 4pin package and the Eval board

## 2 Board Overview

The Eval board comes inside a case, as shown in Figure 2, containing:

- The Eval board
- Spare parts of IGBTs IKZ50N65EH5, IKZ50N65NH5 and IKW50N65H5, data sheets in [2]
- Spare parts of IC drivers 1EDI60I12AF, datasheets in [3]
- One adapter for oscilloscope probe
- One USB drive containing all related documents, including this application note
- 25 mΩ coaxial shunt, EVAL-IGBT-650V-TO247-4S only



Figure 2 Eval board case and components contained inside

Figure 3 depicts the general block diagram of the Eval board. It contains a phase-leg consisting of two IGBTs, S1 and S2, in either TO-247 or TO-247 4pin packages. Section 3.1 explains the required changes in the circuit to correctly accommodate each of the packages.

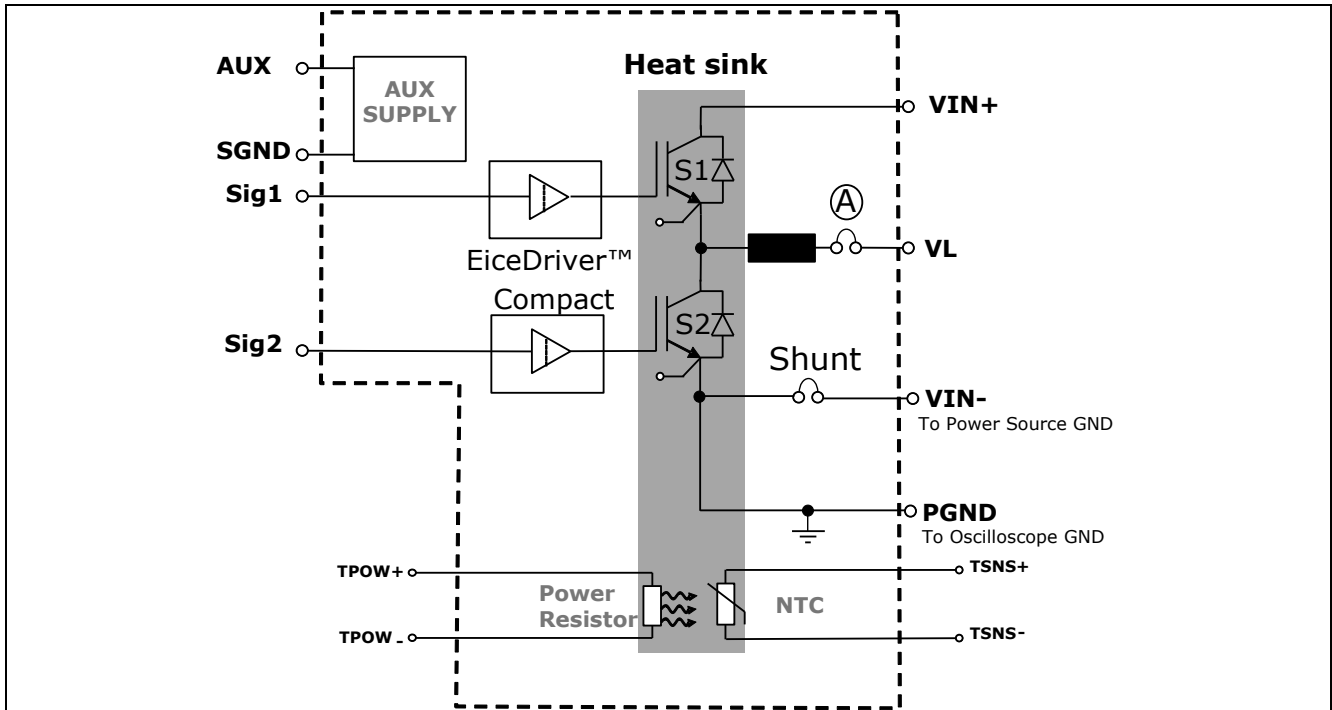

Figure 3 Block diagram of the TO-247 4pin Evaluation Board.

Each gate driver block is composed of one single channel 1EDI60I12AF device. The auxiliary (AUX) supply provides isolated voltages for the gate driver blocks. It has two connectors, **AUX** and **SGND**. The voltage between the terminals  $V_{AUX}$ , defines the driving voltage of the switches. Each of the IGBTs can be controlled independently, through two channels named **Sig 1** and **Sig 2**. These signals are referenced to **SGND**. A detailed description of the gate circuitry and how to set up the gate driver parameters is presented in section 3.2.

A top view to the Eval board is presented in Figure 4, marking the position of the board's connectors.

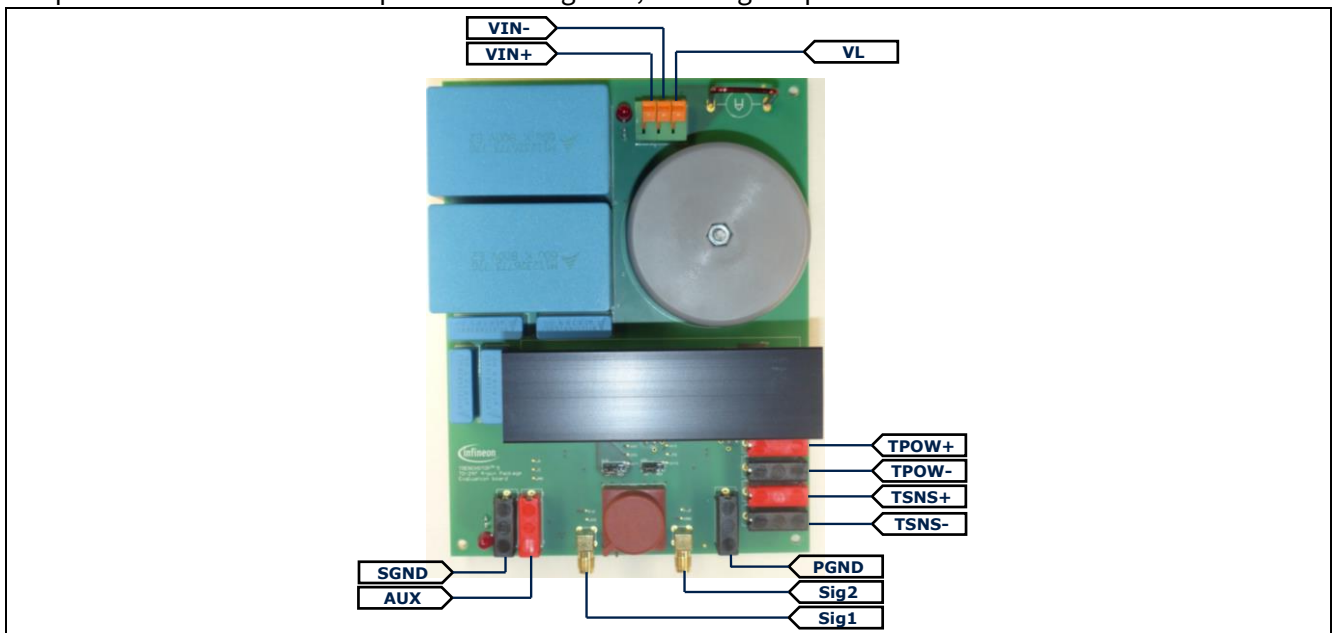

Figure 4 Top view of the Eval board with connectors' description

The heat sink can be heated up through an implemented power resistor. It is assembled onto the heat sink, on the opposite side of the two IGBTs. When power is applied to the terminals **TPOW+** and **TPOW-**, the temperature of the resistor will increase and the heat will spread over the entire heat sink surface. A temperature sensor (NTC) is also assembled onto the heat sink. Its resistance will vary according to the NTC's case temperature. The value can be read through the pins **TNS+** and **TNS-**. Section 3.3 provides more details on how to set the heat sink temperature and how to monitor it through the NTC sensor.

The bulk voltage is applied between terminals **VIN+** and **VIN-**. The terminal **VL** will be connected according to the test configuration desired. There is a connecting wire between the choke and **VL**. It can be used either for placing a current probe or, if the wire is removed, to insert an extra choke. This might be required especially for continuous operation, since the assembled choke has a low inductance value and small copper cross section.

Table 1 summarizes the maximum voltages that can be applied to the terminals of the Eval board.

**Table 1 Maximum voltages allowed on the Eval board's terminals**

Terminal	Description	Max. Value	Comment
AUX	Auxiliary voltage	17 V	Referenced to <b>SGND</b>
VIN+	Input voltage	650 V	Referenced to <b>VIN-</b>
Sig/Sig2	Sig/1Sig2	18 V	Referenced to <b>SGND</b>
TPOW+	Sig1/Sig2	12 V	Referenced to <b>TPOW-</b>

All measurement voltages on the board are referenced to **PGND**. To avoid disturbances on the sensing signal due to common mode noise, it is recommended to connect the terminal **PGND** directly to the oscilloscope's ground. This connection can be done through a cable wire of at least 2 mm<sup>2</sup>.

There are two versions of the Eval board. The model named EVAL-IGBT-650V-TO247-4-S includes an extra coaxial shunt for more accurate current measurement. There is an according place for it on the PCB, located between the emitter pin of the low side IGBT and the **VIN-** terminal. More details on the current sensing options are presented in section 3.4.

The Eval board has dimensions 130.2 mm x 171.5 mm x 72 mm (W x L x H) and includes a heat sink of about 100 mm x 29.4 mm x 45 mm. The thermal resistance is approximately 3.5 K/W between a TO-247 case and ambient.

### 3 Eval Board Hardware and Configuration

This chapter is about how to setup the hardware. It will enable the user to properly configure the Eval board according to the measurements intended.

#### 3.1 Package configuration: TO-247 and TO-247 4pin

The TO-247 4pin package has an extra Kelvin emitter connection. This bypasses the emitter lead inductance on the gate control loop, enhancing the IGBT’s switching speed and decreasing the switching energy [1]. The pinout of the TO-247 4pin is therefore different from the standard TO-247 as compared in Figure 5.

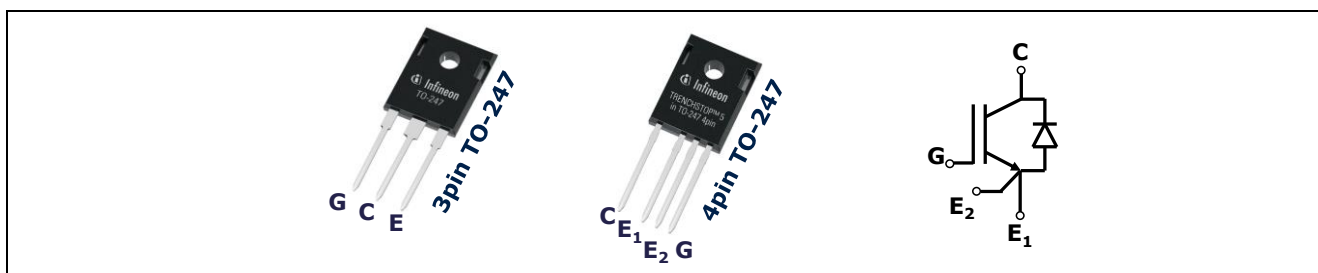

Figure 5 Pinout of standard TO-247 (left) and TO-247 4pin (center) packages; equivalent IGBT draw (right).

In order to accommodate both packages, the Eval board features dedicated 5 pin sockets, as depicted in Figure 6. Pins 1, 2, 3 and 5 feature 200 mils (5.08 mm) spacing horizontally from each other. Pin 4 distances 100 mils from pins 3 and 5.

To ease soldering and unsoldering of switches without damaging the PCB pads, the IGBT sockets contain pin adapters as pictured in Figure 6. An extra vertical distance of 100 mils (2.54 mm) is therefore required for pin 4.

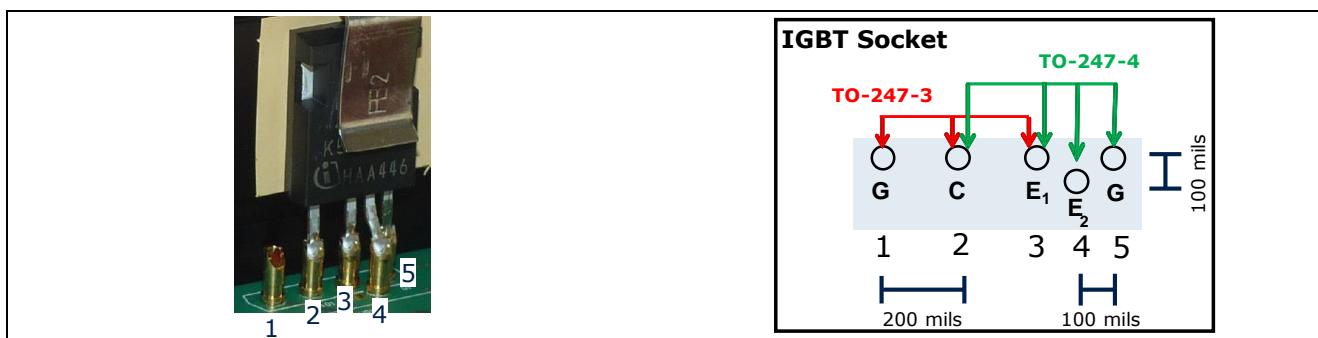

Figure 6 Detailed IGBT socket (left) and used pins according to assembled package (right)

Depending on which package is intend to be assembled, resistors R101 and R201 must be set as described in Table 2. Their location on the top side of the board can be seen in Figure 7.

Table 2 Proper configuration of R101 and R201 for TO-247 and TO-247 4pin packages

Switch	Package	Resistor	Resistance Value
S1	TO-247	R101	0 Ω
	TO-247 4pin	R101	Not assembled
S2	TO-247	R201	0 Ω
	TO-247 4pin	R201	Not assembled

The Eval board comes with IKZ50N65EH5 [2] parts assembled. This is a 50A IGBT from Infineon’s TRENCHSTOP™ 5 H5 family in TO-247 4pin package. Therefore, R101 and R201 are initially not assembled.

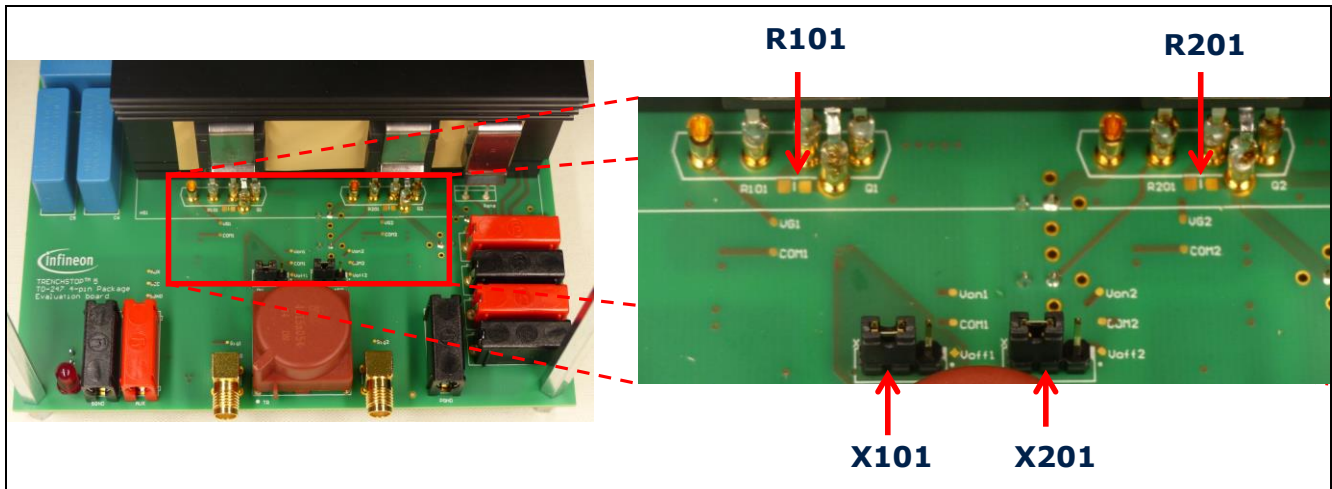

Figure 7 Front view to the Eval board (left) and detailed picture where the driver configuration resistors and jumpers are evidenced (right)

### 3.2 Gate Driver Configuration

A simplified schematic of the gate driver circuitry is depicted in Figure 8. Both pins 1 and 5 of the socket are connected to the gate pins of the TO-247 and the TO-247 4pin respectively. Separated resistors  $R_{g,on}$  and  $R_{g,off}$  are connected to the gate driver. An extra low pass filter composed of resistor  $R_f$  and capacitor  $C_f$ , initially not assembled, can be used to filter the gate signals if desired. The component numbers in the schematic are presented in Table 3Figure 9.

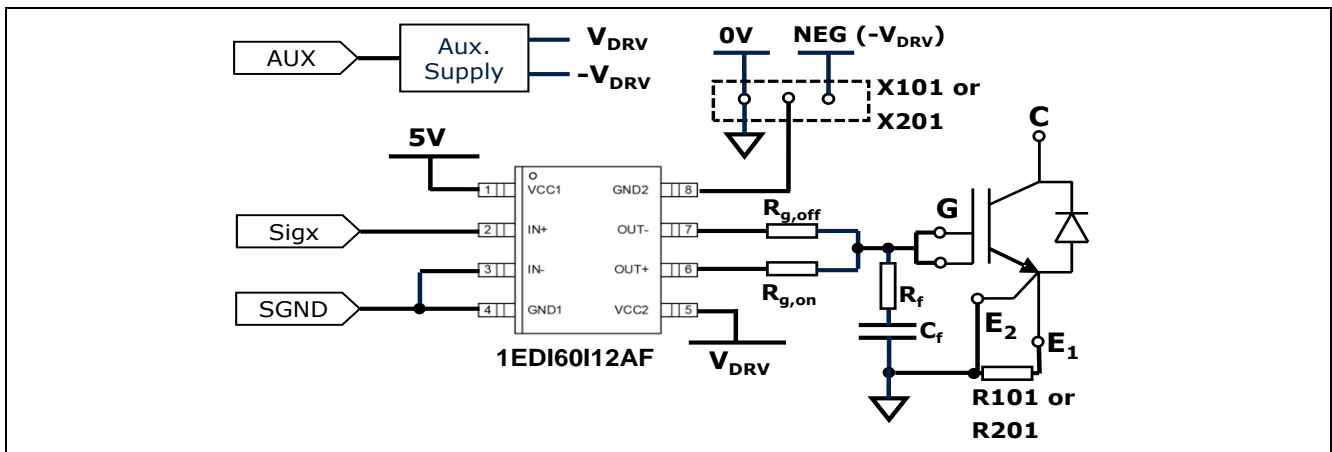

Figure 8 Simplified schematic of the gate driver circuitry

**Attention:** The jumpers X101 and X201 are initially positioned to “0V”. Please check that the jumpers are present on the board before any operation.

The gate voltages are defined by the auxiliary voltage  $V_{AUX}$ , between terminals AUX and SGND. In addition, the user has two possibilities for the turn-off gate voltage  $-V_{DRV}$ , according to the position of the jumpers X101 and X201. Their exact location on the top side of the PCB is shown in Figure 7.



When the jumper is set to “0V”,  $V_{g,off}$  is zero. The turn-off voltage is negative if the jumper is positioned at “NEG”, proportional to  $V_{AUX}$ . At  $V_{AUX}=13$  V, the turn-on voltage  $V_{DRV}$  will be 15V, and  $-V_{DRV}$  will be -7.5 V in case the jumper is set to “NEG”.

A summary with the component naming for the parts involved in the gate driver circuitry is presented in Table 3. It also lists the resulting driving voltages according to  $V_{AUX}$  and the position of jumpers **X101** and **X201**. For each  $R_{g,on}$  and  $R_{g,off}$  there is one extra pad; the names are given in brackets in Table 3. These pads are initially empty and can be used in case the original pads are damaged during evaluation.

**Table 3 Component numbers and jumper configuration of the gate driver circuitry, for both S1 and S2 switches**

Switch	Event	Gate Resistors	$V_{DRV} / -V_{DRV}$	Jumper	$R_f$	$C_f$
S1	turn-on	R111 (R112)	$1.15 \times V_{AUX}$	X101 set to “0V”	R131	C131
	Turn-off	R121 (R122)	0V	X101 set to “NEG”		
S2	Turn-on	R211 (R212)	$0.75 \times V_{AUX}$		R231	C231
	Turn-off	R221 (R222)	$0.57 \times V_{AUX}$	X201 set to “0V”		

Figure 9 highlights a detailed view of the bottom side of the Eval board. There the location of the components present in Table 3 is given.

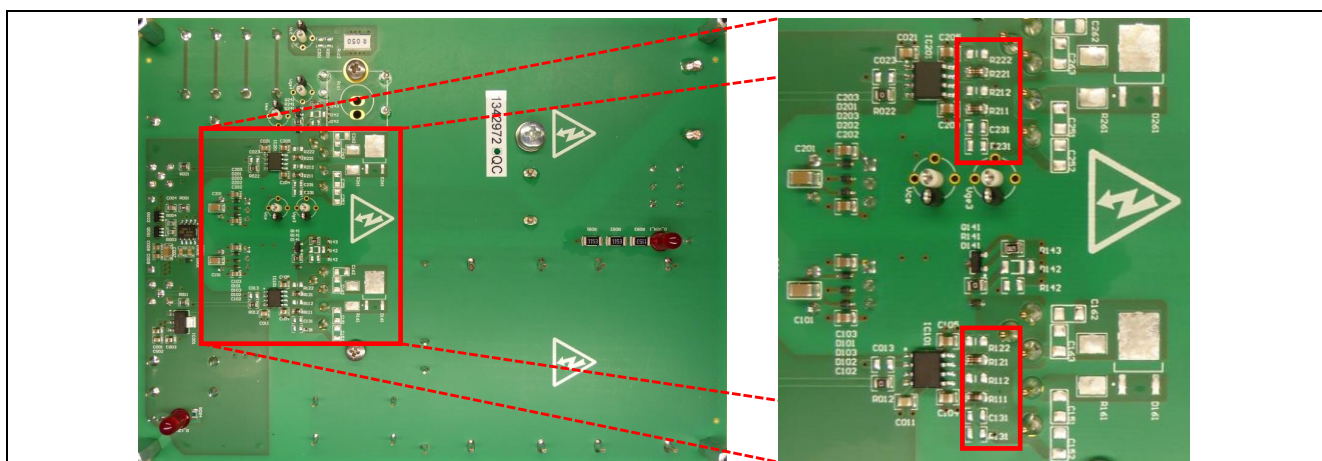

**Figure 9 Bottom view of the Eval board PCB (left) and detailed picture, where the components for the setup of gate circuitry are evidenced (right)**

### 3.3 Heat sink temperature setting and monitoring

To enable temperature controlled measurement, the Eval board contains a power resistor that can be used to heat up the heat sink. The relationship between the voltage applied to the resistor's terminals and the heat sink temperature is depicted in Figure 10. These values can be slightly different according to the ambient temperature and heat sink position with respect to any air flow.

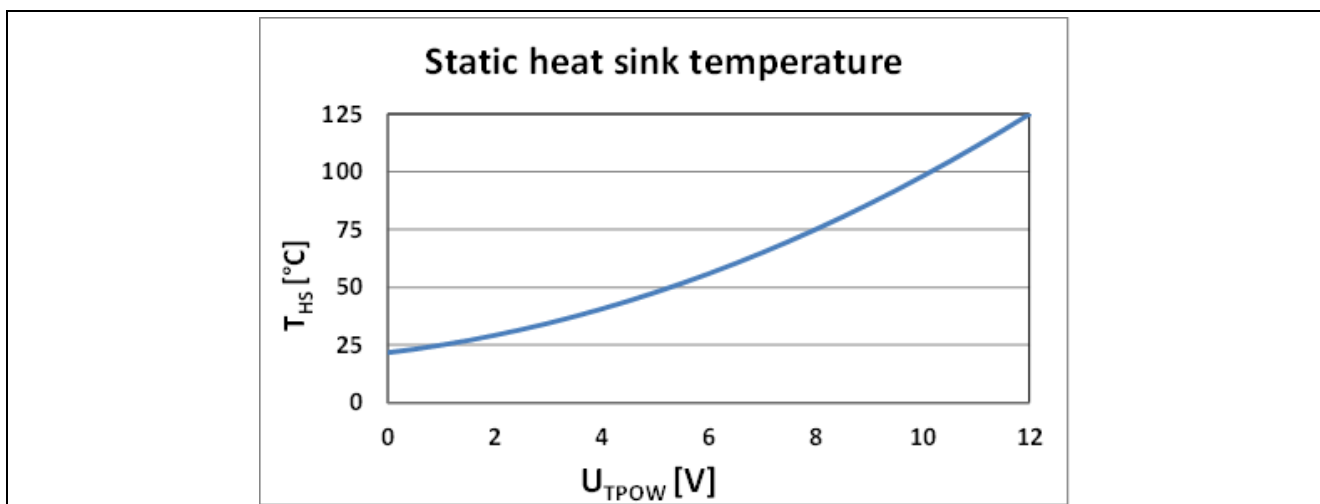

Figure 10 Heat sink temperature as a function of the applied voltage over the power resistor

An NTC sensor is assembled onto the heat sink besides the switches and can be used to sense and monitor the heat sink temperature. The sensor's resistance as function of the heat sink temperature is presented in Figure 11.

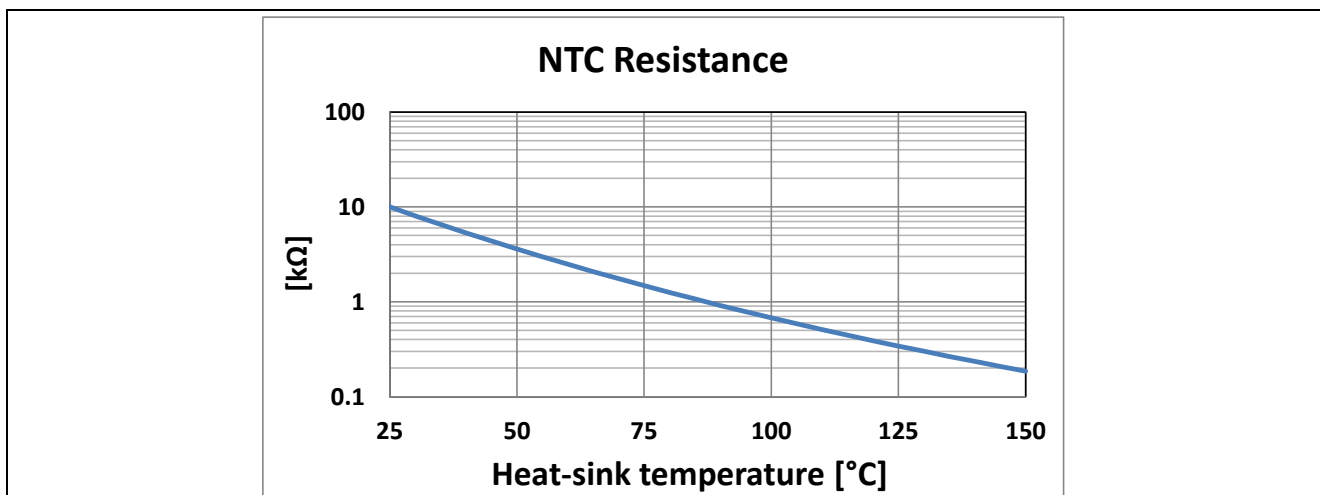

Figure 11 Resistance of the NTC resistor as function of the heat sink temperature (right)

### 3.4 Test points

The most relevant signals of the Eval board are available for measurement through test points. In total, there are five test points, all located on the bottom side of the Eval board as can be seen in Figure 12.

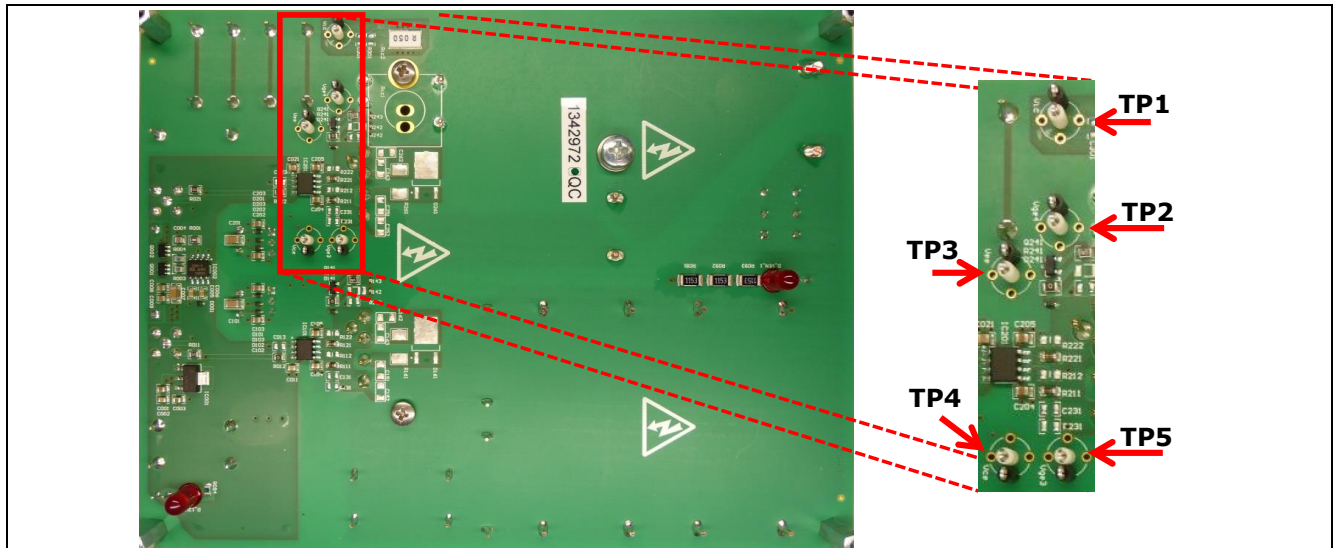



Figure 12 Detailed view of the test points on the back side of the Eval board

Table 4 contains the test points' identification names and description. The reference for all test points is the terminal **PGND**, which is connected to the emitter  $E_1$  of the low side switch **S2** as depicted in Figure 3.

Table 4 Test point identification names and description

Test point	Identification name	Description
TP1	$V_{ic}$	Filtered signal from metal foil shunt
TP2	$V_{ge4}$	Gate-emitter ( $E_1$ ) voltage of TO-247 4pin
TP3	$V_{ee}$	Voltage between $E_1$ and $E_2$ pins of TO-247 4pin
TP4	$V_{ce}$	Collector-emitter ( $E_1$ ) voltage
TP5	$V_{ge3}$	Gate-emitter voltage of standard TO-247

**Attention:**  In case non isolated probes are used for waveform measurement, the PGND terminal shall be used as the only reference for all oscilloscope channels.

### 3.5 Current sensing

There are two possibilities to measure the emitter current of **S2** in the Eval board. A metal foil resistor is initially assembled in the Eval board. It has a resistance of 50 mΩ typical and is labeled **Ric2**. Its location is presented in Figure 14. A low pass RC filter, composed by **R301** and **C301**, is connected in parallel to **Ric2**.

For a correct sensing of the emitter current, it is recommended to use the probe adapter contained in the Eval board's case. This avoids oscillations and enables a more accurate measurement of the switching energy. This adapter shall be soldered on the test point **TP1**; please refer to Figure 12. Figure 13 shows how the oscilloscope probe shall be connected through the adapter.

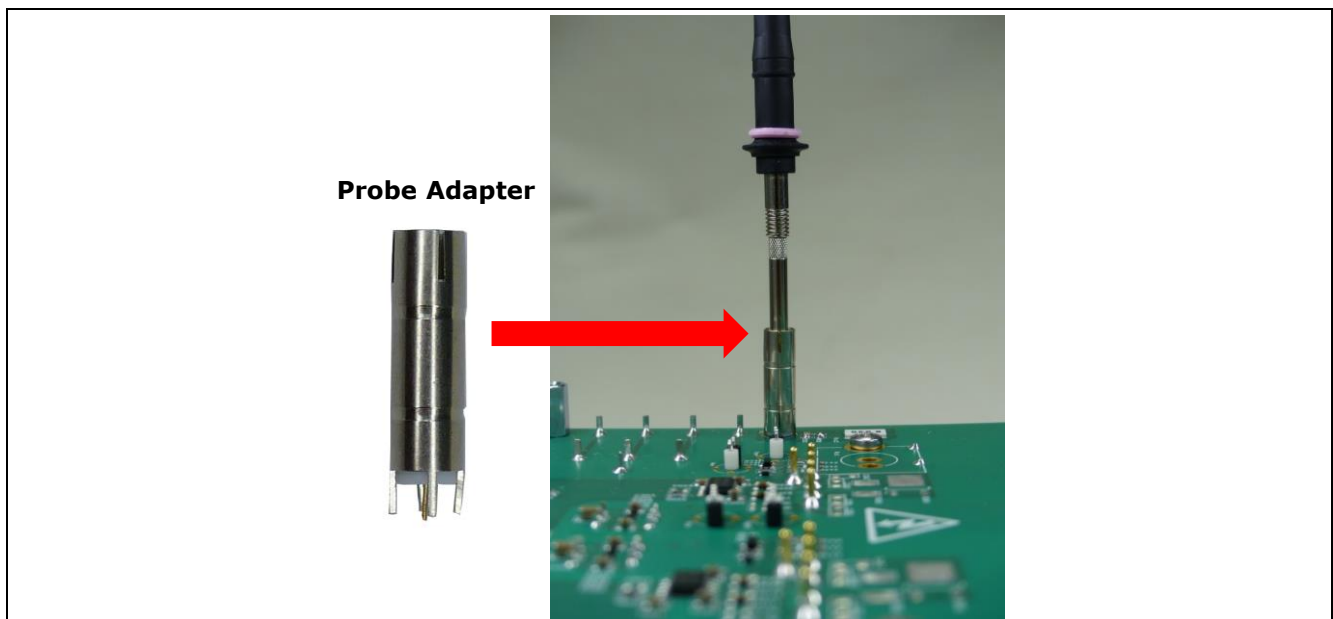

Figure 13 Probe adapter soldered on the Eval board

As an alternative to the metal foil resistor, a coaxial shunt can be used for current measurement. The model  **EVAL-IGBT-650V-TO247-4-S**  contains a suitable shunt. The location of the shunt pad is shown in Figure 14. Before the coaxial shunt is used, unsolder the foil shunt resistor **Ric2** and the resistor **R301**. They are both highlighted in Figure 14.

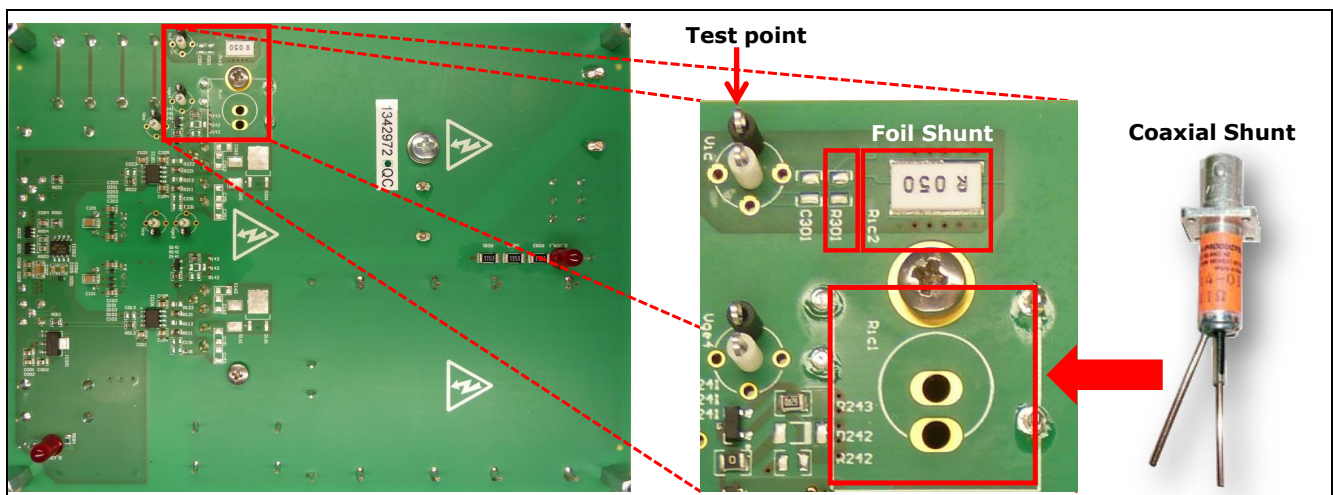

Figure 14 Detailed view of the test point **Vic** and where to connect the coaxial shunt

### 3.6 Configurable circuit topologies

The Eval board is adaptable to operate in different circuit topologies. Table 5 summarizes the main circuit configurations that can be used for different kinds of measurement.

Table 5 Configurable circuit topologies with the Eval board

Configuration	Measureable results	Topology
<p><b>Conf. 1</b> <b>Switching Cell</b></p>	<p><math>E_{ON}</math> and <math>E_{OFF}</math> at defined:</p> <ul style="list-style-type: none"> <li>- <math>I_C</math> (max 150 A)</li> <li>- <math>V_{CE}</math> (max 650V)</li> <li>- <math>T_C</math> (max 125°C)</li> <li>- <math>R_g</math></li> </ul>	
<p><b>Conf. 2</b> <b>Switching Cell using coaxial shunt (opt.)</b></p>		
<p><b>Conf. 3</b> <b>Step-up Converter</b></p> <ul style="list-style-type: none"> <li>- <math>V_{OUT,MAX}=520V</math></li> <li>- <math>P_{o,MAX}=2kW</math></li> <li>- (limited by <math>T_j</math>)</li> </ul>		
<p><b>Conf. 4</b> <b>Step-down Converter</b></p> <ul style="list-style-type: none"> <li>- <math>V_{IN,MAX}=520V</math></li> <li>- <math>P_{o,MAX}=2kW</math></li> <li>- (limited by <math>T_j</math>)</li> </ul>		

In **Conf. 1** and **Conf. 2**, the Eval board will operate as a switching cell. In these configurations, losses during switching events can be measured, varying load current  $I_C$  and supply voltage  $V_{DC}$ .

To test the Eval board in **Conf. 1** or **Conf. 2**:

1. Set **R101** and **R201** according to the package tested, please refer to Table 2
2. Set gate resistors  $R_{g,on}$  and  $R_{g,off}$  using Table 3 as a reference
3. Connect a voltage source between terminals **AUX** and **SGND**. This is the voltage  $V_{AUX}$  that in combination with jumpers **X101** and **X102** defines the driving voltages as described in Table 3
4. Connect a voltage source between **TPOW+** and **TPOW-** to set the heat sink temperature, using the left graph of Figure 10 as reference
5. Measure waveforms of **S2** through test points as described in Table 4
6. Only for **Conf. 2**: Place the coaxial shunt as depicted in Figure 13. More details to be found in section 4.2
7. Connect a signal generator to terminal **Sig2** to provide the double pulse signals
8. Connect a DC voltage source  $V_{DC}$  between terminals **VIN+** and **VIN-**.

In **Conf. 3** and **Conf. 4** of Table 5, the Eval board operates as a DC-DC converter in continuous operation. In this case, an extra inductor shall be connected in series to the assembled choke.

To test the Eval board in **Conf. 3**:

1. Set **R101** and **R201** according to the package of the tested package, please refer to Table 2
2. Set gate resistors  $R_{g,on}$  and  $R_{g,off}$  using Table 3 as reference
3. Connect a voltage source between terminals **AUX** and **SGND**. This is the voltage  $V_{AUX}$  that, in combination with jumpers **X101** and **X102** defines the driving voltages as described in Table 3. In order to avoid disturbances on the gate of **S1** it is recommended to set **X101** to **NEG**.
4. Place an external inductor choke **Ext. L**, able to handle the desired current
5. Measure waveforms of **S2** through test points as described in Table 4
6. Connect a signal generator to terminal **Sig2** to provide gate signals for **S2**
7. Connect a DC voltage source  $V_{DC}$  between the external choke **Ext. L** and terminal **VIN-**; put a load between terminals **VIN+** and **VIN-**.

To test the Eval board in **Conf. 4**:

1. Set **R101** and **R201** according to the tested package, as given in Table 2;
8. Connect a voltage source between terminals **AUX** and **SGND**. This the voltage  $V_{AUX}$  that, in combination with jumpers **X101** and **X102** defines the driving voltages, as described in Table 3 Figure 9. In order to avoid disturbances on the gate of **S2**, it is recommended to set **X102** to **NEG**;
2. Set gate resistors  $R_{g,on}$  and  $R_{g,off}$  using Table 3 as reference
3. Place an external inductor choke **Ext. L**, able to handle the required current
4. Measure waveforms of **S2** through test points, as described in Table 4. Waveforms of **S1** must be measured with isolated probes.
5. Connect a signal generator to terminal **Sig1** to provide gate signals for **S1**
6. Connect a DC voltage source  $V_{DC}$  between terminals **VIN+** and **VIN-**; put a load between the choke **Ext. L** and terminal **VIN-**.

## 4 Measurements with the Eval board

In the delivered setup, the Eval board is configured to accommodate switches in TO-247 4pin package. Thus, resistors **R101** and **R102** are not assembled and the jumpers **X101** and **X102** are placed in the “0V” position as in Figure 7.

**Attention:**  Before any operation with the Eval board, please check that the jumpers **X101** and **X201** are present and positioned to “0V”. They could have gotten lost or fallen off during transportation.

### 4.1 Measurement in switching cell configuration

For the operation as switching cell – **Conf. 1** of Table 5 – the assembled inductor can be used. Its inductance value is a function of current as shown in Figure 15. Up to 32A, the value is 85  $\mu\text{H}$ . At higher current levels, the inductance starts to decay exponentially down to 20  $\mu\text{H}$  at 150 A.

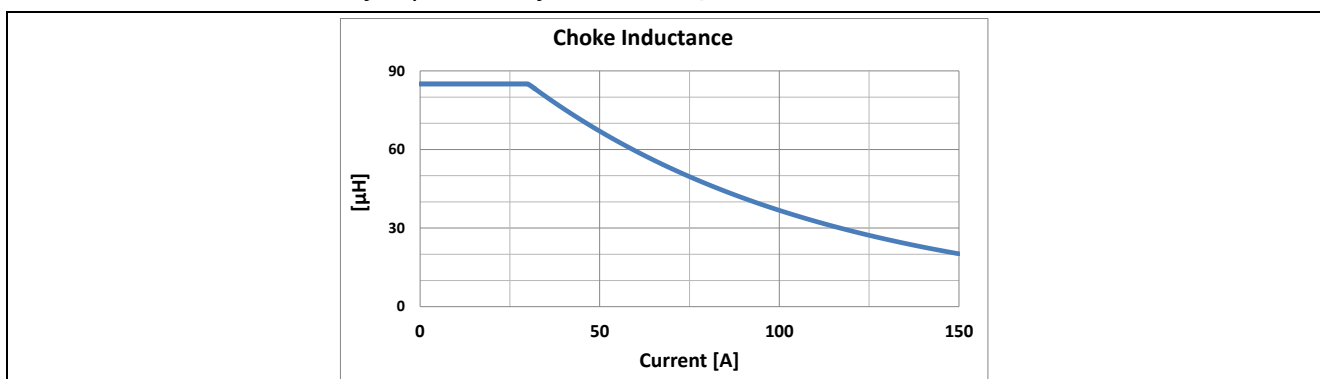

Figure 15 Inductance of the assembled choke as function of current

After setting the voltage  $V_{\text{DC}}$  of the power supply, the double pulse must be provided by the signal generator. The length of the first pulse will depend on the required current to be switched as depicted on Figure 16. Assuming a DC voltage  $V_{\text{DC}}=400\text{V}$ , a pulse length of  $t_p=10\ \mu\text{s}$  results in a switched current of  $I_{\text{SW}}=50\text{A}$ , while  $t_p=20\ \mu\text{s}$  results in  $I_{\text{SW}}=150\text{A}$ .

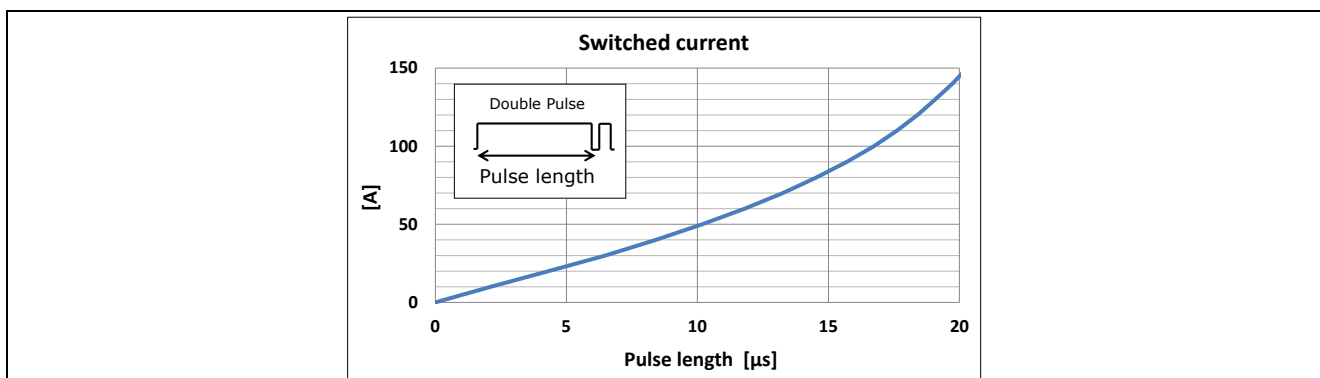

Figure 16 Inductor current as function of pulse length for  $V_{\text{DC}}=400\ \text{V}$

### 4.2 Measurement using a coaxial shunt

The Eval board EVAL-IGBT-650V-TO247-4-S contains a coaxial shunt of 25  $\text{m}\Omega$ . Please consider the instruction in section 3.5 on how to assemble it.

Terminals **VIN+**, **VIN-** and **VL** must be connected as in Conf. 2 of Table 5. The assembled inductor can also be used with the coaxial shunt. The graph in is valid to determine the switched current.

Figure 17 presents a test bench configured as Conf. 2. The auxiliary supply provides  $V_{AUX}$  and the voltage to the power resistor. The NTC sensor is measured through a multimeter. The double pulse signal to **Sig2** is given by a signal generator. The current signal coming from the shunt is connected to the oscilloscope through a coaxial cable, featuring an impedance of 50 Ω. All other waveforms are taken by non isolated probes from the test points on the PCB.

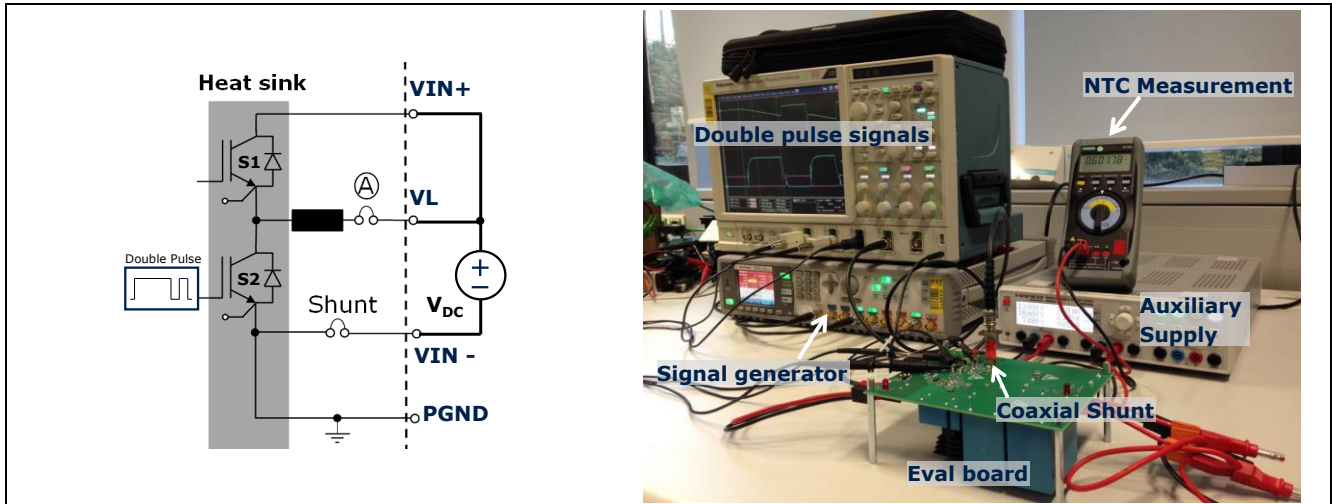

Figure 17 Eval board test bench in Conf. 2

Figure 18 shows the difference in the waveforms coming from the metal foil shunt used in Conf. 1 and the coaxial shunt in Conf. 2 in both, turn-on and turn-off events, for different values of switched current. This difference is mainly coming from the different bandwidth of the sensor.

In order to compensate the parasitic inductance of the measurement loop, the signal coming from the foil shunt must be filtered using resistor R301 and capacitor C301 on the PCB. The cut-off frequency of the filter is calculated to be 7.2 MHz. The coaxial shunt instead has a 1.2 GHz bandwidth.

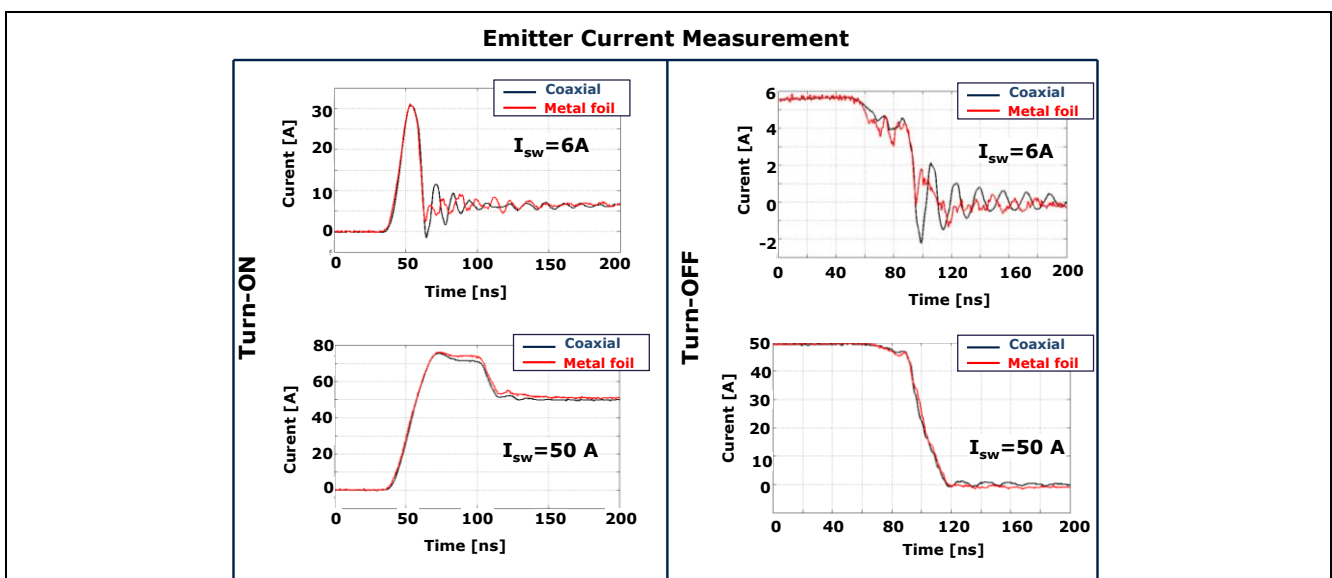

Figure 18 Measured waveforms of the emitter current of an IKW50N65EH5 IGBT. Turn-on events are depicted on the left side, turn-off on the right side, using both coaxial and metal foil shunts, for different current values



### 4.3 Comparison between TO-247 4pin and standard TO-247

In order to test switches in standard TO-247 package with the Eval board:

1. Unsolder the switches in TO-247 4 pin package
2. Solder 0 Ω resistors on both R101 and R102 – refer to Figure 7
3. Solder the switches in standard TO-247

The Eval board has been used to compare the switching behavior of the IKZ50N65EH5 in TO-247 4pin and IKW50N65H5 as a standard TO-247 IGBT. The operation conditions are summarized in Table 6 Figure 19. The gate resistors  $R_{g,on}$  and  $R_{g,off}$  have been chosen so that the transient overvoltage across the switch and the co-packed diode were lower than 520 V.

**Table 6 Test conditions for the comparison between IKZ50N65EH5 and IKW50N65H5**

Parameter	Description	Device	Value	Unity
$V_{SW}$	Switched voltage		400	V
$I_{SW}$	Switched current		50	A
$T_j$	Junction temperature		25	°C
$V_{DRV}$	Turn-on voltage		15	V
$-V_{DRV}$	Turn-off voltage		0	V
$R_{g,on}$	Turn-on gate resistor	IKW50N65H5	6	Ω
		IKZ50N65EH5	10	
$R_{g,off}$	Turn-off gate resistor	IKW50N65H5	10	
		IKZ50N65EH5	23	

Figure 19 contains waveforms of both parts tested. During turn-on, it is possible to see how the switching time is increased in the 3pin configuration. This leads to additional 600 μJ turn-on energy when compared to the same die in 4pin package, representing an increase by 60%. The energy reduction introduced by TO-247 4pin package can differ according to the measurement conditions like current switched, temperature and PCB layout. Basically, the faster the IGBT is able to switch, the bigger the benefit from TO-247 4pin becomes.

During turn-off, the emitter current waveform exhibits the effect of the parasitic emitter inductance. The fall time of the emitter current almost doubles in the IKZ50N65EH5 when compared to the IKW50N65H5. This leads to higher switching energy during turn-off.

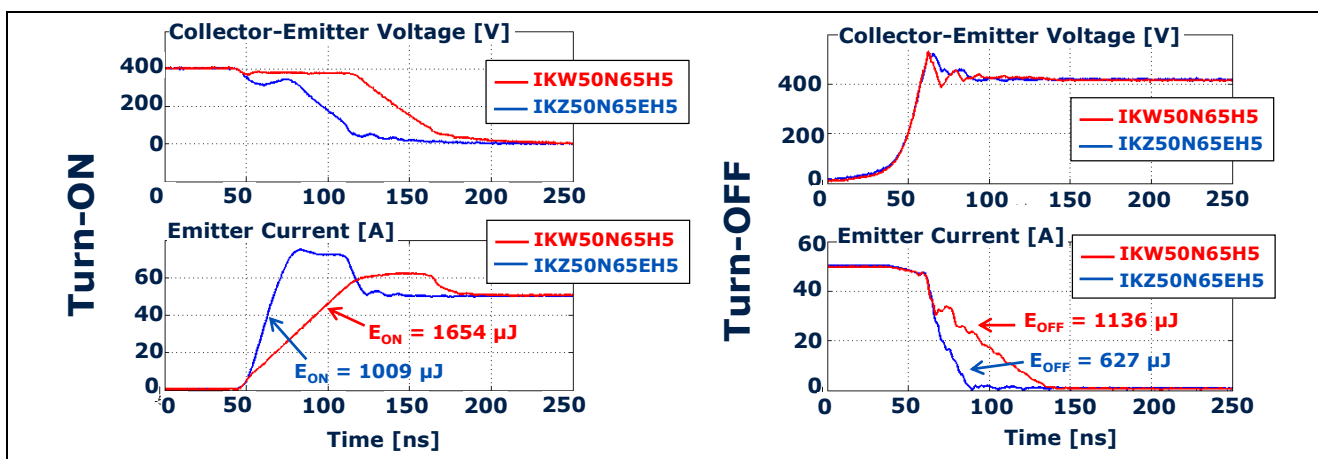

**Figure 19 Measured waveforms of an IKW50N65EH5 IGBT during turn-on (left) and turn-off (right) at  $I_c=50$  A and  $T_c=25^\circ\text{C}$ , in both, 4-pin and 3-pin configurations**

### 4.4 Operation as a step-down DC-DC converter

For operation of the Eval board as a step-down DC-DC converter, terminals **VIN+**, **VIN-** and **VL** must be connected as in Conf. 4 of Table 5. In addition, it is recommended to connect the terminals of the assembled inductor and the current shunts, so that they do not conduct current during operation.

The maximum power the Eval board can process is limited by the chips' junction temperature. Internal tests using IKZ50N65EH5 devices as switches **S1** and **S2** revealed that the Eval board can process up to 2 kW at a switching frequency of 20 kHz, input voltage 400 V and duty cycle 50%.

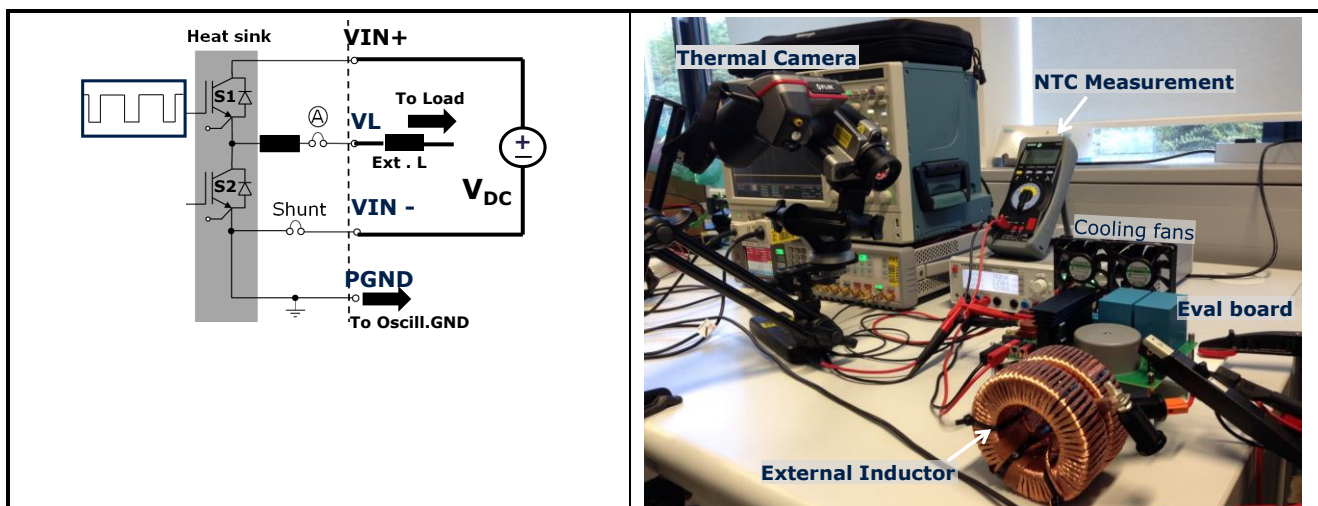

Figure 20 Eval board test bench in Conf. 4

To handle higher power, external cooling fans can be positioned aside the heat sink. Figure 20 shows a combination of four fans, each of them fed with 12 V. This is clearly an excessive cooling and was only done to enable the operation under higher power and current, closer to the rated value of the tested IGBTs. Alternatively, a bigger heat sink with lower thermal resistance could be used.

With extra cooling it is possible to operate the Eval board up to 6 kW, either with IKW50N65H5 or IKZ50N65EH5 IGBTs as **S1** and **S2**. Main operation conditions are summarized in Table 7.

Table 7 Test conditions for the comparison between IKZ50N65EH5 and IKW50N65H5

Parameter	Description	Device	Value	Unity
$V_{IN}$	Input voltage		400	V
$V_{OUT}$	Output voltage		200	V
$P_{OUT}$	Output power		6	kW
$f_{sw}$	Junction temperature		20	kHz
$V_{DRV}$	Turn-on gate voltage		15	V
$-V_{DRV}$	Turn-off gate voltage		0	V
$R_{g,on}$	Turn-on gate voltage	IKW50N65H5	6	$\Omega$
		IKZ50N65EH5	10	
$R_{g,off}$	Turn-off gate resistor	IKW50N65H5	10	
		IKZ50N65EH5	23	

To compare the difference in temperature and losses between IKZ50N65EH5 and IKW50N65H5, a thermal camera and a power meter have been used. Figure 21 presents thermal pictures of the switches under operation. The case temperature of switches S1 and S2 are inside areas 1 and 2 of the pictures, respectively.

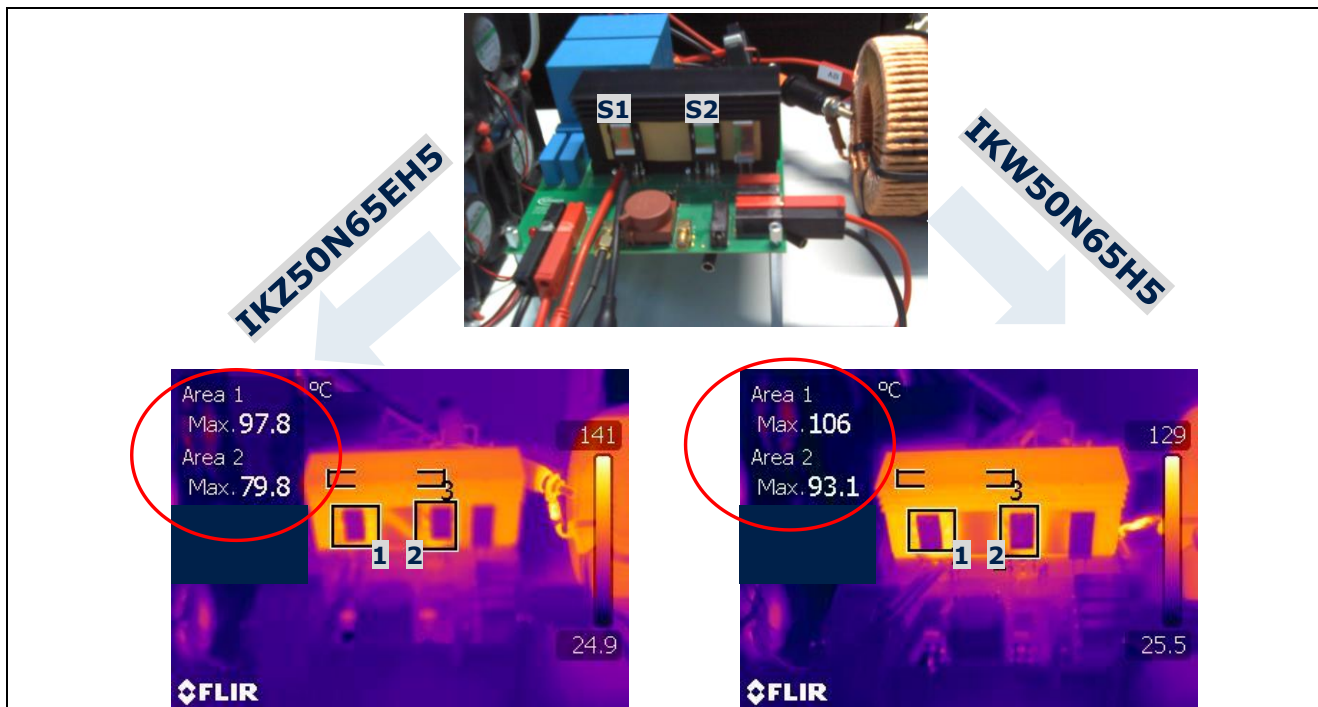

Figure 21 Thermal pictures of the Eval board tested with IKZ50N65EH5 (left) and IKW50N65H5 (left) IGBT devices

Table 8 presents the main test results of the Eval board operating on the conditions described in Table 7. The case temperatures listed in were measured using the thermal camera as described above. The heat sink temperature was measured with the NTC sensor available on the Eval board. Values for efficiency and losses are determined by the power meter. Losses from the auxiliary supply and the power consumed by the cooling fans are not included.

Table 8 Results of the Eval board operating as a step-down converter for different IGBT devices

Devices	T <sub>c</sub> (S1) [°C]	T <sub>c</sub> (S2) [°C]	T <sub>hs</sub> [°C]	Converter Losses <sup>1</sup> [W]	Converter Efficiency <sup>1</sup> [%]
IKW50N65H5	97.8	106	83.1	237.0	96.10
IKZ50N65EH5	79.8	93.1	77.1	222.1	96.35
IKZ50N65NH5	76.1	90.4	74.3	220.5	96.38

<sup>1</sup> Converter losses and efficiency neither include losses due to the auxiliary supply nor the cooling effort

IKZ50N65EH5 in TO-247 4pin presented lower operation temperature and slightly higher efficiency in comparison to IKW50N65H5. In addition IKZ50N65NH5 [2], which has a Rapid 2 co-packed diode, presented 2 W lower losses and operated at a temperature 3K lower than the IKZ50N65EH5.



## 5 References

- [1] [TRENCHSTOP™ 5 IGBT in a Kelvin Emitter Configuration](#)
- [2] [www.infineon.com/to-247-4](http://www.infineon.com/to-247-4)
- [3] [1EDI60I12AF webpage](#)

# Appendix

## A.1 PCB Schematic

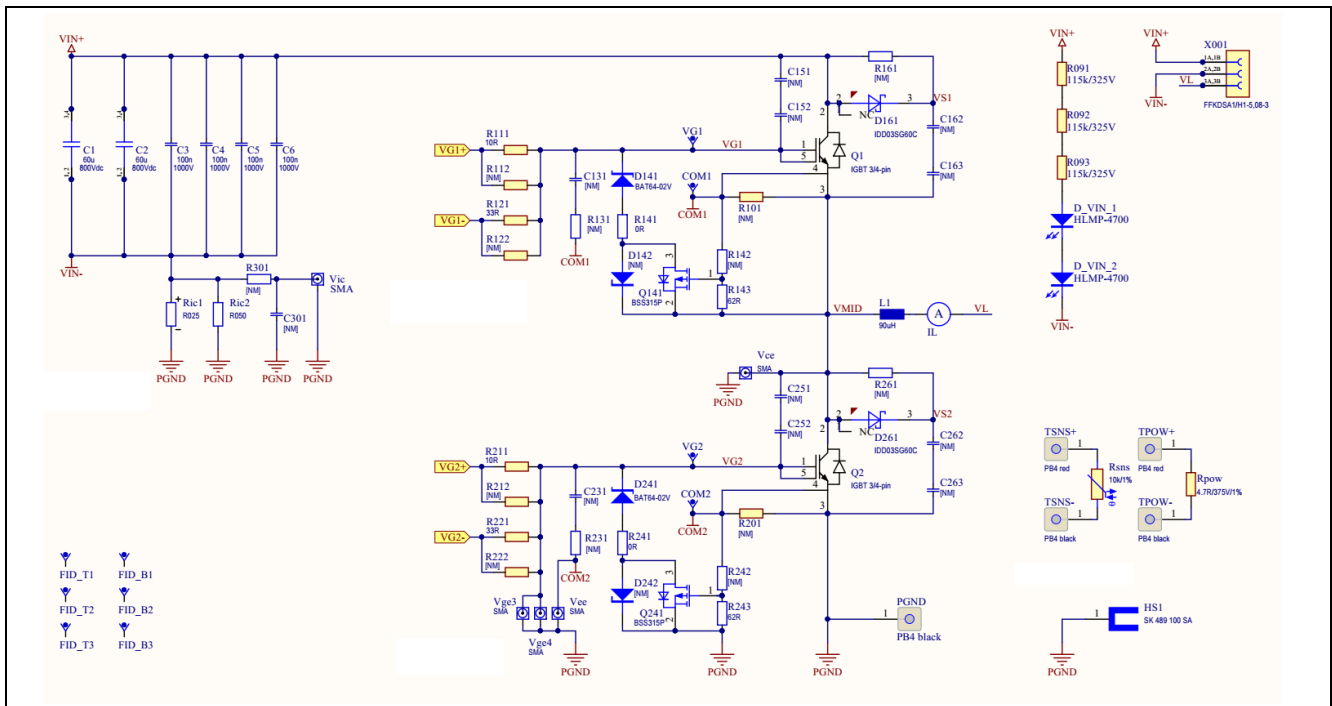

Figure 22 Circuit schematic of the power circuitry

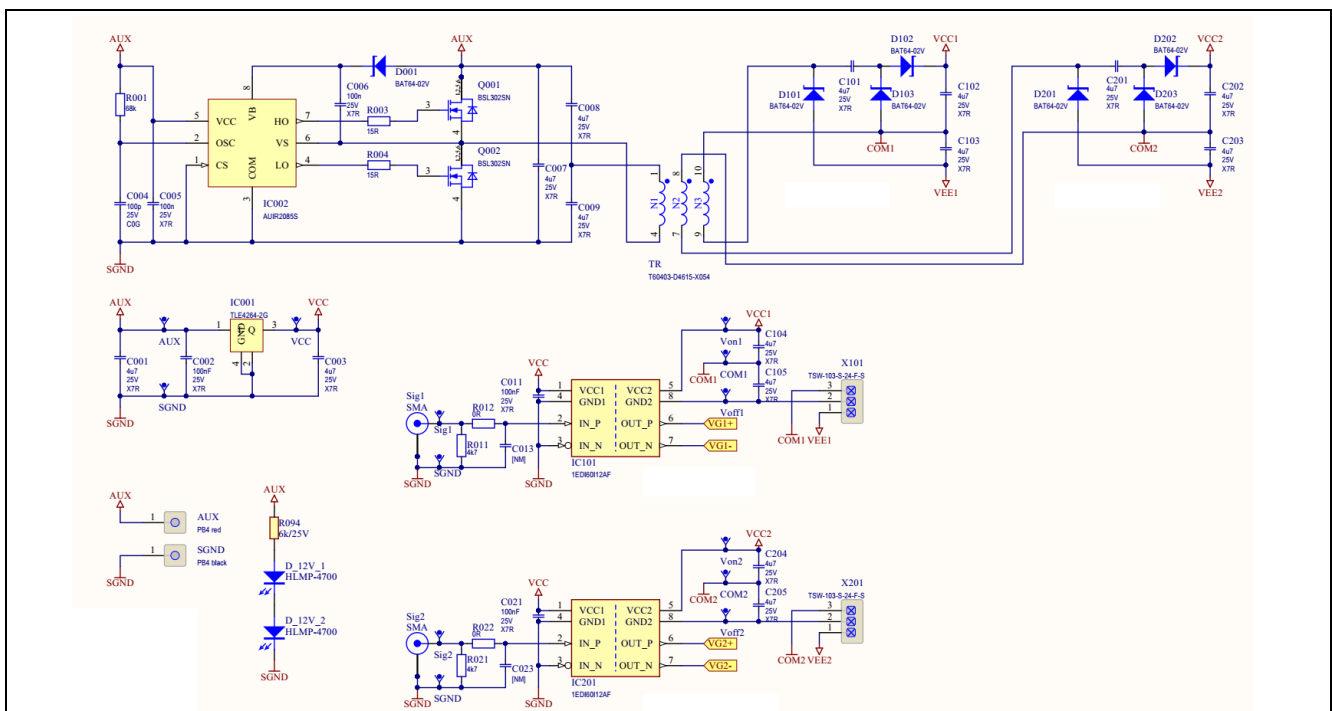

Figure 23 Circuit schematic of the auxiliary power supply

## A.2 Bill of Material

Table 9 Bill of materials of the Eval board

Designator	Description	Value	Voltage	Footprint
C001	Capacitor Ceramic	4u7	25V	C 0805
C002	Capacitor Ceramic	100n	25V	C 0805
C003	Capacitor Ceramic	4u7	25V	C 0805
C004	Capacitor Ceramic	100p	25V	C 0805
C005	Capacitor Ceramic	100n	25V	C 0805
C006	Capacitor Ceramic	100n	25V	C 0805
C007	Capacitor Ceramic	4u7	25V	C 1206
C008	Capacitor Ceramic	4u7	25V	C 0805
C009	Capacitor Ceramic	4u7	25V	C 0805
C011	Capacitor Ceramic	100n	25V	C 0805
C021	Capacitor Ceramic	100n	25V	C 0805
C101	Capacitor Ceramic	4u7	25V	C 1206
C102	Capacitor Ceramic	4u7	25V	C 0805
C103	Capacitor Ceramic	4u7	25V	C 0805
C104	Capacitor Ceramic	4u7	25V	C 0805
C105	Capacitor Ceramic	4u7	25V	C 0805
C201	Capacitor Ceramic	4u7	25V	C 1206
C202	Capacitor Ceramic	4u7	25V	C 0805
C203	Capacitor Ceramic	4u7	25V	C 0805
C204	Capacitor Ceramic	4u7	25V	C 0805
C205	Capacitor Ceramic	4u7	25V	C 0805
C301	Capacitor Ceramic	470p	25V	C 0805
C1	Capacitor Film	60u	800V	
C2	Capacitor Film	60u	800V	
C3	Capacitor Film	100n	1000V	
C4	Capacitor Film	100n	1000V	
C5	Capacitor Film	100n	1000V	
C6	Capacitor Film	100n	1000V	
X101	Header			
X201	Header			
C105	Capacitor Ceramic	4u7	25V	C 0805
C201	Capacitor Ceramic	4u7	25V	C 1206
C202	Capacitor Ceramic	4u7	25V	C 0805
C203	Capacitor Ceramic	4u7	25V	C 0805
C204	Capacitor Ceramic	4u7	25V	C 0805
C205	Capacitor Ceramic	4u7	25V	C 0805
C1	Capacitor Film	60u	800V	
C2	Capacitor Film	60u	800V	
C3	Capacitor Film	100n	1000V	
C4	Capacitor Film	100n	1000V	
C5	Capacitor Film	100n	1000V	
C6	Capacitor Film	100n	1000V	
X101	Header			

## Appendix

Designator	Description	Value	Voltage	Footprint
X201	Header			
HS1	Heat sink			
IC001	Voltage Regulator 5V			SOT223
IC002	Half bridge Driver			8-Lead SOIC
IC101	IGBT driver, $\pm 6.0$ A			DSO-8-51
IC201	IGBT driver, $\pm 6.0$ A			DSO-8-51
L1	Inductor	90u		
D_12V_1	LED			
D_12V_2	LED			
D_VIN_1	LED			
D_VIN_2	LED			
R111	Resistor MELF	10R		MELF 0102
R121	Resistor MELF	33R		MELF 0102
R211	Resistor MELF	10R		MELF 0102
R221	Resistor MELF	33R		MELF 0102
Ric2	Resistor Metal Foil	R050		
Rsns	Thermistor NTC	10k		TO-220
Rpow	Resistor Power	4R7		TO-247
R001	Resistor Thick Film	68k		R 0805
R003	Resistor Thick Film	15R		R 0805
R004	Resistor Thick Film	15R		R 0805
R011	Resistor Thick Film	4k7		R 0805
R012	Resistor Thick Film	0R		R 0805
R021	Resistor Thick Film	4k7		R 0805
R022	Resistor Thick Film	0R		R 0805
R091	Resistor Thick Film	115k	400V	R 2010
R092	Resistor Thick Film	115k	400V	R 2010
R093	Resistor Thick Film	115k	400V	R 2010
R094	Resistor Thick Film	5k9		R 0805
R301	Resistor Thick Film	47R		R 0805
D001	Silicon Schottky Diode			SC79
D101	Silicon Schottky Diode			SC79
D102	Silicon Schottky Diode			SC79
D103	Silicon Schottky Diode			SC79
D201	Silicon Schottky Diode			SC79
D202	Silicon Schottky Diode			SC79
D203	Silicon Schottky Diode			SC79

### .3 Board layers

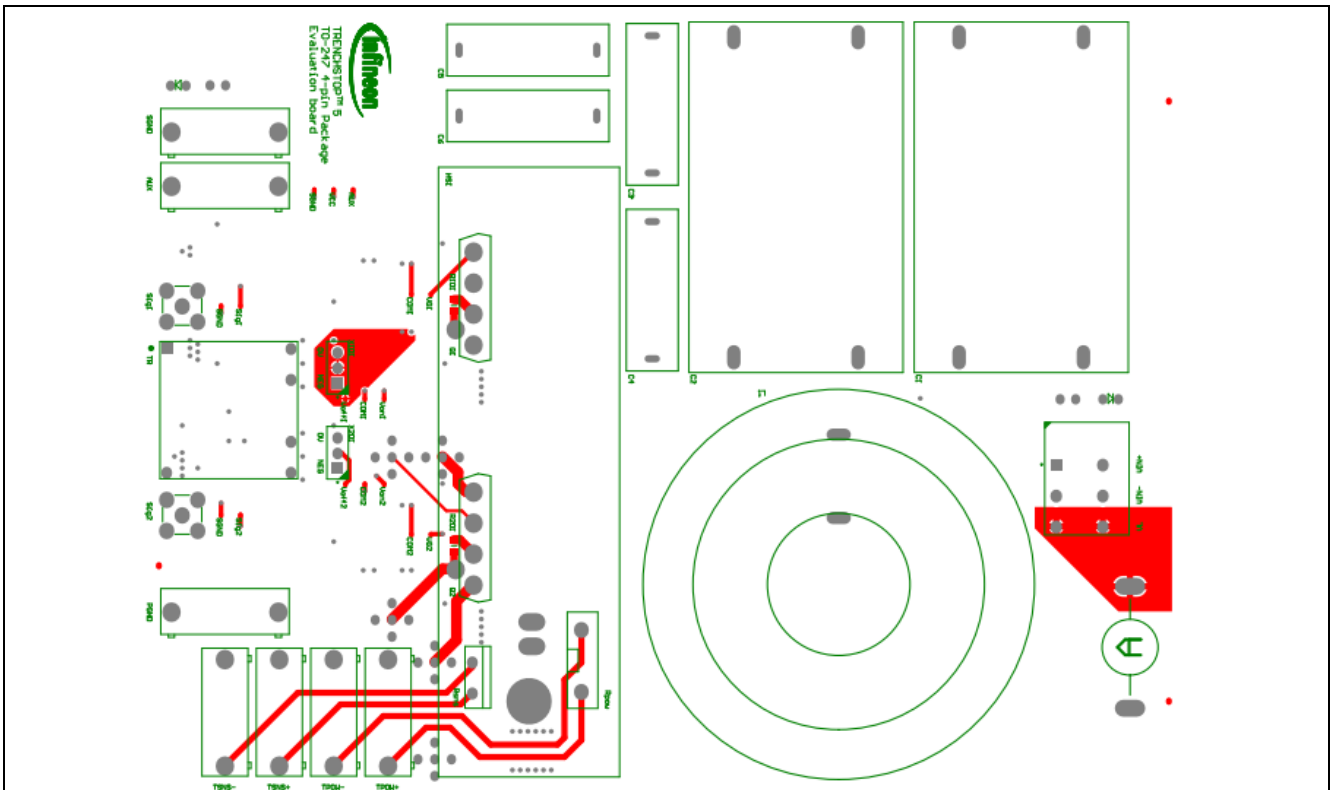

Figure 24 Top layer

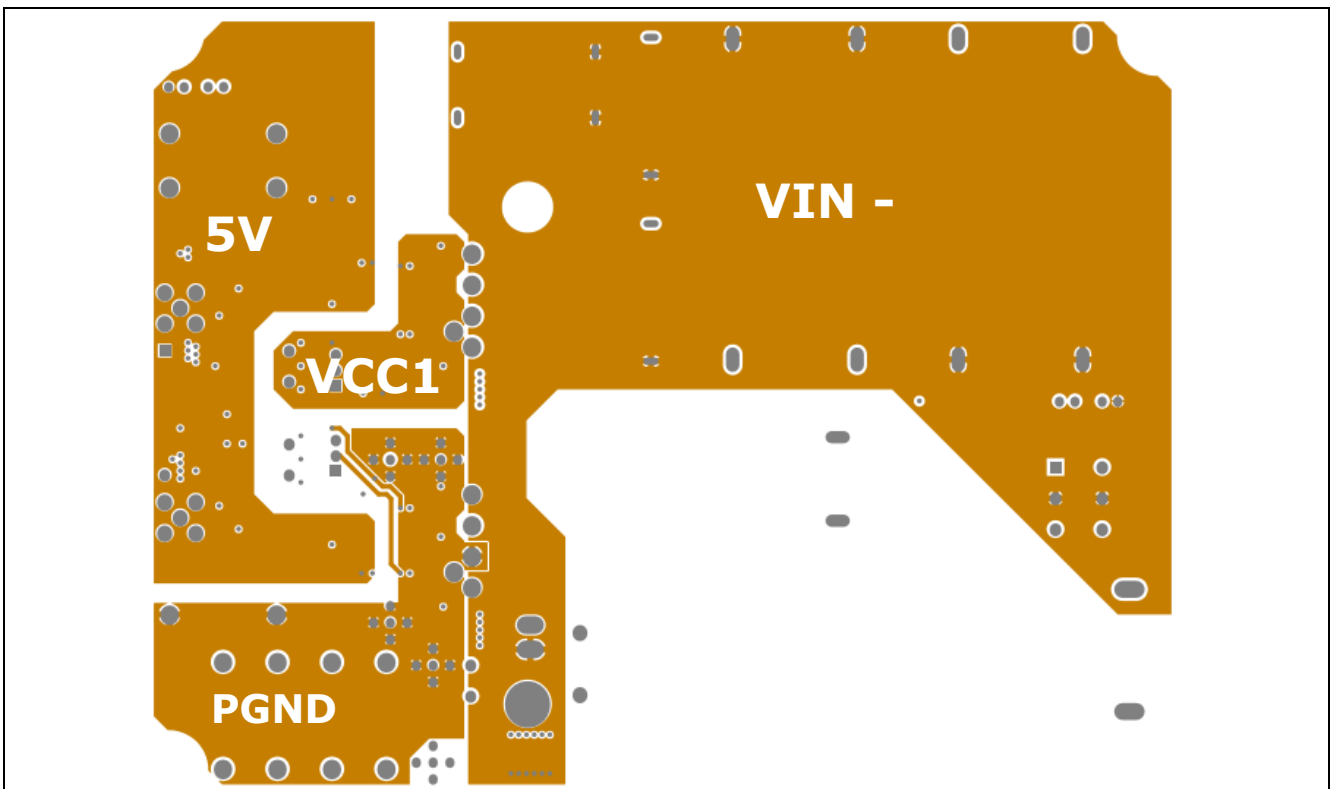

Figure 25 Internal layer 1



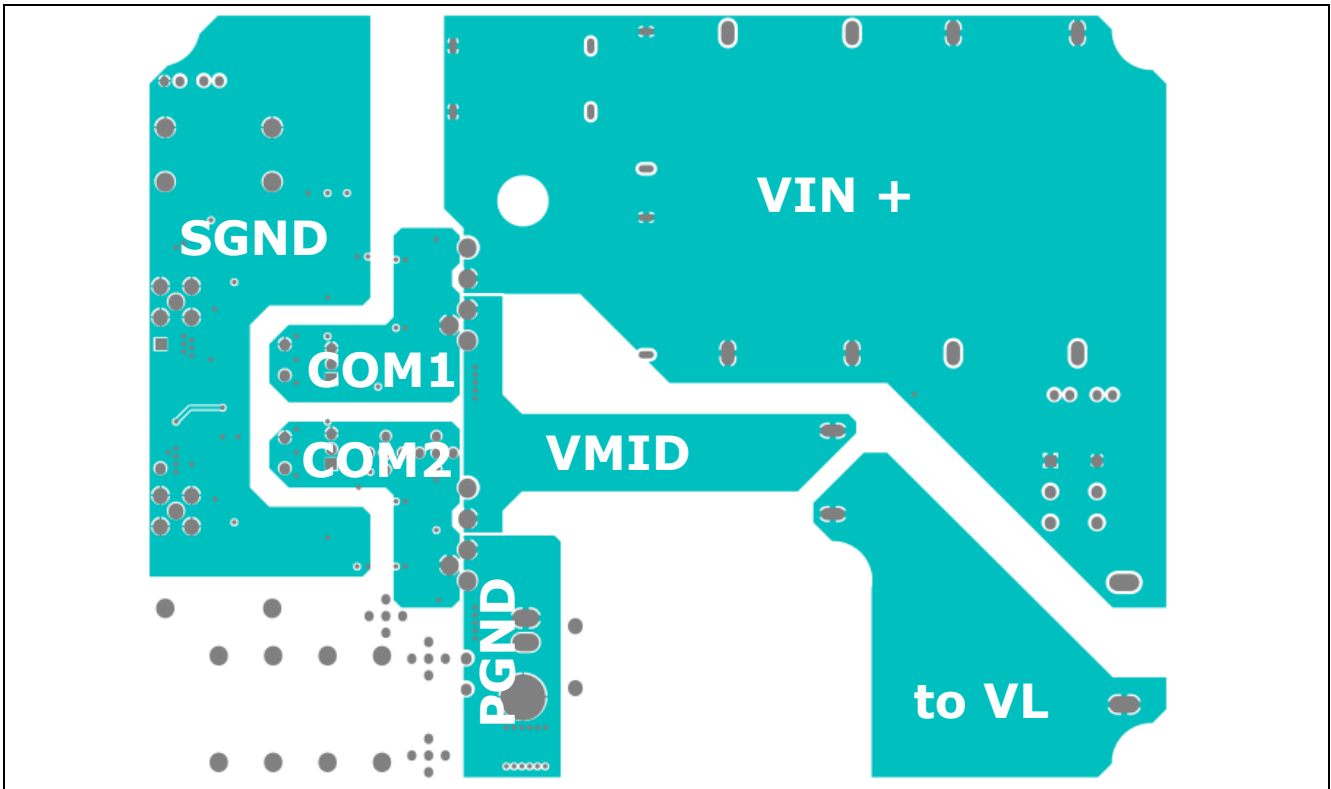

Figure 26 Internal layer 2

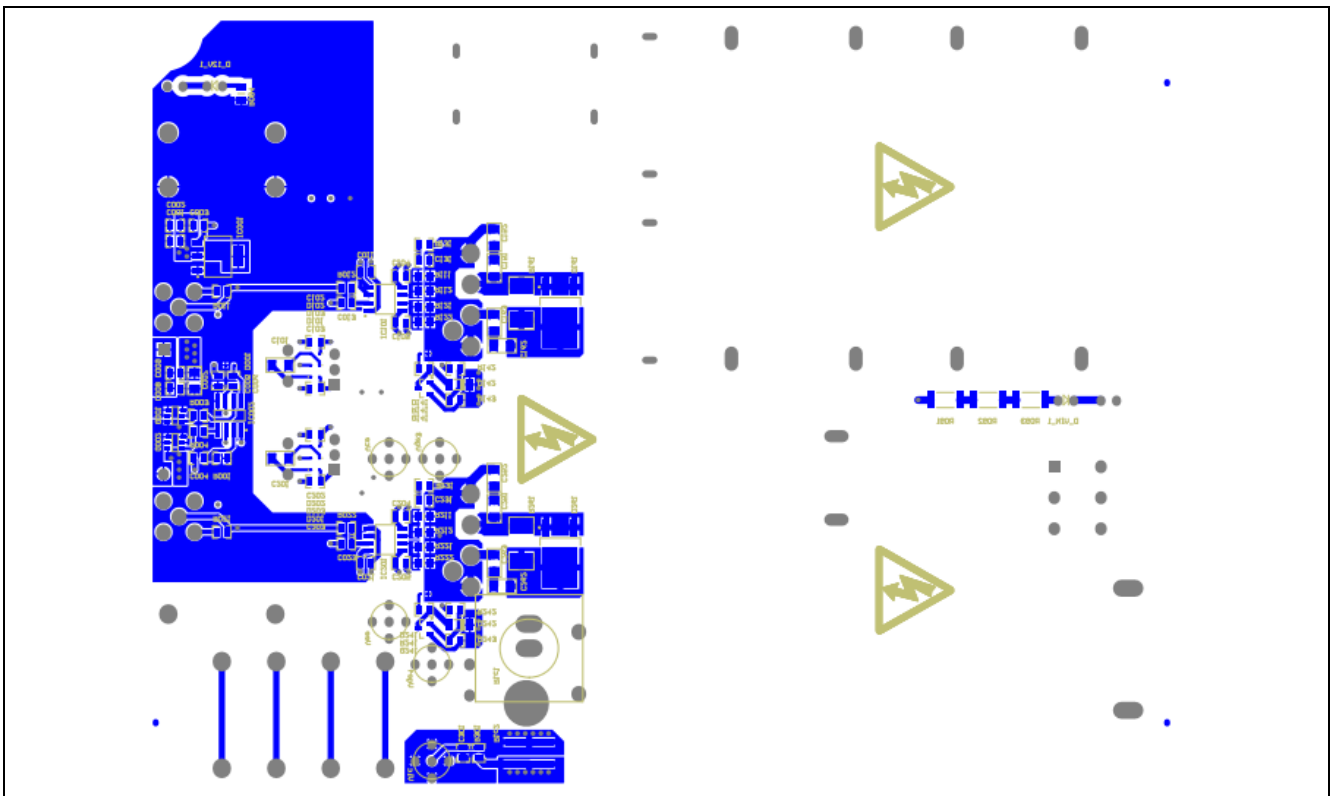

Figure 27 Bottom layer



## Revision History

Major changes since the last revision

Page or Reference	Description of change
--	First Release

#### Trademarks of Infineon Technologies AG

AURIX™, C166™, CanPAK™, CIPOS™, CIPURSE™, CoolGaN™, CoolMOS™, CoolSET™, CoolSiC™, CORECONTROL™, CROSSAVE™, DAVE™, DI-POL™, DrBLADE™, EasyPIM™, EconoBRIDGE™, EconoDUAL™, EconoPACK™, EconoPIM™, EiceDRIVER™, eupec™, FCOS™, HITFET™, HybridPACK™, ISOFACE™, IsoPACK™, i-Wafer™, MIPAQ™, ModSTACK™, my-d™, NovalithIC™, OmniTune™, OPTIGA™, OptiMOS™, ORIGA™, POWERCODE™, PRIMARION™, PrimePACK™, PrimeSTACK™, PROFET™, PRO-SIL™, RASIC™, REAL3™, ReverSave™, SatRIC™, SIEGET™, SIPMOS™, SmartLEWIS™, SOLID FLASH™, SPOC™, TEMPFET™, thinQ!™, TRENCHSTOP™, TriCore™.

#### Other Trademarks

Advance Design System™ (ADS) of Agilent Technologies, AMBA™, ARM™, MULTI-ICE™, KEIL™, PRIMECELL™, REALVIEW™, THUMB™, μVision™ of ARM Limited, UK. ANSI™ of American National Standards Institute. AUTOSAR™ of AUTOSAR development partnership. Bluetooth™ of Bluetooth SIG Inc. CAT-iq™ of DECT Forum. COLOSSUS™, FirstGPS™ of Trimble Navigation Ltd. EMV™ of EMVCo, LLC (Visa Holdings Inc.). EPCOS™ of Epcos AG. FLEXGO™ of Microsoft Corporation. HYPERTERMINAL™ of Hilgraeve Incorporated. MCS™ of Intel Corp. IEC™ of Commission Electrotechnique Internationale. IrDA™ of Infrared Data Association Corporation. ISO™ of INTERNATIONAL ORGANIZATION FOR STANDARDIZATION. MATLAB™ of MathWorks, Inc. MAXIM™ of Maxim Integrated Products, Inc. MICROTEC™, NUCLEUS™ of Mentor Graphics Corporation. MIPI™ of MIPI Alliance, Inc. MIPS™ of MIPS Technologies, Inc., USA. muRata™ of MURATA MANUFACTURING CO., MICROWAVE OFFICE™ (MWO) of Applied Wave Research Inc., OmniVision™ of OmniVision Technologies, Inc. Openwave™ of Openwave Systems Inc. RED HAT™ of Red Hat, Inc. RFMD™ of RF Micro Devices, Inc. SIRIUS™ of Sirius Satellite Radio Inc. SOLARIS™ of Sun Microsystems, Inc. SPANSION™ of Spansion LLC Ltd. Symbian™ of Symbian Software Limited. TAIYO YUDEN™ of Taiyo Yuden Co. TEAKLITE™ of CEVA, Inc. TEKTRONIX™ of Tektronix Inc. TOKO™ of TOKO KABUSHIKI KAISHA TA. UNIX™ of X/Open Company Limited. VERILOG™, PALLADIUM™ of Cadence Design Systems, Inc. VLYNQ™ of Texas Instruments Incorporated. VXWORKS™, WIND RIVER™ of WIND RIVER SYSTEMS, INC. ZETEX™ of Diodes Zetex Limited.

Last Trademarks Update 2014-07-17

[www.infineon.com](http://www.infineon.com)

**Edition 2015-04-13**

**Published by**

**Infineon Technologies AG**

**81726 Munich, Germany**

**© 2015 Infineon Technologies AG.**

**All Rights Reserved.**

**Do you have a question about any aspect of this document?**

**Email: [erratum@infineon.com](mailto:erratum@infineon.com)**

#### Legal Disclaimer

THE INFORMATION GIVEN IN THIS APPLICATION NOTE (INCLUDING BUT NOT LIMITED TO CONTENTS OF REFERENCED WEBSITES) IS GIVEN AS A HINT FOR THE IMPLEMENTATION OF THE INFINEON TECHNOLOGIES COMPONENT ONLY AND SHALL NOT BE REGARDED AS ANY DESCRIPTION OR WARRANTY OF A CERTAIN FUNCTIONALITY, CONDITION OR QUALITY OF THE INFINEON TECHNOLOGIES COMPONENT. THE RECIPIENT OF THIS APPLICATION NOTE MUST VERIFY ANY FUNCTION DESCRIBED HEREIN IN THE REAL APPLICATION. INFINEON TECHNOLOGIES HEREBY DISCLAIMS ANY AND ALL WARRANTIES AND LIABILITIES OF ANY KIND (INCLUDING WITHOUT LIMITATION WARRANTIES OF NON-INFRINGEMENT OF INTELLECTUAL PROPERTY RIGHTS OF ANY THIRD PARTY) WITH RESPECT TO ANY AND ALL INFORMATION GIVEN IN THIS APPLICATION NOTE.

#### Information

For further information on technology, delivery terms and conditions and prices, please contact the nearest Infineon Technologies Office ([www.infineon.com](http://www.infineon.com)).

#### Warnings

Due to technical requirements, components may contain dangerous substances. For information on the types in question, please contact the nearest Infineon Technologies Office. Infineon Technologies components may be used in life-support devices or systems only with the express written approval of Infineon Technologies, if a failure of such components can reasonably be expected to cause the failure of that life-support device or system or to affect the safety or effectiveness of that device or system. Life support devices or systems are intended to be implanted in the human body or to support and/or maintain and sustain and/or protect human life. If they fail, it is reasonable to assume that the health of the user or other persons may be endangered.

Компания «Океан Электроники» предлагает заключение долгосрочных отношений при поставках импортных электронных компонентов на взаимовыгодных условиях!

Наши преимущества:

- Поставка оригинальных импортных электронных компонентов напрямую с производств Америки, Европы и Азии, а так же с крупнейших складов мира;
- Широкая линейка поставок активных и пассивных импортных электронных компонентов (более 30 млн. наименований);
- Поставка сложных, дефицитных, либо снятых с производства позиций;
- Оперативные сроки поставки под заказ (от 5 рабочих дней);
- Экспресс доставка в любую точку России;
- Помощь Конструкторского Отдела и консультации квалифицированных инженеров;
- Техническая поддержка проекта, помощь в подборе аналогов, поставка прототипов;
- Поставка электронных компонентов под контролем ВП;
- Система менеджмента качества сертифицирована по Международному стандарту ISO 9001;
- При необходимости вся продукция военного и аэрокосмического назначения проходит испытания и сертификацию в лаборатории (по согласованию с заказчиком);
- Поставка специализированных компонентов военного и аэрокосмического уровня качества (Xilinx, Altera, Analog Devices, Intersil, Interpoint, Microsemi, Actel, Aeroflex, Peregrine, VPT, Syfer, Eurofarad, Texas Instruments, MS Kennedy, Miteq, Cobham, E2V, MA-COM, Hittite, Mini-Circuits, General Dynamics и др.);

Компания «Океан Электроники» является официальным дистрибьютором и эксклюзивным представителем в России одного из крупнейших производителей разъемов военного и аэрокосмического назначения «JONHON», а так же официальным дистрибьютором и эксклюзивным представителем в России производителя высокотехнологичных и надежных решений для передачи СВЧ сигналов «FORSTAR».



## JONHON

«JONHON» (основан в 1970 г.)

Разъемы специального, военного и аэрокосмического назначения:

(Применяются в военной, авиационной, аэрокосмической, морской, железнодорожной, горно- и нефтедобывающей отраслях промышленности)

«FORSTAR» (основан в 1998 г.)

ВЧ соединители, коаксиальные кабели, кабельные сборки и микроволновые компоненты:

(Применяются в телекоммуникациях гражданского и специального назначения, в средствах связи, РЛС, а так же военной, авиационной и аэрокосмической отраслях промышленности).



Телефон: 8 (812) 309-75-97 (многоканальный)

Факс: 8 (812) 320-03-32

Электронная почта: [ocean@oceanchips.ru](mailto:ocean@oceanchips.ru)

Web: <http://oceanchips.ru/>

Адрес: 198099, г. Санкт-Петербург, ул. Калинина, д. 2, корп. 4, лит. А