

MAX30112

Optimized Pulse-Oximeter and Heart Rate AFE for Wearable Health

General Description

The MAX30112 is a complete optical pulse oximetry and heart rate detection integrated analog front-end. The MAX30112 has a high-resolution, optical readout signal-processing channel with built-in ambient light cancellation, as well as high-current LED driver DACs, to form a complete optical readout signal chain. With external LED(s) and photo diode(s), the MAX30112 offers the lowest power, highest performance heart rate detection solution for wrist applications.

The MAX30112 operates on a 1.8V main supply voltage, with a separate 3.1V to 5.25V LED driver power supply. The device supports a standard I²C compatible interface, as well as shutdown modes through the software with near-zero standby current, allowing the power rails to remain powered at all times.

Applications

- Wrist-Worn Wearable Devices
- In-Ear Wearable Devices
- SpO₂ Monitoring Devices
- Fitness Wearable Devices

Benefits and Features

- Reflective or Transmissive Heart Rate, Heart Rate Variability, or SpO₂ Monitoring
- Transmit Section
 - Two 8-bit LED Current DACs
 - Four Current Ranges 50mA, 100mA, 150mA, 200mA
 - Low Noise Current Sources for High Peak Transmit to Receive Dynamic Range
 - Low 160mV Dropout to Support Direct Drive From Rechargeable Li Battery
 - High Output Impedance and High Supply Rejection to Support Unregulated Supply or Direct Drive From Boost Switcher Supply

- Receive Section
 - 19-bit Optical ADC Path to Support the Lowest Perfusion Situations
 - Low 25pA-RMS Input Referred Noise to Minimize LED Power Under Most Conditions
 - High Ambient Light Input Range of 200μA and to Support Extraction of HRM Signal in the Most Adverse Lighting Conditions
 - Built-in Front And Back End Ambient Light Cancellation, Improving Rejection and Eliminating System Complexity of Dealing with Ambient Light
 - Short Exposure Pulse Widths of 52μs, 104μs, 206μs, 417μs for Efficient Uses of LED Light
 - Multiple Sample Rate Options from 20sps to 3.2ksps
- Ultra-Low-Power Operation for Mobile and Body-Wearable Device
 - Dynamic Power Down Modes to 100sps for Low-Power Consumption
 - Full AFE Power Consumption of Less Than 25μA (typ) at 25sps
 - Large 32 Sample FIFO to Support Batch Processing in the Microcontroller
 - Variety of System Monitors Mappable to Interrupts to Off-Load System Monitoring Functions From the Microcontroller
 - Low Shutdown Current = 1.4μA (typ)
- I²C interface
- Supports a Single 1.8V Supply with Separate 3.1V to 5.25V LED Supply
- Miniature 2.8mm x 2.0mm, 6x4, 0.4mm Ball Pitch WLP Package
- -40°C to +85°C Operating Temperature Range

[Ordering Information](#) appears at end of data sheet.

Simplified Block Diagram

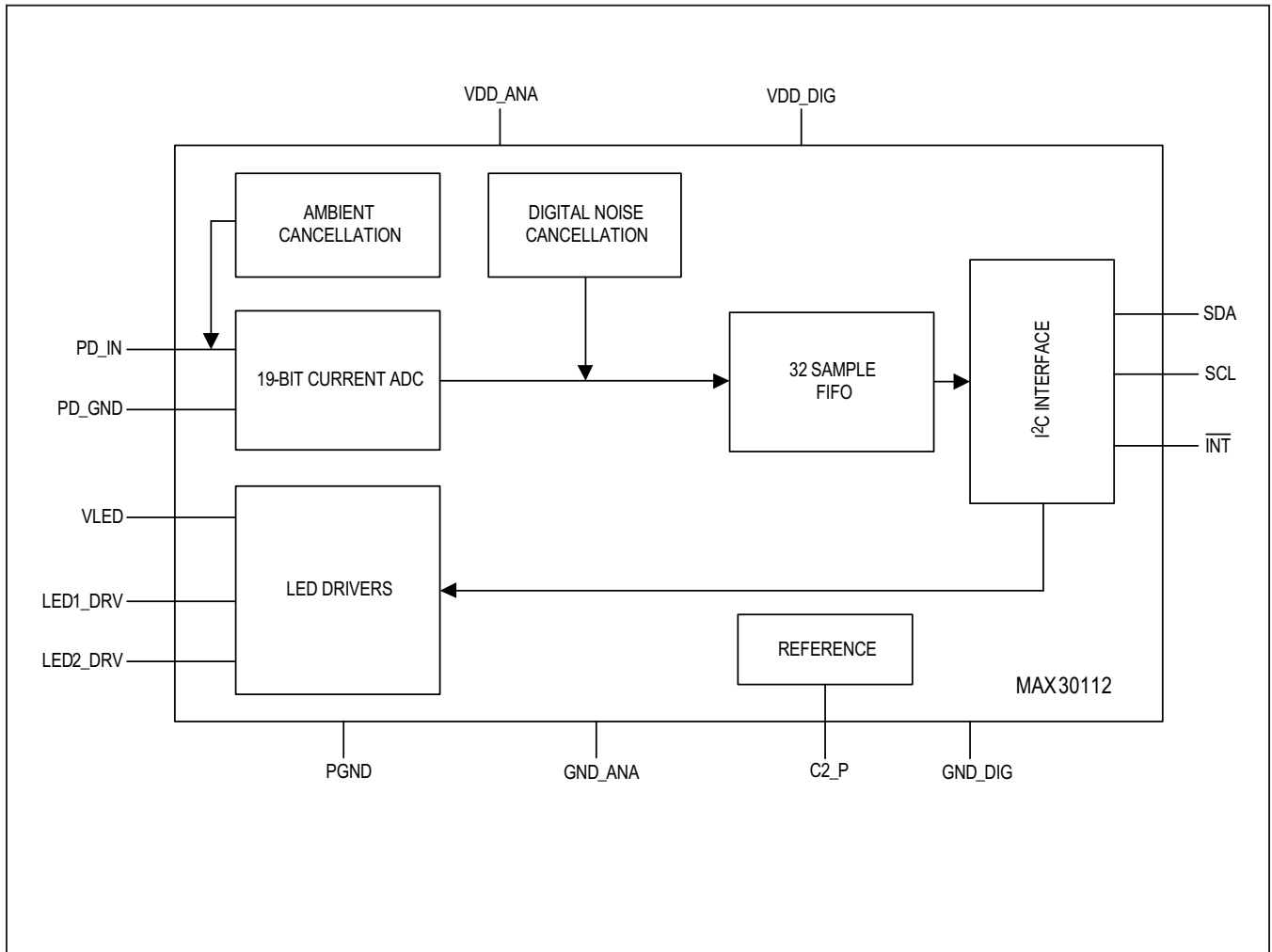

Absolute Maximum Ratings

VDD_ANA to GND_ANA	-0.3V to +2.2V	All other pins to GND_ANA	-0.3V to +2.2V
VDD_DIG to GND_ANA	-0.3V to +2.2V	Output Short-Circuit Duration	Continuous
VDD_ANA to VDD_DIG	-0.3V to +0.3V	Continuous Input Current Into Any Pin	
PGND to GND_ANA	-0.3V to +0.3V	(except LEDx_DRV Pins)	±20mA
GND_DIG to GND_ANA	-0.3V to +0.3V	Continuous Power Dissipation, WLP	
VLED to PGND	-0.3V to +6.0V	(T _A = +70°C, derate 5.5mW/°C above +70°C)	440mW
LED1_DRV to PGND	-0.3V to V _{LED} + 0.3V	Operating Temperature Range	-40°C to +85°C
LED2_DRV to PGND	-0.3V to V _{LED} + 0.3V	Storage Temperature Range	-40°C to +105°C
PD_GND to GND_ANA	Internally Shorted	Soldering Temperature (reflow)	+260°C
SDA, SCL, I ^{NT} to GND_ANA	-0.3V to +6.0V		

Stresses beyond those listed under “Absolute Maximum Ratings” may cause permanent damage to the device. These are stress ratings only, and functional operation of the device at these or any other conditions beyond those indicated in the operational sections of the specifications is not implied. Exposure to absolute maximum rating conditions for extended periods may affect device reliability.

Package Information

24-Bump WLP

PACKAGE CODE	W241C2+1
Outline Number	21-100088
Land Pattern Number	Refer to Application Note 1891
THERMAL RESISTANCE, FOUR-LAYER BOARD:	
Junction to Ambient (θ _{JA})	49°C/W

For the latest package outline information and land patterns (footprints), go to www.maximintegrated.com/packages. Note that a “+”, “#”, or “-” in the package code indicates RoHS status only. Package drawings may show a different suffix character, but the drawing pertains to the package regardless of RoHS status.

Package thermal resistances were obtained using the method described in JEDEC specification JESD51-7, using a four-layer board. For detailed information on package thermal considerations, refer to www.maximintegrated.com/thermal-tutorial.

Electrical Characteristics

(V_{DD} = V_{DD_ANA} = V_{DD_DIG} = 1.8V, V_{LED} = 3.3V, C_{LOAD} = 10pF, T_A = T_{MIN} to T_{MAX}, unless otherwise noted. Typical values are at T_A = +25°C.) (Note 1))

PARAMETER	SYMBOL	CONDITIONS		MIN	TYP	MAX	UNITS
POWER SUPPLY							
Power Supply Voltage	V _{DD}	Guaranteed by V _{DD} DC PSR		1.7	1.8	2.0	V
LED Supply Voltage	V _{LED}	Guaranteed by V _{LED} DC PSR		3.1	3.3	5.25	V
V _{DD} Supply Current	I _{DD}	Low Power = Off, LED1 or LED2 (FD1 = 0x01 or FD1 = 0x02, PPG_TINT = 0x0, LP_MODE = 0x0), Note 2	Sample Rate = 100sps, single pulse (PPG_SR = 0x4)		241	308	μA
		Low Power = On, LED1 or LED2 (FD1 = 0x01 or FD1 = 0x02, PPG_TINT = 0x0, LP_MODE = 0x1), Note 2	Sample Rate = 100sps, single pulse (PPG_SR = 0x4)		72		
			Sample Rate = 50sps, single pulse (PPG_SR = 0x2)		40		
			Sample Rate = 25sps, single pulse (PPG_SR = 0x1)		24	43	
			Sample Rate = 50sps, dual pulse (PPG_SR = 0xD)		94		
	I _{DD}		Sample Rate = 25sps, dual pulse (PPG_SR = 0xC)		51		μA

Electrical Characteristics (continued)

(V_{DD} = VDD_ANA = VDD_DIG = 1.8V, V_{LED} = 3.3V, C_{LOAD} = 10pF, T_A = T_{MIN} to T_{MAX}, unless otherwise noted. Typical values are at T_A = +25°C.) (Note 1))

PARAMETER	SYMBOL	CONDITIONS		MIN	TYP	MAX	UNITS
V _{LED} Supply Current	I _{LED}	Low Power = On, LED1 or LED2, LED driver 0mA (FD1 = 0x01 or FD1 = 0x02, PPG_TINT = 0x0, LP_MODE = 0x1, LEDx_DRV = 0x00)	Sample Rate = 100sps, single pulse (PPG_SR = 0x4)		0.1	±1	μA
		Low Power = On, LED1 or LED2, LED driver full scale (FD1 = 0x01 or FD1 = 0x02, PPG_TINT = 0x0, LP_MODE = 0x1, LEDx_DRV = 0xFF)	Sample Rate = 100sps, single pulse (PPG_SR = 0x4)		308		
			Sample Rate = 50sps, single pulse (PPG_SR = 0x2)		155		
			Sample Rate = 25sps, single pulse (PPG_SR = 0x1)		74	110	
V _{LED} Supply Current	I _{LED}	Low Power = On, LED1 and LED2, LED driver full scale (FD1 = 0x1, FD2 = 0x2, FD3 = 0x0, PPG_TINT = 0x0, LP_MODE = 0x1, LEDx_DRV = 0xFF)	Sample Rate = 100sps, single pulse (PPG_SR = 0x4)		616		μA
			Sample Rate = 50sps, single pulse (PPG_SR = 0x2)		304		
			Sample Rate = 25sps, single pulse (PPG_SR = 0x1)		149		
V _{DD} Current in Shutdown		T _A = +25°C, Note 2			1.6	5	μA
V _{LED} Current in Shutdown		T _A = +25°C				1	μA
V _{DD} Undervoltage Interrupt Threshold		T _A = +25°C			1.64		V
V _{DD} Overvoltage Interrupt Threshold		T _A = +25°C			2.0		V
OPTICAL RECEIVE CHANNEL							
ADC Resolution					19		bits
ADC Full-Scale Input Current		PPG_ADC_RGE = 0x0			6.0		μA
ADC Full-Scale Input Current (Including DC Offset DAC)		PPG_ADC_RGE = 0x1			12.0		μA
		PPG_ADC_RGE = 0x2			24.0		
		PPG_ADC_RGE = 0x3			48.0		
ADC Integration Time	t _{PPG_TINT}	LED_SETLNG = 0x3	PPG_TINT = 0x0		52		μs
			PPG_TINT = 0x1		104		
			PPG_TINT = 0x2		208		
			PPG_TINT = 0x3		417		

Electrical Characteristics (continued)

(V_{DD} = VDD_ANA = VDD_DIG = 1.8V, V_{LED} = 3.3V, C_{LOAD} = 10pF, T_A = T_{MIN} to T_{MAX}, unless otherwise noted. Typical values are at T_A = +25°C.) (Note 1))

PARAMETER	SYMBOL	CONDITIONS		MIN	TYP	MAX	UNITS
Minimum PPG Sample Rate		PPG_SR = 0x0			20		sps
Maximum PPG Sample Rate		PPG_SR = 0xA			3200		sps
Sample Rate Error		From nominal as indicated in the PPG_SR table		-2		+2	%
DC Ambient Light Input Range	ALR	T _A = +25°C			200		μA
Total Integrated Input Referred Noise Current		PPG_ADC_RGE = 0x0, T _A = +25°C	PPG_TINT = 0x0		71		pArms
			PPG_TINT = 0x1		50		
			PPG_TINT = 0x2		35		
			PPG_TINT = 0x3		25		pArms
Maximum Photodiode Input Capacitance					1000		pF
Transmit and Receive Channel V _{DD} DC PSR		Loopback test, exposure current = 1.6μA nominal, PPG_TINT = 0x3, V _{LED} = 3.3V, V _{DD} = 1.7V to 2.0V	PPG_ADC_RGE = 0x0		2420		LSB/V
			PPG_ADC_RGE = 0x1		2010		
			PPG_ADC_RGE = 0x2		1790		
			PPG_ADC_RGE = 0x3		1664		
LED TRANSMIT DRIVER							
LED Current Resolution					8		Bits
Driver DNL					1		LSB
Driver INL					1		LSB
Full-Scale LED Current	I _{LED}	LEDx_PA = 0xFF	LEDx_RGE = 0x0	45	50	55	mA
			LEDx_RGE = 0x1		100		
			LEDx_RGE = 0x2		150		
			LEDx_PA = 0xF2, LEDx_RGE = 0x3		190		
	I _{LED}	LEDx_PA = 0xFF, LEDx_RGE = 0x3 (Note 3)			200		mA
Minimum Output Voltage		LEDx_PA = 0xFF, V _{DD} = 1.8V, V _{LED} = 3.3V, 95% of the desired LED current	LEDx_RGE = 0x0		0.16	0.25	V
			LEDx_RGE = 0x1		0.32		
			LEDx_RGE = 0x2		0.49		
				LEDx_RGE = 0x3 LEDx_PA = 0xF2, V _{DD} = 1.8V, V _{LED} = 3.3V, 95% of the desired LED current		0.64	

Electrical Characteristics (continued)

($V_{DD} = V_{DD_ANA} = V_{DD_DIG} = 1.8V$, $V_{LED} = 3.3V$, $C_{LOAD} = 10pF$, $T_A = T_{MIN}$ to T_{MAX} , unless otherwise noted. Typical values are at $T_A = +25^{\circ}C$.) (Note 1))

PARAMETER	SYMBOL	CONDITIONS		MIN	TYP	MAX	UNITS
Transmit Driver V_{LED} DC PSR		LEDx_PA = 0xFF, $V_{DD} = 1.8V$, V_{LEDx_DRV} = 0.9V, $V_{LED} = 3.1V$ to 5.25V	LEDx_RGE = 0x0	-0.9	-0.04	+0.9	mA/V
			LEDx_RGE = 0x1	-0.06			
			LEDx_RGE = 0x2	-0.02			
		LEDx_PA = 0xF2, V_{DD} = 1.8V, V_{LEDx_DRV} = 0.9V, $V_{LED} = 3.1V$ to 5.25V	LEDx_RGE = 0x3	-0.025			
Transmit Driver V_{DD} DC PSR		LEDx_PA = 0xFF, V_{LED} = 3.3V, V_{LEDx_DRV} = 0.9V, $V_{DD} = 1.7V$ to 2.0V	LEDx_RGE = 0x0	-4	± 0.08	+4	mA/V
			LEDx_RGE = 0x1	0.014			
			LEDx_RGE = 0x2	0.16			μ A/V
			LEDx_PA = 0xF2, V_{LED} = 3.3V, V_{LEDx_DRV} = 0.9V, $V_{DD} = 1.7V$ to 2.0V	LEDx_RGE = 0x3	0.02		
LED Driver Compliance Interrupt	LED _{COMP}	LEDx_RGE = 0x0, LED1_DRV only		170			mV
DIGITAL / I/O CHARACTERISTICS							
Output Low Voltage	V_{OL}	SDA, \overline{INT} , $I_{SINK} = 6mA$		0.4			V
I ² C Input Voltage Low	V_{IL_I2C}	SDA, SCL		0.4			V
I ² C Input Voltage High	V_{IH_I2C}	SDA, SCL		1.4			V
Input Hysteresis	V_{HYS}	SDA, SCL		200			mV
Pin Capacitance	C_{PIN}	SDA, SCL, \overline{INT} (when inactive)		10			pF
Pin Leakage Current	I_{PIN}	SDA, SCL, \overline{INT} (when inactive), $T_A = +25^{\circ}C$		± 0.01	± 1		μ A
DIGITAL / I²C TIMING CHARACTERISTICS, NOTE 3							
I ² C Write Address				C0			Hex
I ² C Read Address				C1			Hex
Serial Clock Frequency	f_{SCL}			0	400		kHz
Bus Free Time Between STOP and START Conditions	t_{BUF}			1.3			μ s
Hold Time START and Repeat START Condition	$t_{HD,STA}$			0.6			μ s
SCL Pulse-Width Low	t_{LOW}			1.3			μ s
SCL Pulse-Width High	t_{HIGH}			0.6			μ s
Setup Time for a Repeated START Condition	$t_{SU,STA}$			0.6			μ s

Electrical Characteristics (continued)

($V_{DD} = V_{DD_ANA} = V_{DD_DIG} = 1.8V$, $V_{LED} = 3.3V$, $C_{LOAD} = 10pF$, $T_A = T_{MIN}$ to T_{MAX} , unless otherwise noted. Typical values are at $T_A = +25^{\circ}C$.) (Note 1))

PARAMETER	SYMBOL	CONDITIONS	MIN	TYP	MAX	UNITS
Data Hold Time	$t_{HD,DAT}$		0		900	ns
Data Setup Time	$t_{SU,DAT}$		100			ns
Setup Time for STOP Condition	$t_{SU,STO}$		0.6			μs
Pulse Width of Suppressed Spike	t_{SP}		0		50	ns
Bus Capacitance	CB				400	pF
SDA and SCL Receiving Rise Time	t_R		20 + 0.1CB		300	ns
SDA and SCL Receiving Fall Time	t_F		20 + 0.1CB		300	ns
SDA Transmitting Fall Time	t_{TF}		20 + 0.1CB		300	ns

Note 1: Limits are 100% tested at $T_A = +25^{\circ}C$. Limits over the operating temperature range and relevant supply voltage range are guaranteed by design and characterization.

Note 2: Limit assumes that all user-programmable memory is programmed. If user programmable memory is left unprogrammed, currents can exceed the limit shown.

Typical Operating Characteristics

VDD_ANA = VDD_DIG = 1.8V, VLED = 3.3V, GND_ANA = GND_DIG = PGND = 0V, TA = +25°C, min/max are from TA = -40°C to +85°C, unless otherwise noted. (Note 2)

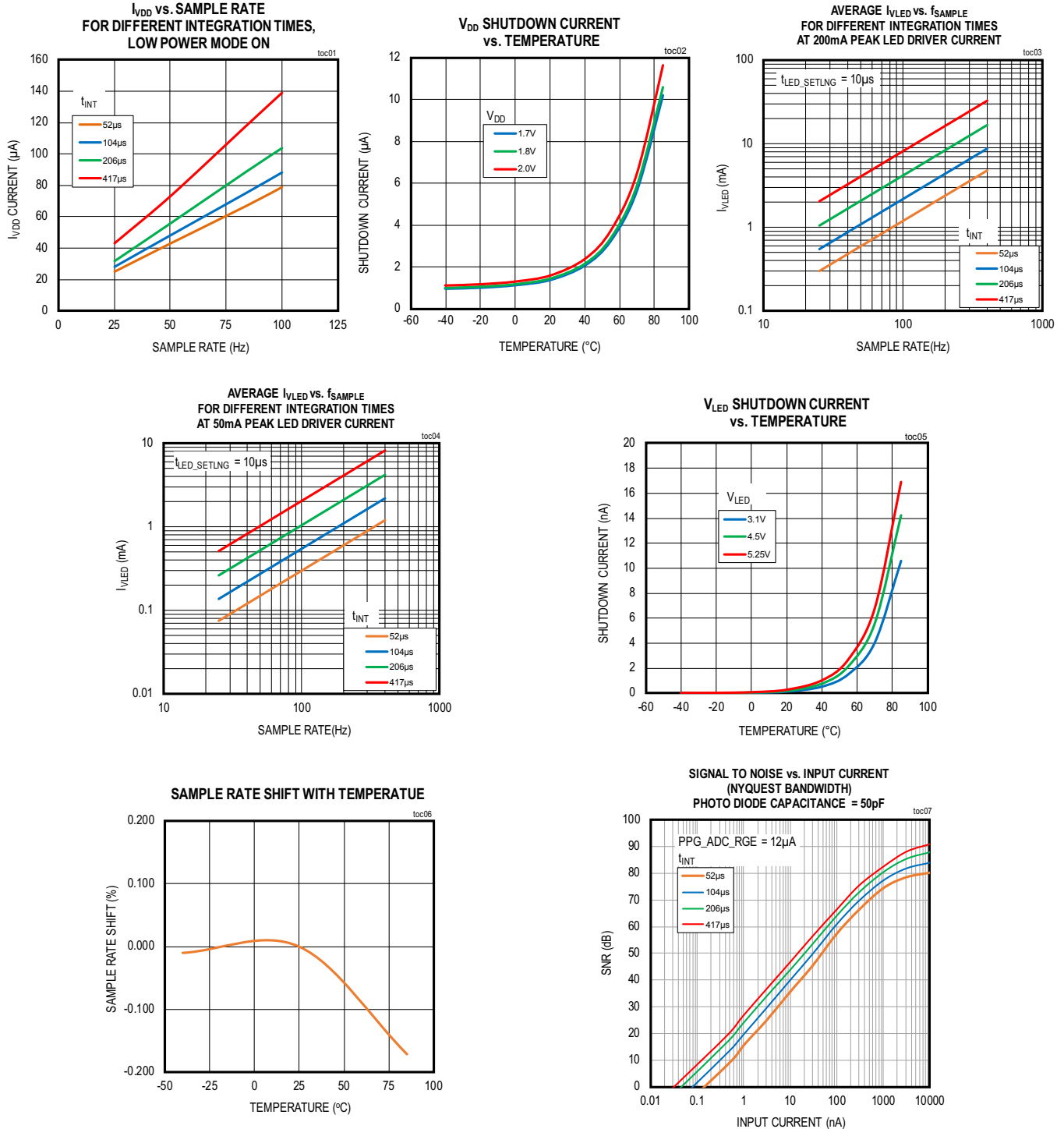

Pin Configurations

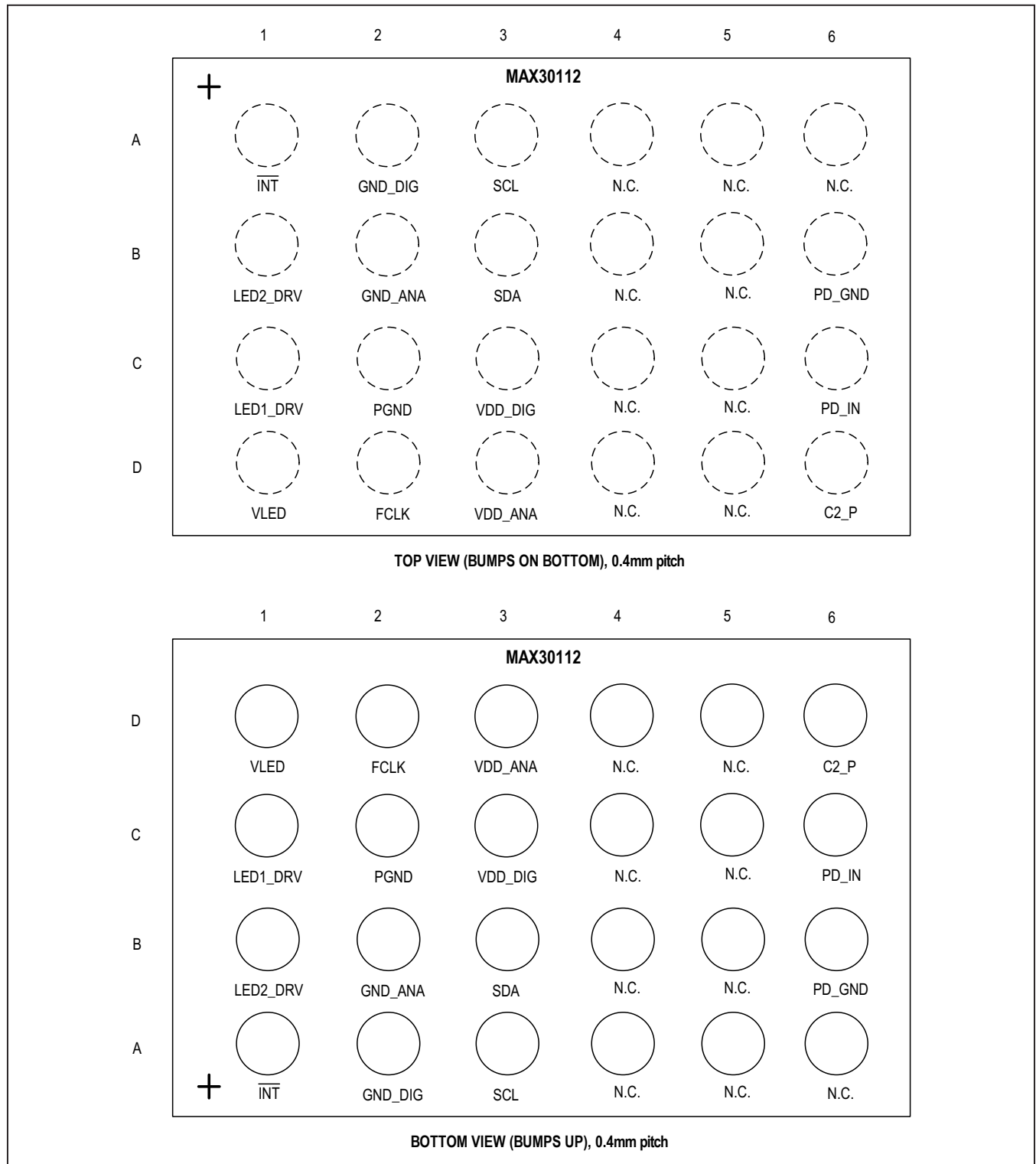

Pin Description

PIN	NAME	FUNCTION
POWER		
C3	VDD_DIG	Digital Logic Supply. Connect to externally-regulated supply. Suggest to connect to VDD_ANA.
A2	GND_DIG	Digital Logic and Digital Pad Return. Suggest to connect to common PCB ground.
D3	VDD_ANA	Analog Supply. Connect to externally-regulated supply. Bypass with a 0.1 μ F as close as possible to bump and a 10 μ F capacitor to GND_ANA.
B2	GND_ANA	Analog Power Return. Suggest to connect to common PCB ground.
D1	V_LED	LED Power Supply Input. Connect to external voltage supply. Bypass with a 10 μ F capacitor to PGND.
C2	PGND	LED Power Return.
CLOCK		
D2	FCLK	Optional External Clock input. Leave FCLK unconnected/floating, if external clock is not used.
I²C CONTROL INTERFACE		
A3	SCL	SCL Input. I ² C clock input
B3	SDA	SDA Input/Output. I ² C data I/O
A1	$\overline{\text{INT}}$	Interrupt. Programmable Open-Drain Interrupt output signal pin (Active Low)
OPTICAL		
C6	PD_IN	Photodiode Cathode Input. Keep traces as short as possible, shield with PD_GND.
B6	PD_GND	Photodiode Anode. Connect to PCB GND plane only at PD_GND pin. Use as shield trace for PD_IN.
C1	LED_DRV1	LED Driver Output 1. Connect the LED cathode to LED_DRV1 output and its anode to the V_LED supply.
B1	LED_DRV2	LED Driver Output 2. Connect the LED cathode to LED_DRV2 output and its anode to the V_LED supply.
REFERENCE		
D6	C2_P	Internal Reference Decoupling Point. Bypass with a 10 μ F capacitor to GND_ANA
N.C.		
A4, A5, A6, B4, B5, C4, C5, D4, D5	N.C.	No Connection. Internally connected, leave N.C. unconnected.

Detailed Description

The MAX30112 is a complete optical pulse oximetry and heart rate detection integrated analog front-end readout circuit designed for the demanding requirements of mobile and wearable devices. Minimal external hardware components are necessary for integration into a mobile device. The MAX30112 is fully adjustable through software registers, with the digital output data being stored in a 32-samples FIFO within the IC.

Optical Subsystem

The optical subsystem in MAX30112 is composed of ambient light cancellation (ALC), a continuous-time, sigma-delta ADC, and proprietary discrete time filter. ALC incorporates a proprietary scheme to cancel ambient-light-generated photo diode current up to 200 μ A, allowing the sensor to work in high ambient light conditions. The ADC has programmable full-scale ranges of between 6 μ A and 48 μ A. The internal ADC is a continuous-time oversampling sigma-delta converter with 19-bit resolution. The ADC output data rate can be programmed from 20sps (samples per second) to 3200sps. The MAX30112 includes a proprietary discrete time filter to reject 50Hz/60Hz interference and changing residual ambient light from the sensor measurements.

MAX30112 supports Dynamic Power Down mode (Low Power mode) in which the power consumption is decreased between samples. This mode is only supported for sample rates 100sps and below. For more details on the power consumption at each sample rates, refer to the [Electrical Characteristics](#) table.

LED Driver

The MAX30112 integrates two precision LED-driver-current DACs that modulate LED pulses for both SpO₂ and HR measurements. The LED current DACs have 8-bits of dynamic range with four programmable full-scale ranges of 50mA, 100mA, 150mA, and 200mA. The LED drivers are low-dropout current sources, allowing for

low-noise, power-supply independent LED currents to be sourced at the lowest supply voltage possible; thus minimizing LED power consumption. The LED pulse width and the LED settling time can be programmed to allow the algorithms to optimize SpO₂ and HR accuracy at the lowest dynamic power consumption dictated by the application.

I²C/SMBus Compatible Serial Interface

The MAX30112 features an I²C/SMBus™ compatible, 2-wire serial interface consisting of a serial data line (SDA) and a serial clock line (SCL). SDA and SCL facilitate communication between the MAX30112 and the master at clock rates up to 400kHz.

Figure 1 shows the 2-wire interface timing diagram. The master generates SCL and initiates data transfer on the bus. The master device writes data to the MAX30112 by transmitting the proper slave address followed by the register address and then the data word. Each transmit sequence is framed by a START (S) or REPEATED START (Sr) condition and a STOP (P) condition. Each word transmitted to the MAX30112 is 8-bits long and is followed by an acknowledge clock pulse. A master reading data from the MAX30112 transmits the proper slave address followed by a series of nine SCL pulses. The MAX30112 transmits data on SDA in sync with the master-generated SCL pulses. The master acknowledges receipt of each byte of data. Each read sequence is framed by a START (S) or REPEATED START (Sr) condition, a not acknowledge, and a STOP (P) condition. SDA operates as both an input and an open-drain output. A pullup resistor is required on SDA. SCL operates only as an input. A pullup resistor is required on SCL if there are multiple masters on the bus, or if the single master has an open-drain SCL output. Series resistors in line with SDA and SCL are optional. Series resistors protect the digital inputs of the MAX30112 from high voltage spikes on the bus lines, and minimize crosstalk and undershoot of the bus signals.

Detailed I²C Timing Diagram

The detailed timing diagram of various electrical characteristics is shown in [Figure 1](#).

Bit Transfer

One data bit is transferred during each SCL cycle. The data on SDA must remain stable during the high period of the SCL pulse. Changes in SDA while SCL is high are control signals (see the [START and STOP Conditions](#) section).

START and STOP Conditions

SDA and SCL idle high when the bus is not in use. A master initiates communication by issuing a START condition. A START condition is a high-to-low transition on SDA with SCL high. A STOP condition is a low-to-high transition on SDA while SCL is high ([Figure 2](#)). A START condition from the master signals the beginning of a transmission to the MAX30112. The master terminates transmission, and frees the bus, by issuing a STOP condition. The bus remains active if a REPEATED START condition is generated instead of a STOP condition.

Early STOP Conditions

The MAX30112 recognizes a STOP condition at any point during data transmission unless the STOP condition occurs in the same high pulse as a START condition. For proper operation, do not send a STOP condition during the same SCL high pulse as the START condition.

Slave Address

The slave address is defined as the seven most significant bits (MSBs), followed by the read/write bit. For the MAX30112, the seven most significant bits are 0b1100000. For read mode, set the read/write bit to 1 (slave address = 0xC1). For write mode, set the read/write bit to 0 (slave address = 0xC0). The address is the first byte of information sent to the IC after the START condition.

Acknowledge Bit

The acknowledge bit (ACK) is a clocked 9th bit that the MAX30112 uses to handshake receipt each byte of data when in write mode ([Figure 3](#)). The MAX30112 pulls down SDA during the entire master-generated 9th clock pulse if the previous byte is successfully received. Monitoring ACK allows for detection of unsuccessful data transfers. An unsuccessful data transfer occurs if a receiving device is busy or if a system fault has occurred. In the event of an unsuccessful data transfer, the bus master will retry communication. The master pulls down SDA during the 9th clock cycle to acknowledge receipt of data when the MAX30112 is in read mode. An acknowledge is sent by the master after each read byte to allow data transfer to continue. A not-acknowledge is sent when the master reads the final byte of data from the MAX30112, followed by a STOP condition.

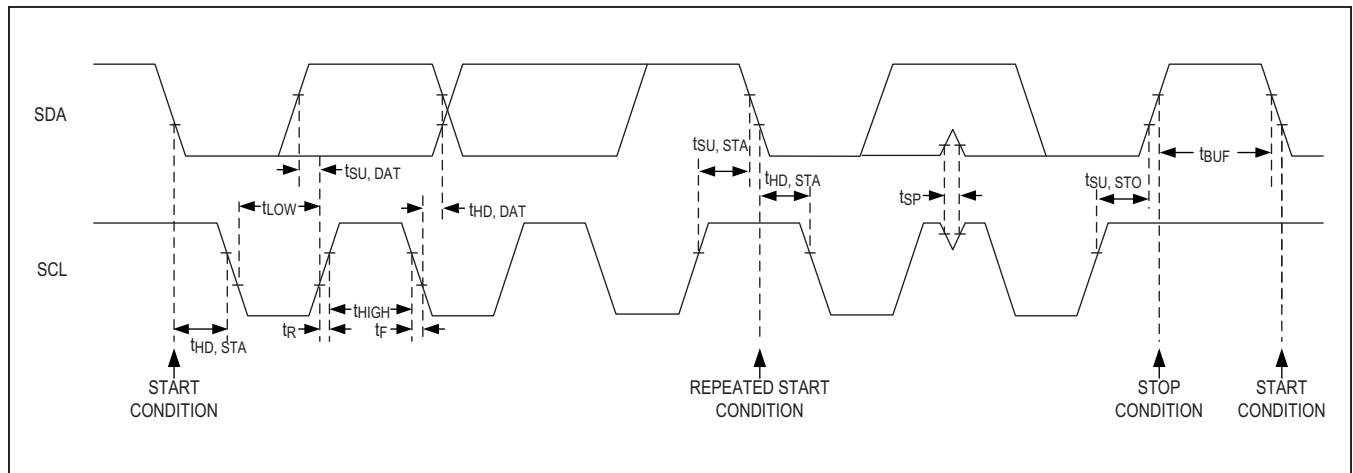

Figure 1. Detailed I²C Timing Diagram

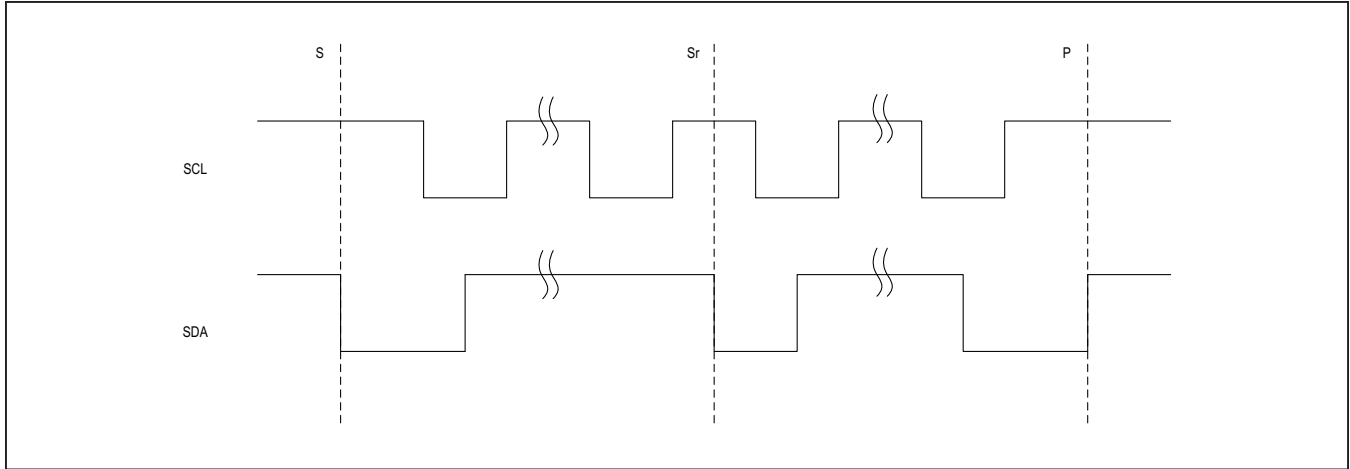

Figure 2: I²C START, STOP, and REPEATED START Condition

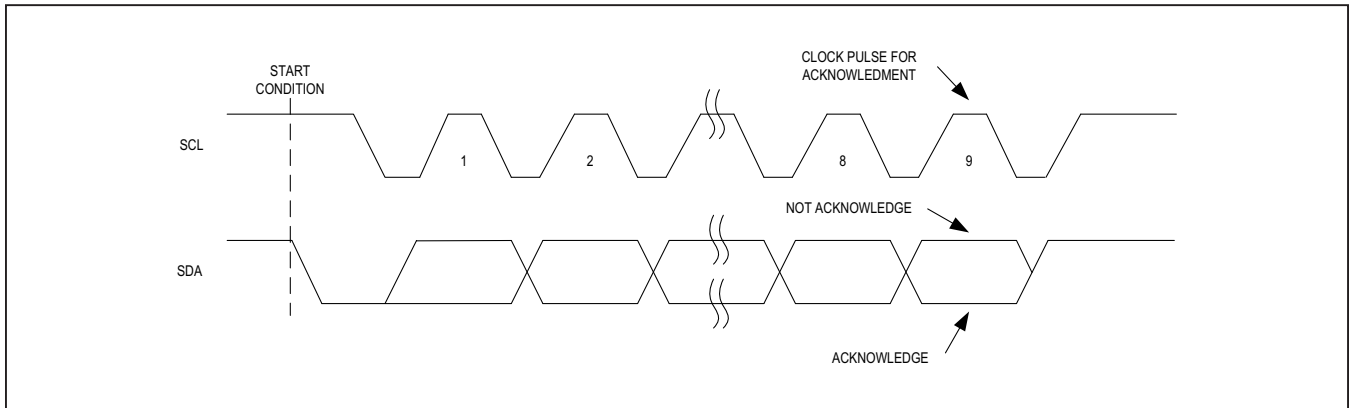

Figure 3. I²C Acknowledge Bit

I²C Write Data Format

A write to the MAX30112 includes transmission of a START condition, the slave address with the R/W bit set to 0, one byte of data to configure the internal register address pointer, one or more bytes of data, and a STOP condition.

Figure 4 illustrates the proper frame format for writing one byte of data to the MAX30112. Figure 5 illustrates the frame format for writing n-bytes of data to the MAX30112.

The slave address with the R/W bit set to 0 indicates that the master intends to write data to the MAX30112. The MAX30112 acknowledges receipt of the address byte during the master-generated 9th SCL pulse.

The second byte transmitted from the master configures the MAX30112’s internal register address pointer. The pointer tells the MAX30112 where to write the next byte of data. An acknowledge pulse is sent by the MAX30112 upon receipt of the address pointer data.

The third byte sent to the MAX30112 contains the data that will be written to the chosen register. An acknowledge pulse from the MAX30112 signals receipt of the data byte. The address pointer auto increments to the next register address after each received data byte. This auto-increment feature allows a master to write to sequential registers within one continuous frame. The master signals the end of transmission by issuing a STOP condition. The auto_increment feature is disabled when there is an attempt to write to the FIFO_DATA register.

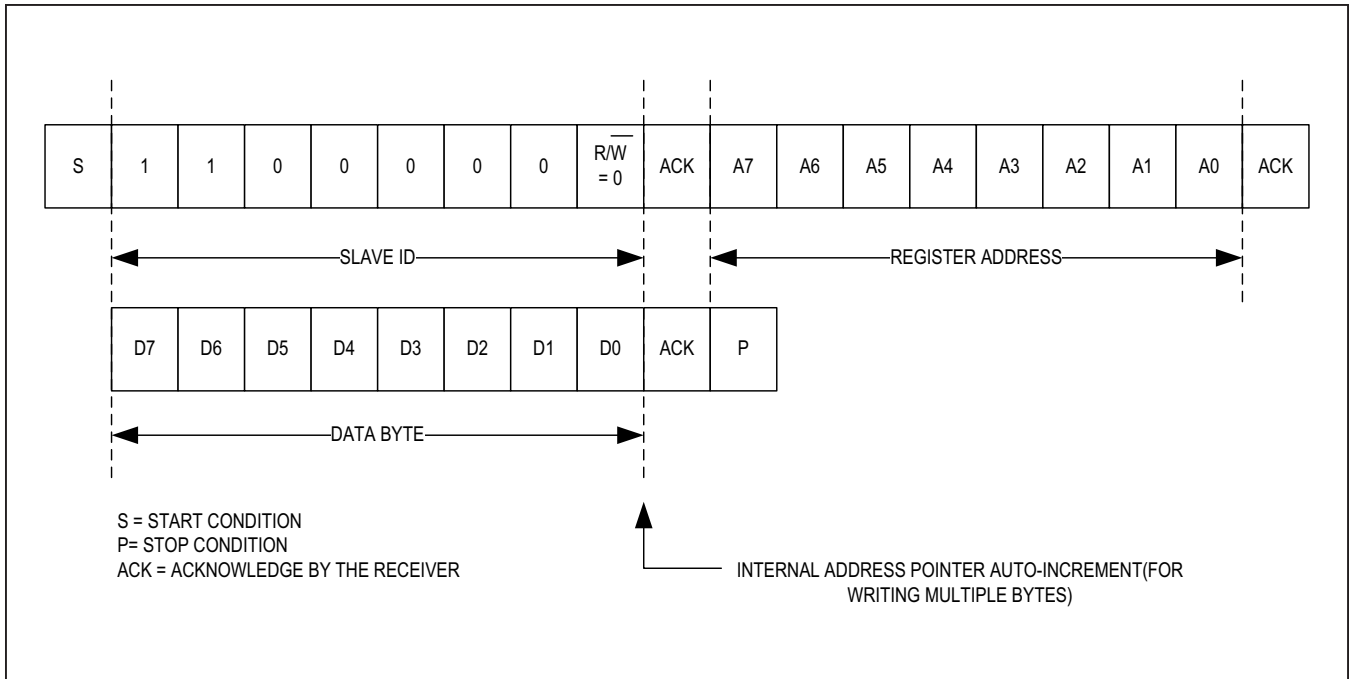

Figure 4. I²C Single-Byte Write Transaction

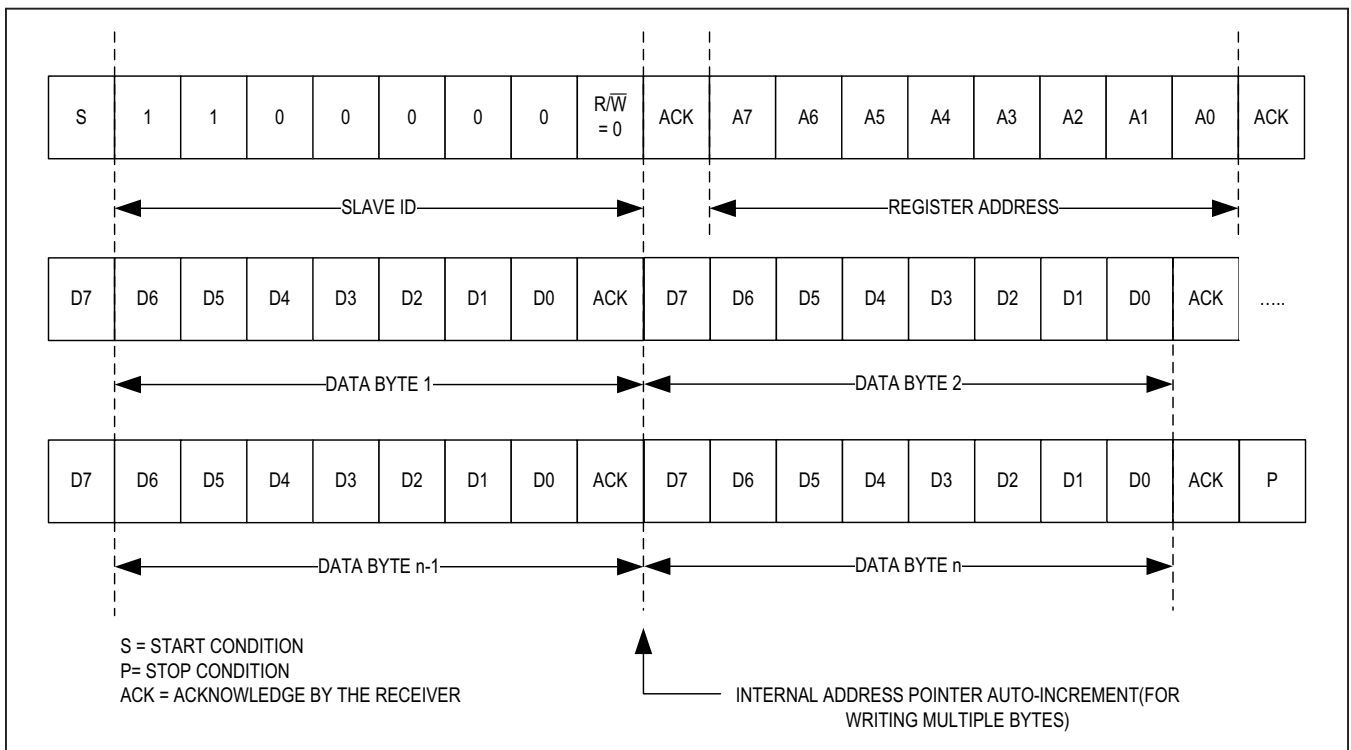

Figure 5. I²C Multi-Byte Write Transaction

I²C Read Data Format

Send the slave address with the R/W bit set to 1 to initiate a read operation. The MAX30112 acknowledges receipt of its slave address by pulling SDA low during the 9th SCL clock pulse. A START command followed by a read command resets the address pointer to register 0x00.

The first byte transmitted from the MAX30112 will be the contents of register 0x00. Transmitted data is valid on the rising edge of SCL. The address pointer auto-increments after each read data byte. This auto-increment feature allows all registers to be read sequentially within one continuous frame. The auto_increment feature is disabled when there is an attempt to read from the FIFO_DATA register. A STOP condition can be issued after any number of read data bytes. If a STOP condition is issued followed by another read operation, the first data byte to be read will be from register 0x00.

The address pointer can be preset to a specific register before a read command is issued. The master presets the address pointer by first sending the MAX30112 slave address with the R/W bit set to 0 followed by the register address. A REPEATED START condition is then sent followed by the slave address with the R/W bit set to 1. The MAX30112 then transmits the contents of the specified register. The address pointer auto-increments after transmitting the first byte.

The master acknowledges receipt of each read byte during the acknowledge clock pulse. The master must acknowledge all correctly received bytes except the last byte. The final byte must be followed by a not acknowledge from the master and then a STOP condition. [Figure 6](#) illustrates the frame format for reading one byte from the MAX30112. [Figure 7](#) illustrates the frame format for reading multiple bytes from the MAX30112.

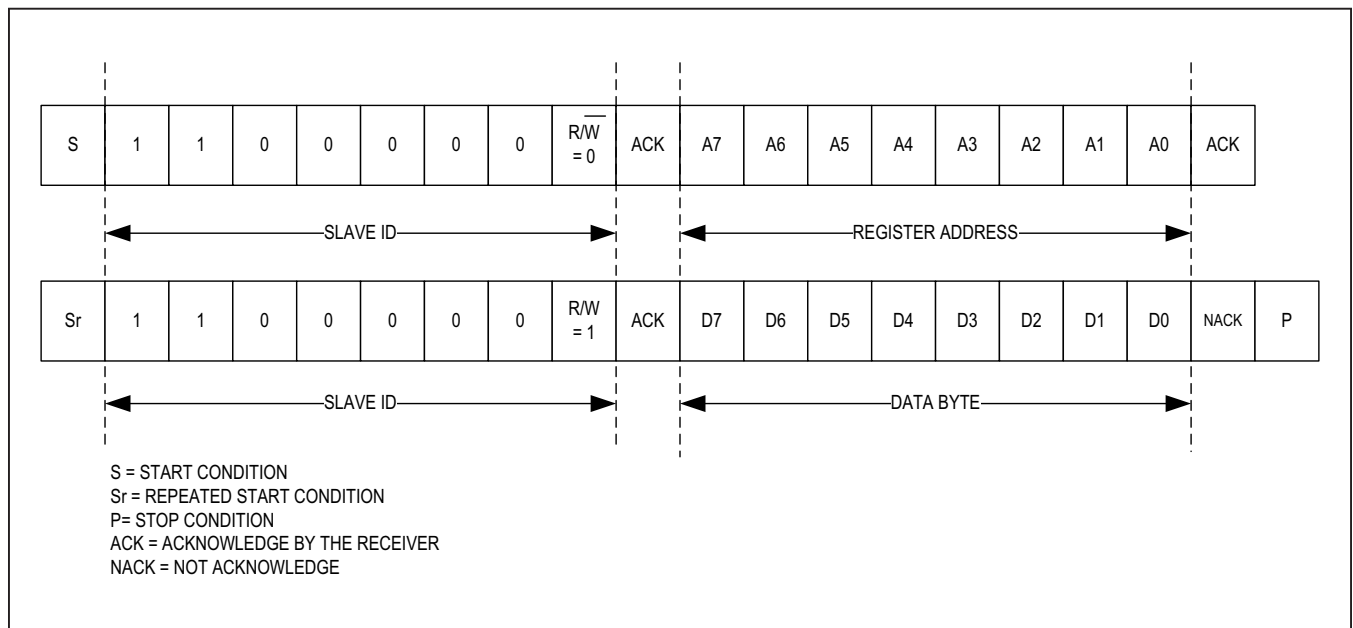

Figure 6. I²C Single-Byte Read Transaction

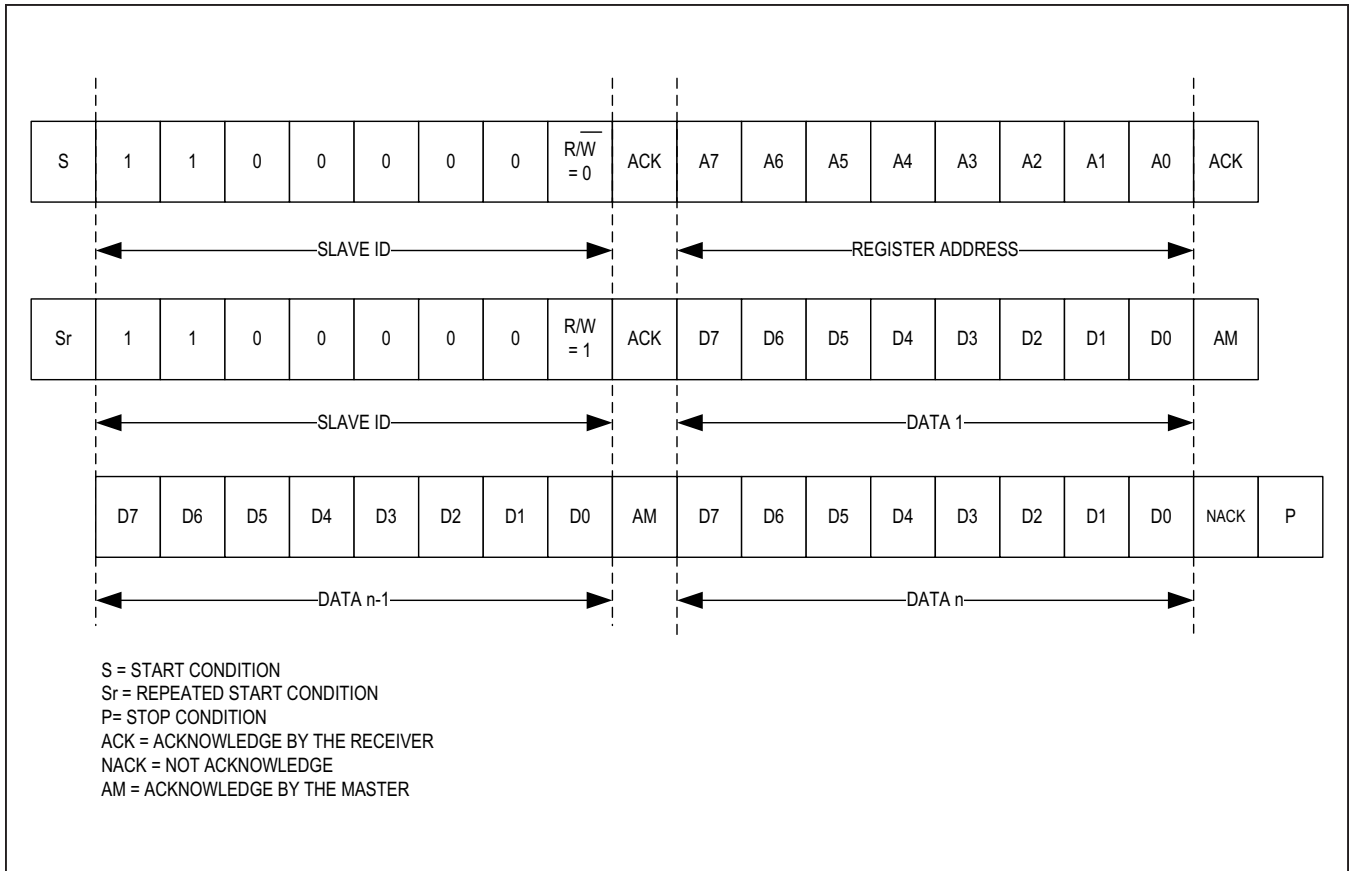

Figure 7. I²C Multi-Byte Read Transaction

FIFO Configuration

The FIFO can hold up to 32 samples of data, with each sample comprised of up to 4 data items (time slots). Each data item is 3 bytes. The content of each data item is programmed through register FD1 to FD4 (FIFO data control). These data items are ADC counts from the analog front-end of this device. The FIFO supports the following features:

- Maximum 32 samples (depth)
- Supports up to four data items in each sample
- FIFO roll-on full
- Different interrupt modes based on watermark

There are seven registers that control how the FIFO is configured and read out. These registers are illustrated below.

FIFO Data Control (Address 0x09 and 0x0A)

The data format in the FIFO, as well as the sequencing of exposures, are controlled by the FIFO Data Control registers through FD1 through FD4. There are four FIFO data items available, each holding up to 32 samples. The exposure sequence cycles through the FIFO data bit fields, starting from FD1 to FD4. The first FIFO data field set to NONE (0000) ends the sequence.

Table 1. FIFO Information, Control and Configuration Registers

ADDRESS	REGISTER NAME	DEFAULT VALUE	B7	B6	B5	B4	B3	B2	B1	B0
0X04	FIFO Write Pointer	00	-	-	-	FIFO_WR_PTR[4:0]				
0X05	Overflow Counter	00	-	-	-	OVF_COUNTER[4:0]				
0X06	FIFO Read Pointer	00	-	-	-	FIFO_RD_PTR[4:0]				
0X07	FIFO Data Register	00	FIFO_DATA[7:0]							
0X08	FIFO Configuration	0F	-	FIFO_STAT_CLR	A_FULL_TYPE	FIFO_RO	FIFO_A_FULL[3:0]			
0x09	FIFO Data Control 1	00	FD2[3:0]				FD1[3:0]			
0x0A	FIFO Data Control 2	00	FD4[3:0]				FD3[3:0]			

Table 2: Data Items Type for FIFO Control Registers

FDX[3:0]*	DATA TYPE	FIFO DATA CONTENT	NOTE
0000	NONE	-	-
0001	LED1	PPG_DATA[18:0]	MS bits should be masked
0010	LED2	PPG_DATA[18:0]	MS bits should be masked
0011	Reserved	-	-
0100	Reserved	-	-
0101	PILOT LED1	PPG_DATA[18:0]	MS bits should be masked
0110	Reserved	-	-
0111	Reserved	-	-
1000	Reserved	-	-
1001	Reserved	-	-
1010	Reserved	-	-
1011	Reserved	-	-
1100	DIRECT_AMBIENT	PPG_DATA[18:0]	MS bits should be masked
1101	LED1 and LED2	PPG_DATA[18:0]	MS bits should be masked
1110	Reserved	-	-
1111	Reserved	--	-

* Note: In FDX, x is 1, 2, 3, or 4 for the corresponding FIFO bank.

Write Pointer (Register 0X04)

FIFO_WR_PTR[4:0] points to the FIFO location where the next sample will be written. This pointer advances for each sample pushed on to the FIFO by the internal conversion process. The write pointer is a 5-bit counter and will wrap around to count 0x00 on the next sample after count 0x1F.

Overflow Counter (Register 0X05)

OVF_COUNTER[4:0] logs the number of samples lost if the FIFO is not read in a timely fashion. This counter holds at count value 0x1F. When a complete sample is popped from the FIFO (when the read pointer advances), and OVF_COUNTER is reset to zero. This counter is essentially a debug tool. It should be read immediately before reading the FIFO in order to check if an overflow condition has occurred.

Read Pointer (Register 0X06)

FIFO_RD_PTR[4:0] points to the location from where the next sample from the FIFO will be read through the interface. This advances each time a sample is read from the FIFO. The read pointer can be both read and written to. This allows a sample to be reread from the FIFO if it has not already been overwritten. The read pointer is updated from a 5-bit counter and will wrap around to count 0x00 from count 0x1F.

FIFO Data (Register 0X07)

FIFO_DATA[7:0] is a read-only register used to retrieve data from the FIFO. The format and data type of the data stored in the FIFO is determined by the FIFO data control register. Readout from the FIFO follows a progression defined by the FIFO data control register as well. This configuration is best illustrated by a few examples.

Assume it is desired to perform an SpO₂ measurement simultaneously with monitoring the ambient level on the photodiode to adjust the IR and red LED intensity. To perform this measurement, config the following registers,

FIFO Data Control field

```
FD1[3:0] = 0x1 (LED1)
FD2[3:0] = 0x2 (LED2)
FD3[3:0] = 0xC (DIRECT_AMBIENT)
FD4[3:0] = 0x0 (NONE)
```

PPG Configuration

```
PPG_ADC_RGE[1:0] (Gain Range Control)
PPG_SR[3:0]      (Sample Rate Control)
PPG_TINT[1:0]   (Integration Time)
```

LED Pulse Amplitude

```
LED1_PA[7:0] (LED1 Current Pulse Amplitude)
LED2_PA[7:0] (LED2 Current Pulse Amplitude)
```

When done, the sample sequence and the data format in the FIFO will follow the following time/location sequence.

```
LED1 sample 1
LED2 sample 1
DIRECT_AMBIENT sample 1
LED1 sample 2
LED2 sample 2
DIRECT_AMBIENT sample 2
.
.
.
LED1 sample n
LED2 sample n
DIRECT_AMBIENT sample n
```

where:

LED1 sample x = ambient light corrected photodiode ADC count exposure data from LED1 for the sample x

LED2 sample x = ambient light corrected photodiode ADC count exposure data from LED2 for the sample x

DIRECT_AMBIENT sample x = direct ambient sample x

n is the number of samples in the FIFO, which can be up to 32 samples.

For a second example, assume it is desired to pulse LED1 and LED2 simultaneously while also monitoring the ambient level. In this case, set the following registers,

FIFO Data Control field

```
FD1[3:0] = 0xD (LED1 and LED2)
FD2[3:0] = 0xC (DIRECT_AMBIENT)
FD3[3:0] = 0x0 (NONE)
FD4[3:0] = 0x0 (NONE)
```

The sequencing in the FIFO will then be,

```
LED1 and LED2 sample1
DIRECT_AMBIENT sample 1
LED1 and LED2 sample2
DIRECT_AMBIENT 2
.
.
.
LED1 and LED2 sample n
DIRECT_AMBIENT n
```

where:

LED1 and LED2 sample x = ambient light corrected photodiode ADC count exposure data when both LED1 and LED2 are active simultaneously

DIRECT_AMBIENT sample x = direct ambient corrected sample x

The number of bytes of active data samples is given by: $3 \times K \times N$,

where:

K = the number of active sampled channels as defined in the FIFO_Data_Control register 0x09 and 0x0A

N = the number of active data samples in the FIFO

The number of active data samples in the FIFO is directly readable by subtracting the FIFO_RD_PTR[4:0] from the FIFO_WR_PTR[4:0], and taking wrap around of the pointers into consideration. It is typically controlled in the system by generating an interrupt on the INT line when the FIFO reaches a watermark level computed from the FIFO_A_FULL[3:0] field in the FIFO Configuration register (0x08). In this case, when the active data samples in the FIFO reach a level given by $32 - \text{FIFO_A_FULL}[3:0]$, an A_FULL interrupt is generated.

To calculate the number of active samples when the INT signal is asserted, execute the following pseudo-code:

```
read the OVF_COUNTER register
read the FIFO_WR_PTR register
read the FIFO_RD_PTR register
if (OVF_COUNTER == 0), then // no overflow occurred
    if (FIFO_WR_PTR > FIFO_RD_PTR) then
        NUM_AVAILABLE_SAMPLES = FIFO_WR_PTR
        - FIFO_RD_PTR
    else
        NUM_AVAILABLE_SAMPLES = FIFO_WR_PTR
        + 32 - FIFO_RD_PTR
    endif
else
    NUM_AVAILABLE_SAMPLES = 32 // overflow
    occurred and data has been lost
endif
```

FIFO data format depends on the data type being stored. Optical data, whether ambient-corrected LED exposure, ambient-corrected proximity, or direct ambient-sampled data is as shown in the Table 3. The ADC data is left-justified at FIFO_DATA[18] and the MSBs (FIFO_DATA[23:18]) are don't care and should be masked as shown in Table 3. In other words, the MSB bit of the ADC data is always in the bit 18 position.

The ADC resolution is set by the PPG_LED_PW[1:0] in the PPG Configuration 1 Register. This field generates an ADC resolution of 19, 18, 17, or 16 bits and is tied to the selected integration time of 417µs, 206µs, 104µs, or 52µs, respectively. In lower ADC resolutions, the unused LSBs should be masked.

Table 3. Integration Pulse Width, Resulting ADC Resolution, and FIFO Data Format

Integration Pulse Width	ADC Res	FIFO DATA FORMAT (FIFO_DATA[23:0])																							
		ADC Value																							
		F23	F22	F21	F20	F19	F18	F17	F16	F15	F14	F13	F12	F11	F10	F9	F8	F7	F6	F5	F4	F3	F2	F1	F0
417µs	19-bits	X	X	X	X	X	018	017	016	015	014	013	012	011	010	09	08	07	06	05	04	03	02	01	00
206µs	18-bits	X	X	X	X	X	018	017	016	015	014	013	012	011	010	09	08	07	06	05	04	03	02	01	X
104µs	17-bits	X	X	X	X	X	018	017	016	015	014	013	012	011	010	09	08	07	06	05	04	03	02	X	X
52µs	16-bits	X	X	X	X	X	018	017	016	015	014	013	012	011	010	09	08	07	06	05	04	03	X	X	X

FIFO Almost Full (Watermark)

The FIFO_A_FULL[3:0] register in the FIFO_Configuration register (0x08) determines when the A_FULL bit in the Interrupt_Status 1 register (0x00) gets asserted. The FIFO is almost full when it has 32 minus FIFO_A_FULL[3:0] samples. Then, if A_FULL_EN mask bit in the Interrupt_Enable 1 register (0x02) is set, the A_FULL bit in the Interrupt_Status 1 will be set and routed to the INT pin on the MAX30112 interface. This condition prompts the Application Processor to read samples from the FIFO before it gets filled. The A_FULL bit is cleared and INT is deasserted when the status register is read, or when the FIFO_DATA register (0x07) is read and FIFO_STAT_CLR (0x08) bit is set.

When the application processor receives an interrupt, there are at least 32 minus FIFO_A_FULL[3:0] samples available in the FIFO. It is not necessary to read the FIFO_WR_PTR and FIFO_RD_PTR registers. The Application Processor may read all the available samples in the FIFO, or only a portion of it. At high sample rates, it is recommended that only a portion of the available samples are read on an A_FULL interrupt, to ensure that FIFO reading does not happen when the next sample conversion is in progress. The remaining samples will be read on the next interrupt.

If the A_FULL interrupt is not enabled, the Application Processor has to read the FIFO in polling mode. In this mode the Application Processor has to read the FIFO_WR_PTR and FIFO_RD_PTR registers to calculate the number of samples available in the FIFO, and then decide how many samples to read. However, polling mode is not recommended, because in this mode an interface transaction will inevitably overlap an optical sample, potentially adding noise to the optical data. Because of this concern, the interface transaction should occur during the dead time between optical samples to avoid adding additional noise.

FIFO_RO (FIFO Rollover)

The FIFO_RO bit in the FIFO_Configuration register (0x08) determines whether samples get pushed on to the FIFO when it is full. If push is enabled when FIFO is full, old samples are lost. If FIFO_RO is not set, the new sample is dropped and the FIFO is not updated.

A_FULL_TYPE

The A_FULL_TYPE bit defines the behavior of the A_FULL interrupt. If the A_FULL_TYPE bit is set low, the A_FULL interrupt gets asserted when the A_FULL condition is detected and cleared by status register read, but reasserts for every sample if the A_FULL condition persists.

If A_FULL_TYPE bit is set high, the A_FULL interrupt gets asserted only when the A_FULL condition is detected. The interrupt gets cleared on status register read, and does not re-assert for every sample until a new A_FULL condition is detected.

FIFO_STAT_CLR

The FIFO_STAT_CLR bit defines whether the A-FULL interrupt should get cleared by FIFO_DATA register read. If FIFO_STAT_CLR is set low, A_FULL and DATA_RDY interrupts do not get cleared by FIFO_DATA register read but get cleared by status register read. If FIFO_STAT_CLR is set high, A_FULL and DATA_RDY interrupts get cleared by a FIFO_DATA register read or a status register read.

Optical Timing

The AFE can be configured to make a variety of measurements which involves the following options:

- LED1
- LED2
- LED1 + LED2
- Direct Ambient Measurement

For more details on the available modes, refer to [FIFO Configuration](#) section.

The “LED Ambient Sample” is integrated without turning on the LED, while “LED Exposure Sample” is integrated with LED illumination driven by the on-chip LED driver. Each “LED Exposure Sample” output is then compensated by the “LED Ambient Sample” at the front-end before the ADC conversion. The final FIFO exposure value for each LED mode represents an ambient corrected LED exposure signal.

The controller is also configurable to measure direct ambient level for every exposure sample. The direct ambient measurement can be used to adjust the LED drive level to compensate for increased noise levels when high interfering ambient signals are present.

The following optical timing diagrams illustrate the possible measurement configurations.

Sequential LED1 and LED2 Pulsing with Direct Ambient Sampling

The optical timing diagram in [Figure 8](#) illustrates the optical timing when both LED1 and LED2 are enabled to pulse sequentially followed by a direct ambient measurement. This timing mode is an example of when measuring SpO₂ with IR and red LEDs. The converted values of the optical measurements made by each LED followed by the converted direct ambient value will appear successively in the FIFO.

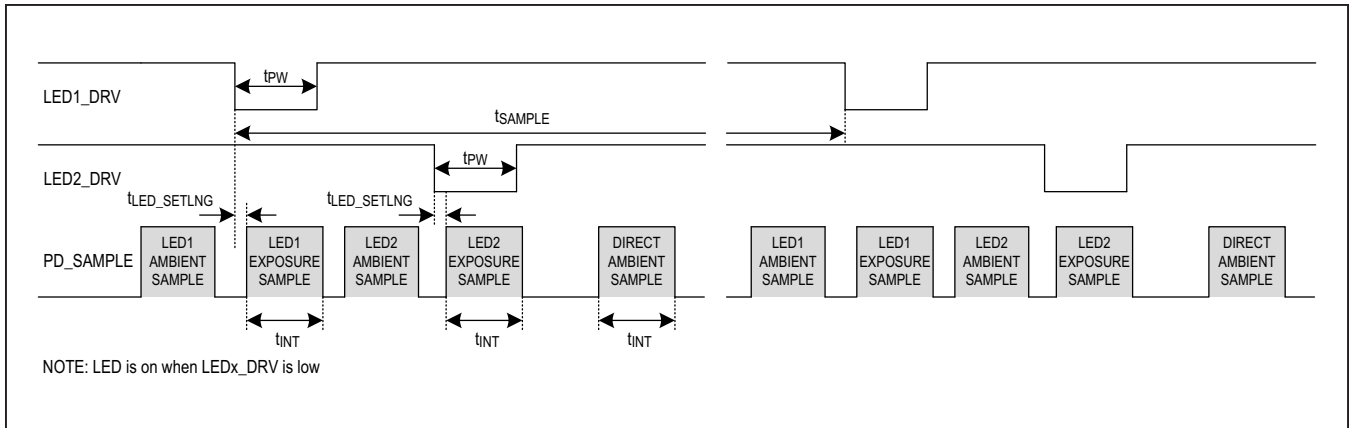

Figure 8. Timing for LED1 and LED2 Firing with Direct Ambient Sampling

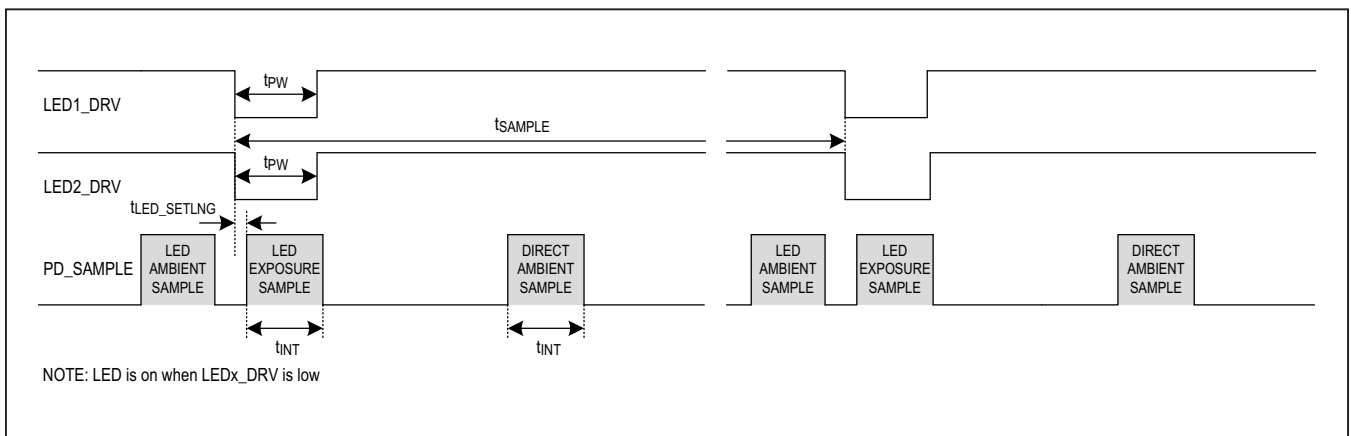

Figure 9. Timing for Dual LED Pulsing with Direct Ambient Sampling

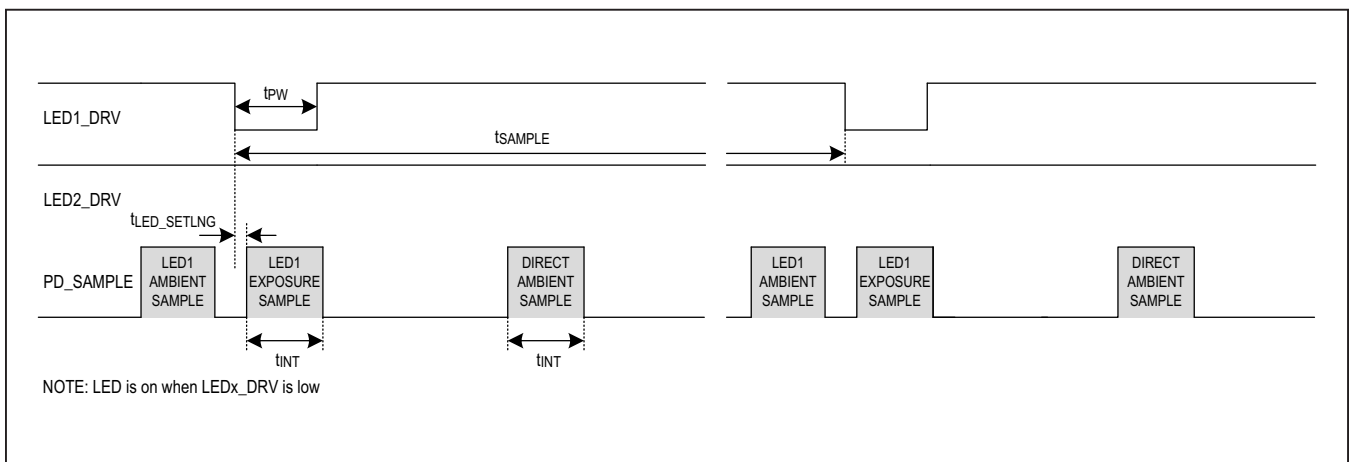

Figure 10. Timing for LED1 Pulsing with Direct Ambient Sampling

Dual-LED Pulsing with Direct Ambient Sampling

The optical timing diagram in [Figure 9](#) represents both LED1 and LED2 pulsing simultaneously with direct ambient sampling enabled. This timing mode would be used when heart rate is being measured with two green LEDs. In this mode, a single optical sampled value followed by the ambient sampled value will appear in successive the FIFO locations.

LED1 Pulsing with Direct Ambient Sampling

The optical timing diagram in [Figure 10](#) represents only LED1 pulsing during the data sampling time with direct ambient sampling enabled. This timing mode would be used when heart rate is being measured with a single green LED. In this mode, a single optical-sampled value, followed by the ambient sampled value, will appear successively in the FIFO.

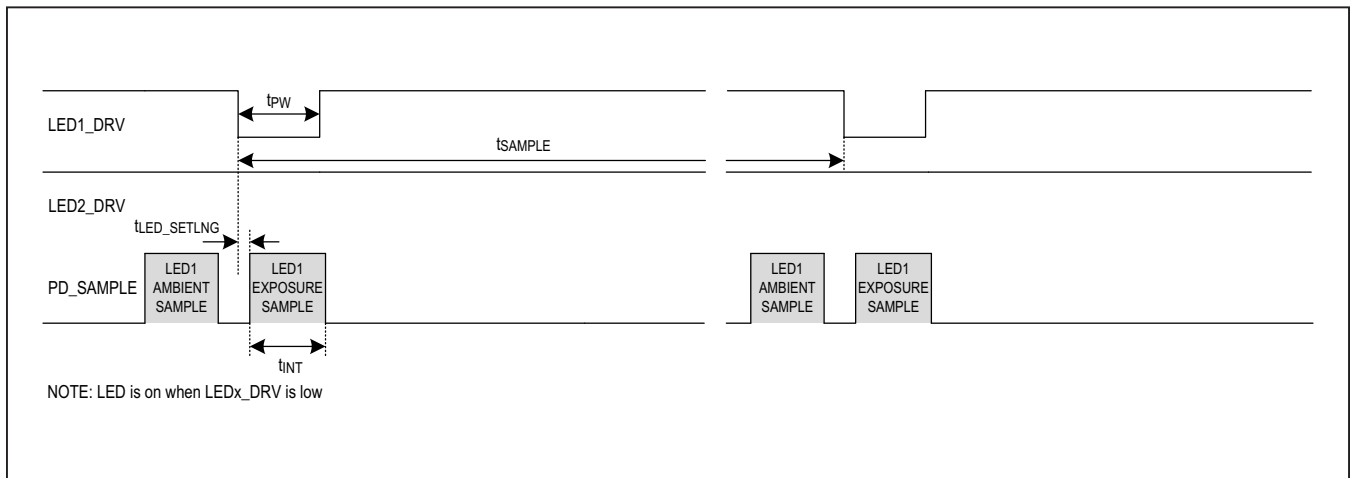

Figure 11: Timing for LED1 Pulsing with No Ambient Sampling

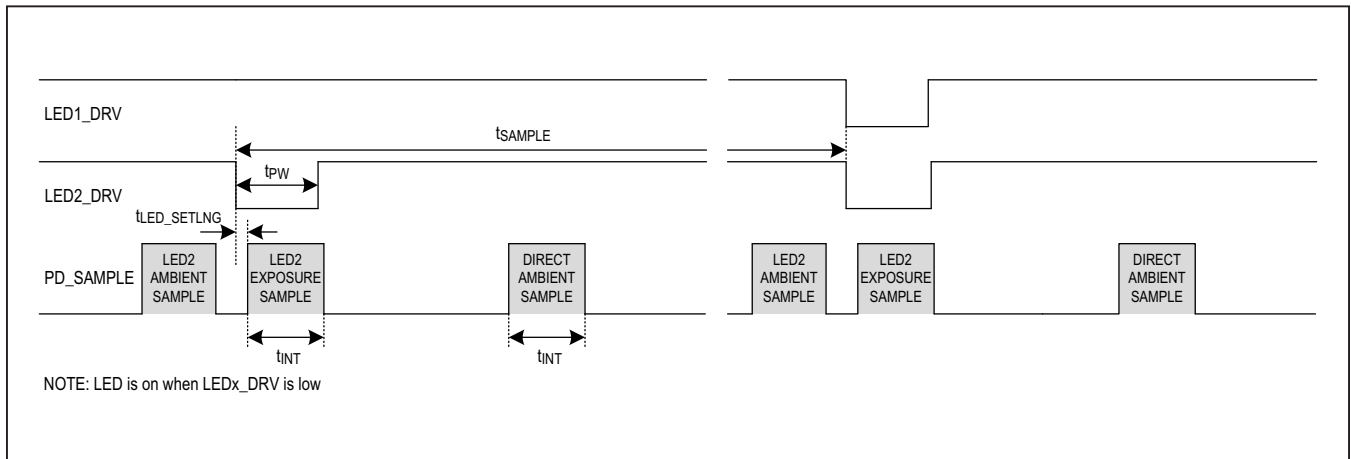

Figure 12: Timing for LED2 Pulsing with Direct Ambient Sampling

LED1 Pulsing with No Ambient Sampling

The optical timing diagram in [Figure 11](#) represents only LED1 pulsing during the data sampling time with no direct ambient sampling enabled. This timing mode would be used when heart rate is being measured with a single green LED. In this mode, a single optical sampled value will appear successively in the FIFO.

LED2 Pulsing with Direct Ambient Sampling

The optical timing diagram in [Figure 12](#) represents only LED2 firing during the data sampling time with direct

ambient sampling enabled. This timing mode would be used when heart rate is being measured with a single green LED. In this mode, a single optical sampled value, followed by the ambient sampled value, will appear successively in the FIFO.

LED2 Pulsing with No Ambient Sampling

The optical timing diagram in [Figure 13](#) represents only LED2 firing during the data sampling time with no direct ambient sampling enabled. This timing mode would be used when heart rates is being measured with a single

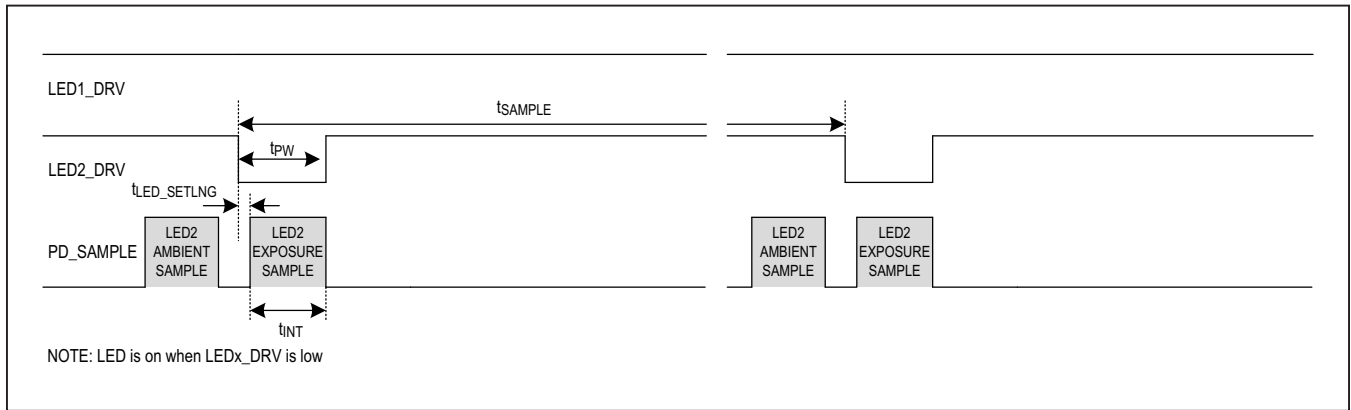

Figure 13: Timing for LED2 Pulsing with No Ambient Sampling

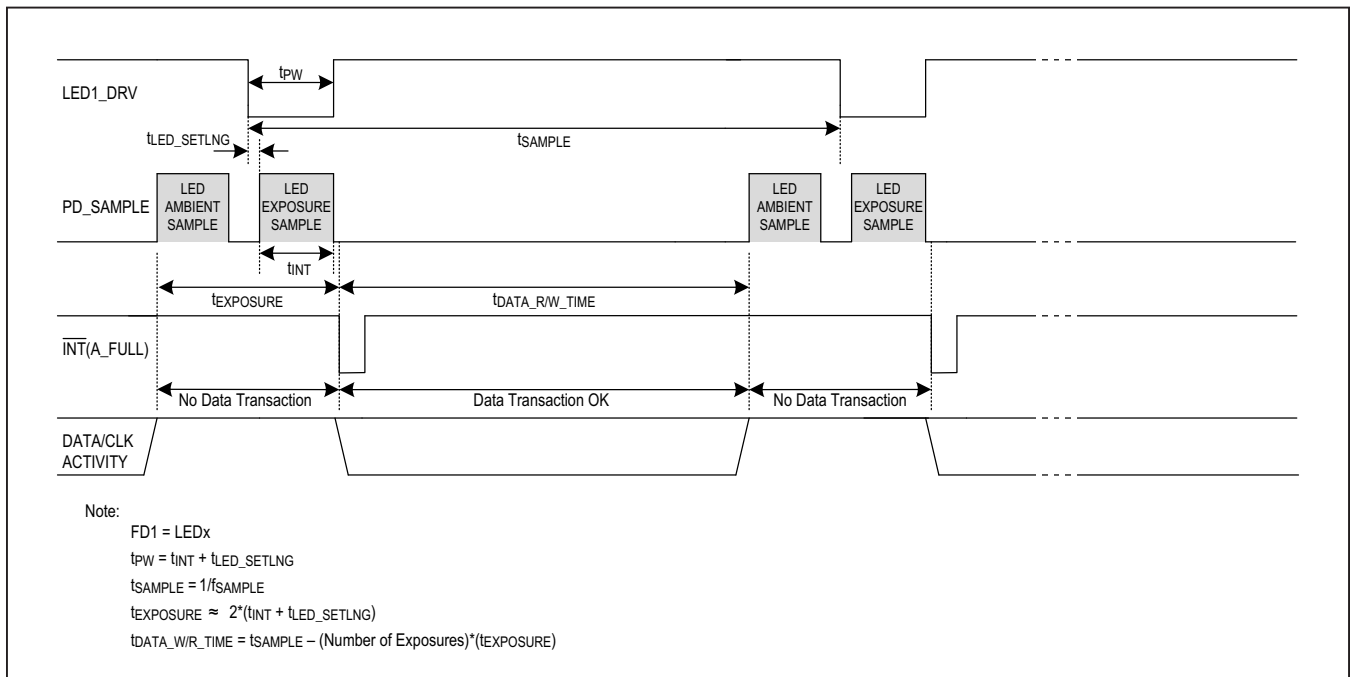

Figure 14. Readout Window for FIFO Read

green LED. In this mode, a single optical sampled value will appear successively in the FIFO.

FIFO Data Read Synchronization

Activity on the interface pins can bounce the on-chip GND potential, disturbing an optical sample, resulting in higher noise. Therefore, during a FIFO read event, it is recommended to time the FIFO read to occur between optical samples. This can be accomplished by reading the FIFO when the FIFO_A_FULL interrupt occurs and then limit the number of samples in the FIFO to those that can be read out during the time between samples. [Figure 14](#) illustrates how to place this read relative to the FIFO_A_FULL interrupt and the chosen sample rate, integration pulse width and LED settling time.

Proximity Function

The MAX30112 features proximity mode, which could significantly reduce energy consumption and extend battery life. In proximity mode, LED1 is pulsing at a lower current. When an object is present, the ADC count will exceed the preset threshold (PROX_INT_THRESH) and trigger the interrupt (PROX_INT). This functionality is only available when the FD1 timing slot is assigned to LED1. To use this function, it is necessary to set four register/bit fields correctly. These variables are the normal state LED current on LED1, LED1_PA (0x11), the proximity LED current, LED_PILOT_PA (0x15), the threshold code, PROX_INT_THRESH (0x10) and the proximity mode enable bit (Interrupt Enable1 (0x02, bit 4). Note that the threshold value is the code in register PROX_INT_THRESH (0x10) times 2048.

If the proximity feature is enabled, it will be switched to proximity mode when the LED1 ADC count drops below the threshold code, PROX_INT_THRESH(0x10). At this point, the LED1 drive current will be set from LED1_PA(0x11) to LED_PILOT_PA(0x15). Note that the threshold value is the code in register PROX_INT_THRESH (0x10) times 2048. This drop in LED current should generate sufficient hysteresis to guarantee that the MAX30112 does not toggle back and forth between proximity and normal mode operation.

Once in proximity mode, the MAX30112 will return to normal operating mode when the ADC count generated by the current programmed into the LED_PILOT_PA (0x15) register passes above the threshold in the PROX_INT_THRESH (0x10) register. When this occurs, the LED1 current will increase to the value assigned in LED1_PA (0x11) register, again providing sufficient hysteresis to guarantee a clean transition. Note that the threshold value is the code in register PROX_INT_THRESH (0x10) times 2048.

It is necessary to experiment with the specific optical geometry when configuring the proximity function. As a means of a starting point of this experimental work, it is recommended that the LED_PILOT_PA (0x15) register be set to about 1/10th the value of the LED1_PA (0x11) register. It is also recommended that the PROX_INT_THRESH (0x10) be set to roughly mid-way between the output code produced by the values of LED1_PA (0x11) and LED_PILOT_PA (0x15) when the optical device is correctly mounted to a subject.

Register Map

User Register Map

ADDRESS	NAME	MSB							LSB
STATUS									
0x00	Interrupt Status 1[7:0]	A_FULL	PPG_RDY	ALC_OVF	PROX_INT	LED_COMPB	-	-	PWR_RDY
0x01	Interrupt Status 2[7:0]	VDD_OOR	-	-	-	-	-	-	-
0x02	Interrupt Enable 1[7:0]	A_FULL_EN	PPG_RDY_EN	ALC_OVF_EN	PROX_INT_EN	LED_COMPB_EN	-	-	-
0x03	Interrupt Enable 2[7:0]	VDD_OOR_EN	-	-	-	-	-	-	-
FIFO									
0x04	FIFO Write Pointer[7:0]	-	-	-	FIFO_WR_PTR[4:0]				
0x05	Overflow Counter[7:0]	-	-	-	OVF_COUNTER[4:0]				
0x06	FIFO Read Pointer[7:0]	-	-	-	FIFO_RD_PTR[4:0]				
0x07	FIFO Data Register[7:0]	FIFO_DATA[7:0]							
0x08	FIFO Configuration[7:0]	-	FIFO_STAT_CLR	A_FULL_TYPE	FIFO_RO	FIFO_A_FULL[3:0]			

User Register Map continued

FIFO DATA CONTROL									
0x09	FIFO Data Control Register 1[7:0]	FD2[3:0]			FD1[3:0]				
0x0A	FIFO Data Control Register 2[7:0]	FD4[3:0]			FD3[3:0]				
SYSTEM CONTROL									
0x0D	System Control[7:0]	-	-	-	FCLK_CTRL	LP_MODE	FIFO_EN	SHDN	RESET
PPG CONFIGURATION									
0x0E	PPG Configuration 1[7:0]	PPG_ADC_RGE[1:0]		PPG_SR[3:0]			PPG_TINT[1:0]		
0x0F	PPG Configuration 2[7:0]	-	-	-	LED_SETLNG[1:0]		SMP_AVE[2:0]		
0x10	Prox Interrupt Threshold[7:0]	PROX_INT_THRESH[7:0]							
LED PULSE AMPLITUDE									
0x11	LED1 PA[7:0]	LED1_PA[7:0]							
0x12	LED2 PA[7:0]	LED2_PA[7:0]							
0x14	LED Range[7:0]	-	-	-	-	LED2_RGE[1:0]		LED1_RGE[1:0]	
0x15	LED PILOT PA[7:0]	PILOT_PA[7:0]							
PART ID									
0xFF	Part ID[7:0]	PART_ID[7:0]							

Interrupt Status 1 (0x00)

BIT	7	6	5	4	3	2	1	0
Field	A_FULL	PPG_RDY	ALC_OVF	PROX_INT	LED_COMPB	-	-	PWR_RDY
Reset	0x0	0x0	0x0	0x0	0x0	-	-	0x0
Access Type	Read Only	Read Only	Read Only	Read Only	Read Only	-	-	Read Only

A_FULL

VALUE	ENUMERATION	DECODE
0	OFF	Normal Operation
1	ON	Indicates that the FIFO buffer will overflow the threshold set by FIFO_A_FULL[3:0] on the next sample. This bit is cleared when the Interrupt Status 1 Register is read. It is also cleared when FIFO_DATA register is read, if A_FULL_CLR = 1

PPG_RDY

VALUE	ENUMERATION	DECODE
0	OFF	Normal Operation
1	ON	In LED1 and/or LED2 modes, this interrupt triggers if PPG_RDY_EN is set to 1, when there is a new sample in the data FIFO. The interrupt is cleared by reading the Interrupt Status 1 register (0x00). It is also cleared by reading the FIFO_DATA register if A_FULL_CLR is set to 1.

ALC_OVF

VALUE	ENUMERATION	DECODE
0	OFF	Normal Operation
1	ON	This interrupt triggers when the ambient light cancellation function of the PPG photodiode has reached its maximum limit due to overflow, and therefore, ambient light is affecting the output of the ADC. The interrupt is cleared by reading the Interrupt Status 1 register (0x00).

PROX_INT

VALUE	ENUMERATION	DECODE
0	OFF	Normal Operation
1	ON	Indicates that the proximity threshold has been crossed when in proximity mode. If PROX_INT is masked then the prox mode is disabled and the selected PPG mode begins immediately. This bit is cleared when the Interrupt Status 1 Register is read.

LED_COMPB

LED1 is not voltage compliant meaning that VLED1 < 160mV while LED1 pulses.: At the end of each sample, if the LED1 Driver is not voltage compliant, LED_COMPB interrupt is asserted if LED_COMPB_EN is set to 1. The interrupt is cleared when the status register is read.

VALUE	ENUMERATION	DECODE
0	COMPLIANT	LED1 driver voltage is in compliance
1	NOT_COMPLIANT	LED1 driver voltage is not in compliance

PWR_RDY

VALUE	ENUMERATION	DECODE
0	OFF	Normal Operation
1	ON	Indicates that VDD_DIG went below the 1.55V under voltage lockout threshold. This bit is also set upon a soft reset. This bit is cleared when Interrupt Status 1 Register is read.

Interrupt Status 2 (0x01)

BIT	7	6	5	4	3	2	1	0
Field	VDD_OOR	–	–	–	–	–	–	–
Reset	0x0	–	–	–	–	–	–	–
Access Type	Read Only	–	–	–	–	–	–	–

VDD_OOR

This is an indicator to check if the VDD_ANA supply voltage is within supported range.

VALUE	ENUMERATION	DECODE
0	OFF	VDD_ANA within supported range.
1	ON	Indicates that VDD_ANA is greater than 2.05V or less than 1.65V. This bit is automatically cleared when the Interrupt Status 2 register is read. The detection circuitry has a 10ms delay time, and will continue to trigger as long as the VDD_ANA is out of range.

Interrupt Enable 1 (0x02)

BIT	7	6	5	4	3	2	1	0
Field	A_FULL_EN	PPG_RDY_EN	ALC_OVF_EN	PROX_INT_EN	LED_COMPB_EN	–	–	–
Reset	0x0	0x0	0x0	0x0	0x0	–	–	–
Access Type	Write, Read	Write, Read	Write, Read	Write, Read	Write, Read	–	–	–

A_FULL_EN

VALUE	ENUMERATION	DECODE
0	OFF	A_FULL interrupt is disabled
1	ON	A_FULL interrupt in enabled

PPG_RDY_EN

VALUE	ENUMERATION	DECODE
0	OFF	PPG_RDY interrupt is disabled
1	ON	PPG_RDY interrupt is enabled.

ALC_OVF_EN

VALUE	ENUMERATION	DECODE
0	OFF	ALC_OVF interrupt is disabled
1	ON	ALC_OVF interrupt in enabled

PROX_INT_EN

When this is enabled, program LED1 into FD1 in FIFO Data Control register 1. LED1 must be used for proximity detection. If the ADC reading for this exposure is below 2048 times the threshold programmed in PROX_INT_THRESH register, the device is in proximity mode, otherwise it is in normal mode.

When the device is in proximity mode, the device starts data acquisition using only one exposure of LED1 and the LED current programmed in PILOT_PA register.

When the device is in normal mode, the device starts data acquisition using all the exposures programmed in the FIFO Data Control registers and appropriate LED currents.

When PROX_INT_EN is programmed to 1, PROX_INT interrupt is asserted when the devices enters normal mode (exit Proximity mode).

VALUE	ENUMERATION	DECODE
0	OFF	PROX_INT interrupt is disabled
1	ON	PROX_INT interrupt in enabled

LED_COMPB_EN

VALUE	ENUMERATION	DECODE
0	DISABLE	LED1 driver voltage compliance interrupt is disabled
1	ENABLE	LED1 driver voltage compliance interrupt is enabled

Interrupt Enable 2 (0x03)

BIT	7	6	5	4	3	2	1	0
Field	VDD_OOR_EN	–	–	–	–	–	–	–
Reset	0x0	–	–	–	–	–	–	–
Access Type	Write, Read	–	–	–	–	–	–	–

VDD_OOR_EN

VALUE	ENUMERATION	DECODE
0	OFF	Disables the VDD_OVR interrupt
1	ON	Enables the VDD_OVR interrupt

FIFO Write Pointer (0x04)

BIT	7	6	5	4	3	2	1	0
Field	–	–	–	FIFO_WR_PTR[4:0]				
Reset	–	–	–	0x00				
Access Type	–	–	–	Write, Read				

FIFO_WR_PTR

This points to the location where the next sample will be written. This pointer advances for each sample pushed on to the FIFO. Refer to FIFO Configuration for details.

Overflow Counter (0x05)

BIT	7	6	5	4	3	2	1	0
Field	–	–	–	OVF_COUNTER[4:0]				
Reset	–	–	–	0x00				
Access Type	–	–	–	Read Only				

OVF_COUNTER

When FIFO is full any new samples will result in new or old samples getting lost depending on FIFO_RO. OVF_COUNTER counts the number of samples lost. It saturates at 0x1F. Refer to FIFO Configuration for details.

FIFO Read Pointer (0x06)

BIT	7	6	5	4	3	2	1	0
Field	–	–	–	FIFO_RD_PTR[4:0]				
Reset	–	–	–	0x00				
Access Type	–	–	–	Write, Read				

FIFO_RD_PTR

The FIFO Read Pointer points to the location from where the processor gets the next sample from the FIFO. This advances each time a sample is popped from the FIFO. The processor can also write to this pointer after reading the samples. This allows rereading (or retrying) samples from the FIFO. Refer to FIFO Configuration for details.

FIFO Data Register (0x07)

BIT	7	6	5	4	3	2	1	0
Field	FIFO_DATA[7:0]							
Reset	0x00							
Access Type	Write, Read							

FIFO_DATA

This is a read-only register and is used to get data from the FIFO. Refer to [FIFO Configuration](#) for details.

FIFO Configuration (0x08)

BIT	7	6	5	4	3	2	1	0
Field	–	FIFO_STAT_CLR	A_FULL_TYPE	FIFO_RO	FIFO_A_FULL[3:0]			
Reset	–	0x0	0x0	0x0	0xF			
Access Type	–	Write, Read	Write, Read	Write, Read	Write, Read			

FIFO_STAT_CLR

This defines whether the A_FULL interrupt should get cleared by FIFO_DATA register read.

VALUE	ENUMERATION	DECODE
0	RD_DATA_NOCLR	A_FULL interrupt does not get cleared by FIFO_DATA register read. It gets cleared by status register read.
1	RD_DATA_CLR	A_FULL interrupt gets cleared by FIFO_DATA register read or status register read.

A_FULL_TYPE

This defines the behavior of the A_FULL interrupt.

VALUE	ENUMERATION	DECODE
0	AFULL_RPT	A_FULL interrupt gets asserted when the a_full condition is detected. It is cleared by status register read, but re-asserts for every sample if the a_full condition persists.
1	AFULL_ONCE	A_FULL interrupt gets asserted only when the a_full condition is detected. The interrupt gets cleared on status register read, and does not re-assert for every sample until a new a-full condition is detected.

FIFO_RO

Push enable when FIFO is full:

This bit controls the behavior of the FIFO when the FIFO becomes completely filled with data.

Push to FIFO is enabled when FIFO is full if FIFO_RO = 1. In this mode old samples are overwritten. FIFO_WR_PTR increments for each sample. FIFO_RD_PTR also increments for each sample pushed to the FIFO.

Push to FIFO is disabled when FIFO is full if FIFO_RO = 0. In this mode old samples are not overwritten and new samples are discarded . FIFO_WR_PTR does not increment for each sample after the FIFO is full.

When the device is in proximity mode, push to FIFO is enabled independent of FIFO_RO setting.

VALUE	ENUMERATION	DECODE
0	OFF	The FIFO stops on full.
1	ON	The FIFO automatically rolls over on full.

FIFO_A_FULL

These bits indicate how many unread samples are in the FIFO when the interrupt is asserted. For example, if set to 0xF, the interrupt triggers when there are 17 data samples in the FIFO (15 empty spaces left).

FIFO_A_FULL[3:0]	FREE SPACES AT INTERRUPT	# OF SAMPLES IN FIFO
0000	0	32
0001	1	31
0010	2	30
0011	3	29
----	----	----
1110	14	18
1111	15	17

FIFO Data Control Register 1 (0x09)

BIT	7	6	5	4	3	2	1	0
Field	FD2[3:0]				FD1[3:0]			
Reset	0x0				0x0			
Access Type	Write, Read				Write, Read			

FD2

These bits set the data type for Data Item 2 of the FIFO.
See [FIFO Configuration](#) for mode information.

FD1

These bits set the data type for Data Item 1 of the FIFO.
See [FIFO Configuration](#) for mode information.

FIFO Data Control Register 2 (0x0A)

BIT	7	6	5	4	3	2	1	0
Field	FD4[3:0]				FD3[3:0]			
Reset	0x0				0x0			
Access Type	Write, Read				Write, Read			

FD4

These bits set the data type for Data Item 4 of the FIFO.
See [FIFO Configuration](#) for mode information.

FD3

These bits set the data type for Data Item 3 of the FIFO.
See [FIFO Configuration](#) for mode information.

System Control (0x0D)

BIT	7	6	5	4	3	2	1	0
Field	–	–	–	FCLK_CTRL	LP_MODE	FIFO_EN	SHDN	RESET
Reset	–	–	–	0x0	0x0	0x0	0x0	0x0
Access Type	–	–	–	Write, Read	Write, Read	Write, Read	Write, Read	Write, Read

FCLK_CTRL

FCLK pin can be used for external 32kHz clock input when the PPG sample rate is 100sps and below. Used to synchronous multiple devices into one Clock domain.

VALUE	ENUMERATION	DECODE
0x0		FCLK pin is not used. Use internal 32KHz clock for PPG sample rates 100Hz and below.
0x1		Use external 32KHz clock at FCLK input for PPG sample rates 100Hz and below.

LP_MODE

In low power mode, the sensor can be dynamically powered down between samples to conserve power. This dynamic power-down mode option only supports samples rates of 100Hz and below.

VALUE	ENUMERATION	DECODE
0	OFF	Dynamic power down is disabled
1	ON	Dynamic power down is enabled. The device automatically enters low power mode between samples for samples rates 100Hz and below. This mode is not available for higher sample rates.

FIFO_EN

VALUE	ENUMERATION	DECODE
0	OFF	Push to FIFO is disabled, but the read and write pointers and the data in the FIFO are all held at their values before FIFO_EN is set to 0. The conversion and LED drivers are active until FD1 is set to NONE
1	ON	The FIFO is enabled. When this bit is set the FIFO is flushed of all old data and the new samples start loading from pointer zero. Setting this bit starts conversions and LED drivers enable according to the FDx settings.

SHDN

The part can be put into a power-save mode by setting this bit to one. While in power-save mode, all registers retain their values, and write/read operations function as normal. All interrupts are cleared to zero in this mode.

VALUE	ENUMERATION	DECODE
0	OFF	The part is in normal operation. No action taken.
1	ON	The part can be put into a power-save mode by writing a '1' to this bit. While in this mode all registers remain accessible and retain their data. ADC conversion data contained in the registers are previous values. Writeable registers also remain accessible in shutdown. All interrupts are cleared. In this mode the oscillator is shutdown and the part draws minimum current. If this bit is asserted during an active conversion then the conversion completes before the part shuts down.

RESET

VALUE	ENUMERATION	DECODE
0	OFF	The part is in normal operation. No action taken.
1	ON	The part under-goes a forced power-on-reset sequence. All configuration, threshold and data registers are reset to their power-on-state. This bit then automatically becomes '0' after the reset sequence is completed.

PPG Configuration 1 (0x0E)

BIT	7	6	5	4	3	2	1	0
Field	PPG_ADC_RGE[1:0]		PPG_SR[3:0]			PPG_TINT[1:0]		
Reset	0x0		0x0			0x0		
Access Type	Write, Read		Write, Read			Write, Read		

PPG_ADC_RGE

These bits set the ADC range of the photodiode sensor as shown in the table below.

PPG_ADC_RGE[1:0]	LSB (PA)	FULL SCALE (UA)
00	11.4	6
01	22.9	12
10	45.8	24
11	91.6	48

PPG_SR

These bits set the effective sampling rate of the PPG sensor as shown in the table below.

In Dual Pulse mode there are two pulses per sample, and the pulses are spaced to produce an additional 20dB of ambient rejection for indoor lighting cases (100Hz or 120Hz rejection).

If the sample rate, integration time, and number of Data Item are set to an invalid combination, the highest available sample rate will be automatically set for the integration and number of exposure setting. The user can read this register to confirm the sample rate.

PPG_SR[3:0]	FSAMPLE (SPS)	DUAL PULSE MODE
0000	20	No
0001	25	No
0010	50	No
0011	84	No
0100	100	No
0101	200	No
0110	400	No
0111	800	No
1000	1000	No
1001	1600	No
1010	3200	No
1011	20	Yes
1100	25	Yes
1101	50	Yes
1110	84	Yes
1111	100	Yes

See the following table for the maximum sample rates supported for all the integration time and number of Data Items.

NUMBER OF DATA ITEM PER SAMPLE	PPG_TINT = 0 (50US)	PPG_TINT= 1 (100US)	PPG_TINT= 2 (200US)	PPG_TINT= 3 (400US)
1 DATA ITEM, SINGLE PULSE MODE	3200	1600	1600	1000
2 DATA ITEMS, SINGLE PULSE MODE	1600	800	800	400
3 DATA ITEMS, SINGLE PULSE MODE	1000	800	400	200
4 DATA ITEMS, SINGLE PULSE MODE	1000	400	400	200
1 DATA ITEM, DUAL PULSE MODE	100	100	100	100
2 DATA ITEMS, DUAL PULSE MODE	100 for LP_MODE = 0, 50 for LP_MODE = 1	100 for LP_MODE = 0; 50 for LP_MODE = 1	84 for LP_MODE = 0; 50 for LP_MODE = 1	84 for LP_MODE = 0; 50 for LP_MODE = 1
3 DATA ITEMS, DUAL PULSE MODE	50	50	50	50
4 DATA ITEMS, DUAL PULSE MODE	50 for LP_MODE = 0; 25 for LP_MODE= 1	50 for LP_MODE = 0; 25 for LP_MODE = 1	25	25

PPG_TINT

These bits set the integration time of PPG ADC as well as the pulse width of the LEDS as shown in the table below.

t_{LED_SETLNG} is the delay programmed in the LED_SETLNG[1:0] register.

PPG_TINT[1:0]	TPW, LED PULSE WIDTH (MS)	TINT, INTEGRATION TIME (MS)	RESOLUTION BITS
00	$52 + t_{LED_SETLNG}$	52	16
01	$104 + t_{LED_SETLNG}$	104	17
10	$206 + t_{LED_SETLNG}$	206	18
11	$417 + t_{LED_SETLNG}$	417	19

PPG Configuration 2 (0x0F)

BIT	7	6	5	4	3	2	1	0
Field	–	–	–	LED_SETLNG[1:0]		SMP_AVE[2:0]		
Reset	–	–	–	0x3		0x0		
Access Type	–	–	–	Write, Read		Write, Read		

LED_SETLNG

Delay from rising edge of LED to start of ADC integration. This allows for the LED current to settle before the start of ADC integration.

LED_SETLNG[1:0]	DELAY t_{LED_SETLNG} (MS)
00	2.5
01	5.0
10	10.0
11	20.0

SMP_AVE

Adjacent samples (in each individual channel) can be internally averaged to reduce the amount of data throughput. These bits set the number of samples that are averaged on chip before being written to the FIFO. The effective output sample rate is the PPG_SR rate divided by the SMP_AVE value.

SMP_AVE[2:0]	SAMPLE AVERAGE
000	1 (no averaging)
001	2
010	4
011	8
100	16
101	32
110	32
111	32

Prox Interrupt Threshold (0x10)

BIT	7	6	5	4	3	2	1	0
Field	PROX_INT_THRESH[7:0]							
Reset	0x00							
Access Type	Write, Read							

PROX_INT_THRESH

This register sets the LED1 ADC count value that will trigger the transition between proximity mode to normal mode. The threshold is defined as the 8 MSB bits of the ADC count. For example, if PROX_INT_THRESH[7:0] = 0x01, then an ADC value of 2048 (decimal) or higher triggers the PROX interrupt. If PROX_INT_THRESH[7:0] = 0xFF, then only a saturated ADC triggers the interrupt.

See the [Proximity Function](#) section in the detailed description for more details on the operation of proximity mode.

LED1 PA (0x11)

BIT	7	6	5	4	3	2	1	0
Field	LED1_PA[7:0]							
Reset	0x00							
Access Type	Write, Read							

LED1_PA

These bits set the nominal peak current pulse amplitude of LEDx_DRV pin as shown in the table below.

Note: x denotes the respective LED channel.

LEDX_RGE[1:0]	00	01	10	11
LEDx_PA[7:0]	I _{LEDx_DRV} (mA)	I _{LEDx_DRV} (mA)	I _{LEDx_DRV} (mA)	I _{LEDx_DRV} (mA)
0x00	0	0	0	0
0x01	0.2	0.4	0.6	0.8
0x02	0.4	0.8	1.2	1.6
0x03	0.6	1.2	1.8	2.4
.....				
0xFC	49.4	98.8	148.2	197.6
0xFD	49.6	99.2	148.8	198.4
0xFE	49.8	99.6	149.4	198.2
0xFF	50	100	150	200
LSB	0.196	0.392	0.588	0.784

LED2 PA (0x12)

BIT	7	6	5	4	3	2	1	0
Field	LED2_PA[7:0]							
Reset	0x00							
Access Type	Write, Read							

LED2_PA

Refer to LED1_PA[1:0] for more details.

LED Range (0x14)

BIT	7	6	5	4	3	2	1	0
Field	-	-	-	-	LED2_RGE[1:0]		LED1_RGE[1:0]	
Reset	-	-	-	-	0x00		0x00	
Access Type	-	-	-	-	Write, Read		Write, Read	

LED2_RGE

Range selection of the LED 2 current.

Refer to LED1_PA[1:0] for more details.

LED2_RGE[1:0]	MAX LED CURRENT RANGE(MA)
00	50
01	100
10	150
11	200

LED1_RGE

Range selection of the LED 1 current.
Refer to LED1_PA[1:0] for more details.

LED1_RGE[1:0]	MAX LED CURRENT RANGE(MA)
00	50
01	100
10	150
11	200

LED PILOT PA (0x15)

BIT	7	6	5	4	3	2	1	0
Field	PILOT_PA[7:0]							
Reset	0x00							
Access Type	Write, Read							

PILOT_PA

In proximity mode, PILOT_PA[7:0] sets LED1 proximity mode current. These bits set the current pulse amplitude for proximity mode as shown in the table below. In proximity mode, LED1_RGE[1:0] and PILOT_PA[1:0] sets the LED1_DRV current.

See [Proximity Function](#) for more details on the operation of proximity mode.

LED1_RGE[1:0]	00	01	10	11
PILOT_PA[7:0]	I _{LED1_DRV} (mA)	I _{LED1_DRV} (mA)	I _{LED1_DRV} (mA)	I _{LED1_DRV} (mA)
0x00	0	0	0	0
0x01	0.2	0.4	0.6	0.8
0x02	0.4	0.8	1.2	1.6
0x03	0.6	1.2	1.8	2.4
.....				
0xFC	49.4	98.8	148.2	197.6
0xFD	49.6	99.2	148.8	198.4
0xFE	49.8	99.6	149.4	199.2
0xFF	50	100	150	200
LSB	0.2	0.4	0.6	0.8

Part ID (0xFF)

BIT	7	6	5	4	3	2	1	0
Field	PART_ID[7:0]							
Reset	0x20							
Access Type	Read Only							

PART_ID

This register stores the part identifier for the chip.

Typical Application Circuit

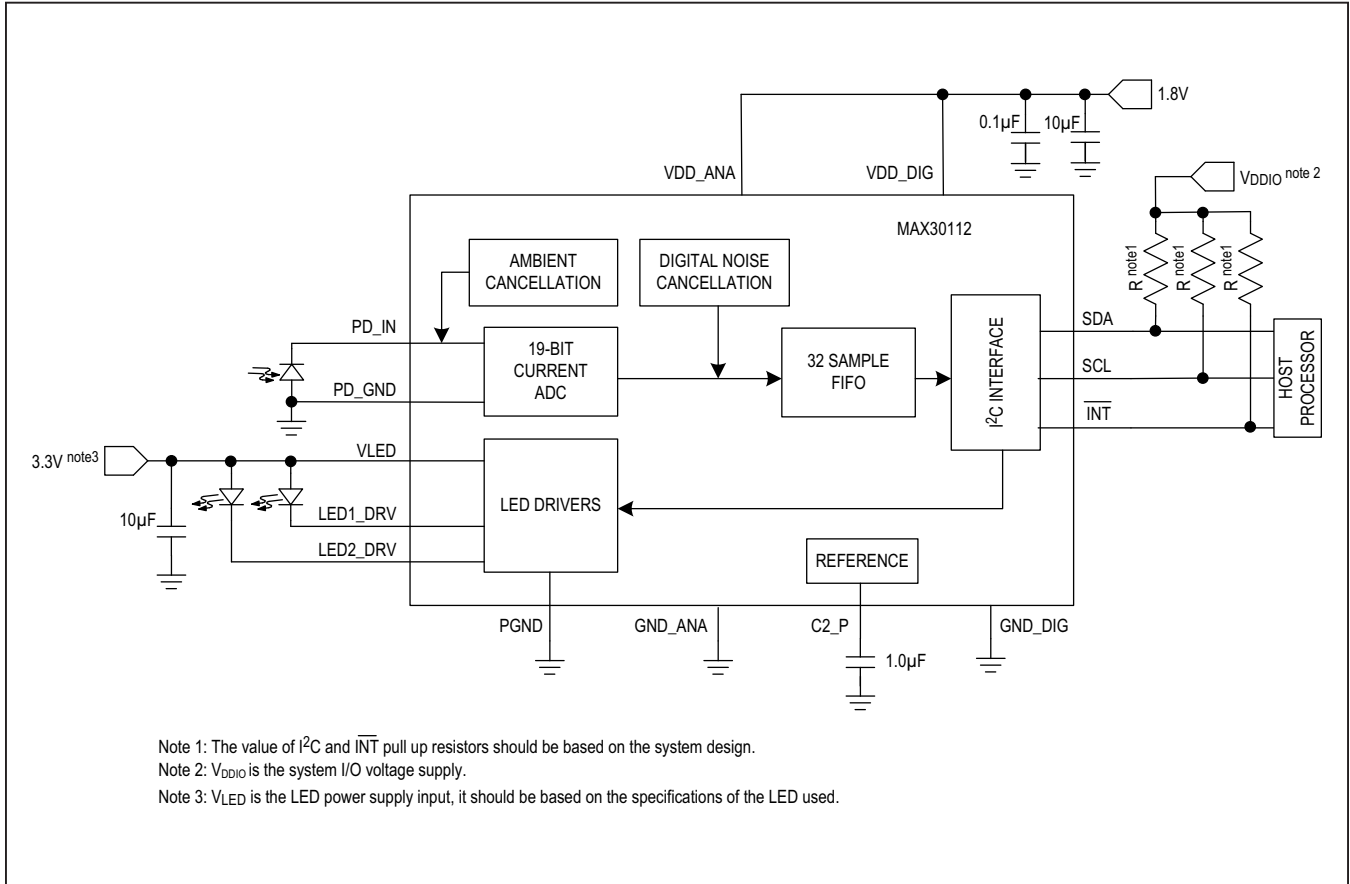

Ordering Information

PART	TEMP. RANGE	BUMP-PACKAGE
MAX30112EWG+	-40°C to +85°C	24-BUMP WLP 2.8mm x 2.0mm, 0.4mm Pitch

+Denotes a lead(Pb)-free/RoHS-compliant package

Revision History

REVISION NUMBER	REVISION DATE	DESCRIPTION	PAGES CHANGED
0	5/17	Initial release	—

For pricing, delivery, and ordering information, please contact Maxim Direct at 1-888-629-4642, or visit Maxim Integrated's website at www.maximintegrated.com.

Maxim Integrated cannot assume responsibility for use of any circuitry other than circuitry entirely embodied in a Maxim Integrated product. No circuit patent licenses are implied. Maxim Integrated reserves the right to change the circuitry and specifications without notice at any time. The parametric values (min and max limits) shown in the Electrical Characteristics table are guaranteed. Other parametric values quoted in this data sheet are provided for guidance.

Компания «Океан Электроники» предлагает заключение долгосрочных отношений при поставках импортных электронных компонентов на взаимовыгодных условиях!

Наши преимущества:

- Поставка оригинальных импортных электронных компонентов напрямую с производств Америки, Европы и Азии, а так же с крупнейших складов мира;
- Широкая линейка поставок активных и пассивных импортных электронных компонентов (более 30 млн. наименований);
- Поставка сложных, дефицитных, либо снятых с производства позиций;
- Оперативные сроки поставки под заказ (от 5 рабочих дней);
- Экспресс доставка в любую точку России;
- Помощь Конструкторского Отдела и консультации квалифицированных инженеров;
- Техническая поддержка проекта, помощь в подборе аналогов, поставка прототипов;
- Поставка электронных компонентов под контролем ВП;
- Система менеджмента качества сертифицирована по Международному стандарту ISO 9001;
- При необходимости вся продукция военного и аэрокосмического назначения проходит испытания и сертификацию в лаборатории (по согласованию с заказчиком);
- Поставка специализированных компонентов военного и аэрокосмического уровня качества (Xilinx, Altera, Analog Devices, Intersil, Interpoint, Microsemi, Actel, Aeroflex, Peregrine, VPT, Syfer, Eurofarad, Texas Instruments, MS Kennedy, Miteq, Cobham, E2V, MA-COM, Hittite, Mini-Circuits, General Dynamics и др.);

Компания «Океан Электроники» является официальным дистрибьютором и эксклюзивным представителем в России одного из крупнейших производителей разъемов военного и аэрокосмического назначения «JONHON», а так же официальным дистрибьютором и эксклюзивным представителем в России производителя высокотехнологичных и надежных решений для передачи СВЧ сигналов «FORSTAR».



JONHON

«JONHON» (основан в 1970 г.)

Разъемы специального, военного и аэрокосмического назначения:

(Применяются в военной, авиационной, аэрокосмической, морской, железнодорожной, горно- и нефтедобывающей отраслях промышленности)

«FORSTAR» (основан в 1998 г.)

ВЧ соединители, коаксиальные кабели, кабельные сборки и микроволновые компоненты:

(Применяются в телекоммуникациях гражданского и специального назначения, в средствах связи, РЛС, а так же военной, авиационной и аэрокосмической отраслях промышленности).



Телефон: 8 (812) 309-75-97 (многоканальный)

Факс: 8 (812) 320-03-32

Электронная почта: ocean@oceanchips.ru

Web: <http://oceanchips.ru/>

Адрес: 198099, г. Санкт-Петербург, ул. Калинина, д. 2, корп. 4, лит. А