

FEATURES

- Dual transceivers for RS-422
- ESD protection on bus input/output pins
 - ±15 kV human body model (HBM)
 - ±8 kV IEC 61000-4-2, contact discharge
 - ±8 kV IEC 61000-4-2, air discharge
- Complies with TIA/EIA-422-B and ITU-T recommendation V.11
- Open-circuit fail-safe
- Suitable for 5 V power supply applications
- Low supply current operation: 9 mA maximum
- Low driver output skew
- Receiver input impedance: 30 kΩ
- Receiver common-mode range: -7 V to +7 V
- Power-up/power-down without glitches
- 16-pin TSSOP package
- Operating temperature range: -40°C to +85°C

APPLICATIONS

- RS-422 interfaces
- High data rate motor control
- Single-ended-to-differential signal conversion
- Point-to-point and multidrop transmission systems

GENERAL DESCRIPTION

The [ADM4168E](#) has dual RS-422 transceivers suitable for high speed communication on point-to-point and multidrop transmission lines. The [ADM4168E](#) is designed for balanced transmission lines and complies with TIA/EIA-422-B.

The differential driver outputs and receiver inputs feature electrostatic discharge circuitry that provides protection up to ±15 kV HBM and ±8 kV IEC 61000-4-2 (contact and air discharge).

The [ADM4168E](#) operates from a single 5 V power supply. Excessive power dissipation caused by bus contention or output shorting is prevented by short-circuit protection circuitry. Short-circuit protection circuits limit the maximum output current to 150 mA during fault conditions.

FUNCTIONAL BLOCK DIAGRAM

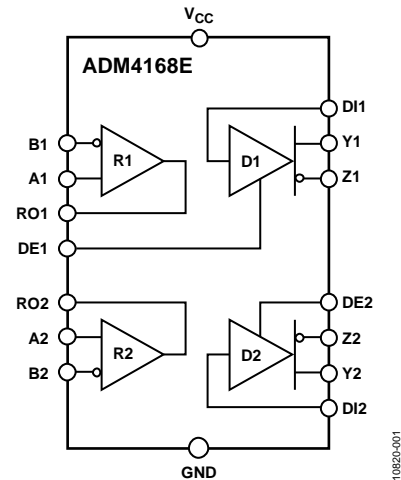

Figure 1.

The receivers of the [ADM4168E](#) contain a fail-safe feature that results in a logic high output state if the inputs are unconnected (floating).

The [ADM4168E](#) is fully specified over the commercial and industrial temperature ranges and is available in a 16-pin TSSOP package.

Rev. 0

Information furnished by Analog Devices is believed to be accurate and reliable. However, no responsibility is assumed by Analog Devices for its use, nor for any infringements of patents or other rights of third parties that may result from its use. Specifications subject to change without notice. No license is granted by implication or otherwise under any patent or patent rights of Analog Devices. Trademarks and registered trademarks are the property of their respective owners.

TABLE OF CONTENTS

Features	1	Pin Configuration and Function Descriptions.....	6
Applications.....	1	Typical Performance Characteristics	7
Functional Block Diagram	1	Test Circuits and Switching Characteristics.....	9
General Description	1	Driver Measurements	9
Revision History	2	Receiver Measurements.....	9
Specifications.....	3	Theory of Operation	10
Timing Specifications	4	Truth Tables.....	10
Absolute Maximum Ratings.....	5	Outline Dimensions	11
Thermal Resistance	5	Ordering Guide	11
ESD Caution.....	5		

REVISION HISTORY

9/12—Revision 0: Initial Version

SPECIFICATIONS

$4.5\text{ V} \leq V_{CC} \leq 5.5\text{ V}$; all minimum/maximum specifications apply over the entire recommended operation range, unless otherwise noted. All typical specifications are at $T_A = 25^\circ\text{C}$, $V_{CC} = 5.0\text{ V}$, unless otherwise noted.

Table 1.

Parameter	Symbol	Min	Typ	Max	Unit	Test Conditions/Comments
SUPPLY CURRENT						
Total Package	I_{CC}		4 5	6 9	mA mA	No load, drivers enabled $V_I = V_{CC}$ or GND $V_I = 2.4\text{ V}$ or 0.5 V^1
DRIVER						
Differential Outputs (Y1, Z1, Y2, Z2 Pins)						
Input Clamp Voltage	V_{IK}			-1.5	V	$I_I = -18\text{ mA}$
Output Voltage High	V_{OH}	2.4	3.5		V	$V_{IH} = 2\text{ V}$, $V_{IL} = 0.8\text{ V}$, $I_{OH} = -20\text{ mA}$
Output Voltage Low	V_{OL}		0.2	0.4	V	$V_{IH} = 2\text{ V}$, $V_{IL} = 0.8\text{ V}$, $I_{OL} = 20\text{ mA}$
Differential Output Voltage						
No Load	$ V_{OD1} $	2.0		6.0	V	$I_O = 0\text{ mA}$
Outputs Loaded ²	$ V_{OD2} $	2.0	3.7		V	$R_L = 100\ \Omega$ (see Figure 11)
$\Delta V_{OD} $ for Complementary Output States	$\Delta V_{OD} $			± 0.4	V	$R_L = 100\ \Omega$ (see Figure 11)
Common-Mode Output Voltage	V_{OC}			± 3.0	V	$R_L = 100\ \Omega$ (see Figure 11)
$\Delta V_{OC} $ for Complementary Output States	$\Delta V_{OC} $			± 0.4	V	$R_L = 100\ \Omega$ (see Figure 11)
Output Leakage Current	I_O			100	μA	$DE = 0\text{ V}$, $V_{CC} = 0\text{ V}$ or 5 V , $V_O = 6\text{ V}$
		-100			μA	$DE = 0\text{ V}$, $V_{CC} = 0\text{ V}$ or 5 V , $V_O = -0.25\text{ V}$
Output Current (Short Circuit) ³	I_{OS}	-30		-150	mA	$V_O = V_{CC}$ or GND
Input Capacitance	C_I		6		pF	
Logic Inputs (DI, DE Pins)						
Input Voltage High	V_{IH}	2.0			V	
Input Voltage Low	V_{IL}			0.8	V	
Input Current High	I_{IH}			1	μA	$V_I = V_{CC}$ or V_{IH}
Input Current Low	I_{IL}			-1	μA	$V_I = \text{GND}$ or V_{IL}
RECEIVER						
Differential Inputs (A1, B1, A2, B2 Pins)						
Differential Input Threshold Voltage ²	V_{TH}	-200		+200	mV	
Input Voltage Hysteresis	V_{HYS}		60		mV	
Input Current	I_I			1.5 -2.5	mA mA	$V_I = 7\text{ V}$, other input at 0 V $V_I = -7\text{ V}$, other input at 0 V
Line Input Resistance	R_{IN}	12	30		k Ω	$V_{IC} = -7\text{ V}$ to $+7\text{ V}$, other input at 0 V
Logic Outputs (RO1, RO2 Pins)						
Output Voltage High	V_{OH}	3.8	4.2		V	$V_{ID} = 200\text{ mV}$, $I_{OH} = -6\text{ mA}$
Output Voltage Low	V_{OL}		0.1	0.3	V	$V_{ID} = -200\text{ mV}$, $I_{OL} = 6\text{ mA}$

¹ Measured per input with other inputs at V_{CC} or GND.

² For exact conditions, see TIA/EIA-422-B.

³ No more than one output shorted at any time, with the duration of the short not to exceed 1 second.

TIMING SPECIFICATIONS

4.5 V \leq V_{CC} \leq 5.5 V; all minimum/maximum specifications apply over the entire recommended operation range, unless otherwise noted. All typical specifications are at T_A = 25°C, V_{CC} = 5.0 V, unless otherwise noted.

Table 2.

Parameter	Symbol	Min	Typ	Max	Unit	Test Conditions/Comments
DRIVER						
Propagation Delay	t _{DPLH} , t _{DPHL}		8	16	ns	R ₁ , R ₂ = 50 Ω; R ₃ = 500 Ω; C ₁ , C ₂ , C ₃ = 40 pF S1 open (see Figure 12 and Figure 13)
Driver Output Skew	t _{SK}		1.5	4	ns	S1 open (see Figure 12 and Figure 13)
Rise Time/Fall Time	t _{DR} , t _{DF}		5	10	ns	S1 open (see Figure 12 and Figure 13)
Enable Time	t _{ZH} , t _{ZL}		10	19	ns	S1 closed (see Figure 13 and Figure 14)
Disable Time	t _{HZ} , t _{LZ}		7	16	ns	S1 closed (see Figure 13 and Figure 14)
RECEIVER¹						
Propagation Delay	t _{RPLH} , t _{RPHL}	9	15	27	ns	C _L = 50 pF (see Figure 15 and Figure 16)
Transition Time	t _{TLH} , t _{THL}		4	9	ns	V _{IC} = 0 V, C _L = 50 pF (see Figure 15 and Figure 16)

¹ Measured per input with other inputs at V_{CC} or GND.

ABSOLUTE MAXIMUM RATINGS

Table 3.

Parameter	Rating
V_{CC}	-0.3 V to +7 V
Digital Input Voltage (DE1, DE2)	-0.3 V to +7 V
Driver Input Voltage (DI1, DI2)	-0.3 V to +7 V
Receiver Output Voltage (RO1, RO2)	-0.3 V to $V_{CC} + 0.3$ V
Driver Output Voltage (Y1, Z1, Y2, Z2)	-0.3 V to +7 V
Receiver Input Voltage (A1, B1, A2, B2)	-14 V to +14 V
Operating Temperature Range	-40°C to +85°C
Storage Temperature Range	-65°C to +150°C
ESD Protection on Ax, Bx, Yx, and Zx	
Human Body Model (HBM)	±15 kV
IEC 61000-4-2, Contact Discharge	±8 kV
IEC 61000-4-2, Air Discharge	±8 kV

Stresses above those listed under Absolute Maximum Ratings may cause permanent damage to the device. This is a stress rating only; functional operation of the device at these or any other conditions above those indicated in the operational section of this specification is not implied. Exposure to absolute maximum rating conditions for extended periods may affect device reliability.

THERMAL RESISTANCE

θ_{JA} is specified for the worst-case conditions, that is, a device soldered in a circuit board for surface-mount packages.

Table 4. Thermal Resistance

Package Type	θ_{JA}	Unit
16-Lead TSSOP	113	°C/W

ESD CAUTION



ESD (electrostatic discharge) sensitive device. Charged devices and circuit boards can discharge without detection. Although this product features patented or proprietary protection circuitry, damage may occur on devices subjected to high energy ESD. Therefore, proper ESD precautions should be taken to avoid performance degradation or loss of functionality.

PIN CONFIGURATION AND FUNCTION DESCRIPTIONS

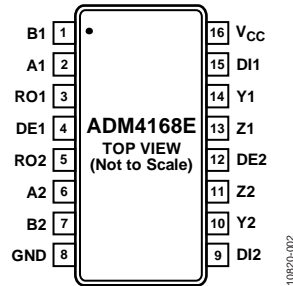

Figure 2. Pin Configuration

Table 5. Pin Function Descriptions

Pin No.	Mnemonic	Description
1	B1	Inverting Receiver Input B, Transceiver 1.
2	A1	Noninverting Receiver Input A, Transceiver 1.
3	RO1	Receiver Output, Transceiver 1.
4	DE1	Driver Output Enable, Transceiver 1. A logic high enables the differential driver outputs, Y1 and Z1; a logic low places the differential driver outputs in a high impedance state.
5	RO2	Receiver Output, Transceiver 2.
6	A2	Noninverting Receiver Input A, Transceiver 2.
7	B2	Inverting Receiver Input B, Transceiver 2.
8	GND	Ground.
9	DI2	Driver Input, Transceiver 2. When the driver is enabled, a logic low on DI2 forces Y2 low and Z2 high, whereas a logic high on DI2 forces Y2 high and Z2 low.
10	Y2	Noninverting Driver Output Y, Transceiver 2.
11	Z2	Inverting Driver Output Z, Transceiver 2.
12	DE2	Driver Output Enable, Transceiver 2. A logic high enables the differential driver outputs, Y2 and Z2; a logic low places the differential driver outputs in a high impedance state.
13	Z1	Inverting Driver Output Z, Transceiver 1.
14	Y1	Noninverting Driver Output Y, Transceiver 1.
15	DI1	Driver Input, Transceiver 1. When the driver is enabled, a logic low on DI1 forces Y1 low and Z1 high, whereas a logic high on DI1 forces Y1 high and Z1 low.
16	V _{CC}	Power Supply (5 V ± 10%).

TYPICAL PERFORMANCE CHARACTERISTICS

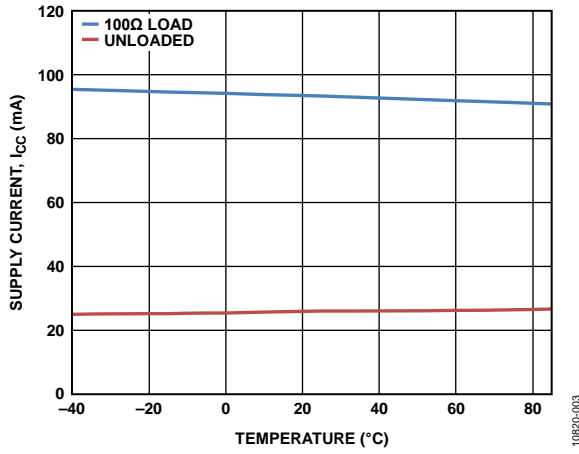

Figure 3. Supply Current vs. Temperature, Data Rate = 10 Mbps

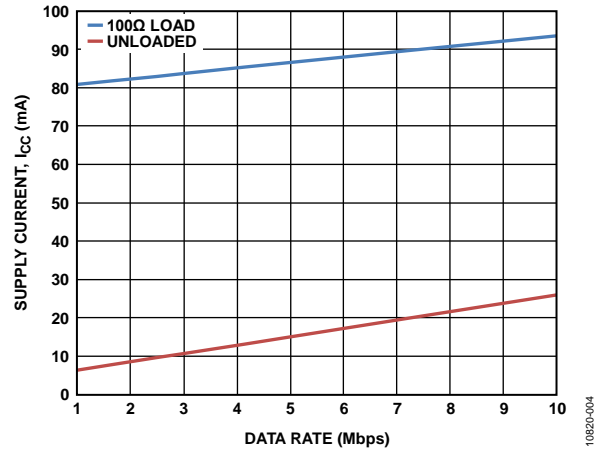

Figure 6. Supply Current vs. Data Rate

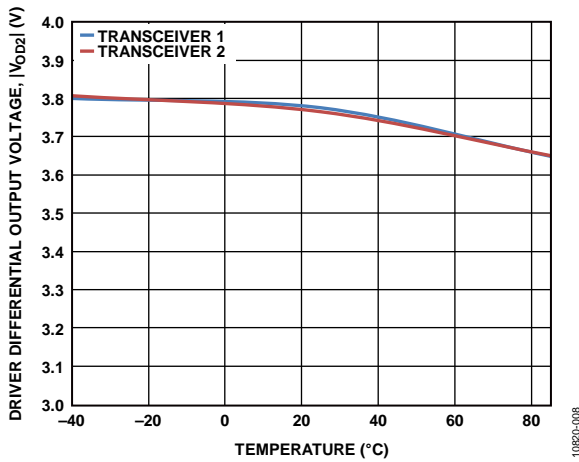

Figure 4. Driver Differential Output Voltage vs. Temperature

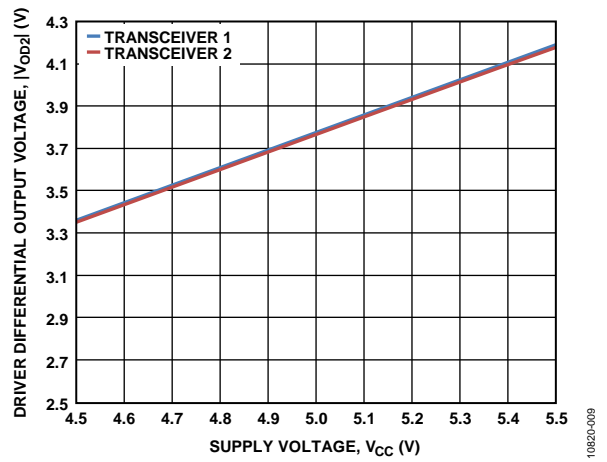

Figure 7. Driver Differential Output Voltage vs. Supply Voltage

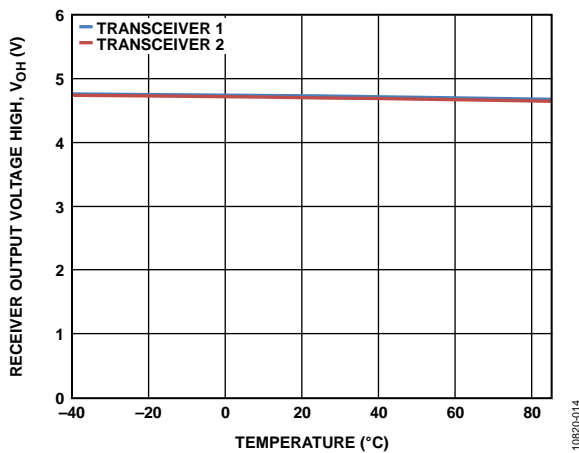

Figure 5. Receiver Output Voltage High vs. Temperature

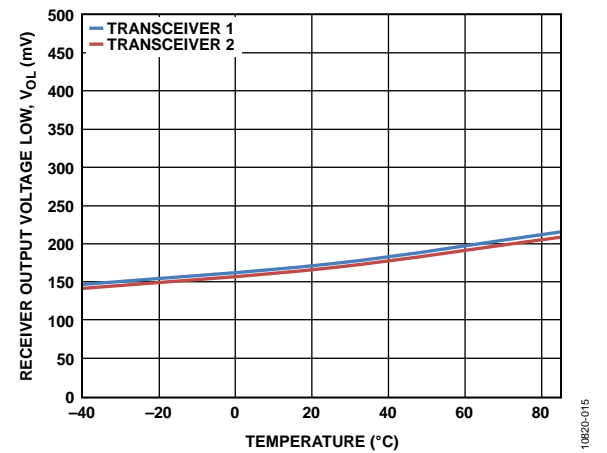

Figure 8. Receiver Output Voltage Low vs. Temperature

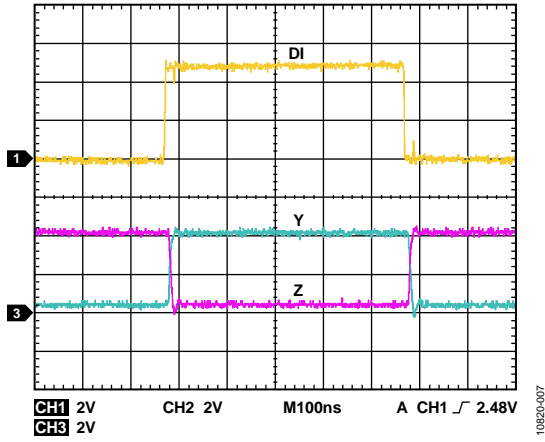

Figure 9. Driver Output

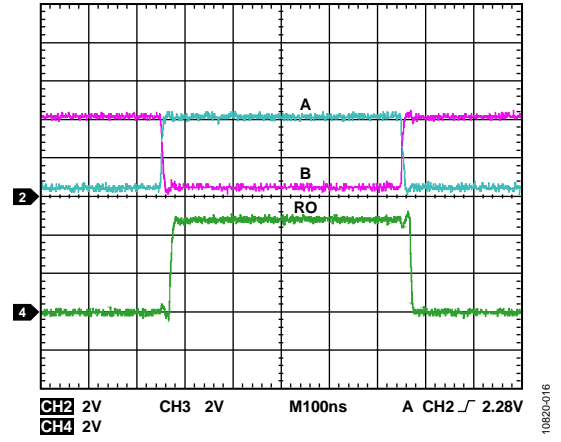

Figure 10. Receiver Output

TEST CIRCUITS AND SWITCHING CHARACTERISTICS

DRIVER MEASUREMENTS

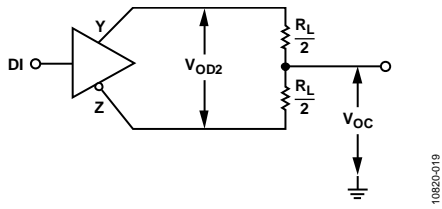
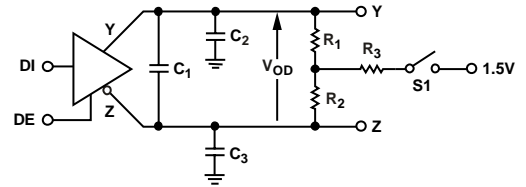
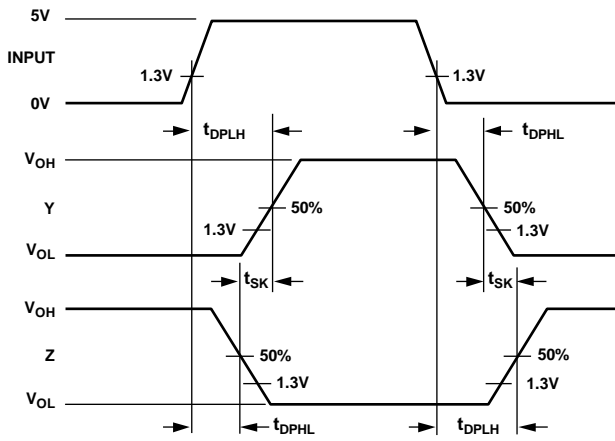

Figure 11. Driver Voltage Measurements



NOTES
1. C₁, C₂, C₃ INCLUDE PROBE/INSTRUMENT CAPACITANCE.

Figure 13. Driver Timing Circuit



NOTES
1. INPUT PULSE GENERATOR: PPR 1MHz; 50% DUTY CYCLE; $t_r, t_f \leq 6\text{ns}$.

Figure 12. Driver Propagation Delay and Rise/Fall Timing

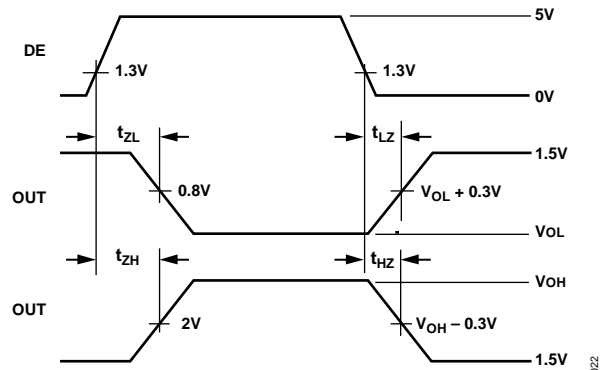

NOTES
1. INPUT PULSE GENERATOR: PPR 1MHz; 50% DUTY CYCLE; $t_r, t_f \leq 6\text{ns}$.

Figure 14. Driver Enable/Disable Timing

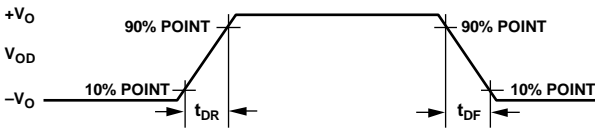

RECEIVER MEASUREMENTS

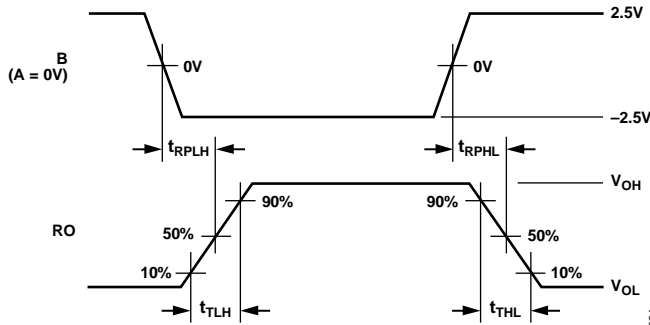

NOTES
1. INPUT PULSE GENERATOR: PPR 1MHz; 50% DUTY CYCLE; $t_r, t_f \leq 6\text{ns}$.

Figure 15. Receiver Propagation Delay and Transition Timing

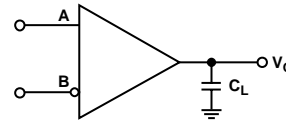

NOTES
1. C_L INCLUDES PROBE/INSTRUMENT CAPACITANCE.

Figure 16. Receiver Timing Circuit

THEORY OF OPERATION

The **ADM4168E** is a dual RS-422 transceiver that operates from a single 5 V ± 10% power supply. The **ADM4168E** is intended for balanced data transmission and complies with TIA/EIA-422-B and ITU-T recommendation V.11. Each device contains two differential line drivers and two differential line receivers and is suitable for full-duplex data transmission.

The receivers contain a fail-safe feature that results in a logic high output state if the inputs are unconnected (floating).

The **ADM4168E** features a low propagation delay, ensuring maximum baud rate operation. The balanced driver ensures distortion-free transmission.

Another important specification is a measure of the skew between the complementary outputs. Low skew enhances the noise immunity of the system and decreases the amount of electromagnetic interference (EMI).

TRUTH TABLES

Table 6. Abbreviations in Truth Tables

Letter	Description
H	High level
I	Indeterminate
L	Low level
X	Irrelevant
Z	High impedance (off)

Table 7. Transmitting (Each Driver)

Inputs		Outputs	
DE	DI	Z	Y
H	H	L	H
H	L	H	L
L	X	Z	Z

Table 8. Receiving (Each Receiver)

Inputs	Output
A – B	RO
≥ +0.2 V	H
≤ -0.2 V	L
-0.2 V < A – B < +0.2 V	I
Inputs open	H

OUTLINE DIMENSIONS

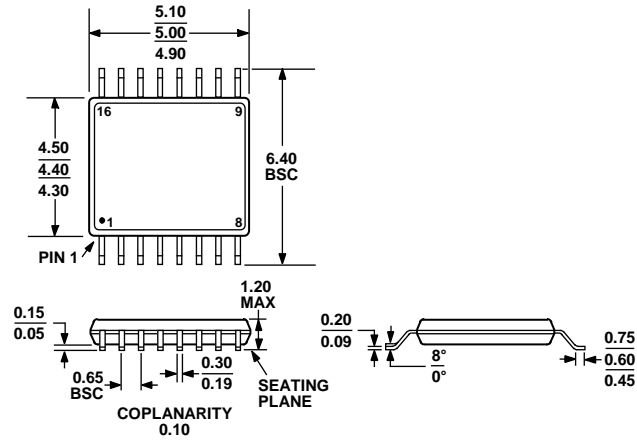

COMPLIANT TO JEDEC STANDARDS MO-153-AB

Figure 17. 16-Lead Thin Shrink Small Outline Package [TSSOP] (RU-16)

Dimensions shown in millimeters

ORDERING GUIDE

Model ¹	Temperature Range	Package Description	Package Option
ADM4168EBRUZ	-40°C to +85°C	16-Lead Thin Shrink Small Outline Package [TSSOP]	RU-16
ADM4168EBRUZ-RL7	-40°C to +85°C	16-Lead Thin Shrink Small Outline Package [TSSOP]	RU-16
EVAL-ADM4168EEBZ		Evaluation Board	

¹ Z = RoHS Compliant Part.

NOTES

Компания «Океан Электроники» предлагает заключение долгосрочных отношений при поставках импортных электронных компонентов на взаимовыгодных условиях!

Наши преимущества:

- Поставка оригинальных импортных электронных компонентов напрямую с производств Америки, Европы и Азии, а так же с крупнейших складов мира;
- Широкая линейка поставок активных и пассивных импортных электронных компонентов (более 30 млн. наименований);
- Поставка сложных, дефицитных, либо снятых с производства позиций;
- Оперативные сроки поставки под заказ (от 5 рабочих дней);
- Экспресс доставка в любую точку России;
- Помощь Конструкторского Отдела и консультации квалифицированных инженеров;
- Техническая поддержка проекта, помощь в подборе аналогов, поставка прототипов;
- Поставка электронных компонентов под контролем ВП;
- Система менеджмента качества сертифицирована по Международному стандарту ISO 9001;
- При необходимости вся продукция военного и аэрокосмического назначения проходит испытания и сертификацию в лаборатории (по согласованию с заказчиком);
- Поставка специализированных компонентов военного и аэрокосмического уровня качества (Xilinx, Altera, Analog Devices, Intersil, Interpoint, Microsemi, Actel, Aeroflex, Peregrine, VPT, Syfer, Eurofarad, Texas Instruments, MS Kennedy, Miteq, Cobham, E2V, MA-COM, Hittite, Mini-Circuits, General Dynamics и др.);

Компания «Океан Электроники» является официальным дистрибьютором и эксклюзивным представителем в России одного из крупнейших производителей разъемов военного и аэрокосмического назначения «JONHON», а так же официальным дистрибьютором и эксклюзивным представителем в России производителя высокотехнологичных и надежных решений для передачи СВЧ сигналов «FORSTAR».



JONHON

«JONHON» (основан в 1970 г.)

Разъемы специального, военного и аэрокосмического назначения:

(Применяются в военной, авиационной, аэрокосмической, морской, железнодорожной, горно- и нефтедобывающей отраслях промышленности)

«FORSTAR» (основан в 1998 г.)

ВЧ соединители, коаксиальные кабели, кабельные сборки и микроволновые компоненты:

(Применяются в телекоммуникациях гражданского и специального назначения, в средствах связи, РЛС, а так же военной, авиационной и аэрокосмической отраслях промышленности).



Телефон: 8 (812) 309-75-97 (многоканальный)

Факс: 8 (812) 320-03-32

Электронная почта: ocean@oceanchips.ru

Web: <http://oceanchips.ru/>

Адрес: 198099, г. Санкт-Петербург, ул. Калинина, д. 2, корп. 4, лит. А