

DS1626/DS1726

High-Precision 3-Wire Digital Thermometer and Thermostat

www.maxim-ic.com

DESCRIPTION

The DS1626 and DS1726 digital thermometers/thermostats provide temperature measurements and stand-alone thermostat capability over a -55°C to +125°C range. The DS1626 offers ±0.5°C accuracy from 0°C to +70°C and the DS1726 has ±1°C accuracy from -10°C to +85°C. The resolution of the measured temperature is user selectable from 9 to 12 bits. Communication with the DS1626 and DS1726 is achieved through a 3-wire serial bus.

The DS1626 and DS1726 offer thermostatic functionality with three dedicated thermostat outputs (T_{HIGH}, T_{LOW}, and T_{COM}), and overtemperature (T_H) and undertemperature (T_L) user-programmable thresholds stored in on-chip EEPROM. For stand-alone thermostat operation, T_H and T_L can be programmed prior to installation, and the DS1626/DS1726 can be configured to automatically begin taking temperature measurements at power-up. Table 1 summarizes the user-accessible registers. Figure 1 shows a functional diagram.

APPLICATIONS

Thermostatic Controls
 Industrial Controls
 Consumer Products
 Any Space-Constrained Thermally Sensitive Application

FEATURES

- Temperature Measurements Require No External Components
- Measure Temperatures from -55°C to +125°C (-67°F to +257°F)
- DS1626: ±0.5°C Accuracy from 0°C to +70°C
- DS1726: ±1°C Accuracy from -10°C to +85°C
- Output Resolution is User Selectable to 9, 10, 11, or 12 Bits
- Wide Power-Supply Range (2.7V to 5.5V)
- Convert Temperature to Digital Word in 750ms (max)
- Stand-Alone Thermostat Capability
- Thermostatic Settings are User Definable and Nonvolatile (NV)
- Data is Read/Written Through a 3-Wire Serial Interface
- Available in 8-Pin μSOP Package

PIN CONFIGURATION

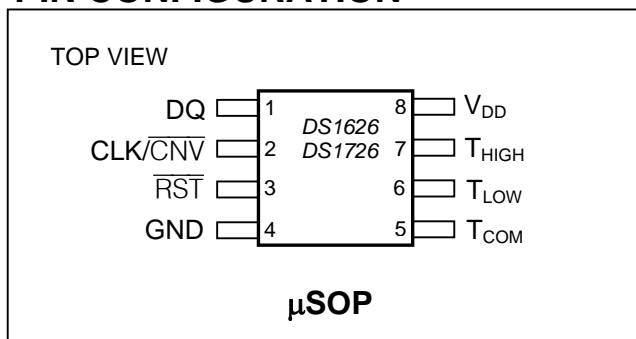

ORDERING INFORMATION

PART	TEMP RANGE	PIN-PACKAGE	TOP MARK
DS1626U	-55°C to +125°C	8 μSOP	1626
DS1626U+	-55°C to +125°C	8 μSOP	1626
DS1626U/T&R	-55°C to +125°C	8 μSOP, 3000-Piece	1626
DS1626U+T&R	-55°C to +125°C	8 μSOP, 3000-Piece	1626
DS1726U	-55°C to +125°C	8 μSOP	1726
DS1726U+	-55°C to +125°C	8 μSOP	1726
DS1726U/T&R	-55°C to +125°C	8 μSOP, 3000-Piece	1726
DS1726U+T&R	-55°C to +125°C	8 μSOP, 3000-Piece	1726

+Denotes a lead-free package. A "+" symbol will also be marked on the package near the Pin 1 indicator.
 T&R = Tape and reel.

PIN DESCRIPTION

PIN	NAME	FUNCTION
1	DQ	Data Input/Output Pin (Tri-State) for 3-Wire Serial Communication
2	CLK/ $\overline{\text{CNV}}$	Clock Input Pin for 3-Wire Serial Communication. Controls temperature measurements when the DS1626/DS1726 is configured as a stand-alone thermostat.
3	$\overline{\text{RST}}$	Reset Input Pin for 3-Wire Serial Communication
4	GND	Ground Pin
5	T _{COM}	Thermostat Output Pin (Push-Pull) with Programmable Hysteresis
6	T _{LOW}	Thermostat Output Pin (Push-Pull) with T _L Trip Point
7	T _{HIGH}	Thermostat Output Pin (Push-Pull) with T _H Trip Point
8	V _{DD}	Supply Voltage. +2.7V to +5.5V input power pin.

Table 1. DS1626/DS1726 REGISTER SUMMARY

REGISTER NAME (USER ACCESS)	SIZE	MEMORY TYPE	REGISTER CONTENTS AND POWER-UP/POR STATE
Temperature (Read Only)	12 Bits	SRAM	Measured Temperature (Two's Complement) Power-Up/POR State: -60°C (1100 0100 0000)
T _H (Read/Write)	12 Bits	EEPROM	Upper Alarm Trip Point (Two's Complement) Power-Up/POR State: User Defined Initial State from Factory: +15°C (0000 1111 0000)
T _L (Read/Write)	12 Bits	EEPROM	Lower Alarm Trip Point (Two's Complement) Power-Up/POR State: User Defined Initial State from Factory: +10°C (0000 1010 0000)
Configuration (Various Bits are Read/Write and Read Only—See Table 3)	1 Byte	SRAM and EEPROM	Configuration and Status Information (Unsigned) 4MSbs = SRAM and 4LSbs = EEPROM Power-Up/POR State: 1000XXXX (XXXX = User Defined)

Figure 1. DS1626/DS1726 FUNCTIONAL DIAGRAM

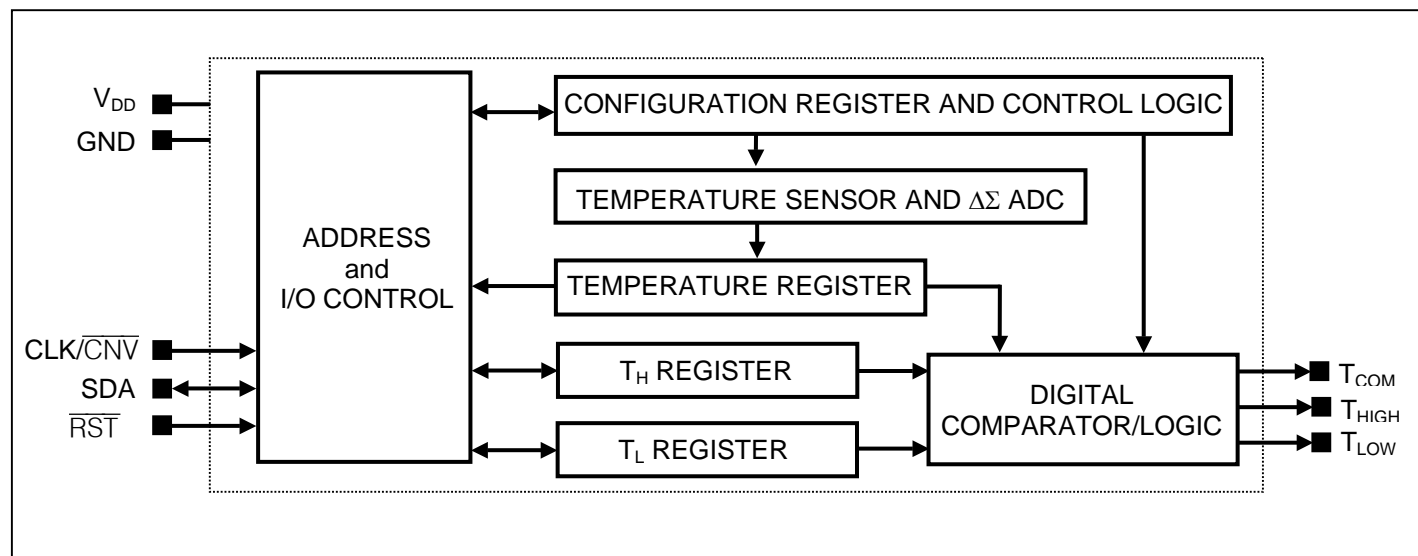

ABSOLUTE MAXIMUM RATINGS

Voltage Range on Any Pin Relative to Ground.....	-0.5V to +6.0V
Operating Temperature Range.....	-55°C to +125°C
Storage Temperature Range	-55°C to +125°C
Solder Dip Temperature (10s)	+260°C
Reflow Oven Temperature	+220°C

These are stress ratings only and functional operation of the device at these or any other conditions above those indicated in the operation sections of this specification is not implied. Exposure to absolute maximum rating conditions for extended periods of time may affect reliability.

DC ELECTRICAL CHARACTERISTICS

($V_{DD} = 2.7V$ to $5.5V$, $T_A = -55^\circ C$ to $+125^\circ C$.)

PARAMETER	SYMBOL	CONDITIONS	MIN	TYP	MAX	UNITS
Supply Voltage	V_{DD}	(Note 1)	2.7		5.5	V
DS1626 Thermometer Error (Note 2)	T_{ERR}	$0^\circ C$ to $+70^\circ C$, $3.0V \leq V_{DD} \leq 5.5V$			± 0.5	$^\circ C$
		$0^\circ C$ to $+70^\circ C$, $2.7V \leq V_{DD} < 3.0V$			± 1.25	
		$-55^\circ C$ to $+125^\circ C$			± 2	
DS1726 Thermometer Error (Note 2)	T_{ERR}	$-10^\circ C$ to $+85^\circ C$, $3.0V \leq V_{DD} \leq 5.5V$			± 1	$^\circ C$
		$-10^\circ C$ to $+85^\circ C$, $2.7V \leq V_{DD} < 3.0V$			± 1.5	
		$-55^\circ C$ to $+125^\circ C$			± 2	
Low-Level Input Voltage	V_{IL}	(Note 1)	-0.5		$0.3 \times V_{DD}$	V
High-Level Input Voltage	V_{IH}	(Note 1)	$0.7 \times V_{DD}$		$V_{DD} + 0.3$	V
Input Current each Input Pin		$0.4 < V_{IO} < 0.9 \times V_{DD}$	-10		+10	μA
Active Supply Current (Note 3)	I_{DD}	Temperature conversion $-55^\circ C$ to $+85^\circ C$			1	mA
		Temperature conversion $+85^\circ C$ to $+125^\circ C$			1.25	
		E^2 write				400
Input Resistance	R_I	\overline{RST} to GND DQ, CLK to V_{DD}	1			$M\Omega$
Standby Supply Current	I_{STBY}	$0^\circ C$ to $+70^\circ C$ (Note 3)			1.5	μA
THIGH, TLOW, TCOM, DQ Output Logic Voltages (Note 1)	V_{OH}	1mA source current	2.4			V
	V_{OL}	4mA sink current			0.4	
Thermal Drift		(Note 4)		± 0.2		$^\circ C$

EEPROM AC ELECTRICAL CHARACTERISTICS

($V_{DD} = 2.7V$ to $5.5V$, $T_A = -55^{\circ}C$ to $+125^{\circ}C$.)

PARAMETER	SYMBOL	CONDITIONS	MIN	TYP	MAX	UNITS
EEPROM Write Cycle Time	t_{wr}			4	10	ms
EEPROM Writes	N_{EEWR}	$-55^{\circ}C$ to $+55^{\circ}C$	50k			Writes
EEPROM Data Retention	t_{EEDR}	$-55^{\circ}C$ to $+55^{\circ}C$	10			Years

AC ELECTRICAL CHARACTERISTICS

($V_{DD} = 2.7V$ to $5.5V$, $T_A = -55^{\circ}C$ to $+125^{\circ}C$.)

PARAMETER	SYMBOL	CONDITIONS	MIN	TYP	MAX	UNITS
Temperature Conversion Time	t_{TC}	9 bits			93.75	ms
		10 bits			187.5	
		11 bits			375	
		12 bits			750	
Data In to Clock Setup	t_{DC}	(Note 5)	35			ns
Clock to Data In Hold	t_{CDH}	(Note 5)	40			ns
Clock to Data Out Delay	t_{CDD}	(Notes 5, 6)			150	ns
Clock Low/High Time	t_{CL}, t_{CH}	(Note 5)	285			ns
Clock Frequency	f_{CLK}	(Note 5)	0		1.75	MHz
Clock Rise/Fall Time	t_R, t_F	(Note 5)			500	ns
\overline{RST} to Clock Setup	t_{RC}	(Note 5)	100			ns
Clock to \overline{RST} Hold	t_{CRH}	(Note 5)	40			ns
\overline{RST} Inactive Time	t_{RI}	(Note 7)	125			ns
Clock High to I/O Hi-Z	t_{CDZ}	(Note 5)			50	ns
\overline{RST} Low to I/O Hi-Z	t_{RDZ}	(Note 5)			50	ns
\overline{CNV} Pulse Width	t_{CNV}	(Note 8)	250ns		500ms	
I/O Capacitance	$C_{I/O}$			10		pF
Input Capacitance	C_I			5		pF

NOTES:

- 1) All voltages are referenced to ground.
- 2) See Figure 2 for *TYPICAL OPERATING CURVES*.
- 3) I_{STBY} , I_{DD} specified with $DQ, CLK/\overline{CNV} = V_{DD}$ and $\overline{RST} = GND$.
- 4) Drift data is based on a 1000hr stress test at $+125^{\circ}C$ with $V_{DD} = 5.5V$.
- 5) See Timing Diagrams in Figure 3. All timing is referenced to $0.7 \times V_{DD}$ and $0.3 \times V_{DD}$.
- 6) Load capacitance = 50pF.
- 7) t_{RI} must be 10ms minimum following any write command that involves the E^2 memory.
- 8) 250ns is the guaranteed minimum pulse width for a conversion to start, however, a smaller pulse width may start a conversion.

Figure 2. TYPICAL OPERATING CURVES

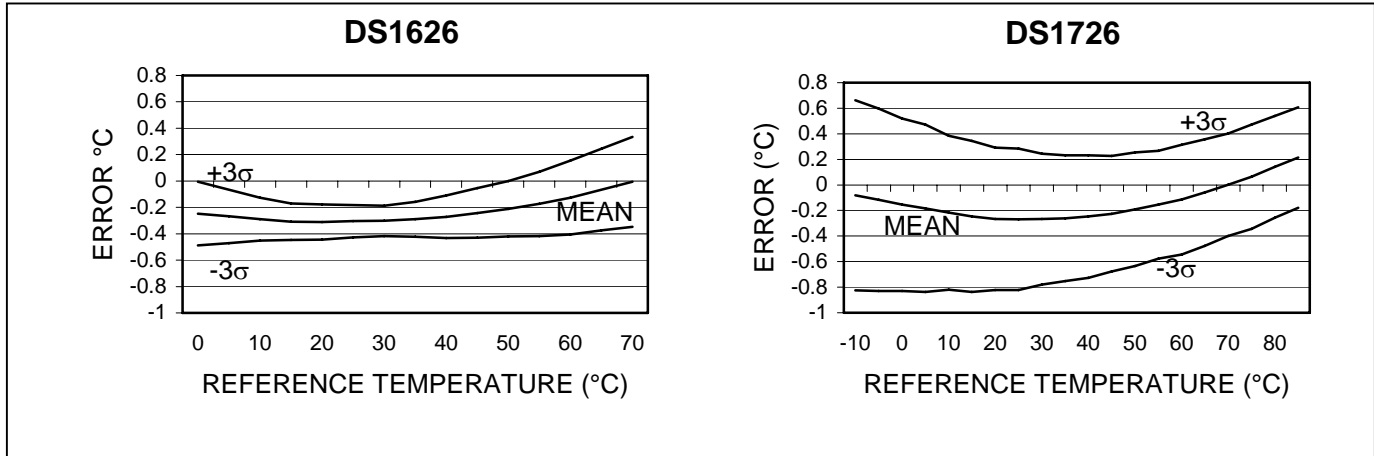
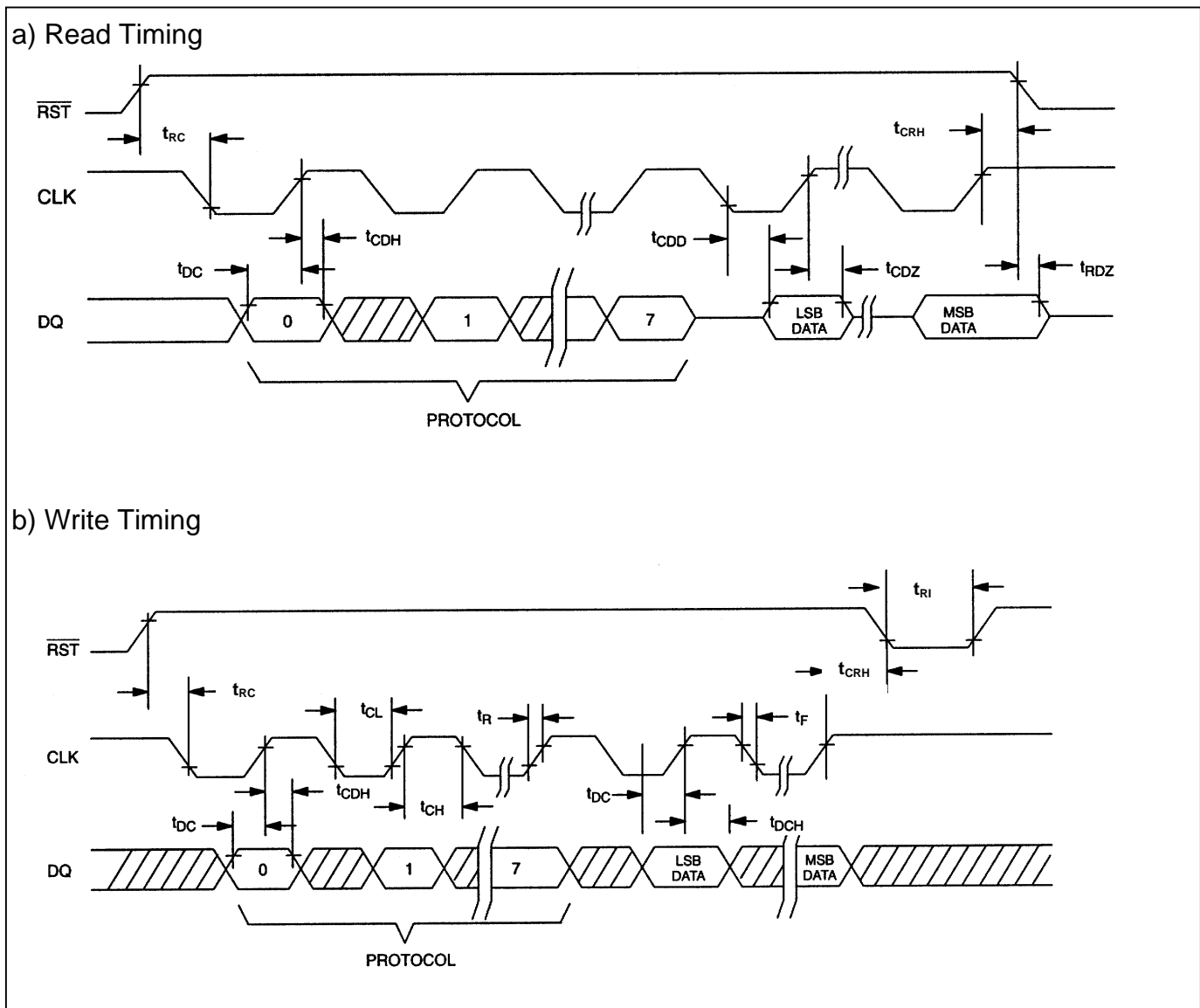

Figure 3. TIMING DIAGRAMS



OPERATION—MEASURING TEMPERATURE

The DS1626/DS1726 measure temperature using a bandgap-based temperature sensor. A delta-sigma analog-to-digital converter (ADC) converts the measured temperature to a digital value that is calibrated in degrees Celsius; for Fahrenheit applications a lookup table or conversion routine must be used. Communication with the DS1626/DS1726 is achieved through a 3-wire serial interface, and all data is transmitted LSb first.

The DS1626/DS1726 can be programmed to take continuous temperature measurements (continuous conversion mode) or to take single temperature measurements on command (one-shot mode). The measurement mode is programmed by the 1SHOT bit in the configuration register as explained in the *CONFIGURATION REGISTER* section of this data sheet. The 1SHOT bit is stored in EEPROM, so it can be programmed prior to installation if desired. In continuous conversion mode, when a Start Convert T command is issued the DS1626/DS1726 perform consecutive temperature measurements until a Stop Convert T command is issued. In one-shot mode, the Start Convert T command causes one temperature measurement to be taken and then the DS1626/DS1726 return to a low-power idle state.

The resolution of the DS1626/DS1726 digital temperature data is user-configurable to 9, 10, 11, or 12 bits, corresponding to temperature increments of 0.5°C, 0.25°C, 0.125°C, and 0.0625°C, respectively. The resolution is set by the EEPROM R0 and R1 bits in the configuration register. Note that the conversion time doubles for each additional bit of resolution.

After each temperature measurement and analog-to-digital conversion, the DS1626/DS1726 store the measured temperature as a two's complement number in the 12-bit temperature register (see Figure 4). The sign bit (S) indicates if the temperature is positive or negative: for positive numbers $S = 0$ and for negative numbers $S = 1$. The Read Temperature command provides user access to the temperature register.

When the DS1626/DS1726 are configured for 12-bit resolution, all 12 bits of the temperature register will contain temperature data. For 11-bit resolution, the 11 MSBs (bits 11 through 1) of the temperature register will contain data and bit 0 will read out as 0. Likewise, for 10-bit resolution, the 10 MSBs (bits 11 through 2) will contain data, and for 9-bit the 9 MSBs (bits 11 through 3) will contain data, and all unused LSbs will contain 0s. Since the DS1626/DS1726 transmit data LSb first, when reading data from the temperature register, all 12 bits must be read in order to receive all MSBs of the measured data, regardless of the conversion resolution. Table 2 gives examples of 12-bit resolution digital output data and the corresponding temperatures.

Figure 4. TEMPERATURE, T_H , and T_L REGISTER FORMAT

BIT 11	BIT 10	BIT 9	BIT 8	BIT 7	BIT 6	BIT 5	BIT 4	BIT 3	BIT 2	BIT 1	BIT 0
S	2^6	2^5	2^4	2^3	2^2	2^1	2^0	2^{-1}	2^{-2}	2^{-3}	2^{-4}

Table 2. 12-BIT RESOLUTION TEMPERATURE/DATA RELATIONSHIP

TEMPERATURE (°C)	DIGITAL OUTPUT (BINARY)	DIGITAL OUTPUT (HEX)
+125	0111 1101 0000	7D0h
+25.0625	0001 1001 0001	191h
+10.125	0000 1010 0010	0A2h
+0.5	0000 0000 1000	008h
0	0000 0000 0000	000h
-0.5	1111 1111 1000	FF8h
-10.125	1111 0101 1110	F5Eh
-25.0625	1110 0110 1111	E6Fh
-55	1100 1001 0000	C90h

OPERATION—THERMOSTAT FUNCTION

The DS1626/DS1726 thermostat outputs (T_{HIGH} , T_{LOW} , and T_{COM}) are updated after every temperature conversion and remain at the updated values until the next conversion completes. T_{HIGH} is asserted when the measured temperature is higher than or equal to the value stored in the T_H register, and T_{LOW} is asserted when the temperature is equal to or falls below the value in the T_L register (see Figure 5). T_{COM} uses both T_H and T_L to provide programmable hysteresis: when the measured temperature equals or exceeds T_H , T_{COM} is asserted and it remains asserted until the temperature falls to a value equal to or below T_L . All three thermostat outputs are active-high outputs.

The Write TH and Write TL commands are used to program the 12-bit T_H and T_L registers with user-defined two's complement values. The MSb (bit 11) of each register contains the two's complement sign bit (S). For the T_{COM} thermostat output to function correctly, the T_L value must be less than the T_H value. Any unused LSBs in the T_H and T_L registers are forced to 0 regardless of the data written to those bits. The unused LSBs are determined by the conversion resolution set by R1 and R0 in the configuration register. Therefore, for 9-bit conversions bits 2 through 0 will be 0, for 10-bit conversions bit 1 and bit 0 will be 0, and for 11-bit conversions bit 0 will be 0. All bits are used for 12-bit conversions, so no bits are forced to 0. However, regardless of the conversion resolution, when writing to T_H or T_L at least 12 bits must be sent following the Write TH or Write TL commands. The reason is that data written to T_H and T_L is not saved to EEPROM until the DS1626/DS1726 have received 12 bits, so if the operation is terminated before 12 bits have been received, the data will be lost. Any additional bits sent after the first twelve are ignored (e.g., if two 8-bit words are written).

Another DS1626/DS1726 thermostat feature is the temperature-high flag (THF) and temperature-low flag (TLF) in the configuration register. These bits provide a record of whether the temperature has been greater than or equal to T_H or less than or equal to T_L at any time since the DS1626/DS1726 were powered up. If the temperature is greater than or equal to the T_H register value, the THF bit in the configuration register will be set to 1. If the temperature is less than or equal to the T_L register value, the TLF bit in the configuration register will be set to 1. Once THF and/or TLF has been set, it will remain set until the user overwrites it with a 0 or until the power is cycled.

CPU BIT AND STAND-ALONE THERMOSTAT OPERATION

In stand-alone thermostat mode, DS1626/DS1726 thermostat functionality can be used without requiring a microcontroller to start/stop temperature conversions. The CPU bit in the configuration register determines if stand-alone mode is enabled.

When CPU = 1 stand-alone mode is disabled, and the only way to start/stop temperature conversions is by using a microcontroller to transmit Start Convert T and Stop Convert T commands, respectively.

Stand-alone mode is enabled when CPU = 0. In this mode, when $\overline{\text{RST}} = 0$ the CLK/ $\overline{\text{CNV}}$ pin operates as a control signal to start and stop temperature measurements. Driving CLK/ $\overline{\text{CNV}}$ low initiates continuous temperature conversions that will continue until CLK/ $\overline{\text{CNV}}$ is brought high again. If the CLK/ $\overline{\text{CNV}}$ pin is driven low and then returned to a high state in less than 10ms, only one temperature conversion will be performed after which the DS1626/DS1726 will return to a low-power idle state (i.e., one-shot operation). Note that when stand-alone mode is enabled, the 1SHOT bit in the configuration register is ignored, and only the CLK/ $\overline{\text{CNV}}$ signal determines whether continuous or one-shot conversions take place.

Since T_H , T_L , and the CPU bit are stored in EEPROM, the DS1626/DS1726 can be preprogrammed for stand-alone operation. If desired, the CLK/ $\overline{\text{CNV}}$ and $\overline{\text{RST}}$ pin can be connected to GND so the DS1626/DS1726 will automatically begin taking temperature measurements at power-up

Normal bus communication with the DS1626/DS1726 can still take place in stand-alone mode when $\overline{\text{RST}} = 1$. When communication is initiated, stand-alone conversions are automatically halted. If during the bus communication continuous temperature conversions are started using the Start Convert T command, they can only be stopped by issuing a Stop Convert T command.

Figure 5. THERMOSTAT OUTPUT OPERATION

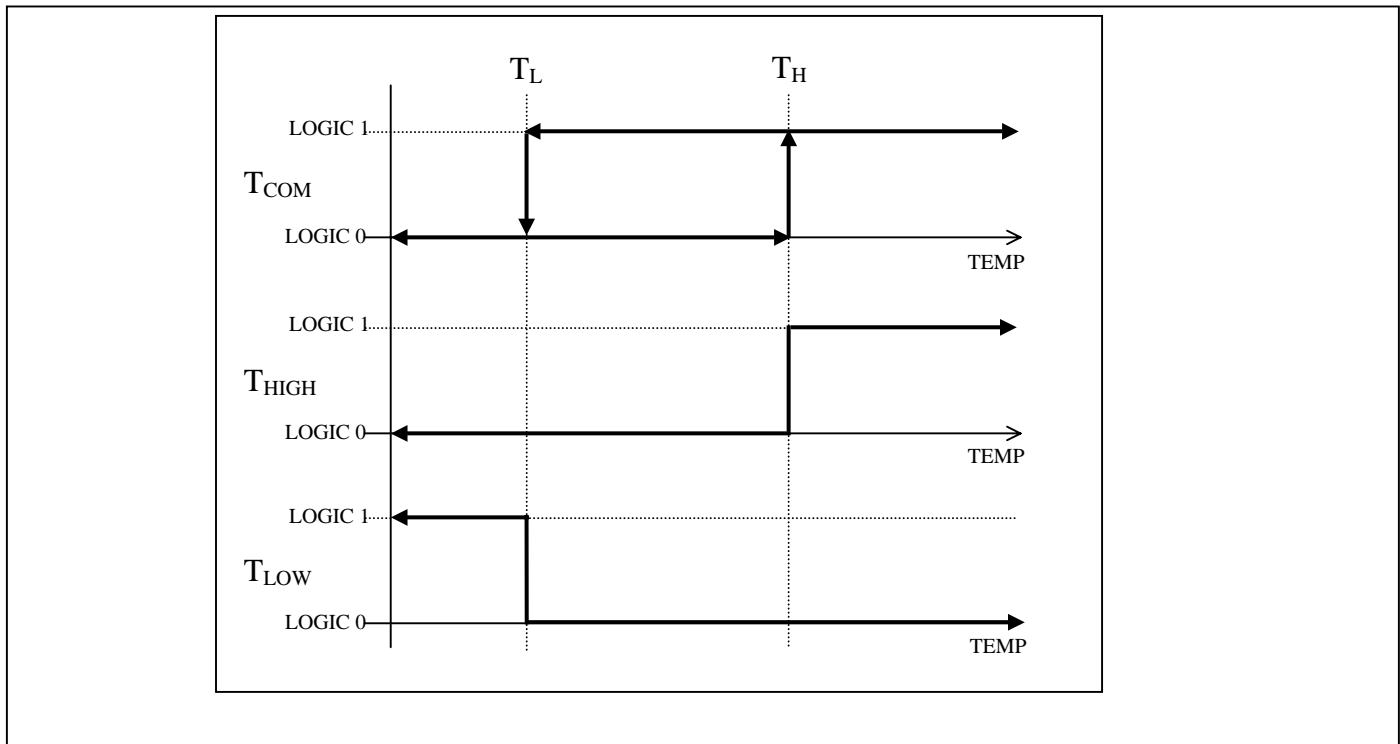

CONFIGURATION REGISTER

The configuration register allows the user to customize the DS1626/DS1726 conversion and thermostat options. It also provides information to the user about conversion status, EEPROM activity, and thermostat activity. The configuration register is arranged as shown in Figure 6 and detailed descriptions of each bit are provided in Table 3. This register can be accessed using the Read Config and Write Config commands. Note that the R1, R0, CPU, and 1SHOT bits are stored in EEPROM and all other configuration register bits are SRAM.

Figure 6. CONFIGURATION REGISTER

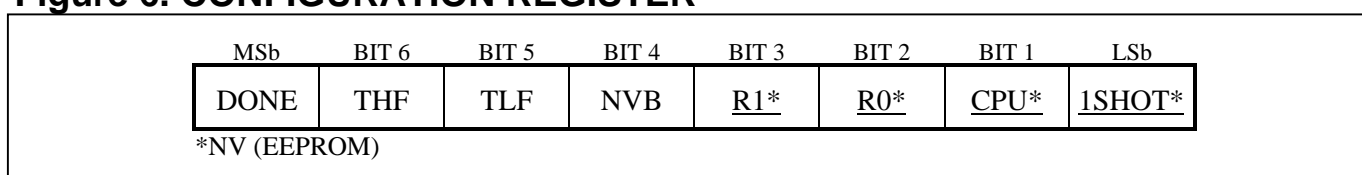

Table 3. CONFIGURATION REGISTER BIT DESCRIPTIONS

BIT NAME (USER ACCESS)	FUNCTIONAL DESCRIPTION
DONE (Read Only)	Power-up state = 1. DONE = 0. Temperature conversion is in progress. DONE = 1. Temperature conversion is complete.
THF (Read/Write)	Power-up state = 0. THF = 1. The measured temperature has reached or exceeded the value stored in the T _H register. THF will remain a 1 until it is overwritten with a 0 by the user, the power is cycled, or a Software POR command is issued.
TLF (Read/Write)	Power-up state = 0. TLF = 1. The measured temperature has equaled or dropped below the value stored in the T _L register. TLF will remain a 1 until it is overwritten with a 0 by the user, the power is cycled, or a Software POR command is issued.
NVB (Read Only)	Power-up state = 0. NVB = 1. Write to an E ² memory cell is in progress. NVB = 0. NV memory is not busy.
R1* (Read/Write)	Power-up state = last value written to this bit. Sets conversion resolution (see Table 4). Initial state from factory = 1.
R0* (Read/Write)	Power-up state = last value written to this bit. Sets conversion resolution (see Table 4). Initial state from factory = 1.
CPU* (Read/Write)	Power-up state = last value written to this bit. CPU = 1. Stand-alone mode is disabled. CPU = 0. Stand-alone mode is enabled when $\overline{\text{RST}} = 0$. See <i>CPU BIT AND STAND-ALONE THERMOSTAT OPERATION</i> section for more information. Initial state from factory = 0.
1SHOT* (Read/Write)	Power-up state = last value written to this bit. 1SHOT = 1: One-Shot Mode. The Start Convert T command initiates a single temperature conversion and then the device goes into a low-power standby state. 1SHOT = 0: Continuous Conversion Mode. The Start Convert T command initiates continuous temperature conversions. Initial state from factory = 0.

*NV (EEPROM)

Table 4. RESOLUTION CONFIGURATION

R1	R0	RESOLUTION (BITS)	CONVERSION TIME (MAX) (ms)
0	0	9	93.75
0	1	10	187.5
1	0	11	375
1	1	12	750

3-WIRE SERIAL DATA BUS

The 3-wire bus consists of three signals: $\overline{\text{RST}}$ (active-low reset), CLK (clock), and DQ (data). 3-wire communication is controlled by the $\overline{\text{RST}}$ signal, which functions as “chip select” signal. All data is transferred LSb first over the 3-wire bus. All communication with the DS1626/DS1726 is initiated by driving $\overline{\text{RST}}$ high. Driving $\overline{\text{RST}}$ low terminates communications and causes DQ to go to a high-impedance state. Note that $\overline{\text{RST}}$ must be toggled low after every communication sequence to ensure that subsequent commands are recognized by the DS1626/DS1726.

When writing to the DS1626/DS1726, data must be valid during the rising edge of CLK. During read operations the DS1626/DS1726 output data on DQ on the falling edge of CLK and the data remains valid through the following rising edge, at which time the DQ pin becomes high impedance until the next falling edge.

To communicate with the DS1626/DS1726, the master must first drive $\overline{\text{RST}}$ high and then begin generating the CLK signal while transmitting the desired DS1626/DS1726 command byte. If the command is a Start Convert T, Stop Convert T, or Software POR command, the transaction is finished when the last bit of the command has been sent. Figure 7a illustrates a Start Convert T command sequence.

When writing to the DS1626/DS1726, the master must begin transmitting data during the clock cycle immediately following the command byte. The DS1626/DS1726 will save only the number of data bits needed for the specific transaction. For example, for the Write TH or Write TL commands, after twelve bits of data have been transmitted by the master, the DS1626/DS1726 will ignore any subsequent data transmitted before $\overline{\text{RST}}$ goes low. Thus, if data is being transmitted in byte-length segments, the DS1626/DS1726 will load the first twelve bits into the T_H/T_L register, and the next four bits will be ignored. On the other hand, it is necessary to transmit at least the required number of bits for the requested transaction (i.e., 12-bits to T_H/T_L or 8-bits to the configuration register), because the DS1626/DS1726 will not save data until the expected number of bits have been received. Write TH and Write TL sequences are illustrated in Figure 7b and a Write Config sequence is shown in Figure 7c. Note that these figures assume byte-wide data transfers.

When reading data from the DS1626/DS1726, the DS1626/DS1726 will begin sending data during the clock cycle immediately following the command byte. After the last data byte has been sent, the DS1626/DS1726 will transmit a 0 during each subsequent clock until $\overline{\text{RST}}$ goes low. Figure 7d illustrates a Read Temperature sequence and a Read Config transaction is shown in Figure 7e. The sequence for reading the T_H or T_L registers is the same as the Read Temp transaction in Figure 7d except that the Read TH or Read TL command is used.

Figure 7. 3-WIRE COMMUNICATION

a) Start Temperature Conversion

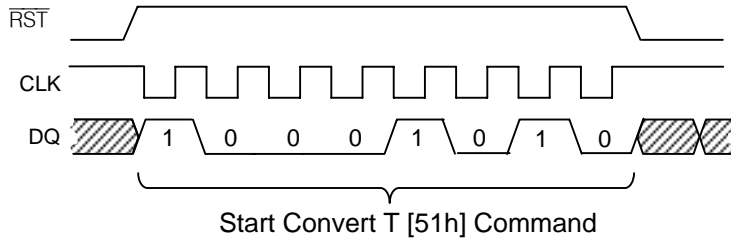

b) Write to the T_H/T_L Registers

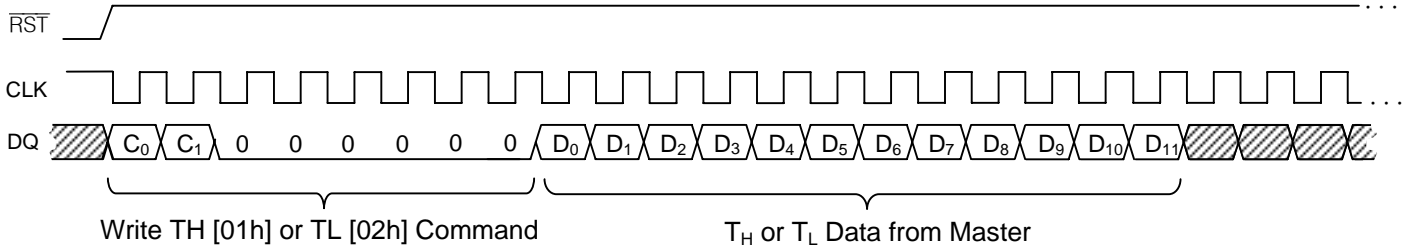

c) Write to the Configuration Register

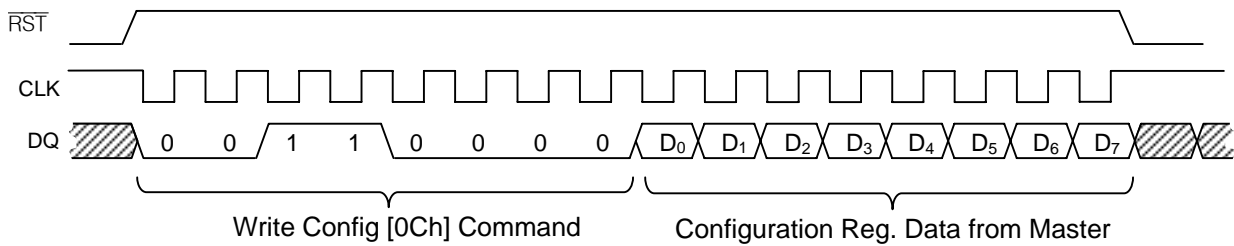

d) Read from the Temperature Register

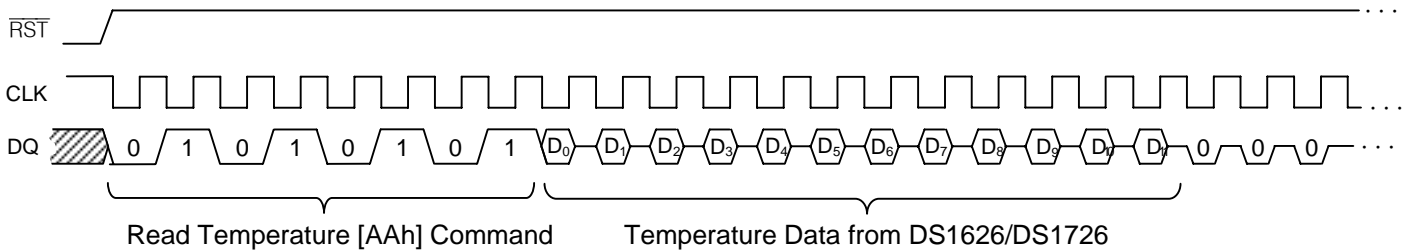

e) Read from the Configuration Register

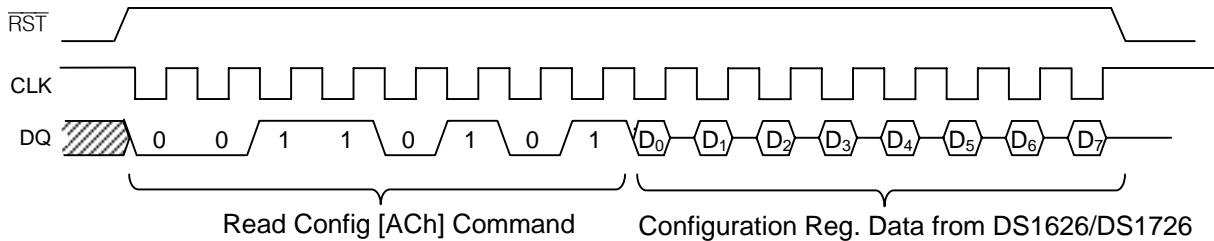

DS1626/DS1726 COMMAND SET

The DS1626/DS1726 command set is detailed below:

Start Convert T **51h** **0101 0001**

Initiates temperature conversions. If the DS1626/DS1726 are in one-shot mode (1SHOT = 1), only one conversion will be performed. If the devices are in continuous mode (1SHOT = 0), continuous conversions will be performed until a Stop Convert T command is issued.

Stop Convert T **22h** **0010 0010**

Stops temperature conversions when the devices are in continuous conversion mode (1SHOT = 0).

Read Temperature **AAh** **1010 1010**

Reads the last converted temperature value from the temperature register.

Read TH **A1h** **1010 0001**

Reads the 12-bit T_H register.

Read TL **A2h** **1010 0010**

Reads the 12-bit T_L register.

Write TH* **01h** **0000 0001**

Writes the 12-bit T_H register.

Write TL* **02h** **0000 0010**

Writes the 12-bit T_L register.

Read Config **ACh** **1010 1100**

Reads the 1-byte configuration register.

Write Config* **0Ch** **0000 1100**

Writes the 1-byte configuration register.

Software POR **54h** **0101 0100**

Initiates a software power-on reset (POR), which stops temperature conversions and resets all registers and logic to their power-up states. The software POR allows the user to simulate cycling the power without actually powering down the device.

**After issuing a write command, no further writes should be requested for at least 10ms due to the EEPROM write cycle time.*

PACKAGE INFORMATION

For the latest package outline information, go to www.maxim-ic.com/packages.

PACKAGE TYPE	PACKAGE CODE	DOCUMENT NO.
8 μ SOP	—	21-0036

Компания «Океан Электроники» предлагает заключение долгосрочных отношений при поставках импортных электронных компонентов на взаимовыгодных условиях!

Наши преимущества:

- Поставка оригинальных импортных электронных компонентов напрямую с производств Америки, Европы и Азии, а так же с крупнейших складов мира;
- Широкая линейка поставок активных и пассивных импортных электронных компонентов (более 30 млн. наименований);
- Поставка сложных, дефицитных, либо снятых с производства позиций;
- Оперативные сроки поставки под заказ (от 5 рабочих дней);
- Экспресс доставка в любую точку России;
- Помощь Конструкторского Отдела и консультации квалифицированных инженеров;
- Техническая поддержка проекта, помощь в подборе аналогов, поставка прототипов;
- Поставка электронных компонентов под контролем ВП;
- Система менеджмента качества сертифицирована по Международному стандарту ISO 9001;
- При необходимости вся продукция военного и аэрокосмического назначения проходит испытания и сертификацию в лаборатории (по согласованию с заказчиком);
- Поставка специализированных компонентов военного и аэрокосмического уровня качества (Xilinx, Altera, Analog Devices, Intersil, Interpoint, Microsemi, Actel, Aeroflex, Peregrine, VPT, Syfer, Eurofarad, Texas Instruments, MS Kennedy, Miteq, Cobham, E2V, MA-COM, Hittite, Mini-Circuits, General Dynamics и др.);

Компания «Океан Электроники» является официальным дистрибьютором и эксклюзивным представителем в России одного из крупнейших производителей разъемов военного и аэрокосмического назначения «JONHON», а так же официальным дистрибьютором и эксклюзивным представителем в России производителя высокотехнологичных и надежных решений для передачи СВЧ сигналов «FORSTAR».



JONHON

«JONHON» (основан в 1970 г.)

Разъемы специального, военного и аэрокосмического назначения:

(Применяются в военной, авиационной, аэрокосмической, морской, железнодорожной, горно- и нефтедобывающей отраслях промышленности)

«FORSTAR» (основан в 1998 г.)

ВЧ соединители, коаксиальные кабели,
кабельные сборки и микроволновые компоненты:

(Применяются в телекоммуникациях гражданского и специального назначения, в средствах связи, РЛС, а так же военной, авиационной и аэрокосмической отраслях промышленности).



Телефон: 8 (812) 309-75-97 (многоканальный)

Факс: 8 (812) 320-03-32

Электронная почта: ocean@oceanchips.ru

Web: <http://oceanchips.ru/>

Адрес: 198099, г. Санкт-Петербург, ул. Калинина, д. 2, корп. 4, лит. А