



CT300

2D Angular Sensor

Features

- Angular Error < 0.6° Over Full Temperature Range
- Dual Full-Bridge Resistor Network
- Operating Magnetic Field: 20 mT to 80 mT
- Differential Outputs for SIN and COS Axes
- Supply Voltage: 1.0 V to 5.5 V
- Package Options:
 - 8-lead TSSOP
 - 8-lead DFN, 2.00 × 2.00 × 0.45 mm
 - KGD (Known Good Die) in Wafer Form

Applications

- Angular Measurements
- Rotary and Angular Sensors
- BLDC Motors

Product Description

The CT300 is a 2D angular sensor in a dual full-bridge configuration from Crocus Technology developed on its patented MLU™ technology. The operating magnetic field for this 2D sensor is 20 mT to 80 mT and has an angular error of 0.6° after compensation over the full operating temperature range. It has differential outputs for both sine (SIN) and cosine (COS) axes and operates with a supply voltage range from 1.0 V to 5.5 V.

It is packaged in an 8-lead TSSOP package and for applications where space is critical, a low profile, small form factor 8-lead DFN package that is 2.00 × 2.00 × 0.45 mm in size. The CT300 is also made available in die form where it will be shipped as unsawn wafers (wafer map files will be provided to indicate known good die).

Ordering Information

Part Number	Operating Temperature Range	Output Type	Package	Packing Method
CT300LS-IT8	-40°C to +85°C	Differential	8-lead TSSOP 6.40 x 3.05 x 1.10 mm	Tape & Reel
CT300LS-HT8	-40°C to +125°C			
CT300LS-FT8	-40°C to +150°C			
CT300LS-ID8	-40°C to +85°C	Differential	8-lead DFN 2.00 x 2.00 x 0.45 mm	Tape & Reel
CT300LS-HD8	-40°C to +125°C			
CT300LS-FD8	-40°C to +150°C			
CT300LS-KGD	-40°C to +150°C	Differential	Wafer Form	Unsawn Wafer

Block Diagram

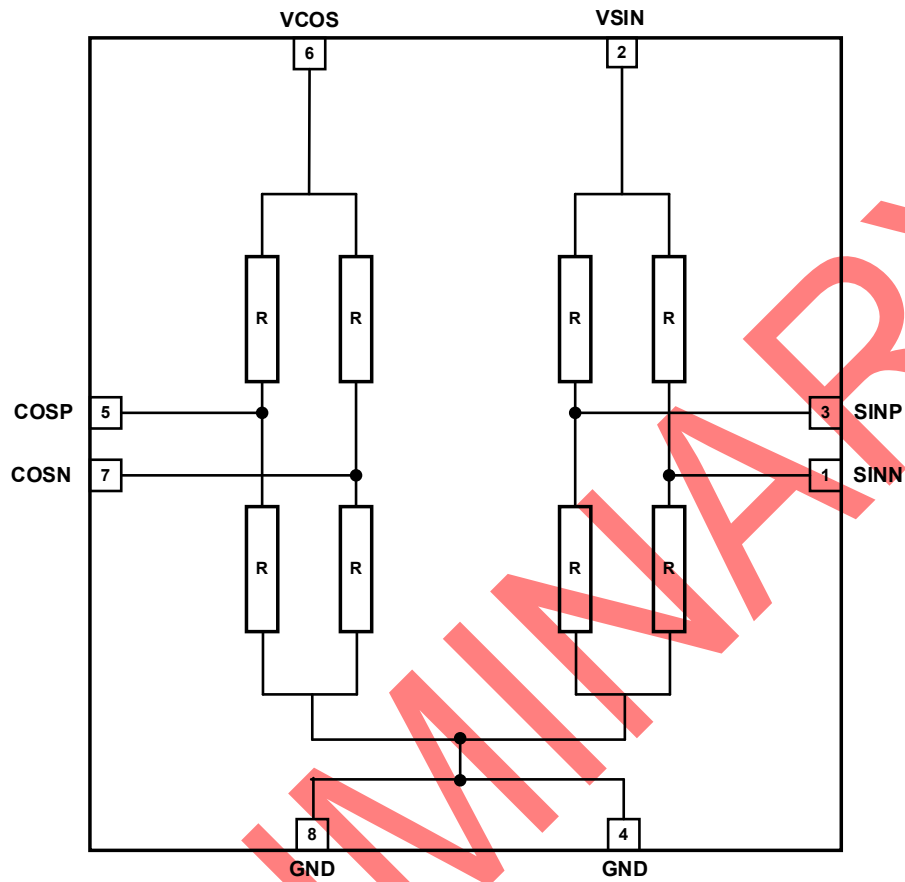

Figure 1. CT300 Functional Block Diagram

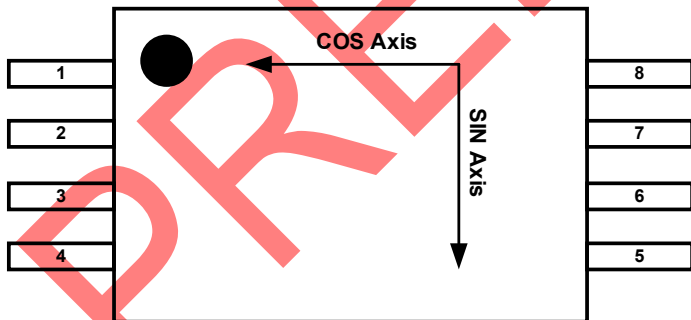

Figure 2. CT300 Axes of Sensitivity for TSSOP-8

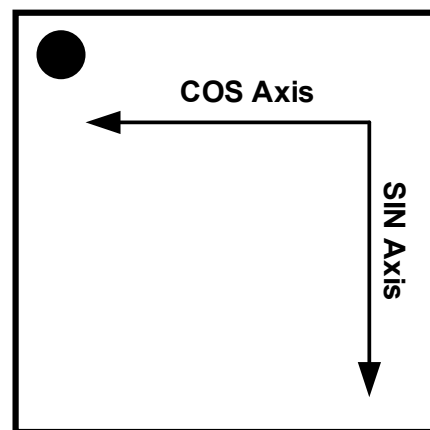
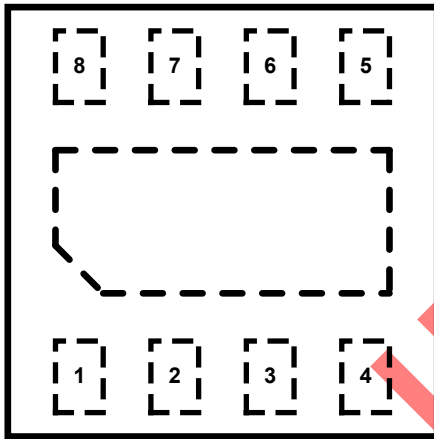

Figure 3. CT300 Axes of Sensitivity for DFN-8

Pin Configurations



TSSOP-8 – Top Down View



DFN-8 – Top Down View

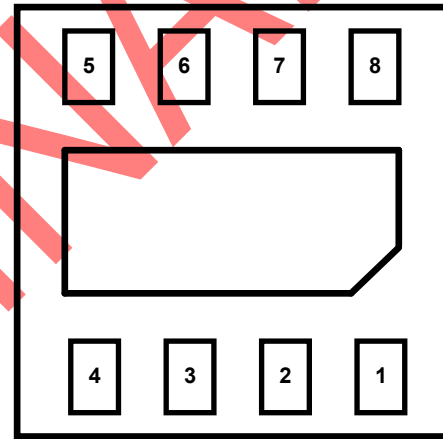

DFN-8 – Bottoms Up View

Figure 4. CT300 Pin-out Diagrams

Pin Definitions

TSSOP-8 Pin #	DFN-8 Pin #	Pin Name	Pin Description
1	1	SINN	Differential negative output for sine.
2	2	VSIN	Supply voltage for sine
3	3	SINP	Differential positive output for sine.
4	4	GND	Ground for sine.
5	5	COSP	Differential positive output for cosine.
6	6	VCOS	Supply voltage for cosine
7	7	COSN	Differential negative output for cosine.
8	8	GND	Ground for cosine.

Pad Configuration

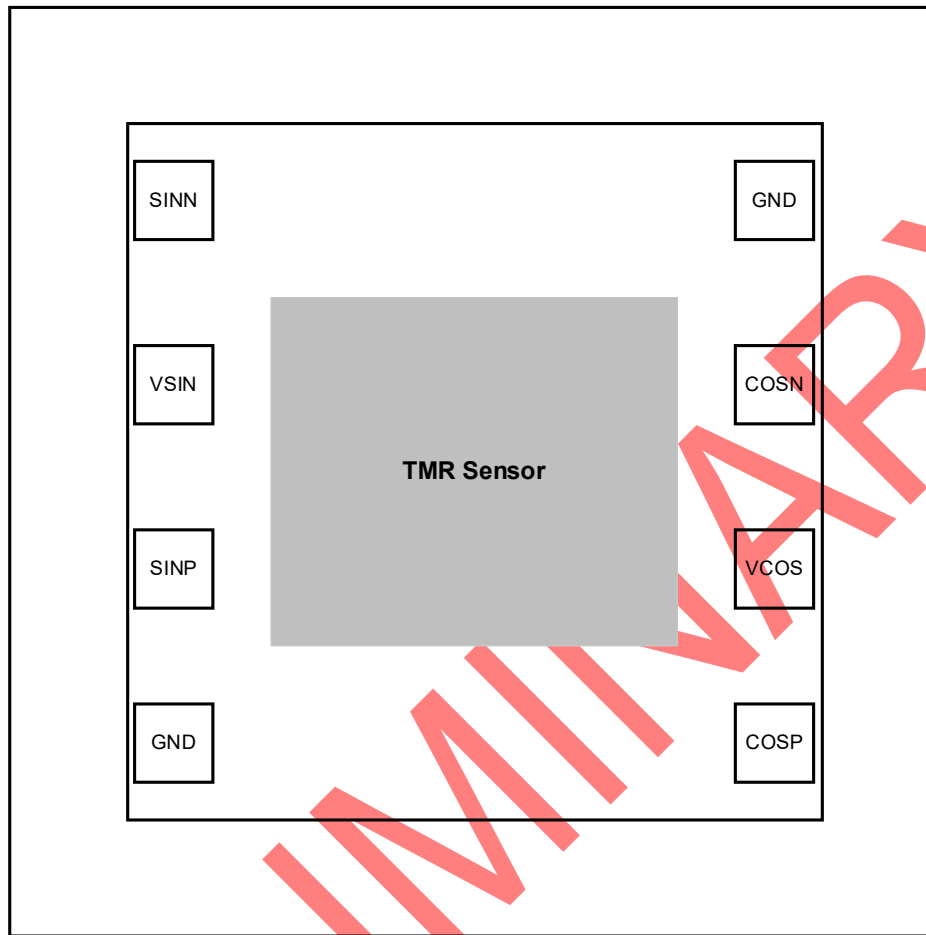

CT300 Die Layout
Top Down View

Figure 5. CT300 Pad Diagram

Pad Definitions

Pad #	Pad Name	Pad Description
1	SINN	Differential negative output for sine.
2	VSIN	Supply voltage for sine
3	SINP	Differential positive output for sine.
4	GND	Ground for sine.
5	COSP	Differential positive output for cosine.
6	VCOS	Supply voltage for cosine
7	COSN	Differential negative output for cosine.
8	GND	Ground for cosine.

Absolute Maximum Ratings

Stresses exceeding the absolute maximum ratings may damage the CT300 and may not function or be operable above the recommended operating conditions and stressing the parts to these levels is not recommended. In addition, extended exposure to stresses above the recommended operating conditions may affect device reliability. The absolute maximum ratings are stress ratings only.

Symbol	Parameter	Min.	Max.	Unit
V _{DD}	Supply Voltage	-0.3	6.0	V
V _{OUT}	Analog Output Pins Maximum Voltage	-1.50	+1.50	V
ESD	Electrostatic Discharge Protection Level	Human Body Model (HBM) per JESD22-A114	±4.0	kV
		Charged Device Model (CDM) per JESD22-C101	±1.0	
B _{MAX}	Maximum Magnetic Field		200	mT
T _{STG}	Storage Temperature	-65	+165	°C
T _L	Lead Soldering Temperature, 10 Seconds		+260	°C

Recommended Operating Conditions

The Recommended Operating Conditions table defines the conditions for actual operation of the CT300. Recommended operating conditions are specified to ensure optimal performance to the specifications. Crocus Technology does not recommend exceeding them or designing to absolute maximum ratings.

Symbol	Parameter	Min.	Typ.	Max.	Unit	
V _{DD}	Supply Voltage Range	1.0		5.5	V	
V _{OUT}	OUT Voltage Range	-1.30		+1.30	V	
B _{OPERATING}	Operating Magnetic Field	20		80	mT	
T _A	Operating Ambient Temperature	Industrial	-40	+25	+85	°C
		Extended Industrial	-40	+25	+125	
		Full	-40	+25	+150	

Thermal Properties

Junction-to-ambient thermal resistance is a function of application and board layout and is determined in accordance to JEDEC standard JESD51-7 for a four (4) layer 2s2p FR-4 printed circuit board (PCB) with 2 oz. of copper (Cu). Special attention must be paid to not exceed junction temperature T_{J(MAX)} at a given ambient temperature T_A.

Symbol	Parameter	Min.	Typ.	Max.	Unit
θ _{JA}	Junction-to-Ambient Thermal Resistance, DFN-8		81		°C/W
θ _{JA}	Junction-to-Ambient Thermal Resistance, TSSOP-8		124		°C/W

Electrical & Magnetic Specifications

Unless otherwise specified: $V_{DD} = 1.0\text{ V to }5.5\text{ V}$, $C_{BYP} = 0.1\ \mu\text{F}$ and $T_A = -40^\circ\text{C to }+150^\circ\text{C}$. Typical values are $V_{DD} = 3.0\text{ V}$ and $T_A = +25^\circ\text{C}$.

Symbol	Parameter	Conditions	Min.	Typ.	Max.	Units
Magnetic						
$B_{OPERATING}$	Operating Magnetic Field		20		80	mT
Electrical						
R_{BRIDGE}	Bridge Resistance	$T_A = +25^\circ\text{C}$	36	40	44	k Ω
Differential Outputs						
θ_{ERR}	Angular Error ⁽¹⁾	After Compensation (Offset Cancellation and Amplitude Normalization)			0.6	°
θ_{ERR_HYST}	Angle Error due to Hysteresis		No Hysteresis			°
V_{SIN_D} , V_{COS_D}	SIN, COS Differential Output Voltage Peak-to-Peak		0.38	0.40	0.47	V/V
V_{OFF_SIN} , V_{OFF_COS}	SIN, COS Voltage Offset			±1	±5	mV/V
k	SIN, COS Amplitude Synchronism Ratio		97	100	103	%
OE_{SIN} , OE_{COS}	SIN, COS Orthogonality Error		87	90	93	°
$t_{RESPONSE}$	SIN, COS Response Time	$C_L = 37\text{ pF}$		1.0		μs

(1) Hysteresis error and output noise are included in the Angular Error specification.

Electrical Characteristics

$V_{DD} = 3.0\text{ V}$ and $T_A = +25^\circ\text{C}$, $C_{BYP} = 0.1\ \mu\text{F}$.

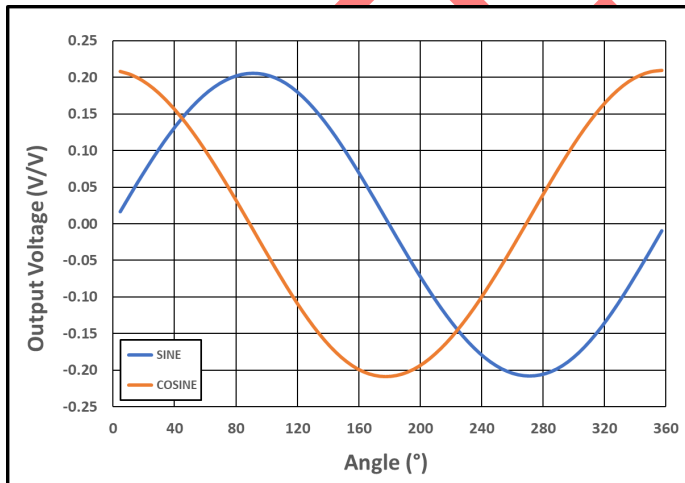

Figure 6. Output Voltage vs. Angle

Recommended Application Circuit

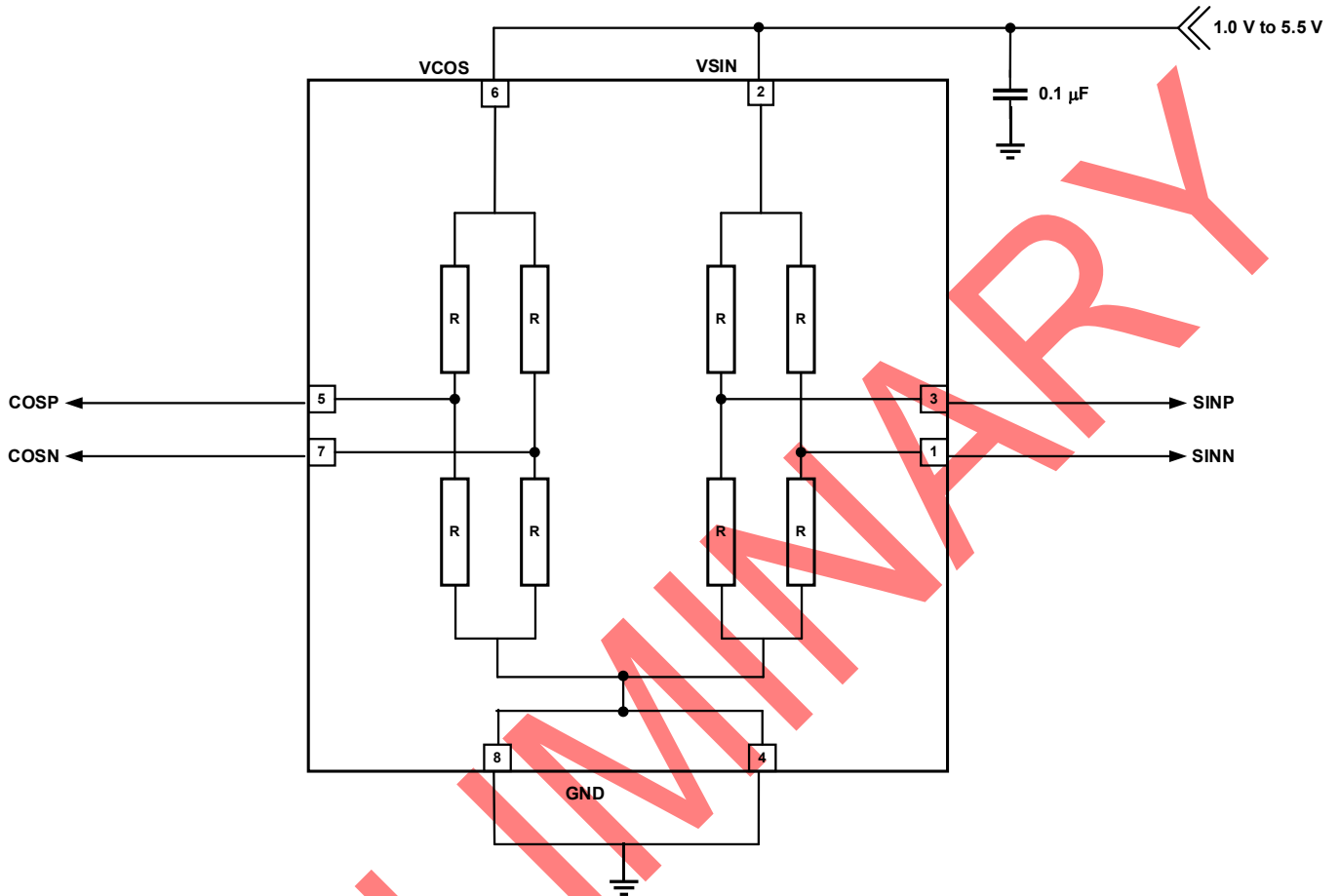

Figure 7. CT300 Application Diagram

Table 1. Recommended External Components

Component	Description	Vendor & Part Number	Parameter	Min.	Typ.	Max.	Unit
C _{BY}	0.1 μF, X7R	Murata GRM033Z71A104KE14	C		0.1		μF
		Others					

TSSOP-8 Package Drawing and Dimensions

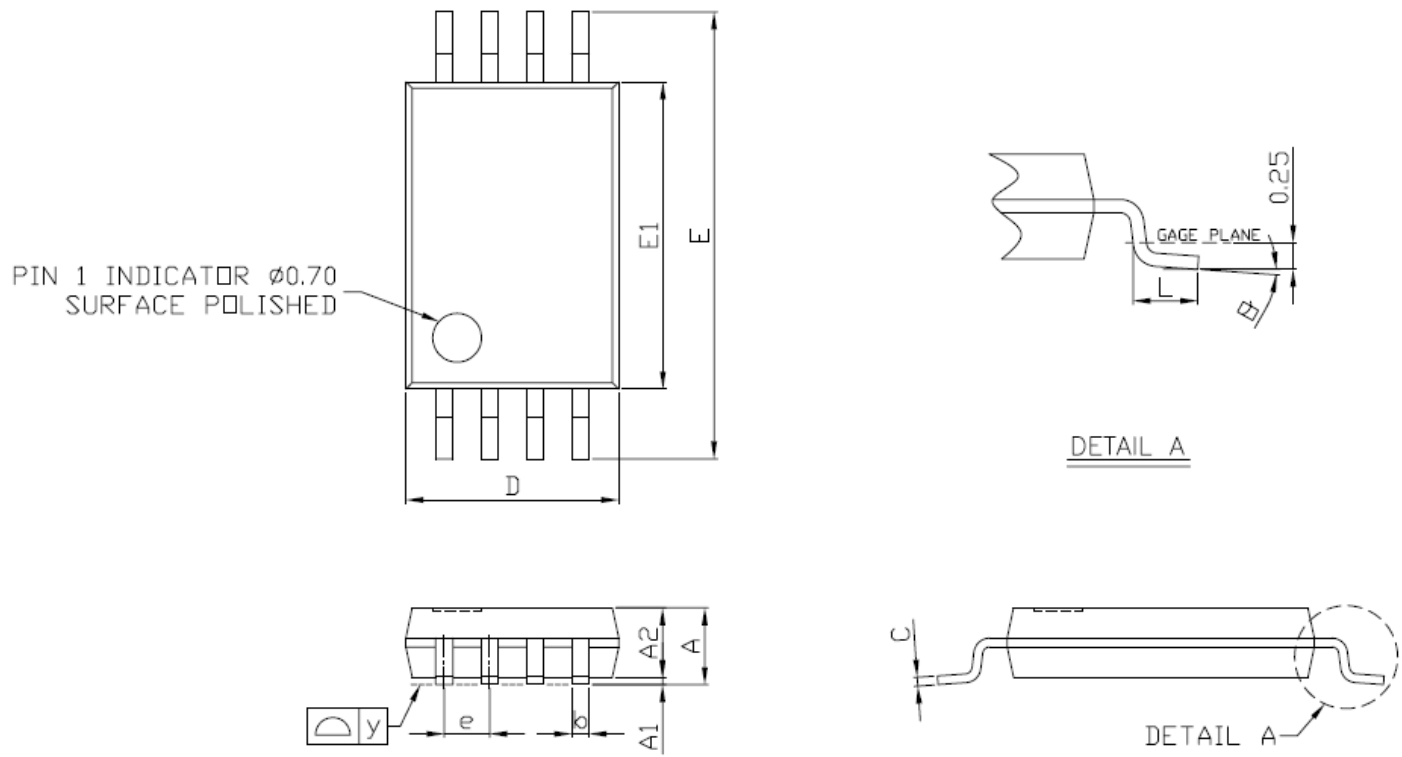

Figure 8. TSSOP-8 Package Drawing

Table 2. CT300 TSSOP-8 Package Dimensions

Symbol	Dimensions in Millimeters (mm)		
	Min.	Typ.	Max.
A	1.05	1.10	1.20
A1	0.05	0.10	0.15
A2	-	1.00	1.05
b	0.25	-	0.30
C	-	0.127	-
D	2.90	3.05	3.10
E	6.20	6.40	6.60
E1	4.30	4.40	4.50
e	-	0.65	-
L	0.50	0.60	0.70
y	-	-	0.076
θ	0°	4°	8°

Crocus Technology provides package drawings as a service to customers considering or planning to use Crocus products in their designs. Drawings may change without notice. Please note the revision and date of the data sheet and contact a Crocus Technology representative to verify or obtain the most recent version. The package specifications do not expand the terms of Crocus Technology's worldwide terms and conditions, specifically the warranty therein, which covers Crocus Technology's products.

DFN-8 Package Drawing and Dimensions

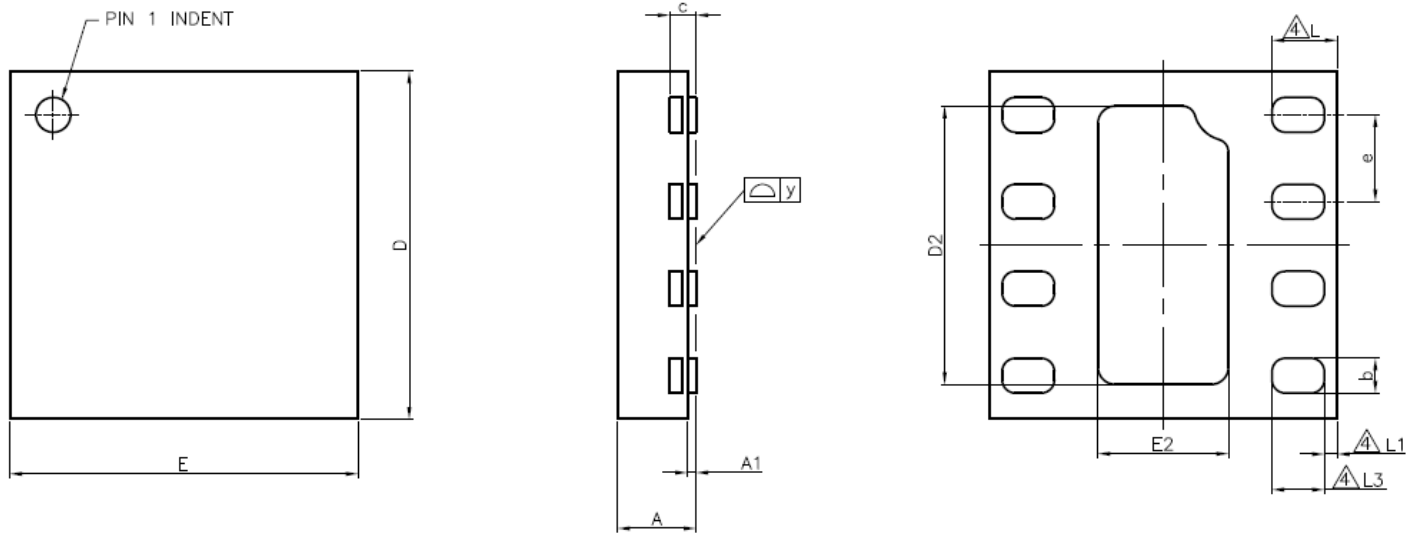

Note:

1. The terminal #1 identifier is a laser marked feature.

Figure 9. DFN-8 Package Drawing

Table 3. CT300 DFN-8 Package Dimensions

Symbol	Dimensions in Millimeters (mm)		
	Min.	Typ.	Max.
A	0.40	0.45	0.50
A1	0.00	0.02	0.05
b	0.15	0.20	0.25
c	-	0.150 REF	-
D	1.925	2.000	2.075
D2	1.550	1.600	1.650
E	1.925	2.000	2.075
E2	0.700	0.750	0.800
e	-	0.40	-
L	0.325	0.375	0.425
L1	-	0.075	-
L3	0.250	0.300	0.350
y	0.000	-	0.075

Crocus Technology provides package drawings as a service to customers considering or planning to use Crocus products in their designs. Drawings may change without notice. Please note the revision and date of the data sheet and contact a Crocus Technology representative to verify or obtain the most recent version. The package specifications do not expand the terms of Crocus Technology's worldwide terms and conditions, specifically the warranty therein, which covers Crocus Technology's products.

Package Information

Table 4. CT300 Package Information

Part Number	Package Type	# of Leads	Package Quantity	Lead Finish	Eco Plan ⁽¹⁾	MSL Rating ⁽²⁾	Operating Temperature ⁽³⁾	Device Marking
CT300LS-IT8	TSSOP	8	2,500	Sn	Green & RoHS	1	-40°C to +85°C	CT300LS-IT8 YYWWSS
CT300LS-HT8	TSSOP	8	2,500	Sn	Green & RoHS	1	-40°C to +125°C	CT300LS-HT8 YYWWSS
CT300LS-FT8	TSSOP	8	2,500	Sn	Green & RoHS	1	-40°C to +150°C	CT300LS-FT8 YYWWSS
CT300LS-ID8	DFN	8	3,000	Sn	Green & RoHS	1	-40°C to +85°C	300I YWWS
CT300LS-HD8	DFN	8	3,000	Sn	Green & RoHS	1	-40°C to +125°C	300H YWWS
CT300LS-FD8	DFN	8	3,000	Sn	Green & RoHS	1	-40°C to +150°C	300F YWWS

- (1) RoHS is defined as semiconductor products that are compliant to the current EU RoHS requirements. It also will meet the requirement that RoHS substances do not exceed 0.1% by weight in homogeneous materials. Green is defined as the content of Chlorine (Cl), Bromine (Br) and Antimony Trioxide based flame retardants satisfy JS709B low halogen requirements of $\leq 1,000$ ppm.
- (2) MSL Rating = Moisture Sensitivity Level Rating as defined by JEDEC standard classifications.
- (3) Package will withstand ambient temperature range of -40°C to +150°C and storage temperature range of -65°C to +165°C.
- (4) Device Marking for TSSOP is defined as CT300LS-XT8 YYWWSS where CT300LS = base part number, X = temperature code, T8 = TSSOP-8 package, YY = year, WW = work week and SS = sequential number. DFN is defined as 300X where X = temperature code and Y = year, WW = work week and S = sequential number.

Disclaimer: The contents of this document are provided for informational purposes only. CROCUS TECHNOLOGY, INC. AND CROCUS TECHNOLOGY SA (COLLECTIVELY "CROCUS") MAKE NO REPRESENTATIONS OR WARRANTY OF ANY KIND, EXPRESS OR IMPLIED, WITH RESPECT TO THE ACCURACY OR COMPLETENESS OF THE CONTENTS HEREIN, INCLUDING, BUT NOT LIMITED TO, THE IMPLIED WARRANTIES OF MERCHANTABILITY AND FITNESS FOR A PARTICULAR PURPOSE. Crocus reserves the right to make changes to the specifications and product descriptions, and/or to discontinue or make changes to its products at any time without notice. Crocus's products have not been designed, tested, or manufactured for use and should not be used in applications where the failure, malfunction or inaccuracy of the Products carries a risk of death or serious bodily injury or damage to tangible property, including, but not limited to, life support systems, nuclear facilities, military, aircraft navigation or communication, emergency systems, harsh environments, or other applications with a similar degree of potential hazard.

Product Status Definition

Data Sheet Identification	Product Status	Definition
Objective	Proposed New Product Idea or In Development	Data sheet contains design target specifications and are subject to change without notice at any time.
Preliminary	First Production	Data sheet contains preliminary specifications obtained by measurements of early samples. Follow-on data will be published at a later date as more test data is acquired. Crocus reserves the right to make changes to the data sheet at any time.
None	Full Production	Data sheet contains final specifications for all parameters. Crocus reserves the right to make changes to the data sheet at any time.
Obsolete	Not in Production	Data sheet for a product that is no longer in production at Crocus. It is for reference only.

Mouser Electronics

Authorized Distributor

Click to View Pricing, Inventory, Delivery & Lifecycle Information:

[Crocus Technology:](#)

[CT300LS-IT8](#)

Компания «Океан Электроники» предлагает заключение долгосрочных отношений при поставках импортных электронных компонентов на взаимовыгодных условиях!

Наши преимущества:

- Поставка оригинальных импортных электронных компонентов напрямую с производств Америки, Европы и Азии, а так же с крупнейших складов мира;
- Широкая линейка поставок активных и пассивных импортных электронных компонентов (более 30 млн. наименований);
- Поставка сложных, дефицитных, либо снятых с производства позиций;
- Оперативные сроки поставки под заказ (от 5 рабочих дней);
- Экспресс доставка в любую точку России;
- Помощь Конструкторского Отдела и консультации квалифицированных инженеров;
- Техническая поддержка проекта, помощь в подборе аналогов, поставка прототипов;
- Поставка электронных компонентов под контролем ВП;
- Система менеджмента качества сертифицирована по Международному стандарту ISO 9001;
- При необходимости вся продукция военного и аэрокосмического назначения проходит испытания и сертификацию в лаборатории (по согласованию с заказчиком);
- Поставка специализированных компонентов военного и аэрокосмического уровня качества (Xilinx, Altera, Analog Devices, Intersil, Interpoint, Microsemi, Actel, Aeroflex, Peregrine, VPT, Syfer, Eurofarad, Texas Instruments, MS Kennedy, Miteq, Cobham, E2V, MA-COM, Hittite, Mini-Circuits, General Dynamics и др.);

Компания «Океан Электроники» является официальным дистрибьютором и эксклюзивным представителем в России одного из крупнейших производителей разъемов военного и аэрокосмического назначения «JONHON», а так же официальным дистрибьютором и эксклюзивным представителем в России производителя высокотехнологичных и надежных решений для передачи СВЧ сигналов «FORSTAR».



JONHON

«JONHON» (основан в 1970 г.)

Разъемы специального, военного и аэрокосмического назначения:

(Применяются в военной, авиационной, аэрокосмической, морской, железнодорожной, горно- и нефтедобывающей отраслях промышленности)

«FORSTAR» (основан в 1998 г.)

ВЧ соединители, коаксиальные кабели, кабельные сборки и микроволновые компоненты:

(Применяются в телекоммуникациях гражданского и специального назначения, в средствах связи, РЛС, а так же военной, авиационной и аэрокосмической отраслях промышленности).



Телефон: 8 (812) 309-75-97 (многоканальный)

Факс: 8 (812) 320-03-32

Электронная почта: ocean@oceanchips.ru

Web: <http://oceanchips.ru/>

Адрес: 198099, г. Санкт-Петербург, ул. Калинина, д. 2, корп. 4, лит. А