

Digital Temperature Sensor IC

BH1900NUX

General Description

The BH1900NUX is a digital temperature sensor IC equipped with a two-wire serial interface. It's small package, so it can be placed near the component which temperature is measured. This device has 3 address pins and it allows to connect 8 devices on one bus.

Features

- Digital Output: Two-wire Serial Interface.
- 8 Addresses.
- Thermostat Mode.
- Small package.

Applications

- Smart phone, Tablet, LCD TV, notebook PC, portable game machine, and digital camera.

Key Specifications

- Supply Voltage Range: 2.7V to 3.6V
- Temperature Accuracy(-20°C to +85°C): ±3.0°C
- Operating Current: 75µA (Typ)
- Shutdown Current: 1µA (Typ)
- Operating Temperature Range: -30°C to +95°C

Package

VSON008X2030

W(Typ) x D(Typ) x H(Max)

2.00mm x 3.00mm x 0.60mm



Typical Application Circuit

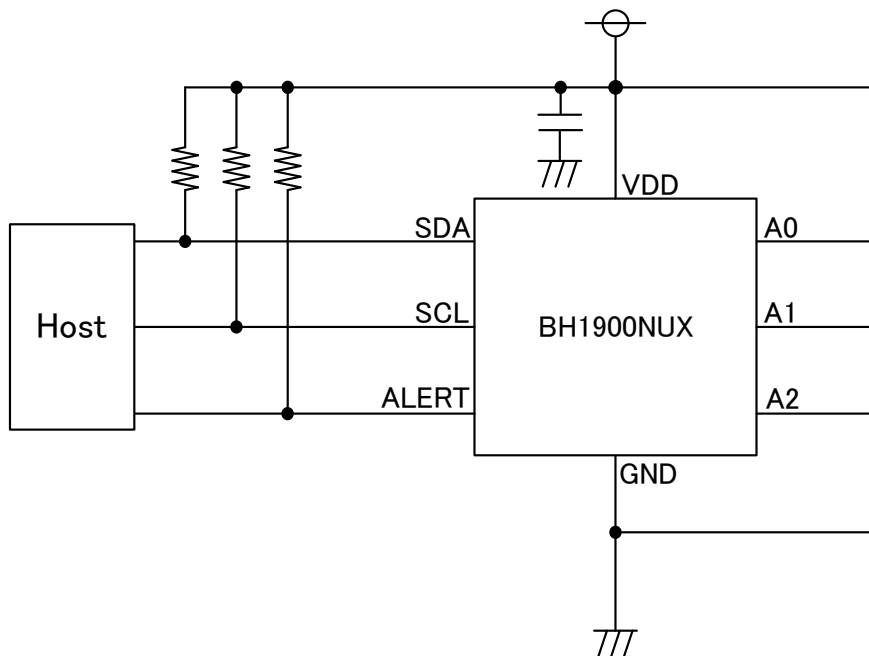

When address pins are A2=L, A1=L, A0=H.

Contents

General Description.....	1
Features.....	1
Applications	1
Key Specifications	1
Package	1
Typical Application Circuit.....	1
Pin Configuration.....	3
Pin Description	3
Block Diagram.....	3
Absolute Maximum Ratings.....	4
Thermal Resistance	4
Recommended Operating Conditions	5
Electrical Characteristics	5
Typical Performance Curves.....	6
Figure 1. Operating Current vs Ambient Temperature	6
Figure 2. Shutdown Current vs Ambient Temperature.....	6
Figure 3. Temperature Error vs Ambient Temperature.....	6
Two-wire Serial Interface Timing Characteristics	7
Two-wire Serial Communication.....	8
Register Map	9
Application Example	12
I/O equivalence circuit.....	13
Operational Notes	14
Ordering Information.....	16
Marking Diagrams.....	16
Physical Dimension, Tape and Reel Information	17
Revision History	18

Pin Configuration

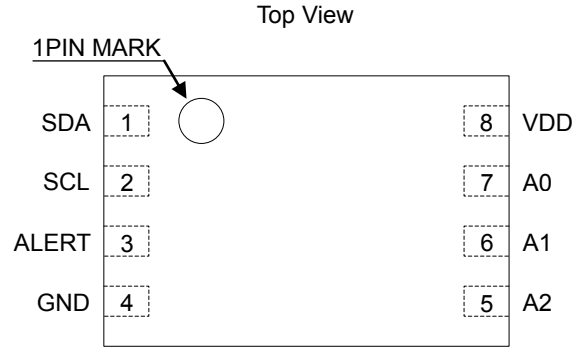

Pin Description

Pin No.	Pin Name	Function
1	SDA	Serial bus data
2	SCL	Serial bus clock
3	ALERT	Alert output
4	GND	Ground
5	A2	Address2
6	A1	Address1
7	A0	Address0
8	VDD	Power supply ^(Note 1)

(Note 1) Dispose a bypass capacitor as close as possible to the IC.

Block Diagram

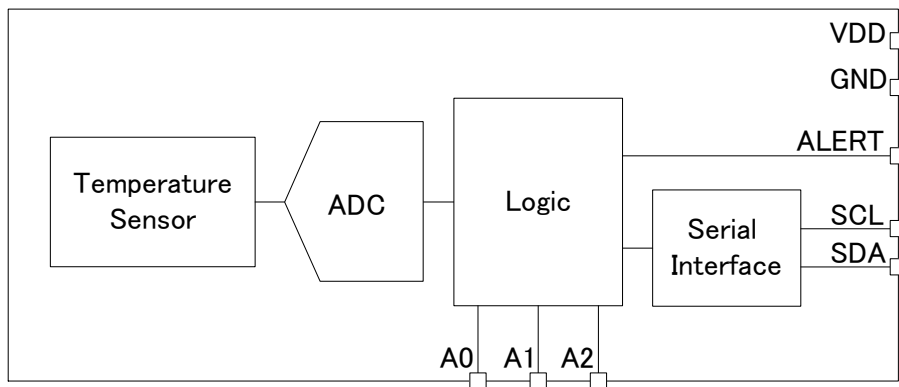

Absolute Maximum Ratings (Ta = 25°C)

Parameter	Symbol	Limits	Units
Supply Voltage	V _{DD_MR}	4.5	V
Input Voltage	V _{INMR}	-0.3 to (V _{DD} +0.3) or +4.5 Whichever is less	V
Operating Temperature Range	T _{opr}	-30 to +95	°C
Storage Temperature	T _{stg}	-40 to +125	°C
Maximum Junction Temperature	T _{jmax}	125	°C

Caution: Operating the IC over the absolute maximum ratings may damage the IC. The damage can either be a short circuit between pins or an open circuit between pins and the internal circuitry. Therefore, it is important to consider circuit protection measures, such as adding a fuse, in case the IC is operated over the absolute maximum ratings.

Thermal Resistance (Note 1)

Parameter	Symbol	Thermal Resistance (Typ)		Unit
		1s ^(Note 3)	2s2p ^(Note 4)	
VSON008X2030				
Junction to Ambient	θ_{JA}	308.3	69.9	°C/W
Junction to Top Characterization Parameter ^(Note 2)	Ψ_{JT}	43	10	°C/W

(Note 1) Based on JESD51-2A(Still-Air).

(Note 2) The thermal characterization parameter to report the difference between junction temperature and the temperature at the top center of the outside surface of the component package.

(Note 3) Using a PCB board based on JESD51-3.

Layer Number of Measurement Board	Material	Board Size
Single	FR-4	114.3mm x 76.2mm x 1.57mm

Top	
Copper Pattern	Thickness
Footprints and Traces	70μm

(Note 4) Using a PCB board based on JESD51-7.

Layer Number of Measurement Board	Material	Board Size
4 Layers	FR-4	114.3mm x 76.2mm x 1.6mm

Top		2 Internal Layers		Bottom	
Copper Pattern	Thickness	Copper Pattern	Thickness	Copper Pattern	Thickness
Footprints and Traces	70μm	74.2mm x 74.2mm	35μm	74.2mm x 74.2mm	70μm

Recommended Operating Conditions (Ta= -30°C to +95°C)

Parameter	Symbol	Min	Typ	Max	Units
Power Supply Voltage	V _{DD}	2.7	3.3	3.6	V

Electrical Characteristics (Unless otherwise specified V_{DD}=3.3V, Ta=25°C)

Parameter	Symbol	Min	Typ	Max	Units	Conditions
Temperature Accuracy	Et	-3.0	-	+3.0	°C	Ta=-20°C to +85°C
Resolution	R _{ES}	-	0.0625	-	°C/LSB	
Oscillator Frequency	F _{OSC}	470	750	-	kHz	
Conversion time	T _{AD}	-	22	35	ms	
Operating Current	I _{DD}	-	75	150	μA	In Non-communication
Shutdown Current	I _{SS}	-	1	5	μA	
L Input Voltage (SDA, SCL)	V _{IL}	-	-	0.54	V	
H Input Voltage (SDA, SCL)	V _{IH}	1.26	-	-	V	
L Input Voltage2 (A0, A1, A2)	V _{IL2}	-	-	0.3*V _{DD}	V	
H Input Voltage2 (A0, A1, A2)	V _{IH2}	0.7*V _{DD}	-	-	V	
Input Leakage Current	I _{IL}	-10	-	+10	μA	
Digital Output Voltage (SDA, ALERT)	V _{OL}	0	-	0.4	V	I _{OL} =3mA

Caution: A characteristic of the IC might change heating during reflow soldering. When high temperature accuracy is required, correction should be done after assembly.

Typical Performance Curves

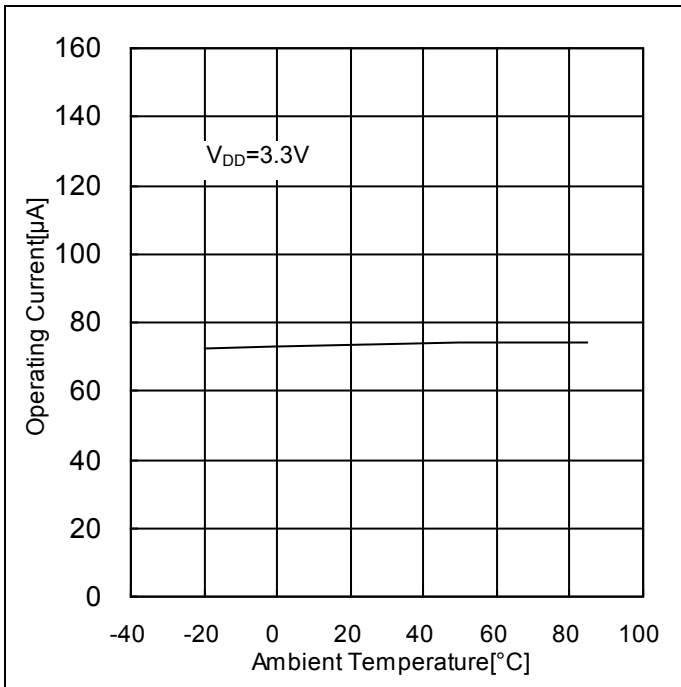

Figure 1. Operating Current vs Ambient Temperature

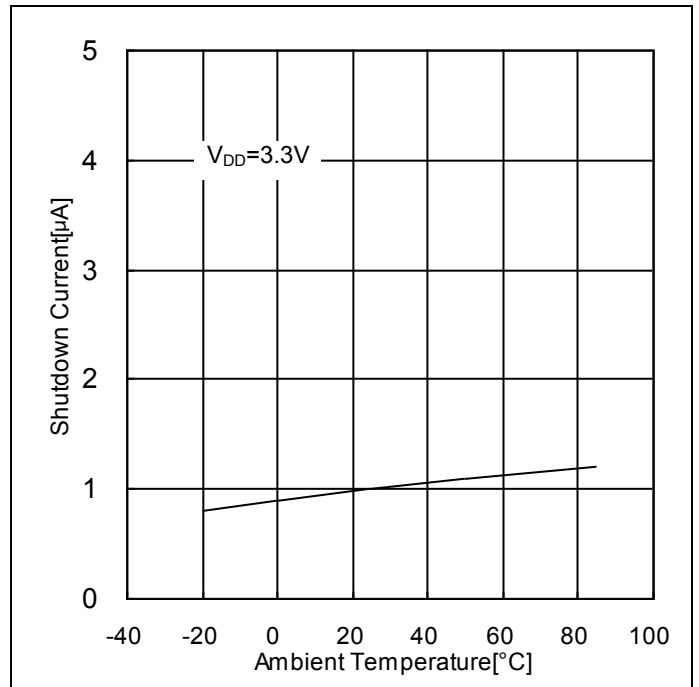

Figure 2. Shutdown Current vs Ambient Temperature

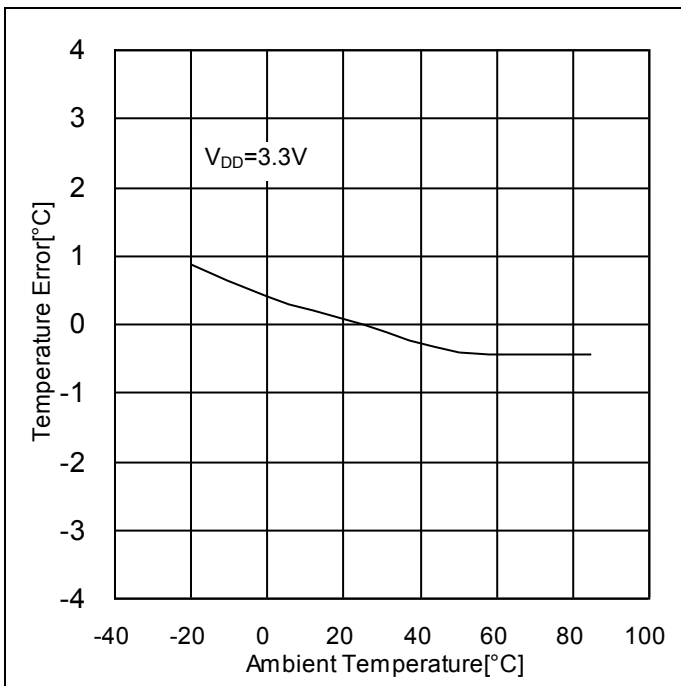
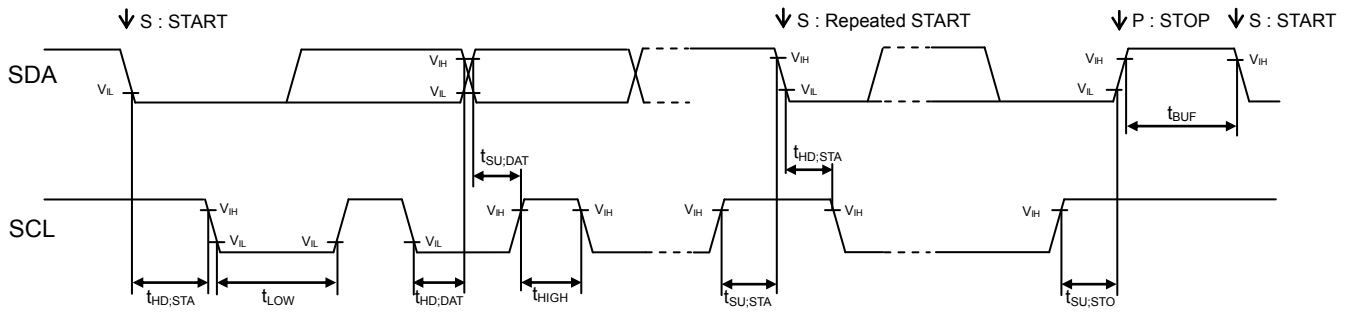

Figure 3. Temperature Error vs Ambient Temperature

Two-wire Serial Interface Timing Characteristics (Unless otherwise specified $V_{DD}=3.3V$, $T_a=25^\circ C$)

Parameter	Symbol	Min	Typ	Max	Unit	Conditions
SCL Clock frequency	f_{SCL}	0	-	400	kHz	
'L' Period of the SCL Clock	t_{LOW}	1.3	-	-	μs	
'H' Period of the SCL Clock	t_{HIGH}	0.6	-	-	μs	
Setup Time for Repeated START	$t_{SU,STA}$	0.6	-	-	μs	
Hold Time for START	$t_{HD,STA}$	0.6	-	-	μs	
Data Setup Time	$t_{SU,DAT}$	100	-	-	ns	
Data Hold Time	$t_{HD,DAT}$	0	-	-	μs	
Setup Time for STOP	$t_{SU,STO}$	0.6	-	-	μs	
Bus Free Time between STOP and START	t_{BUF}	1.3	-	-	μs	

Two-wire Serial Communication

1. Write format

(1) Writing 1Byte data

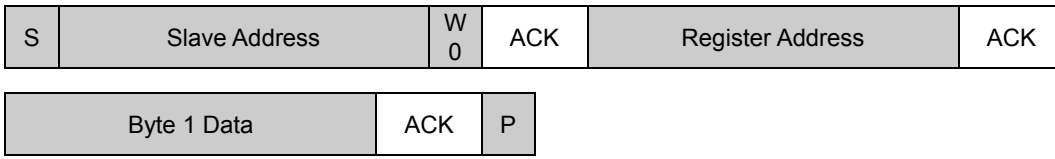

(2) Writing 2Byte data

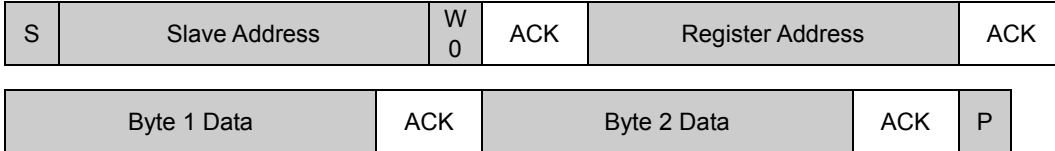

2. Read format

(1) Reading 2Byte data after setting register address

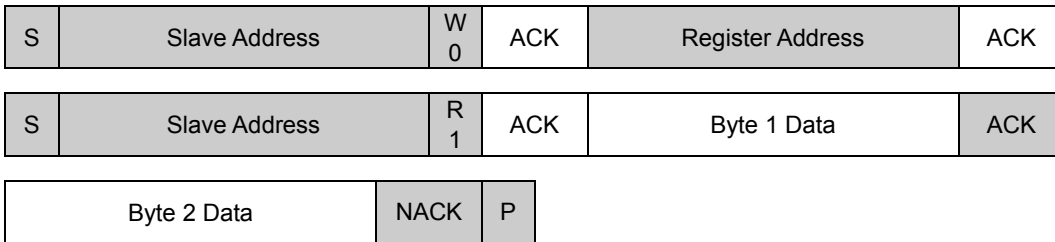

(2) Reading data of the addressed register

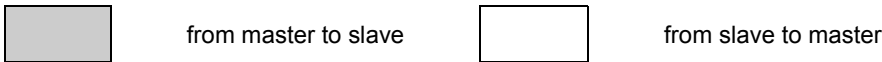
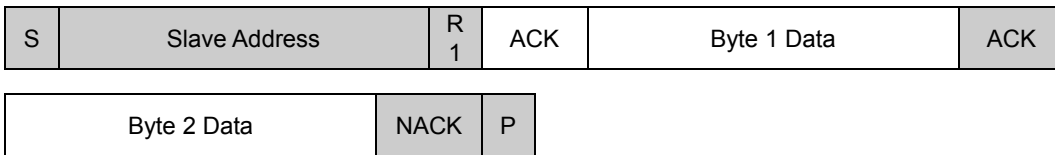

4. Slave Address

The slave address is selectable from 8 addresses by A0, A1, A2 pins.

A2	A1	A0	Slave Address
L	L	L	1001000
L	L	H	1001001
L	H	L	1001010
L	H	H	1001011
H	L	L	1001100
H	L	H	1001101
H	H	L	1001110
H	H	H	1001111

Register Map (Note 1)

Register Address	Register Name	R/W	Byte	D7	D6	D5	D4	D3	D2	D1	D0
0x00	Temperature Register	R	1	Temperature Data[11:4]							
			2	Temperature Data[3:0]				0	0	0	0
0x01	Configuration Register	RW	1	OS	ALERT	0	FAULT QUEUE[1:0]		POL	0	SD
			2	0	0	0	0	0	0	WT[1:0]	
0x02	T _{LOW} Register	RW	1	T _{LOW} Limit[11:4]							
			2	T _{LOW} Limit[3:0]				0	0	0	0
0x03	T _{HIGH} Register	RW	1	T _{HIGH} Limit[11:4]							
			2	T _{HIGH} Limit[3:0]				0	0	0	0
0x04	Software Reset	RW	1	0	0	0	0	0	0	0	SW RST

(Note 1) Do not write any commands to other addresses except above. Do not write '1' to the fields in which value is '0' in above table.

(0x00) Temperature Register

Fields	Function
Temperature Data[11:0]	<p>Measurement Temperature Data Output Register. Negative numbers are represented in binary two's complement format. The Temperature Register is 0x0000 until the first conversion complete after a software reset or power-on. Conversion to temperature value is like below.</p> <p>Measurement Temperature Value [°C] = Temperature Data [11:0] x 0.0625</p>

default value 0x0000

(0x01) Configuration Register

Fields	Function
OS	<p>When the device is in shutdown mode, writing '1' to the OS bit starts a single temperature measurement. The device returns to the shutdown state at the completion of the single measurement. 0 : Continuous Measurement 1 : Single Measurement When reading '0' is read.</p>
ALERT	<p>The ALERT bit is a read-only register, it provides information of interrupt state. The ALERT bit becomes '0', when Temperature Data or ALERT is read. 0 : Interrupt is not active 1 : Interrupt is active</p>
FAULT QUEUE[1:0]	<p>The FAULT QUEUE is number of consecutive times. When consecutive measurement values are out of range, the ALERT pin state changes. 00 : Single 01 : 2times 10 : 4times 11 : 6times</p>
POL	<p>The POL bit selects the polarity of the ALERT pin output. 0 : Active Low 1 : Active High</p>
SD	<p>When '1' is written in SD field, it becomes shut down mode after the measurement temperature. 0 : Active 1 : Shut Down</p>

(0x01) Configuration Register - continued

Fields	Function
WT[1:0]	<p>This device operating intermittently, wait time can be selected.</p> <p>00 : (186240 x 16) / F_{OSC} [sec] 01 : (186240 x 4) / F_{OSC} [sec] 10 : (186240 x 1) / F_{OSC} [sec] 11 : (186240 x 0.5) / F_{OSC} [sec]</p>

default value 0x0002

(0x02) T_{LOW} Register

Fields	Function
T _{LOW} Limit [11:0]	<p>Lower Temperature Limit Setting Register. Negative numbers are represented in binary twos complement format. It has to be set as T_{LOW} Limit < T_{HIGH} Limit. Conversion to T_{LOW} temperature value is like below.</p> <p>Lower Temperature Limit [°C] = T_{LOW} Limit [11:0] x 0.0625</p>

default value 0x4B00

(0x03) T_{HIGH} Register

Fields	Function
T _{HIGH} Limit [11:0]	<p>Upper Temperature Limit Setting Register. Negative numbers are represented in binary twos complement format. It has to be set as T_{HIGH} Limit > T_{LOW} Limit. Conversion to T_{HIGH} temperature value is like below.</p> <p>Upper Temperature Limit [°C] = T_{HIGH} Limit [11:0] x 0.0625</p>

default value 0x5000

(0x04) Software Reset

Fields	Function
SW_RST	<p>Reset process is performed when writing SW_RST='1'. '1' is not written in register SW_RST.</p>

default value 0xFF

Caution: Read value of Software Reset Register is always 0xFF.

Thermostat mode

When the consecutive measurement temperature value exceeds the value in T_{HIGH} Limit, the device becomes interrupt and the ALERT pin becomes active. The number of consecutive times is set in FAULT QUEUE.

Interrupt is released when any of below action is taken.

- The device becomes shut down mode.
- Temperature Data or ALERT is read.
- Measurement temperature value falls below the value in T_{LOW} Limit consecutively over same times as FAULT QUEUE.

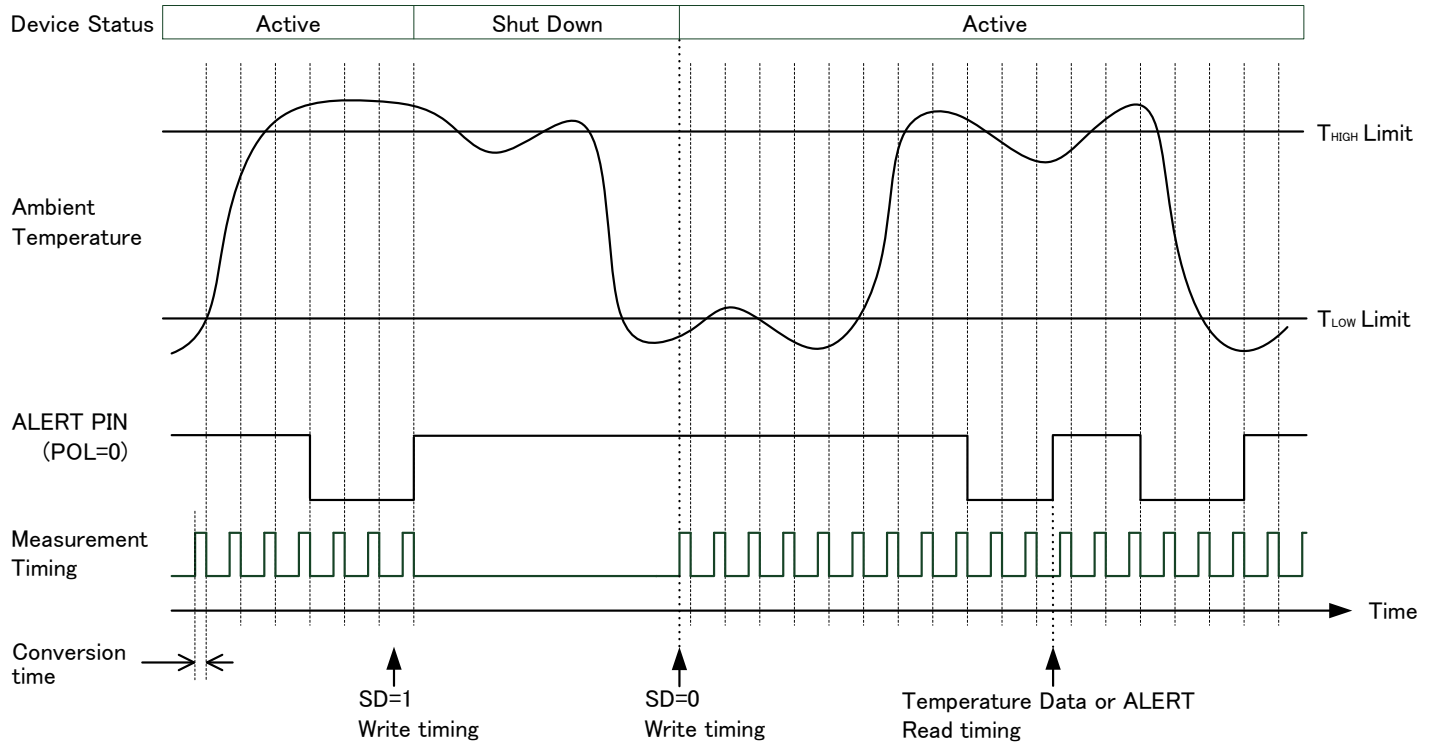
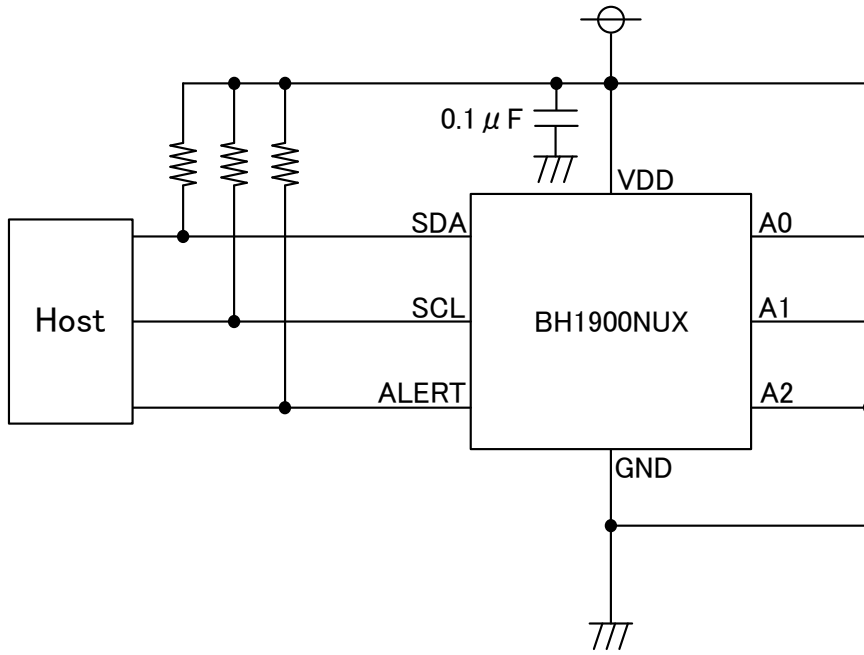

Figure 4. Comparator Mode Action Sequence
(Consecutive times = 2times)

Application Example



When address pins are A2=L, A1=L, A0=H.

Caution: Adjust the bypass capacitor value as necessary, according to voltage noise conditions, etc. It is recommended to place bypass capacitance as near the IC as possible.

I/O equivalence circuit

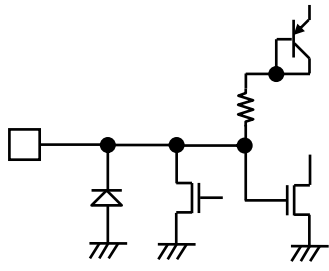
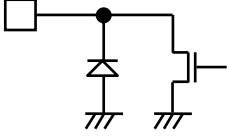
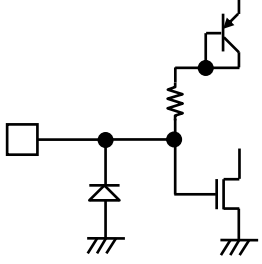
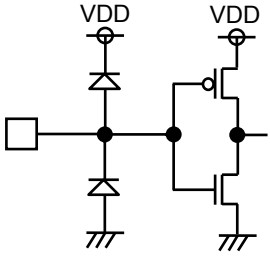
Pin Name	Equivalent Circuit	Pin Name	Equivalent Circuit
SDA		ALERT	
SCL		A0 A1 A2	

Operational Notes

1. Reverse Connection of Power Supply

Connecting the power supply in reverse polarity can damage the IC. Take precautions against reverse polarity when connecting the power supply, such as mounting an external diode between the power supply and the IC's power supply pins.

2. Power Supply Lines

Design the PCB layout pattern to provide low impedance supply lines. Furthermore, connect a capacitor to ground at all power supply pins. Consider the effect of temperature and aging on the capacitance value when using electrolytic capacitors.

3. Ground Voltage

Ensure that no pins are at a voltage below that of the ground pin at any time, even during transient condition.

4. Ground Wiring Pattern

When using both small-signal and large-current ground traces, the two ground traces should be routed separately but connected to a single ground at the reference point of the application board to avoid fluctuations in the small-signal ground caused by large currents. Also ensure that the ground traces of external components do not cause variations on the ground voltage. The ground lines must be as short and thick as possible to reduce line impedance.

5. Thermal Consideration

Should by any chance the maximum junction temperature rating be exceeded the rise in temperature of the chip may result in deterioration of the properties of the chip. In case of exceeding this absolute maximum rating, increase the board size and copper area to prevent exceeding the maximum junction temperature rating.

6. Recommended Operating Conditions

These conditions represent a range within which the expected characteristics of the IC can be approximately obtained. The electrical characteristics are guaranteed under the conditions of each parameter.

7. Inrush Current

When power is first supplied to the IC, it is possible that the internal logic may be unstable and inrush current may flow instantaneously due to the internal powering sequence and delays, especially if the IC has more than one power supply. Therefore, give special consideration to power coupling capacitance, power wiring, width of ground wiring, and routing of connections.

8. Operation Under Strong Electromagnetic Field

Operating the IC in the presence of a strong electromagnetic field may cause the IC to malfunction.

9. Testing on Application Boards

When testing the IC on an application board, connecting a capacitor directly to a low-impedance output pin may subject the IC to stress. Always discharge capacitors completely after each process or step. The IC's power supply should always be turned off completely before connecting or removing it from the test setup during the inspection process. To prevent damage from static discharge, ground the IC during assembly and use similar precautions during transport and storage.

10. Inter-pin Short and Mounting Errors

Ensure that the direction and position are correct when mounting the IC on the PCB. Incorrect mounting may result in damaging the IC. Avoid nearby pins being shorted to each other especially to ground, power supply and output pin. Inter-pin shorts could be due to many reasons such as metal particles, water droplets (in very humid environment) and unintentional solder bridge deposited in between pins during assembly to name a few.

11. Unused Input Pins

Input pins of an IC are often connected to the gate of a MOS transistor. The gate has extremely high impedance and extremely low capacitance. If left unconnected, the electric field from the outside can easily charge it. The small charge acquired in this way is enough to produce a significant effect on the conduction through the transistor and cause unexpected operation of the IC. So unless otherwise specified, unused input pins should be connected to the power supply or ground line.

Operational Notes – continued

12. Regarding the Input Pin of the IC

This monolithic IC contains P+ isolation and P substrate layers between adjacent elements in order to keep them isolated. P-N junctions are formed at the intersection of the P layers with the N layers of other elements, creating a parasitic diode or transistor. For example (refer to figure below):

When $GND > Pin A$ and $GND > Pin B$, the P-N junction operates as a parasitic diode.

When $GND > Pin B$, the P-N junction operates as a parasitic transistor.

Parasitic diodes inevitably occur in the structure of the IC. The operation of parasitic diodes can result in mutual interference among circuits, operational faults, or physical damage. Therefore, conditions that cause these diodes to operate, such as applying a voltage lower than the GND voltage to an input pin (and thus to the P substrate) should be avoided.

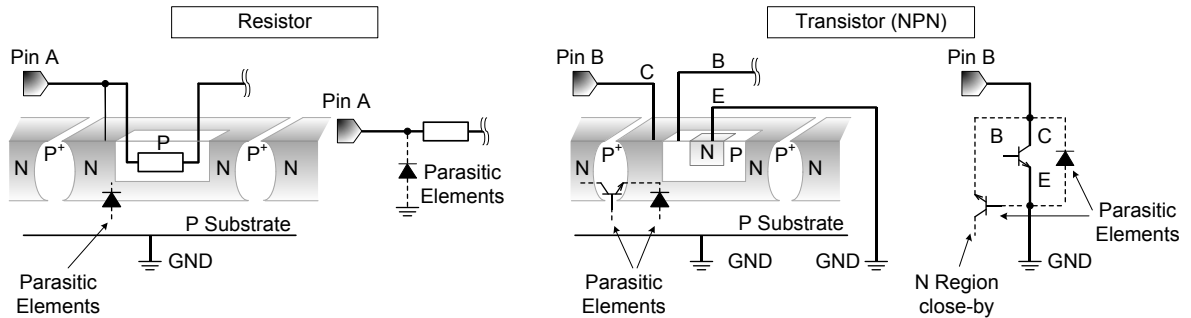

Figure 5. Example of monolithic IC structure

13. Ceramic Capacitor

When using a ceramic capacitor, determine the dielectric constant considering the change of capacitance with temperature and the decrease in nominal capacitance due to DC bias and others.

14. Area of Safe Operation (ASO)

Operate the IC such that the output voltage, output current, and the maximum junction temperature rating are all within the Area of Safe Operation (ASO).

Ordering Information

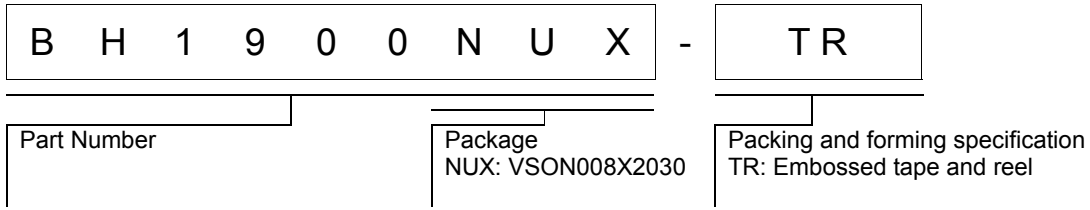

Marking Diagrams

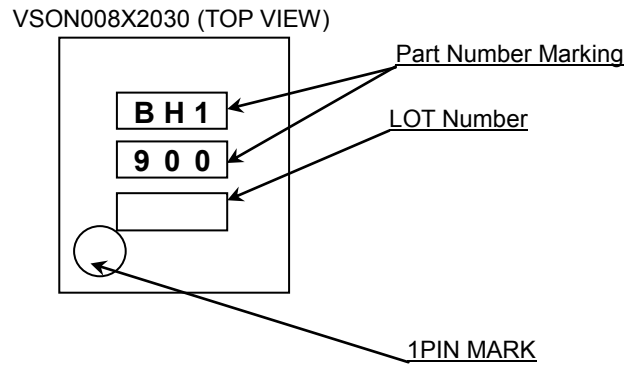

Physical Dimension, Tape and Reel Information

Package Name	VSON008X2030
--------------	--------------

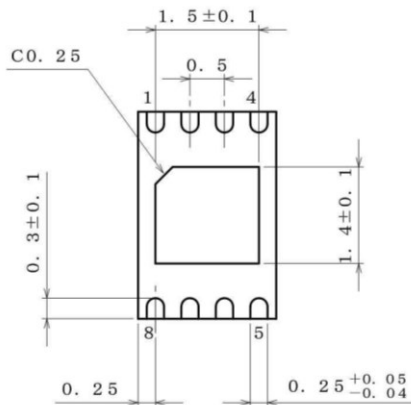
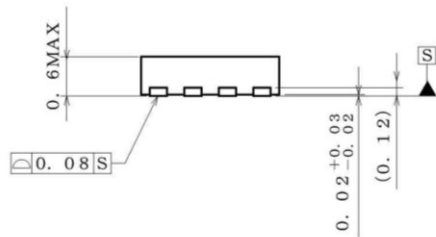
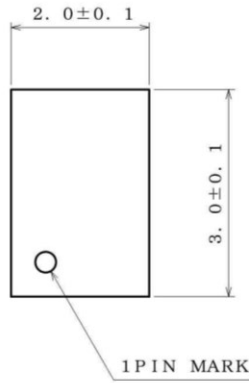

(UNIT : mm)
 PKG : VSON008X2030
 Drawing No. EX187-5001

<Tape and Reel information>

Tape	Embossed carrier tape
Quantity	4000pcs
Direction of feed	TR (The direction is the 1pin of product is at the upper right when you hold reel on the left hand and you pull out the tape on the right hand)

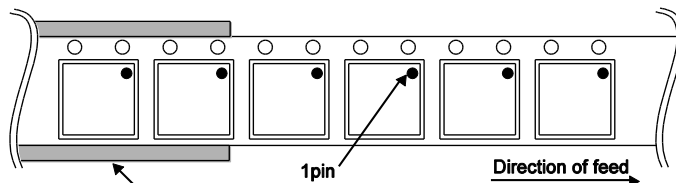

*Order quantity needs to be multiple of the minimum quantity.

Revision History

Date	Revision	Changes
26.Apr.2016	001	New Release

Notice

Precaution on using ROHM Products

- Our Products are designed and manufactured for application in ordinary electronic equipments (such as AV equipment, OA equipment, telecommunication equipment, home electronic appliances, amusement equipment, etc.). If you intend to use our Products in devices requiring extremely high reliability (such as medical equipment ^(Note 1), transport equipment, traffic equipment, aircraft/spacecraft, nuclear power controllers, fuel controllers, car equipment including car accessories, safety devices, etc.) and whose malfunction or failure may cause loss of human life, bodily injury or serious damage to property ("Specific Applications"), please consult with the ROHM sales representative in advance. Unless otherwise agreed in writing by ROHM in advance, ROHM shall not be in any way responsible or liable for any damages, expenses or losses incurred by you or third parties arising from the use of any ROHM's Products for Specific Applications.

(Note1) Medical Equipment Classification of the Specific Applications

JAPAN	USA	EU	CHINA
CLASS III	CLASS III	CLASS II b	CLASS III
CLASS IV		CLASS III	

- ROHM designs and manufactures its Products subject to strict quality control system. However, semiconductor products can fail or malfunction at a certain rate. Please be sure to implement, at your own responsibilities, adequate safety measures including but not limited to fail-safe design against the physical injury, damage to any property, which a failure or malfunction of our Products may cause. The following are examples of safety measures:
 - Installation of protection circuits or other protective devices to improve system safety
 - Installation of redundant circuits to reduce the impact of single or multiple circuit failure
- Our Products are designed and manufactured for use under standard conditions and not under any special or extraordinary environments or conditions, as exemplified below. Accordingly, ROHM shall not be in any way responsible or liable for any damages, expenses or losses arising from the use of any ROHM's Products under any special or extraordinary environments or conditions. If you intend to use our Products under any special or extraordinary environments or conditions (as exemplified below), your independent verification and confirmation of product performance, reliability, etc. prior to use, must be necessary:
 - Use of our Products in any types of liquid, including water, oils, chemicals, and organic solvents
 - Use of our Products outdoors or in places where the Products are exposed to direct sunlight or dust
 - Use of our Products in places where the Products are exposed to sea wind or corrosive gases, including Cl₂, H₂S, NH₃, SO₂, and NO₂
 - Use of our Products in places where the Products are exposed to static electricity or electromagnetic waves
 - Use of our Products in proximity to heat-producing components, plastic cords, or other flammable items
 - Sealing or coating our Products with resin or other coating materials
 - Use of our Products without cleaning residue of flux (even if you use no-clean type fluxes, cleaning residue of flux is recommended); or Washing our Products by using water or water-soluble cleaning agents for cleaning residue after soldering
 - Use of the Products in places subject to dew condensation
- The Products are not subject to radiation-proof design.
- Please verify and confirm characteristics of the final or mounted products in using the Products.
- In particular, if a transient load (a large amount of load applied in a short period of time, such as pulse. is applied, confirmation of performance characteristics after on-board mounting is strongly recommended. Avoid applying power exceeding normal rated power; exceeding the power rating under steady-state loading condition may negatively affect product performance and reliability.
- De-rate Power Dissipation depending on ambient temperature. When used in sealed area, confirm that it is the use in the range that does not exceed the maximum junction temperature.
- Confirm that operation temperature is within the specified range described in the product specification.
- ROHM shall not be in any way responsible or liable for failure induced under deviant condition from what is defined in this document.

Precaution for Mounting / Circuit board design

- When a highly active halogenous (chlorine, bromine, etc.) flux is used, the residue of flux may negatively affect product performance and reliability.
- In principle, the reflow soldering method must be used on a surface-mount products, the flow soldering method must be used on a through hole mount products. If the flow soldering method is preferred on a surface-mount products, please consult with the ROHM representative in advance.

For details, please refer to ROHM Mounting specification

Precautions Regarding Application Examples and External Circuits

1. If change is made to the constant of an external circuit, please allow a sufficient margin considering variations of the characteristics of the Products and external components, including transient characteristics, as well as static characteristics.
2. You agree that application notes, reference designs, and associated data and information contained in this document are presented only as guidance for Products use. Therefore, in case you use such information, you are solely responsible for it and you must exercise your own independent verification and judgment in the use of such information contained in this document. ROHM shall not be in any way responsible or liable for any damages, expenses or losses incurred by you or third parties arising from the use of such information.

Precaution for Electrostatic

This Product is electrostatic sensitive product, which may be damaged due to electrostatic discharge. Please take proper caution in your manufacturing process and storage so that voltage exceeding the Products maximum rating will not be applied to Products. Please take special care under dry condition (e.g. Grounding of human body / equipment / solder iron, isolation from charged objects, setting of Ionizer, friction prevention and temperature / humidity control).

Precaution for Storage / Transportation

1. Product performance and soldered connections may deteriorate if the Products are stored in the places where:
 - [a] the Products are exposed to sea winds or corrosive gases, including Cl₂, H₂S, NH₃, SO₂, and NO₂
 - [b] the temperature or humidity exceeds those recommended by ROHM
 - [c] the Products are exposed to direct sunshine or condensation
 - [d] the Products are exposed to high Electrostatic
2. Even under ROHM recommended storage condition, solderability of products out of recommended storage time period may be degraded. It is strongly recommended to confirm solderability before using Products of which storage time is exceeding the recommended storage time period.
3. Store / transport cartons in the correct direction, which is indicated on a carton with a symbol. Otherwise bent leads may occur due to excessive stress applied when dropping of a carton.
4. Use Products within the specified time after opening a humidity barrier bag. Baking is required before using Products of which storage time is exceeding the recommended storage time period.

Precaution for Product Label

A two-dimensional barcode printed on ROHM Products label is for ROHM's internal use only.

Precaution for Disposition

When disposing Products please dispose them properly using an authorized industry waste company.

Precaution for Foreign Exchange and Foreign Trade act

Since concerned goods might be fallen under listed items of export control prescribed by Foreign exchange and Foreign trade act, please consult with ROHM in case of export.

Precaution Regarding Intellectual Property Rights

1. All information and data including but not limited to application example contained in this document is for reference only. ROHM does not warrant that foregoing information or data will not infringe any intellectual property rights or any other rights of any third party regarding such information or data.
2. ROHM shall not have any obligations where the claims, actions or demands arising from the combination of the Products with other articles such as components, circuits, systems or external equipment (including software).
3. No license, expressly or implied, is granted hereby under any intellectual property rights or other rights of ROHM or any third parties with respect to the Products or the information contained in this document. Provided, however, that ROHM will not assert its intellectual property rights or other rights against you or your customers to the extent necessary to manufacture or sell products containing the Products, subject to the terms and conditions herein.

Other Precaution

1. This document may not be reprinted or reproduced, in whole or in part, without prior written consent of ROHM.
2. The Products may not be disassembled, converted, modified, reproduced or otherwise changed without prior written consent of ROHM.
3. In no event shall you use in any way whatsoever the Products and the related technical information contained in the Products or this document for any military purposes, including but not limited to, the development of mass-destruction weapons.
4. The proper names of companies or products described in this document are trademarks or registered trademarks of ROHM, its affiliated companies or third parties.

General Precaution

1. Before you use our Products, you are requested to carefully read this document and fully understand its contents. ROHM shall not be in any way responsible or liable for failure, malfunction or accident arising from the use of any ROHM's Products against warning, caution or note contained in this document.
2. All information contained in this document is current as of the issuing date and subject to change without any prior notice. Before purchasing or using ROHM's Products, please confirm the latest information with a ROHM sales representative.
3. The information contained in this document is provided on an "as is" basis and ROHM does not warrant that all information contained in this document is accurate and/or error-free. ROHM shall not be in any way responsible or liable for any damages, expenses or losses incurred by you or third parties resulting from inaccuracy or errors of or concerning such information.

Mouser Electronics

Authorized Distributor

Click to View Pricing, Inventory, Delivery & Lifecycle Information:

[ROHM Semiconductor:](#)

[BH1900NUX-TR](#)

Компания «Океан Электроники» предлагает заключение долгосрочных отношений при поставках импортных электронных компонентов на взаимовыгодных условиях!

Наши преимущества:

- Поставка оригинальных импортных электронных компонентов напрямую с производств Америки, Европы и Азии, а так же с крупнейших складов мира;
- Широкая линейка поставок активных и пассивных импортных электронных компонентов (более 30 млн. наименований);
- Поставка сложных, дефицитных, либо снятых с производства позиций;
- Оперативные сроки поставки под заказ (от 5 рабочих дней);
- Экспресс доставка в любую точку России;
- Помощь Конструкторского Отдела и консультации квалифицированных инженеров;
- Техническая поддержка проекта, помощь в подборе аналогов, поставка прототипов;
- Поставка электронных компонентов под контролем ВП;
- Система менеджмента качества сертифицирована по Международному стандарту ISO 9001;
- При необходимости вся продукция военного и аэрокосмического назначения проходит испытания и сертификацию в лаборатории (по согласованию с заказчиком);
- Поставка специализированных компонентов военного и аэрокосмического уровня качества (Xilinx, Altera, Analog Devices, Intersil, Interpoint, Microsemi, Actel, Aeroflex, Peregrine, VPT, Syfer, Eurofarad, Texas Instruments, MS Kennedy, Miteq, Cobham, E2V, MA-COM, Hittite, Mini-Circuits, General Dynamics и др.);

Компания «Океан Электроники» является официальным дистрибьютором и эксклюзивным представителем в России одного из крупнейших производителей разъемов военного и аэрокосмического назначения «**JONHON**», а так же официальным дистрибьютором и эксклюзивным представителем в России производителя высокотехнологичных и надежных решений для передачи СВЧ сигналов «**FORSTAR**».



JONHON

«**JONHON**» (основан в 1970 г.)

Разъемы специального, военного и аэрокосмического назначения:

(Применяются в военной, авиационной, аэрокосмической, морской, железнодорожной, горно- и нефтедобывающей отраслях промышленности)

«**FORSTAR**» (основан в 1998 г.)

ВЧ соединители, коаксиальные кабели, кабельные сборки и микроволновые компоненты:

(Применяются в телекоммуникациях гражданского и специального назначения, в средствах связи, РЛС, а так же военной, авиационной и аэрокосмической отраслях промышленности).



Телефон: 8 (812) 309-75-97 (многоканальный)

Факс: 8 (812) 320-03-32

Электронная почта: ocean@oceanchips.ru

Web: <http://oceanchips.ru/>

Адрес: 198099, г. Санкт-Петербург, ул. Калинина, д. 2, корп. 4, лит. А