



# Low-Power Digital Potentiometers

MAX5160/MAX5161

## General Description

The MAX5160/MAX5161 linear-taper digital potentiometers perform the same function as a mechanical potentiometer or a variable resistor. They consist of a fixed resistor and a wiper contact with 32 tap points that are digitally controlled by three lines for the 8-pin MAX5160 or by two lines for the 6-pin MAX5161.

These parts are ideal for applications requiring digitally controlled resistors. Three resistance values are available for each part type: 50kΩ, 100kΩ, and 200kΩ. A nominal resistor temperature coefficient of 50ppm/°C end-to-end and only 5ppm/°C ratiometric makes the MAX5160 ideal for applications requiring a low-temperature-coefficient variable resistor, such as low-tempco, adjustable-gain circuit configurations.

The MAX5160 is available in an 8-pin μMAX package, and the MAX5161 is available in a 6-pin SOT23 package. Both devices are guaranteed over the extended-industrial temperature range (-40°C to +85°C).

## Applications

- LCD Screen Adjustment
- Volume Control
- Mechanical Potentiometer Replacement

## Selector Guide

PART	TOP MARK	R (kΩ)
MAX5160NEUA	—	200
MAX5160MEUA	—	100
MAX5160LEUA	—	50
MAX5161NEZT	AAAC	200
MAX5161MEZT	AAAB	100
MAX5161LEZT	AAAA	50

## Pin Configurations

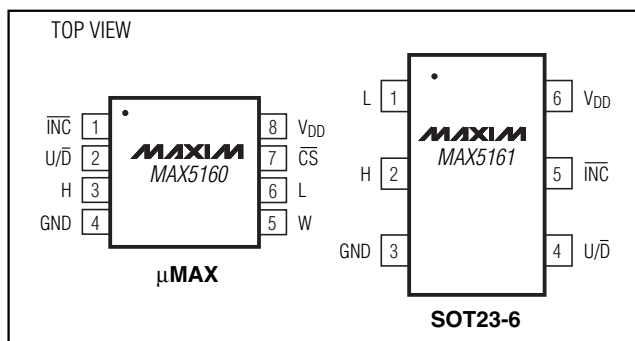

## Features

- ◆ 32 Tap Positions
- ◆ 50kΩ, 100kΩ, and 200kΩ Resistance Values
- ◆ 400Ω Wiper Resistance
- ◆ ±25% Resistance Tolerance
- ◆ 3-Wire Serial Data Input
- ◆ ±1LSB DNL
- ◆ ±0.5LSB INL
- ◆ 100nA Supply Current
- ◆ +2.7V to +5.5V Single-Supply Operation
- ◆ Power-On Reset: Wiper Goes to Midscale (position 16)
- ◆ ±2kV ESD Protection
- ◆ Small-Footprint Packages
  - 6-Pin SOT23 (MAX5161)
  - 8-Pin μMAX (MAX5160)
- ◆ Glitchless Switching Between the Resistor Taps

## Ordering Information

PART	TEMP. RANGE	PIN-PACKAGE	R (kΩ)
MAX5160NEUA	-40°C to +85°C	8 μMAX	200
MAX5160MEUA	-40°C to +85°C	8 μMAX	100
MAX5160LEUA	-40°C to +85°C	8 μMAX	50
MAX5161NEZT	-40°C to +85°C	6 SOT23	200
MAX5161MEZT	-40°C to +85°C	6 SOT23	100
MAX5161LEZT	-40°C to +85°C	6 SOT23	50

## Functional Diagram

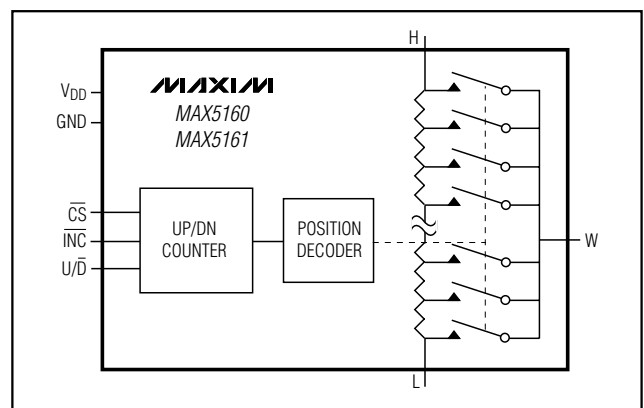

# Low-Power Digital Potentiometers

## ABSOLUTE MAXIMUM RATINGS

V <sub>DD</sub> to GND .....	-0.3V to +6V	Continuous Power Dissipation (T <sub>A</sub> = +70°C)	
CS, INC, U/D to GND .....	-0.3V to +6V	6-Pin SOT23 (derate 6.25mW/°C above +70°C).....	500mW
H, L, W to GND .....	-0.3V to (V <sub>DD</sub> + 0.3V)	8-Pin μMAX (derate 4.1mW/°C above +70°C).....	330mW
Input and Output Latchup Immunity .....	±200mA	Operating Temperature Range .....	-40°C to +85°C
Maximum Continuous Current into H, L, and W		Storage Temperature Range .....	-65°C to +150°C
MAX516__E__ .....	±1mA	Lead Temperature (soldering, 10s) .....	+300°C

Stresses beyond those listed under "Absolute Maximum Ratings" may cause permanent damage to the device. These are stress ratings only, and functional operation of the device at these or any other conditions beyond those indicated in the operational sections of the specifications is not implied. Exposure to absolute maximum rating conditions for extended periods may affect device reliability.

## ELECTRICAL CHARACTERISTICS

(V<sub>DD</sub> = +2.7V to +5.5V, V<sub>H</sub> = V<sub>DD</sub>, V<sub>L</sub> = 0, T<sub>A</sub> = T<sub>MIN</sub> to T<sub>MAX</sub>. Typical values are at V<sub>DD</sub> = +5V, T<sub>A</sub> = +25°C, unless otherwise noted.)

PARAMETER	SYMBOL	CONDITIONS	MIN	TYP	MAX	UNITS
<b>DC PERFORMANCE</b>						
Resolution				3		%
Integral Nonlinearity (Note 1)	INL				±1/2	LSB
Differential Nonlinearity (Note 1)	DNL				±1	LSB
End-to-End Resistor Tempco	TC <sub>R</sub>			50		ppm/°C
Ratiometric Resistor Tempco				5		ppm/°C
Full-Scale Error					-0.1	LSB
Zero-Scale Error					+0.1	LSB
Wiper Resistance	R <sub>W</sub>			400	1700	Ω
Wiper Capacitance	C <sub>W</sub>			10		pF
End-to-End Resistance	HL	MAX516_NE__	150	200	250	kΩ
		MAX516_ME__	75	100	125	
		MAX516_LE__	37.5	50	62.5	
<b>DIGITAL INPUTS</b>						
Input High Voltage	V <sub>IH</sub>		0.7 × V <sub>DD</sub>			V
Input Low Voltage	V <sub>IL</sub>			0.3 × V <sub>DD</sub>		V
Input Leakage Current					±1	μA
Input Capacitance				5		pF
<b>TIMING CHARACTERISTICS</b> (Figure 6)						
CS to INC Setup Time	t <sub>CI</sub>		25			ns
CS to INC Hold Time	t <sub>IC</sub>		0			ns
INC Low Period	t <sub>IL</sub>		25			ns
INC High Period	t <sub>IH</sub>		25			ns
U/D to INC Hold	t <sub>ID</sub>		0			ns
U/D to INC Setup	t <sub>DI</sub>		50			ns
Wiper-Settling Time	t <sub>IW</sub>			1		μs
INC Frequency	f <sub>IMAX</sub>				7	MHz
<b>POWER SUPPLIES</b>						
Supply Voltage	V <sub>DD</sub>		2.7		5.5	V
Supply Current	I <sub>DD</sub>	CS = INC = U/D = V <sub>DD</sub> or GND	V <sub>DD</sub> = +5V	0.6	10	μA
			V <sub>DD</sub> = +2.7V	135		nA

**Note 1:** For the MAX5160, linearity is defined in terms of H to L code-dependent resistance.

# Low-Power Digital Potentiometers

## Typical Operating Characteristics

( $V_{DD} = +5V$ ,  $T_A = +25^\circ C$ , unless otherwise noted.)

MAX5160/MAX5161

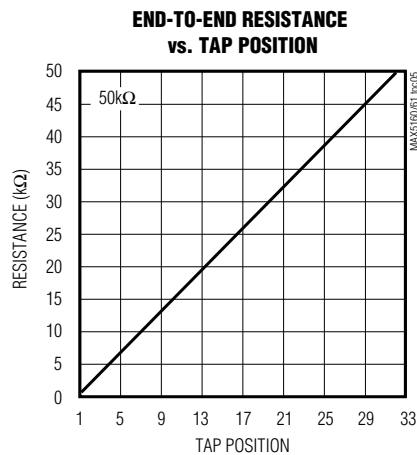
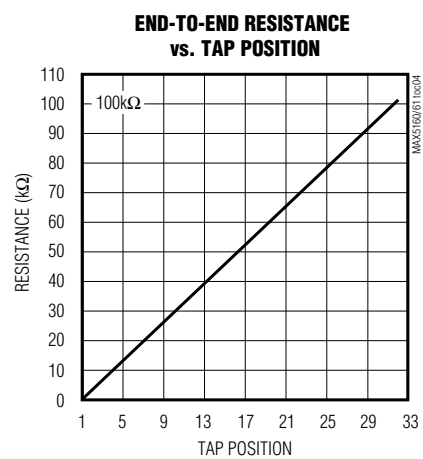
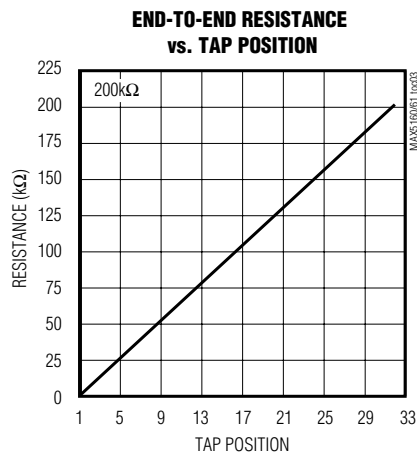
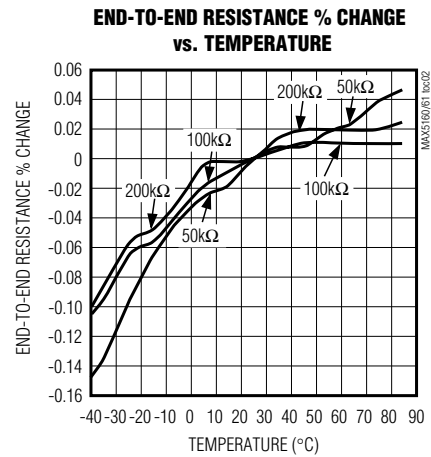
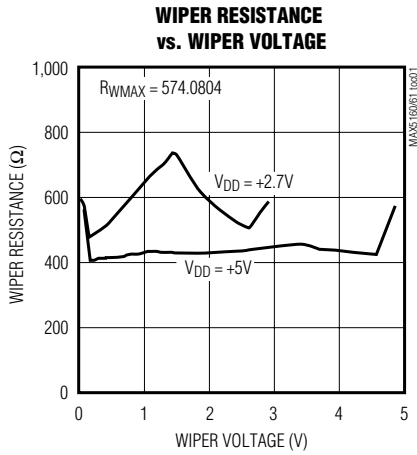

# Low-Power Digital Potentiometers

## Typical Operating Characteristics (continued)

( $V_{DD} = +5V$ ,  $T_A = +25^\circ C$ , unless otherwise noted.)

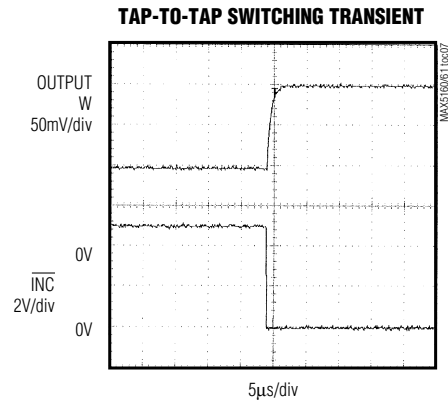
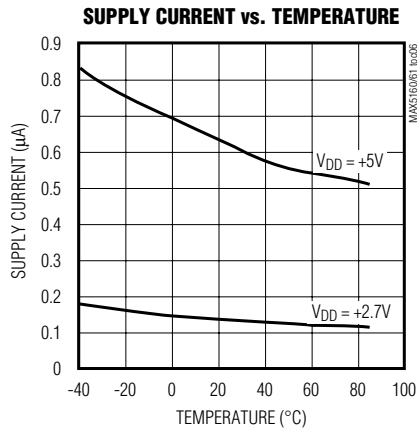

## Pin Description

PIN		NAME	FUNCTION
MAX5160	MAX5161		
1	5	$\overline{INC}$	Wiper Increment Control Input. With $\overline{CS}$ low, a high-to-low transition increments ( $U/\overline{D}$ high) or decrements ( $U/\overline{D}$ low) the wiper position.
2	4	$U/\overline{D}$	Up/Down Control Input. With $\overline{CS}$ low, a high-to-low $\overline{INC}$ transition increments ( $U/\overline{D}$ high) or decrements ( $U/\overline{D}$ low) the wiper position.
3	2	H	High Terminal of Resistor
4	3	GND	Ground
5	—	W	Wiper Terminal of Resistor
6	1	L	Low Terminal of Resistor
7	—	$\overline{CS}$	Chip-Select Input. Drive low to change the wiper position through $\overline{INC}$ and $U/\overline{D}$ .
8	6	$V_{DD}$	Power Supply

# Low-Power Digital Potentiometers

## Detailed Description

The MAX5160/MAX5161 consist of resistor arrays with thirty-one resistive elements. Thirty-two tap points are accessible to the wiper along the resistor string between H and L. Logic inputs  $\overline{CS}$ ,  $U/\overline{D}$ , and  $\overline{INC}$  determine the position of the wiper. With  $\overline{CS}$  low and  $U/\overline{D}$  high, a high-to-low transition on  $\overline{INC}$  increments the internal counter, increasing the resistance between W and L. When both  $\overline{CS}$  and  $U/\overline{D}$  are low, a high-to-low  $\overline{INC}$  transition decrements the internal counter, decreasing the resistance between W and L. At either end (maximum or minimum positions), additional transitions in the direction of the end points will not change the counter value (the counter will not wrap around).

The H and L terminals of the MAX5160 are similar to the two end terminals of a mechanical potentiometer. The tap W is equivalent to the variable tap (wiper) of the potentiometer.

The MAX5161 is similar to the MAX5160 except that  $\overline{CS}$  internally connects to ground and the wiper terminal (W) is shorted to the high terminal (H). The MAX5161 acts as

a variable resistor (a potentiometer with the wiper and one end terminal shorted together).

The MAX5160/MAX5161 feature power-on reset circuitry that sets the wiper position to midscale at power-up.

## Applications Information

The MAX5160/MAX5161 are intended for circuits requiring digitally controlled adjustable voltage or adjustable gain, such as LCD contrast control, where voltage biasing adjusts the display contrast.

### Controlling a Switch-Mode LCD Bias Generator

Figure 1 shows an application where the MAX5161 is used with a MAX1771 to make an adjustable positive LCD-bias circuit. The output of the MAX1771 is a positive voltage that is digitally controlled through the MAX5160/MAX5161. Similarly, Figure 2 shows the application of the MAX5161 in a digitally controlled negative LCD-bias circuit along with the MAX774/MAX775/MAX776.

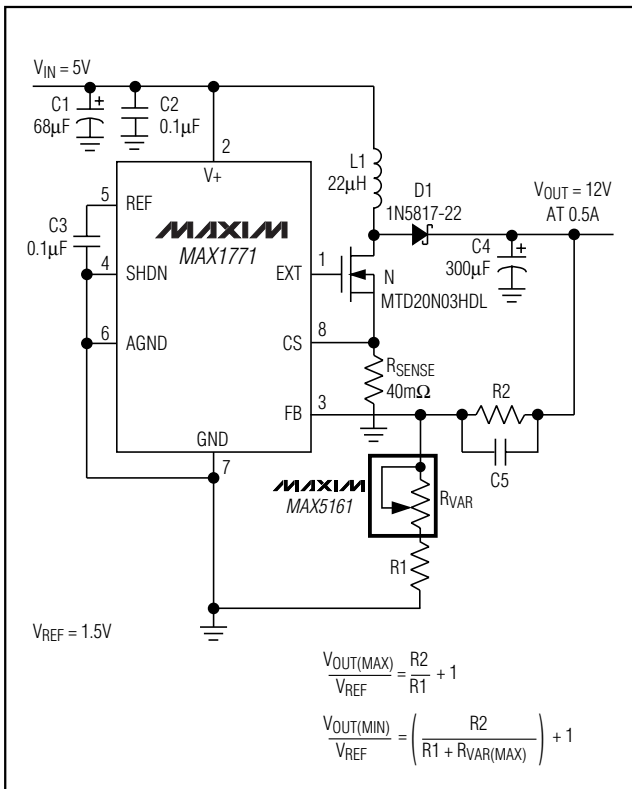

Figure 1. Adjustable Positive LCD Bias

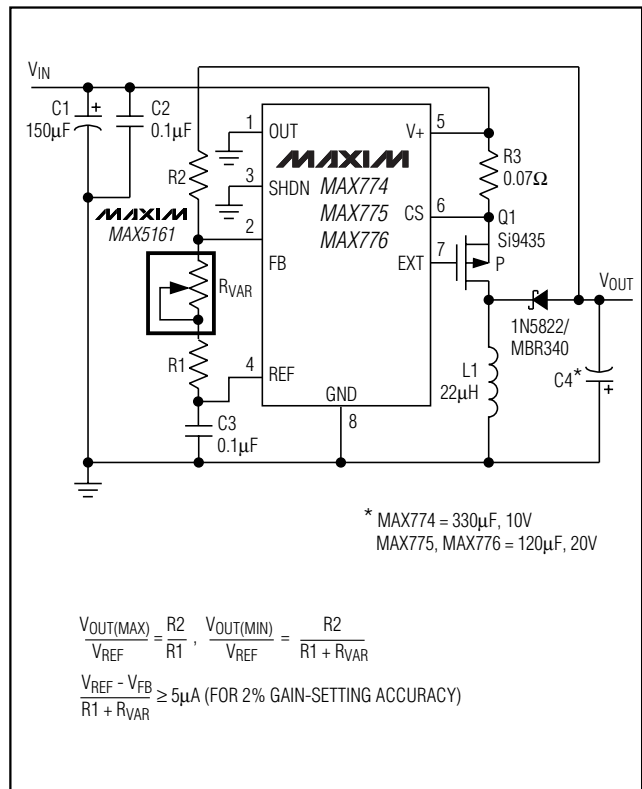

Figure 2. Adjustable Negative LCD Bias

# Low-Power Digital Potentiometers

## Alternative Positive LCD Bias Control

Alternatively, use an op amp to provide buffering and gain to the output of the MAX5160/MAX5161. Connect the MAX5160 to the positive input of a noninverting op amp (Figure 3) to select a portion of the input signal by digitally controlling the wiper terminal. Figure 4 shows a similar circuit for the MAX5161.

## Adjustable Gain

Figure 5 shows how to use the MAX5161 to digitally adjust the gain of a noninverting op amp configuration. Connect the MAX5161 in series with a resistor to ground to form the adjustable gain control of a noninverting amplifier. The MAX5160/MAX5161 have a low 5ppm/°C ratiometric tempco that allows for a very stable adjustable gain configuration over temperature.

## Serial Interface

Figure 6 is the serial-interface timing diagram.

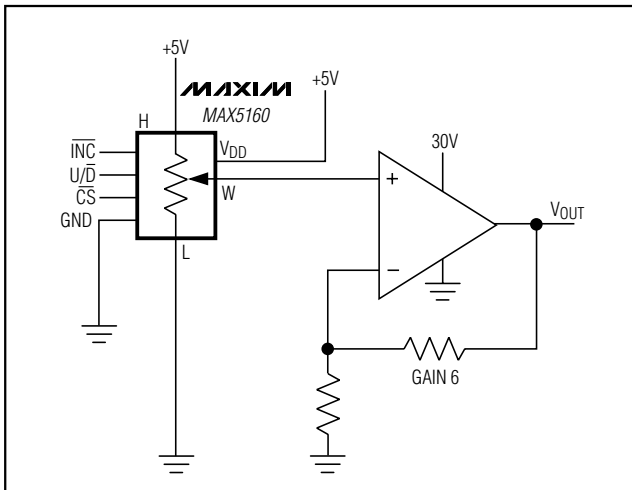

Figure 3. MAX5160 Positive LCD Bias Control

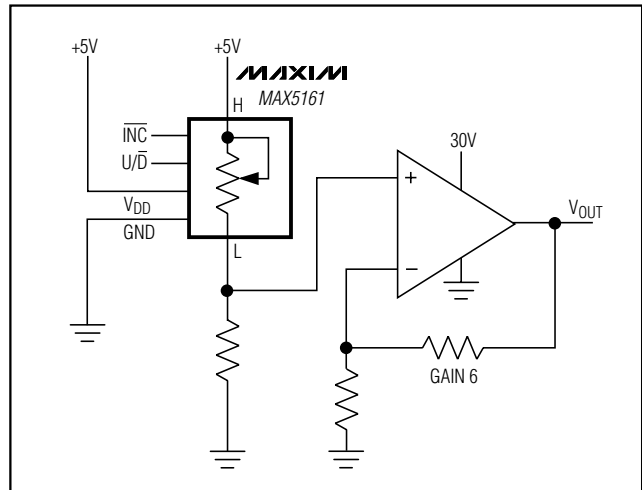

Figure 4. MAX5161 Positive LCD Bias Control



Figure 5. Adjustable Gain Circuit: a) MAX5161; b) MAX5160

# Low-Power Digital Potentiometers

**MAX5160/MAX5161**



Figure 6. Serial-Interface Timing Diagram

## Truth Table

$\overline{CS}$	$U/\overline{D}$	$\overline{INC}$	$R_w$
H	xx-X	X	O
L	L	↑	O
L	H	↑	O
L	L	↓	—
L	H	↓	+

X = Don't care  
 O = Previous state  
 + = Increment  
 — = Decrement  
 ↓ = High-to-Low Transition  
 ↑ = Low-to-High Transition

## Chip Information

TRANSISTOR COUNT: 969

# Low-Power Digital Potentiometers

## Package Information

	INCHES		MILLIMETERS		JEDEC			
	MIN	MAX	MIN	MAX	MIN	MAX	MIN	MAX
A	0.037	0.043	0.94	1.10	---	0.043	---	1.10
A1	0.002	0.006	0.05	0.15	0.002	0.006	0.05	0.15
B	0.010	0.014	0.25	0.36	0.010	0.016	0.25	0.40
C	0.005	0.007	0.13	0.18	0.005	0.009	0.13	0.23
D	0.116	0.120	2.95	3.05	0.114	0.122	2.9	3.1
e	0.0256	BSC	0.65	BSC	0.0256	BSC	0.64	BSC
E	0.116	0.120	2.95	3.05	0.114	0.122	2.9	3.1
H	0.188	0.198	4.78	5.03	0.193	BSC	4.9	BSC
L	0.016	0.026	0.41	0.66	0.016	0.027	0.40	0.70
alpha	0°	6°	0°	6°	0°	6°	0°	6°
S	0.0207	BSC	0.5250	BSC				

NOTES:  
 1. D&E DO NOT INCLUDE MOLD FLASH.  
 2. MOLD FLASH OR PROTRUSIONS NOT TO EXCEED 0.15MM (.006").  
 3. CONTROLLING DIMENSION: MILLIMETERS.  
 4. MEETS JEDEC MO-187.

8LUMAXD.EPS

PROPRIETARY INFORMATION  
 TITLE:  
 PACKAGE OUTLINE, 8L uMAX  
 APPROVAL: \_\_\_\_\_ DOCUMENT CONTROL NO. 21-0036 REV I 1/1



# Low-Power Digital Potentiometers

## Package Information (continued)

MAX5160/MAX5161

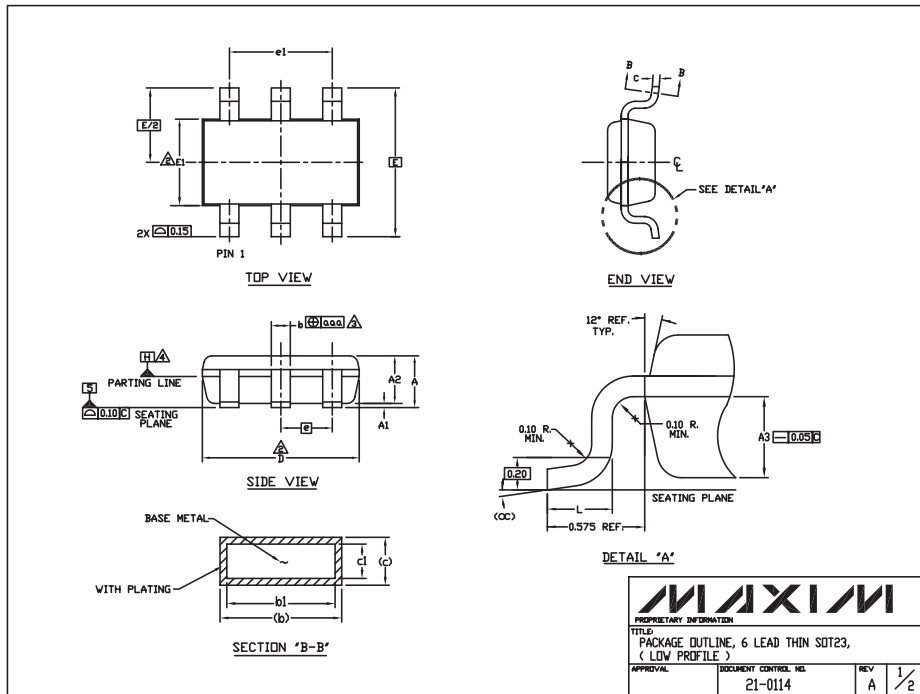

### NOTES:

- ALL DIMENSIONS ARE IN MILLIMETERS.
- "D" AND "E1" ARE REFERENCE DATUM AND DO NOT INCLUDE MOLD FLASH OR PROTRUSIONS, AND ARE MEASURED AT THE BOTTOM PARTING LINE. MOLD FLASH OR PROTRUSION SHALL NOT EXCEED 0.15mm ON "D" AND 0.25mm ON "E" PER SIDE.
- THE LEAD WIDTH DIMENSION DOES NOT INCLUDE DAMBAR PROTRUSION. ALLOWABLE DAMBAR PROTRUSION SHALL BE 0.07mm TOTAL IN EXCESS OF THE LEAD WIDTH DIMENSION AT MAXIMUM MATERIAL CONDITION.
- DATUM PLANE "H" LOCATED AT MOLD PARTING LINE AND COINCIDENT WITH LEAD, WHERE LEAD EXITS PLASTIC BODY AT THE BOTTOM OF PARTING LINE.
- THE LEAD TIPS MUST LINE WITHIN A SPECIFIED TOLERANCE ZONE. THIS TOLERANCE ZONE IS DEFINED BY TWO PARALLEL LINES. ONE PLANE IS THE SEATING PLANE, DATUM [-C-]; AND THE OTHER PLANE IS AT THE SPECIFIED DISTANCE FROM [-C-] IN THE DIRECTION INDICATED. FORMED LEADS SHALL BE PLANAR WITH RESPECT TO ONE ANOTHER WITH 0.10mm AT SEATING PLANE.
- THIS PART IS COMPLIANT WITH JEDEC SPECIFICATION MO-193 EXCEPT FOR THE "e" DIMENSION WHICH IS 0.95mm INSTEAD OF 1.00mm. THIS PART IS IN FULL COMPLIANCE TO EIAJ SPECIFICATION SC-74.

SYMBOLS			
	MIN	NDM	MAX
A	-	-	1.10
A1	0.05	0.075	0.10
A2	0.85	0.88	0.90
A3	0.50 BSC		
b	0.30	-	0.45
b1	0.25	0.35	0.40
c	0.15	-	0.20
c1	0.12	0.127	0.15
D	2.80	2.90	3.00
E	2.75 BSC		
E1	1.55	1.60	1.65
L	0.30	0.40	0.50
e1	1.90 BSC		
e	0.95 BSC		
CC	0°	4°	8°
o.o.o	0.20		

**MAXIM**

PROPRIETARY INFORMATION

TITLE: PACKAGE OUTLINE, 6 LEAD THIN SOT23, (LOW PROFILE)

APPROVAL: [Signature] DOCUMENT CONTROL NO. 21-0114 REV A 2/2

Maxim cannot assume responsibility for use of any circuitry other than circuitry entirely embodied in a Maxim product. No circuit patent licenses are implied. Maxim reserves the right to change the circuitry and specifications without notice at any time.

Maxim Integrated Products, 120 San Gabriel Drive, Sunnyvale, CA 94086 408-737-7600 9

Компания «Океан Электроники» предлагает заключение долгосрочных отношений при поставках импортных электронных компонентов на взаимовыгодных условиях!

Наши преимущества:

- Поставка оригинальных импортных электронных компонентов напрямую с производств Америки, Европы и Азии, а так же с крупнейших складов мира;
- Широкая линейка поставок активных и пассивных импортных электронных компонентов (более 30 млн. наименований);
- Поставка сложных, дефицитных, либо снятых с производства позиций;
- Оперативные сроки поставки под заказ (от 5 рабочих дней);
- Экспресс доставка в любую точку России;
- Помощь Конструкторского Отдела и консультации квалифицированных инженеров;
- Техническая поддержка проекта, помощь в подборе аналогов, поставка прототипов;
- Поставка электронных компонентов под контролем ВП;
- Система менеджмента качества сертифицирована по Международному стандарту ISO 9001;
- При необходимости вся продукция военного и аэрокосмического назначения проходит испытания и сертификацию в лаборатории (по согласованию с заказчиком);
- Поставка специализированных компонентов военного и аэрокосмического уровня качества (Xilinx, Altera, Analog Devices, Intersil, Interpoint, Microsemi, Actel, Aeroflex, Peregrine, VPT, Syfer, Eurofarad, Texas Instruments, MS Kennedy, Miteq, Cobham, E2V, MA-COM, Hittite, Mini-Circuits, General Dynamics и др.);

Компания «Океан Электроники» является официальным дистрибьютором и эксклюзивным представителем в России одного из крупнейших производителей разъемов военного и аэрокосмического назначения «JONHON», а так же официальным дистрибьютором и эксклюзивным представителем в России производителя высокотехнологичных и надежных решений для передачи СВЧ сигналов «FORSTAR».



## JONHON

«JONHON» (основан в 1970 г.)

Разъемы специального, военного и аэрокосмического назначения:

(Применяются в военной, авиационной, аэрокосмической, морской, железнодорожной, горно- и нефтедобывающей отраслях промышленности)

«FORSTAR» (основан в 1998 г.)

ВЧ соединители, коаксиальные кабели, кабельные сборки и микроволновые компоненты:

(Применяются в телекоммуникациях гражданского и специального назначения, в средствах связи, РЛС, а так же военной, авиационной и аэрокосмической отраслях промышленности).



Телефон: 8 (812) 309-75-97 (многоканальный)

Факс: 8 (812) 320-03-32

Электронная почта: [ocean@oceanchips.ru](mailto:ocean@oceanchips.ru)

Web: <http://oceanchips.ru/>

Адрес: 198099, г. Санкт-Петербург, ул. Калинина, д. 2, корп. 4, лит. А