

## Self-Oscillating Half-Bridge Driver

### Features

- Floating channel designed for bootstrap operation
- Integrated 600 V half-bridge gate driver
- 15.6 V zener clamp on Vcc
- True micropower start up
- Tighter initial dead time control
- Low temperature coefficient dead time
- Shutdown feature (1/6th Vcc) on CT pin
- Increased undervoltage lockout Hysteresis (1 V)
- Lower power level-shifting circuit
- Constant LO, HO pulse widths at startup
- Lower di/dt gate driver for better noise immunity
- Low side output in phase with RT
- Excellent latch immunity on all inputs and outputs
- ESD protection on all leads

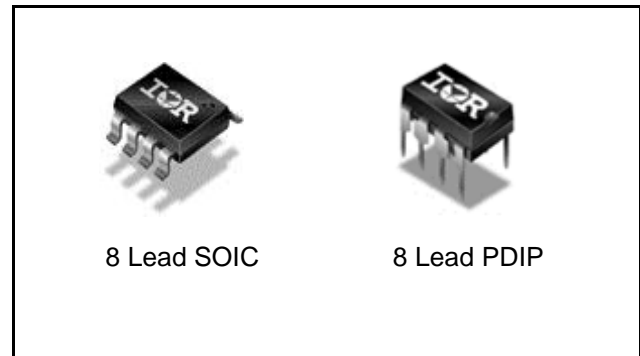
### Description

The IR25603(S) incorporates a high voltage half-bridge gate driver with a front end oscillator similar to the industry standard CMOS 555 timer. A shutdown feature has been designed into the CT pin, so that both gate driver outputs can be disabled using a low voltage control signal. In addition, the gate driver output pulse widths are the same once the rising undervoltage lockout threshold on Vcc has been reached, resulting in a more stable profile of frequency vs time at startup. Special attention has been paid to maximizing the latch immunity of the device and providing comprehensive ESD protection on all pins.

### Product Summary

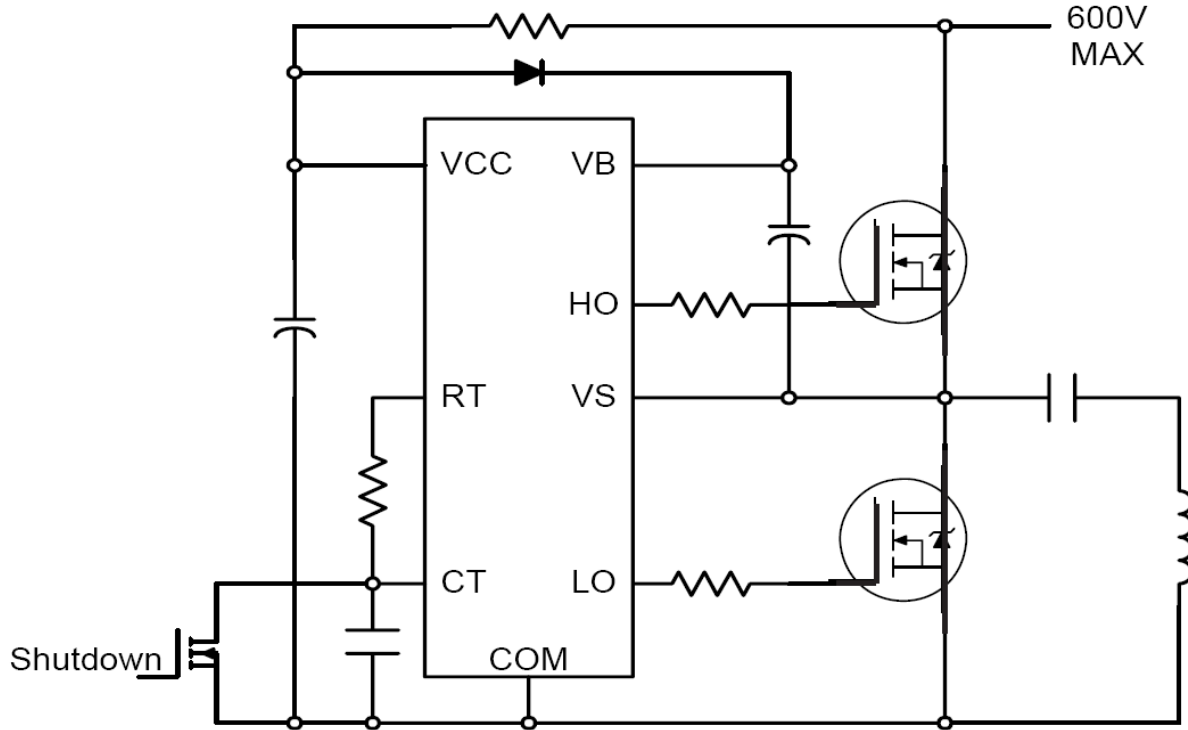
$V_{\text{OFFSET}}$	600 V max.
Duty Cycle	50%
$T_r / T_f$	80 ns / 40 ns
$V_{\text{CLAMP}}$	15.6 V
Dead time (typ.)	1.2 $\mu$ s
$I_{o+}/I_{o-}$ (typ.)	180 mA / 260 mA

### Package Options



### Ordering Information

Base Part Number	Package Type	Standard Pack		Orderable Part Number
		Form	Quantity	
IR25603SPBF	SO8N	Tube	95	IR25603SPBF
IR25603SPBF	SO8N	Tape and Reel	2500	IR25603STRPBF
IR25603PBF	PDIP8	Tube	50	IR25603PBF

**Typical Connection Diagram**


## Absolute Maximum Ratings

Absolute maximum ratings indicate sustained limits beyond which damage to the device may occur. All voltage parameters are absolute voltages referenced to COM, all currents are defined positive into any lead. The thermal resistance and power dissipation ratings are measured under board mounted and still air conditions.

Symbol	Definition	Min.	Max.	Units	
$V_B$	High side floating absolute voltage	-0.3	625	V	
$V_S$	High side floating supply offset voltage	$V_B - 25$	$V_B + 0.3$		
$V_{HO}$	High side floating output voltage	$V_S - 0.3$	$V_B + 0.3$		
$V_{LO}$	Low side output voltage	-0.3	$V_{CC} + 0.3$		
$V_{RT}$	$R_T$ pin voltage	-0.3	$V_{CC} + 0.3$		
$V_{CT}$	$C_T$ pin voltage	-0.3	$V_{CC} + 0.3$		
$I_{CC}$	Supply current†	—	25	mA	
$I_{RT}$	$R_T$ pin current	-5	5		
dVs/dt	Allowable offset supply voltage transient	—	50	V/ns	
$P_D$	Package power dissipation @ $T_A \leq +25^\circ\text{C}$	8 lead PDIP	—	1	W
		8 lead SOIC	—	0.625	
$R_{thJA}$	Thermal resistance, junction to ambient	8 lead PDIP	—	125	$^\circ\text{C}/\text{W}$
		8 lead SOIC	—	200	
$T_J$	Junction temperature	—	150	$^\circ\text{C}$	
$T_S$	Storage temperature	-55	150		
$T_L$	Lead temperature (soldering, 10 seconds)	—	300		

## Recommended Operating Conditions

For proper operation the device should be used within the recommended conditions. The  $V_S$  offset rating is tested with all supplies biased at 15V differential.

Symbol	Definition	Min.	Max.	Units
$V_B$	High side floating supply absolute voltage	$V_{CC} - 0.7$	$V_{CLAMP}$	V
$V_S$	Steady state high side floating supply offset voltage	††	600	
$V_{CC}$	Supply voltage	10	$V_{CLAMP}$	mA
$I_{CC}$	Supply current	†††	5	
$T_A$	Ambient temperature	-40	125	$^\circ\text{C}$

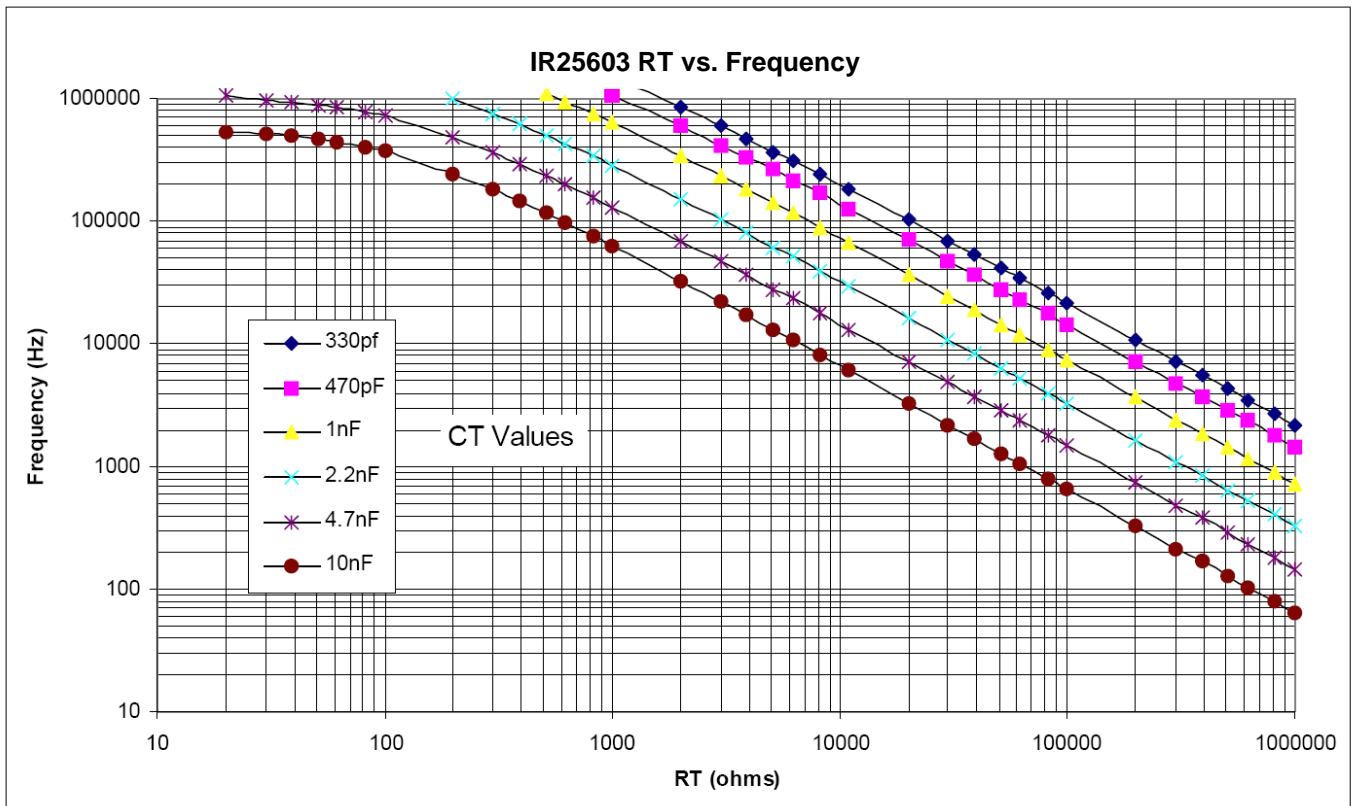
† This IC contains a zener clamp structure between the chip  $V_{CC}$  and COM which has a nominal breakdown voltage of 15.6V. Please note that this supply pin should not be driven by a DC, low impedance power source greater than the  $V_{CLAMP}$  specified in the Electrical Characteristics section.

†† Care should be taken to avoid output switching conditions where the  $V_S$  node flies inductively below ground by more than 5V.

††† Enough current should be supplied to the  $V_{CC}$  pin of the IC to keep the internal 15.6V zener diode clamping the voltage at this pin.

### Recommended Component Values

Symbol	Component	Min.	Max.	Units
$R_T$	Timing resistor value	10	—	$k\Omega$
$C_T$	$C_T$ pin capacitor value	330	—	$\mu F$



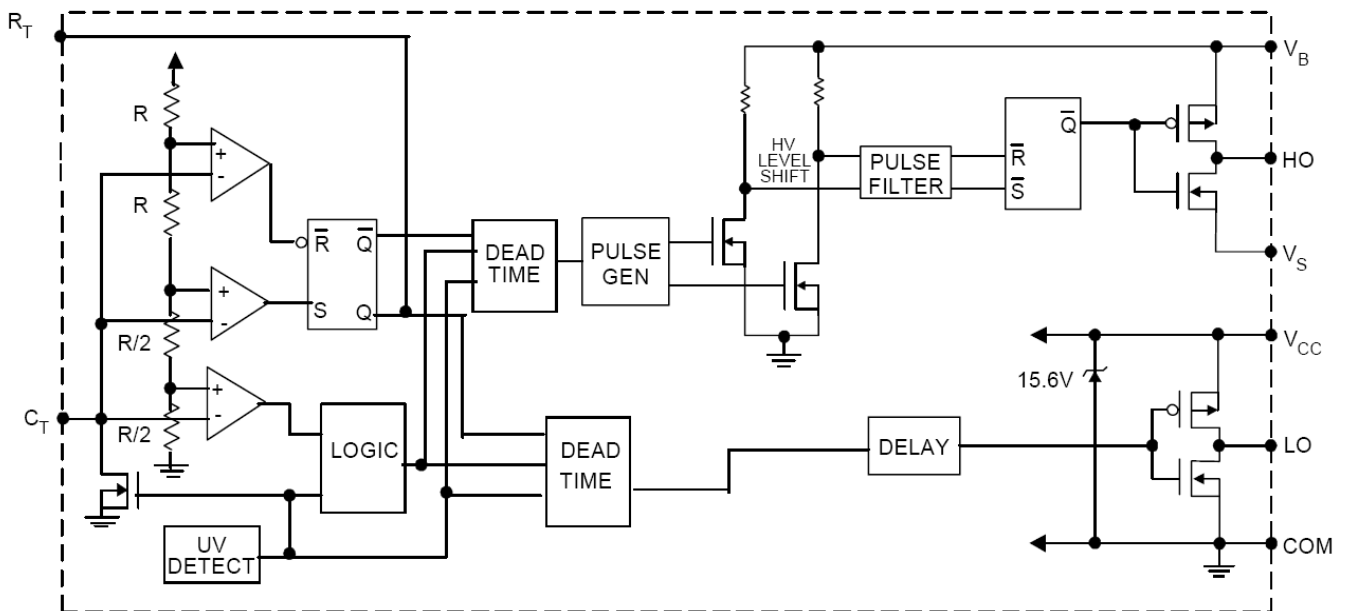
## Electrical Characteristics

$V_{BIAS}$  ( $V_{CC}$ ,  $V_{BS}$ ) = 12V,  $C_L$  = 1000 pF,  $C_T$  = 1nF and  $T_A$  = 25°C unless otherwise specified.

Low Voltage Supply Characteristics						
Symbol	Definition	Min.	Typ.	Max.	Units	Test Conditions
$V_{CCUV+}$	$V_{CC}$ supply undervoltage positive going threshold	8.1	9.0	9.9	V	
$V_{CCUV-}$	$V_{CC}$ supply undervoltage negative going threshold	7.2	8.0	8.8		
$V_{CCUVH}$	$V_{CC}$ undervoltage hysteresis	0.5	1.0	1.5		
$I_{QCCUV}$	Micropower startup $V_{CC}$ supply current	—	75	150	$\mu$ A	$V_{CC} \leq V_{CCUV-}$
$I_{QCC}$	Quiescent $V_{CC}$ supply current	—	500	950		
$V_{CLAMP}$	$V_{CC}$ zener clamp voltage	14.4	15.6	16.8	V	$I_{CC} = 5mA$
Floating Supply Characteristics						
Symbol	Definition	Min.	Typ.	Max.	Units	Test Conditions
$I_{QBSUV}$	Micropower startup $V_{BS}$ supply current	—	0	10	$\mu$ A	$V_{CC} \leq V_{CCUV-}$
$I_{QBS}$	Quiescent $V_{BS}$ supply current	—	30	50		
$V_{BSMIN}$	Minimum required $V_{BS}$ voltage for proper functionality from $R_T$ to HO	—	4.0	5.0	V	$V_{CC} = V_{CCUV+} + 0.1V$
$I_{LK}$	Offset supply leakage current	—	—	50	$\mu$ A	$V_B = V_S = 600V$
Oscillator I/O Characteristics						
Symbol	Definition	Min.	Typ.	Max.	Units	Test Conditions
$f_{OSC}$	Oscillator frequency	19.4	20	20.6	kHz	$R_T = 36.9k\Omega$
		94	100	106		$R_T = 7.43k\Omega$
$d$	$R_T$ pin duty cycle	48	50	52	%	$f_O < 100kHz$
$I_{CT}$	$C_T$ pin current	—	0.001	1.0	$\mu$ A	
$I_{CTUV}$	UV-mode $C_T$ pin pull down current	0.3	0.7	1.2	mA	$V_{CC} = 7V$
$V_{CT+}$	Upper $C_T$ ramp voltage threshold	—	8	—	V	
$V_{CT-}$	Lower $C_T$ ramp voltage threshold	—	4	—		
$V_{CTSD}$	$C_T$ voltage shutdown threshold	1.8	2.1	2.4		
$V_{RT+}$	High-level $R_T$ output voltage, $V_{CC} - V_{RT}$	—	10	50	mV	$I_{RT} = 100 \mu A$
		—	100	300		$I_{RT} = 1mA$
$V_{RT-}$	Low-level $R_T$ output voltage	—	10	50		$I_{RT} = 100 \mu A$
		—	100	300		$I_{RT} = 1mA$
$V_{RTUV}$	UV-mode $R_T$ output voltage	—	0	100		$V_{CC} \leq V_{CCUV-}$
$V_{RTSD}$	SD-Mode $R_T$ output voltage, $V_{CC} - V_{RT}$	—	10	50		$I_{RT} = 100 \mu A$ , $V_{CT} = 0V$
		—	10	300		$I_{RT} = 1mA$ , $V_{CT} = 0V$

**Electrical Characteristics (cont.)**

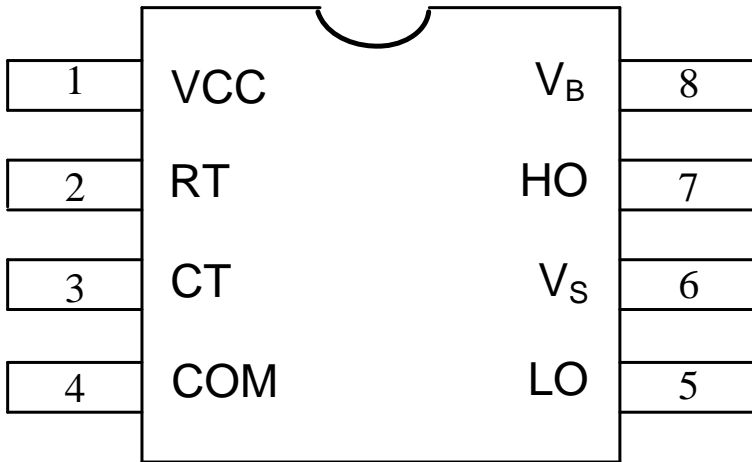
Gate Driver Output Characteristics						
Symbol	Definition	Min.	Typ.	Max.	Units	Test Conditions
VOH	High level output voltage, $V_{BIAS} - V_O$	—	0	100	mV	$I_O = 0A$
VOL	Low-level output voltage, $V_O$	—	0	100		$I_O = 0A$
VOL_UV	UV-mode output voltage, $V_O$	—	0	100		$I_O = 0A$ $V_{CC} \leq V_{CCUV-}$
$t_r$	Output rise time	—	80	150	ns	
$t_f$	Output fall time	—	45	100		
$t_{sd}$	Shutdown propagation delay	—	660	—		
$t_d$	Output dead time (HO or LO)	0.75	1.20	1.65	$\mu s$	
$I_{O+}$	Output source current	—	180	—	mA	
$I_{O-}$	Output sink current	—	260	—		

**Functional Block Diagram**


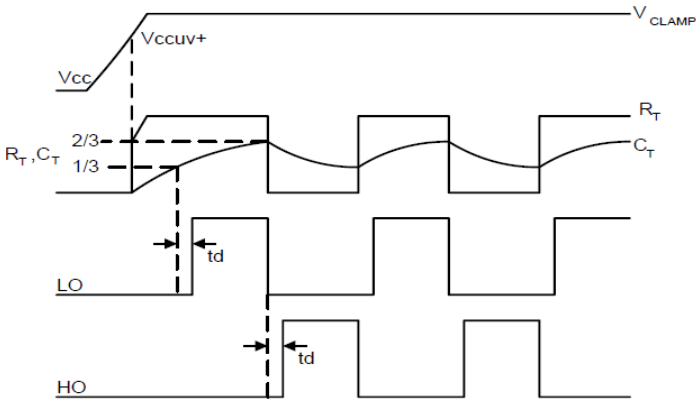
### Lead Definitions

Symbol	Description
V <sub>CC</sub>	Logic and internal gate drive supply voltage
R <sub>T</sub>	Oscillator timing resistor input
C <sub>T</sub>	Oscillator timing capacitor input
COM	IC power and signal ground
LO	Low side gate driver output
V <sub>S</sub>	High voltage floating supply return
HO	High side gate driver output
V <sub>B</sub>	High side gate driver floating supply

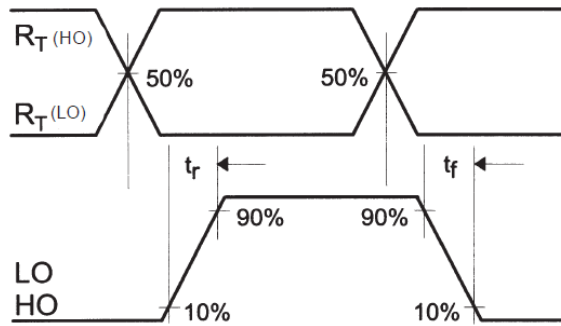
### Lead Assignments



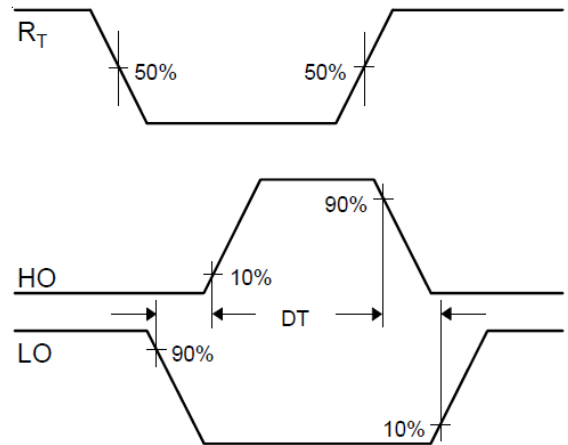
**Application Information and Additional Details**



**Figure 1. Input/Output Timing Diagram**

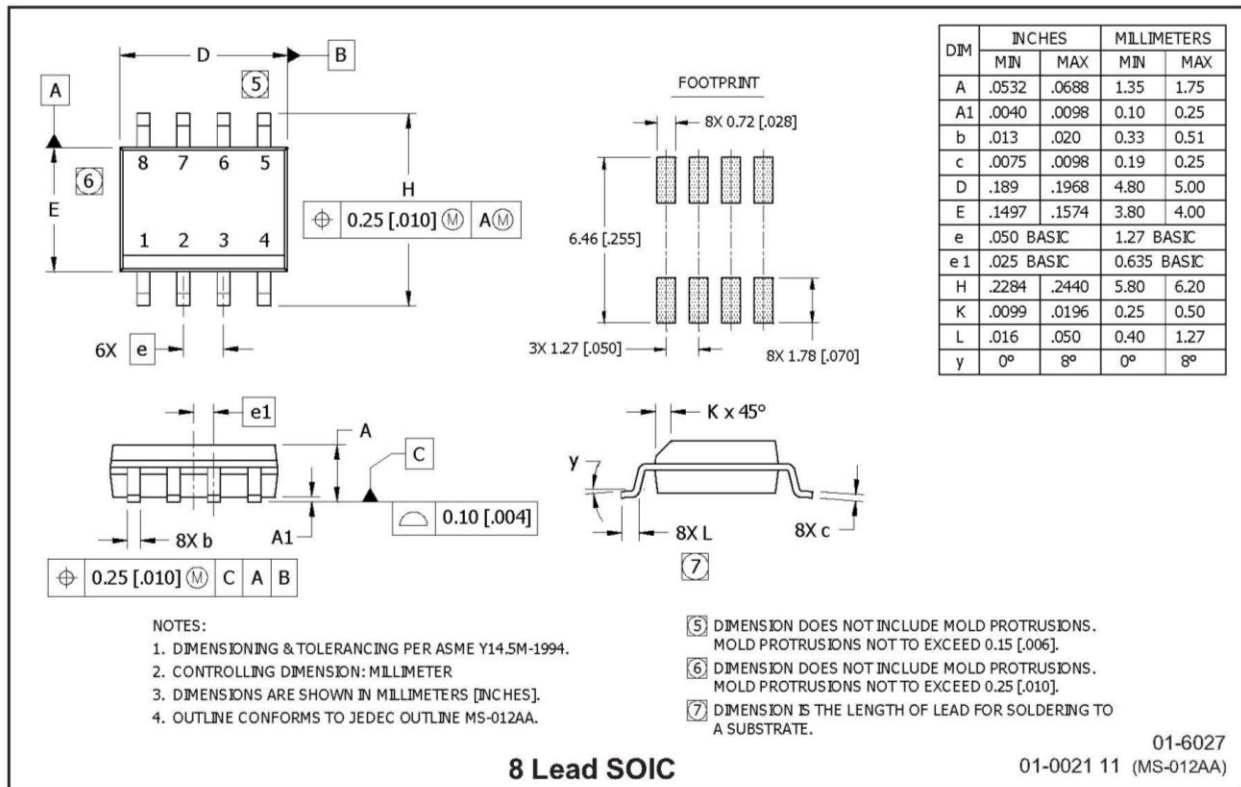
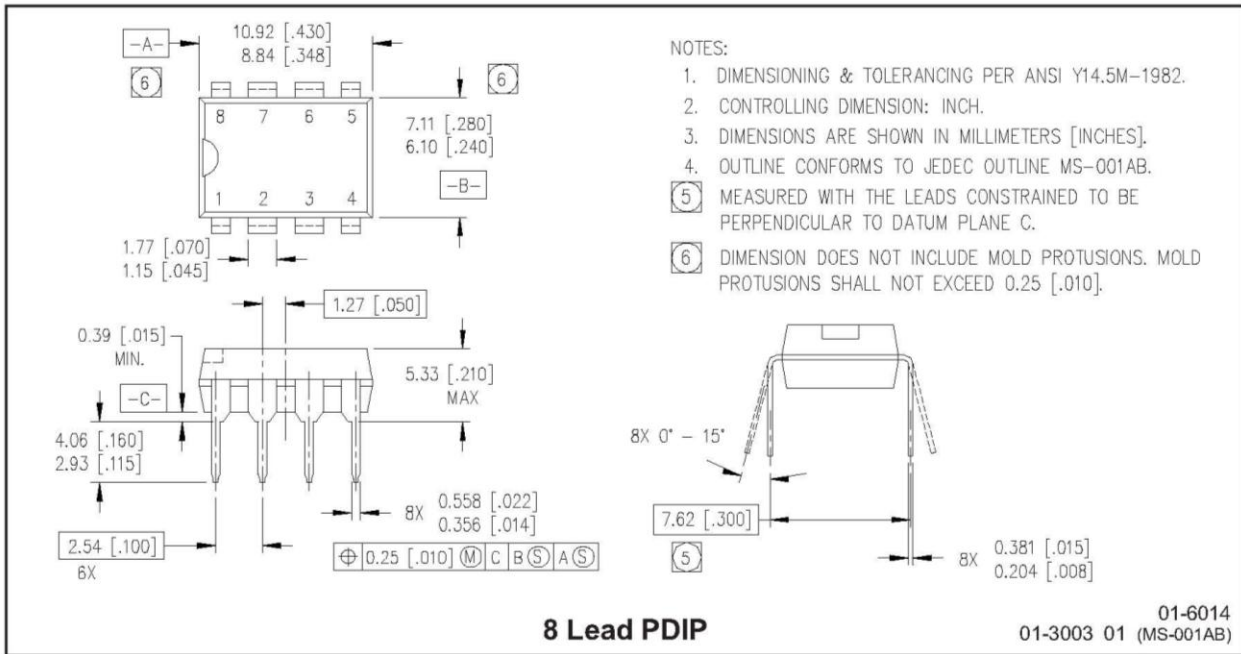


**Figure 2. Switching Time Waveform Definitions**

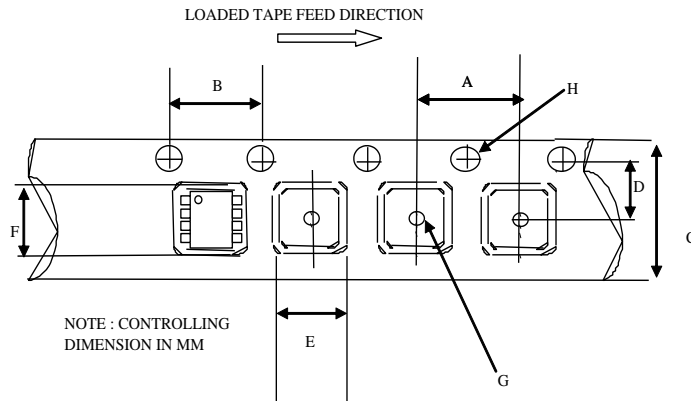


**Figure 3. Deadtime Waveform Definitions**



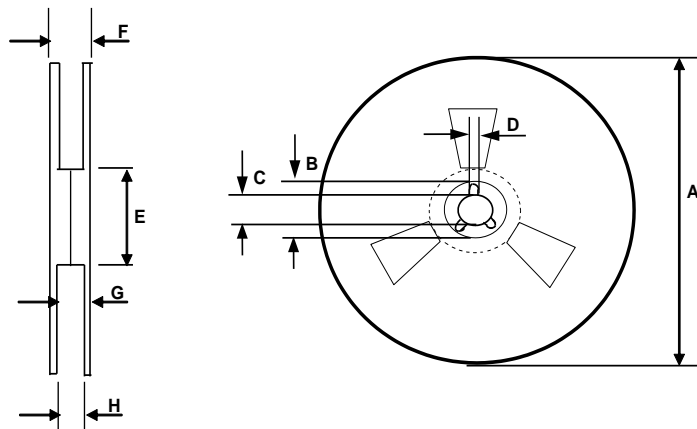
**Package Details**


### Tape and Reel Details, SO8N



CARRIER TAPE DIMENSION FOR 8SOICN

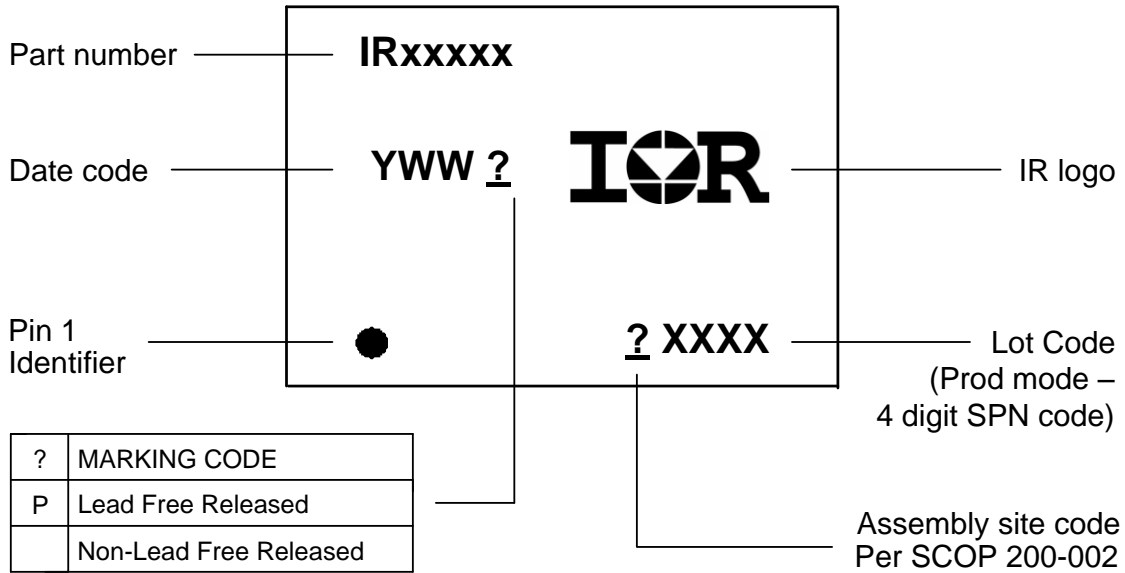
Code	Metric		Imperial	
	Min	Max	Min	Max
A	7.90	8.10	0.311	0.318
B	3.90	4.10	0.153	0.161
C	11.70	12.30	0.46	0.484
D	5.45	5.55	0.214	0.218
E	6.30	6.50	0.248	0.255
F	5.10	5.30	0.200	0.208
G	1.50	n/a	0.059	n/a
H	1.50	1.60	0.059	0.062



REEL DIMENSIONS FOR 8SOICN

Code	Metric		Imperial	
	Min	Max	Min	Max
A	329.60	330.25	12.976	13.001
B	20.95	21.45	0.824	0.844
C	12.80	13.20	0.503	0.519
D	1.95	2.45	0.767	0.096
E	98.00	102.00	3.858	4.015
F	n/a	18.40	n/a	0.724
G	14.50	17.10	0.570	0.673
H	12.40	14.40	0.488	0.566

**Part Marking Information**



**Qualification Information<sup>†</sup>**

<b>Qualification Level</b>	Industrial <sup>††</sup> (per JEDEC JESD 47)	
	Comments: This family of ICs has passed JEDEC's Industrial qualification. IR's Consumer qualification level is granted by extension of the higher Industrial level.	
<b>Moisture Sensitivity Level</b>	SOIC8N	MSL2 <sup>†††</sup> (per IPC/JEDEC J-STD 020)
	PDIP8	Not applicable (non-surface mount package style)
<b>RoHS Compliant</b>	Yes	

† Qualification standards can be found at International Rectifier's web site <http://www.irf.com/>

†† Higher qualification ratings may be available should the user have such requirements. Please contact your International Rectifier sales representative for further information.

††† Higher MSL ratings may be available for the specific package types listed here. Please contact your International Rectifier sales representative for further information.

The information provided in this document is believed to be accurate and reliable. However, International Rectifier assumes no responsibility for the consequences of the use of this information. International Rectifier assumes no responsibility for any infringement of patents or of other rights of third parties which may result from the use of this information. No license is granted by implication or otherwise under any patent or patent rights of International Rectifier. The specifications mentioned in this document are subject to change without notice. This document supersedes and replaces all information previously supplied.

For technical support, please contact IR's Technical Assistance Center  
<http://www.irf.com/technical-info/>

**WORLD HEADQUARTERS:**  
 233 Kansas St., El Segundo, California 90245  
 Tel: (310) 252-7105

Компания «Океан Электроники» предлагает заключение долгосрочных отношений при поставках импортных электронных компонентов на взаимовыгодных условиях!

Наши преимущества:

- Поставка оригинальных импортных электронных компонентов напрямую с производств Америки, Европы и Азии, а так же с крупнейших складов мира;
- Широкая линейка поставок активных и пассивных импортных электронных компонентов (более 30 млн. наименований);
- Поставка сложных, дефицитных, либо снятых с производства позиций;
- Оперативные сроки поставки под заказ (от 5 рабочих дней);
- Экспресс доставка в любую точку России;
- Помощь Конструкторского Отдела и консультации квалифицированных инженеров;
- Техническая поддержка проекта, помощь в подборе аналогов, поставка прототипов;
- Поставка электронных компонентов под контролем ВП;
- Система менеджмента качества сертифицирована по Международному стандарту ISO 9001;
- При необходимости вся продукция военного и аэрокосмического назначения проходит испытания и сертификацию в лаборатории (по согласованию с заказчиком);
- Поставка специализированных компонентов военного и аэрокосмического уровня качества (Xilinx, Altera, Analog Devices, Intersil, Interpoint, Microsemi, Actel, Aeroflex, Peregrine, VPT, Syfer, Eurofarad, Texas Instruments, MS Kennedy, Miteq, Cobham, E2V, MA-COM, Hittite, Mini-Circuits, General Dynamics и др.);

Компания «Океан Электроники» является официальным дистрибьютором и эксклюзивным представителем в России одного из крупнейших производителей разъемов военного и аэрокосмического назначения «JONHON», а так же официальным дистрибьютором и эксклюзивным представителем в России производителя высокотехнологичных и надежных решений для передачи СВЧ сигналов «FORSTAR».



## JONHON

«JONHON» (основан в 1970 г.)

Разъемы специального, военного и аэрокосмического назначения:

(Применяются в военной, авиационной, аэрокосмической, морской, железнодорожной, горно- и нефтедобывающей отраслях промышленности)

«FORSTAR» (основан в 1998 г.)

ВЧ соединители, коаксиальные кабели, кабельные сборки и микроволновые компоненты:

(Применяются в телекоммуникациях гражданского и специального назначения, в средствах связи, РЛС, а так же военной, авиационной и аэрокосмической отраслях промышленности).



Телефон: 8 (812) 309-75-97 (многоканальный)

Факс: 8 (812) 320-03-32

Электронная почта: [ocean@oceanchips.ru](mailto:ocean@oceanchips.ru)

Web: <http://oceanchips.ru/>

Адрес: 198099, г. Санкт-Петербург, ул. Калинина, д. 2, корп. 4, лит. А