

OSLON Black Series (810 nm) - 80° Preliminary Version 0.0

SFH 4703AS

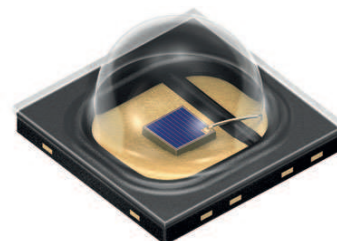

Features:

- IR lightsource with high efficiency
- Double stack emitter
- Low thermal resistance (Max. 16 K/W)
- Centroid wavelength 810 nm
- Superior Corrosion Robustness (see chapter package outlines)

Applications

- Infrared Illumination for cameras
- Surveillance systems
- Machine vision systems
- Eye tracking systems
- Iris Scanning

Notes

Depending on the mode of operation, these devices emit highly concentrated non visible infrared light which can be hazardous to the human eye. Products which incorporate these devices have to follow the safety precautions given in IEC 60825-1 and IEC 62471.

Ordering Information

Type:	Radiant Intensity I_e [mW/sr] $I_F = 1 \text{ A}, t_p = 10 \text{ ms}$	Ordering Code
SFH 4703AS	630 (≥ 500)	Q65112A1370

Note: measured at a solid angle of $\Omega = 0.01 \text{ sr}$

Maximum Ratings ($T_A = 25\text{ °C}$)

Parameter	Symbol	Values	Unit
Operating temperature range	T_{op}	-40 ... 125	°C
Storage temperature range	T_{stg}	-40 ... 125	°C
Junction temperature	T_j	145	°C
Reverse voltage	V_R	5	V
Forward current	I_F	1000	mA
Surge current ($t_p \leq 200\ \mu\text{s}$, $D = 0$)	I_{FSM}	2	A
Power consumption	P_{tot}	4	W
Thermal resistance junction - solder point	R_{thJS}	16	K / W
ESD withstand voltage (acc. to ANSI/ ESDA/ JEDEC JS-001 - HBM)	V_{ESD}	2	kV

Note: For the forward current and power consumption please see "maximum permissible forward current" diagram

Characteristics ($T_A = 25\text{ °C}$)

Parameter	Symbol	Values	Unit
Peak wavelength ($I_F = 1\text{ A}$, $t_p = 10\text{ ms}$)	(typ) λ_{peak}	820	nm
Centroid wavelength ($I_F = 1\text{ A}$, $t_p = 10\text{ ms}$)	(typ) $\lambda_{centroid}$	810	nm
Spectral bandwidth at 50% of I_{max} ($I_F = 1\text{ A}$, $t_p = 10\text{ ms}$)	(typ) $\Delta\lambda$	30	nm
Half angle	(typ) φ	± 40	°
Dimensions of active chip area	(typ) L x W	0.75 x 0.75	mm x mm
Rise and fall times of I_e (10% and 90% of $I_{e,max}$) ($I_F = 1\text{ A}$, $R_L = 50\ \Omega$)	(typ) t_r / t_f	8 / 14	ns
Forward voltage ($I_F = 1\text{ A}$, $t_p = 10\text{ ms}$)	(typ (max)) V_F	3.55 (≤ 4)	V
Forward voltage ($I_F = 2\text{ A}$, $t_p = 100\ \mu\text{s}$)	(typ (max)) V_F	4 (≤ 4.9)	V
Reverse current ($V_R = 5\text{ V}$)	I_R	not designed for reverse operation	μA
Total radiant flux ($I_F = 1\text{ A}$, $t_p = 100\ \mu\text{s}$)	(typ) Φ_e	1040	mW

Parameter		Symbol	Values	Unit
Total radiant flux ($I_F = 1 \text{ A}$, $t_p = 10 \text{ ms}$)	(typ)	Φ_e	1000	mW
Temperature coefficient of I_e or Φ_e ($I_F = 1 \text{ A}$, $t_p = 10 \text{ ms}$)	(typ)	TC_I	-0.3	% / K
Temperature coefficient of V_F ($I_F = 1 \text{ A}$, $t_p = 10 \text{ ms}$)	(typ)	TC_V	-2	mV / K
Temperature coefficient of wavelength ($I_F = 1 \text{ A}$, $t_p = 10 \text{ ms}$)	(typ)	TC_λ	0.3	nm / K

Grouping ($T_A = 25 \text{ }^\circ\text{C}$)

Group	Min Radiant Intensity	Max Radiant Intensity
	$I_F = 1 \text{ A}$, $t_p = 10 \text{ ms}$ $I_{e, \min}$ [mW / sr]	$I_F = 1 \text{ A}$, $t_p = 10 \text{ ms}$ $I_{e, \max}$ [mW / sr]
SFH4703AS - DB	500	800
SFH4703AS - EA	630	1000

Note: measured at a solid angle of $\Omega = 0.01 \text{ sr}$

Only one group in one packing unit (variation lower 1.6:1).

Relative Spectral Emission ^{1) page 13}

$I_{rel} = f(\lambda)$, $T_A = 25\text{ }^\circ\text{C}$, $I_F = 1\text{ A}$, $t_p = 10\text{ ms}$

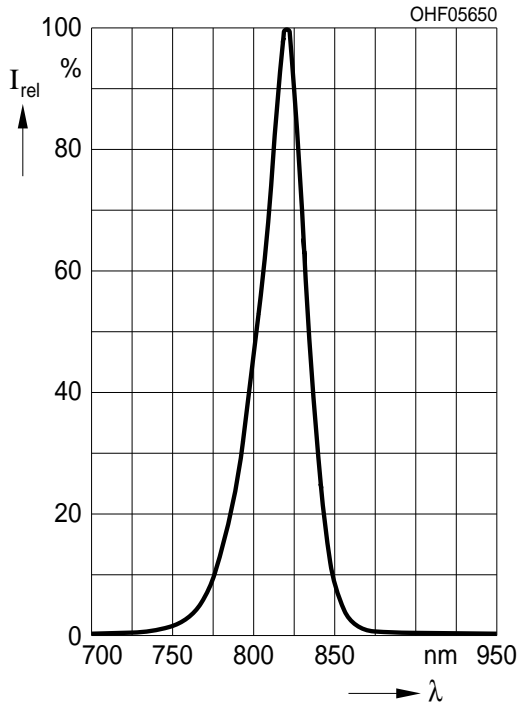

Radiant Intensity ^{1) page 13}

$I_e / I_e(1\text{ A}) = f(I_F)$, single pulse, $t_p = 100\text{ }\mu\text{s}$, $T_A = 25\text{ }^\circ\text{C}$

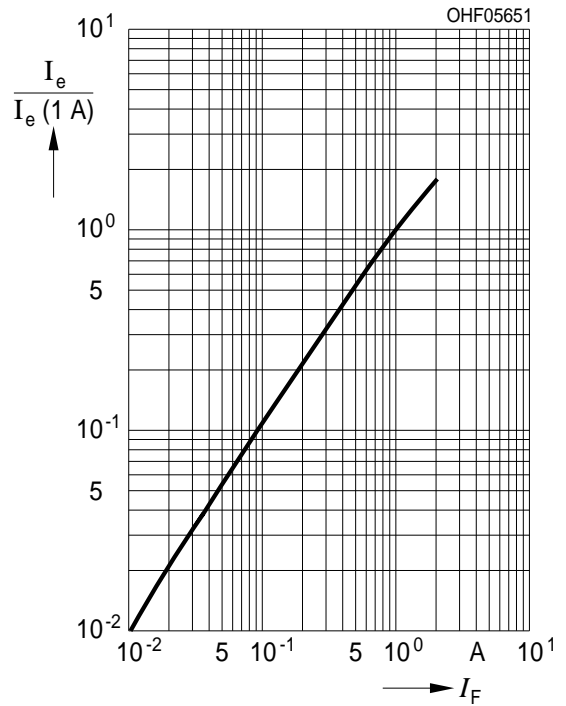

Max. Permissible Forward Current

$I_F = f(T_S)$, $R_{thJS} = 16\text{ K/W}$

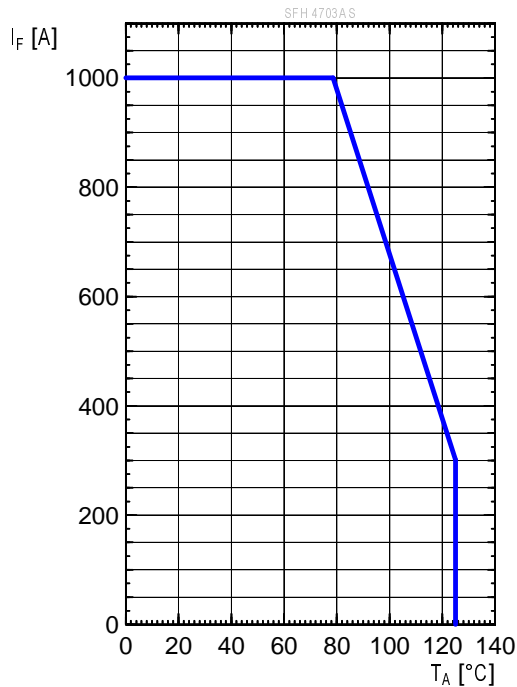

Forward Current ^{1) page 13}

$I_F = f(V_F)$, single pulse, $t_p = 100\text{ }\mu\text{s}$, $T_A = 25\text{ }^\circ\text{C}$

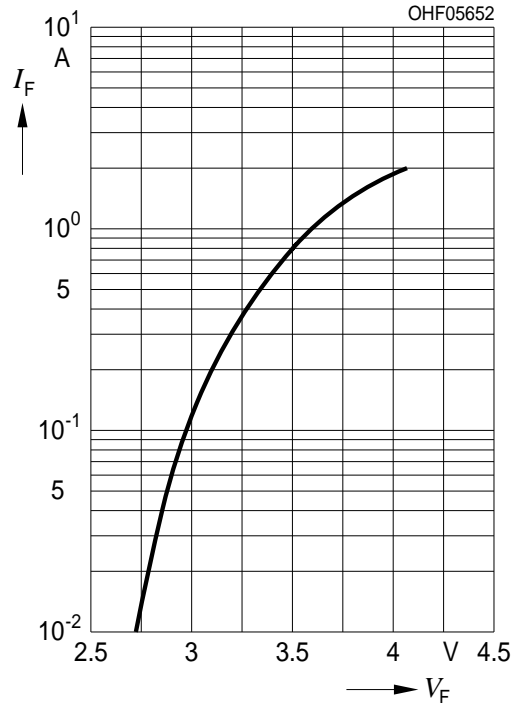

Permissible Pulse Handling Capability

$I_F = f(t_p)$, $T_S = 25\text{ °C}$, Duty cycle $D = \text{parameter}$

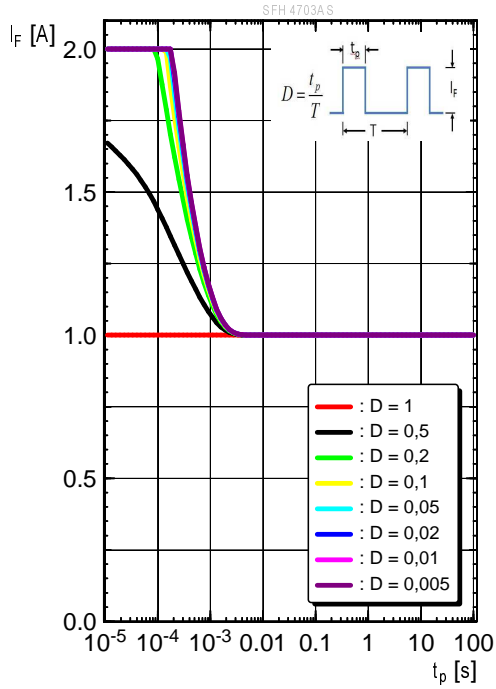

Permissible Pulse Handling Capability

$I_F = f(t_p)$, $T_S = 85\text{ °C}$, duty cycle $D = \text{parameter}$

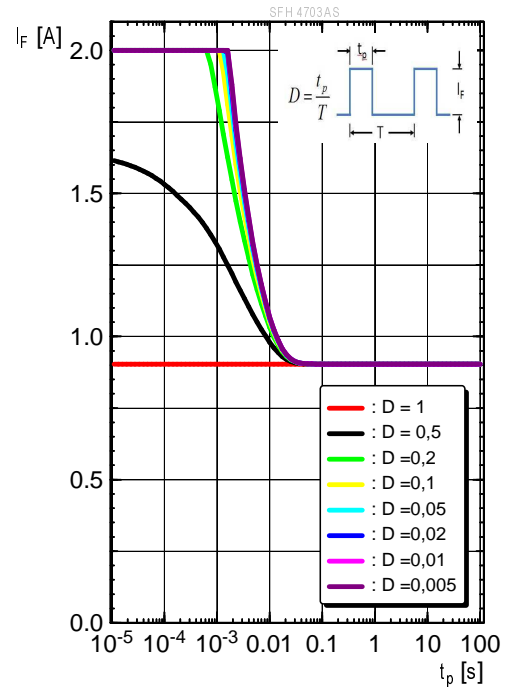

Radiation Characteristics ^{1) page 13}

$I_{rel} = f(\phi)$, $T_A = 25\text{ °C}$

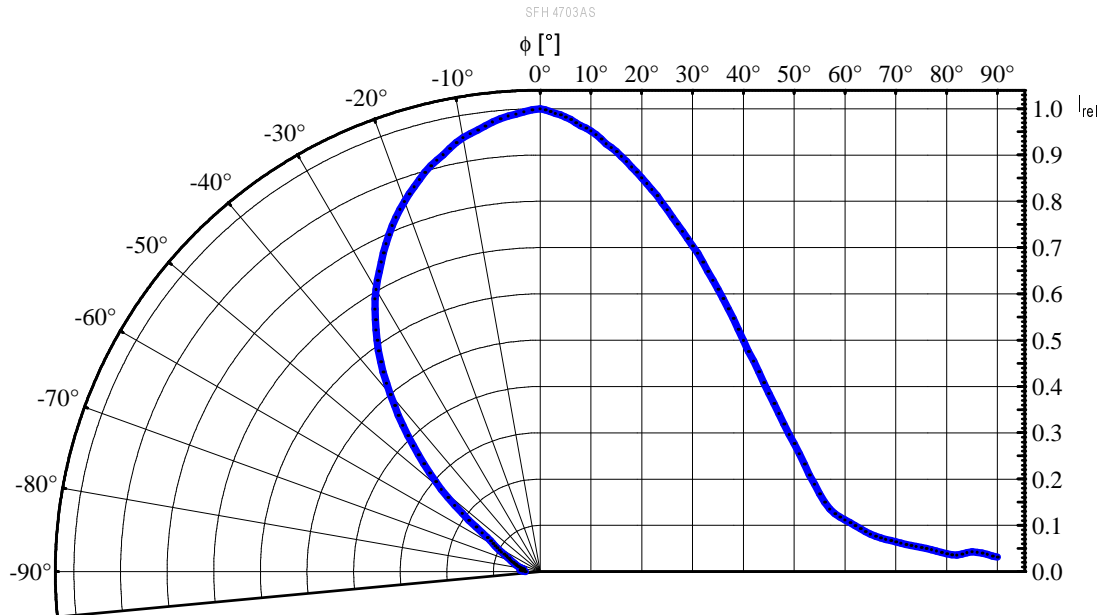

Package Outline

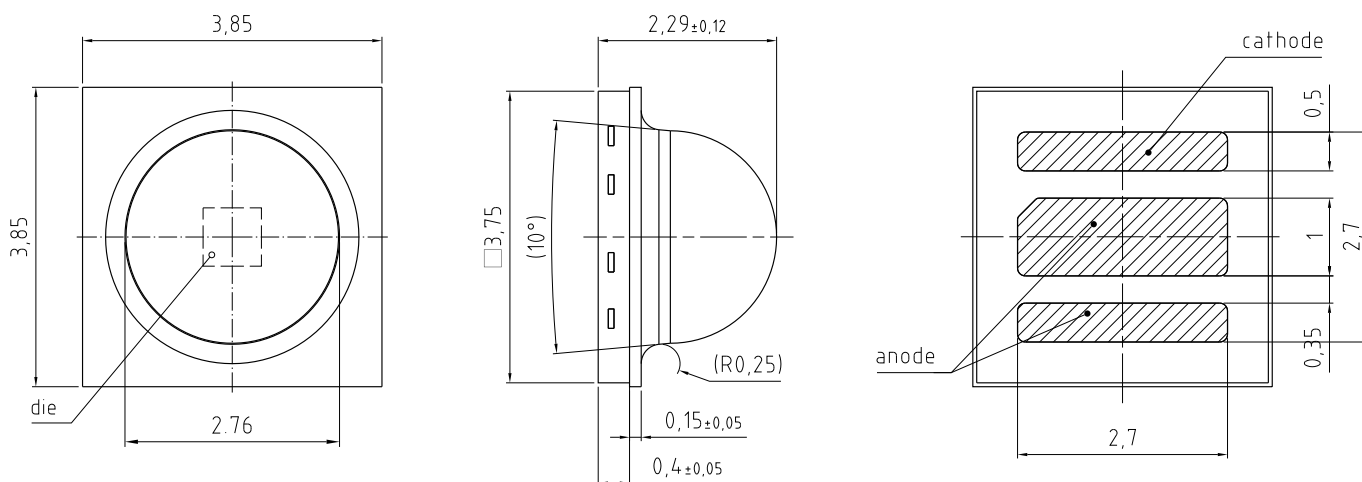

general tolerance ± 0.1

lead finish Au

C63062-A4141-A9 -02

Dimensions in mm.

Package

OSLON Black Series

Approximate Weight:

31 mg

Note:

Package is not suitable for ultra sonic cleaning.

Note:

Corrosion robustness better than EN 60068-2-60 (method 4): with enhanced corrosion test: 40°C / 90%rh / 15ppm H₂S / 336h

Note:

Anode mark: Anode pad has chamfered edge, which points to cathode

Recommended Solder Pad

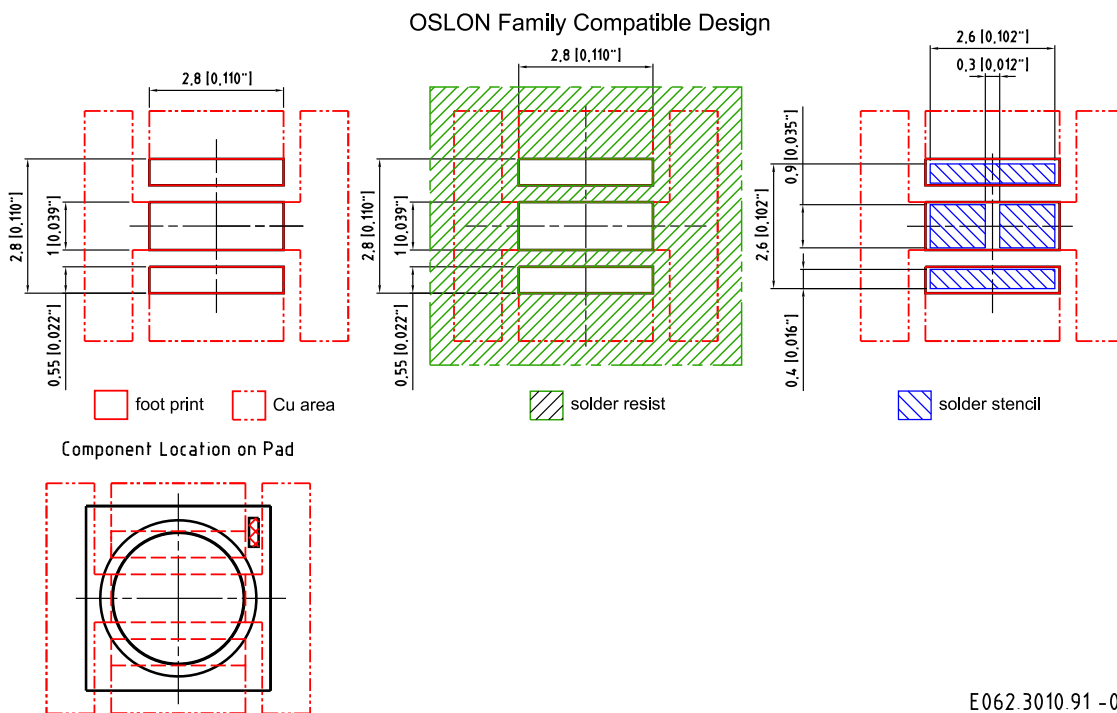

E062.3010.91 -05

Dimensions in mm [inch].

Note:

For superior solder joint connectivity results we recommend soldering under standard nitrogen atmosphere.

Reflow Soldering Profile

Product complies to MSL Level 2 acc. to JEDEC J-STD-020E

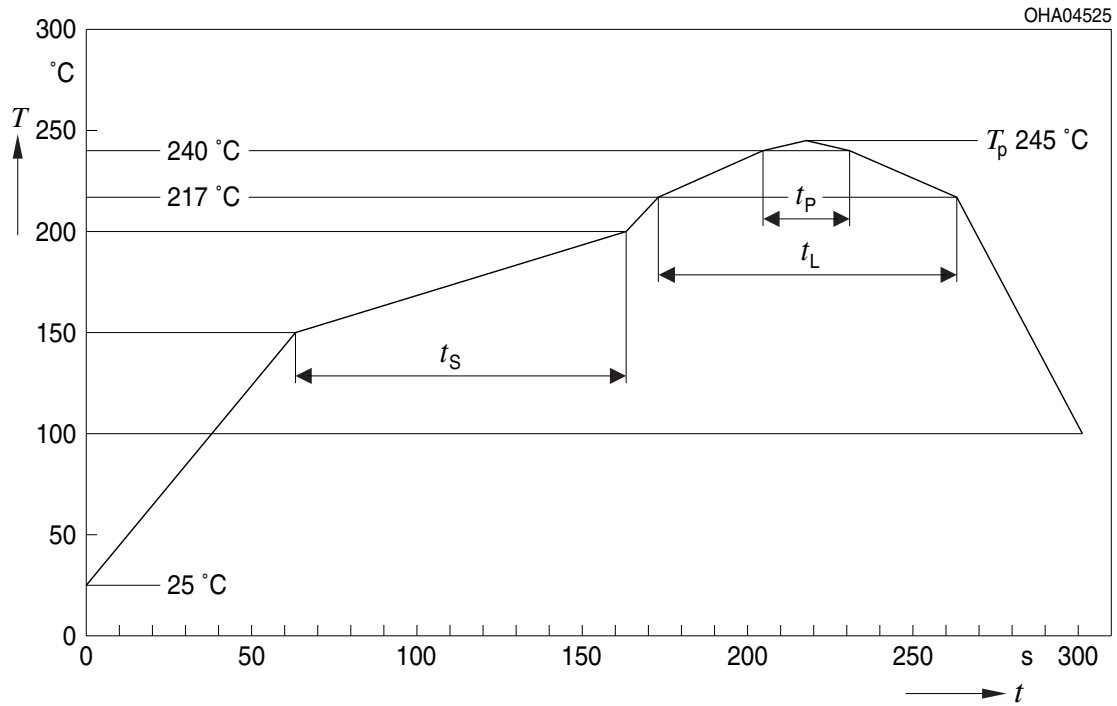

OHA04612

Profile Feature Profil-Charakteristik	Symbol Symbol	Pb-Free (SnAgCu) Assembly			Unit Einheit
		Minimum	Recommendation	Maximum	
Ramp-up rate to preheat*) 25 °C to 150 °C			2	3	K/s
Time t_s T_{Smin} to T_{Smax}	t_s	60	100	120	s
Ramp-up rate to peak*) T_{Smax} to T_p			2	3	K/s
Liquidus temperature	T_L	217			°C
Time above liquidus temperature	t_L		80	100	s
Peak temperature	T_p		245	260	°C
Time within 5 °C of the specified peak temperature $T_p - 5$ K	t_p	10	20	30	s
Ramp-down rate* T_p to 100 °C			3	6	K/s
Time 25 °C to T_p				480	s

All temperatures refer to the center of the package, measured on the top of the component
 * slope calculation DT/Dt : Dt max. 5 s; fulfillment for the whole T-range

Taping

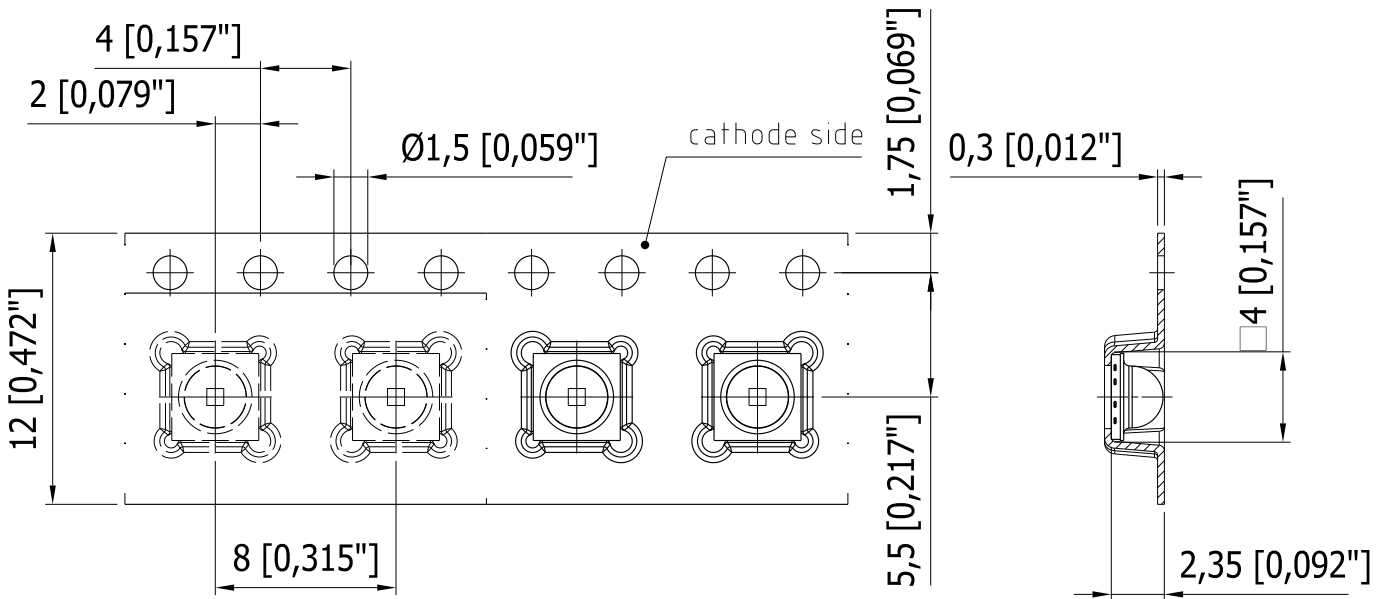

C63062-A4068-B12 -02

Dimensions in mm [inch].

Tape and Reel

12 mm tape with 600 pcs. on Ø 180 mm reel

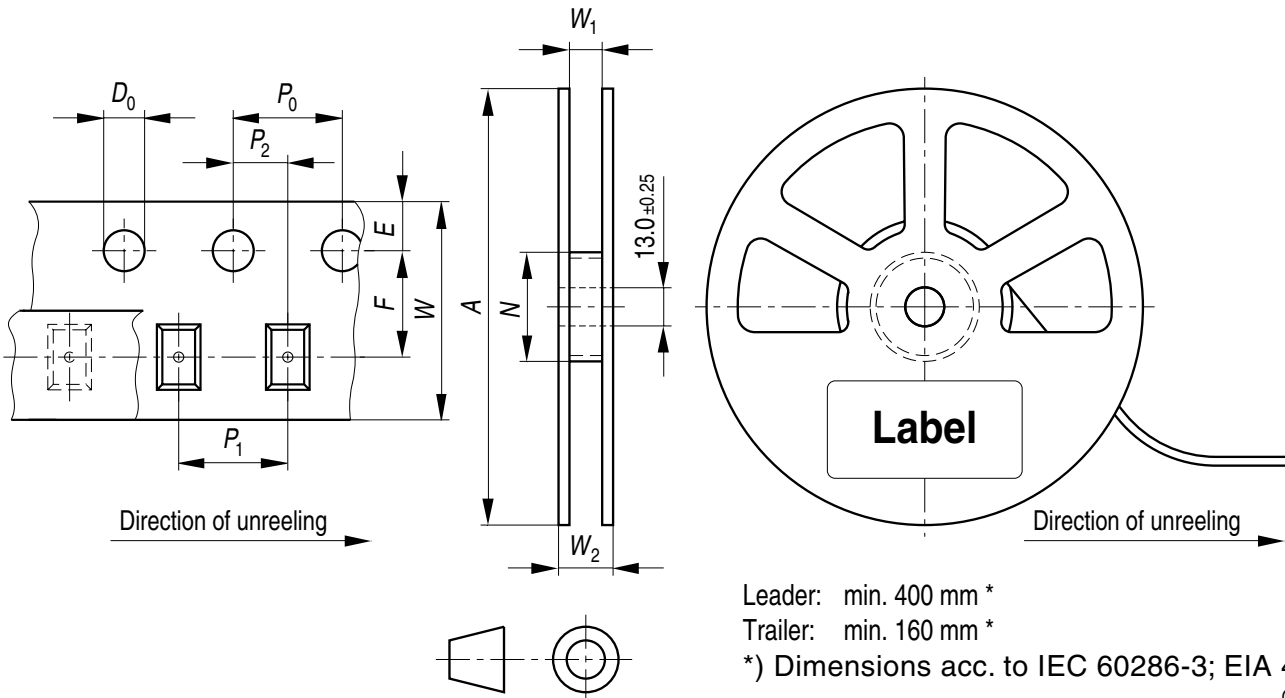

Leader: min. 400 mm *

Trailer: min. 160 mm *

*) Dimensions acc. to IEC 60286-3; EIA 481-D

OHAY0324

Tape dimensions [mm]

W	P ₀	P ₁	P ₂	D ₀	E	F
12 + 0.3 / - 0.1	4 ± 0.1	4 ± 0.1 or 8 ± 0.1	2 ± 0.05	1.5 ± 0.1	1.75 ± 0.1	5.5 ± 0.05

Reel dimensions [mm]

A	W	N _{min}	W ₁	W _{2max}
180	12	60	12.4 + 2	18.4

Barcode-Product-Label (BPL)



Dry Packing Process and Materials

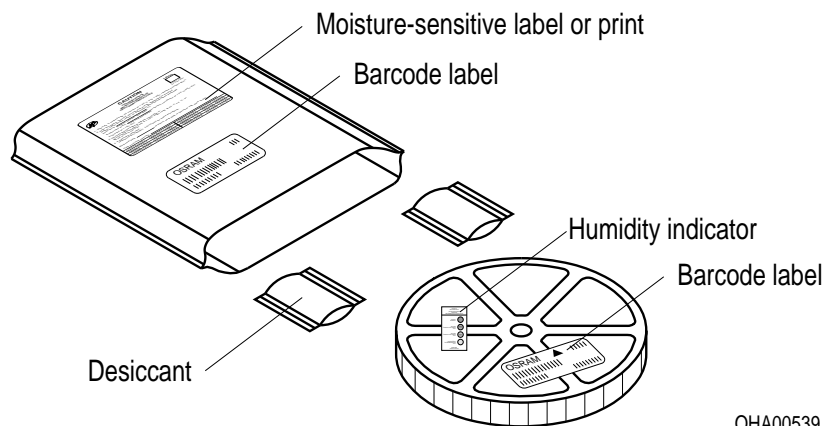

Note:

Moisture-sensitive product is packed in a dry bag containing desiccant and a humidity card. Regarding dry pack you will find further information in the internet. Here you will also find the normative references like JEDEC.

Transportation Packing and Materials

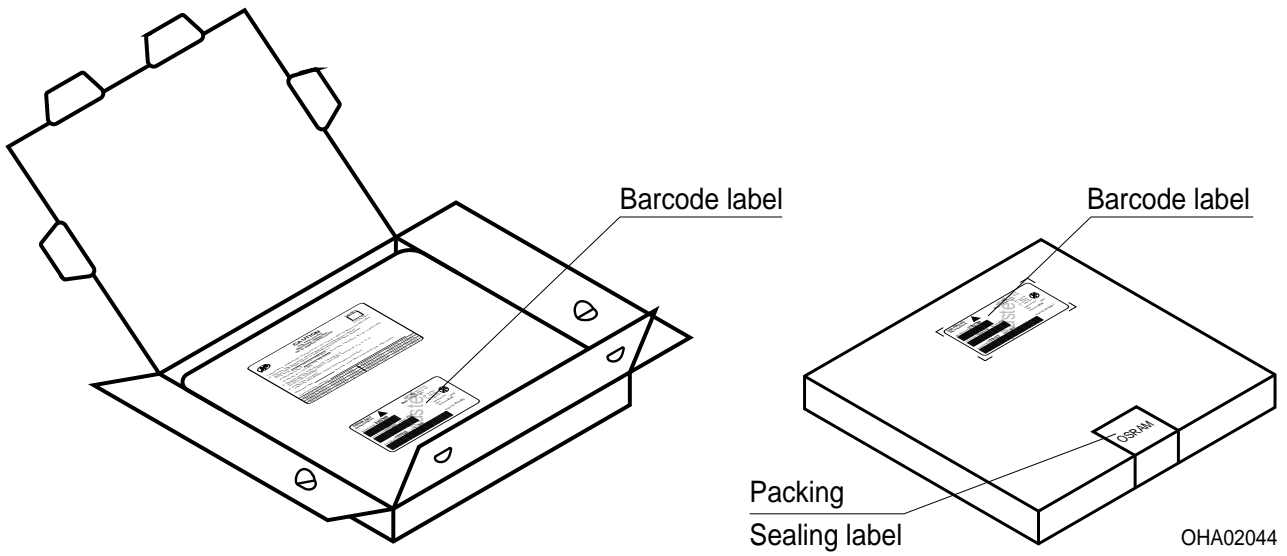

Dimensions of transportation box in mm

Width	Length	Height
195 ± 5	195 ± 5	30 ± 5

Disclaimer

OSRAM OS assumes no liability whatsoever for any use of this document or its content by recipient including, but not limited to, for any design in activities based on this preliminary draft version. OSRAM OS may e.g. decide at its sole discretion to stop developing and/or finalising the underlying design at any time.

Language english will prevail in case of any discrepancies or deviations between the two language wordings.

Attention please!

The information describes the type of component and shall not be considered as assured characteristics.

Terms of delivery and rights to change design reserved. Due to technical requirements components may contain dangerous substances.

For information on the types in question please contact our Sales Organization.

If printed or downloaded, please find the latest version in the Internet.

Packing

Please use the recycling operators known to you. We can also help you – get in touch with your nearest sales office. By agreement we will take packing material back, if it is sorted. You must bear the costs of transport. For packing material that is returned to us unsorted or which we are not obliged to accept, we shall have to invoice you for any costs incurred.

Components used in life-support devices or systems must be expressly authorized for such purpose!

Critical components* may only be used in life-support devices** or systems with the express written approval of OSRAM OS.

*) A critical component is a component used in a life-support device or system whose failure can reasonably be expected to cause the failure of that life-support device or system, or to affect its safety or the effectiveness of that device or system.

**) Life support devices or systems are intended (a) to be implanted in the human body, or (b) to support and/or maintain and sustain human life. If they fail, it is reasonable to assume that the health and the life of the user may be endangered.

Glossary

- ¹⁾ **Typical Values:** Due to the special conditions of the manufacturing processes of LED, the typical data or calculated correlations of technical parameters can only reflect statistical figures. These do not necessarily correspond to the actual parameters of each single product, which could differ from the typical data and calculated correlations or the typical characteristic line. If requested, e.g. because of technical improvements, these typ. data will be changed without any further notice.

Published by OSRAM Opto Semiconductors GmbH
Leibnizstraße 4, D-93055 Regensburg
www.osram-os.com © All Rights Reserved.

EU RoHS and China RoHS compliant product



此产品符合欧盟 RoHS 指令的要求；
按照中国的相关法规和标准，不含有毒有害物质或元素。

Компания «Океан Электроники» предлагает заключение долгосрочных отношений при поставках импортных электронных компонентов на взаимовыгодных условиях!

Наши преимущества:

- Поставка оригинальных импортных электронных компонентов напрямую с производств Америки, Европы и Азии, а так же с крупнейших складов мира;
- Широкая линейка поставок активных и пассивных импортных электронных компонентов (более 30 млн. наименований);
- Поставка сложных, дефицитных, либо снятых с производства позиций;
- Оперативные сроки поставки под заказ (от 5 рабочих дней);
- Экспресс доставка в любую точку России;
- Помощь Конструкторского Отдела и консультации квалифицированных инженеров;
- Техническая поддержка проекта, помощь в подборе аналогов, поставка прототипов;
- Поставка электронных компонентов под контролем ВП;
- Система менеджмента качества сертифицирована по Международному стандарту ISO 9001;
- При необходимости вся продукция военного и аэрокосмического назначения проходит испытания и сертификацию в лаборатории (по согласованию с заказчиком);
- Поставка специализированных компонентов военного и аэрокосмического уровня качества (Xilinx, Altera, Analog Devices, Intersil, Interpoint, Microsemi, Actel, Aeroflex, Peregrine, VPT, Syfer, Eurofarad, Texas Instruments, MS Kennedy, Miteq, Cobham, E2V, MA-COM, Hittite, Mini-Circuits, General Dynamics и др.);

Компания «Океан Электроники» является официальным дистрибьютором и эксклюзивным представителем в России одного из крупнейших производителей разъемов военного и аэрокосмического назначения «JONHON», а так же официальным дистрибьютором и эксклюзивным представителем в России производителя высокотехнологичных и надежных решений для передачи СВЧ сигналов «FORSTAR».



JONHON

«JONHON» (основан в 1970 г.)

Разъемы специального, военного и аэрокосмического назначения:

(Применяются в военной, авиационной, аэрокосмической, морской, железнодорожной, горно- и нефтедобывающей отраслях промышленности)

«FORSTAR» (основан в 1998 г.)

ВЧ соединители, коаксиальные кабели, кабельные сборки и микроволновые компоненты:

(Применяются в телекоммуникациях гражданского и специального назначения, в средствах связи, РЛС, а так же военной, авиационной и аэрокосмической отраслях промышленности).



Телефон: 8 (812) 309-75-97 (многоканальный)

Факс: 8 (812) 320-03-32

Электронная почта: ocean@oceanchips.ru

Web: <http://oceanchips.ru/>

Адрес: 198099, г. Санкт-Петербург, ул. Калинина, д. 2, корп. 4, лит. А