

Solid-state Relay Provides Three Operating Functions in a Compact Package

- Prevents burnouts in 3-phase induction motors due to overcurrent, open-phase, or reverse-phase.
- LEDs indicate operation of the selected operating function.
- Wide setting ranges: current: 1 to 160 A; operating time: 1 to 40 s.
- Protects the motor from reversing without starting it.



The SE cannot be used with circuits with distorted waveforms, inverter circuits, or capacitor loads.



Model Number Structure

Model Number Legend

SE-K□□□□□N

1 2 3 4 5 6 7 8

1. Basic model name

SE: Motor Protective Relay

2. Protective functions

K: Three possible operating functions: overcurrent, open-phase, or reverse-phase protection

3. Operating time characteristics for overload element

Q: Instantaneous type: Fixed time at starting and instantaneous during operation

None: Inverse type: Inverse operation both at starting and during operation

4. Case

P: Plug-in type

None: Flush mount type

5. Control voltage

1: 100/110/120 VAC

2: 200/220/240 VAC

4: 380/400/440 VAC

6. Reset method

None: Manual reset

A: Automatic reset

7. Operating value

None: 115% of the current SV

E: 100% of the current SV

8. Product history

N: New version

Note: A 3-phase transformer (sold separately) must be used to operate Plug-in Relays at 380, 400, 415, or 440 VAC. Drop the primary voltage (380 to 440 VAC) to a 200-VAC secondary voltage before applying it to the SE-KP2EN or SE-KQP2EN.

Ordering Information

SE-□EN

Overcurrent operating value: 100% of the current SV.

Terminal/mounting	Control voltage	Reset	Model	
			Inverse type	Instantaneous type (See note.)
Plug-in terminal/DIN rail via socket	100/110/120 VAC	Manual	SE-KP1EN	SE-KQP1EN
	200/220/240 VAC		SE-KP2EN	SE-KQP2EN
Screw terminal/flush mount	100/110/120 VAC		SE-K1EN	SE-KQ1EN
	200/220/240 VAC		SE-K2EN	SE-KQ2EN
	380/400/440 VAC		SE-K4EN	SE-KQ4EN

Note: With start-up lock: fixed time-limit on start-up, instantaneous thereafter.
Plug-in type requires a socket (8PFA1) which is sold separately.
Refer to page 9 for the mounting conditions.

SE-□□N

Overcurrent operating value: 115% of current SV.

Control voltage	Reset	Model	
		Inverse type	Instantaneous type (See note 1.)
100/110 120 VAC	Manual	SE-KP1N	SE-KQP1N
	Automatic	SE-KP1AN	SE-KQP1AN
200/220/240 VAC	Manual	SE-KP2N	SE-KQP2N
	Automatic	SE-KP2AN	SE-KQP2AN
100/110/120 VAC	Manual	SE-K1N	SE-KQ1N
	Automatic	SE-K1AN	SE-KQ1AN
200/220/240 VAC	Manual	SE-K2N	SE-KQ2N
	Automatic	SE-K2AN	SE-KQ2AN
380/400/440 VAC	Manual	SE-K4N	SE-KQ4N
	Automatic	---	---

Note: 1. With start-up lock: fixed time-limit on start-up, instantaneous thereafter.**2.** The operating value for the overload detection function of the SE-□□N is 115% of the current SV.**■ Accessories (Order Separately)****Current Converters**

Model	Current range
SET-3A	1 to 80 A
SET-3B	64 to 160 A

DIN rail socket
8PFA1

3-phase TransformerSpecify the primary voltage when ordering.
Only one SE relay can be connected.

Model	Voltage specification		Secondary power consumption
SE-PT400	Primary side	380 to 480 V (wide power supply range)	7 VA
	Secondary side	190 to 240 V (wide power supply range)	

Adapter

Model
SE-F7AD

This Adapter is used to replace existing flush mount models with new models.

Specifications**■ Ratings**

Motor circuit	Voltage: 500 VAC max. 3-phase (primary voltage at SET current converter) Current: 1 to 80 A or 64 to 160 A 3-phase (primary current at SET current converter)
Power supply circuit	Voltage: 100/110/120 VAC, 200/220/240 VAC, or 380/400/440 VAC 3-phase (treat as a single phase voltage when the reverse-phase function is not needed) Voltage fluctuation: +10/-15% max. of the rated voltage (+10/-50% max. for open-phase function) Frequency: 50/60 Hz ±5%
Current SV range	See table of <i>Current Converter</i> .
Output relay contact	Configuration: SPDT Capacity: Refer to the table below.
Power consumption	100/110/120 VAC: approx. 3.5 VA; 200/220/240 VAC: approx. 7 VA; 380/400/440 VAC: approx. 11 VA
Case color	Plug-in model: Munsell 5Y7/1 Panel-mount model: Munsell N1.5

Output Contact Capacity

Control power supply	Contact	Manual reset	Automatic reset
100/110/120 VAC or 200/220/240 VAC	NO	3 A (cosφ = 1.0)/1.5 A (cosφ = 0.3 to 0.4) at 240 VAC	3 A (cosφ = 1.0)/2 A (cosφ = 0.4) at 240 VAC
	NC	3 A (cosφ = 1.0)/2 A (cosφ = 0.3 to 0.4) at 240 VAC	
380/400/440 VAC	NO	3 A (cosφ = 1.0)/1.5 A (cosφ = 0.3 to 0.4) at 440 VAC	---
	NC	3 A (cosφ = 1.0)/2 A (cosφ = 0.3 to 0.4) at 440 VAC	

■ Characteristics

Item		Inverse type	Instantaneous type
Overcurrent	Operating value	100% of the current SV (SE-□□EN) 115% of the current SV (SE-□□□N)	
	Operating time characteristics	Inverse time both at starting and during operation	Fixed time at start-up and instantaneous during operation
	Operating time	For an overcurrent of 600%: Time scale × 1: 1 to 10 s Time scale × 4: 4 to 40 s For an overcurrent of 200%: 2.8 × t, where t is the time at 600% overcurrent. (time SV at max.: 10 s or 40 s)	In fixed time mode (start-up mode) with an overcurrent of 600%: Time scale × 1: 1 to 10 s Time scale × 4: 4 to 40 s In instantaneous mode: 0.5 s max. at 140% overcurrent
	Initial current in start-up mode	---	Operates when the current is about 30% of the set current
	Inertial characteristics	At the min. current SV and max. time SV, will not operate for 80% of the operating time for a 600% overcurrent.	---
Open-phase	Operating value: Less than 50% of the current SV (at open-phase) Operating unbalance: At high sensitivity (H): 35 ±10%; At low sensitivity (L): 65 ±10% (The unbalance for a max. 3-phase current equal to the current SV) Operating time: At high sensitivity (H): 2 s max.; At low sensitivity (L): 3 ±1 s (Open-phase current equal to the current SV)		
Reverse-phase	Operating value: 80% max. of the rated voltage Operating time: 0.5 s max. at the rated voltage		
Overcurrent SV accuracy	Operating value: ±10% of max. current SV Operating time: $^{+10}/_{-5}$ % of max. time SV (at a time SV: 1), +10% of max. time SV (at a time SV: 2 to 10) (start-up lock)		
Influence of temperature (overcurrent)	Operating value: ±5% for 0 to 40°C; ±10% for -10 to 50°C Operating time: ±10% for 0 to 40°C; ±20% for -10 to 50°C (start-up lock)		
Influence of frequency (overcurrent)	Operating value: ±3% for a frequency fluctuation of ±5% Operating time: ±5% for a frequency fluctuation of ±5% (start-up lock)		
Influence of voltage (overcurrent)	Operating value: ±3% for a voltage fluctuation of $^{+10}/_{-15}$ % Operating time: ±5% for a voltage fluctuation of $^{+10}/_{-15}$ % (start-up lock)		
Insulation resistance	10 MΩ min. between the entire electric circuits and the mounting panel 5 MΩ min. between contact circuits, or between contacts of same pole		
Withstand voltage	Refer to the table below.		
Lighting impulse withstand voltage	6000 V max. between the entire circuits and the mounting panel 4500 V max. between contact circuits, or across contacts Waveform: 1.2/50 μs		
Overload capacity	Motor circuit: 20 times the current SV for 2 s, applied twice with a 1 min interval Control voltage: 1.15 times the rated control voltage for 3 hrs		
Life Expectancy	10,000 operations min. (non-conducting contacts)		
Vibration resistance	Malfunction: 10 to 55 Hz, 0.3-mm double amplitude each in 3 directions for 10 minutes Destruction: 10 to 25 Hz, 2-mm double amplitude each in 3 directions for 2 hours		
Shock resistance	Malfunction: 98 m/s ² (approx. 10G) each in 3 directions Destruction: 294 m/s ² (approx. 30G) each in 3 directions		
Test button operation	Operated quickly (without lighting the LED)		
Ambient temperature	Operating: -10 to 60°C (with no icing) Storage: -25 to 65°C (with no icing)		
Ambient humidity	Operating: 35% to 85%		
Altitude	2,000 m max.		
Weight	Approx. 170 to 230 g		

Dielectric Strength

Test Area	Control voltage		
	100/110/120 VAC	200/220/240 VAC	380/400/440 VAC
Between electric circuits and the mounting panel	2,000 VAC for 1 min		2,500 VAC for 1 min
Between contact circuits and other circuits	2,000 VAC for 1 min		2,500 VAC for 1 min
Between each pair of contacts	1,000 VAC for 1 min		1,000 VAC for 1 min

Engineering Data

Operating Characteristics

Overcurrent Operating Time Characteristics (Inverse Type)

Overcurrent Operating Time Characteristics (Instantaneous Type - Start-up Lock)

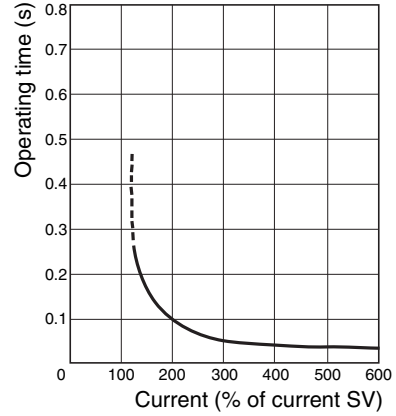
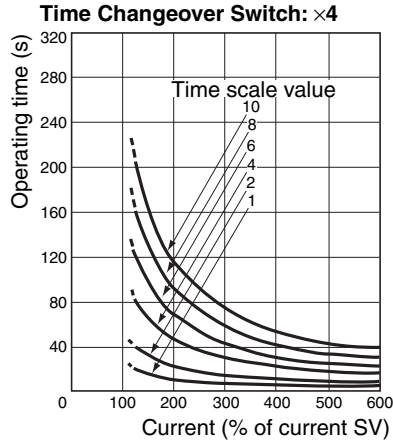
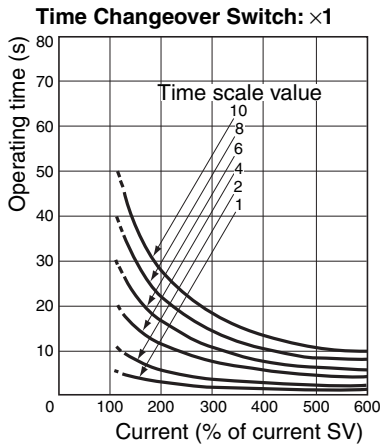

Open-phase Operating Characteristics

Open-phase Operating Time Characteristics

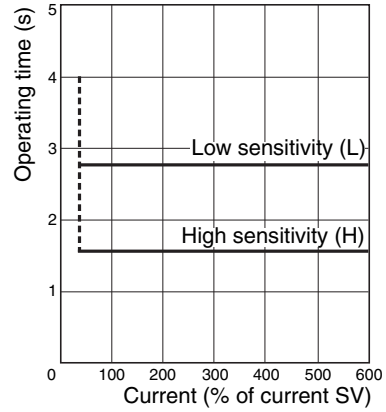
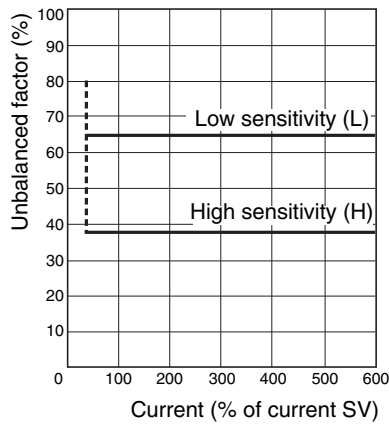

Operation

Settings

Motor Relay Switch Settings

LED Indicators

The LEDs indicate which function is in operation. OPEN refers to open-phase, OC refers to overcurrent, and RVS refers to reverse-phase.

Manual Reset

The reset button will pop out about 4 mm when the relay has been tripped. After the relay has operated, reset by pressing this button. Disconnect the power supply before resetting for reverse-phase operation.

Function Setting DIP SW

The three ON/OFF switches enable or disable the three functions. The functions can be enabled in any combination. With the open-phase function, the H/L switch sets the current unbalance factor. When set to H", the motor circuit operates at 35% of the current unbalance factor for operation. When set to L", the motor circuit operates at 65% min. of the current unbalance factor for operation. With the over-current function, the x4/x1 switch sets the time changeover value for the start-up mode. When set to x4", the operating time range is 4 to 40 s. When set to x1", the operating time range is 1 to 10 s.

Current Scale Multiplying Factor Decal

Determine the current scale multiplying factor corresponding to the current SV range obtained from Table 1 and paste the current scale multiplying decal to the motor protective relay. For example, when the current setting range is 8 to 20 A, the decal no. is 2.

Setting Operating Current

Set the current-setting knob to the required current value. The setting value is indicated by the product of the scale value and the multiplying factor as shown in the following table. The required trip current can be obtained directly by means of the current knob.

Decal No.	Current scale value (A)						
	4	5	6	7	8	9	10
0.25	1	1.25	1.5	1.75	2	2.25	2.5
0.5	2	2.5	3	3.5	4	4.5	5
1	4	5	6	7	8	9	10
2	8	10	12	14	16	18	20
4	16	20	24	28	32	36	40
8	32	40	48	56	64	72	80
16	64	80	96	112	128	144	160

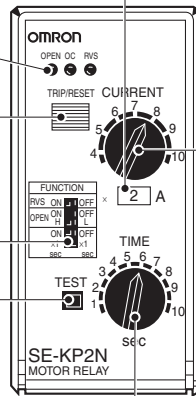

Setting Operating Time

Set the time setting knob to the required time. The operating time is equal to the time scale value times the setting on the time changeover switch. For example, if the time scale value is 6 and the time changeover switch is set to 4, the operating time is 24 s.

Test Button

Pushing the test button momentarily operates the trip display and the output relay. The operation indicators will not light for the test button. It doesn't matter whether the function setting switch is ON or OFF.

Current Converter Settings

Determining the Number of Primary Conductor Runs

Determine the number of passes and the tap setting from the table above. For example, if the current setting range is 8 to 20 A, there is one pass and the tap setting is 20. Pass the wires through the holes from the same direction. It doesn't matter which wires go through which holes.

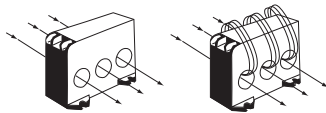

One conductor pass
(The conductors pass through the holes once.)

Four conductor passes
(The conductors pass through the holes four times.)

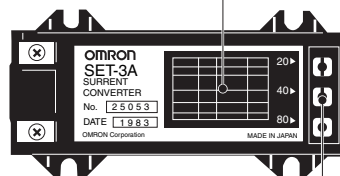

Tap Setting

In tap setting, insert the setting screw into the required tap hole with a screwdriver. After setting, be sure to replace the cover.

Selecting the Current Converter

The current requirements of the motor determine the current range of the Motor Protective Relay, and whether the SET-3A or SET-3B Current Converter should be used, as shown in the following table.

Motor specifications			Motor Protective Relay		Current Converter		
kW	HP	A	Current range	Decal No.	Passes	Tap settings	Model
0.2	0.25	1.4	1 to 2.5	0.25	8	20	SET-3A
0.4	0.5	2.3	2 to 5	0.5	4	20	
0.75	1	3.8					
Note 1		5					
1.5	2	6.8	4 to 10	1	2	20	
2.2	3	9.5	8 to 20	2	1	20	
3.7	5	15	16 to 40	4		40	
5.5	7.5	22				80	
7.5	10	30					
11	15	43	32 to 80	8		Fixed	
15	20	57	64 to 160	16			
19	25	72					
22	30	82					
30	40	111					
37	50	135					

Note: 1. Connect to the secondary of a commercial current transformer for motors exceeding 37 kW.

2. Connect a commercial current transformer when using high-voltage motors or low-voltage high-capacity motors.

Installation

Internal Circuit

Inverse Type

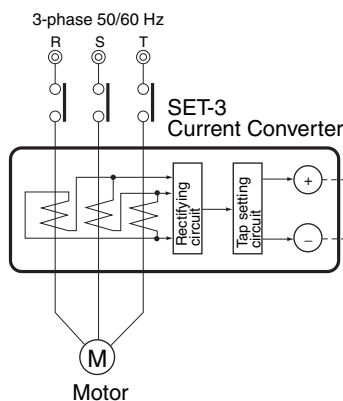

SE Motor Protective Relay

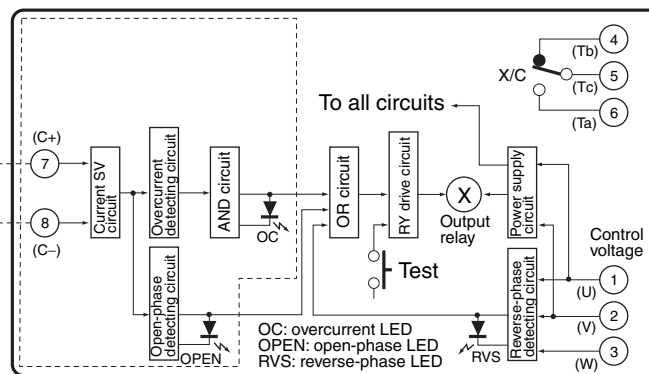

Instantaneous Type (Start-up Lock)

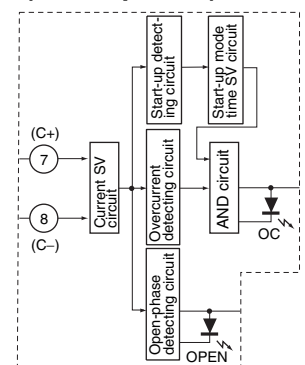

Note: 1. The numbers in circles are the terminal numbers for Plug-in Models. The letters in parentheses are the terminal markings on Panel-mounting Models.

2. You cannot use reverse-phase protection if you use control power with single-phase operation. Connect to terminals 1 and 2 for single-phase operation. Also, make sure to turn OFF the reverse-phase setting on the function setting switches. An error will occur if the SE is used with the reverse-phase setting turned ON during single-phase operation. Reverse-phase is detected in order of phase1, phase2 and phase3 of control power.

3. The AND circuit in the internal circuits contains a time setting circuit.

Connections

External Connections

Manual Operation Low-voltage Circuit

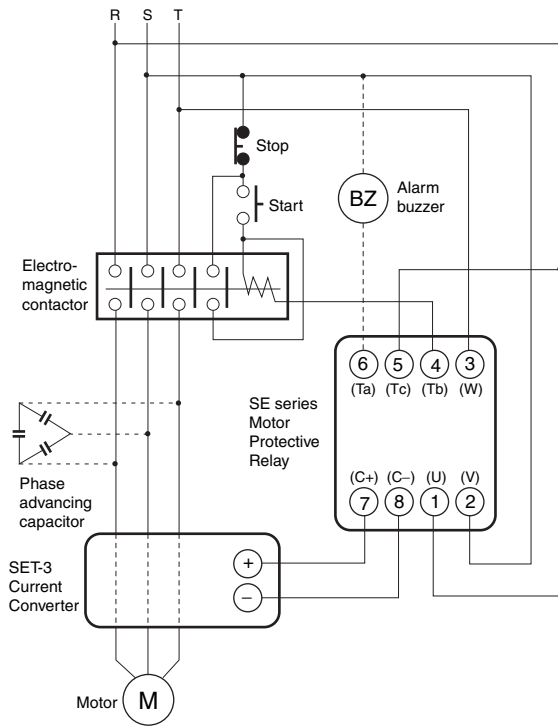

Automatic Operation Low-voltage Circuit

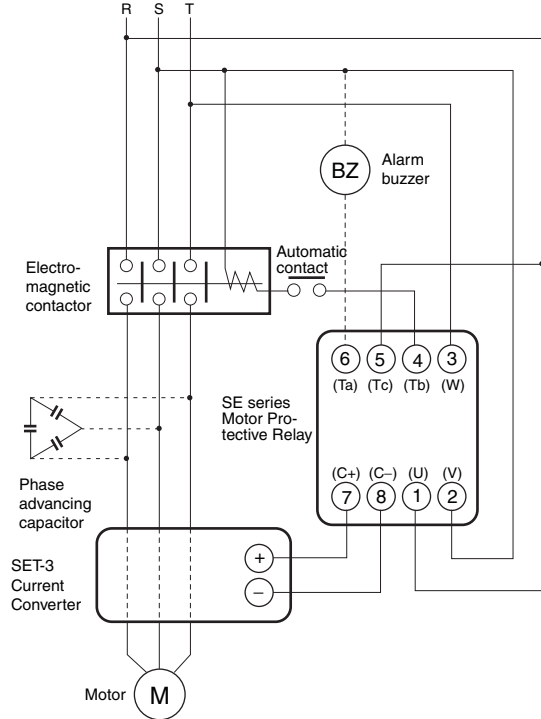

Manual Operation Low-voltage Circuit (λ-Δ Start)

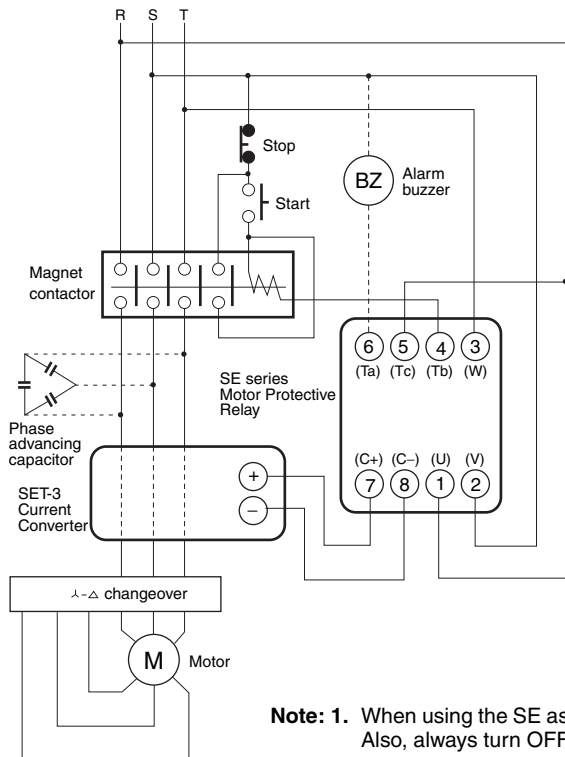

High-tension Motor No-voltage Tripping Circuit

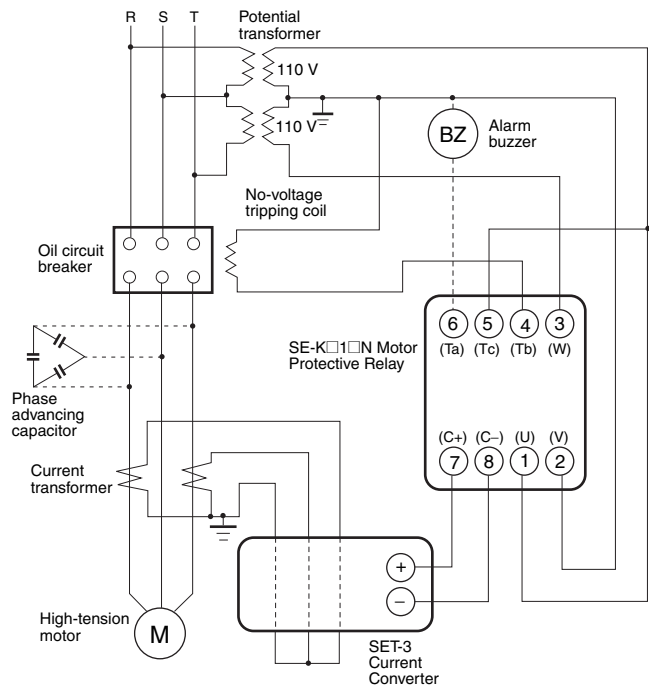

- Note:**
1. When using the SE as a 2E (overload and open-phase) relay, it is not necessary to connect terminal 3 (W). Also, always turn OFF the reverse-phase elements.
 2. When using a model with an automatic reset, the Motor Protective Relay may not operate if there is an open phase on the power supply side of the motor circuit.
 3. Supply control power to the Motor Protective Relay from the power supply side of the contactor. The Motor Protective Relay may not operate at the set time if the power supply of the Motor Protective Relay is turned ON at the same time that the motor starts.

**Manual Operation Low-voltage Circuit
(When using a SE-K□P2□N in a 400/440 VAC Circuit)**

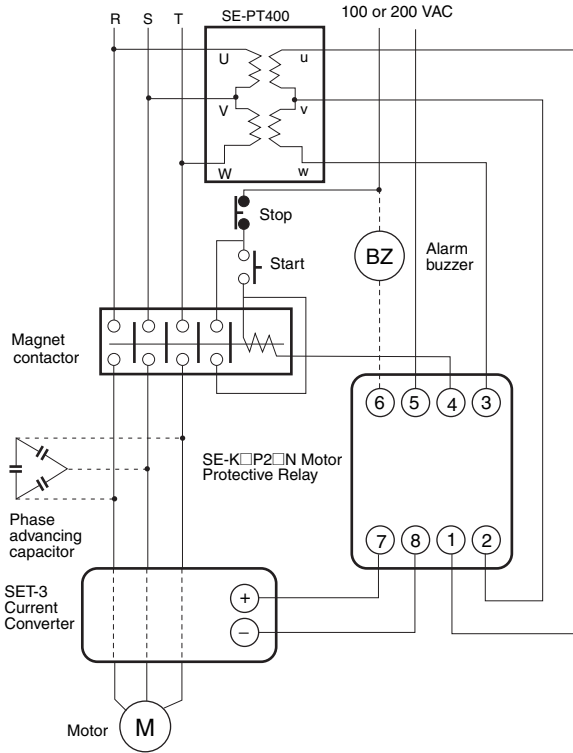

**Automatic Operation Low-voltage Circuit
(High-capacity Motor)**

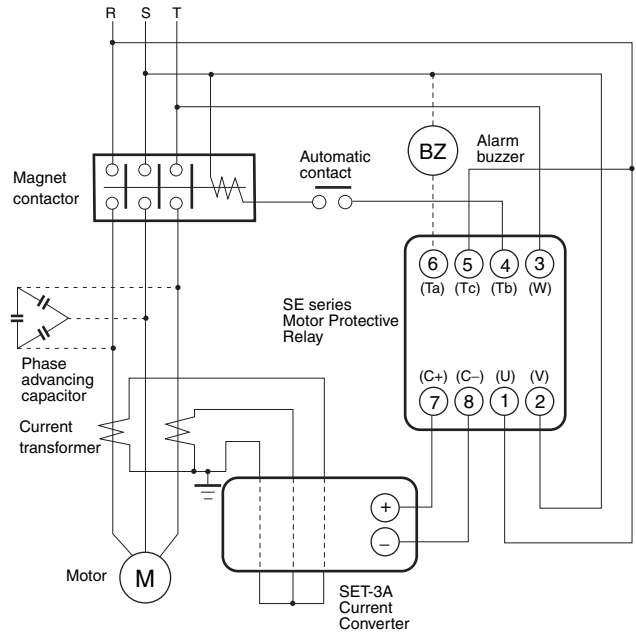

**Manual Operation Low-voltage Circuit
(Using the Overcurrent and Open-phase Functions)**

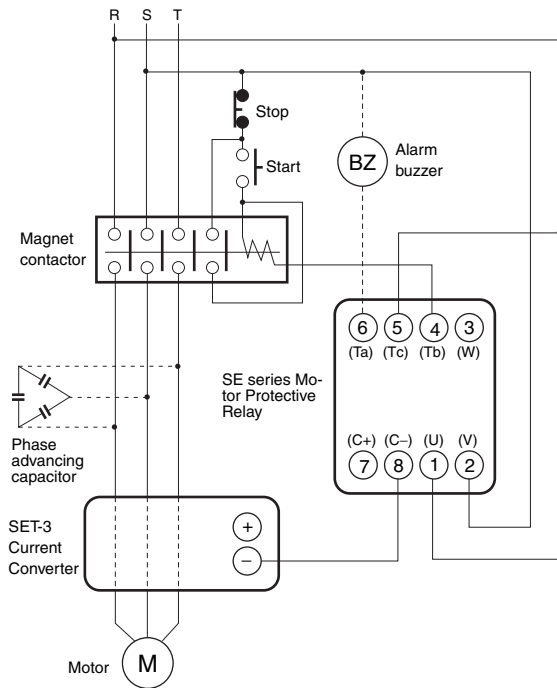

Automatic Operation

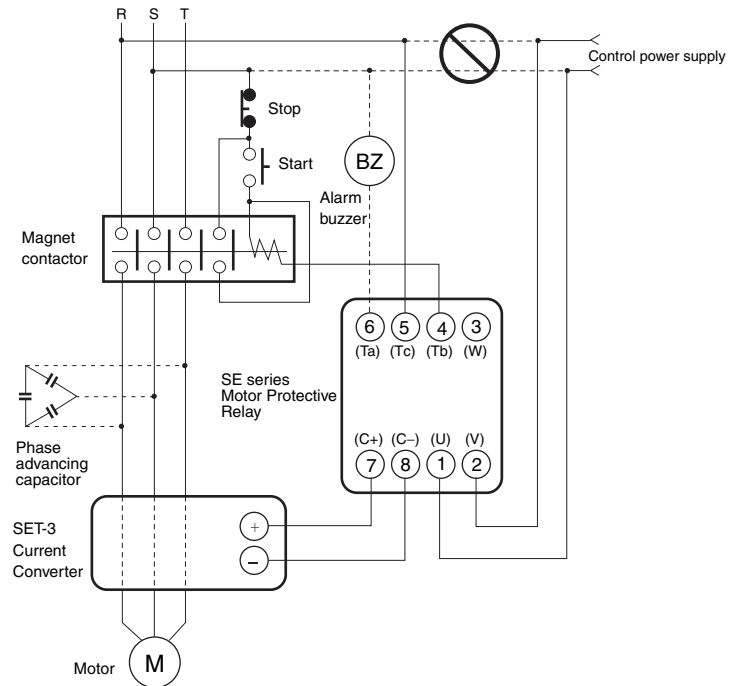

- Note:**
1. When using the SE as a 2E (overload and open-phase) relay, it is not necessary to connect terminal 3 (W). Also, always turn OFF the reverse-phase elements.
 2. When using a model with an automatic reset, the Motor Protective Relay may not operate if there is open phase on the power supply side of the motor circuit.
 3. Supply control power to the Motor Protective Relay from the power supply side of the contactor. The Motor Protective Relay may not operate at the set time if the power supply of the Motor Protective Relay is turned ON at the same time that the motor starts.

Dimensions

Note: All units are in millimeters unless otherwise indicated.

Plug-in Socket Terminal SE-KP□N, SE-KQP□N

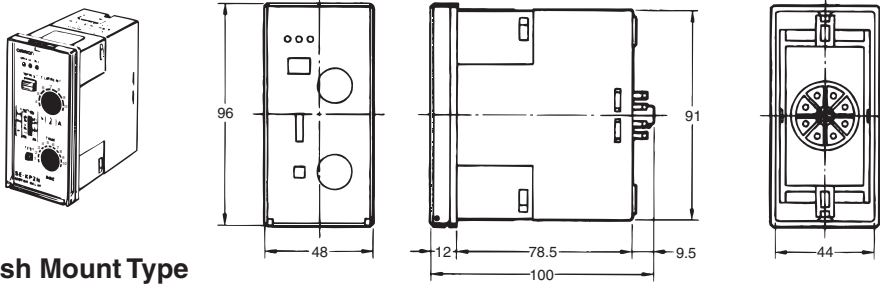

The Height of DIN Rail Mounting

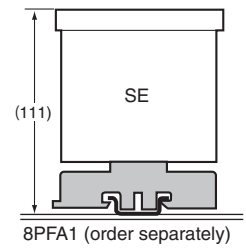

Flush Mount Type SE-K□N, SE-KQ□N

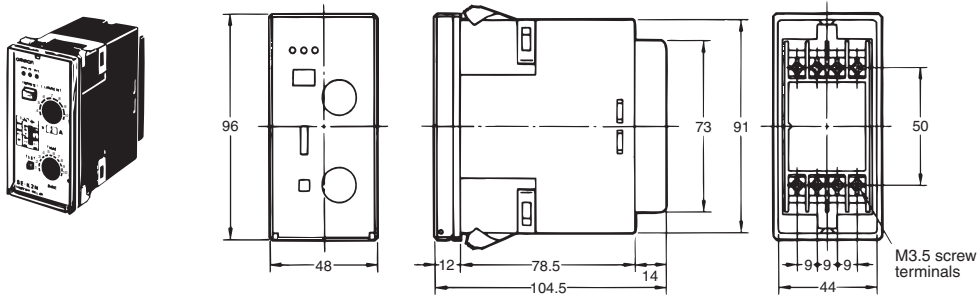

Panel Cutout

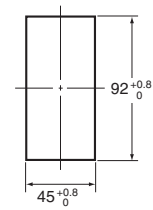

Current Converter SET-3A, SET-3B

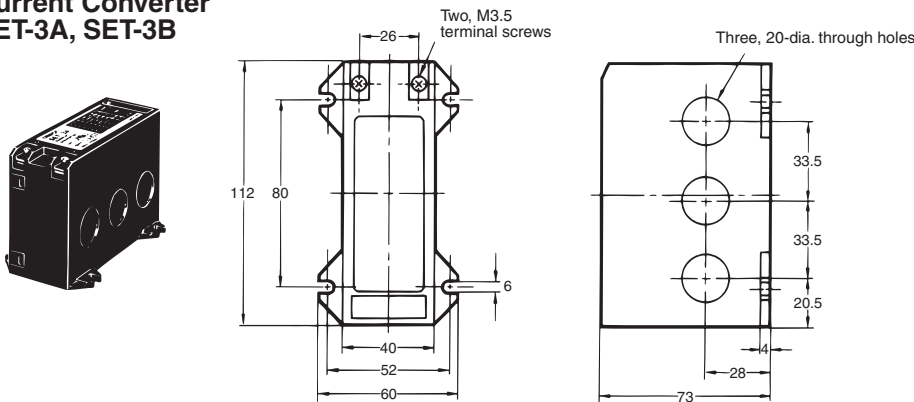

Mounting Holes

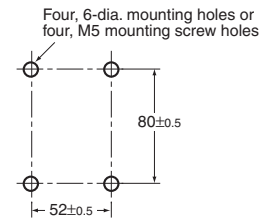

Transformer SE-PT400 (for Use with the SE-K(Q)P2EN)

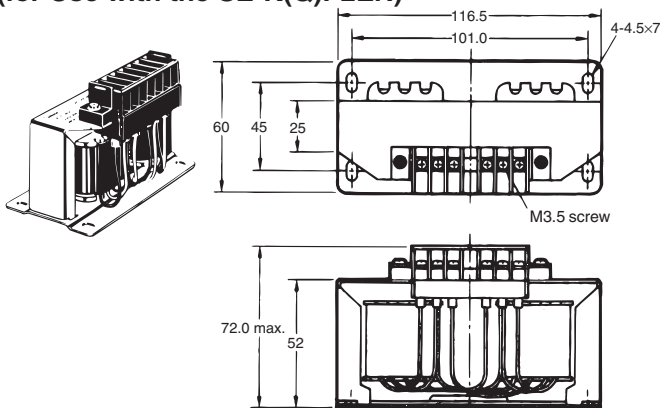

Optional Adapter SE-F7AD

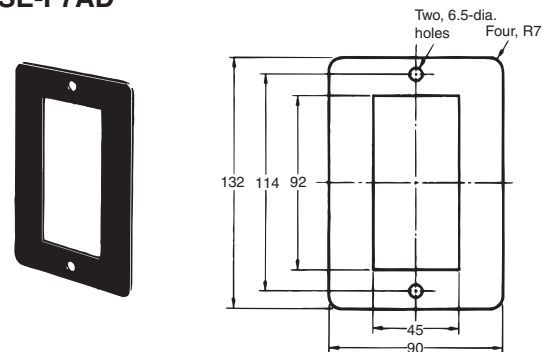

Note: The SE-PT400 can be used for all 200/220/240-VAC SE Relays. Primary voltage: 380 to 480 VAC Secondary voltage: 190 to 240 VAC

Note: This Adapter is used to replace existing flush mount models with new models. Plate material: Steel plate (thickness: 2.0 mm) Color: Black (Munsell N1.5)

■ Testing Method

With the circuit shown below, the characteristics listed in the following table can be tested. Determine the number of conductor runs through the holes of the current transformer in accordance with the operating current range of the Motor Protective Relay and by referring to the table in the section *Selecting the Current Converter*.



3φSD: 3-phase voltage regulator (5 to 15 A)

A: AC ammeter

V: AC voltmeter (300 V)

CC: cycle counter

Y: auxiliary relay (15 A)

R₁: variable resistor (50 Ω, 400 W + 400 W)

R₂: fixed resistor (50 Ω, 400 W + 400 W)

SW₁: knife switch (three-phase)

SW₂: toggle switch

Test item	Test procedure	
	Operating value	Operating time
Overcurrent	<ol style="list-style-type: none"> 1. Turn on SW₁. 2. Turn on SW₂ to operate auxiliary relay Y. 3. Gradually increase the current by adjusting the voltage regulator. Read the positions at which the relay operates. 4. Turn off SW₁. 	<ol style="list-style-type: none"> 1. Turn on SW₁ and SW₂ and increase the current to the Current Converter to 600% of the current SV by adjusting the voltage regulator. Then turn off SW₁ and SW₂. 2. Turn on SW₁. 3. Turn on SW₂ and record the value of the cycle counter CC when it is stopped by the relay operation. 4. Turn off SW₂.
Open-phase	<ol style="list-style-type: none"> 1. Open (burn-out) any one of the Current Converter input phases. 2. Turn on SW₁ and SW₂. Gradually increase the current by adjusting the voltage regulator. 3. Confirm that the relay operates when the current is 50% or less of the current SV. 4. Turn off SW₁. 	<ol style="list-style-type: none"> 1. Open (burn-out) any one of the Current Converter input phases. Adjust the voltage regulator so that the currents of the other two phases equal the current SV. 2. Turn on SW₁ and SW₂, and record the value of the cycle counter CC when it stops. 3. Turn off SW₂.
Reverse-phase	<ol style="list-style-type: none"> 1. Reverse the leads at terminals 2 and 3 of the relay (indicated by the dashed lines) to create a reverse-phase condition. 2. Turn on SW₁ and SW₂ and confirm that the relay operates. 3. Connect the voltage regulator to terminals 1, 2, and 3. 4. Increase the voltage by adjusting the voltage regulator, and confirm that the relay operates when the voltage is below 80% or less of the rated voltage. 	<ol style="list-style-type: none"> 1. Create a reverse-phase condition at the voltage inputs. 2. Turn on SW₁ and SW₂, and record the value of the cycle counter CC when it stops. 3. Turn off SW₂.

■ Checking Operation

Checklist After Connection and Before Starting Motor

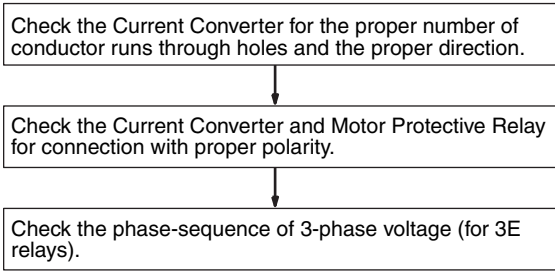

Test Operation

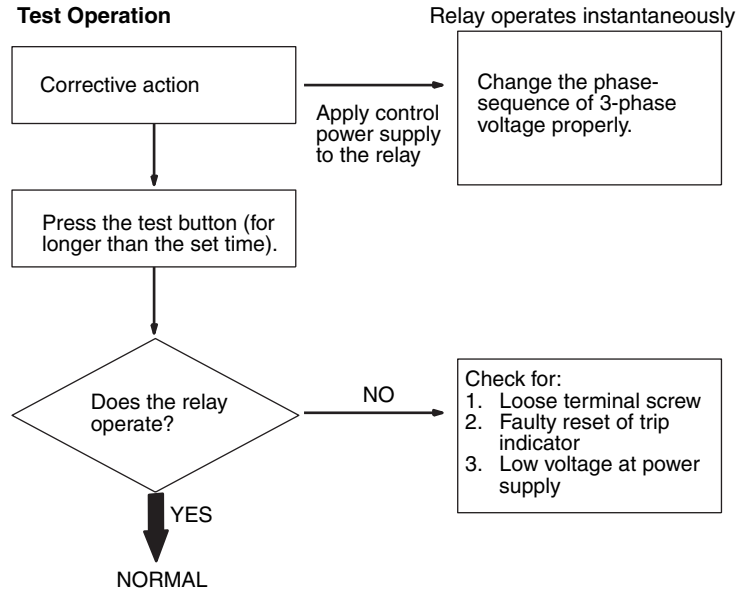

Troubleshooting

Trouble	Check Points
Relay operates before the motor starting time has elapsed. (OPEN indicator)	<ol style="list-style-type: none"> 1. Is there any open-phase trouble in the motor or its circuit (fuses, electromagnetic contactors, wiring)? 2. Does the Current Converter have the correct number of conductor runs through holes? Does the conductor run in the proper direction? 3. Is the supply voltage or motor current unbalanced (unbalanced factor of more than 35%)?
Relay operates after the motor starting time has elapsed. (OC indicator)	<ol style="list-style-type: none"> 1. Does the set current match the motor current? 2. Does the set operating time match the motor starting time? 3. Does the Current Converter have the correct number of conductor runs through the holes?
Motor circuit is not tripped when the relay operates following the depression of the test button.	<ol style="list-style-type: none"> 1. Disconnect terminals 4, 5, and 6, (Ta, Tb and Tc with the flush mount type) and check the relay contacts for electrical continuity.
Relay doesn't operate properly under light loads.	<ol style="list-style-type: none"> 1. Check each phase for an unbalance of more than 35%, and also check for waveform distortion. 2. If the open-phase unbalance sensitivity switch is set to "H", then switch it to "L". 3. If the switch is already set to "L", then the open-phase ON/OFF switch can be set to OFF, but the open-phase function will be disabled.

■ Calculating the Unbalanced Factor

The unbalanced factor can be obtained easily from the following graph. In the graph, the horizontal axis indicates the phase of the maximum current, whereas the two vertical axes indicate the remaining two phases. Taking the phase of the maximum current with a reference value of 1.0, the unbalanced factor is obtained in percentage from the curves centered in the graph.

When the motor current $I_R = 100$ A, $I_S = 60$ A, and $I_T = 70$ A, calculate the ratios of the currents, setting the value of the maximum current to 1. In this case the ratios are 1 : 0.6 : 0.7 ($I_R : I_S : I_T$).

To find the unbalanced factor, follow the arcs from the ratio values on the vertical axes, in this case 0.6 and 0.7, to their intersection point. The unbalanced factor can be estimated from the values on the graph. Here the unbalanced factor is approx. 36%.

Questions and Answers

Q When using the SE as a 2E (overload and open-phase) relay, can the control power supply voltage be supplied separately from the motor circuit?

A Yes. Operation will be correct.

Q What is the input volt-amp consumption of the SET-3□?

A Input Volt-Amp Consumption of SET-3□ at Rated Current

SET-3A	At 20 A for 20-A model	Approx. 0.1 VA/phase
	At 40 A for 40-A model	Approx. 0.2 VA/phase
	At 80 A for 80-A model	Approx. 0.4 VA/phase
SET-3B	At 160 A	Approx. 0.4 VA/phase

Q Why is the control power supply 100/110 V?

A The main reason the SE uses a 100/110-V control power supply is because 100/110 V is applicable to high-voltage motor protection. With a high-voltage motor, the voltage is first reduced with a potential transformer, and the secondary side is connected to the SE. When using the SE as a 2E (overload and open-phase) relay, a normal 100-V power supply can be used without connecting to the secondary side of a potential transformer.

Q How long of a power interruption is required to restart the startup lock timer with an Instantaneous-type SE Relay (with startup lock)?

A Approx. 0.5 s min.

Q Why is it not possible to use the SE in a circuit containing thyristor control or a rectifier?

A A schematic diagram showing the operating principle for the SE is shown below.

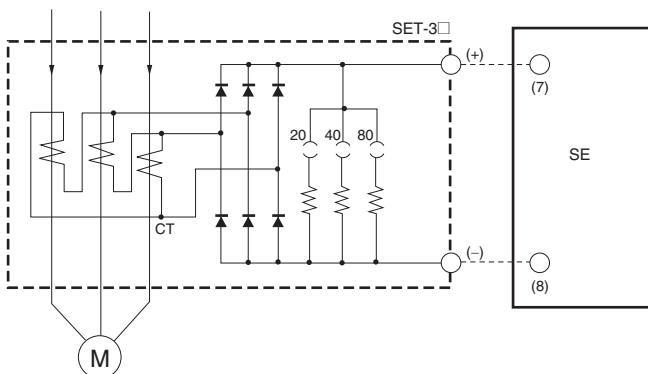

As shown in the above diagram, the waves for all three phases of the motor current from the CT of the SET-3□ are rectified, then converted to DC voltage, which is necessary for the SE, by the resistor at each tap, and output from the positive and negative terminals. The DC and AC component ratios in this voltage differ between the normal three-phase condition and conditions of phase-failure or unbalance.

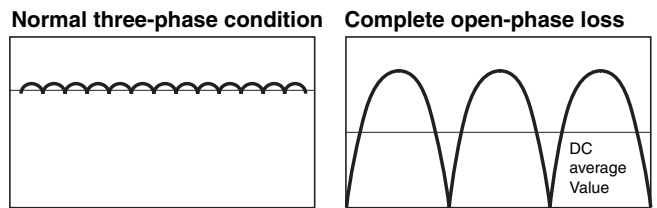

For the overload factor, the DC average level is detected relative to the set value. For the phase-failure factor, the proportion of the DC average level and AC component is used to distinguish phase failure or unbalance.

When the motor is operated using thyristor phase control, the motor current waveform is not a sine wave. The SE detects this as an adverse condition and initiates unnecessary operations. The example below shows a primary current and SET-3□ output waveform. When there is a large AC component in the output voltage, the SE series sometimes judges it to be a phase-failure and initiates unnecessary operations.

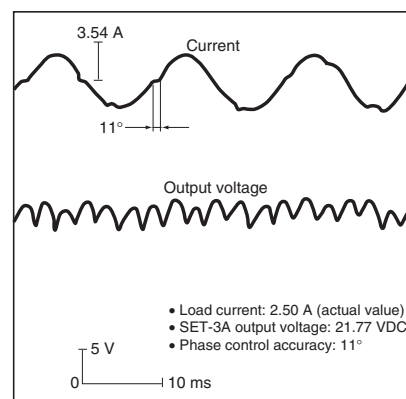
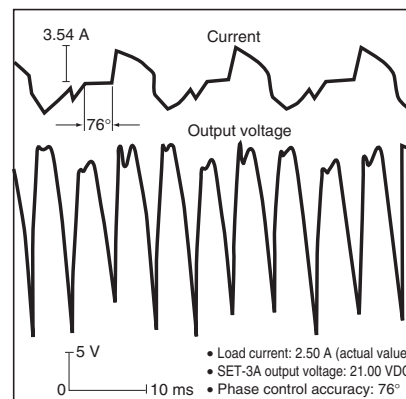

Q What is the range of the operating time for inverse operation?

A Use the values in the following table as guidelines.

Time scale: × 1 (s) Time scale: × 4 (s)

Operating time setting	Percentage of current setting	
	200%	600%
1	1.0 to 7.3	0.5 to 2.0
2	1.9 to 10.9	1.0 to 3.0
3	3.9 to 14.6	2.0 to 4.0
4	5.9 to 18.2	3.0 to 5.0
5	7.8 to 21.9	4.0 to 6.0
6	9.8 to 25.5	5.0 to 7.0
7	11.7 to 29.1	6.0 to 8.0
8	13.7 to 32.8	7.0 to 9.0
9	15.7 to 36.4	8.0 to 10.0
10	17.6 to 40.0	9.0 to 11.0

Operating time setting	Percentage of current setting	
	200%	600%
1	3.9 to 29.1	2.0 to 8.0
2	7.8 to 43.7	4.0 to 12.0
3	15.7 to 58.3	8.0 to 16.0
4	23.5 to 72.8	12.0 to 20.0
5	31.3 to 87.4	16.0 to 24.0
6	39.2 to 102	20.0 to 28.0
7	47.0 to 117	24.0 to 32.0
8	54.9 to 131	28.0 to 36.0
9	62.7 to 146	32.0 to 40.0
10	70.5 to 160	36.0 to 44.0

Q What is the approximate DC output voltage of an SET-3□ Current Converter?

A Use the voltages in the following chart as a guide.

Output voltage	Percentage of SET-3□ current setting tap value				
	40	100	200	400	600
DC output voltage (VDC)	8.4	21	42	84	123

Note: 1. This is the output voltage when connected to an SE Motor Protective Relay or SAO Current Sensor. When connected to any other model, the output voltages will be about the same as those shown in the above table when the input impedance is 13.3 kΩ.
2. When testing an SE or SAO with the output voltages shown in the above table, consider the voltage values to be a guideline only.

SET-3A/3B Current Converter Three-phase Input Current and Output Voltage Characteristics

Reference

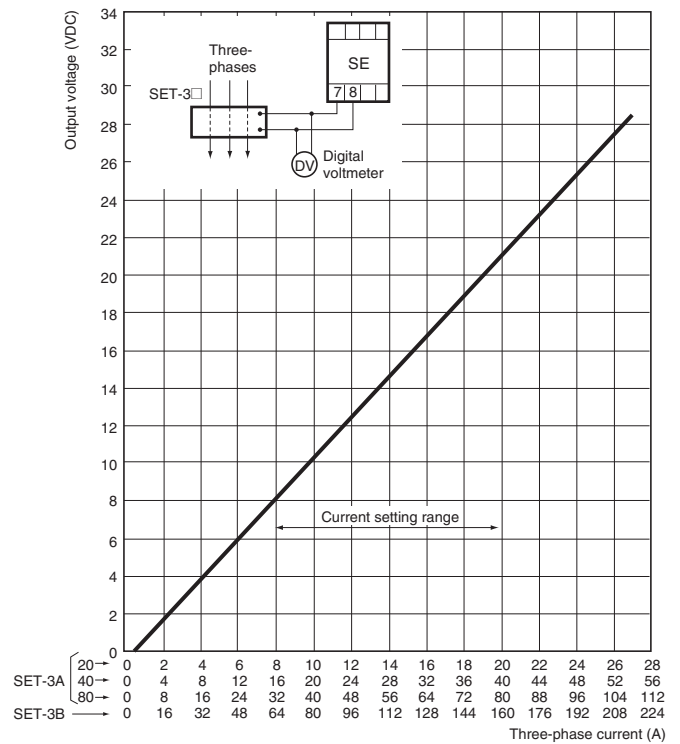

Q Can the SE be used for single-phase applications?

A Yes it can, but the open-phase element cannot be used. Turn OFF the open-phase setting on the function setting DIP switch. Refer to the Q&A section on the SAO Current Sensor for the overcurrent setting method. Consider using an SAO-□S Current Sensor (for single-phase).

Q What will happen if a control power supply with an automatic reset is taken from the same circuit as the motor circuit?

A The allowable fluctuation range for a control power supply with an automatic reset is 85% to 110%. An open phase in the motor circuit power supply will reduce the voltage to up to 50%. Thus, a power supply with an automatic reset will not be able to operate.

Q Can the SE be used for three signal-phase lines?

A The SE is designed for three-phase power. It cannot be used for three single-phase lines. Consider using an SAO-□S Current Sensor (for single-phase).

Q Can the SE be used in an inverter circuit?

A The SE may not work properly in an inverter circuit.

- The error in the overload element will increase and the open-phase element will operate unnecessarily.
- The SE does not contain circuits to remove inverter noise.

Q Can two SE Relays be connected to the SET-3□?

A No, they cannot. Refer to the Q&A section on the SAO Current Sensor.

Safety Precautions

On Operation

Connect the phase advancing capacitor to the power supply before the Current Converter.

There are cases in which a 100/110 V power supply can be used. The main reason for using a 100/110 V power supply is to protect a high-tension motor. With a high-voltage power supply, the voltage must be reduced with a potential transformer. It is also possible to use a 100/110 V power supply with the 2E-type (two function) relays.

Use a commercial frequency power supply only for the control power supply.

The Motor Protective Relay cannot be connected to circuits containing thyristors, rectifiers, or VVVF inverters. See explanation under the heading *Use with Thyristors, Rectifiers, or VVVF Inverters*, below.

The Motor Protective Relay also cannot be used to detect an overcurrent in an inching run, because the overcurrent detection circuit is reset at every inching step.

When using an SE relay with a current requirement below 1 A, increase the number of conductor runs through the holes in the Current Converter.

Use a model SAO sensor for single-phase applications. Refer to the SAO datasheet.

Mounting

When installing with an 8PFA1 connecting socket, first fasten the socket firmly to the panel with screws, then plug in the relay and secure it with a hook. Leave at least 30 mm of space between the relays for the hooks.

Although there is no particular restriction on the mounting direction, it is best to mount horizontally.

The recommended panel thickness for panel mounting is 1 to 3.2 mm.

Connections

Make sure that the polarity is correct when connecting the Current Converter and relay.

When using a commercial current transformer with a high-tension or low-voltage, high-capacity motor, pass the external wiring of the secondary through the holes in the Current Converter.

When using as a 3E (3 function) relay, connect the three-phase voltage correctly, as with external connections.

When using as a 2E (2 function) relay, it is not necessary to connect terminal 3 (W).

ALL DIMENSIONS SHOWN ARE IN MILLIMETERS.

To convert millimeters into inches, multiply by 0.03937. To convert grams into ounces, multiply by 0.03527.

In the interest of product improvement, specifications are subject to change without notice.

Terms and Conditions Agreement

Read and understand this catalog.

Please read and understand this catalog before purchasing the products. Please consult your OMRON representative if you have any questions or comments.

Warranties.

(a) Exclusive Warranty. Omron's exclusive warranty is that the Products will be free from defects in materials and workmanship for a period of twelve months from the date of sale by Omron (or such other period expressed in writing by Omron). Omron disclaims all other warranties, express or implied.

(b) Limitations. OMRON MAKES NO WARRANTY OR REPRESENTATION, EXPRESS OR IMPLIED, ABOUT NON-INFRINGEMENT, MERCHANTABILITY OR FITNESS FOR A PARTICULAR PURPOSE OF THE PRODUCTS. BUYER ACKNOWLEDGES THAT IT ALONE HAS DETERMINED THAT THE PRODUCTS WILL SUITABLY MEET THE REQUIREMENTS OF THEIR INTENDED USE.

Omron further disclaims all warranties and responsibility of any type for claims or expenses based on infringement by the Products or otherwise of any intellectual property right. (c) Buyer Remedy. Omron's sole obligation hereunder shall be, at Omron's election, to (i) replace (in the form originally shipped with Buyer responsible for labor charges for removal or replacement thereof) the non-complying Product, (ii) repair the non-complying Product, or (iii) repay or credit Buyer an amount equal to the purchase price of the non-complying Product; provided that in no event shall Omron be responsible for warranty, repair, indemnity or any other claims or expenses regarding the Products unless Omron's analysis confirms that the Products were properly handled, stored, installed and maintained and not subject to contamination, abuse, misuse or inappropriate modification. Return of any Products by Buyer must be approved in writing by Omron before shipment. Omron Companies shall not be liable for the suitability or unsuitability or the results from the use of Products in combination with any electrical or electronic components, circuits, system assemblies or any other materials or substances or environments. Any advice, recommendations or information given orally or in writing, are not to be construed as an amendment or addition to the above warranty.

See <http://www.omron.com/global/> or contact your Omron representative for published information.

Limitation on Liability; Etc.

OMRON COMPANIES SHALL NOT BE LIABLE FOR SPECIAL, INDIRECT, INCIDENTAL, OR CONSEQUENTIAL DAMAGES, LOSS OF PROFITS OR PRODUCTION OR COMMERCIAL LOSS IN ANY WAY CONNECTED WITH THE PRODUCTS, WHETHER SUCH CLAIM IS BASED IN CONTRACT, WARRANTY, NEGLIGENCE OR STRICT LIABILITY.

Further, in no event shall liability of Omron Companies exceed the individual price of the Product on which liability is asserted.

Suitability of Use.

Omron Companies shall not be responsible for conformity with any standards, codes or regulations which apply to the combination of the Product in the Buyer's application or use of the Product. At Buyer's request, Omron will provide applicable third party certification documents identifying ratings and limitations of use which apply to the Product. This information by itself is not sufficient for a complete determination of the suitability of the Product in combination with the end product, machine, system, or other application or use. Buyer shall be solely responsible for determining appropriateness of the particular Product with respect to Buyer's application, product or system. Buyer shall take application responsibility in all cases.

NEVER USE THE PRODUCT FOR AN APPLICATION INVOLVING SERIOUS RISK TO LIFE OR PROPERTY OR IN LARGE QUANTITIES WITHOUT ENSURING THAT THE SYSTEM AS A WHOLE HAS BEEN DESIGNED TO ADDRESS THE RISKS, AND THAT THE OMRON PRODUCT(S) IS PROPERLY RATED AND INSTALLED FOR THE INTENDED USE WITHIN THE OVERALL EQUIPMENT OR SYSTEM.

Programmable Products.

Omron Companies shall not be responsible for the user's programming of a programmable Product, or any consequence thereof.

Performance Data.

Data presented in Omron Company websites, catalogs and other materials is provided as a guide for the user in determining suitability and does not constitute a warranty. It may represent the result of Omron's test conditions, and the user must correlate it to actual application requirements. Actual performance is subject to the Omron's Warranty and Limitations of Liability.

Change in Specifications.

Product specifications and accessories may be changed at any time based on improvements and other reasons. It is our practice to change part numbers when published ratings or features are changed, or when significant construction changes are made. However, some specifications of the Product may be changed without any notice. When in doubt, special part numbers may be assigned to fix or establish key specifications for your application. Please consult with your Omron's representative at any time to confirm actual specifications of purchased Product.

Errors and Omissions.

Information presented by Omron Companies has been checked and is believed to be accurate; however, no responsibility is assumed for clerical, typographical or proofreading errors or omissions.

2016.4

In the interest of product improvement, specifications are subject to change without notice.

OMRON Corporation
Industrial Automation Company

<http://www.ia.omron.com/>

(c)Copyright OMRON Corporation 2016 All Right Reserved.

Mouser Electronics

Authorized Distributor

Click to View Pricing, Inventory, Delivery & Lifecycle Information:

Omron:

[SE-K1EN](#) [SE-K2EN](#) [SE-K2N](#) [SE-K4EN](#) [SE-KP1AN](#) [SE-KP1EN](#) [SE-KP1N](#) [SE-KP2EN](#) [SE-KQ2EN](#) [SE-KQP1EN](#)
[SE-KQP1N](#) [SE-KQP2EN](#) [SE-KQP2N](#)

Компания «Океан Электроники» предлагает заключение долгосрочных отношений при поставках импортных электронных компонентов на взаимовыгодных условиях!

Наши преимущества:

- Поставка оригинальных импортных электронных компонентов напрямую с производств Америки, Европы и Азии, а так же с крупнейших складов мира;
- Широкая линейка поставок активных и пассивных импортных электронных компонентов (более 30 млн. наименований);
- Поставка сложных, дефицитных, либо снятых с производства позиций;
- Оперативные сроки поставки под заказ (от 5 рабочих дней);
- Экспресс доставка в любую точку России;
- Помощь Конструкторского Отдела и консультации квалифицированных инженеров;
- Техническая поддержка проекта, помощь в подборе аналогов, поставка прототипов;
- Поставка электронных компонентов под контролем ВП;
- Система менеджмента качества сертифицирована по Международному стандарту ISO 9001;
- При необходимости вся продукция военного и аэрокосмического назначения проходит испытания и сертификацию в лаборатории (по согласованию с заказчиком);
- Поставка специализированных компонентов военного и аэрокосмического уровня качества (Xilinx, Altera, Analog Devices, Intersil, Interpoint, Microsemi, Actel, Aeroflex, Peregrine, VPT, Syfer, Eurofarad, Texas Instruments, MS Kennedy, Miteq, Cobham, E2V, MA-COM, Hittite, Mini-Circuits, General Dynamics и др.);

Компания «Океан Электроники» является официальным дистрибьютором и эксклюзивным представителем в России одного из крупнейших производителей разъемов военного и аэрокосмического назначения «JONHON», а так же официальным дистрибьютором и эксклюзивным представителем в России производителя высокотехнологичных и надежных решений для передачи СВЧ сигналов «FORSTAR».



JONHON

«JONHON» (основан в 1970 г.)

Разъемы специального, военного и аэрокосмического назначения:

(Применяются в военной, авиационной, аэрокосмической, морской, железнодорожной, горно- и нефтедобывающей отраслях промышленности)

«FORSTAR» (основан в 1998 г.)

ВЧ соединители, коаксиальные кабели, кабельные сборки и микроволновые компоненты:

(Применяются в телекоммуникациях гражданского и специального назначения, в средствах связи, РЛС, а так же военной, авиационной и аэрокосмической отраслях промышленности).



Телефон: 8 (812) 309-75-97 (многоканальный)

Факс: 8 (812) 320-03-32

Электронная почта: ocean@oceanchips.ru

Web: <http://oceanchips.ru/>

Адрес: 198099, г. Санкт-Петербург, ул. Калинина, д. 2, корп. 4, лит. А