

## DESCRIPTION

Demonstration circuit 519 is a 1.1MHz dual step-down DC/DC switching converter using the LT1940. The LT1940 features fast switching speed, two 1.6A internal power switches, and a wide input voltage range, making it a versatile and powerful IC that fits easily into space-constrained applications and removes the need for two separate dc/dc converters in dual output step-down applications. The constant 1.1MHz switching frequency allows for the use of tiny, surface mount external components. The current-mode control topology yields fast transient response and good loop stability, requiring a minimum number of external compensation components and allowing the use of ceramic input and output capacitors. The anti-phase switching and single-IC solution require the use of only a single input capacitor. The low resistance internal 2A power switches ( $0.21\Omega$ ) maintain high efficiencies (as high as 90%) over a wide range of input voltages and loads. Its  $30\mu\text{A}$  shutdown current (activated via the Run/SS pins) extends battery life. The wide  $V_{\text{IN}}$  range of the LT1940 allows step-down configurations with up to 25V input.

The demonstration board has two circuits to demonstrate both the small space that the monolithic dual step-down converter can achieve with high currents and a single IC as well as the versatility and maximum power output of the IC. The circuit demonstrating

smallest size generates 3.3V at up to 1A and 1.8V at up to 1A output from a 4.8V–14V input. The larger, more versatile circuit generates 5V at up to 1.4A and 3.3V at up to 1.4A output from a separate 6.8V to 25V input. The two circuits are completely isolated from each other and can be run simultaneously or independently. The versatile circuit has options for changing the boost diodes for highest efficiency under different output voltage conditions. The feedforward capacitors and noise-reduction capacitors on the Vc pins further increase the parts count on the versatile board, yet they improve the transient response and give the ability to optimize loop compensation under various conditions.

This board is designed for applications that require two step-down supplies with up to 1.4A load current in a small board space with low cost and low parts count as well as simple circuit design. The high current, on-board, dual monolithic switches eliminate the need for external switches. The use of ceramic capacitors in this circuit not only demonstrates small size and low cost, but the advantage of current-mode control in step-down applications with a simple compensation network and a feedforward capacitor for more rugged stability and excellent transient response.

**Design files for this circuit board are available. Call the LTC factory.**

**Table 1. Typical Performance ( $T_A = 25^\circ\text{C}$ ) for Small Dual Step-Down Converter ( $V_{\text{OUT1}}=3.3\text{V}$  and  $V_{\text{OUT2}}=1.8\text{V}$ )**

PARAMETER	VALUE
$V_{\text{IN}}$	4.8V to 14V
$V_{\text{OUT1}}$	3.3V
$V_{\text{OUT2}}$	1.8V
$V_{\text{OUT1}}$ Load Current	1A(max)
$V_{\text{OUT2}}$ Load Current	1A(max)
Efficiency	80% at 1A load current ( $V_{\text{OUT1}}$ and $V_{\text{OUT2}}$ )

# QUICK START GUIDE FOR DEMONSTRATION CIRCUIT 519

## 1.1MHZ DUAL STEP-DOWN DC/DC CONVERTER

**Table 2. Typical Performance ( $T_A = 25^\circ\text{C}$ ) for Customizable Dual Step-Down Converter ( $V_{OUT1}=5.0\text{V}$  and  $V_{OUT2}=3.3\text{V}$ )**

Parameter	Value
$V_{IN}$	6.8V to 25V
$V_{OUT1}$	5.0V
$V_{OUT2}$	3.3V
$V_{OUT1}$ Load Current	1.4A(max)
$V_{OUT2}$ Load Current	1.4A(max)
Efficiency	84% at 1A load current ( $V_{OUT1}$ and $V_{OUT2}$ )

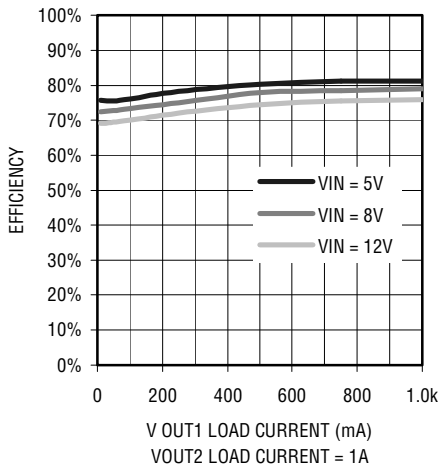

**Figure 1. Typical Efficiency of Demo Circuit 519 LT1940, Small Dual Step-Down  $V_{OUT1}=3.3\text{V}$ ,  $V_{OUT2}=1.8\text{V}$**

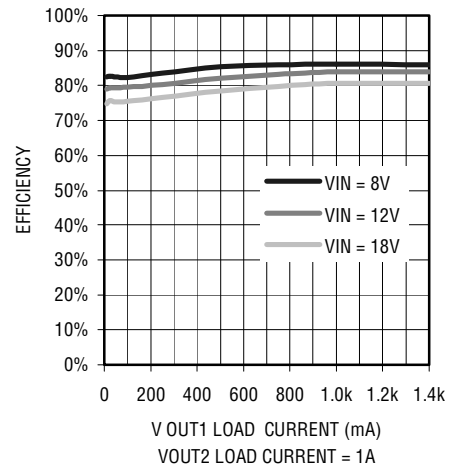

**Figure 3. Typical Efficiency of Demo Circuit 519 LT1940, Customizable Dual Step-Down  $V_{OUT1}=5.0\text{V}$ ,  $V_{OUT2}=3.3\text{V}$**

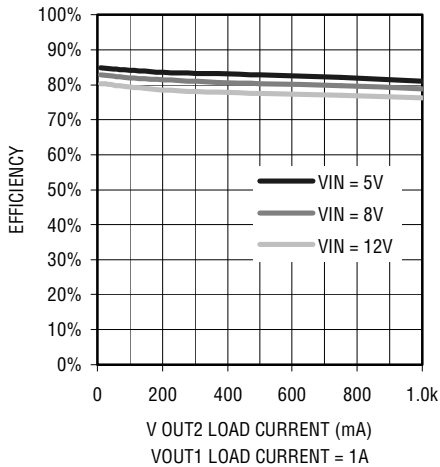

**Figure 2. Typical Efficiency of Demo Circuit 519 LT1940, Small Dual Step-Down  $V_{OUT1}=3.3\text{V}$ ,  $V_{OUT2}=1.8\text{V}$**

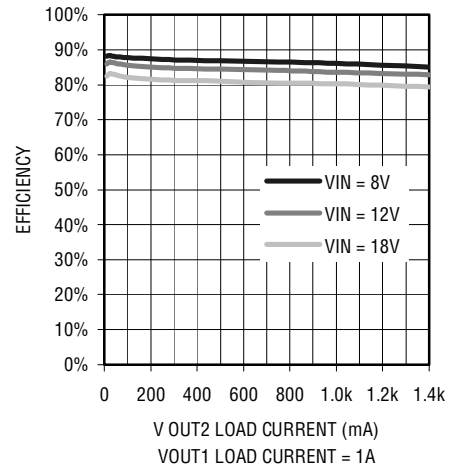

**Figure 4. Typical Efficiency of Demo Circuit 519 LT1940, Customizable Dual Step-Down  $V_{OUT1}=5.0\text{V}$ ,  $V_{OUT2}=3.3\text{V}$**

# QUICK START GUIDE FOR DEMONSTRATION CIRCUIT 519

## 1.1MHz DUAL STEP-DOWN DC/DC CONVERTER

### QUICK START PROCEDURE

Demonstration circuit 519 is easy to set up to evaluate the performance of the LT1940. Refer to Figure 5 for proper measurement equipment setup and follow the procedure below:

1. Connect the 4.8V–14V or 6.8V–25V input power supply to the VIN and GND terminals on the board corresponding to the small, top circuit or the larger, customizable, bottom circuit. Each circuit is powered separately from its own VIN and GND terminals.
2. After all connections are made, turn on input power and verify that the output voltage is either 3.3V and 1.8V (small, top circuit) or 5V and 3.3V (larger, bottom circuit) for the circuit to which the input supply is connected.
3. The Run/SS and Power Good functions are optional and their terminals can be left floating (disconnected) if their functions are not being used. Connecting a Run/SS terminal to the GND terminal will disable the corresponding output.

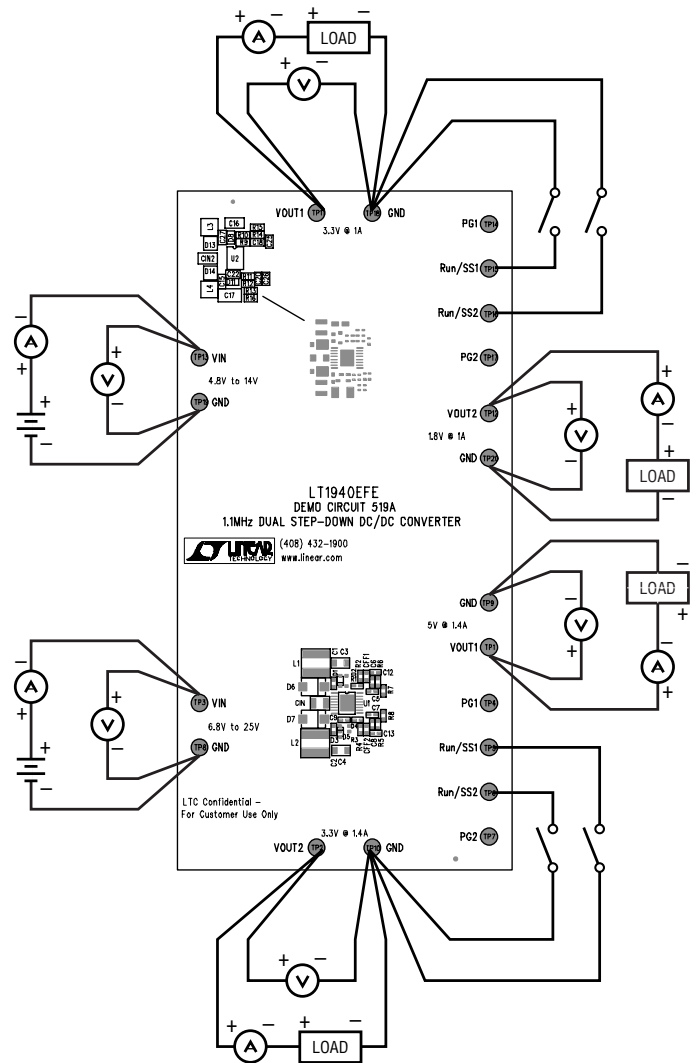

Figure 5. Proper Measurement Equipment Setup

### CUSTOMIZING THE BOARD

The components used in the demonstration circuits are optimized for wide input voltage ranges. Nevertheless, the bandwidths can be increased for more specific input voltages, such as  $12V \pm 10\%$  or  $5V \pm 10\%$ , by changing the  $V_C$  components, the noise filter caps, the feedforward caps, and the output capacitors. The adjustable feedback resistors allow the output voltages to be customized. The boost diodes D8 and D11 on the small circuit are the only boost diode options on that circuit for minimal space considerations. The anode of D8 is connected to Vout1 (3.3V). The anode of D11 is connected to Vin (4.8V to 14V) since Vout2 is 1.8V and is below 3.0V. The minimum boost voltage required for the internal power switch is 3.0V and that can usually be taken directly from a 3.3V output or greater. However, if the output voltage is below 3.3V, in order to maintain high efficiency, the boost diode should get its voltage from either the input (which is less efficient than a greater than 3.3V output) or another source such as the other output on the board (if it is greater than 3.3V). Since there is not space to make these changes in boost diode location on the small circuit, D8 and D11 should always be used (not customized) and Vout1 should always be

3.3V or greater and Vout 2 can be less than 3.3V. If Vout2 is 3.3V or greater, the small circuit, with D11 installed connecting to the input, will not be as efficient as it could be if D11 was instead connected to Vout2.

The larger, versatile circuit has pad placements built-in for customized output voltages of all acceptable levels. D1 and D3 are connected to Vout1 (5V) and Vout2 (3.3V) respectively since they are both 3.3V or greater and they provide enough boost to saturate the high-side NPN power switches. However, if either output voltage is customized to less than 3.3V, D1 can be removed and replaced by stuffing D2 with the same part. D3 can be removed and replaced by stuffing D4 with the same part. Both D2 and D4 connect the boost to Vin. Additionally, D5 provides a way to replace D3 with a boost diode that is connected to Vout1 in case Vout1 is 3.3V or greater and Vout2 is less than 3.3V.

Make sure that the boost capacitors (C27, C15, C1, C2) have voltage ratings greater than or equal to the output voltage for applications where the boost diode is connected to the output. However, the boost capacitor must have a voltage rating greater than the input voltage whenever the boost diode is connected to the input.

REVISION HISTORY				
ECO	REV	DESCRIPTION	DATE	APPROVED
>	3	PROTO	05-24-02	

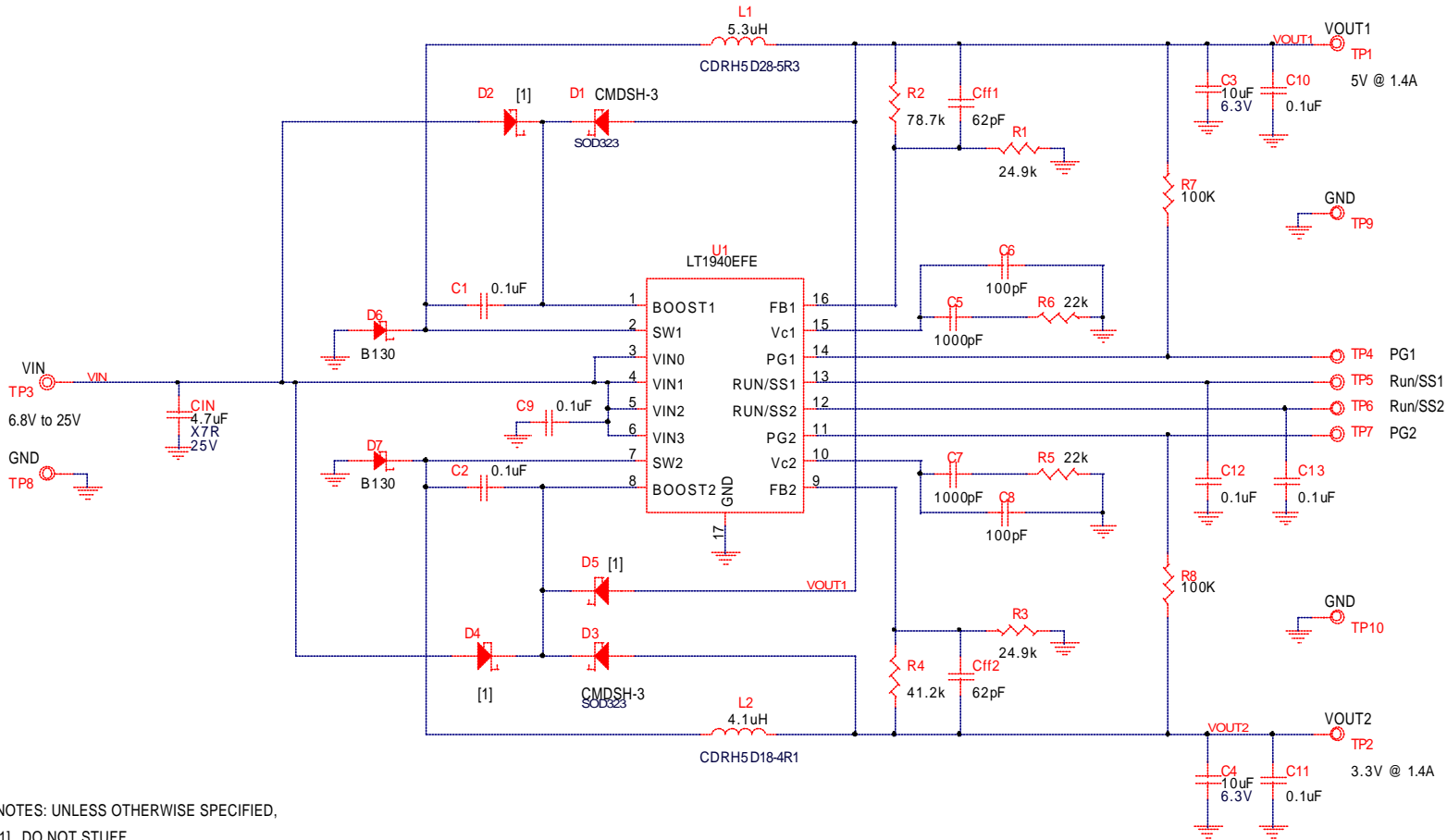

NOTES: UNLESS OTHERWISE SPECIFIED,  
[1] DO NOT STUFF.

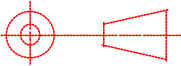
UNLESS OTHERWISE SPECIFIED DIMENSIONS ARE IN INCHES TOLERANCE ON ANGLE --- 2 PLACES --- 3 PLACES --- INTERPRET DIM AND TOL PER ASME Y14.5M-1994	CONTRACT NO.		 1630 McCarty Blvd Milpitas, CA 95035 Phone: (408)4321900 Fax: (408)4340307	
	APPROVALS	DATE		
THIRD ANGLE PROJECTION	DRAWN MEI	05-24-02	TITLE	
	CHECKED		<b>SCH, LT1940EFE 1.1MHz DUAL STEP-DOWN DC/DC CONVERTER</b>	
	APPROVED			SIZE
	ENGINEER			CAGE CODE
DESIGNER			DWG NO	
DO NOT SCALE DRAWING	Monday, July 22, 2002	SCALE: NONE	DC519A	
		FILENAME: 519A-3.DSN	REV 3	
		SHEET 1 OF 2		

REVISION HISTORY				
ECO	REV	DESCRIPTION	DATE	APPROVED
>	3	PROTO	05-24-02	

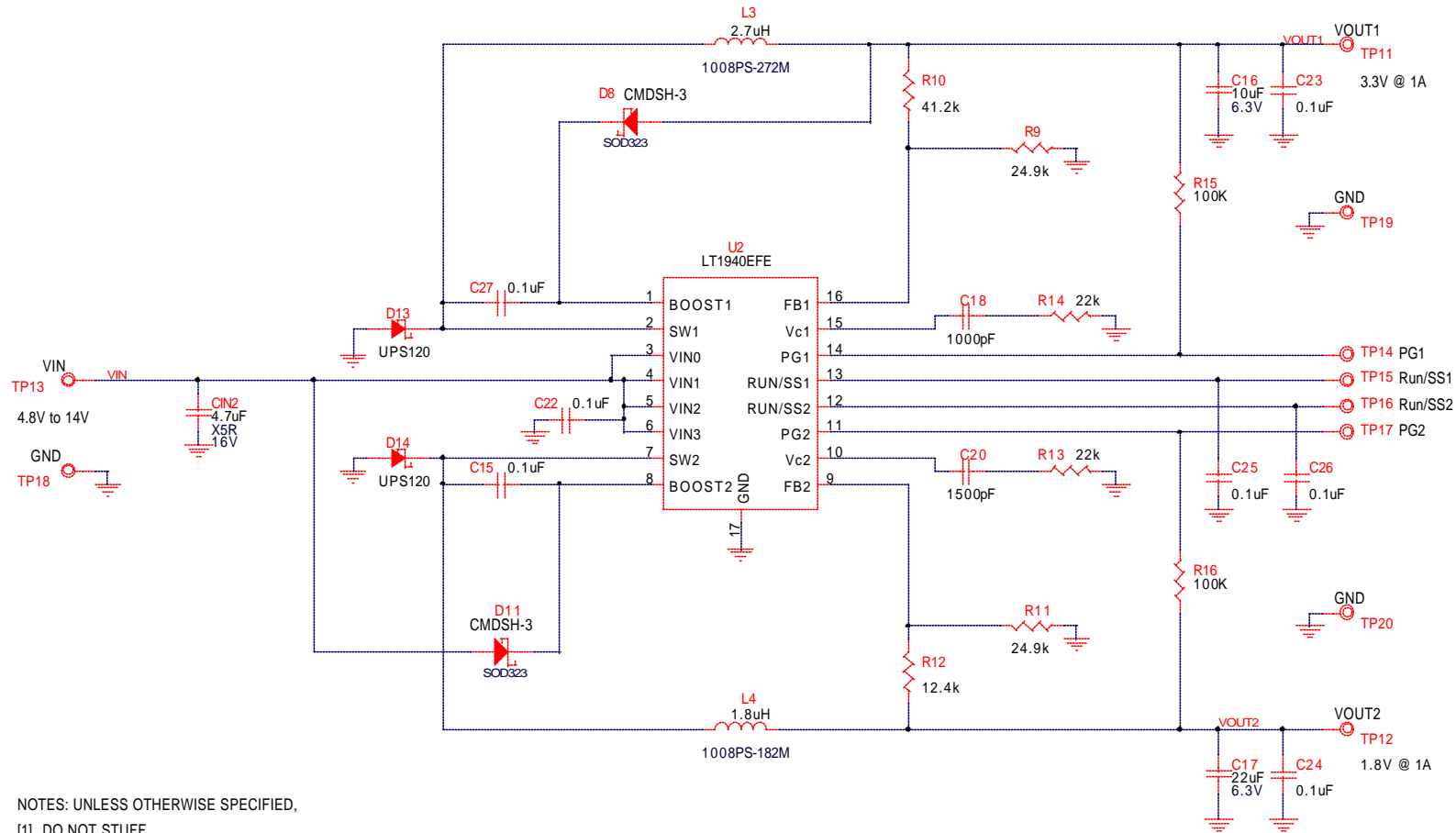

NOTES: UNLESS OTHERWISE SPECIFIED,  
[1] DO NOT STUFF.

UNLESS OTHERWISE SPECIFIED DIMENSIONS ARE IN INCHES TOLERANCE ON ANGLE --- 2 PLACES --- 3 PLACES --- INTERPRET DIM AND TOL PER ASME Y14.5M-1994	CONTRACT NO.		1630 McCarty Blvd Milpitas, CA 95035 Phone: (408)438-1900 Fax: (408)438-0307			
	APPROVALS	DATE				
	THIRD ANGLE PROJECTION	DRAWN MEI	05-24-02	TITLE SCH, LT1940EFE 1.1MHz DUAL STEP-DOWN DC/DC CONVERTER		
		CHECKED				
	APPROVED					
	ENGINEER		SIZE	CAGE CODE	DWG NO	REV
	DESIGNER		Custom		DC519A	3
DO NOT SCALE DRAWING	Monday, July 22, 2002		SCALE NONE	FILENAME: 519A-3.DSN	SHEET 2	OF 2

REVISION HISTORY				
ECO	REV	DESCRIPTION	DATE	APPROVED
>	3	RELEASE	10/31/02	

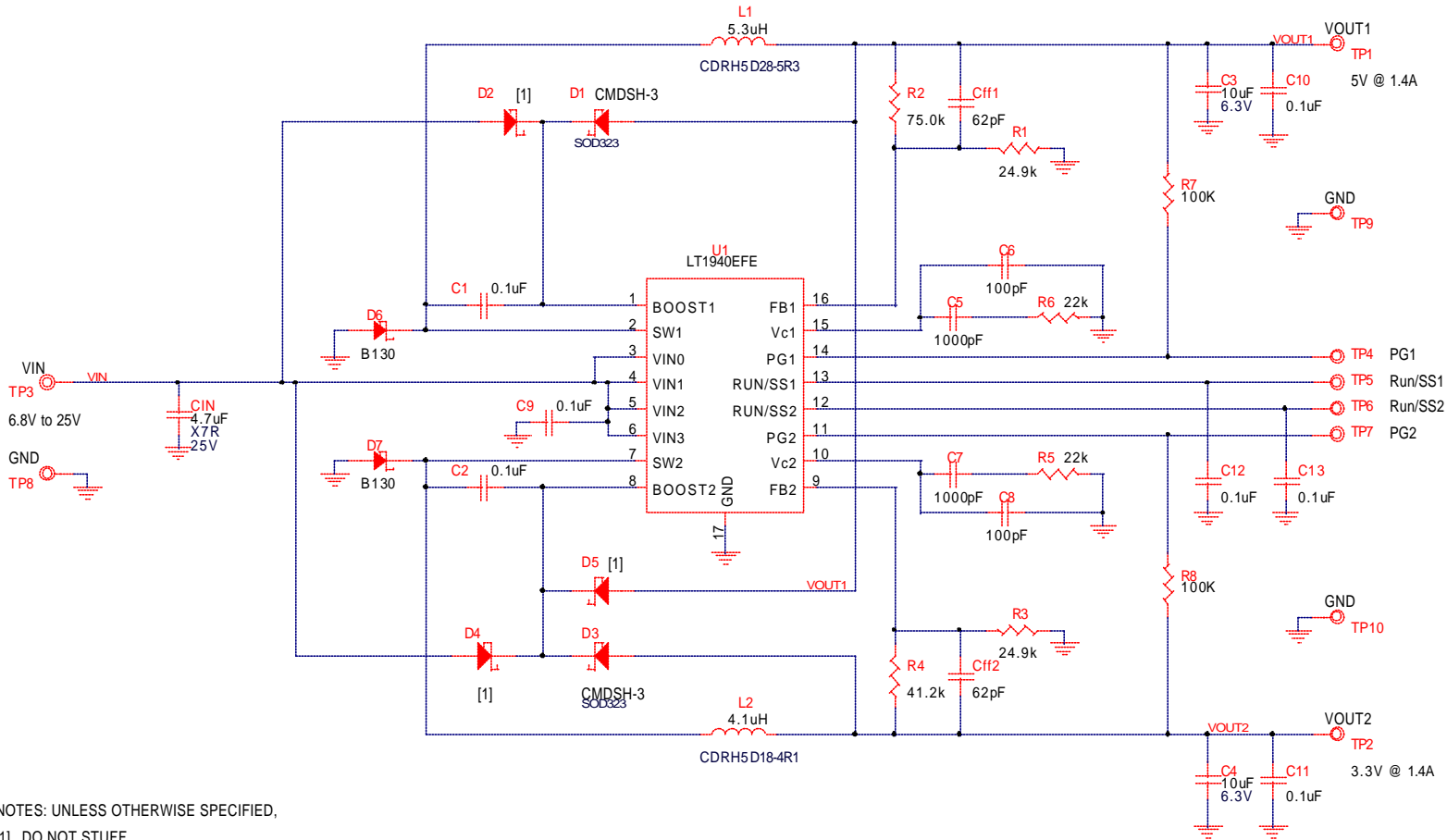

NOTES: UNLESS OTHERWISE SPECIFIED,  
[1] DO NOT STUFF.

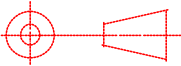
UNLESS OTHERWISE SPECIFIED DIMENSIONS ARE IN INCHES TOLERANCE ON ANGLE --- 2 PLACES --- 3 PLACES --- INTERPRET DIM AND TOL PER ASME Y14.5M-1994	CONTRACT NO.		 1630 McCarty Blvd Milpitas, CA 95035 Phone: (408)4321900 Fax: (408)4340307
	APPROVALS	DATE	
THIRD ANGLE PROJECTION	DRAWN MEI	05-24-02	TITLE
	CHECKED		SCH, LT1940EFE 1.1MHz DUAL STEP-DOWN DC/DC CONVERTER
APPROVED	ENGINEER		SIZE
DESIGNER			Custom
DO NOT SCALE DRAWING	Thursday, October 31, 2002	SCALE: NONE	CAGE CODE
		FILENAME: 519A-3.DSN	DWG NO
		SHEET 1 OF 2	DC519A
			REV 3

REVISION HISTORY				
ECO	REV	DESCRIPTION	DATE	APPROVED
>	3	RELEASE	10/31/02	

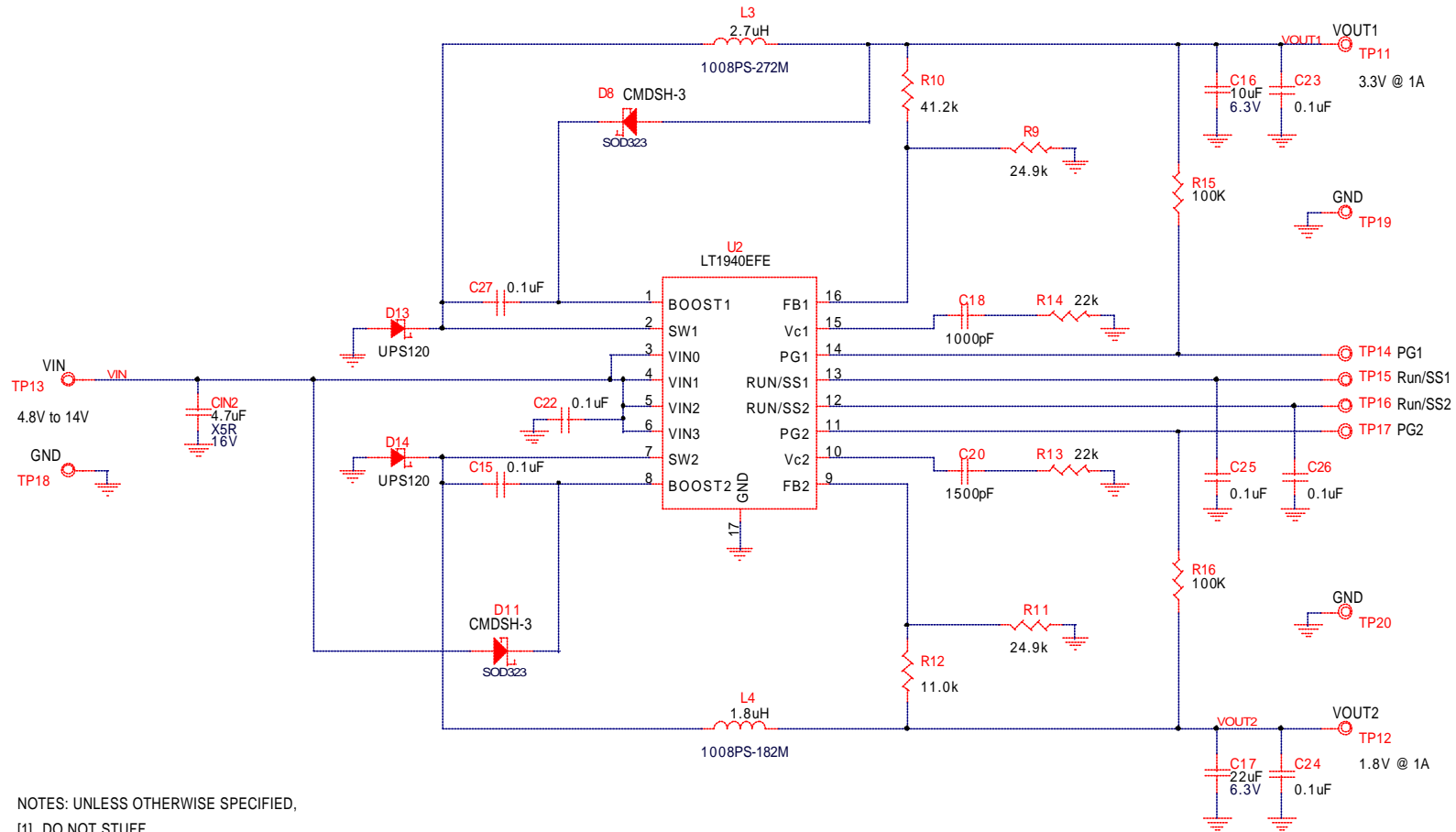

NOTES: UNLESS OTHERWISE SPECIFIED,  
[1] DO NOT STUFF.

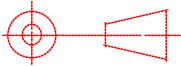
UNLESS OTHERWISE SPECIFIED DIMENSIONS ARE IN INCHES TOLERANCE ON ANGLE --- 2 PLACES --- 3 PLACES --- INTERPRET DIM AND TOL PER ASME Y14.5M-1994	CONTRACT NO.		 1630 McCarty Blvd Milpitas, CA 95035 Phone: (408) 438-1900 Fax: (408) 438-0307
	APPROVALS	DATE	
	DRAWN: MEI	05-24-02	
THIRD ANGLE PROJECTION	CHECKED		TITLE
	APPROVED		SCH, LT1940EFE 1.1MHz DUAL STEP-DOWN DC/DC CONVERTER
	ENGINEER		SIZE
	DESIGNER		Custom
			CAGE CODE
			DWG NO
			DC519A
			REV
			3
DO NOT SCALE DRAWING	Thursday, October 31, 2002	SCALE: NONE	FILENAME: 519A-3.DSN
		SHEET	2 OF 2



Item	Qty	Ref	Desc	Part Number
1	1	CIN	CAP, X7R 4.7uF 25V 20% 1210	TDK C3225X7R1E475M
2	1	CIN2	CAP, X5R 4.7uF 16V 10% 1206	TAIYO YUDEN EMK316BJ475KL
3	2	Cff1,Cff2	CAP, NPO 62pF 25V 5% 0603	AVX 06033A620JAT
4	8	C1,C2,C9,C12,C13,C15,C22, C27	CAP, X7R 0.1uF 16V 10% 0603	AVX 0603YC104KAT
5	2	C4,C3	CAP, X5R 10uF 6.3V 20% 1206	TAIYO YUDEN JMK316BJ106ML-T
6	2	C5,C7	CAP, X7R 1000pF 50V 5% 0603	AVX 06035C102JAT2A
7	2	C6,C8	CAP, NPO 100pF 50V 5% 0603	AVX 06035A101JAT
8	0	C10,C11,C23,C24	CAP, X7R 0.1uF 16V 10% 0603	AVX 0603YC104KAT OPTION
9	1	C16	CAP, X5R 10uF 6.3V 10% 0805	TDK C2012X5R0J106M
10	1	C17	CAP, X5R 22uF 6.3V 10% 1210	TDK C3225X5R0J226M
11	1	C18	CAP, X7R 1000pF 50V 5% 0402	AVX 04025C102JAT
12	1	C20	CAP, X7R 1500pF 50V 5% 0402	AVX 04025C152KAT
13	2	C26,C25	CAP, X5R 0.1uF 10V 10% 0402	AVX 0402ZD104KAT
14	4	D1,D3,D8,D11	DIODE, CMDSH-3 SOD323	CENTRAL CMDSH-3
15	0	D2,D4,D5	DO NOT STUFF	OPTION
16	2	D6,D7	DIODE, B130 SCHOTTKY RECTIFIER 1A	DIODES INC. B130
17	2	D14,D13	DIODE, SCHOTTKY RECTIFIER 1A UPS120	MICROSEMI UPS120
18	1	L1	IND, 5.3uH	SUMIDA CDRH5D28-5R3
19	1	L2	IND, 4.1uH	SUMIDA CDRH5D18-4R1NC
20	1	L3	IND, 2.7uH	COILCRAFT 1008PS-272M
21	1	L4	IND, 1.8uH	COILCRAFT 1008PS-182M
22	2	R1,R3	RES, 24.9k OHMS 1% 1/16W 0603	AAC CR16-2492FM
23	1	R2	RES, 78.7k OHMS 1% 1/16W 0603	AAC CR16-7872FM
24	1	R4	RES, 41.2k OHMS 1% 1/16W 0603	AAC CR16-4122FM
25	2	R6,R5	RES, 22K OHMS 5% 1/16W 0603	AAC CR16-223JM
26	2	R7,R8	RES, 100K OHMS 5% 1/16W 0603	AAC CR16-104JM
27	2	R11,R9	RES, 24.9k OHMS 1% 1/16W 0402	AAC CR05-2492FM
28	1	R10	RES, 41.2k OHMS 1% 1/16W 0402	AAC CR05-4122FM
29	1	R12	RES, 12.4k OHMS 1% 1/16W 0402	AAC CR05-1242FM
30	2	R13,R14	RES, 22K OHMS 5% 1/16W 0402	AAC CR05-223JM
31	2	R15,R16	RES, 100K OHMS 5% 1/16W 0402	AAC CR05-104JM
32	20	TP1-TP20	TURRETS	MILL-MAX-2501-2
33	2	U1,U2	IC, LT1940EFE DUAL STEP-DOWN DC/DC CONVERTER	LINEAR TECH LT1940EFE

Компания «Океан Электроники» предлагает заключение долгосрочных отношений при поставках импортных электронных компонентов на взаимовыгодных условиях!

Наши преимущества:

- Поставка оригинальных импортных электронных компонентов напрямую с производств Америки, Европы и Азии, а так же с крупнейших складов мира;
- Широкая линейка поставок активных и пассивных импортных электронных компонентов (более 30 млн. наименований);
- Поставка сложных, дефицитных, либо снятых с производства позиций;
- Оперативные сроки поставки под заказ (от 5 рабочих дней);
- Экспресс доставка в любую точку России;
- Помощь Конструкторского Отдела и консультации квалифицированных инженеров;
- Техническая поддержка проекта, помощь в подборе аналогов, поставка прототипов;
- Поставка электронных компонентов под контролем ВП;
- Система менеджмента качества сертифицирована по Международному стандарту ISO 9001;
- При необходимости вся продукция военного и аэрокосмического назначения проходит испытания и сертификацию в лаборатории (по согласованию с заказчиком);
- Поставка специализированных компонентов военного и аэрокосмического уровня качества (Xilinx, Altera, Analog Devices, Intersil, Interpoint, Microsemi, Actel, Aeroflex, Peregrine, VPT, Syfer, Eurofarad, Texas Instruments, MS Kennedy, Miteq, Cobham, E2V, MA-COM, Hittite, Mini-Circuits, General Dynamics и др.);

Компания «Океан Электроники» является официальным дистрибьютором и эксклюзивным представителем в России одного из крупнейших производителей разъемов военного и аэрокосмического назначения «JONHON», а так же официальным дистрибьютором и эксклюзивным представителем в России производителя высокотехнологичных и надежных решений для передачи СВЧ сигналов «FORSTAR».



## JONHON

«JONHON» (основан в 1970 г.)

Разъемы специального, военного и аэрокосмического назначения:

(Применяются в военной, авиационной, аэрокосмической, морской, железнодорожной, горно- и нефтедобывающей отраслях промышленности)

«FORSTAR» (основан в 1998 г.)

ВЧ соединители, коаксиальные кабели, кабельные сборки и микроволновые компоненты:

(Применяются в телекоммуникациях гражданского и специального назначения, в средствах связи, РЛС, а так же военной, авиационной и аэрокосмической отраслях промышленности).



Телефон: 8 (812) 309-75-97 (многоканальный)

Факс: 8 (812) 320-03-32

Электронная почта: [ocean@oceanchips.ru](mailto:ocean@oceanchips.ru)

Web: <http://oceanchips.ru/>

Адрес: 198099, г. Санкт-Петербург, ул. Калинина, д. 2, корп. 4, лит. А