

Specification

Part No.	:	GW.05.0E23
Product Name	:	Dual-Band WiFi 2.4/5.8GHz Fakra Code I Mount Hinged Monopole Antenna
Features	:	High Efficiency – With and Without Ground Plane Wi-Fi / Bluetooth / Zigbee Extremely Compact – 69.6mm height, Ø 5mm Aesthetic Look and Feel Fits in places other antennas can't Peak Gain Compliant with Most WiFi Modules Connector: Fakra Code I Beige SMB(F) ROHS Compliant



1. Introduction

The GW.05.0E23 dual band WiFi Hinged Rotatable Fakra Mount Antenna is a high efficiency monopole antenna for Wi-Fi, WLAN, Zigbee, Bluetooth, and 802.11a/b/g/n/ac applications. The direct mount Fakra connector enables a more robust mating to the device compared to a SMA, the locking feature prevents the antenna coming loose due to vibration or shock.

This small antenna fits in places other antennas cannot since the radiating element can be moved and rotated in one hemisphere. For optimized efficiency, keep the element as far away from metal as possible.

Like all monopole antennas, the GW.05 works best when connected directly to the ground-plane of the device main PCB or to the outside of a metal housing. However, it maintains excellent performance even without a ground plane (>50%), making it the best all-around small WiFi terminal antenna on the market. Even compared with other much larger antennas, the GW.05 offers superior high-efficiency wide-band characteristics.

GW.05 is also available as a standard SMA(M) version.

Contact your regional Taoglas facility for support on testing and integration.

2. Specification

Parameter		Wireless Bands	
Straight Position			
Frequency (MHz)		2400~2500	5150~5850
Average Gain (dBi)	In Free Space	-4.63	-2.60
Efficiency (%)		34.49	55.03
Peak Gain (dBi)		3.73	0.64
Average Gain (dBi)	With 15x9cm Ground Plane	-5.27	-4.63
Efficiency (%)		29.74	34.65
Peak Gain (dBi)		0.64	0.34
Average Gain (dBi)	On 30x30cm Metal Plane Edge	-5.53	-4.17
Efficiency (%)		28.23	38.71
Peak Gain (dBi)		2.18	0.19
Average Gain (dBi)	On 30x30cm Metal Plane Center	-4.63	-4.72
Efficiency (%)		34.48	33.78
Peak Gain (dBi)		1.94	1.45
Return Loss (dB)		<-3	<-5

Bent Position 90°			
Average Gain (dBi)	In Free Space	-4.74	-2.12
Efficiency (%)		33.60	61.77
Peak Gain (dBi)		4.09	2.46
Average Gain (dBi)	With 15x9cm Ground Plane	-5.32	-4.43
Efficiency (%)		29.45	36.29
Peak Gain (dBi)		0.38	1.27
Average Gain (dBi)	On 30x30cm Metal Plane Edge	-5.57	-3.50
Efficiency (%)		27.93	44.97
Peak Gain (dBi)		1.42	1.64
Average Gain (dBi)	On 30x30cm Metal Plane Center	-4.72	-3.99
Efficiency (%)		33.81	40.43
Peak Gain (dBi)		1.99	2.37
Return Loss (dB)		<-3	<-5
Radiation		Omni-directional	
Polarization		Linear	
Impedance		50 Ω	
Input Power		10W	
MECHANICAL			
Antenna length		69.6mm	
Antenna Diameter		5mm	
Casing		POM	
Connector		Fakra Code I Beige SMB(F)	
Weight		6g	
ENVIRONMENTAL			
Operation Temperature		-40°C ~ + 85°C	
Storage Temperature		-40°C ~ + 85°C	
Humidity		Non-condensing 65°C 95% RH	

3. Antenna Characteristics

3.1 Testing Setup

Antenna Straight Position



a) In free space

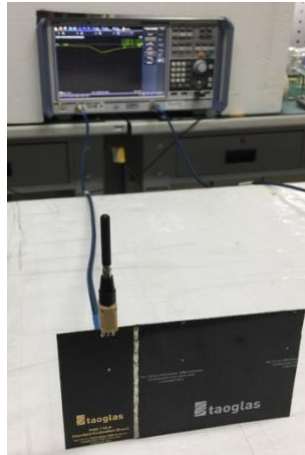

b) with 15*9cm
Ground Plane



c) with 30*30cm
Ground Plane Edge

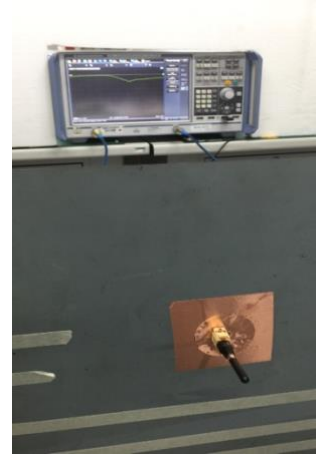

d) with 30*30cm
Ground Plane Center

Antenna Bent 90° Position

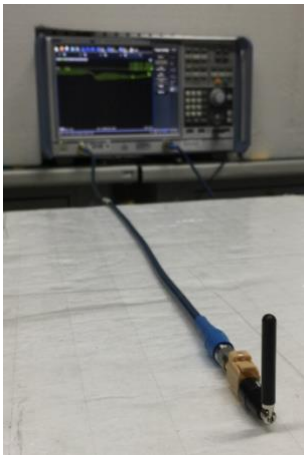

a) In free space



b) with 15*9cm
Ground Plane

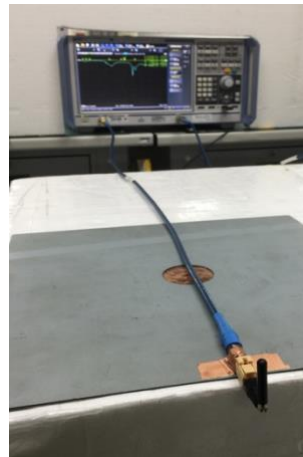

c) with 30*30cm
Ground Plane Edge



d) with 30*30cm
Ground Plane Center

Center

Figure.1 Measurement environments

3.2 Return Loss

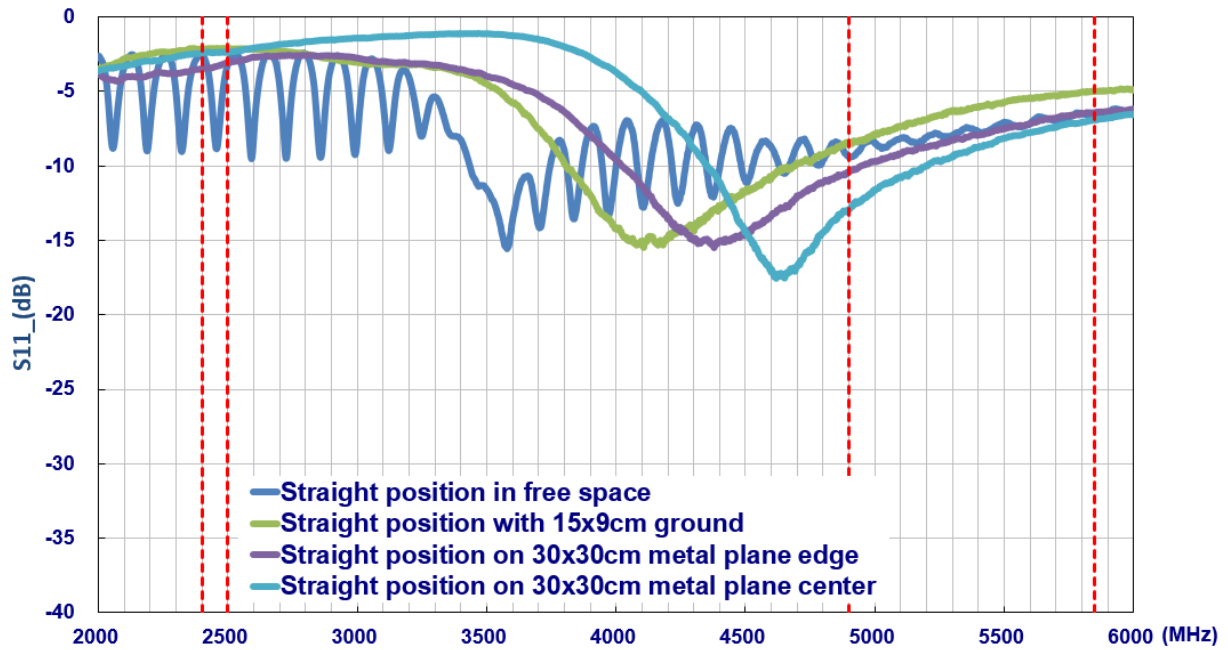

Figure2. Return loss of GW.05 antenna with straight position

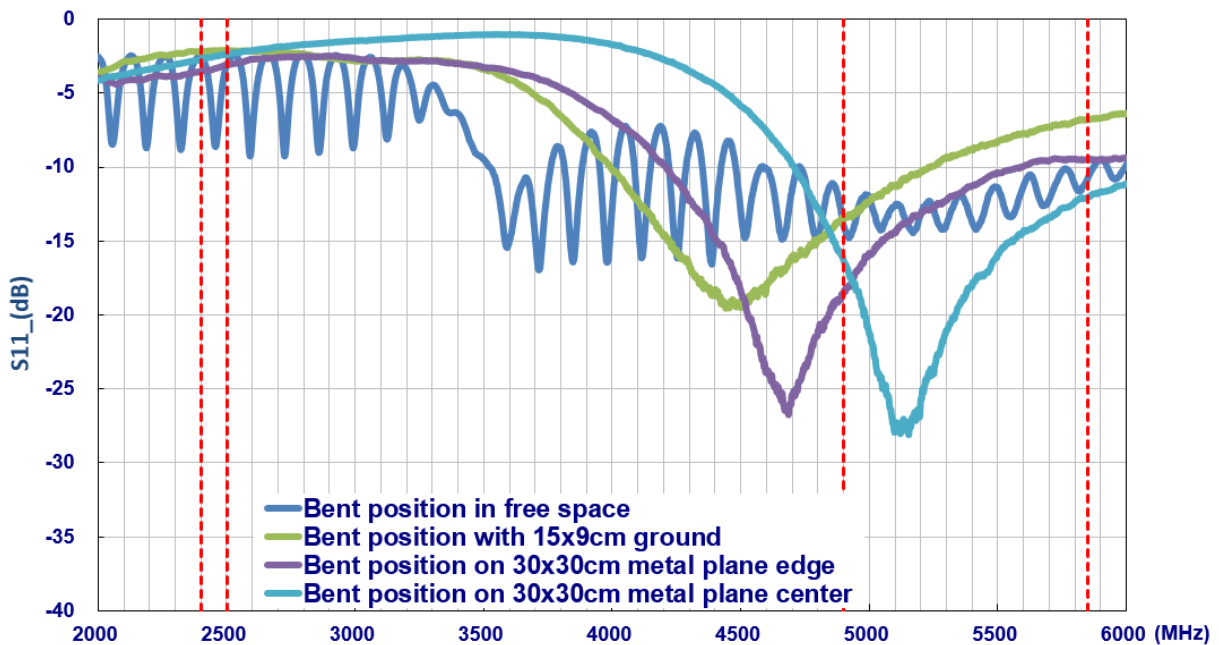

Figure3. Return loss of GW.05 antenna with bent position

3.3 Efficiency

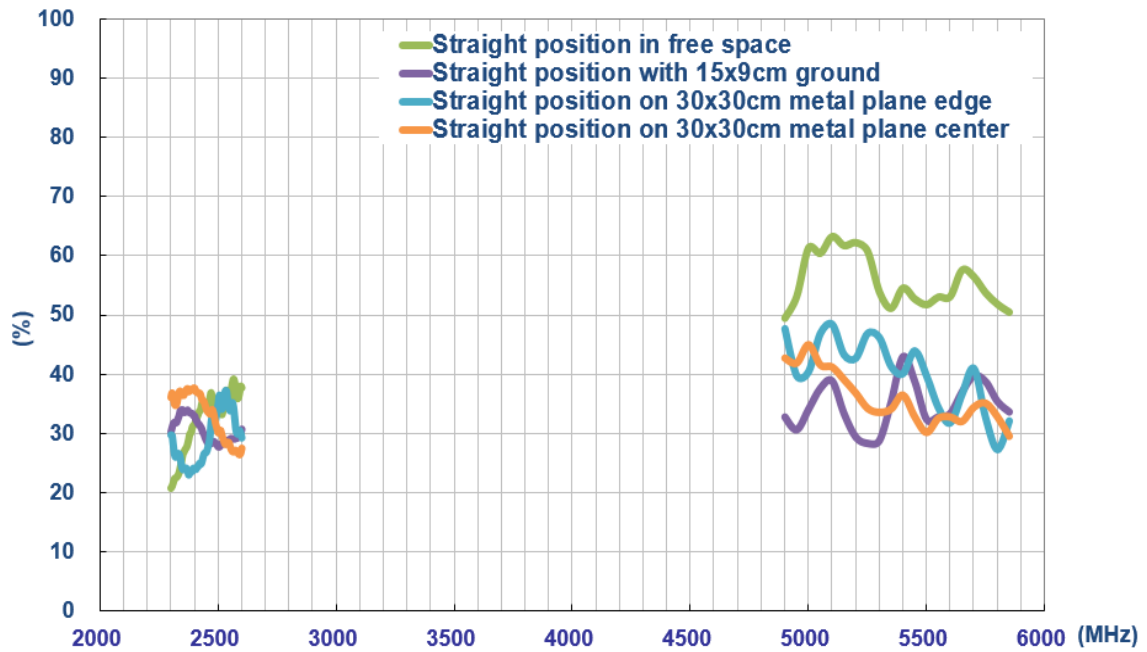

Figure4. Efficiency of GW.05 antenna with straight position

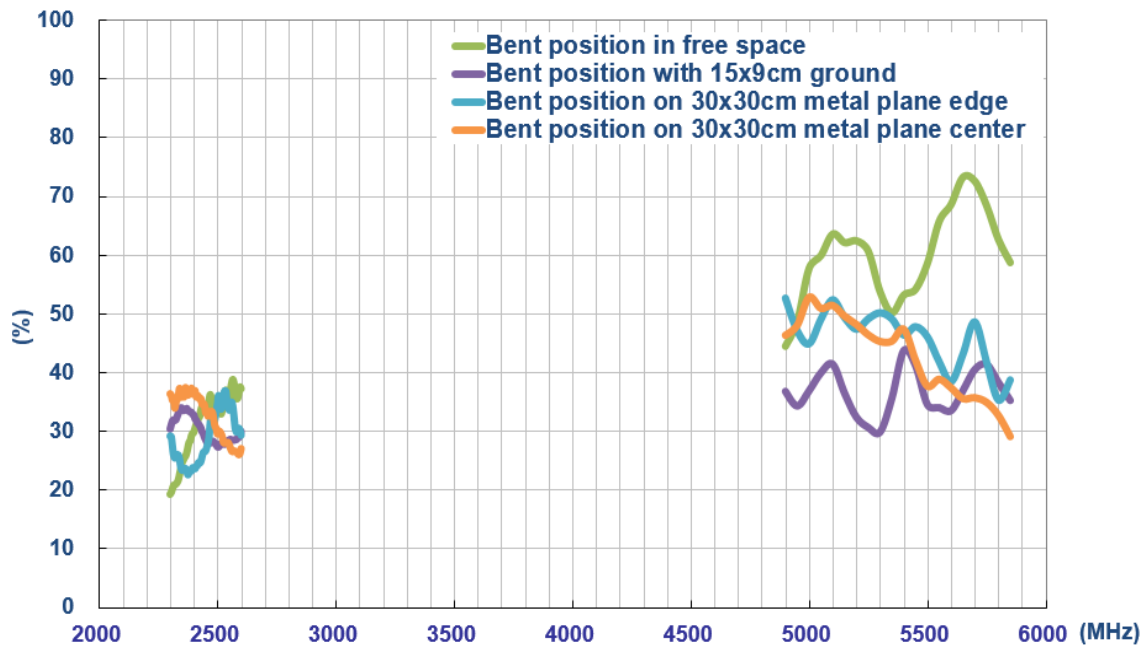

Figure5. Efficiency of GW.05 antenna with bent position

3.4 Peak Gain

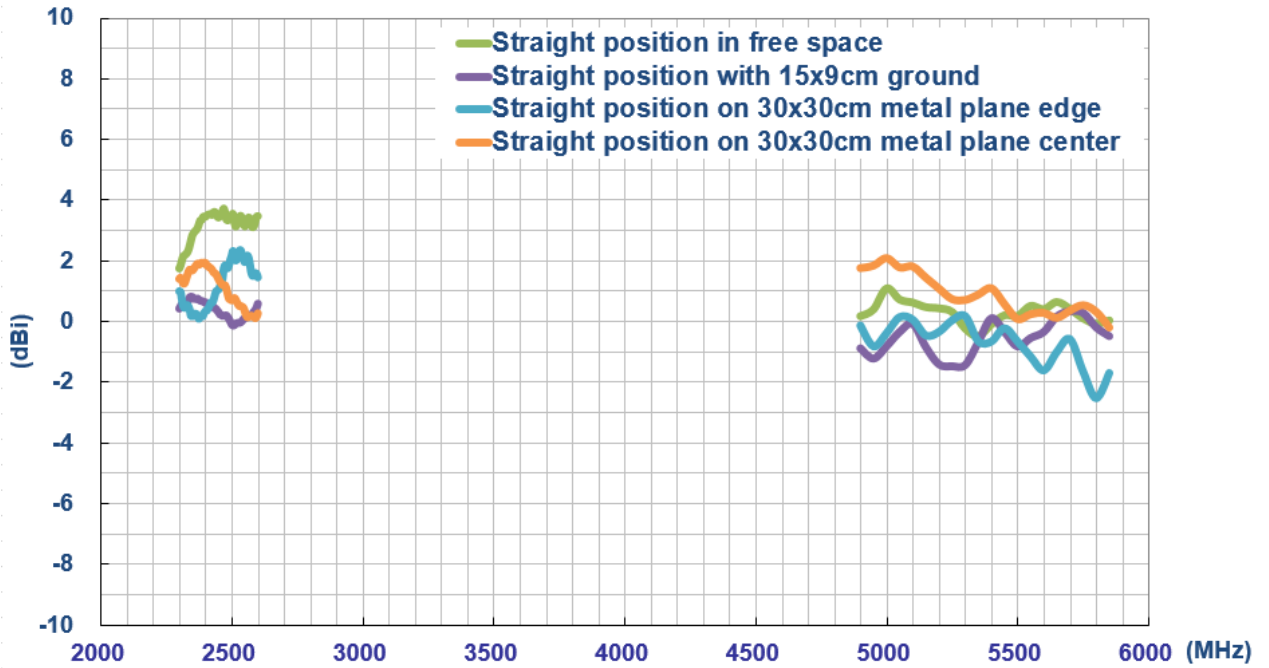

Figure6. Peak gain of GW.05 antenna with straight position

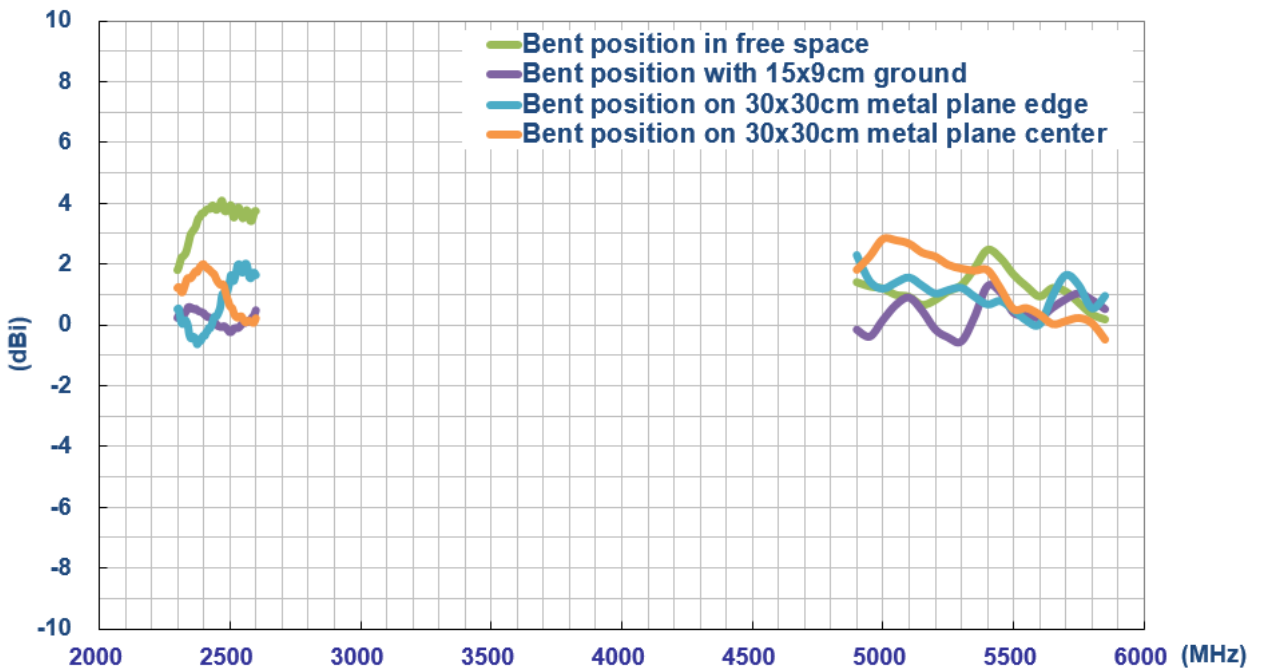

Figure7. Peak gain of GW.05 antenna with bent position

3.5 Average Gain

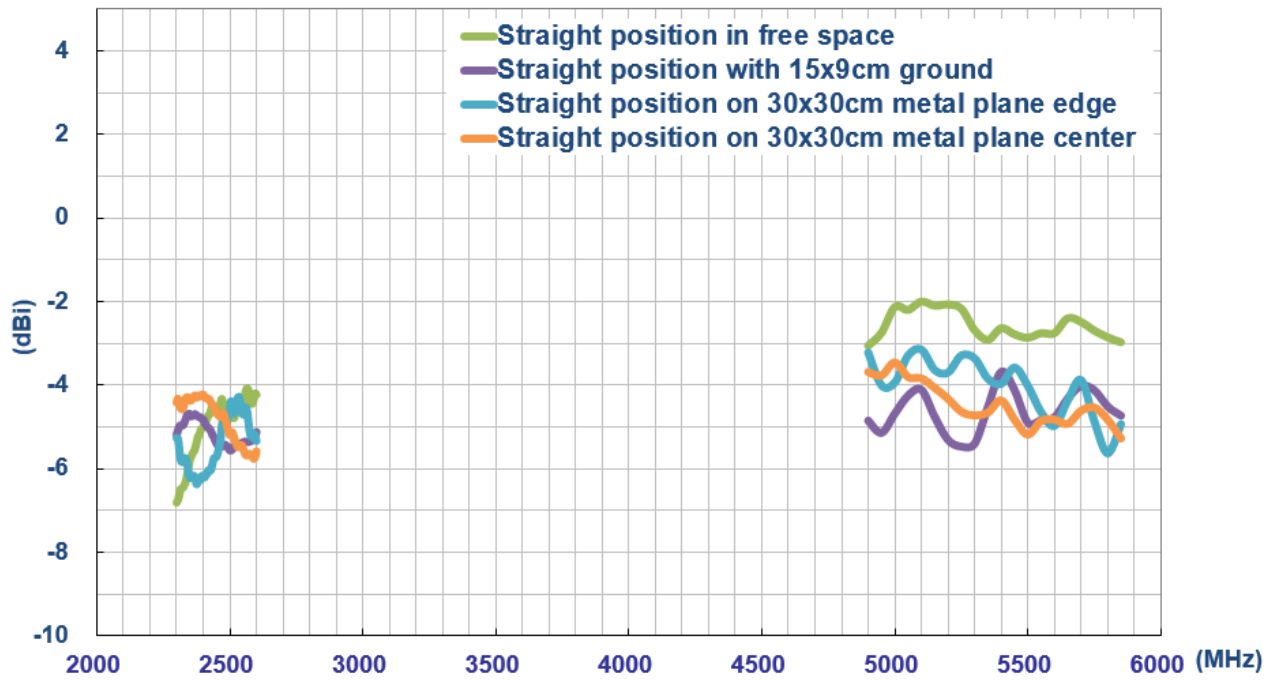

Figure 8. Average gain of GW.05 with antenna straight position

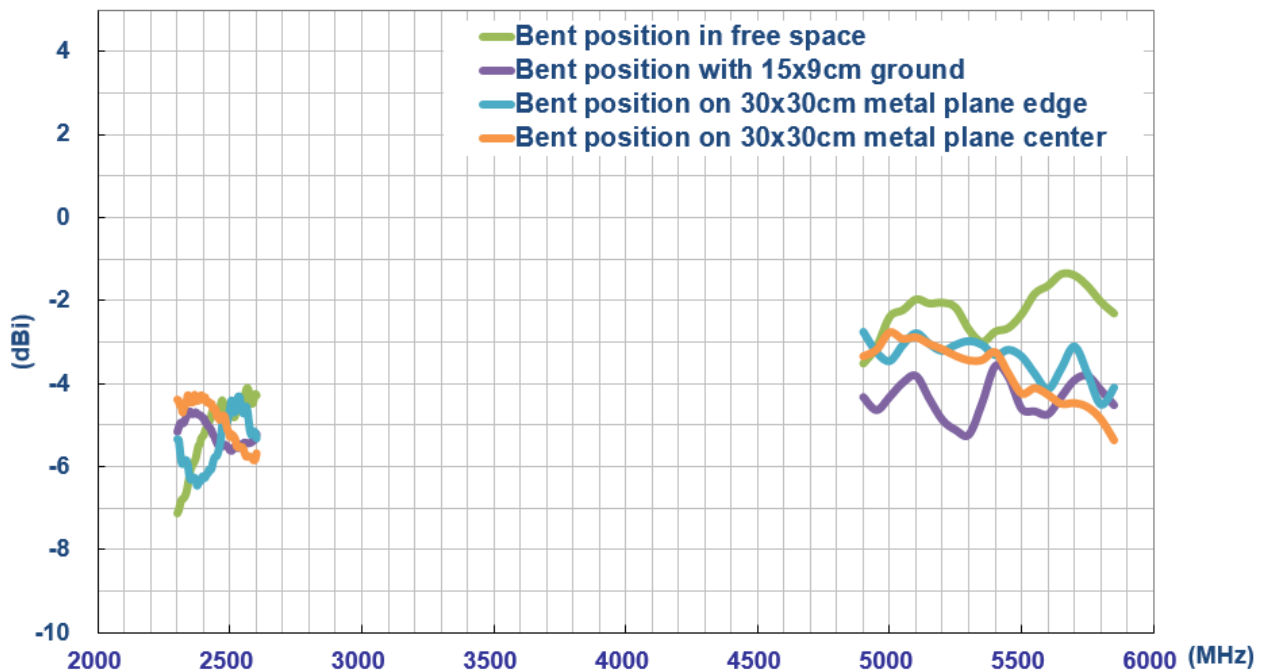
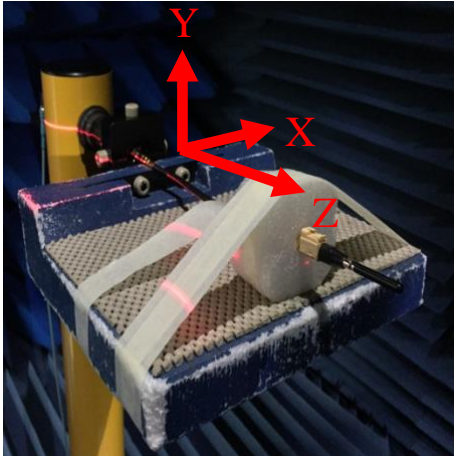

Figure 9. Average gain of GW.05 antenna with bent position

4. Antenna Radiation Patterns

The antenna radiation patterns were measured in a CTIA certified ETS Anechoic Chamber. The measurement setup is shown below.

Antenna with Straight Position



In free space

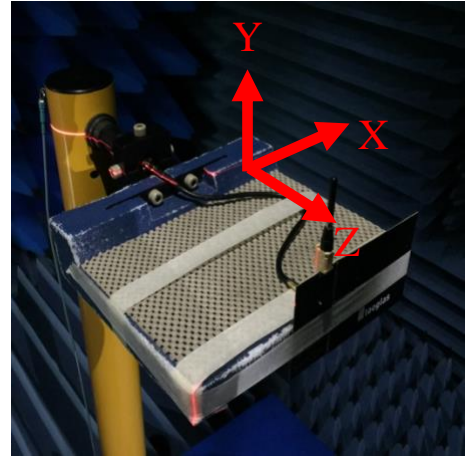

15x9cm ground plane

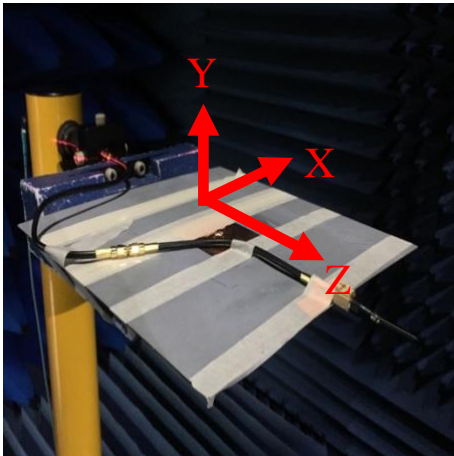

30x30cm metal ground center
edge

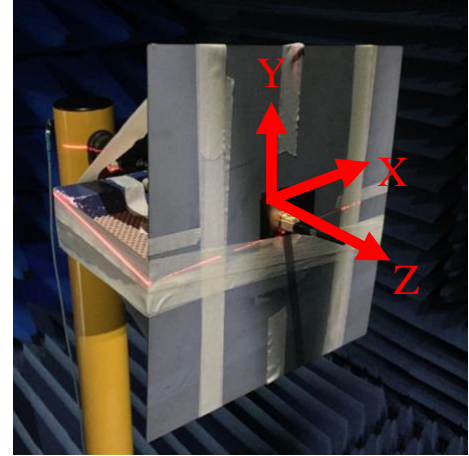

30x30cm metal ground

Antenna Bent Position

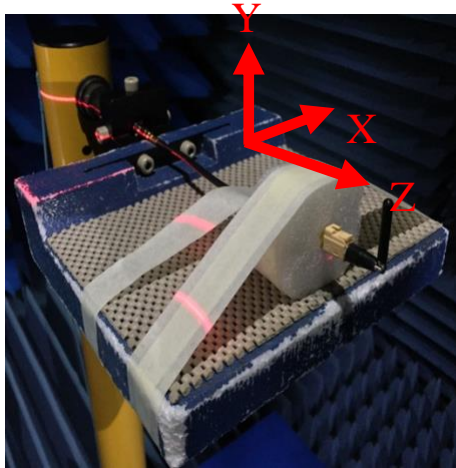

In free space

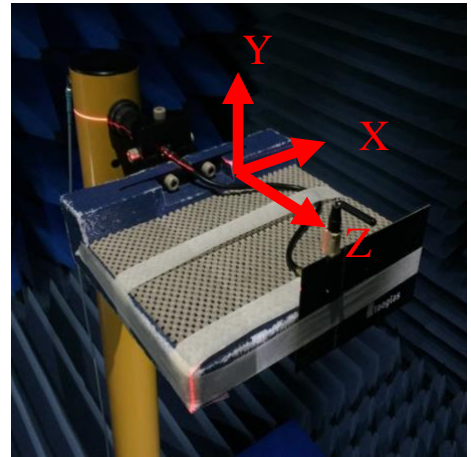

15x9cm ground plane

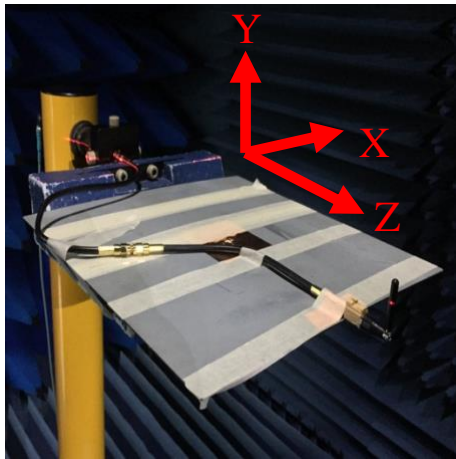

30x30cm metal ground center

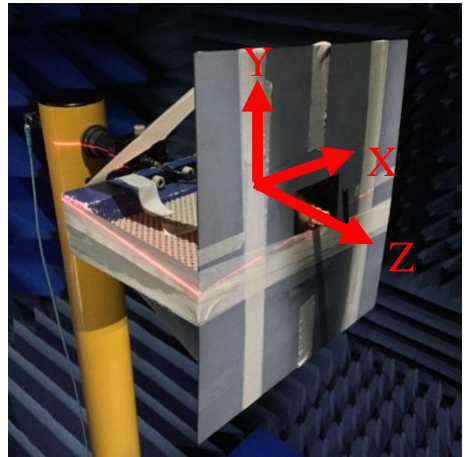

30x30cm metal ground edge

Figure.10. Testing Setup in ETS Anechoic Chamber

4.1 2D Radiation Pattern (Straight position in free space)

XY Plane

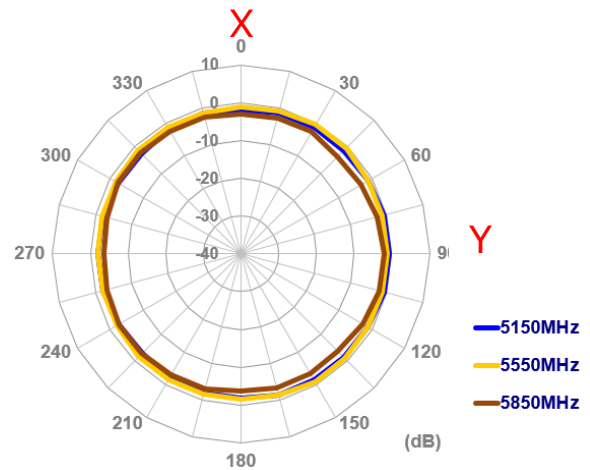
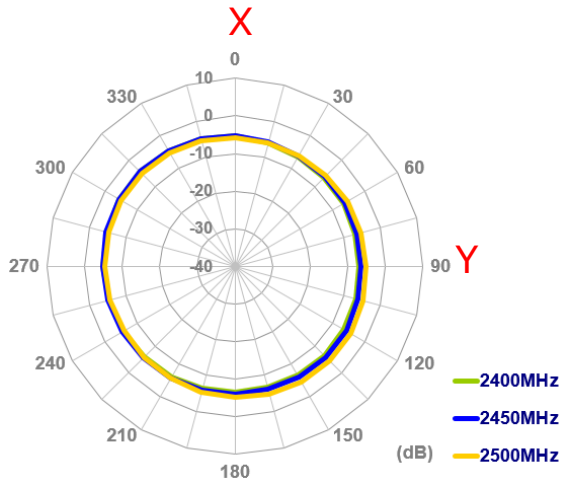

XZ Plane

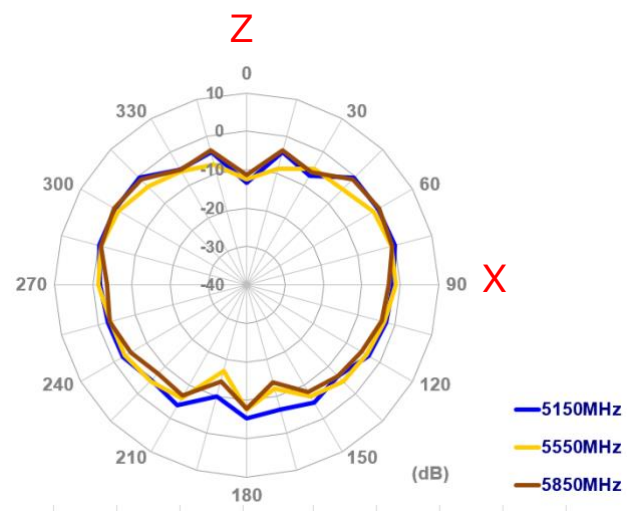
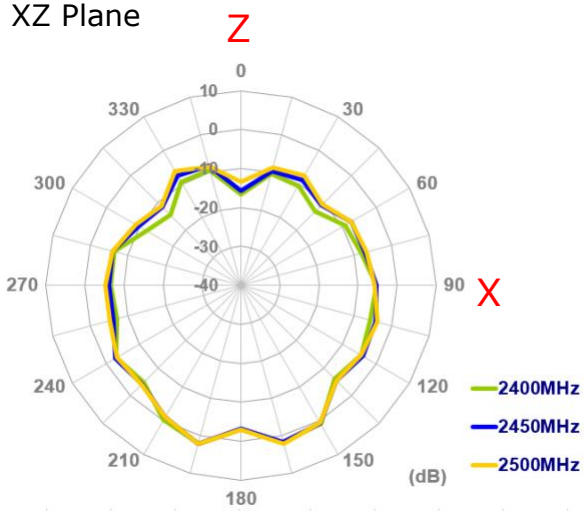

YZ Plane

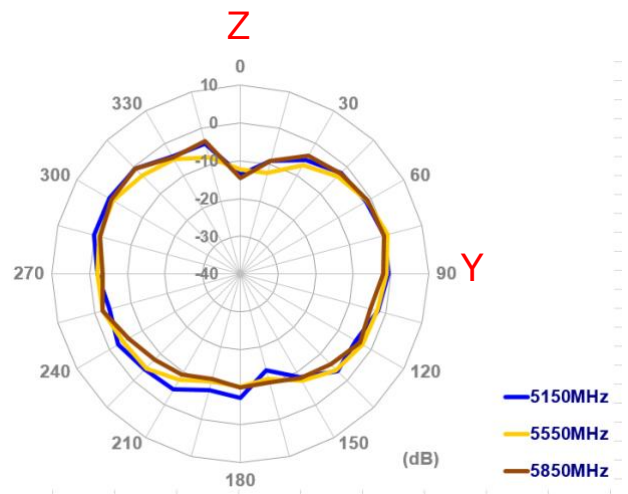
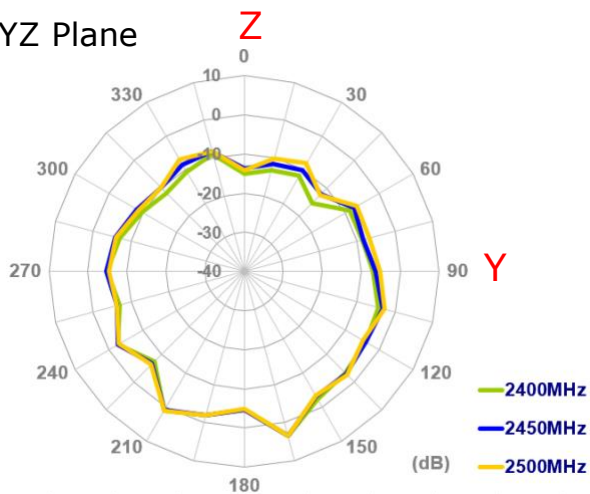

4.2 2D Radiation Pattern (Straight position with 15x9cm ground plane)

XY Plane

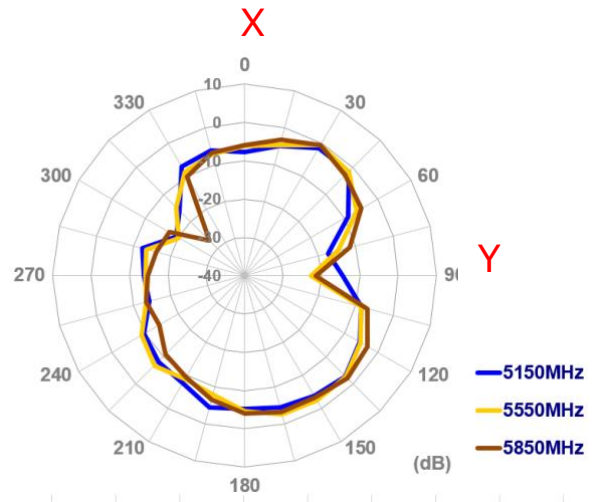
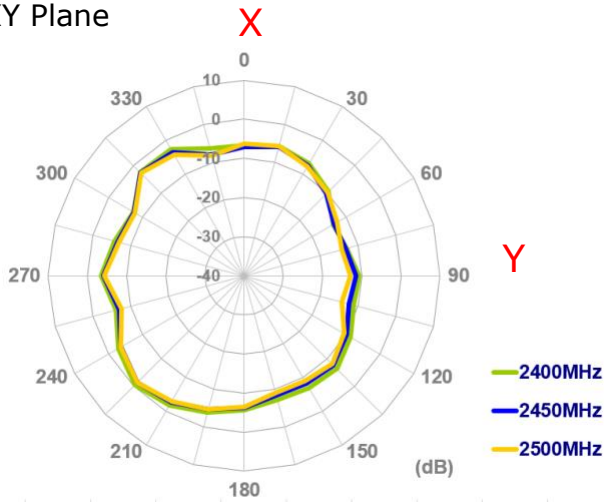

XZ Plane

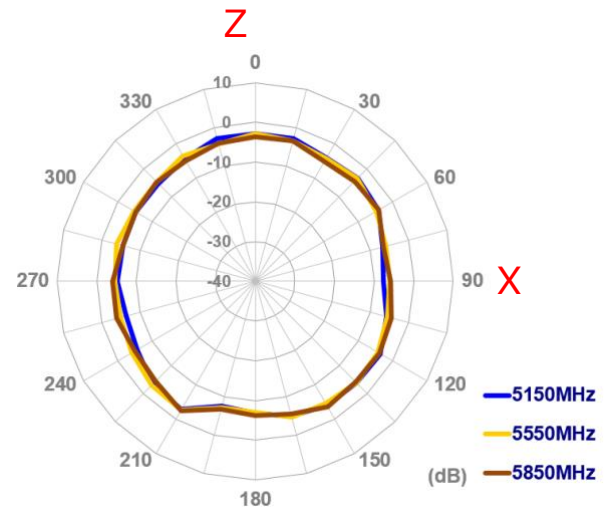
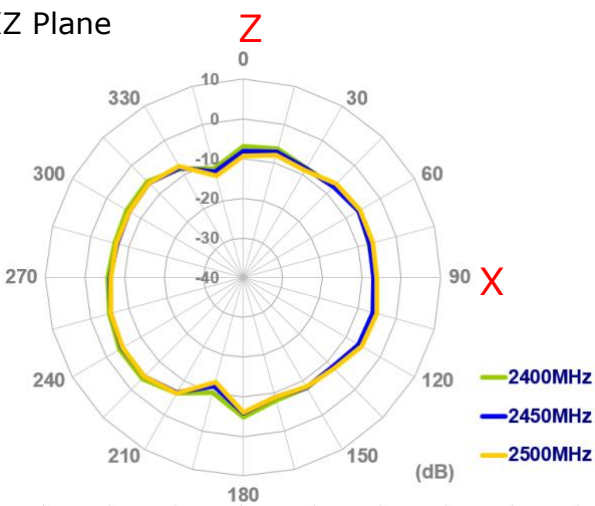

YZ Plane

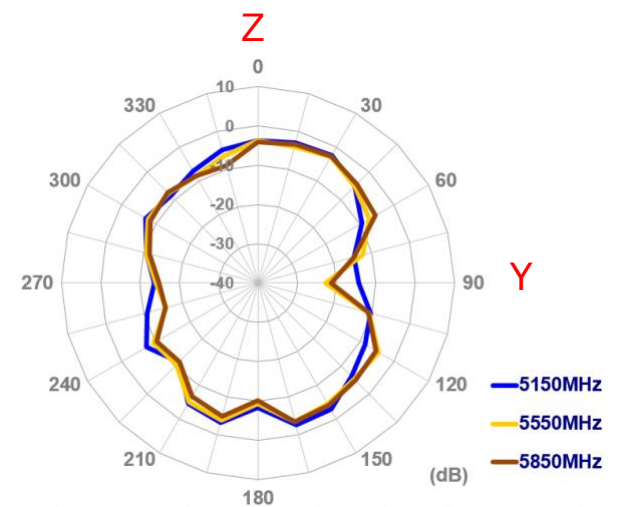
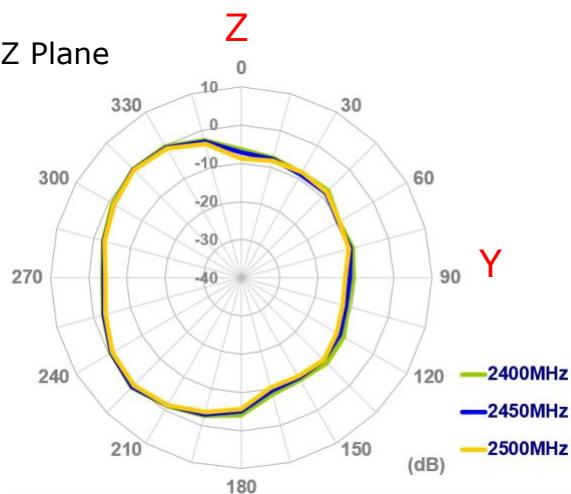

4.3 2D Radiation Pattern (Straight position with 30x30cm ground plane edge)

XY Plane

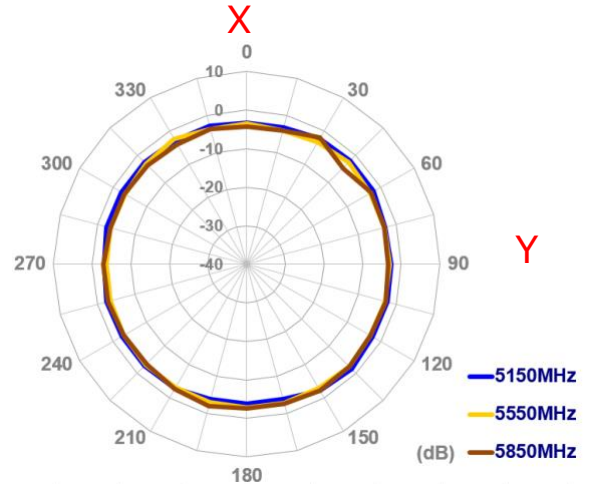
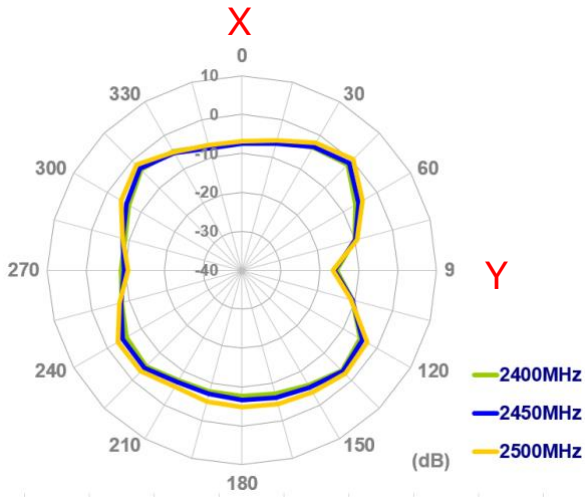

XZ Plane

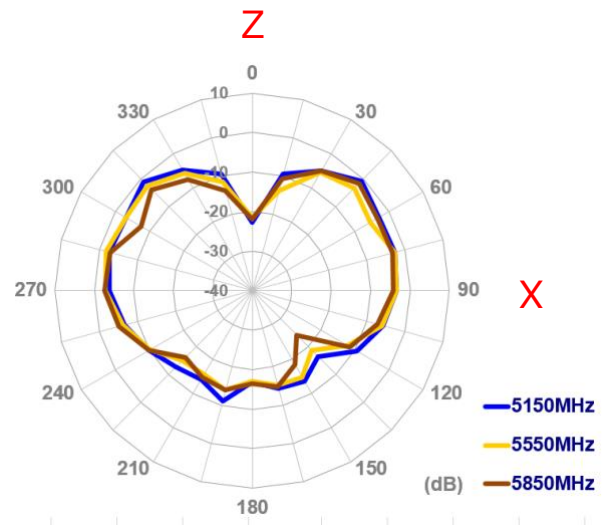
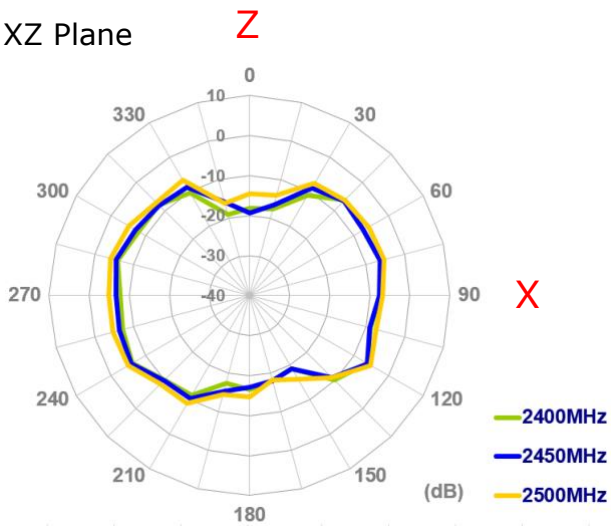

YZ Plane

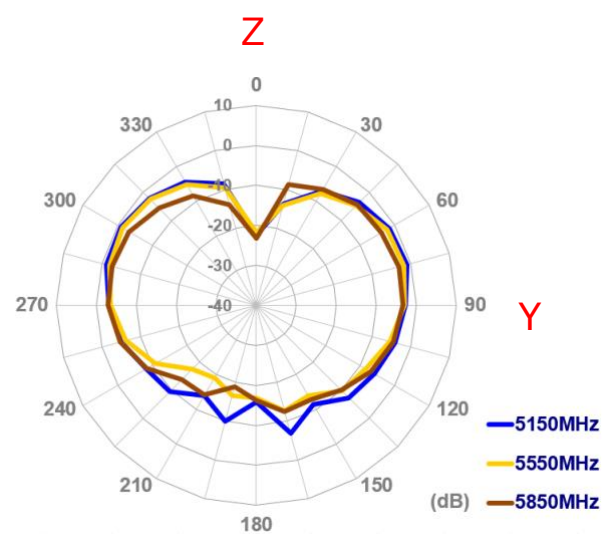
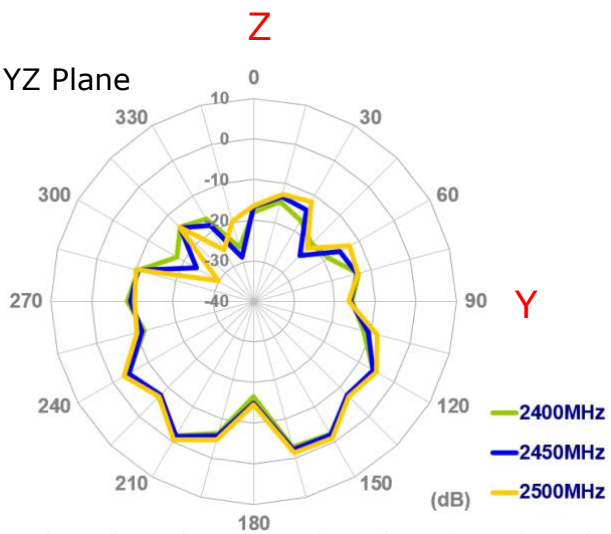

4.3 2D Radiation Pattern (Straight position with 30x30cm ground plane center)

XY Plane

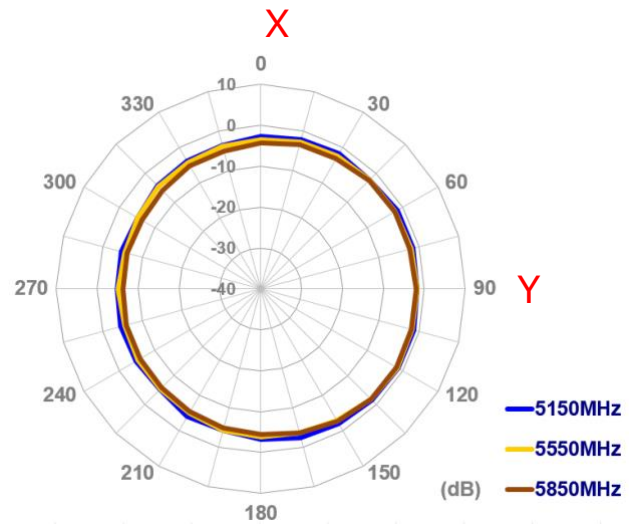
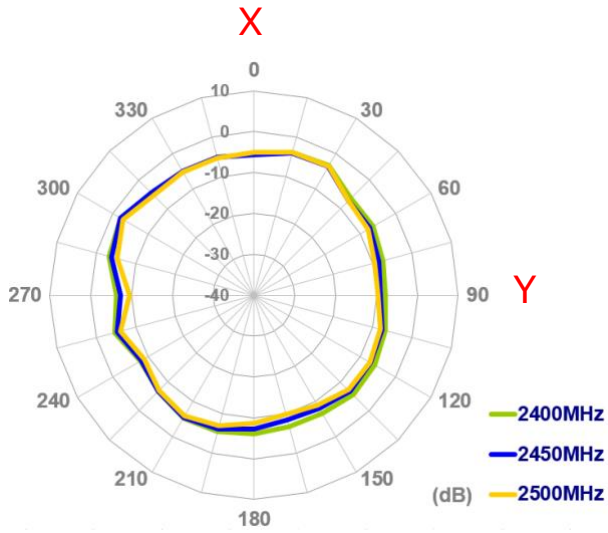

XZ Plane

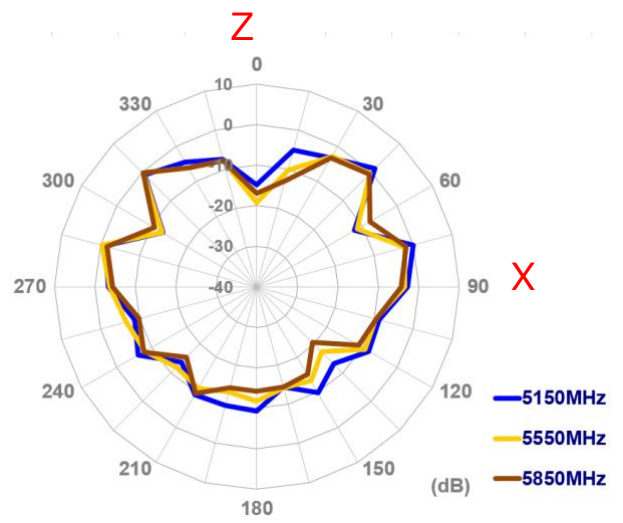
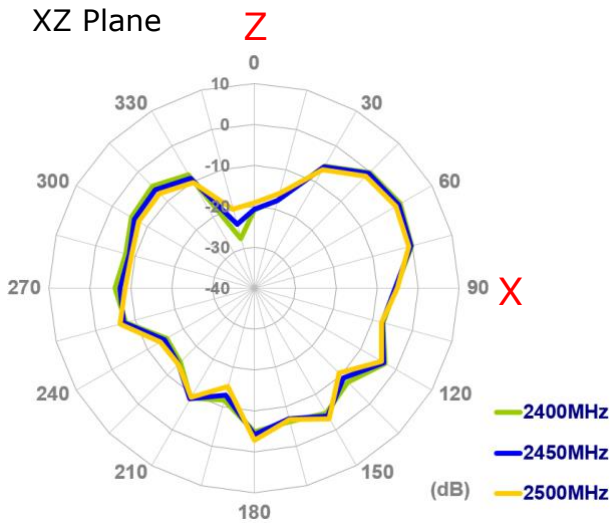

YZ Plane

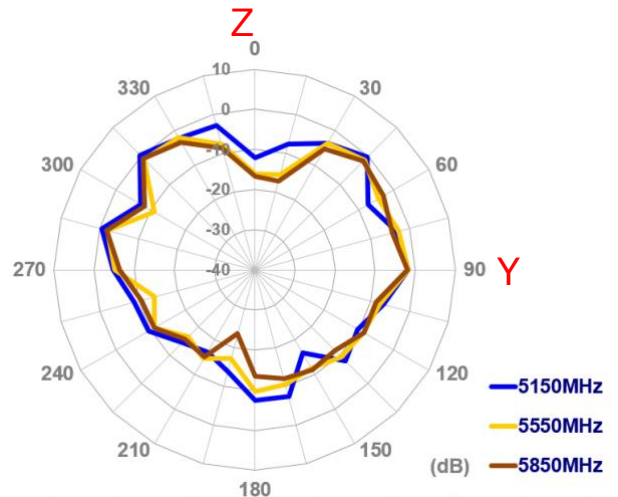
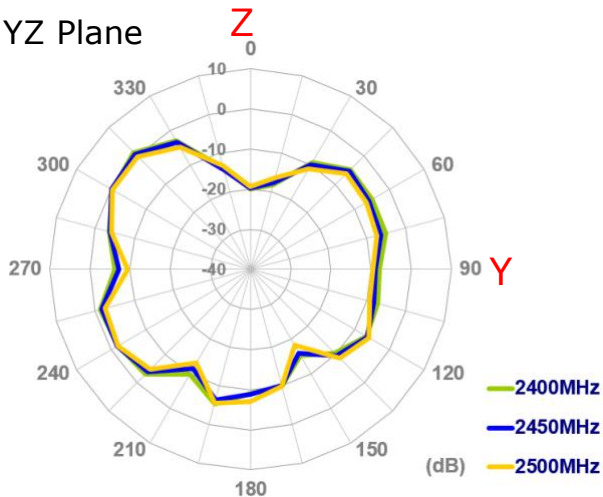

4.4 2D Radiation Pattern (Bent position in free space)

XY Plane

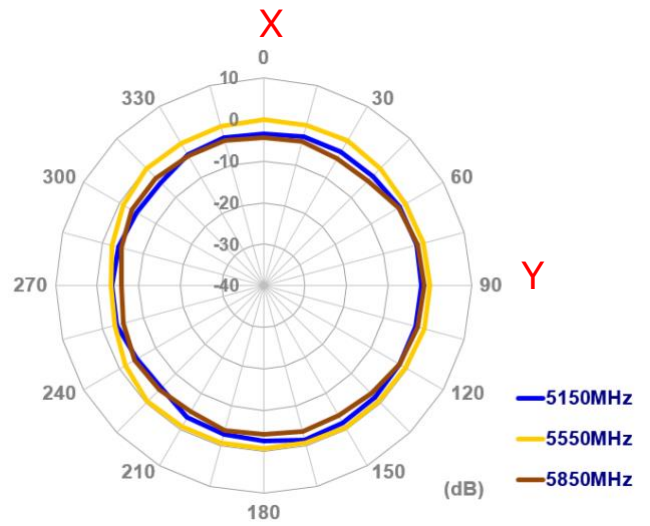
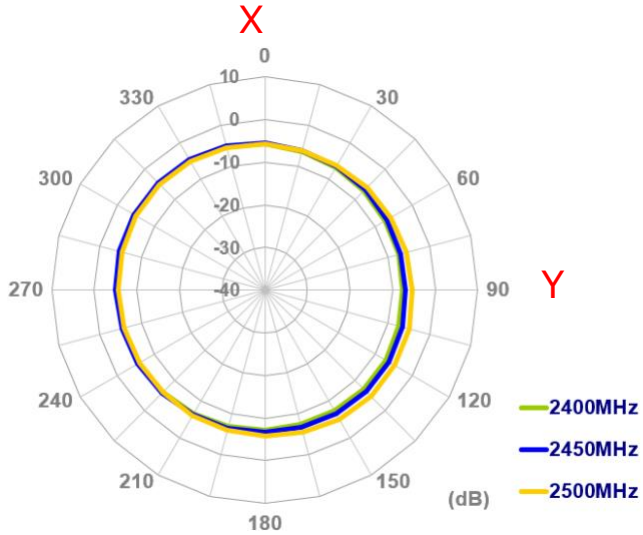

XZ Plane

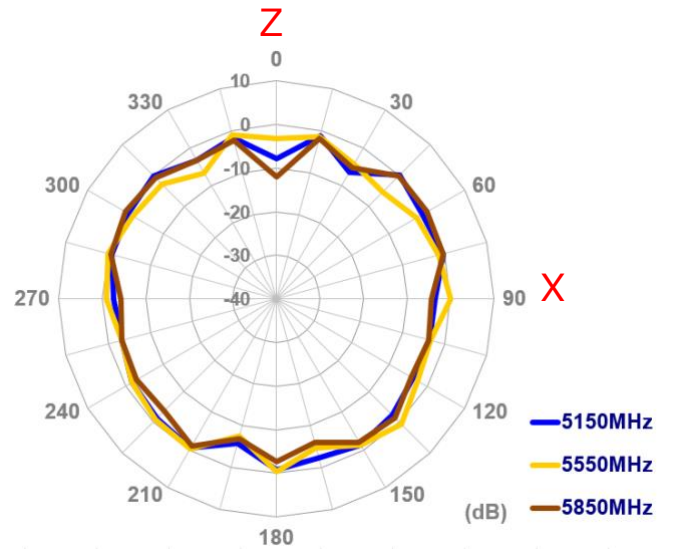
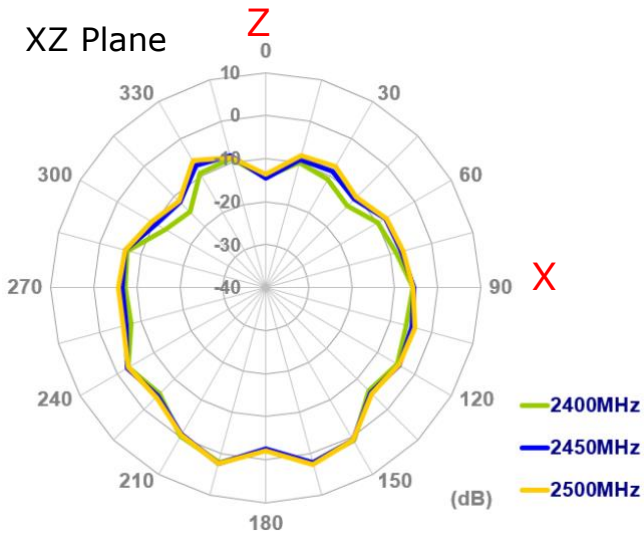

YZ Plane

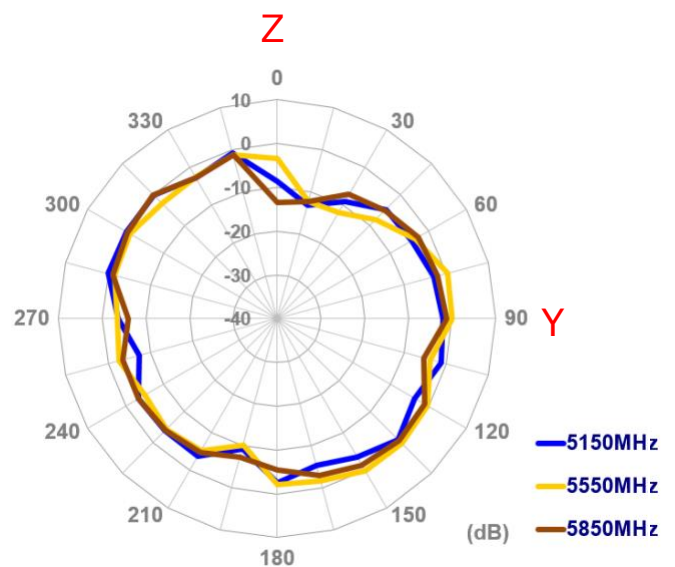
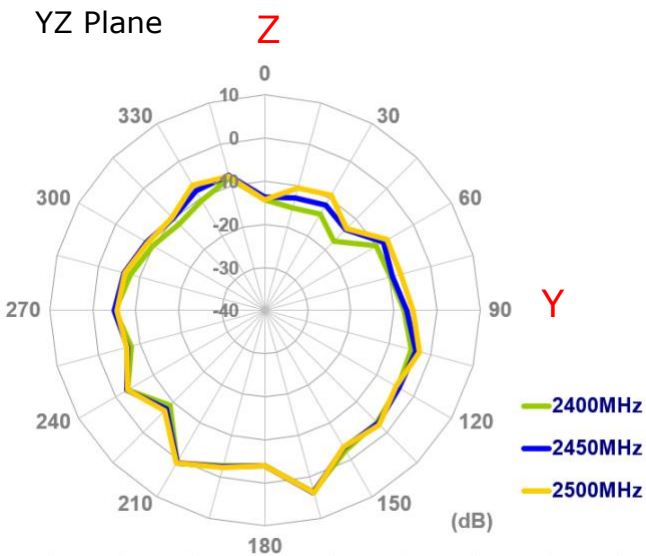

4.5 2D Radiation Pattern (Bent position with 15x9cm ground plane)

XY Plane

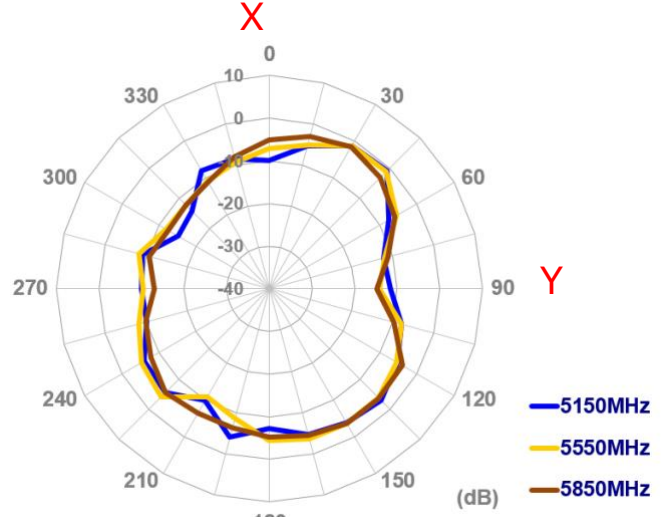
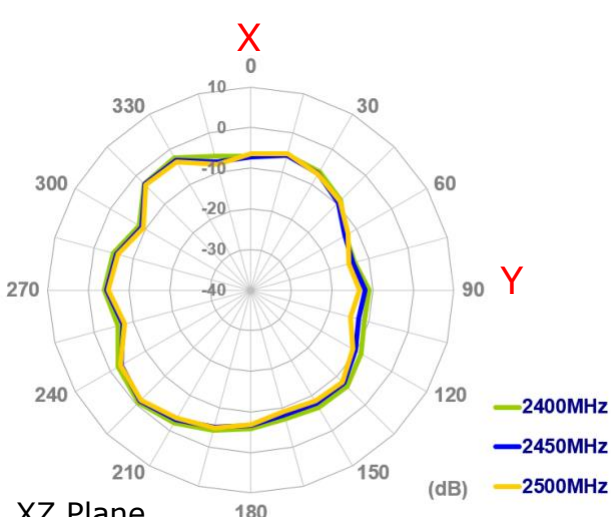

XZ Plane

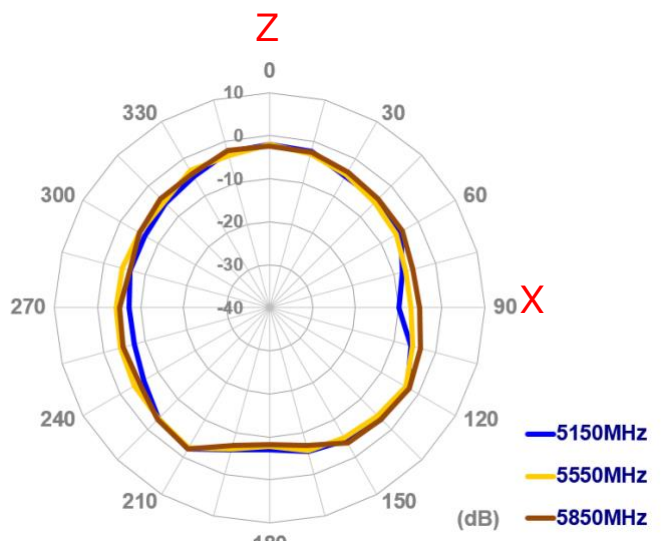
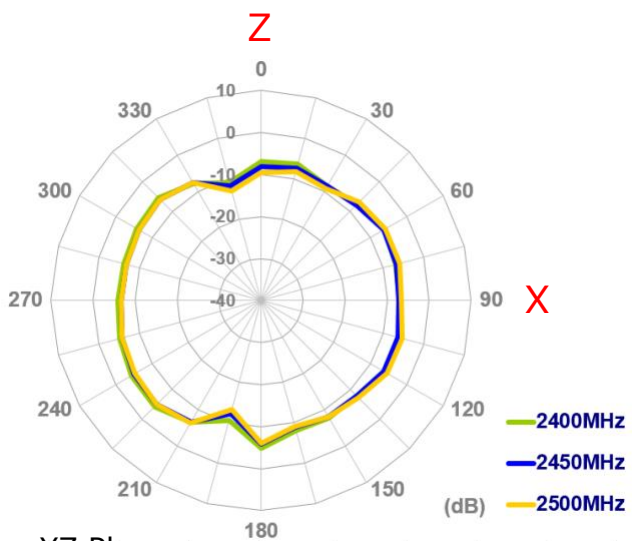

YZ Plane

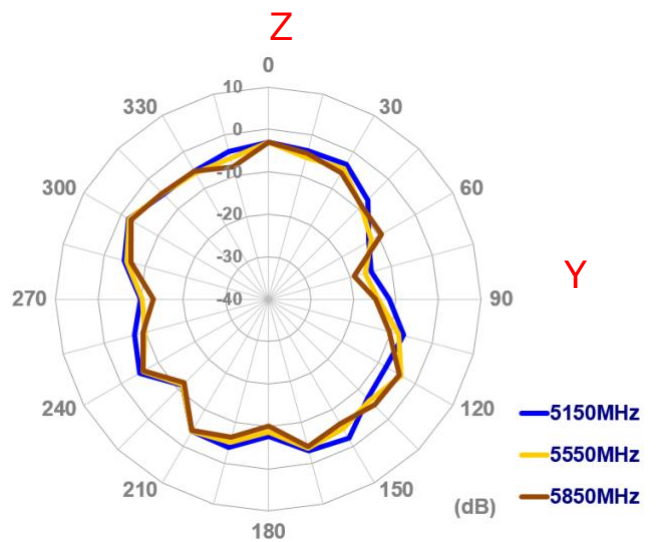
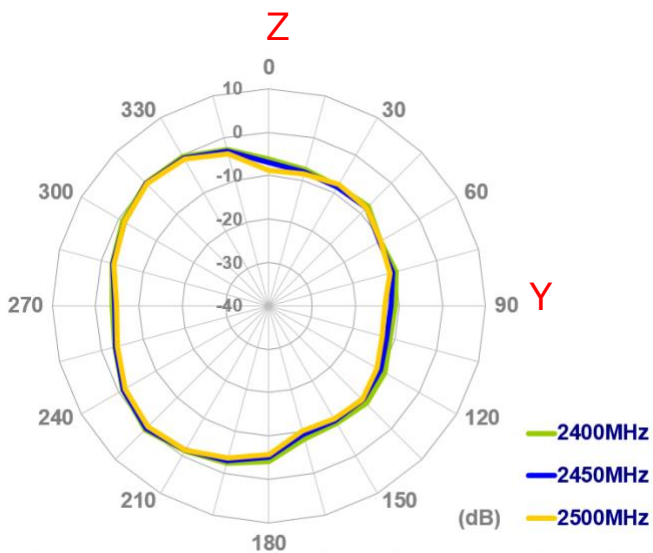

4.7 2D Radiation Pattern (Bent position with 30x30cm ground plane edge)

XY Plane

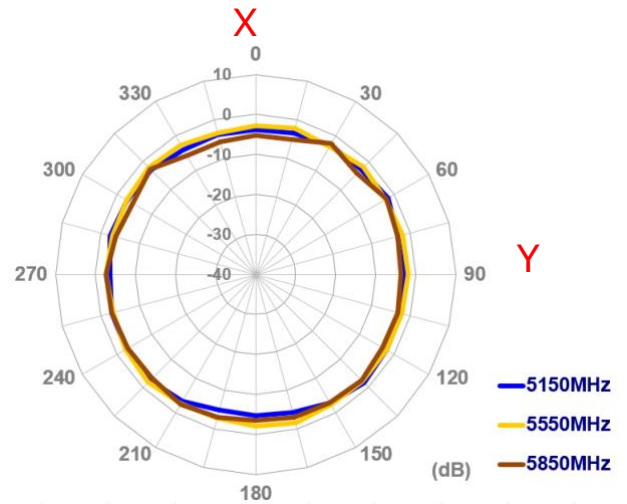
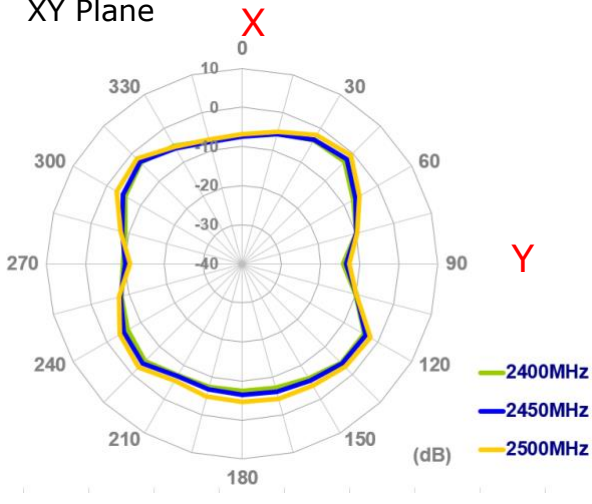

XZ Plane

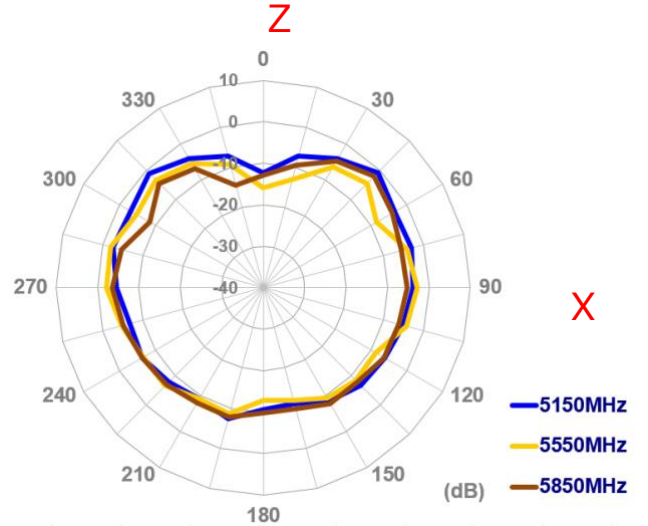
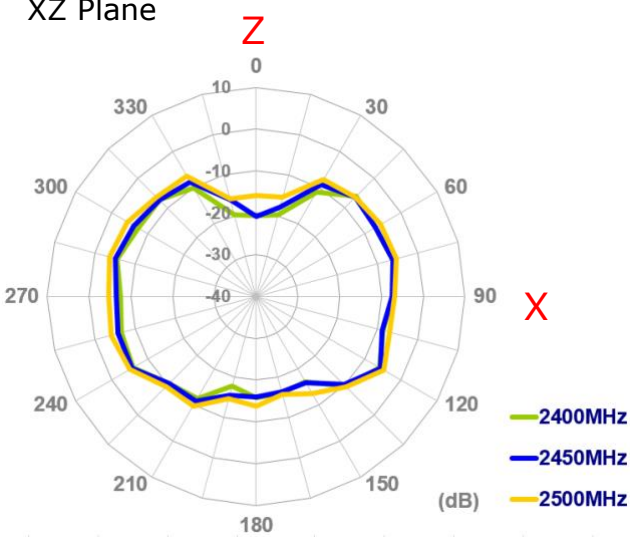

YZ Plane

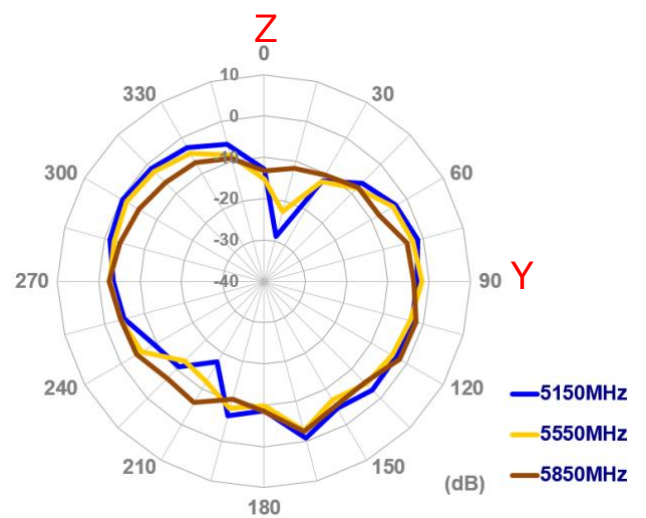
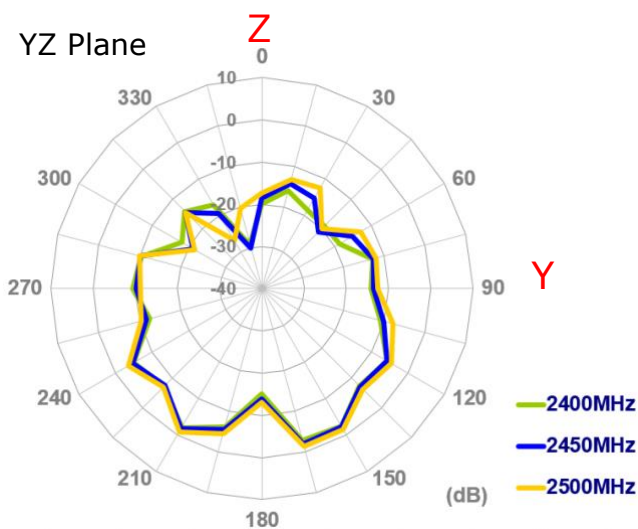

4.8 2D Radiation Pattern (Bent position with 30*30cm ground plane center)

XY Plane **X**

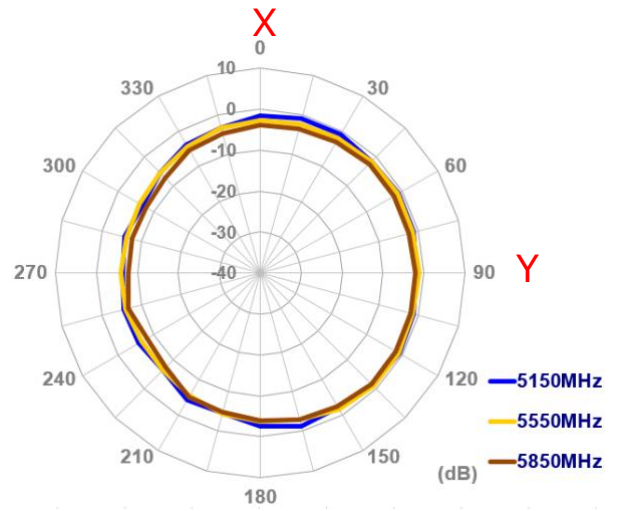
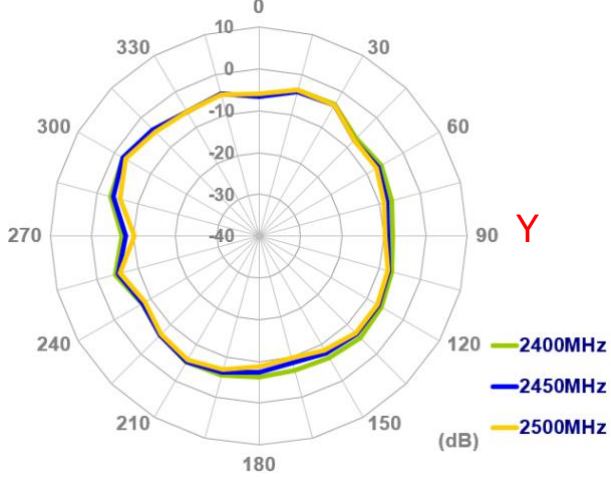

XZ Plane **Z**

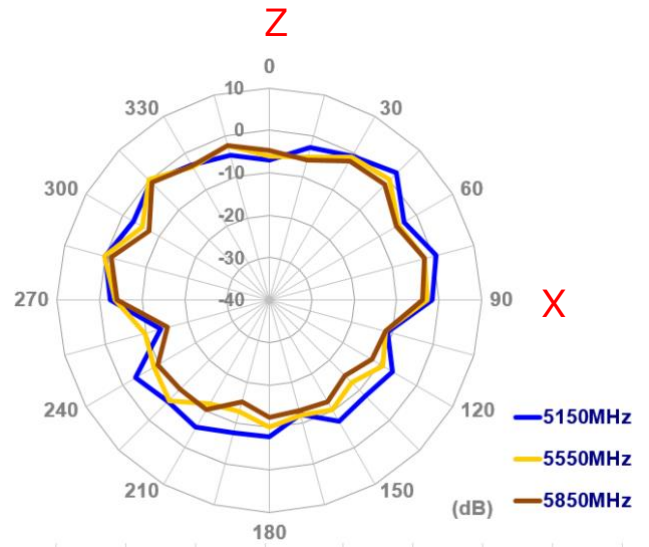
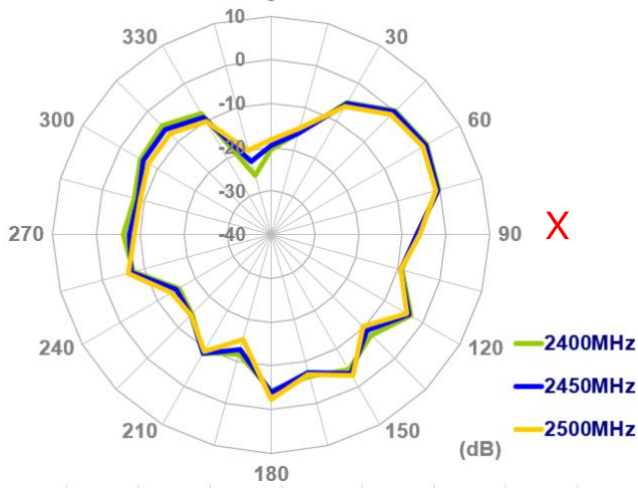

YZ Plane **Z**

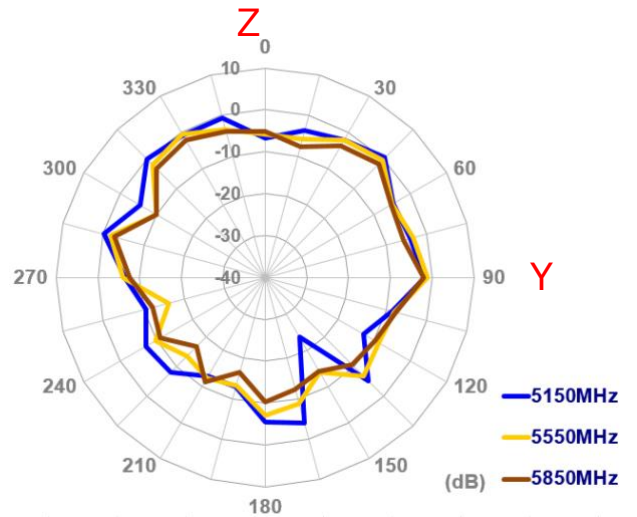
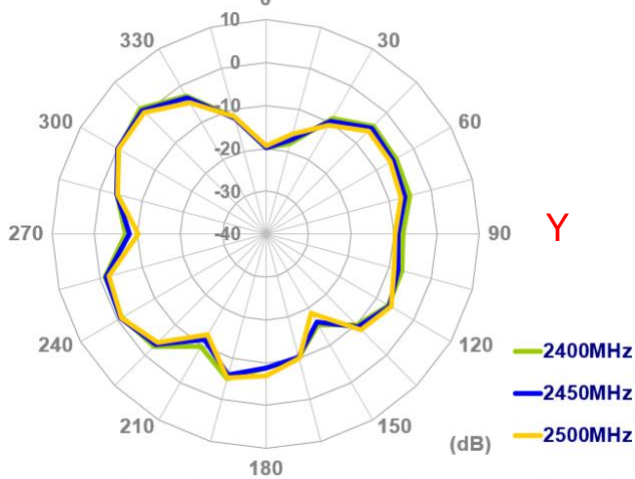

4.9 3D Radiation Pattern (Straight position in free space)

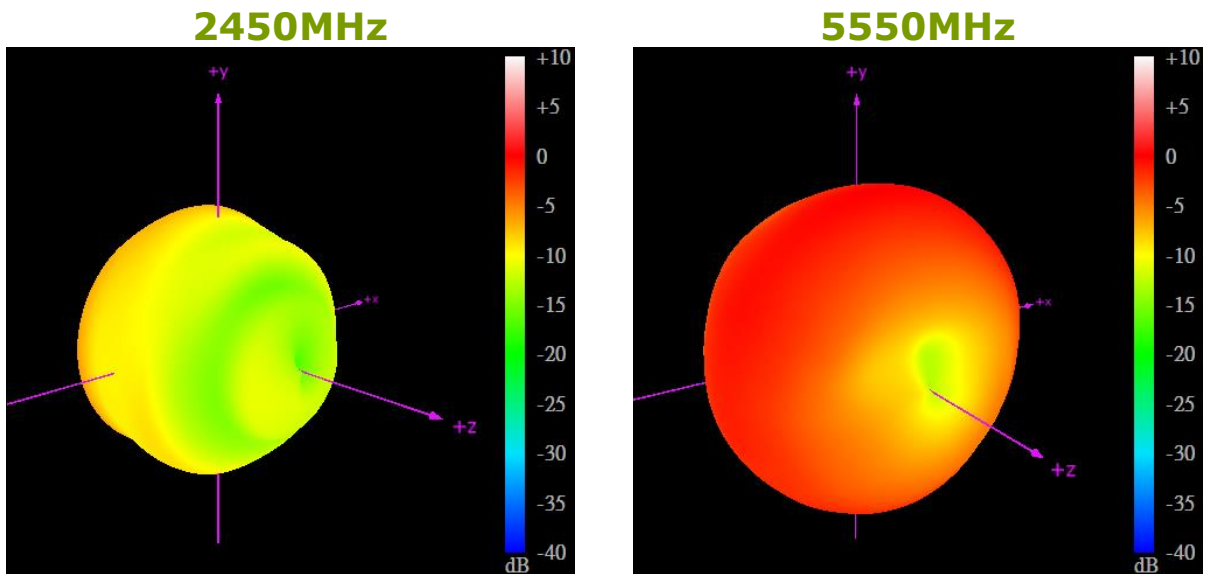

4.10 3D Radiation Pattern (Straight position with 15x9cm ground plane)

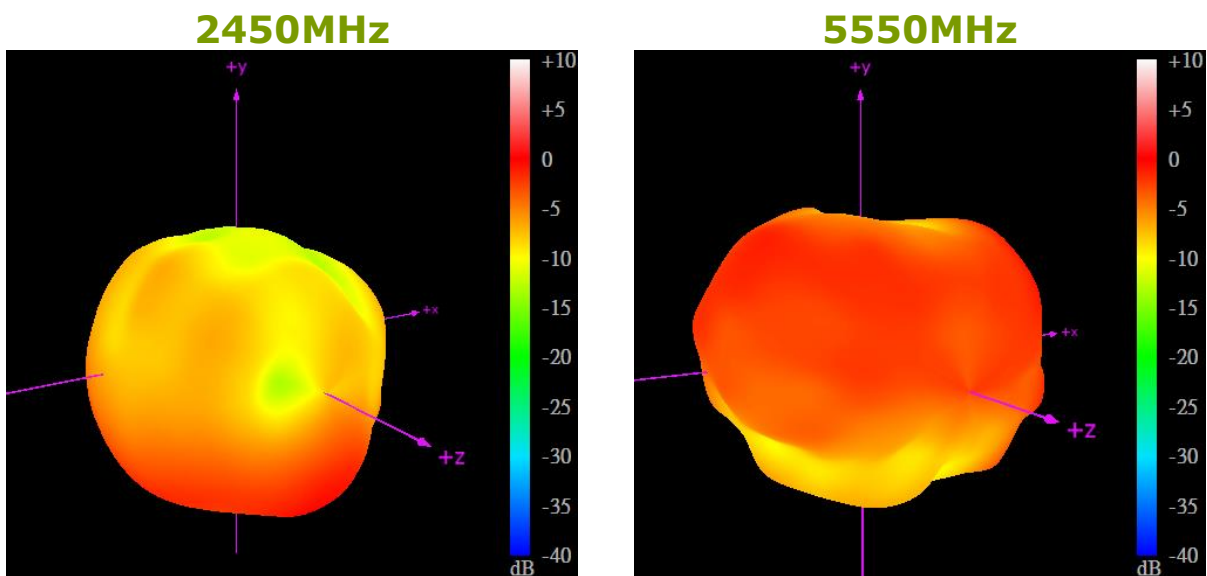

4.11 3D Radiation Pattern (Straight position with 30x30cm ground plane edge)

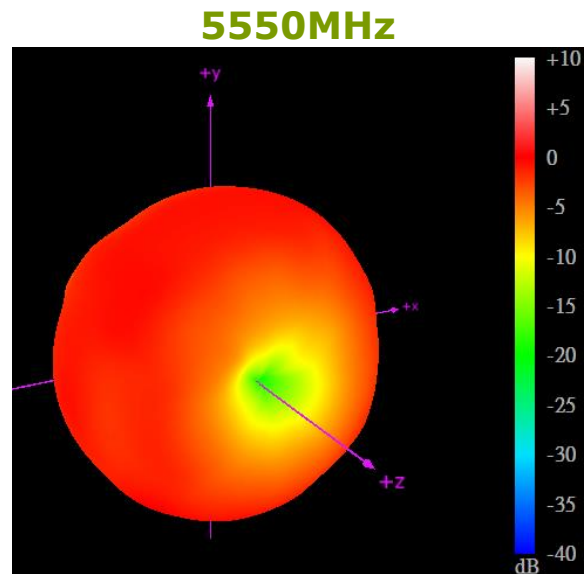
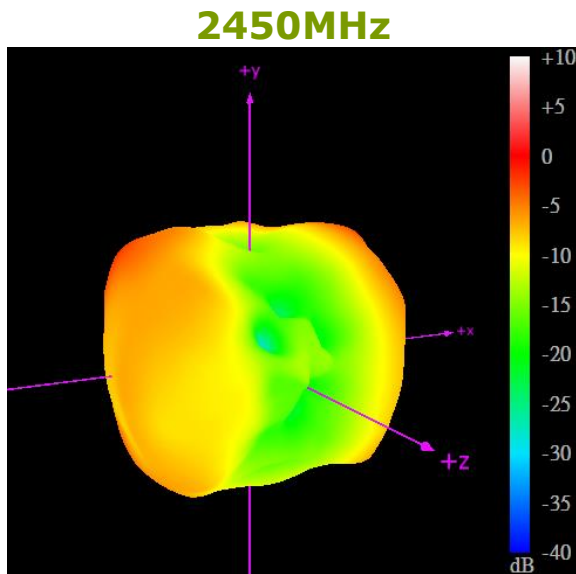

4.12 3D Radiation Pattern (Straight position with 30x30cm ground plane center)

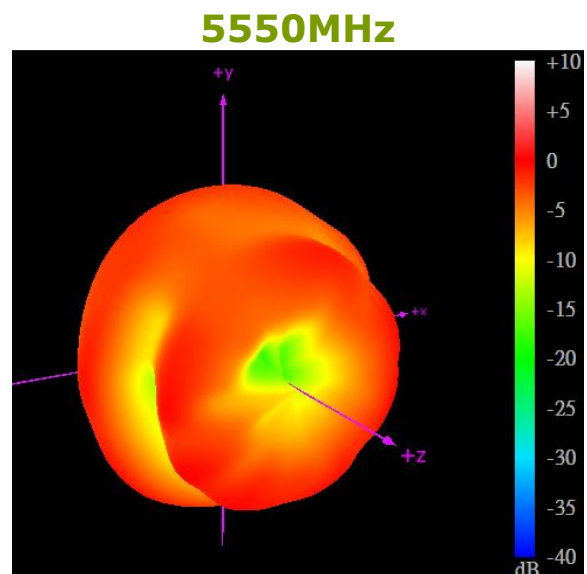
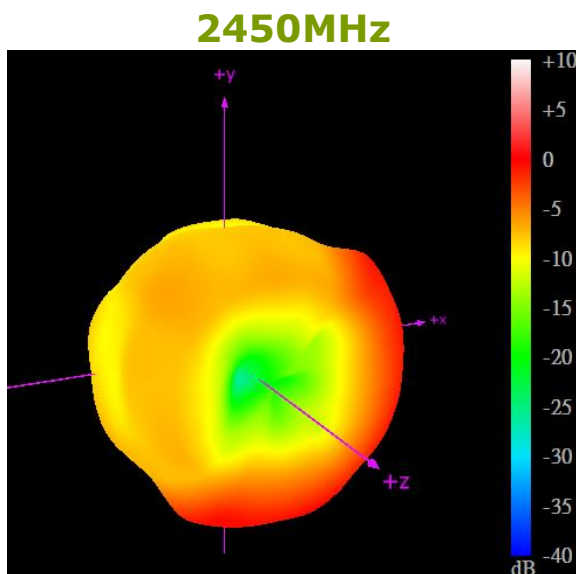

4.13 3D Radiation Pattern (Bent position in free space)

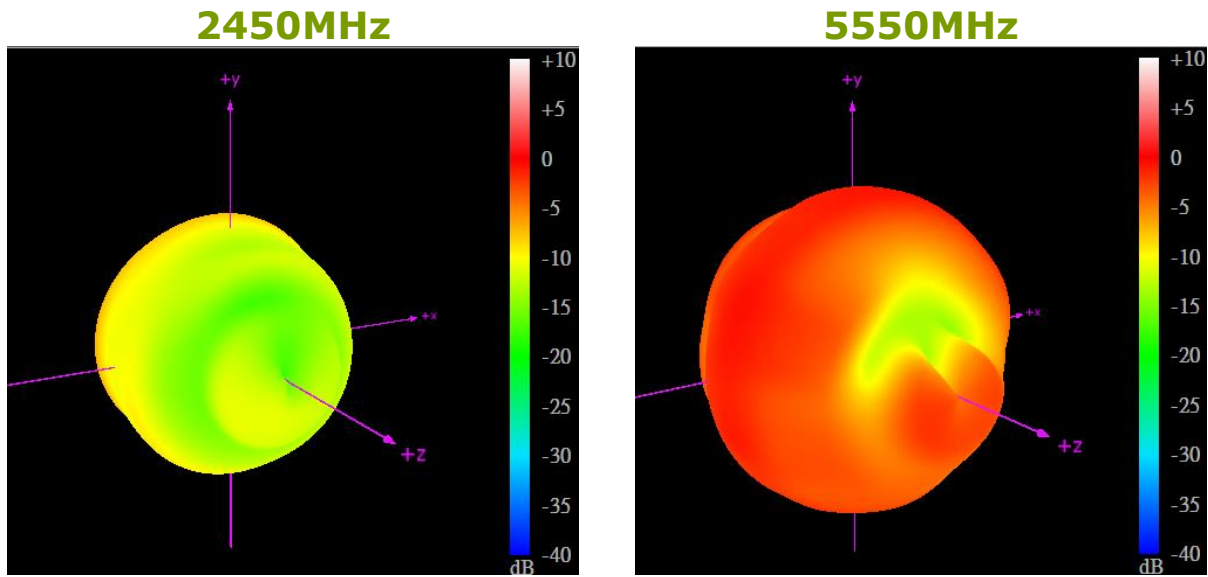

4.14 3D Radiation Pattern (Bent position with 15x9cm ground plane)

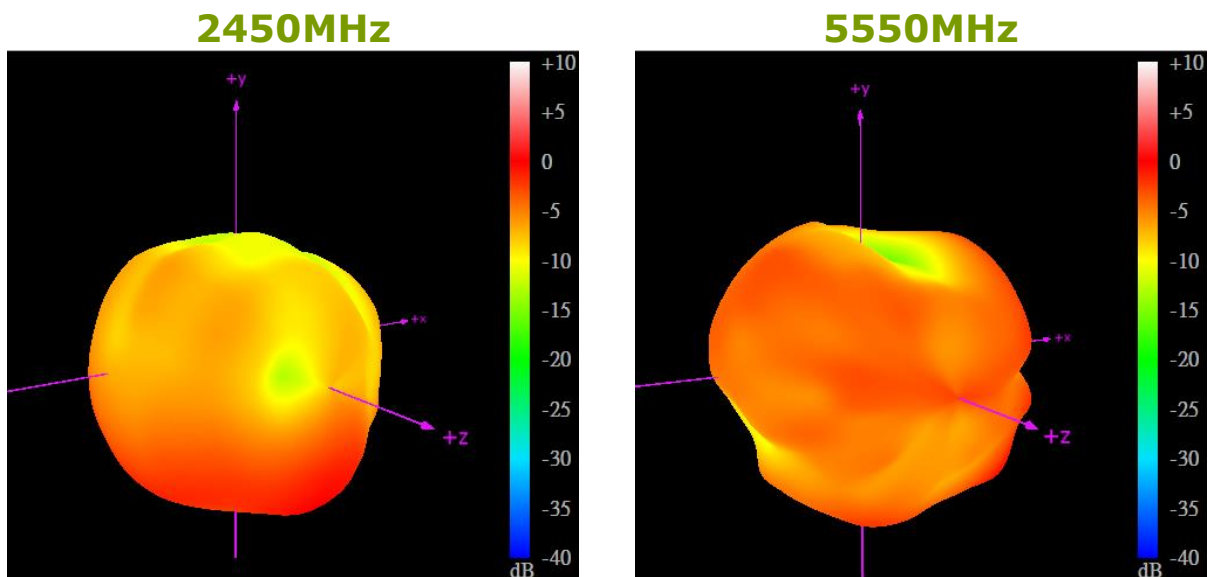

4.15 3D Radiation Pattern (Bent position with 30x30cm ground plane edge)

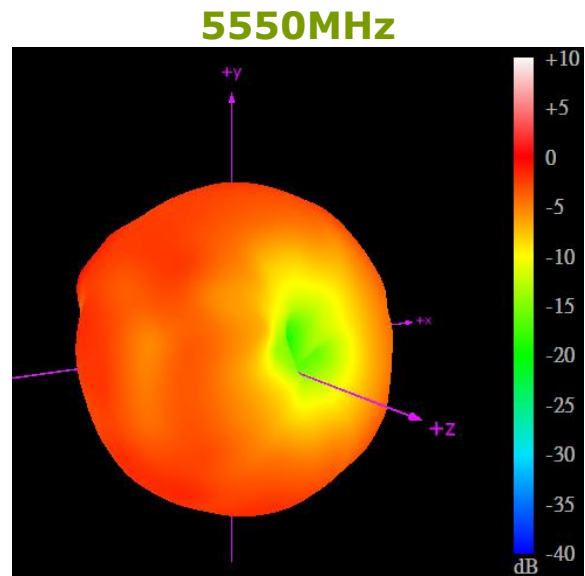
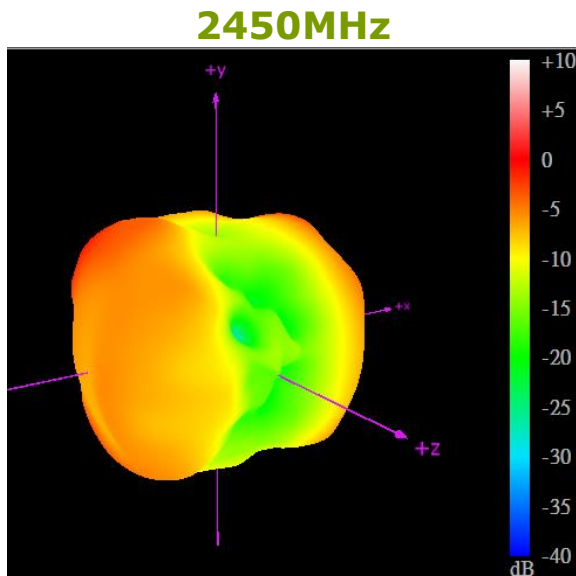

4.16 3D Radiation Pattern (Bent position with 30x30cm ground plane center)

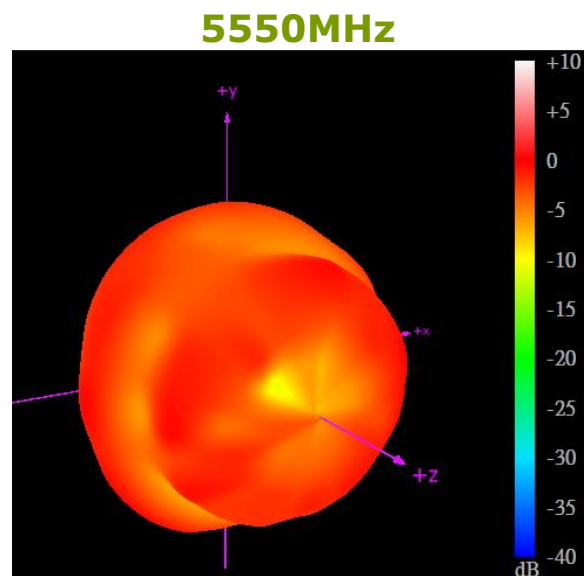
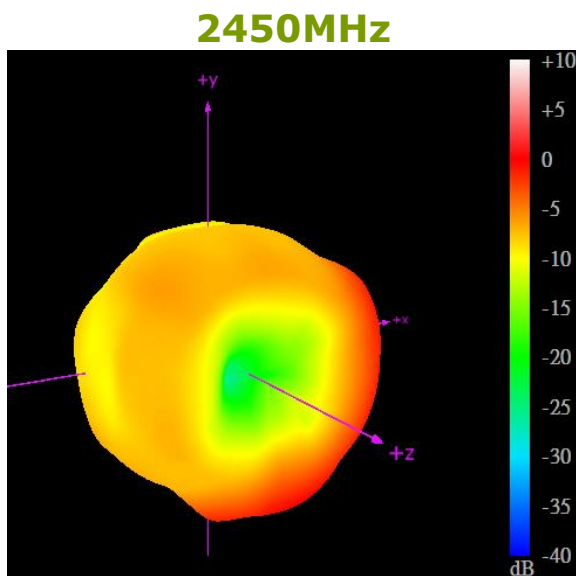

5. Mechanical Drawing (Unit:mm)

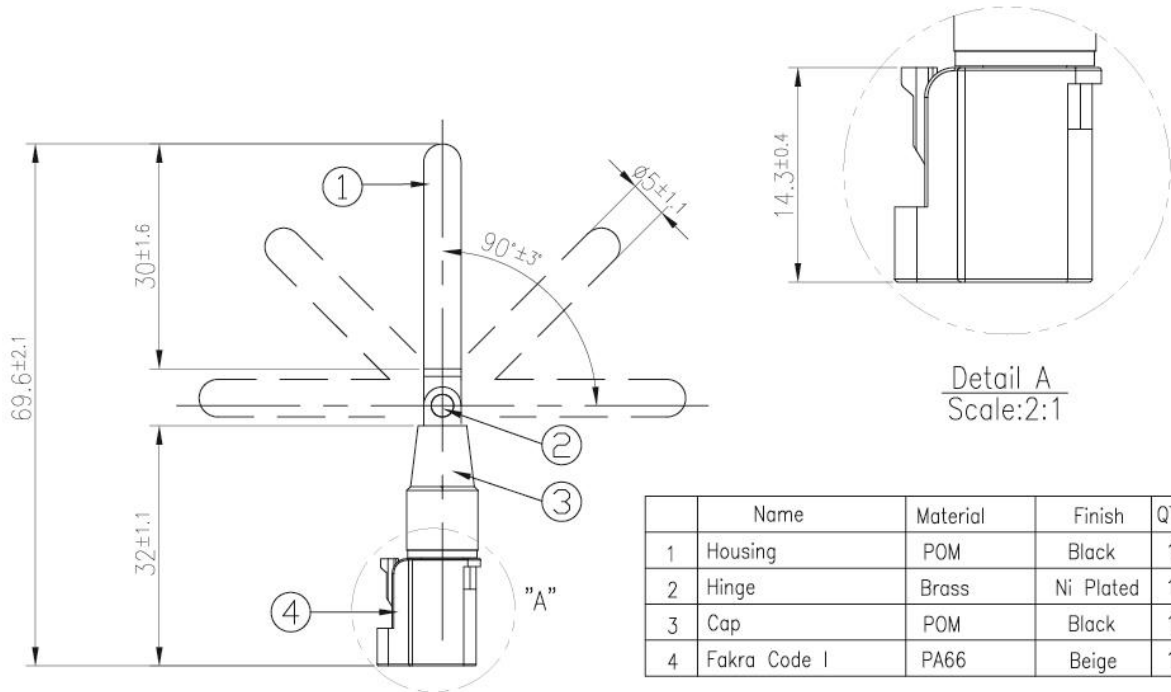

6. Packaging

1pc GW.05.0E23 per small PE bag
 Bag Dimensions - 86*52 mm
 Weight - 8.5g

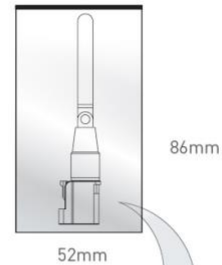

100pcs GW.05.0E23 per large PE bag
 Bag Dimensions - 280*180 mm
 Weight - 0.85Kg

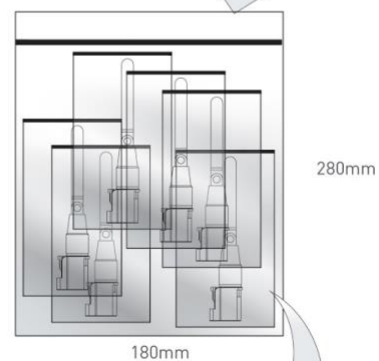

1000pcs GW.05.0E23 per carton
 Carton Dimensions - 360*310*160mm
 Weight - 9Kg

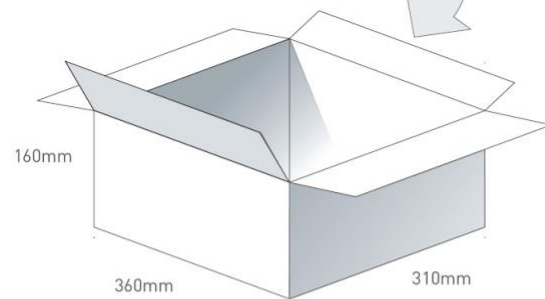

Pallet Dimensions 1200mm*1000mm*1480mm
 72 Cartons per Pallet
 9 Cartons per layer
 8 Layers

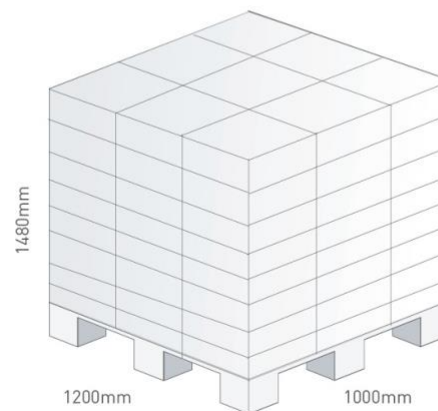

Taoglas makes no warranties based on the accuracy or completeness of the contents of this document and reserves the right to make changes to specifications and product descriptions at any time without notice. Taoglas reserves all rights to this document and the information contained herein.

Reproduction, use or disclosure to third parties without express permission is strictly prohibited.

© Taoglas

Компания «Океан Электроники» предлагает заключение долгосрочных отношений при поставках импортных электронных компонентов на взаимовыгодных условиях!

Наши преимущества:

- Поставка оригинальных импортных электронных компонентов напрямую с производств Америки, Европы и Азии, а так же с крупнейших складов мира;
- Широкая линейка поставок активных и пассивных импортных электронных компонентов (более 30 млн. наименований);
- Поставка сложных, дефицитных, либо снятых с производства позиций;
- Оперативные сроки поставки под заказ (от 5 рабочих дней);
- Экспресс доставка в любую точку России;
- Помощь Конструкторского Отдела и консультации квалифицированных инженеров;
- Техническая поддержка проекта, помощь в подборе аналогов, поставка прототипов;
- Поставка электронных компонентов под контролем ВП;
- Система менеджмента качества сертифицирована по Международному стандарту ISO 9001;
- При необходимости вся продукция военного и аэрокосмического назначения проходит испытания и сертификацию в лаборатории (по согласованию с заказчиком);
- Поставка специализированных компонентов военного и аэрокосмического уровня качества (Xilinx, Altera, Analog Devices, Intersil, Interpoint, Microsemi, Actel, Aeroflex, Peregrine, VPT, Syfer, Eurofarad, Texas Instruments, MS Kennedy, Miteq, Cobham, E2V, MA-COM, Hittite, Mini-Circuits, General Dynamics и др.);

Компания «Океан Электроники» является официальным дистрибьютором и эксклюзивным представителем в России одного из крупнейших производителей разъемов военного и аэрокосмического назначения «JONHON», а так же официальным дистрибьютором и эксклюзивным представителем в России производителя высокотехнологичных и надежных решений для передачи СВЧ сигналов «FORSTAR».



JONHON

«JONHON» (основан в 1970 г.)

Разъемы специального, военного и аэрокосмического назначения:

(Применяются в военной, авиационной, аэрокосмической, морской, железнодорожной, горно- и нефтедобывающей отраслях промышленности)

«FORSTAR» (основан в 1998 г.)

ВЧ соединители, коаксиальные кабели, кабельные сборки и микроволновые компоненты:

(Применяются в телекоммуникациях гражданского и специального назначения, в средствах связи, РЛС, а так же военной, авиационной и аэрокосмической отраслях промышленности).



Телефон: 8 (812) 309-75-97 (многоканальный)

Факс: 8 (812) 320-03-32

Электронная почта: ocean@oceanchips.ru

Web: <http://oceanchips.ru/>

Адрес: 198099, г. Санкт-Петербург, ул. Калинина, д. 2, корп. 4, лит. А