

# MAX803/MAX809/ MAX810

## 3-Pin Microprocessor Reset Circuits

### General Description

The MAX803/MAX809/MAX810 are microprocessor ( $\mu\text{P}$ ) supervisory circuits used to monitor the power supplies in  $\mu\text{P}$  and digital systems. They provide excellent circuit reliability and low cost by eliminating external components and adjustments when used with +5V, +3.3V, +3.0V, or +2.5V powered circuits.

These circuits perform a single function: they assert a reset signal whenever the  $V_{\text{CC}}$  supply voltage declines below a preset threshold, keeping it asserted for at least 140ms after  $V_{\text{CC}}$  has risen above the reset threshold. Reset thresholds suitable for operation with a variety of supply voltages are available.

The MAX803 has an open-drain output stage, while the MAX809/MAX810 have push-pull outputs. The MAX803's open-drain RESETE output requires a pullup resistor that can be connected to a voltage higher than  $V_{\text{CC}}$ . The MAX803/MAX809 have an active-low RESETE output, while the MAX810 has an active-high RESETE output. The reset comparator is designed to ignore fast transients on  $V_{\text{CC}}$ , and the outputs are guaranteed to be in the correct logic state for  $V_{\text{CC}}$  down to 1V.

Low supply current makes the MAX803/MAX809/MAX810 ideal for use in portable equipment. The MAX803 is available in a 3-pin SC70 package, and the MAX809/MAX810 are available in 3-pin SC70 or SOT23 packages.

### Applications

- Computers
- Controllers
- Intelligent Instruments
- Critical  $\mu\text{P}$  and  $\mu\text{C}$  Power Monitoring
- Portable/Battery-Powered Equipment
- Automotive

### Benefits and Features

- Precision Monitoring of +2.5V, +3V, +3.3V, and +5V Power-Supply Voltages
- Fully Specified Over Temperature
- Available in Three Output Configurations
  - Open-Drain RESETE Output (MAX803)
  - Push-Pull RESETE Output (MAX809)
  - Push-Pull RESETE Output (MAX810)
- 140ms (min) Power-On-Reset Pulse Width
- 12 $\mu\text{A}$  Supply Current
- Guaranteed Reset Valid to  $V_{\text{CC}} = +1\text{V}$
- Power Supply Transient Immunity
- No External Components
- 3-Pin SC70 and SOT23 Packages
- AEC-Q100 Qualified. Refer to [Ordering Information](#) for Specific IV Versions.

[Selector Guide](#) and [Ordering Information](#) appear at end of data sheet.

### Typical Operating Circuit

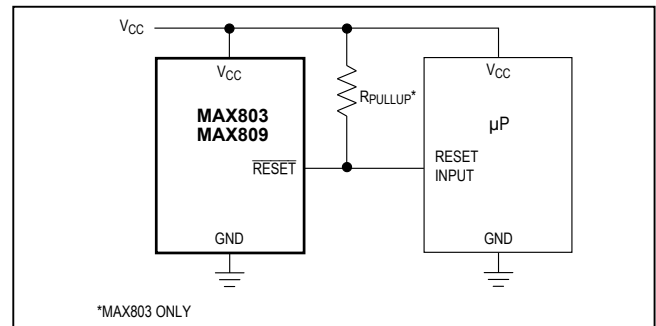

### Absolute Maximum Ratings

Terminal Voltage (with respect to GND)

$V_{CC}$ .....	-0.3V to +6.0V
RESET, $\overline{\text{RESET}}$ (push-pull).....	-0.3V to ( $V_{CC} + 0.3V$ )
$\overline{\text{RESET}}$ (open drain).....	-0.3V to +6.0V
Input Current, $V_{CC}$ .....	20mA
Output Current, RESET, $\overline{\text{RESET}}$ .....	20mA
Rate of Rise, $V_{CC}$ .....	100V/ $\mu$ s

Continuous Power Dissipation ( $T_A = +70^\circ\text{C}$ )

3-Pin SC70 (derate 2.17mW/ $^\circ\text{C}$ above +70 $^\circ\text{C}$ ).....	174mW
3-Pin SOT23 (derate 4mW/ $^\circ\text{C}$ above +70 $^\circ\text{C}$ ).....	320mW

Operating Temperature Range

3-Pin SC70.....	-40 $^\circ\text{C}$ to +125 $^\circ\text{C}$
3-Pin SOT23.....	-40 $^\circ\text{C}$ to +105 $^\circ\text{C}$

Storage Temperature Range.....-65 $^\circ\text{C}$  to +150 $^\circ\text{C}$

Lead Temperature (soldering, 10s).....+300 $^\circ\text{C}$

Soldering Temperature (reflow).....+260 $^\circ\text{C}$

Stresses beyond those listed under "Absolute Maximum Ratings" may cause permanent damage to the device. These are stress ratings only, and functional operation of the device at these or any other conditions beyond those indicated in the operational sections of the specifications is not implied. Exposure to absolute maximum rating conditions for extended periods may affect device reliability.

### Electrical Characteristics

( $V_{CC}$  = full range,  $T_A = -40^\circ\text{C}$  to +105 $^\circ\text{C}$  (SOT23) or  $T_A = -40^\circ\text{C}$  to +125 $^\circ\text{C}$  (SC70), unless otherwise noted. Typical values are at  $T_A = +25^\circ\text{C}$ ,  $V_{CC} = 5V$  for L/M/J versions,  $V_{CC} = 3.3V$  for T/S versions,  $V_{CC} = 3V$  for R version, and  $V_{CC} = 2.5V$  for Z version.) (Note 1)

PARAMETER	SYMBOL	CONDITIONS	MIN	TYP	MAX	UNITS	
$V_{CC}$ Range		$T_A = 0^\circ\text{C}$ to +70 $^\circ\text{C}$	1.0		5.5	V	
		$T_A = -40^\circ\text{C}$ to +105 $^\circ\text{C}$ (MAX8__EUR)	1.2		5.5		
		$T_A = -40^\circ\text{C}$ to +125 $^\circ\text{C}$ (MAX8__EXR)	1.2		5.5		
Supply Current (SOT23)	$I_{CC}$	$T_A = -40^\circ\text{C}$ to +85 $^\circ\text{C}$	$V_{CC} < 5.5V$ , MAX8__L/M	24	60	$\mu\text{A}$	
			$V_{CC} < 3.6V$ , MAX8__R/S/T/Z	17	50		
		$T_A = +85^\circ\text{C}$ to +105 $^\circ\text{C}$	$V_{CC} < 5.5V$ , MAX8__L/M		100		
			$V_{CC} < 3.6V$ , MAX8__R/S/T/Z		100		
Supply Current (SC70)	$I_{CC}$	$T_A = -40^\circ\text{C}$ to +85 $^\circ\text{C}$	$V_{CC} < 5.5V$ , MAX8__L/M	24	35	$\mu\text{A}$	
			$V_{CC} < 3.6V$ , MAX8__R/S/T/Z	17	30		
		$T_A = +85^\circ\text{C}$ to +125 $^\circ\text{C}$	$V_{CC} < 5.5V$ , MAX8__L/M		60		
			$V_{CC} < 3.6V$ , MAX8__R/S/T/Z		60		
Reset Threshold (SOT only)	$V_{TH}$	MAX8__L	$T_A = +25^\circ\text{C}$	4.56	4.63	4.70	V
			$T_A = -40^\circ\text{C}$ to +85 $^\circ\text{C}$	4.50		4.75	
			$T_A = -40^\circ\text{C}$ to +125 $^\circ\text{C}$	4.40		4.86	
		MAX8__M	$T_A = +25^\circ\text{C}$	4.31	4.38	4.45	
			$T_A = -40^\circ\text{C}$ to +85 $^\circ\text{C}$	4.25		4.50	
			$T_A = -40^\circ\text{C}$ to +125 $^\circ\text{C}$	4.16		4.56	
		MAX809J (SOT only)	$T_A = +25^\circ\text{C}$	3.93	4.00	4.06	
			$T_A = -40^\circ\text{C}$ to +85 $^\circ\text{C}$	3.89		4.10	
			$T_A = -40^\circ\text{C}$ to +125 $^\circ\text{C}$	3.80		4.20	
		MAX8__T	$T_A = +25^\circ\text{C}$	3.04	3.08	3.11	
			$T_A = -40^\circ\text{C}$ to +85 $^\circ\text{C}$	3.00		3.15	
			$T_A = -40^\circ\text{C}$ to +125 $^\circ\text{C}$	2.92		3.23	
		MAX8__S	$T_A = +25^\circ\text{C}$	2.89	2.93	2.96	
			$T_A = -40^\circ\text{C}$ to +85 $^\circ\text{C}$	2.85		3.00	
			$T_A = -40^\circ\text{C}$ to +125 $^\circ\text{C}$	2.78		3.08	
		MAX8__R	$T_A = +25^\circ\text{C}$	2.59	2.63	2.66	
			$T_A = -40^\circ\text{C}$ to +85 $^\circ\text{C}$	2.55		2.70	
			$T_A = -40^\circ\text{C}$ to +125 $^\circ\text{C}$	2.50		2.76	

**Electrical Characteristics (continued)**

(V<sub>CC</sub> = full range, T<sub>A</sub> = -40°C to +105°C (SOT23) or T<sub>A</sub> = -40°C to +125°C (SC70), unless otherwise noted. Typical values are at T<sub>A</sub> = +25°C, V<sub>CC</sub> = 5V for L/M/J versions, V<sub>CC</sub> = 3.3V for T/S versions, V<sub>CC</sub> = 3V for R version, and V<sub>CC</sub> = 2.5V for Z version.) (Note 1)

PARAMETER	SYMBOL	CONDITIONS	MIN	TYP	MAX	UNITS	
Reset Threshold (SC70 only)	V <sub>TH</sub>	MAX8__L	T <sub>A</sub> = +25°C	4.56	4.63	4.70	V
			T <sub>A</sub> = -40°C to +85°C	4.50		4.75	
			T <sub>A</sub> = -40°C to +125°C	4.44		4.82	
		MAX8__M	T <sub>A</sub> = +25°C	4.31	4.38	4.45	
			T <sub>A</sub> = -40°C to +85°C	4.25		4.50	
			T <sub>A</sub> = -40°C to +125°C	4.20		4.56	
		MAX8__T	T <sub>A</sub> = +25°C	3.04	3.08	3.11	
			T <sub>A</sub> = -40°C to +85°C	3.00		3.15	
			T <sub>A</sub> = -40°C to +125°C	2.95		3.21	
		MAX8__S	T <sub>A</sub> = +25°C	2.89	2.93	2.96	
			T <sub>A</sub> = -40°C to +85°C	2.85		3.00	
			T <sub>A</sub> = -40°C to +125°C	2.81		3.05	
		MAX8__R	T <sub>A</sub> = +25°C	2.59	2.63	2.66	
			T <sub>A</sub> = -40°C to +85°C	2.55		2.70	
			T <sub>A</sub> = -40°C to +125°C	2.52		2.74	
		MAX8__Z (SC70 only)	T <sub>A</sub> = +25°C	2.28	2.32	2.35	
			T <sub>A</sub> = -40°C to +85°C	2.25		2.38	
			T <sub>A</sub> = -40°C to +125°C	2.22		2.42	
Reset Threshold Tempco			30			ppm/°C	
V <sub>CC</sub> to Reset Delay (Note 2)		V <sub>CC</sub> = V <sub>TH</sub> to (V <sub>TH</sub> - 100mV)		20		μs	
Reset Active Timeout Period (SOT23)		T <sub>A</sub> = -40°C to +85°C	140	240	560	ms	
		T <sub>A</sub> = +85°C to +105°C	100		840		
Reset Active Timeout Period (SC70)		T <sub>A</sub> = -40°C to +85°C	140	240	460	ms	
		T <sub>A</sub> = +85°C to +125°C	100		840		
RESET Output Voltage Low (push-pull active low and open-drain active low, MAX803 and MAX809)	V <sub>OL</sub>	V <sub>CC</sub> = V <sub>TH</sub> (min), I <sub>SINK</sub> = 1.2mA, MAX803R/S/T/Z, MAX809R/S/T/Z			0.3	V	
		V <sub>CC</sub> = V <sub>TH</sub> (min), I <sub>SINK</sub> = 3.2mA, MAX803L/M, MAX809J/L/M			0.4		
		V <sub>CC</sub> > 1.0V, I <sub>SINK</sub> = 50μA			0.3		
RESET Output Voltage High (push-pull active low MAX809)	V <sub>OH</sub>	V <sub>CC</sub> > V <sub>TH</sub> (max), I <sub>SOURCE</sub> = 500μA, MAX803R/S/T/Z, MAX809R/S/T/Z	0.8V <sub>CC</sub>			V	
		V <sub>CC</sub> > V <sub>TH</sub> (max), I <sub>SOURCE</sub> = 800μA, MAX803L/M, MAX809J/L/M	V <sub>CC</sub> - 1.5				
RESET Output Voltage Low (push-pull active high, MAX810)	V <sub>OL</sub>	V <sub>CC</sub> = V <sub>TH</sub> (max), I <sub>SINK</sub> = 1.2mA, MAX810R/S/T/Z			0.3	V	
		V <sub>CC</sub> = V <sub>TH</sub> (max), I <sub>SINK</sub> = 3.2mA, MAX810L/M			0.4		

**Electrical Characteristics (continued)**

( $V_{CC}$  = full range,  $T_A$  =  $-40^{\circ}\text{C}$  to  $+105^{\circ}\text{C}$  (SOT23) or  $T_A$  =  $-40^{\circ}\text{C}$  to  $+125^{\circ}\text{C}$  (SC70), unless otherwise noted. Typical values are at  $T_A$  =  $+25^{\circ}\text{C}$ ,  $V_{CC}$  = 5V for L/M/J versions,  $V_{CC}$  = 3.3V for T/S versions,  $V_{CC}$  = 3V for R version, and  $V_{CC}$  = 2.5V for Z version.) (Note 1)

PARAMETER	SYMBOL	CONDITIONS	MIN	TYP	MAX	UNITS
RESET Output Voltage High (push-pull active high, MAX810)	$V_{OH}$	$1.8\text{V} < V_{CC} < V_{TH}$ (min), $I_{SOURCE} = 150\mu\text{A}$	$0.8V_{CC}$			V
RESET Open-Drain Output Leakage Current (MAX803) (Note 3)		$V_{CC} > V_{TH}$ , RESET deasserted			1	$\mu\text{A}$

**Note 1:** Production testing done at  $T_A$  =  $+25^{\circ}\text{C}$ ; limits over temperature guaranteed by design only.

**Note 2:** RESET output for MAX803/MAX809; RESET output for MAX810.

**Note 3:** Guaranteed by design, not production tested.

**Typical Operating Characteristics**

( $V_{CC}$  = full range,  $T_A$  =  $-40^{\circ}\text{C}$  to  $+105^{\circ}\text{C}$ , unless otherwise noted. Typical values are at  $T_A$  =  $+25^{\circ}\text{C}$ ,  $V_{CC}$  = +5V for L/M/J versions,  $V_{CC}$  = +3.3V for T/S versions,  $V_{CC}$  = +3V for R version, and  $V_{CC}$  = +2.5V for Z version.)

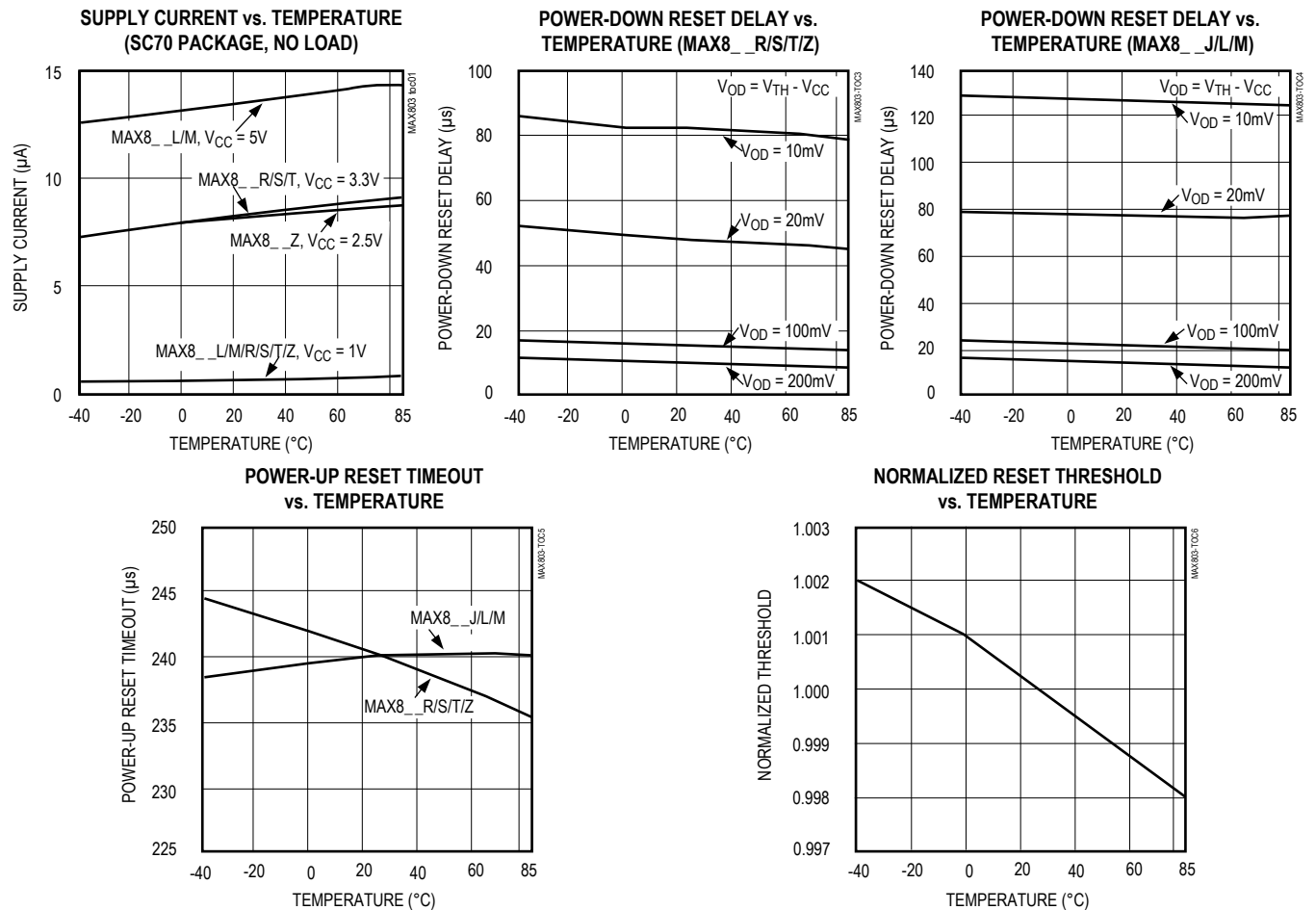

## Pin Configuration

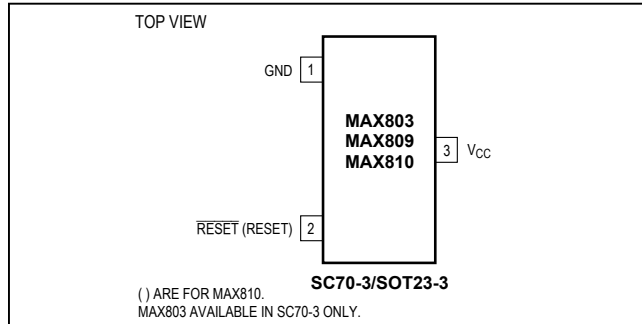

## Pin Description

PIN	NAME	FUNCTION
1	GND	Ground
2	$\overline{\text{RESET}}$ (MAX803/ MAX809)	$\overline{\text{RESET}}$ Output remains low while V <sub>CC</sub> is below the reset threshold, and for at least 140ms after V <sub>CC</sub> rises above the reset threshold.
	RESET (MAX810)	RESET Output remains high while V <sub>CC</sub> is below the reset threshold, and for at least 140ms after V <sub>CC</sub> rises above the reset threshold.
3	V <sub>CC</sub>	Supply Voltage (+5V, +3.3V, +3.0V, or +2.5V)

## Detailed Description

A microprocessor's ( $\mu\text{P}$ 's) reset input starts the  $\mu\text{P}$  in a known state. The MAX803/MAX809/MAX810 assert reset to prevent code-execution errors during power-up, power-down, or brownout conditions. They assert a reset signal whenever the V<sub>CC</sub> supply voltage declines below a preset threshold, keeping it asserted for at least 140ms after V<sub>CC</sub> has risen above the reset threshold. The MAX803 uses an open-drain output, and the MAX809/MAX810 have a push-pull output stage. Connect a pullup resistor on the MAX803's  $\overline{\text{RESET}}$  output to any supply between 0 and 6V.

## Applications Information

### Negative-Going V<sub>CC</sub> Transients

In addition to issuing a reset to the  $\mu\text{P}$  during power-up, power-down, and brownout conditions, the MAX803/MAX809/MAX810 are relatively immune to short-duration negative-going V<sub>CC</sub> transients (glitches).

Figure 1 shows typical transient duration vs. reset comparator overdrive, for which the MAX803/MAX809/MAX810 do **not** generate a reset pulse. The graph was generated using a negative-going pulse applied

to V<sub>CC</sub>, starting 0.5V above the actual reset threshold and ending below it by the magnitude indicated (reset comparator overdrive). The graph indicates the maximum pulse width a negative-going V<sub>CC</sub> transient can have without causing a reset pulse. As the magnitude of the transient increases (goes farther below the reset threshold), the maximum allowable pulse width decreases. Typically, for the MAX8\_\_L and MAX8\_\_M, a V<sub>CC</sub> transient that goes 100mV below the reset threshold and lasts 20 $\mu\text{s}$  or less will not cause a reset pulse. A 0.1 $\mu\text{F}$  bypass capacitor mounted as close as possible to the V<sub>CC</sub> pin provides additional transient immunity.

### Ensuring a Valid Reset Output Down to V<sub>CC</sub> = 0V

When V<sub>CC</sub> falls below 1V, the MAX809  $\overline{\text{RESET}}$  output no longer sinks current—it becomes an open circuit.

Therefore, high-impedance CMOS logic inputs connected to  $\overline{\text{RESET}}$  can drift to undetermined voltages. This presents no problem in most applications since most  $\mu\text{P}$  and other circuitry is inoperative with V<sub>CC</sub> below 1V. However, in applications where  $\overline{\text{RESET}}$  must be valid down to 0V, adding a pull-down resistor to  $\overline{\text{RESET}}$  causes any stray leakage currents to flow to ground, holding  $\overline{\text{RESET}}$  low (Figure 2). R1's value is not critical; 100k $\Omega$  is large enough not to load  $\overline{\text{RESET}}$  and small enough to pull  $\overline{\text{RESET}}$  to ground.

A 100k $\Omega$  pullup resistor to V<sub>CC</sub> is also recommended for the MAX810 if RESET is required to remain valid for V<sub>CC</sub> < 1V.

### Interfacing to $\mu\text{P}$ s with Bidirectional Reset Pins

Since the  $\overline{\text{RESET}}$  output on the MAX803 is open drain, this device interfaces easily with  $\mu\text{P}$ s that have bidirectional reset pins, such as the Motorola 68HC11. Connecting the  $\mu\text{P}$  supervisor's  $\overline{\text{RESET}}$  output directly to the  $\mu\text{C}$ 's  $\overline{\text{RESET}}$  pin with a single pullup resistor allows either device to assert reset (Figure 3).

### MAX803 Open-Drain $\overline{\text{RESET}}$ Output Allows Use with Multiple Supplies

Generally, the pullup connected to the MAX803 will connect to the supply voltage that is being monitored at the IC's V<sub>CC</sub> pin. However, some systems may use the open-drain output to level-shift from the monitored supply to reset circuitry powered by some other supply (Figure 4). Note that as the MAX803's V<sub>CC</sub> decreases below 1V, so does the IC's ability to sink current at  $\overline{\text{RESET}}$ . Also, with any pullup,  $\overline{\text{RESET}}$  will be pulled high as V<sub>CC</sub> decays toward 0. The voltage where this occurs depends on the pullup resistor value and the voltage to which it is connected.

**Benefits of Highly Accurate Reset Threshold**

Most  $\mu$ P supervisor ICs have reset-threshold voltages between 5% and 10% below the value of nominal supply voltages. This ensures a reset will **not** occur within 5% of the nominal supply, but **will** occur when the supply is 10% below nominal.

When using ICs rated at only the nominal supply  $\pm 5\%$ , this leaves a zone of uncertainty where the supply is between 5% and 10% low, and where the reset may or may not be asserted.

The MAX8\_L/T/Z use highly accurate circuitry to ensure that reset is asserted close to the 5% limit, and long before the supply has declined to 10% below nominal.

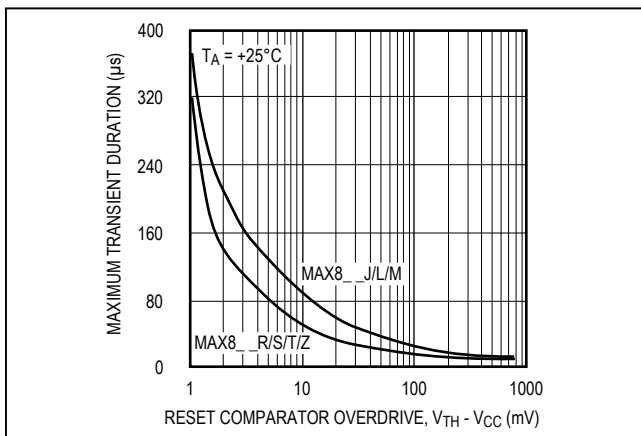

Figure 1. Maximum Transient Duration Without Causing a Reset Pulse vs. Reset Comparator Overdrive

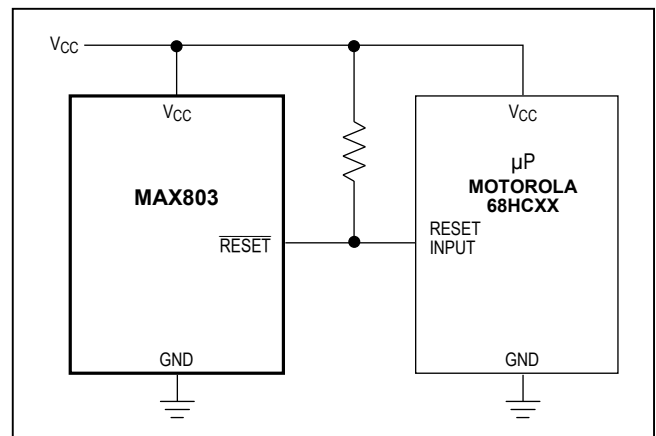

Figure 3. Interfacing to  $\mu$ Ps with Bidirectional Reset I/O

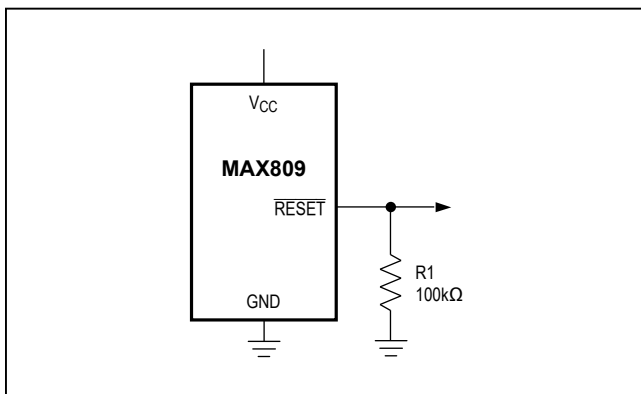

Figure 2.  $\overline{\text{RESET}}$  Valid to  $V_{CC} = \text{Ground}$  Circuit

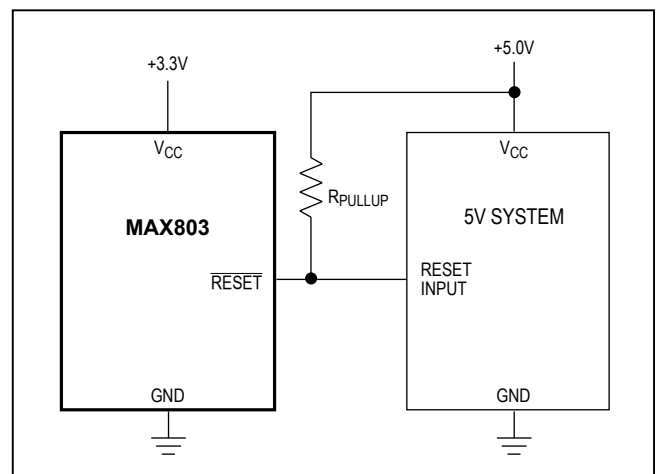

Figure 4. MAX803 Open-Drain  $\overline{\text{RESET}}$  Output Allows Use with Multiple Supplies

## Selector Guide

PART/SUFFIX	RESET THRESHOLD (V)	OUTPUT TYPE
MAX803L	4.63	Open-Drain $\overline{\text{RESET}}$
MAX803M	4.38	Open-Drain $\overline{\text{RESET}}$
MAX803T	3.08	Open-Drain $\overline{\text{RESET}}$
MAX803S	2.93	Open-Drain $\overline{\text{RESET}}$
MAX803R	2.63	Open-Drain $\overline{\text{RESET}}$
MAX803Z	2.32	Open-Drain $\overline{\text{RESET}}$
MAX809L	4.63	Push-Pull $\overline{\text{RESET}}$
MAX809M	4.38	Push-Pull $\overline{\text{RESET}}$
MAX809J	4.00	Push-Pull $\overline{\text{RESET}}$
MAX809T	3.08	Push-Pull $\overline{\text{RESET}}$
MAX809S	2.93	Push-Pull $\overline{\text{RESET}}$
MAX809R	2.63	Push-Pull $\overline{\text{RESET}}$
MAX809Z	2.32	Push-Pull $\overline{\text{RESET}}$
MAX810L	4.63	Push-Pull RESET
MAX810M	4.38	Push-Pull RESET
MAX810T	3.08	Push-Pull RESET
MAX810S	2.93	Push-Pull RESET
MAX810R	2.63	Push-Pull RESET
MAX810Z	2.32	Push-Pull RESET

## Ordering Information

PART	TEMP RANGE	PIN-PACKAGE
<b>MAX803</b> _EXR-T	-40°C to +125°C	3 SC70
MAX803_EXR+T	-40°C to +125°C	3 SC70
MAX803_EXR/V+	-40°C to +125°C	3 SC70
MAX803_EXR/V+T	-40°C to +125°C	3 SC70
MAX803LEXR/V+	-40°C to +125°C	3 SC70
MAX803MEXR/V+T	-40°C to +125°C	3 SC70
MAX803SEXR/V+T	-40°C to +125°C	3 SC70
MAX803TEXR/V+T	-40°C to +125°C	3 SC70
<b>MAX809</b> _EXR-T	-40°C to +125°C	3 SC70
MAX809_EXR+T	-40°C to +125°C	3 SC70
MAX809_EUR-T	-40°C to +105°C	3 SOT23
MAX809_EUR+T	-40°C to +105°C	3 SOT23
<b>MAX810</b> _EXR+T	-40°C to +125°C	3 SC70
MAX810_EUR+T	-40°C to +105°C	3 SOT23

**Note:** These parts are offered in 2.5k reels, and must be ordered in 2.5k increments. Insert the desired suffix letter from the Selector Guide into the blank to complete the part number. All versions of these products may not be available at the time of announcement. Contact factory for availability.

Some devices are available in both leaded and lead-free packaging.

+ Denotes a lead(Pb)-free/RoHS-compliant package.

/V denotes an automotive qualified part.

T = Tape and reel.

## Chip Information

TRANSISTOR COUNT: 275 (SOT23)  
380 (SC70)

## Package Information

For the latest package outline information and land patterns (footprints), go to [www.maximintegrated.com/packages](http://www.maximintegrated.com/packages). Note that a "+", "#", or "-" in the package code indicates RoHS status only. Package drawings may show a different suffix character, but the drawing pertains to the package regardless of RoHS status.

PACKAGE TYPE	PACKAGE CODE	DOCUMENT NO.
3 SC70	X3+2, X3-2	<a href="#">21-0075</a>
3 SOT23	U3+1, U3-1	<a href="#">21-0051</a>

## Revision History

REVISION NUMBER	REVISION DATE	DESCRIPTION	PAGES CHANGED
0	12/94	Initial release.	—
7	2/10	Updated <i>Ordering Information</i> , added lead-free note, and added soldering temperature in the <i>Absolute Maximum Ratings</i>	1, 2
8	12/12	Added MAX803_EXR/V+ to <i>Ordering Information</i>	1
9	6/15	Added MAX803_EXR/V+ to <i>Ordering Information</i> , moved <i>Ordering Information</i> , <i>Pin Configuration</i> , and <i>Selector Guide</i> to end of data sheet, and rebranded data sheet	1–8
10	12/15	Added lead-free package code information and removed top mark information from <i>Selector Guide</i>	7
11	10/17	Added AEC qualification statement to <i>Benefits and Features</i> section and updated <i>Ordering Information</i> table	1, 7

For pricing, delivery, and ordering information, please contact Maxim Direct at 1-888-629-4642, or visit Maxim Integrated's website at [www.maximintegrated.com](http://www.maximintegrated.com).

Maxim Integrated cannot assume responsibility for use of any circuitry other than circuitry entirely embodied in a Maxim Integrated product. No circuit patent licenses are implied. Maxim Integrated reserves the right to change the circuitry and specifications without notice at any time. The parametric values (min and max limits) shown in the Electrical Characteristics table are guaranteed. Other parametric values quoted in this data sheet are provided for guidance.



Компания «Океан Электроники» предлагает заключение долгосрочных отношений при поставках импортных электронных компонентов на взаимовыгодных условиях!

Наши преимущества:

- Поставка оригинальных импортных электронных компонентов напрямую с производств Америки, Европы и Азии, а так же с крупнейших складов мира;
- Широкая линейка поставок активных и пассивных импортных электронных компонентов (более 30 млн. наименований);
- Поставка сложных, дефицитных, либо снятых с производства позиций;
- Оперативные сроки поставки под заказ (от 5 рабочих дней);
- Экспресс доставка в любую точку России;
- Помощь Конструкторского Отдела и консультации квалифицированных инженеров;
- Техническая поддержка проекта, помощь в подборе аналогов, поставка прототипов;
- Поставка электронных компонентов под контролем ВП;
- Система менеджмента качества сертифицирована по Международному стандарту ISO 9001;
- При необходимости вся продукция военного и аэрокосмического назначения проходит испытания и сертификацию в лаборатории (по согласованию с заказчиком);
- Поставка специализированных компонентов военного и аэрокосмического уровня качества (Xilinx, Altera, Analog Devices, Intersil, Interpoint, Microsemi, Actel, Aeroflex, Peregrine, VPT, Syfer, Eurofarad, Texas Instruments, MS Kennedy, Miteq, Cobham, E2V, MA-COM, Hittite, Mini-Circuits, General Dynamics и др.);

Компания «Океан Электроники» является официальным дистрибьютором и эксклюзивным представителем в России одного из крупнейших производителей разъемов военного и аэрокосмического назначения «JONHON», а так же официальным дистрибьютором и эксклюзивным представителем в России производителя высокотехнологичных и надежных решений для передачи СВЧ сигналов «FORSTAR».



## JONHON

«JONHON» (основан в 1970 г.)

Разъемы специального, военного и аэрокосмического назначения:

(Применяются в военной, авиационной, аэрокосмической, морской, железнодорожной, горно- и нефтедобывающей отраслях промышленности)

«FORSTAR» (основан в 1998 г.)

ВЧ соединители, коаксиальные кабели, кабельные сборки и микроволновые компоненты:

(Применяются в телекоммуникациях гражданского и специального назначения, в средствах связи, РЛС, а так же военной, авиационной и аэрокосмической отраслях промышленности).



Телефон: 8 (812) 309-75-97 (многоканальный)

Факс: 8 (812) 320-03-32

Электронная почта: [ocean@oceanchips.ru](mailto:ocean@oceanchips.ru)

Web: <http://oceanchips.ru/>

Адрес: 198099, г. Санкт-Петербург, ул. Калинина, д. 2, корп. 4, лит. А