

# IFX1040

High Speed CAN-Transceiver with Stand-By Mode and Bus wake-up

## Data Sheet

Rev. 1.0, 2011-11-4

Standard Power

## Table of Contents

1	Overview .....	3
2	Pin Configuration .....	4
3	Block Diagram .....	5
4	Application Information .....	6
5	Electrical Characteristics .....	11
6	Diagrams .....	15
7	Application .....	17
8	Package Outlines .....	18
9	Revision History .....	19



## 1 Overview

### Features

- CAN data transmission rate up to 1 MBaud
- Compatible to ISO 11898-2 and ISO 11898-5
- Low power mode with remote wake-up via CAN bus
- Wake signaling by RxD toggle
- No BUS load in stand-by mode
- Wide common mode range for electromagnetic immunity (EMI)
- Digital inputs compatible to 3.3 and 5 V logic devices
- Split termination to stabilize the recessive level
- TxD time-out function
- Overtemperature protection
- Green Product (RoHS compliant)

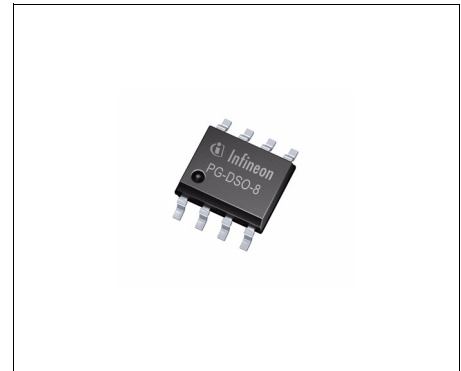

**PG-DSO-8**

### Description

The CAN-transceiver IFX1040SJ is a monolithic integrated circuit in a PG-DSO-8 package for high speed differential mode data transmission (up to 1 Mbaud) and reception in industrial applications. It works as an interface between the CAN protocol controller and the physical bus lines compatible to ISO Standard 11898-2 and ISO Standard 11898-5.

The IFX1040SJ is designed to provide an excellent passive behavior when the transceiver is switched off and a remote wake-up capability via CAN bus in low power mode. This supports networks with partially un-powered nodes.

The IFX1040SJ has two operation modes, the normal and the stand-by mode. These modes can be chosen by the STB pin. If the IFX1040SJ is in stand-by mode and a message on the bus is detected, the IFX1040SJ changes the level at the RxD pin corresponding to the bus signal (wake-up flag).

The IFX1040SJ is designed to withstand the severe conditions of industrial applications.

Type	Package	Marking
IFX1040SJ	PG-DSO-8	1040SJ

## 2 Pin Configuration

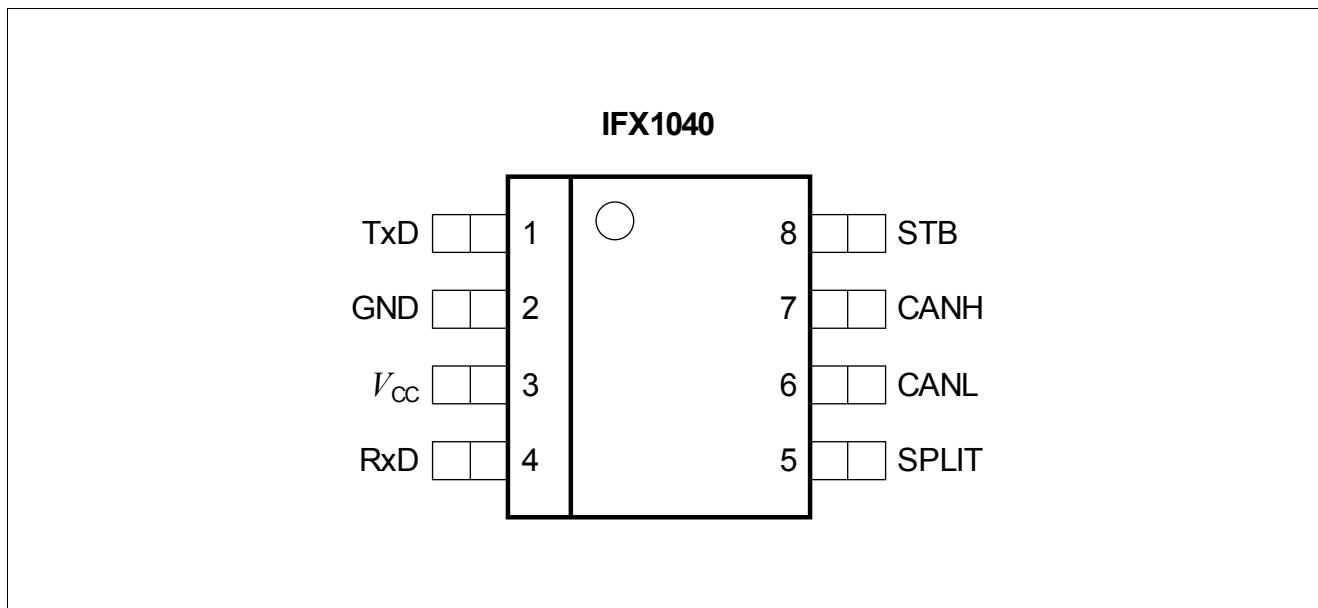

Figure 1 Pin Configuration IFX1040SJ (top view)

Table 1 Pin Definitions and Functions IFX1040SJ

Pin No.	Symbol	Function
1	TxD	<b>CAN transmit data input</b> ; 20 kΩ pull-up, LOW in dominant state
2	GND	<b>Ground</b>
3	V <sub>CC</sub>	<b>5 V Supply input</b> ; 100 nF decoupling capacitor required
4	RxD	<b>CAN receive data output</b> ; LOW in dominant state,
5	SPLIT	<b>Split termination output</b> ; to support the recessive voltage level of the bus lines
6	CANL	<b>Low line I/O</b> ; LOW in dominant state
7	CANH	<b>High line I/O</b> ; HIGH in dominant state
8	STB	<b>Mode Control Input</b> ; Internal pull-up, see <a href="#">Figure 3</a>

### 3 Block Diagram

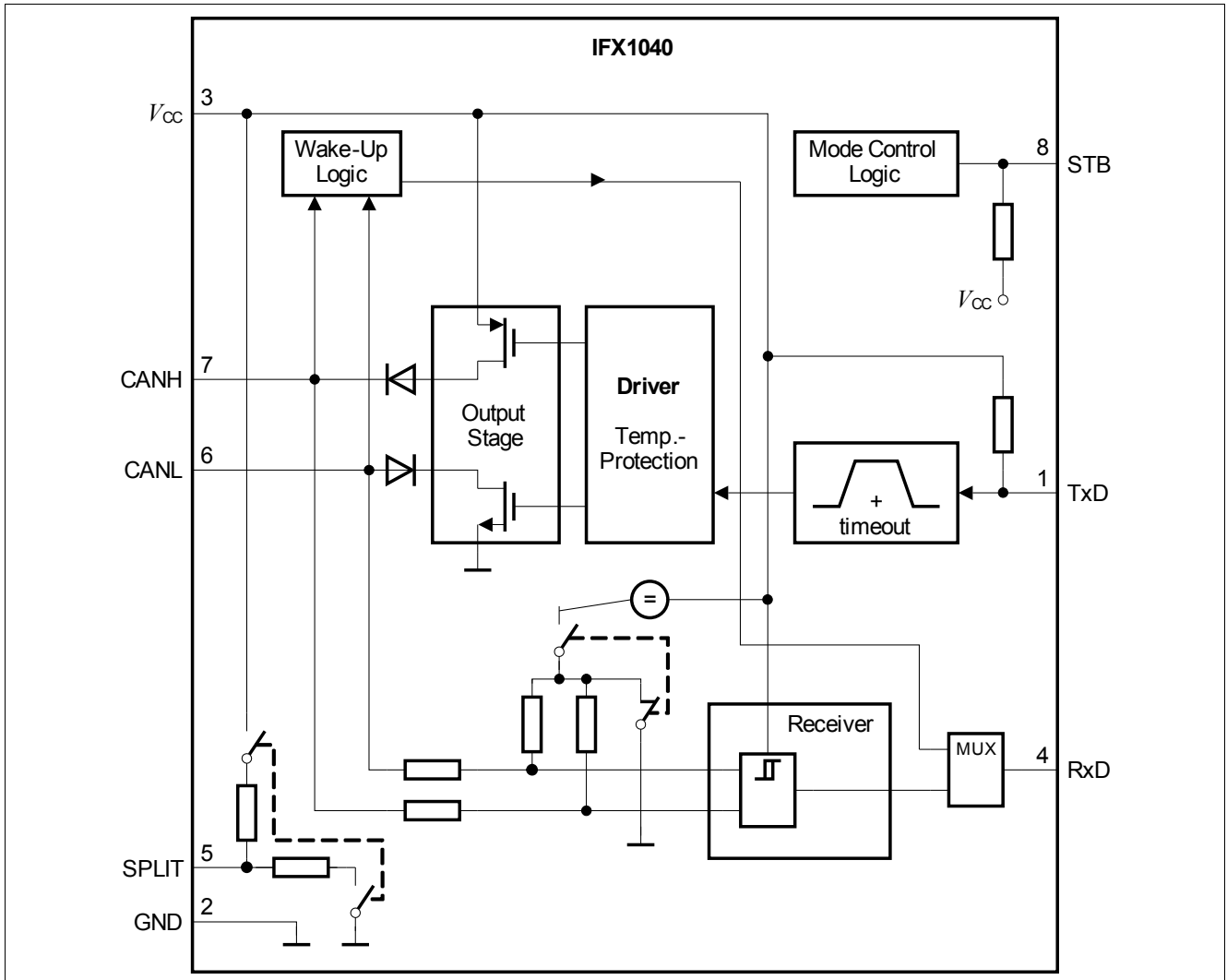
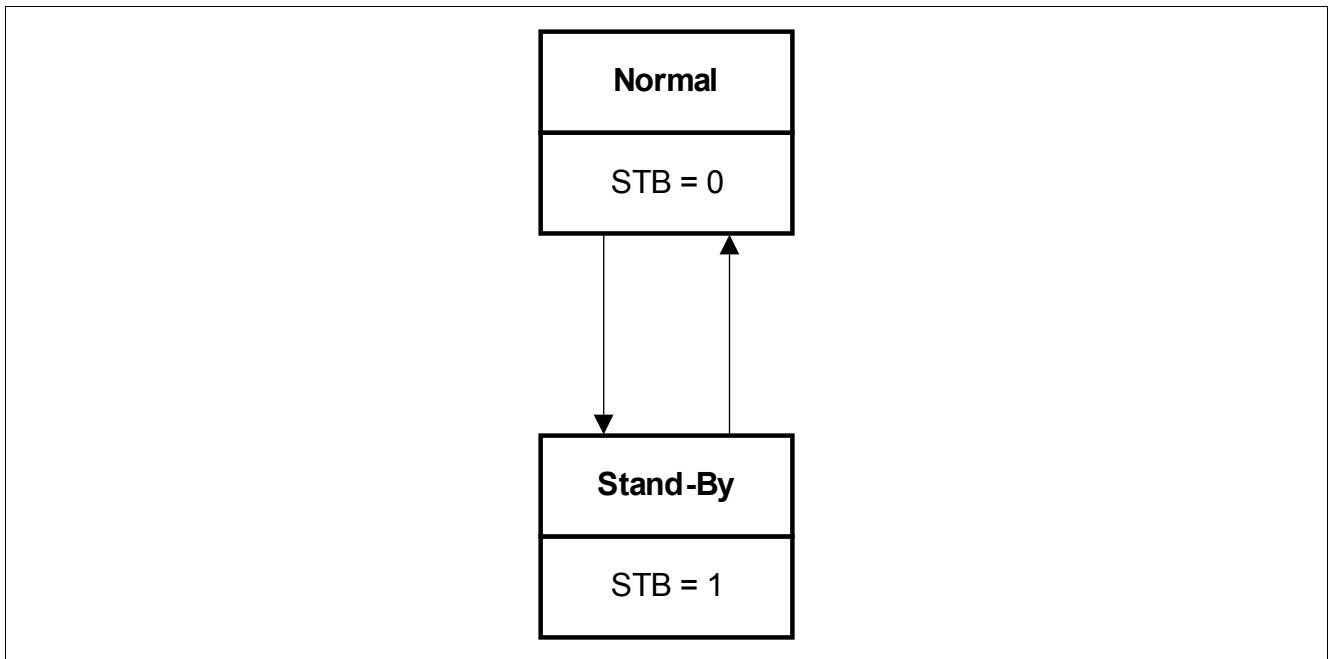

Figure 2 Block Diagram IFX1040SJ

## 4 Application Information

The IFX1040SJ has two operation modes, the normal and the standby mode. These modes can be controlled with the STB pin (see [Figure 3](#), [Table 2](#)). The STB pin has an implemented pull-up, so if there is no signal applied to STB or STB = HIGH, the standby mode is activated. To transfer the IFX1040SJ into the normal mode, STB has to be switched to LOW.



**Figure 3 Mode State Diagram**

**Table 2 Truth Table**

Mode	STB	Event	RxD	BUS Termination
Normal	low	bus dominant	low	$V_{CC}/2$
		bus recessive	high	
Stand by	high	wake-up via CAN bus detected	low/high <sup>1)</sup>	GND
		no wake-up detected	high	

1) Signal at RxD changes corresponding to the bus signal during stand by mode. See [Figure 6](#)

### Normal Mode

This mode is designed for the normal data transmission/reception within the HS-CAN network.

### Transmission

The signal from the  $\mu C$  is applied to the TxD input of the IFX1040SJ. Now the bus driver switches the CANH/L output stages to transfer this input signal to the CAN bus lines.

**TxD Time-out Feature**

If the TxD signal is dominant for a time  $t > t_{TxD}$  the TxD time-out function deactivates the transmitter of the IFX1040. This is realized to prevent the bus from being blocked permanently dominant due to an error like in case of a malfunctioning microcontroller.

The transmission is released again, after a rising edge at TxD has been detected.

As a result of the TxD Time-Out function, the minimum bit rate is limited. The minimum achievable bit rate can be calculated by the maximum number of consecutive dominant bits allowed in the system. It is given by the maximum number of dominant bits allowed in the system divided by the TxD permanent dominant disable time  $t_{TxD}$ .

**Reduced Electromagnetic Emission**

The bus driver has an implemented control to reduce the electromagnetic emission (EME). This is achieved by controlling the symmetry of the slope, resp. of CANH and CANL.

**Overtemperature**

The driver stages are protected against overtemperature. Exceeding the shutdown temperature results in deactivation of the driving stages at CANH/L. To avoid a bit failure after cooling down, the signals can be transmitted again only after a dominant to recessive edge at TxD.

**Figure 4** shows the way how the transmission stage is deactivated and activated again. First an over temperature condition causes the transmission stage to deactivate. After the over temperature condition is no longer present, the transmission is only possible after the TxD signal has changed to recessive level.

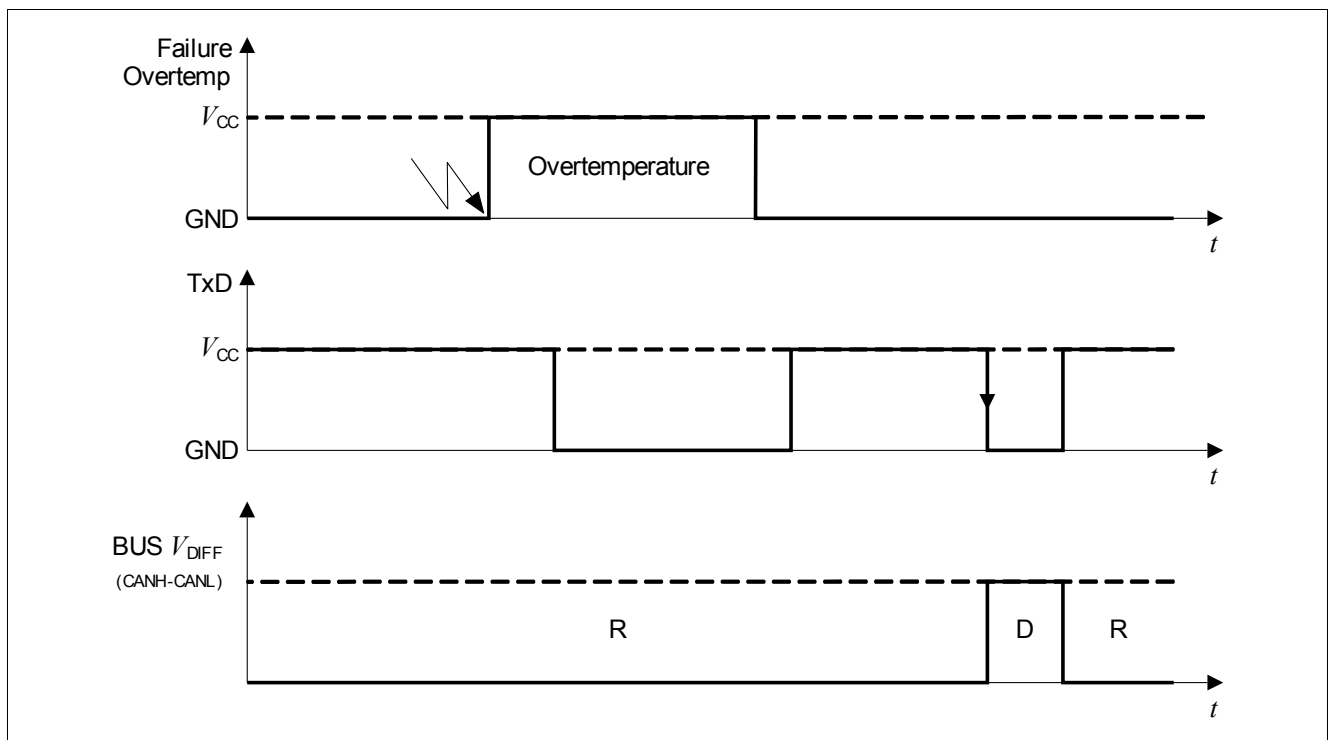

**Figure 4 Release of the Transmission after Overtemperature**

**Reception**

The analog CAN bus signals are converted into a digital signal at RxD via the differential input receiver. The RxD signal is switched to RxD output pin via the multiplexer (MUX), see **Figure 2**.

In normal mode the split pin is used to stabilize the recessive common mode signal.

### Standby Mode

The standby mode is designed to switch the IFX1040SJ into a low power mode with minimum current consumption. The driving stages and the receiver are deactivated. Only the relevant circuitry to guarantee a correct handling of the CAN bus wake-up is still active. This wake-up receiver is also designed to show an excellent immunity against electromagnetic noise (EMI).

### Change into Standby Mode during CAN Bus Failure

It is possible to change from normal mode into the standby mode if the bus is dominant due to a bus failure without setting the RxD wake flag to LOW. The advantage is, that the IFX1040SJ can be kept in the standby mode even if a bus failure occurs.

**Figure 5** shows this mechanism in detail. During a bus network failure, the bus might be dominant. Normal communication is not possible until the failure is removed. To reduce the current consumption, it makes sense to switch over to standby mode. This is possible with the IFX1040SJ. If the dominant signal switches back to recessive level, e.g. failure removed, a wake-up via CAN bus (recessive to dominant signal detected) is possible.

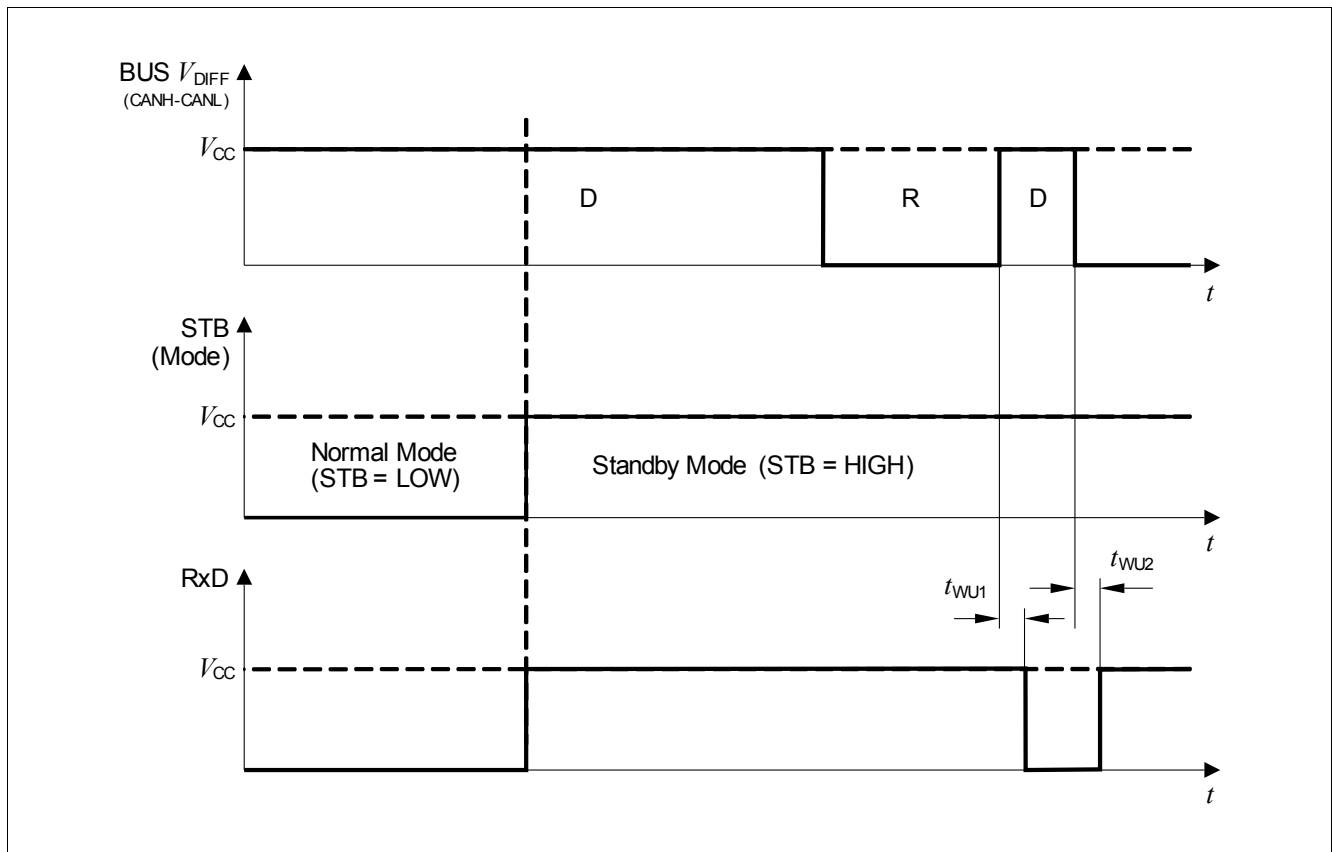

**Figure 5** Go-To Standby Mode during Bus Dominant Condition



**Wake-up via CAN Message**

During standby mode, a dominant CAN message on the bus longer than the filtering time  $t > t_{WU1}$ , leads to the activation of the wake-up. The wake-up during standby mode is signaled with the RxD output pin. A dominant signal longer  $t > t_{WU1}$  on the CAN bus switches the RxD level to LOW, with a following recessive signal on the CAN bus longer  $t > t_{WU2}$  the RxD level is switched to high, see **Figure 6**.

The  $\mu$ C is able to detect this change at RxD and switch the transceiver into the normal mode.

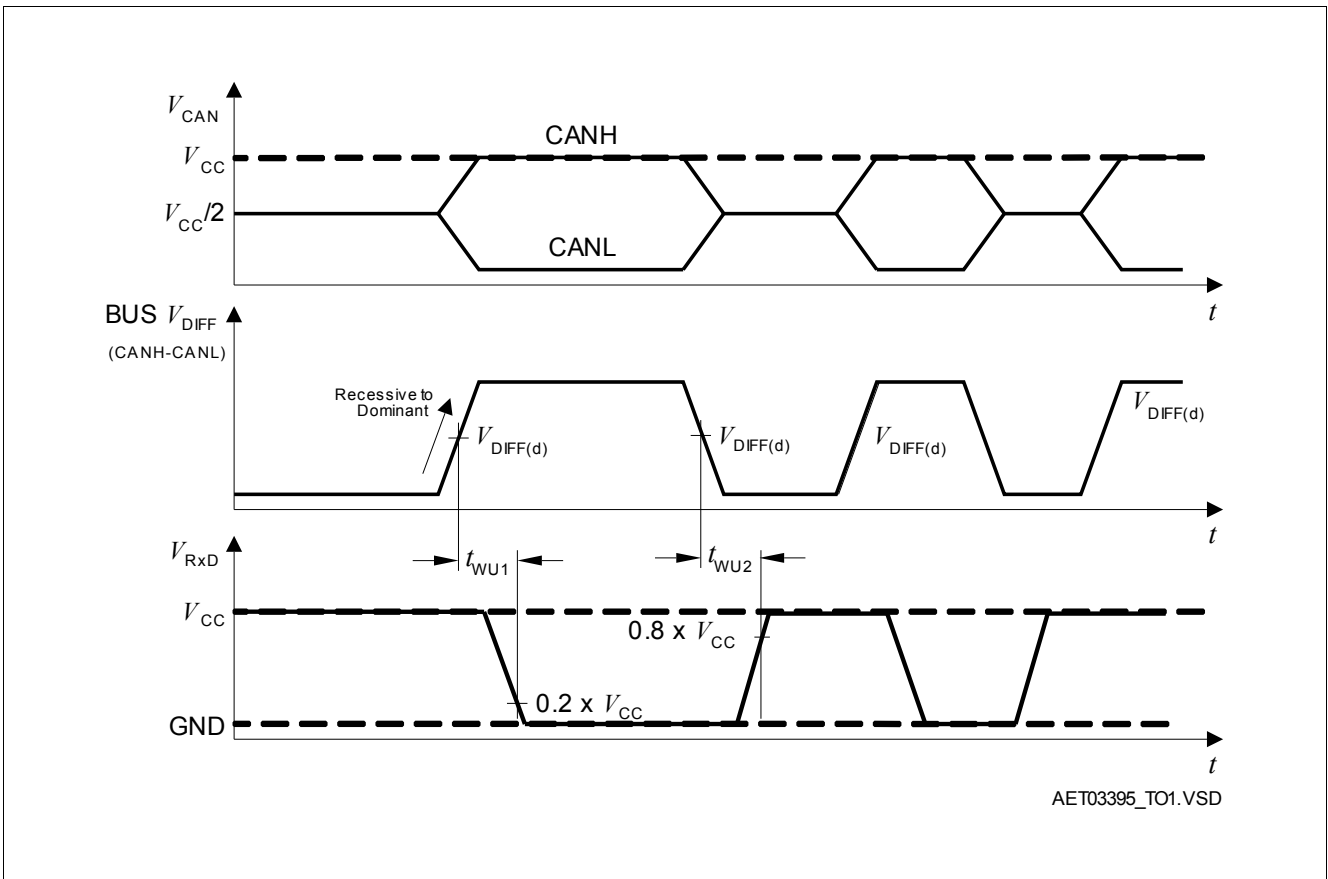
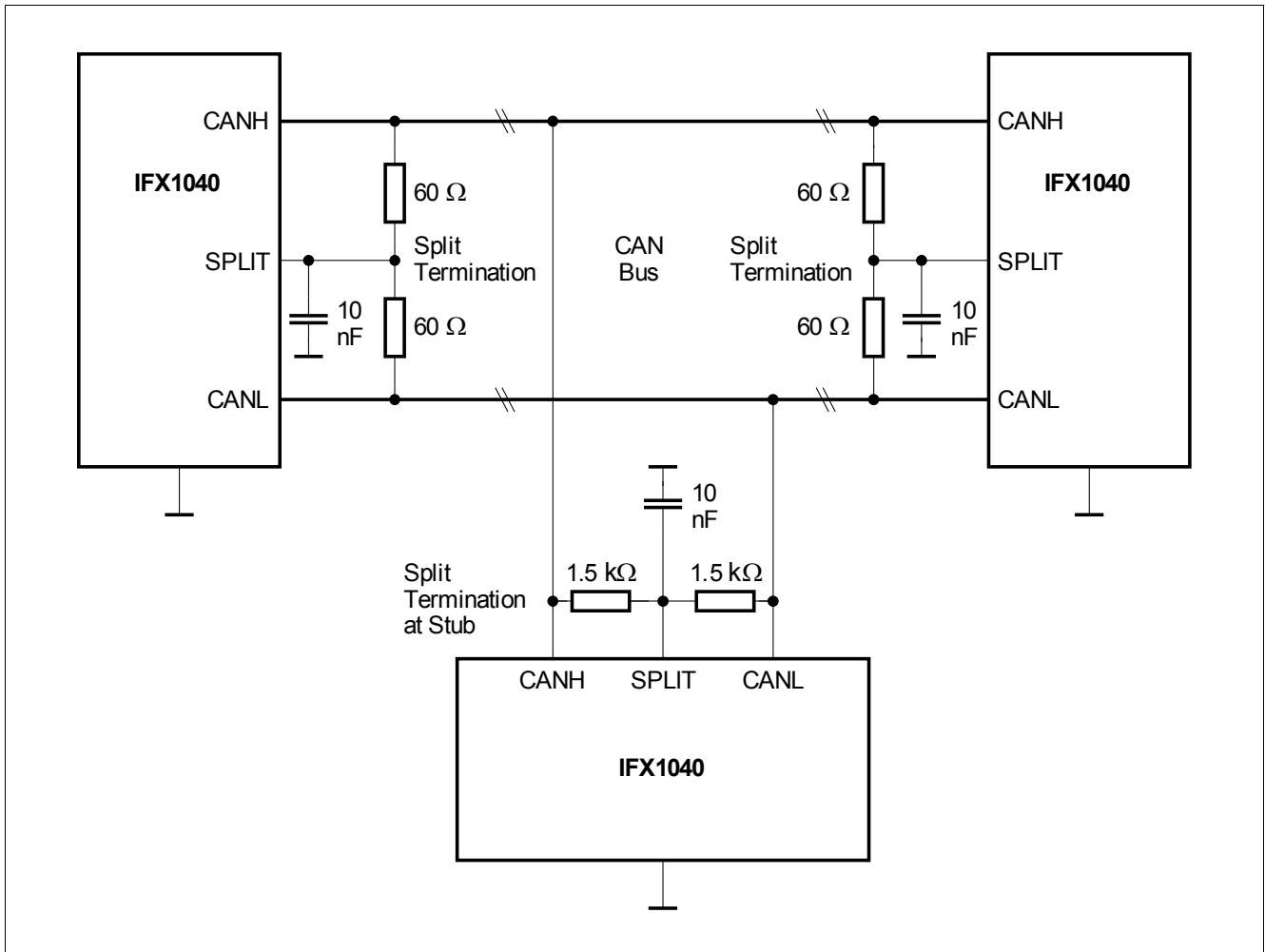

**Figure 6** Wake-up behavior

**Split Circuit**

The split circuitry is activated during normal mode and deactivated (SPLIT pin floating) during standby mode. The SPLIT pin is used to stabilize the recessive common mode signal in normal mode. This is realized with a stabilized voltage of  $0.5 V_{CC}$  at SPLIT.

A correct application of the SPLIT pin is shown in **Figure 7**. The split termination for the left and right node is realized with two  $60 \Omega$  resistances and one  $10 \text{ nF}$  capacitor. The center node in this example is a stub node and the recommended value for the split resistances is  $1.5 \text{ k}\Omega$ .



**Figure 7 Application of the SPLIT Pin for Normal Nodes and one Stub Node**

**Other Features**

**Fail Safe**

If the device is supplied but there is no signal at the digital inputs, the TxD and STB have an internal pull-up path, to prevent the transceiver to switch into the normal mode or send a dominant signal on the bus.

**Un-supplied Node**

The CANH/CANL pins remain high ohmic, if the transceiver is un-supplied.

## 5 Electrical Characteristics

**Table 3 Absolute Maximum Ratings**

Parameter	Symbol	Limit Values		Unit	Remarks
		Min.	Max.		
<b>Voltages</b>					
Supply voltage	$V_{CC}$	-0.3	5.5	V	–
CAN bus voltage (CANH, CANL)	$V_{CANH/L}$	-32	40	V	–
CAN bus differential voltage CANH, CANL, SPLIT	$V_{CAN\ diff}$	-40	40	V	CANH - CANL <  40 V  CANH - SPLIT <  40 V  CANL - SPLIT <  40 V
Input voltage at SPLIT	$V_{SPLIT}$	-27	40	V	–
Logic voltages at STB, TxD, RxD	$V_I$	-0.3	$V_{CC}$	V	$0\text{ V} < V_{CC} < 5.5\text{ V}$
Electrostatic discharge voltage at CANH, CANL, SPLIT vs. GND	$V_{ESD}$	-6	6	kV	Human Body Model (100 pF via 1.5 kW)
Electrostatic discharge voltage	$V_{ESD}$	-2	2	kV	Human Body Model (100 pF via 1.5 kW)
<b>Temperatures</b>					
Junction Temperature	$T_j$	-40	150	°C	–
Storage Temperature	$T_{stg}$	-50	150	°C	–

Note: Maximum ratings are absolute ratings; exceeding any one of these values may cause irreversible damage to the integrated circuit.

### 5.1 Operating Range

**Table 4 Operating Range**

Parameter	Symbol	Limit Values		Unit	Remarks
		Min.	Max.		
Supply voltage	$V_{CC}$	4.75	5.25	V	–
Junction temperature	$T_j$	-40	125	°C	–
<b>Thermal Resistances</b>					
Junction ambient	$R_{thj-a}$	–	185	K/W	<sup>1)</sup>
<b>Thermal Shutdown (junction temperature)</b>					
Thermal shutdown temperature	$T_{jsD}$	150	190	°C	–
Thermal shutdown hyst.	$\Delta T$	–	10	K	–

1) Calculation of the junction temperature  $T_j = T_{amb} + P \times R_{thj-a}$

**Electrical Characteristics**
**Table 5 Electrical Characteristics**

4.75 V <  $V_{CC}$  < 5.25 V;  $R_L = 60 \Omega$ ;  $-40 \text{ }^\circ\text{C} < T_j < 125 \text{ }^\circ\text{C}$ ; all voltages with respect to ground; positive current flowing into pin; unless otherwise specified.

Parameter	Symbol	Limit Values			Unit	Remarks
		Min.	Typ.	Max.		
<b>Current Consumption</b>						
Current consumption	$I_{CC}$	–	6	10	mA	recessive state; $V_{\text{TXD}} = V_{CC}$
Current consumption	$I_{CC}$	–	45	70	mA	dominant state; $V_{\text{TXD}} = 0 \text{ V}$
Current consumption	$I_{CC, \text{stb}}$	–	20	30	$\mu\text{A}$	stand-by mode; TxD = high
<b>Receiver Output RxD</b>						
HIGH level output current	$I_{\text{RD,H}}$	–	-4	-2	mA	$V_{\text{RD}} = 0.8 \times V_{CC}$
		–	-100	–	$\mu\text{A}$	stand-by mode
LOW level output current	$I_{\text{RD,L}}$	2	4	–	mA	$V_{\text{RD}} = 0.2 \times V_{CC}$
Short circuit current	$I_{\text{SC,RxD}}$	–	15	20	mA	–
<b>Transmission Input TxD</b>						
HIGH level input voltage threshold	$V_{\text{TD,H}}$	2.0	–	–	V	recessive state
LOW level input voltage threshold	$V_{\text{TD,L}}$	–	–	0.8	V	dominant state
TxD pull-up resistance	$R_{\text{TD}}$	10	20	40	k $\Omega$	–
TxD input hysteresis	$V_{\text{TD hys}}$	–	200	–	mV	–
<b>Stand By Input (pin STB)</b>						
HIGH level input voltage threshold	$V_{\text{STB,H}}$	2.0	–	–	V	normal mode
LOW level input voltage threshold	$V_{\text{STB,L}}$	–	–	0.8	V	receive-only mode
STB pull-up resistance	$R_{\text{STB}}$	10	20	40	k $\Omega$	–
STB input hysteresis	$V_{\text{STB hys}}$	–	200	–	mV	–
<b>Split Termination Output (pin SPLIT)</b>						
Split output voltage	$V_{\text{SPLIT}}$	$0.3 \times V_{CC}$	$0.5 \times V_{CC}$	$0.7 \times V_{CC}$	V	normal mode; $-500 \mu\text{A} < I_{\text{SPLIT}} < 500 \mu\text{A}$
	$V_{\text{SPLIT}}$	$0.45 \times V_{CC}$	$0.5 \times V_{CC}$	$0.55 \times V_{CC}$	V	normal mode; no Load
Leakage current	$I_{\text{SPLIT}}$	-5	0	5	$\mu\text{A}$	standby mode; $-22 \text{ V} < V_{\text{SPLIT}} < 35 \text{ V}$
SPLIT output resistance	$R_{\text{SPLIT}}$	–	600	–	$\Omega$	–
<b>Bus Receiver</b>						
Differential receiver threshold voltage, normal mode	$V_{\text{diff,rdN}}$	–	0.8	0.9	V	recessive to dominant
	$V_{\text{diff,drN}}$	0.5	0.6	–	V	dominant to recessive
Differential receiver threshold, low power mode	$V_{\text{diff,rdLP}}$	–	0.9	1.15	V	recessive to dominant
	$V_{\text{diff,drLP}}$	0.4	0.8	–	V	dominant to recessive
Common Mode Range	CMR	-12	–	12	V	$V_{CC} = 5 \text{ V}$
Differential receiver hysteresis	$V_{\text{diff,hys}}$	–	200	–	mV	–
CANH, CANL input resistance	$R_i$	10	20	30	k $\Omega$	recessive state
Differential input resistance	$R_{\text{diff}}$	20	40	60	k $\Omega$	recessive state

**Electrical Characteristics**
**Table 5 Electrical Characteristics (cont'd)**

4.75 V <  $V_{CC}$  < 5.25 V;  $R_L = 60 \Omega$ ;  $-40 \text{ }^\circ\text{C} < T_j < 125 \text{ }^\circ\text{C}$ ; all voltages with respect to ground; positive current flowing into pin; unless otherwise specified.

Parameter	Symbol	Limit Values			Unit	Remarks
		Min.	Typ.	Max.		
<b>Bus Transmitter</b>						
CANL/CANH recessive output voltage	$V_{CANL/H}$	2.0	2.5	3.0	V	$V_{TxD} = V_{CC}$ ; no load
CANH, CANL recessive output voltage difference	$V_{diff}$	-500	–	50	mV	$V_{TxD} = V_{CC}$ ; no load
CANL dominant output voltage	$V_{CANL}$	0.5	–	2.25	V	$V_{TxD} = 0 \text{ V}$ ; $V_{CC} = 5 \text{ V}$
CANH dominant output voltage	$V_{CANH}$	2.75	–	4.5	V	$V_{TxD} = 0 \text{ V}$ ; $V_{CC} = 5 \text{ V}$
CANH, CANL dominant output voltage difference $V_{diff} = V_{CANH} - V_{CANL}$	$V_{diff}$	1.5	–	3.0	V	$V_{TxD} = 0 \text{ V}$ ; $V_{CC} = 5 \text{ V}$
CANL short circuit current	$I_{CANLsc}$	50	80	200	mA	$V_{CANLshort} = 18 \text{ V}$
CANH short circuit current	$I_{CANHsc}$	-200	-80	-50	mA	$V_{CANHshort} = 0 \text{ V}$
Leakage current	$I_{CANH,L,ik}$	-	-	-5	$\mu\text{A}$	$V_{CC} = 0 \text{ V}$ ; $0 \text{ V} < V_{CANH,L} < 5 \text{ V}$
<b>Dynamic CAN-Transceiver Characteristics</b>						
Propagation delay TxD-to-RxD LOW (recessive to dominant)	$t_{d(L),TR}$	–	150	255	ns	$C_L = 47 \text{ pF}$ ; $R_L = 60 \Omega$ ; $V_{CC} = 5 \text{ V}$ ; $C_{RxD} = 15 \text{ pF}$
Propagation delay TxD-to-RxD HIGH (dominant to recessive)	$t_{d(H),TR}$	–	150	255	ns	$C_L = 47 \text{ pF}$ ; $R_L = 60 \Omega$ ; $V_{CC} = 5 \text{ V}$ ; $C_{RxD} = 15 \text{ pF}$
Propagation delay TxD LOW to bus dominant	$t_{d(L),T}$	–	50	120	ns	$C_L = 47 \text{ pF}$ ; $R_L = 60 \Omega$ ; $V_{CC} = 5 \text{ V}$
Propagation delay TxD HIGH to bus recessive	$t_{d(H),T}$	–	50	120	ns	$C_L = 47 \text{ pF}$ ; $R_L = 60 \Omega$ ; $V_{CC} = 5 \text{ V}$
Propagation delay bus dominant to RxD LOW	$t_{d(L),R}$	–	100	135	ns	$C_L = 47 \text{ pF}$ ; $R_L = 60 \Omega$ ; $V_{CC} = 5 \text{ V}$ ; $C_{RxD} = 15 \text{ pF}$
Propagation delay bus recessive to RxD HIGH	$t_{d(H),R}$	–	100	135	ns	$C_L = 47 \text{ pF}$ ; $R_L = 60 \Omega$ ; $V_{CC} = 5 \text{ V}$ ; $C_{RxD} = 15 \text{ pF}$
Min. dominant time for bus wake-up signal (RxD high to low)	$t_{WU1}$	0.75	3	5	$\mu\text{s}$	$t_{WU1} = t_{d(L),R} + t_{WU}$ see <a href="#">Figure 6</a>

**Table 5 Electrical Characteristics (cont'd)**

4.75 V <  $V_{CC}$  < 5.25 V;  $R_L = 60 \Omega$ ;  $-40 \text{ }^\circ\text{C} < T_j < 125 \text{ }^\circ\text{C}$ ; all voltages with respect to ground; positive current flowing into pin; unless otherwise specified.

Parameter	Symbol	Limit Values			Unit	Remarks
		Min.	Typ.	Max.		
Min. recessive time for bus wake-up signal (RxD low to high)	$t_{WU2}$	0.75	3	5	$\mu\text{s}$	$t_{WU2} = t_{d(H),R} + t_{WU}$ see <a href="#">Figure 6</a>
TxD permanent dominant disable time	$t_{TxD}$	0.3	–	1.0	ms	–

6 Diagrams

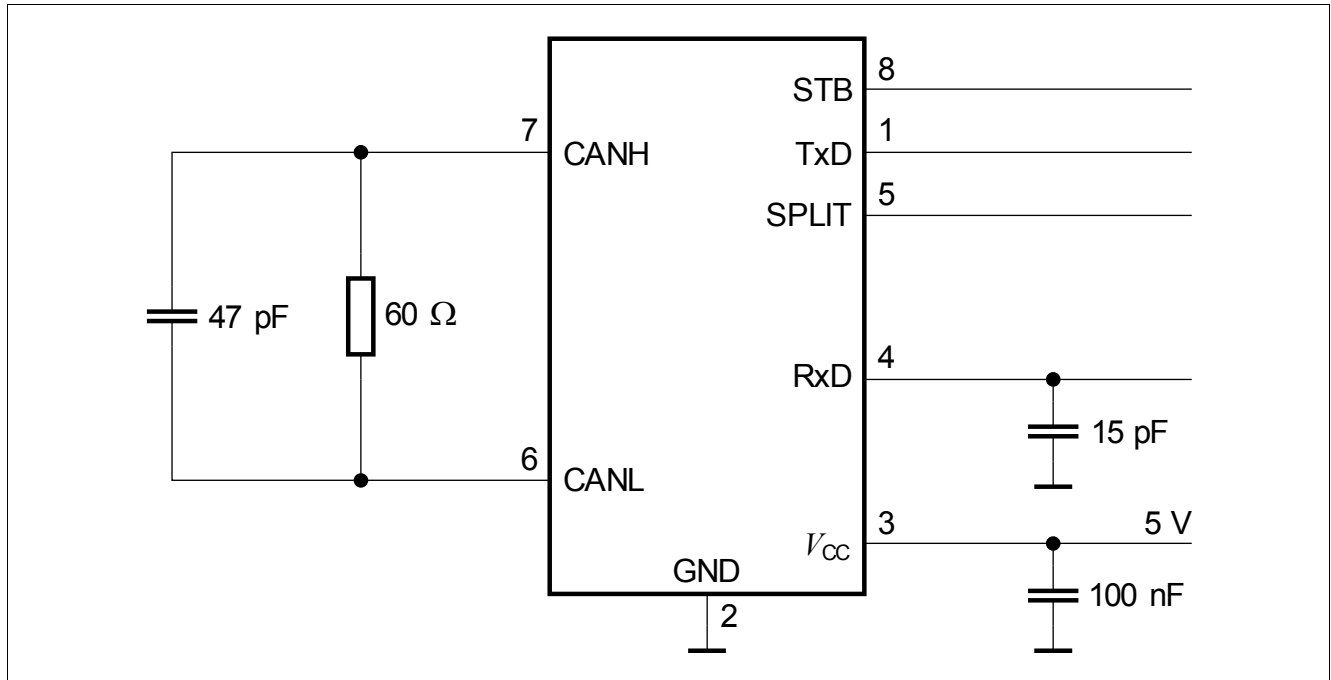

Figure 8 Test Circuit for Dynamic Characteristics

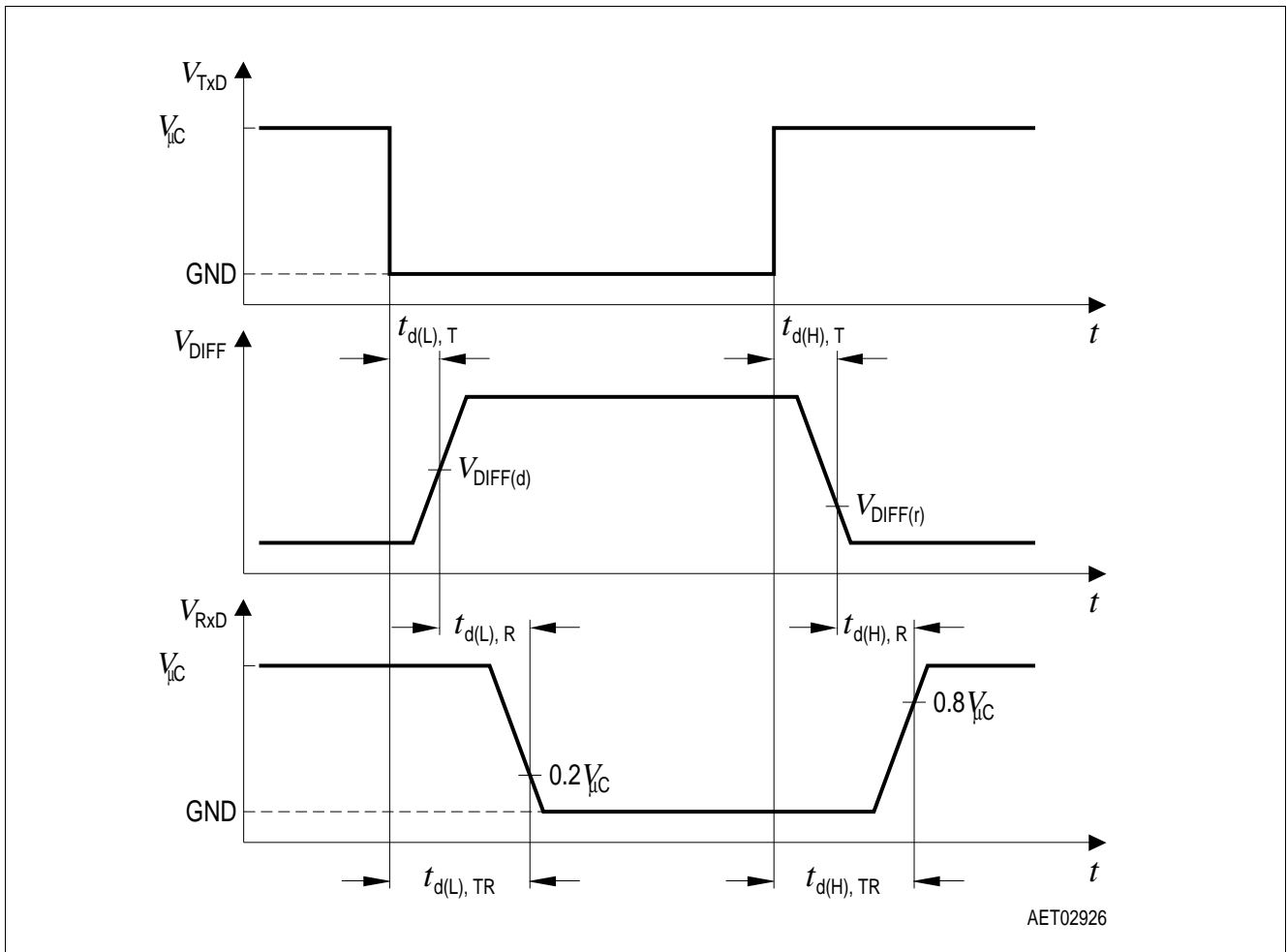

Figure 9 Timing Diagrams for Dynamic Characteristics



## 7 Application

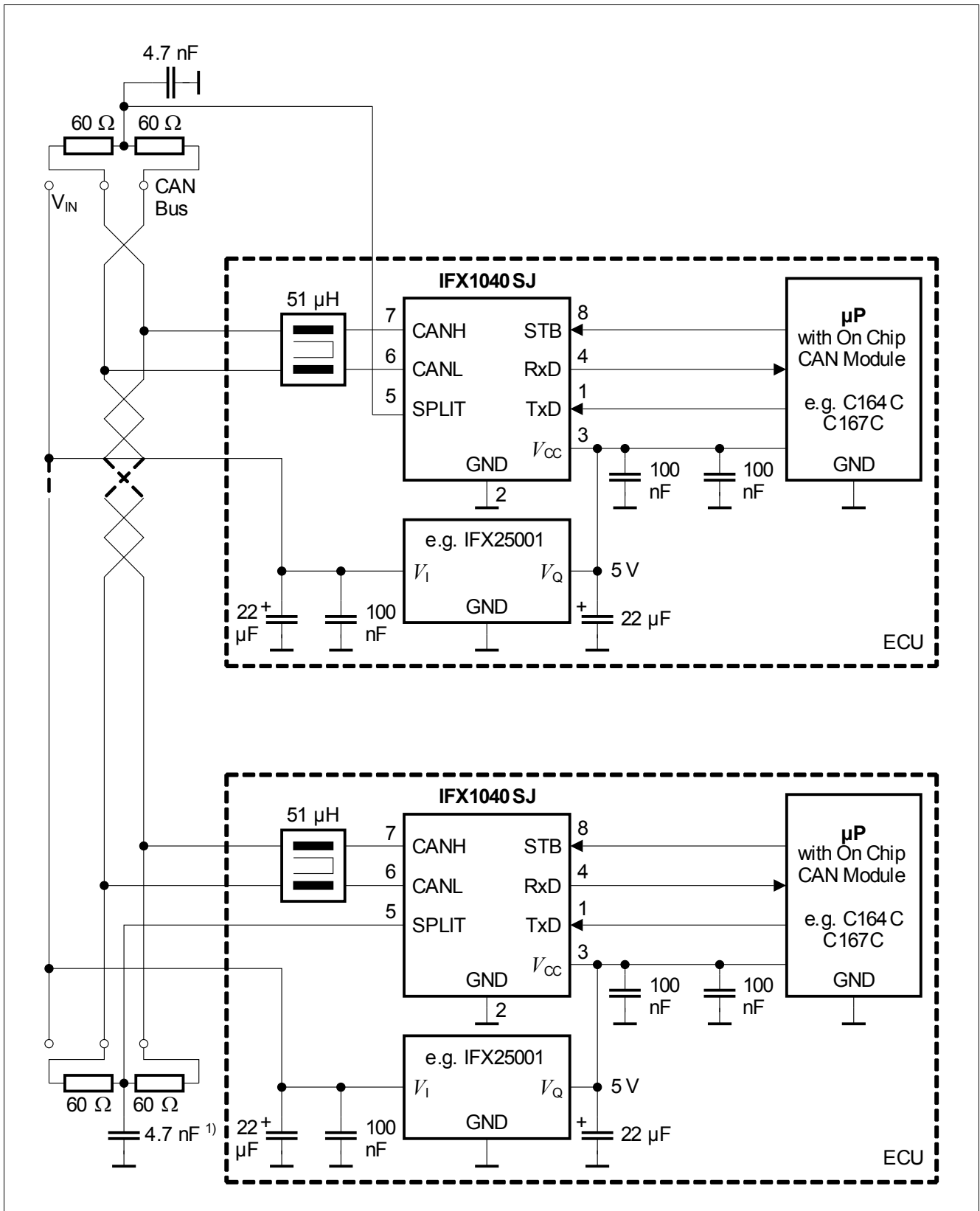
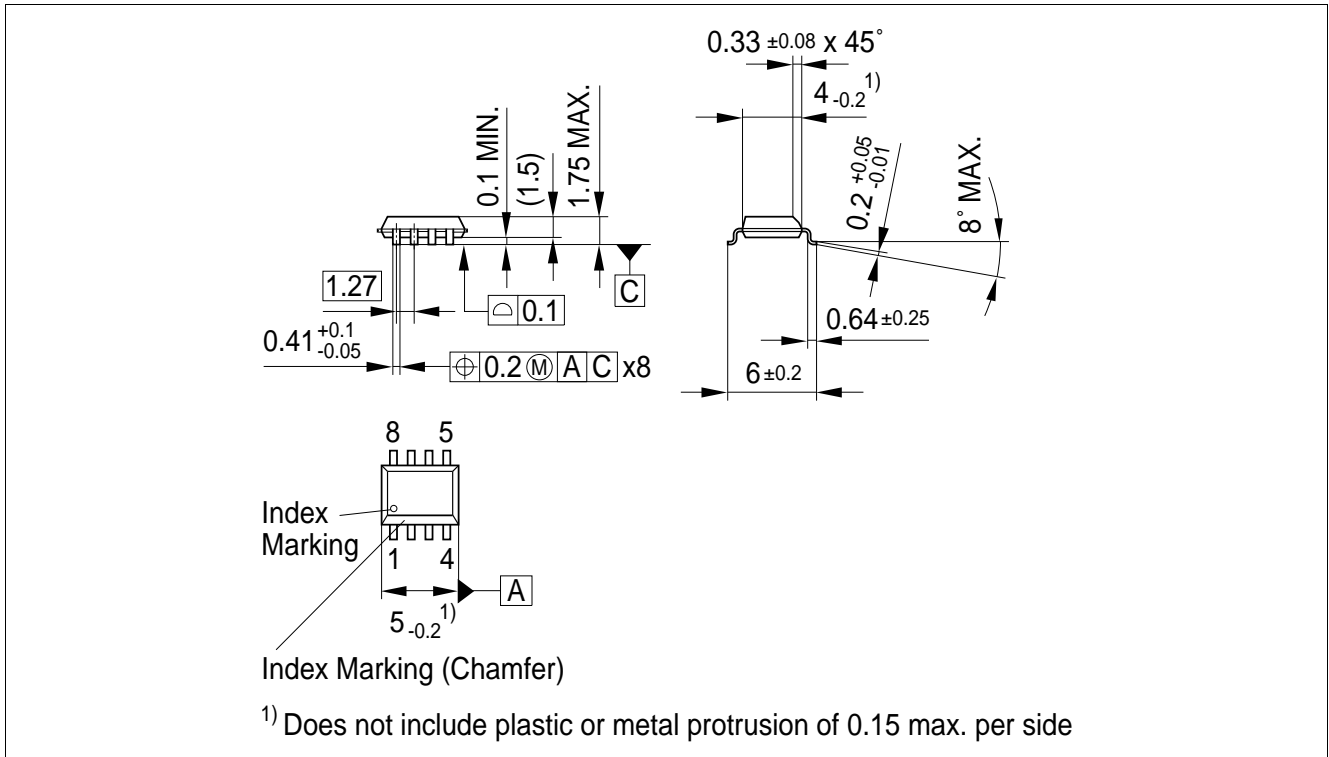

Figure 10 Application Circuit

## 8 Package Outlines



**Figure 11** PG-DSO-8 (Plastic Dual Small Outline), lead free version

### Green Product (RoHS compliant)

To meet the world-wide customer requirements for environmentally friendly products and to be compliant with government regulations the device is available as a green product. Green products are RoHS-Compliant (i.e Pb-free finish on leads and suitable for Pb-free soldering according to IPC/JEDEC J-STD-020).

## 9 Revision History

Revision	Date	Changes
1.0	2011-11-04	Data Sheet

**Edition 2011-11-4**

**Published by  
Infineon Technologies AG  
81726 Munich, Germany**

**© 2011 Infineon Technologies AG  
All Rights Reserved.**

### **Legal Disclaimer**

The information given in this document shall in no event be regarded as a guarantee of conditions or characteristics. With respect to any examples or hints given herein, any typical values stated herein and/or any information regarding the application of the device, Infineon Technologies hereby disclaims any and all warranties and liabilities of any kind, including without limitation, warranties of non-infringement of intellectual property rights of any third party.

### **Information**

For further information on technology, delivery terms and conditions and prices, please contact the nearest Infineon Technologies Office ([www.infineon.com](http://www.infineon.com)).

### **Warnings**

Due to technical requirements, components may contain dangerous substances. For information on the types in question, please contact the nearest Infineon Technologies Office.

The Infineon Technologies component described in this Data Sheet may be used in life-support devices or systems and/or automotive, aviation and aerospace applications or systems only with the express written approval of Infineon Technologies, if a failure of such components can reasonably be expected to cause the failure of that life-support automotive, aviation and aerospace device or system or to affect the safety or effectiveness of that device or system. Life support devices or systems are intended to be implanted in the human body or to support and/or maintain and sustain and/or protect human life. If they fail, it is reasonable to assume that the health of the user or other persons may be endangered.

# Mouser Electronics

Authorized Distributor

Click to View Pricing, Inventory, Delivery & Lifecycle Information:

[Infineon:](#)

[IFX1040SJUMA1](#)

Компания «Океан Электроники» предлагает заключение долгосрочных отношений при поставках импортных электронных компонентов на взаимовыгодных условиях!

Наши преимущества:

- Поставка оригинальных импортных электронных компонентов напрямую с производств Америки, Европы и Азии, а так же с крупнейших складов мира;
- Широкая линейка поставок активных и пассивных импортных электронных компонентов (более 30 млн. наименований);
- Поставка сложных, дефицитных, либо снятых с производства позиций;
- Оперативные сроки поставки под заказ (от 5 рабочих дней);
- Экспресс доставка в любую точку России;
- Помощь Конструкторского Отдела и консультации квалифицированных инженеров;
- Техническая поддержка проекта, помощь в подборе аналогов, поставка прототипов;
- Поставка электронных компонентов под контролем ВП;
- Система менеджмента качества сертифицирована по Международному стандарту ISO 9001;
- При необходимости вся продукция военного и аэрокосмического назначения проходит испытания и сертификацию в лаборатории (по согласованию с заказчиком);
- Поставка специализированных компонентов военного и аэрокосмического уровня качества (Xilinx, Altera, Analog Devices, Intersil, Interpoint, Microsemi, Actel, Aeroflex, Peregrine, VPT, Syfer, Eurofarad, Texas Instruments, MS Kennedy, Miteq, Cobham, E2V, MA-COM, Hittite, Mini-Circuits, General Dynamics и др.);

Компания «Океан Электроники» является официальным дистрибьютором и эксклюзивным представителем в России одного из крупнейших производителей разъемов военного и аэрокосмического назначения «JONHON», а так же официальным дистрибьютором и эксклюзивным представителем в России производителя высокотехнологичных и надежных решений для передачи СВЧ сигналов «FORSTAR».



## JONHON

«JONHON» (основан в 1970 г.)

Разъемы специального, военного и аэрокосмического назначения:

(Применяются в военной, авиационной, аэрокосмической, морской, железнодорожной, горно- и нефтедобывающей отраслях промышленности)

«FORSTAR» (основан в 1998 г.)

ВЧ соединители, коаксиальные кабели,  
кабельные сборки и микроволновые компоненты:

(Применяются в телекоммуникациях гражданского и специального назначения, в средствах связи, РЛС, а так же военной, авиационной и аэрокосмической отраслях промышленности).



Телефон: 8 (812) 309-75-97 (многоканальный)

Факс: 8 (812) 320-03-32

Электронная почта: [ocean@oceanchips.ru](mailto:ocean@oceanchips.ru)

Web: <http://oceanchips.ru/>

Адрес: 198099, г. Санкт-Петербург, ул. Калинина, д. 2, корп. 4, лит. А