



CYP15G0403DXB
CYV15G0403DXB
CYW15G0403DXB

Independent Clock Quad HOTLink II™ Transceiver

Features

- Second-generation HOTLink® technology
- Compliant to multiple standards
 - ESCON, DVB-ASI, SMPTE-292M, SMPTE-259M, Fibre Channel and Gigabit Ethernet (IEEE802.3z)
 - CPRI™ compliant
 - CYW15G0403DXB compliant to OBSAI-RP3
 - 8B/10B coded data or 10 bit uncoded data
- Quad channel transceiver operates from 195 to 1500 MBaud serial data rate
 - CYW15G0403DXB operates from 195 to 1540 MBaud
 - Aggregate throughput of up to 12 Gbits/second
- Second-generation HOTLink technology
- Truly independent channels
 - Each channel can operate at a different signaling rate
 - Each channel can transport a different type of data
- Selectable input/output clocking options
- Internal phase-locked loops (PLLs) with no external PLL components
- Dual differential PECL-compatible serial inputs per channel
- Internal DC-restoration
- Dual differential PECL-compatible serial outputs per channel
 - Source matched for 50Ω transmission lines
 - No external bias resistors required
 - Signaling-rate controlled edge-rates
- MultiFrame™ Receive Framer provides alignment options
 - Bit and byte alignment
 - Comma or Full K28.5 detect
 - Single or Multi-byte Framer for byte alignment
 - Low-latency option
- Synchronous LVTTTL parallel interface
- JTAG boundary scan
- Built-In Self-Test (BIST) for at-speed link testing
- Compatible with
 - Fiber-optic modules
 - Copper cables
 - Circuit board traces

- Per-channel Link Quality Indicator
 - Analog signal detect
 - Digital signal detect
- Low-power 3W @ 3.3V typical
- Single 3.3V supply
- 256-ball thermally enhanced BGA
- Pb-Free package option available
- 0.25μ BiCMOS technology

Functional Description

The CYP(V)15G0403DXB^[1] Independent Clock Quad HOTLink II™ Transceiver is a point-to-point or point-to-multi-point communications building block enabling transfer of data over a variety of high-speed serial links like optical fiber, balanced, and unbalanced copper transmission lines. The signaling rate can be anywhere in the range of 195 to 1500 MBaud per serial link. Each channel operates independently with its own reference clock allowing different rates. Each transmit channel accepts parallel characters in an Input Register, encodes each character for transport, and then converts it to serial data. Each receive channel accepts serial data and converts it to parallel data, decodes the data into characters, and presents these characters to an Output Register. [Figure 1 on page 2](#) illustrates typical connections between independent host systems and corresponding CYP(V)(W)15G0403DXB chips

The CYW15G0403DXB^[1] operates from 195 to 1540 MBaud, which includes operation at the OBSAI RP3 datarate of both 1536 MBaud and 768 MBaud.

The CYV15G0403DXB satisfies the SMPTE-259M and SMPTE-292M compliance as per SMPTE EG34-1999 Pathological Test Requirements.

As a second-generation HOTLink device, the CYP(V)(W)15G0403DXB extends the HOTLink family with enhanced levels of integration and faster data rates, while maintaining serial-link compatibility (data, command, and BIST) with other HOTLink devices. The transmit (TX) section of the CYP(V)(W)15G0403DXB Quad HOTLink II consists of four independent byte-wide channels. Each channel can accept either 8-bit data characters or preencoded 10-bit transmission characters. Data characters may be passed from the Transmit Input Register to an integrated 8B/10B Encoder to improve their serial transmission characteristics. These encoded characters are then serialized and output from dual Positive ECL (PECL) compatible differential transmission-line drivers at a bit-rate of either 10 or 20 times the input reference clock for that channel.

Note

1. CYV15G0403DXB refers to SMPTE 259M and SMPTE 292M compliant devices. CYW15G0403DXB refers to OBSAI RP3 compliant devices (maximum operating data rate is 1540 MBaud). CYP15G0403DXB refers to devices not compliant to SMPTE 259M and SMPTE 292M pathological test requirements and also OBSAI RP3 operating datarate of 1536 MBaud. CYP(V)(W)15G0403DXB refers to all three devices.

Figure 1. HOTLink II™ System Connections

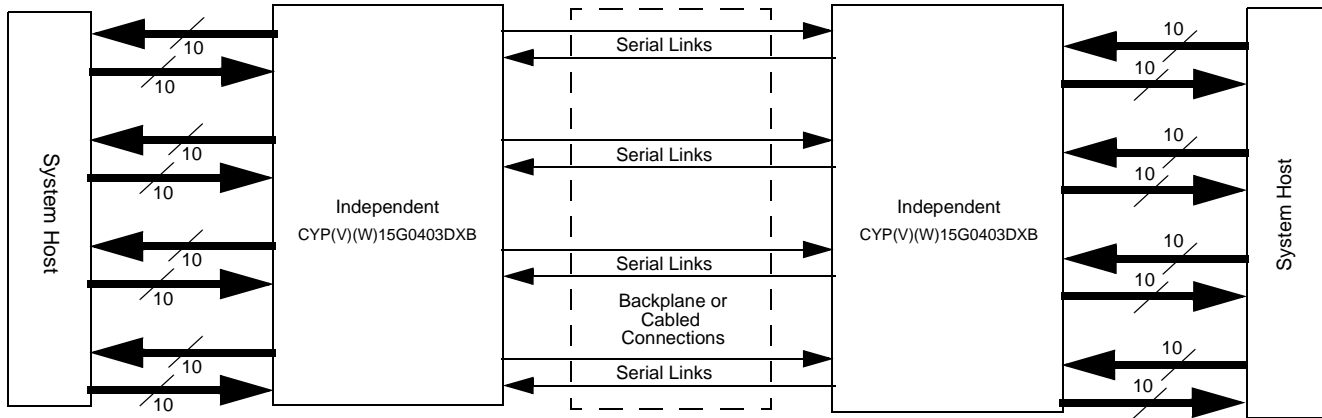

The receive (RX) section of the CYP(V)(W)15G0403DXB Quad HOTLink II consists of four independent byte-wide channels. Each channel accepts a serial bit-stream from one of two PECL-compatible differential line receivers, and using a completely integrated Clock and Data Recovery PLL, recovers the timing information necessary for data reconstruction. Each recovered bit-stream is deserialized and framed into characters, 8B/10B decoded, and checked for transmission errors. Recovered decoded characters are then written to an internal Elasticity Buffer, and presented to the destination host system.

The integrated 8B/10B encoder/decoder may be bypassed for systems that present externally encoded or scrambled data at the parallel interface.

The parallel I/O interface may be configured for numerous forms of clocking to provide the highest flexibility in system architecture. In addition to clocking the transmit path with a local reference clock, the receive interface may also be configured to present data relative to a recovered clock or to a local reference clock.

Each transmit and receive channel contains an independent BIST pattern generator and checker. This BIST hardware allows at-speed testing of the high-speed serial data paths in each transmit and receive section, and across the interconnecting links.

The CYP(V)(W)15G0403DXB is ideal for port applications where different data rates and serial interface standards are necessary for each channel. Some applications include multi-protocol routers, aggregation equipment, and switches.

CYP(V)(W)15G0403DXB Transceiver Logic Block Diagram

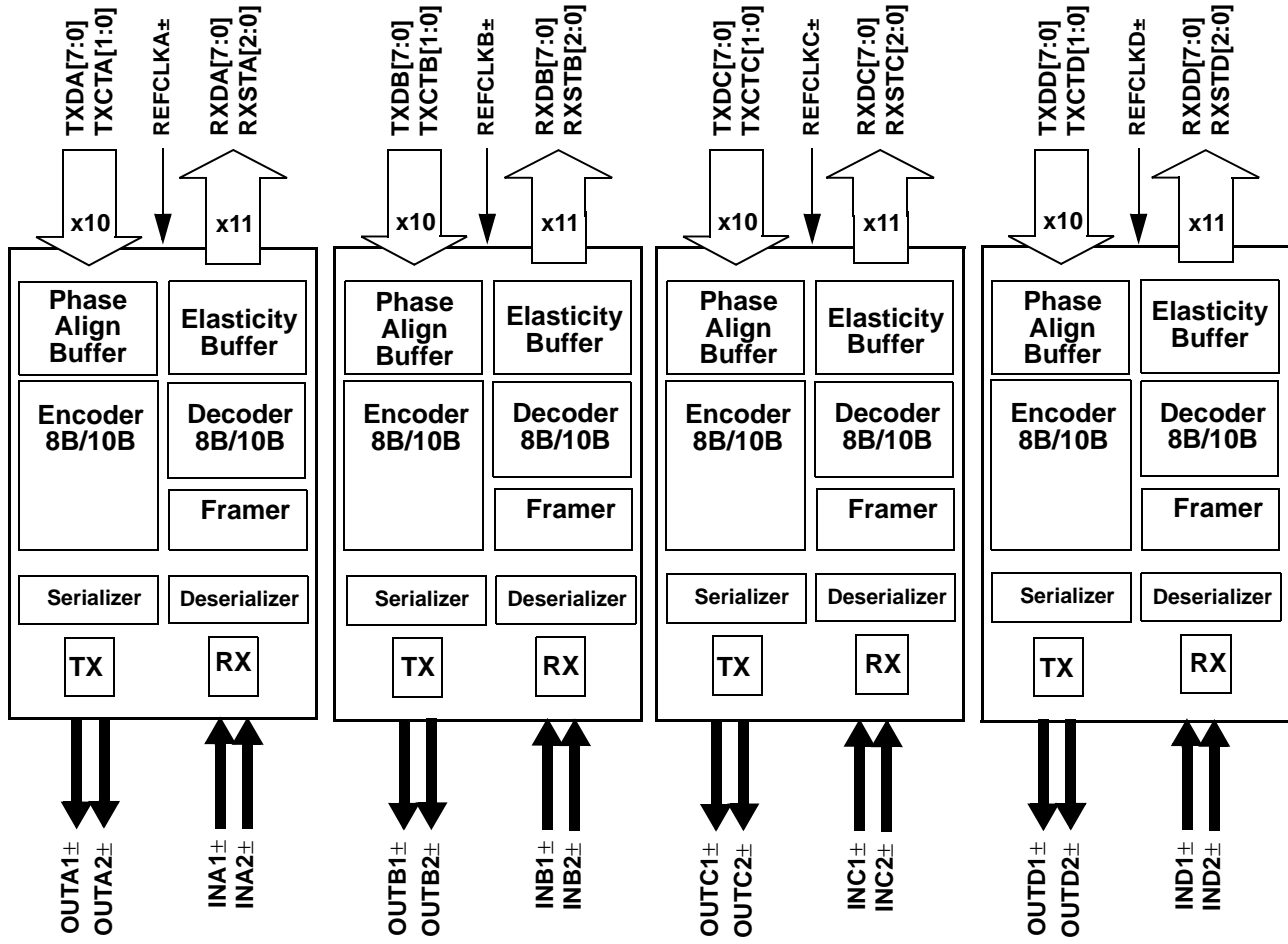

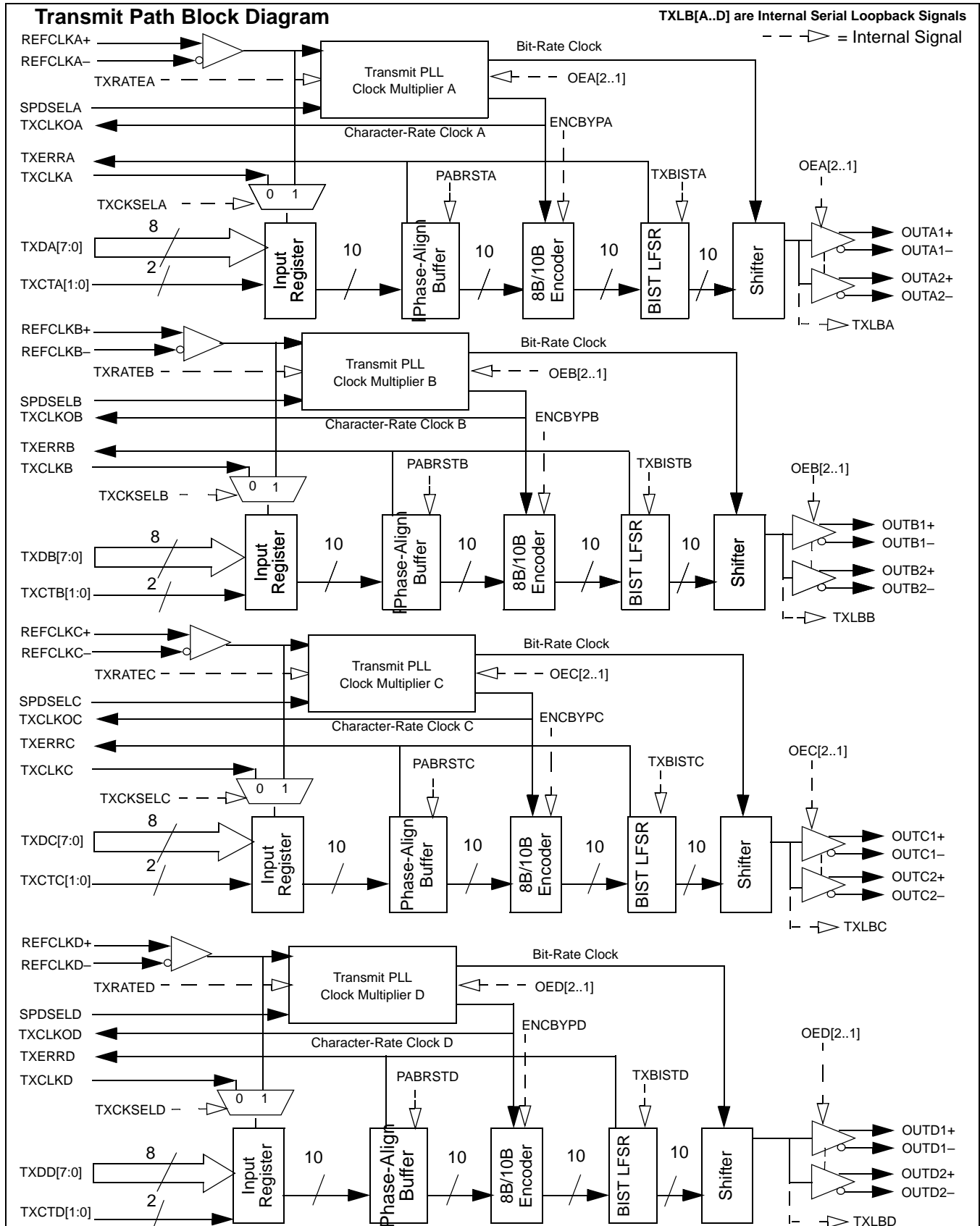

Receive Path Block Diagram

TXLB[A..D] are Internal Serial Loopback Signals
 - - ▷ = Internal Signal

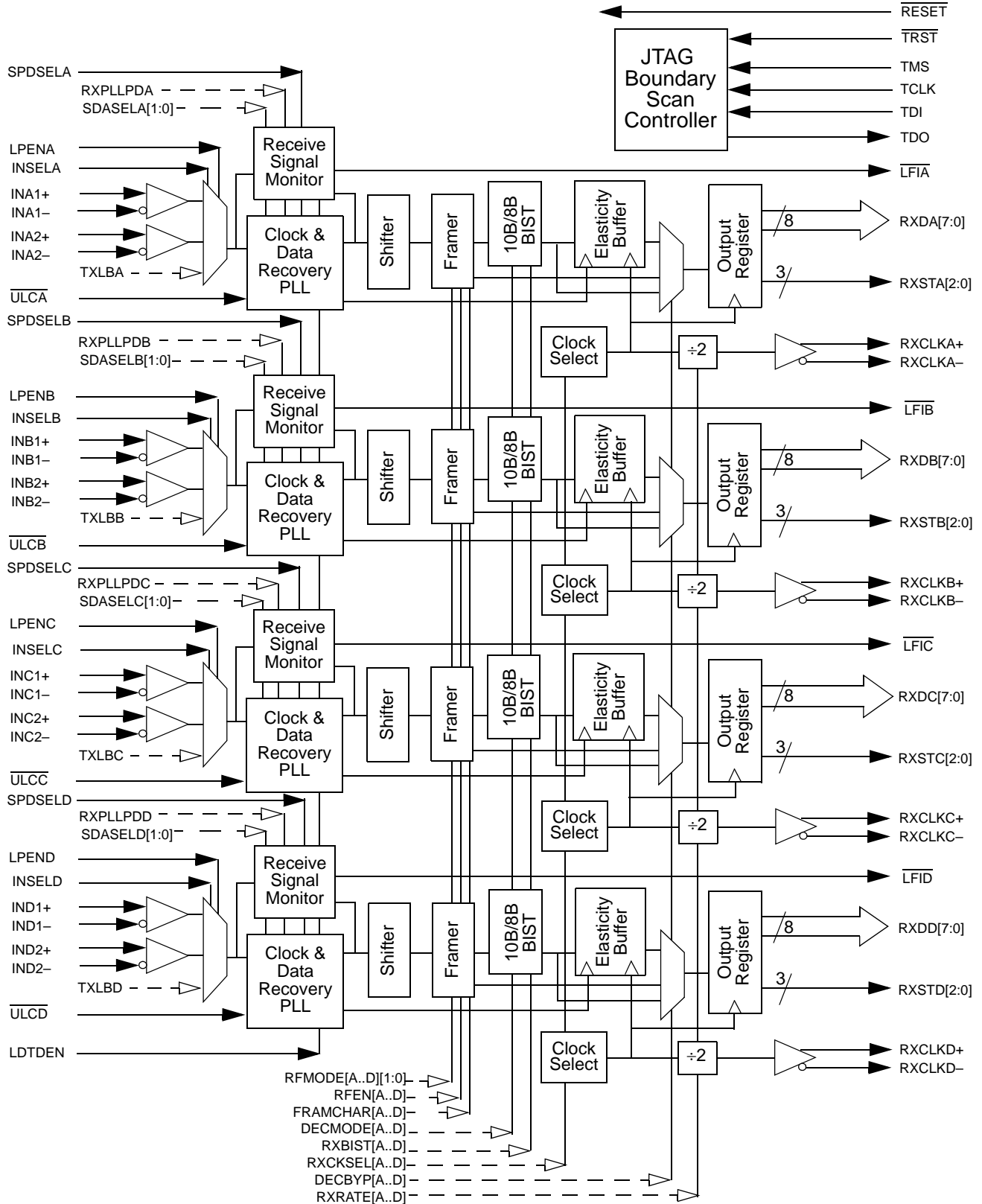

Device Configuration and Control Block Diagram

--▷ = Internal Signal

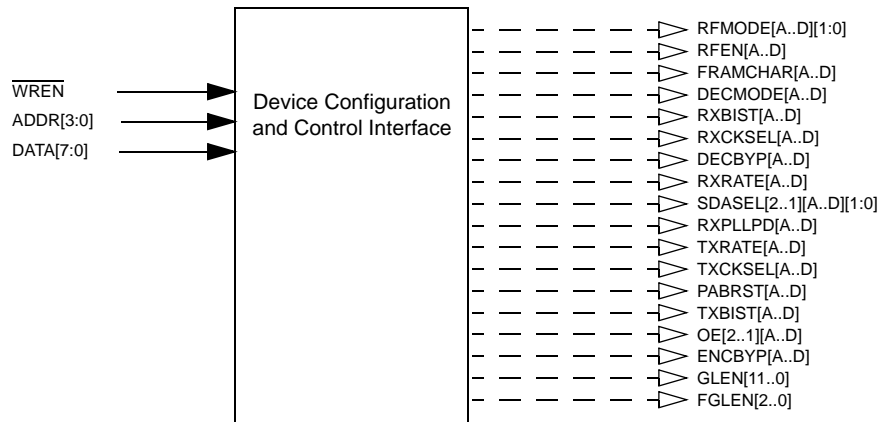

Pin Configuration (Top View)

	1	2	3	4	5	6	7	8	9	10	11	12	13	14	15	16	17	18	19	20
A	IN C1-	OUT C1-	IN C2-	OUT C2-	V _{CC}	IN D1-	OUT D1-	GND	IN D2-	OUT D2-	IN A1-	OUT A1-	GND	IN A2-	OUT A2-	V _{CC}	IN B1-	OUT B1-	IN B2-	OUT B2-
B	IN C1+	OUT C1+	IN C2+	OUT C2+	V _{CC}	IN D1+	OUT D1+	GND	IN D2+	OUT D2+	IN A1+	OUT A1+	GND	IN A2+	OUT A2+	V _{CC}	IN B1+	OUT B1+	IN B2+	OUT B2+
C	TDI	TMS	INSEL C	INSEL B	V _{CC}	ULC _D	ULC _C	GND	DATA [7]	DATA [5]	DATA [3]	DATA [1]	GND	NC	SPD SELD	V _{CC}	LDTD EN	TRST	LPEND	TDO
D	TCLK	RESET	INSEL D	INSEL A	V _{CC}	ULC _A	SPD SELC	GND	DATA [6]	DATA [4]	DATA [2]	DATA [0]	GND	LPENB	ULC _B	V _{CC}	LPENA	LTEN1	SCAN EN2	TMEN3
E	V _{CC}	V _{CC}	V _{CC}	V _{CC}													V _{CC}	V _{CC}	V _{CC}	V _{CC}
F	RX DC[6]	RX DC[7]	TX DC[0]	NC													NC	RX STB[1]	TX CLKOB	RX STB[0]
G	TX DC[7]	WREN	TX DC[4]	TX DC[1]													SPD SELB	LP ENC	SPD SELA	RX DC[1]
H	GND	GND	GND	GND													GND	GND	GND	GND
J	TX CTC[1]	TX DC[5]	TX DC[2]	TX DC[3]													RX STB[2]	RX DB[0]	RX DB[5]	RX DB[2]
K	RX DC[2]	REF CLKC-	TX CTC[0]	TX CLKC													RX DB[3]	RX DB[4]	RX DB[7]	LFB
L	RX DC[3]	REF CLKC+	LFC	TX DC[6]													RX DB[6]	RX CLKB+	RX CLKB-	TX DB[6]
M	RX DC[4]	RX DC[5]	NC	TX ERR C													REF CLKB+	REF CLKB-	TX ERR B	TX CLKB
N	GND	GND	GND	GND													GND	GND	GND	GND
P	RX DC[1]	RX DC[0]	RX STC[0]	RX STC[1]													TX DB[5]	TX DB[4]	TX DB[3]	TX DB[2]
R	RX STC[2]	TX CLKOC	RX CLKC+	RX CLKC-													TX DB[1]	TX DB[0]	TX CTB[1]	TX DB[7]
T	V _{CC}	V _{CC}	V _{CC}	V _{CC}													V _{CC}	V _{CC}	V _{CC}	V _{CC}
U	TX DD[0]	TX DD[1]	TX DD[2]	TX CTD[1]	V _{CC}	RX DD[2]	RX DD[1]	GND	TX CTA[1]	ADDR [0]	REF CLKD-	TX DA[1]	GND	TX DA[4]	TX CTA[0]	V _{CC}	RX DA[2]	TX CTB[0]	RX STA[2]	RX STA[1]
V	TX DD[3]	TX DD[4]	TX CTD[0]	RX DD[6]	V _{CC}	RX DD[3]	RX STD[0]	GND	RX STD[2]	ADDR [2]	REF CLKD+	TX CLKOA	GND	TX DA[3]	TX DA[7]	V _{CC}	RX DA[7]	RX DA[3]	RX DA[0]	RX STA[0]
W	TX DD[5]	TX DD[7]	LFD	RX CLKD-	V _{CC}	RX DD[4]	RX STD[1]	GND	ADDR [3]	ADDR [1]	RX CLKA+	TX ERRA	GND	TX DA[2]	TX DA[6]	V _{CC}	LFA	REF CLKA+	RX DA[4]	RX DA[1]
Y	TX DD[6]	TX CLKD	RX DD[7]	RX CLKD+	V _{CC}	RX DD[5]	RX DD[0]	GND	TX CLKOD	NC	TX CLKA	RX CLKA-	GND	TX DA[0]	TX DA[5]	V _{CC}	TX ERRD	REF CLKA-	RX DA[6]	RX DA[5]

Pin Configuration (Bottom View)

	20	19	18	17	16	15	14	13	12	11	10	9	8	7	6	5	4	3	2	1
A	OUT B2-	IN B2-	OUT B1-	IN B1-	V _{CC}	OUT A2-	IN A2-	GND	OUT A1-	IN A1-	OUT D2-	IN D2-	GND	OUT D1-	IN D1-	V _{CC}	OUT C2-	IN C2-	OUT C1-	IN C1-
B	OUT B2+	IN B2+	OUT B1+	IN B1+	V _{CC}	OUT A2+	IN A2+	GND	OUT A1+	IN A1+	OUT D2+	IN D2+	GND	OUT D1+	IN D1+	V _{CC}	OUT C2+	IN C2+	OUT C1+	IN C1+
C	TDO	LP END	TRST	LDTD EN	V _{CC}	SPD SELD	NC	GND	DATA [1]	DATA [3]	DATA [5]	DATA [7]	GND	ULCC	ULCD	V _{CC}	IN SELB	IN SELC	TMS	TDI
D	TMEN3	SCAN EN2	LTEN1	LP ENA	V _{CC}	ULCB	LP ENB	GND	DATA [0]	DATA [2]	DATA [4]	DATA [6]	GND	SPD SELC	ULCA	V _{CC}	IN SELA	IN SELD	RESET	TCLK
E	V _{CC}	V _{CC}	V _{CC}	V _{CC}													V _{CC}	V _{CC}	V _{CC}	V _{CC}
F	RX STB[0]	TX CLKOB	RX STB[1]	NC													NC	TX DC[0]	RX DC[7]	Rx DC[6]
G	RX DB[1]	SPD SELA	LP ENC	SPD SELB													TX DC[1]	TX DC[4]	WREN	TX DC[7]
H	GND	GND	GND	GND													GND	GND	GND	GND
J	RX DB[2]	RX DB[5]	RX DB[0]	RX STB[2]													TX DC[3]	TX DC[2]	TX DC[5]	TX CTC[1]
K	LFIB	RX DB[7]	RX DB[4]	RX DB[3]													TX CLKC	TX CTC[0]	REF CLKC-	RX DC[2]
L	TX DB[6]	RX CLKB-	RX CLKB+	RX DB[6]													TX DC[6]	LFIC	REF CLKC+	RX DC[3]
M	TX CLKB	TX ERRB	REF CLKB-	REF CLKB+													TX ERRC	NC	RX DC[5]	RX DC[4]
N	GND	GND	GND	GND													GND	GND	GND	GND
P	TX DB[2]	TX DB[3]	TX DB[4]	TX DB[5]													RX STC[1]	RX STC[0]	RX DC[0]	RX DC[1]
R	TX DB[7]	TX CTB[1]	TX DB[0]	TX DB[1]													RX CLKC-	RX CLKC+	TX CLKOC	RX STC[2]
T	V _{CC}	V _{CC}	V _{CC}	V _{CC}													V _{CC}	V _{CC}	V _{CC}	V _{CC}
U	RX STA[1]	RX STA[2]	TX CTB[0]	RX DA[2]	V _{CC}	TX CTA[0]	TX DA[4]	GND	TX DA[1]	REF CLKD-	ADDR [0]	TXC TA[1]	GND	RX DD[1]	RX DD[2]	V _{CC}	TX CTD[1]	TX DD[2]	TX DD[1]	TX DD[0]
V	RX STA[0]	RX DA[0]	RX DA[3]	RX DA[7]	V _{CC}	TX DA[7]	TX DA[3]	GND	TX CLKOA	REF CLKD+	ADDR [2]	RX STD[2]	GND	RX STD[0]	RX DD[3]	V _{CC}	RX DD[6]	TX CTD[0]	TX DD[4]	TX DD[3]
W	RX DA[1]	RX DA[4]	REF CLKA+	LFIA	V _{CC}	TX DA[6]	TX DA[2]	GND	TX ERRA	RX CLKA+	ADDR [1]	ADDR [3]	GND	RX STD[1]	RX DD[4]	V _{CC}	RX CLKD-	LFID	TX DD[7]	TX DD[5]
Y	RX DA[5]	RX DA[6]	REF CLKA-	TX ERRD	V _{CC}	TX DA[5]	TX DA[0]	GND	RX CLKA-	TX CLKA	NC	TX CLKOD	GND	RX DD[0]	RX DD[5]	V _{CC}	RX CLKD+	RX DD[7]	TX CLKD	TX DD[6]

Pin Descriptions
CYP(V)(W)15G0403DXB Quad HOTLink II Transceiver

Name	I/O Characteristics	Signal Description
Transmit Path Data and Status Signals		
TXDA[7:0] TXDB[7:0] TXDC[7:0] TXDD[7:0]	LVTTTL Input, synchronous, sampled by the associated TXCLKx [↑] or REFCLKx [↑] [2]	Transmit Data Inputs. TXDx[7:0] data inputs are captured on the rising edge of the transmit interface clock. The transmit interface clock is selected by the TXCKSELx latch via the device configuration interface, and passed to the encoder or Transmit Shifter. When the Encoder is enabled, TXDx[7:0] specifies the specific data or command character sent.
TXCTA[1:0] TXCTB[1:0] TXCTC[1:0] TXCTD[1:0]	LVTTTL Input, synchronous, sampled by the associated TXCLKx [↑] or REFCLKx [↑] [2]	Transmit Control. TXCTx[1:0] inputs are captured on the rising edge of the transmit interface clock. The transmit interface clock is selected by the TXCKSELx latch via the device configuration interface, and passed to the Encoder or Transmit Shifter. The TXCTA[1:0] inputs identify how the associated TXDx[7:0] characters are interpreted. When the Encoder is bypassed, these inputs are interpreted as data bits. When the Encoder is enabled, these inputs determine if the TXDx[7:0] character is encoded as Data, a Special Character code, or replaced with other Special Character codes. See Table 3 on page 14 for details.
TXERRA TXERRB TXERRC TXERRD	LVTTTL Output, synchronous to REFCLKx [↑] [3], synchronous to RXCLKx when selected as REFCLKx, asynchronous to transmit channel enable / disable, asynchronous to loss or return of REFCLKx [±]	Transmit Path Error. TXERRx is asserted HIGH to indicate detection of a transmit Phase-Align Buffer underflow or overflow. If an underflow or overflow condition is detected, TXERRx, for the channel in error, is asserted HIGH and remains asserted until either a Word Sync Sequence is transmitted on that channel, or the transmit Phase-Align Buffer is re-centered with the PABRSTx latch via the device configuration interface. When TXBISTx = 0, the BIST progress is presented on the associated TXERRx output. The TXERRx signal pulses HIGH for one transmit-character clock period to indicate a pass through the BIST sequence once every 511 or 527 (depending on RXCKSELx) character times. If RXCKSELx = 1, a one character pulse occurs every 527 character times. If RXCKSELx = 0, a one character pulse occurs every 511 character times. TXERRx is also asserted HIGH, when any of the following conditions is true: <ul style="list-style-type: none"> • The TXPLL for the associated channel is powered down. This occurs when OE2x and OE1x for a given channel are both disabled by setting OE2x = 0 and OE1x = 0. • The absence of the REFCLKx[±] signal
Transmit Path Clock Signals		
REFCLKA [±] REFCLKB [±] REFCLKC [±] REFCLKD [±]	Differential LVPECL or single-ended LVTTTL input clock	Reference Clock. REFCLKx [±] clock inputs are used as the timing references for the transmit and receive PLLs. These input clocks may also be selected to clock the transmit and receive parallel interfaces. When driven by a single-ended LVCMOS or LVTTTL clock source, connect the clock source to either the true or complement REFCLKx input, and leave the alternate REFCLKx input open (floating). When driven by an LVPECL clock source, the clock must be a differential clock, using both inputs.
TXCLKA TXCLKB TXCLKC TXCLKD	LVTTTL Clock Input, internal pull-down	Transmit Path Input Clock. When configuration latch TXCKSELx = 0, the associated TXCLKx input is selected as the character-rate input clock for the TXDx[7:0] and TXCTx[1:0] inputs. In this mode, the TXCLKx input must be frequency-coherent to its associated TXCLKOx output clock, but may be offset in phase by any amount. Once initialized, TXCLKx is allowed to drift in phase as much as ±180 degrees. If the input phase of TXCLKx drifts beyond the handling capacity of the Phase Align Buffer, TXERRx is asserted to indicate the loss of data, and remains asserted until the Phase Align Buffer is initialized. The phase of the TXCLKx input clock relative to its associated REFCLKx [±] is initialized when the configuration latch PABRSTx is written as 0. When the associated TXERRx is deasserted, the Phase Align Buffer is initialized and input characters are correctly captured.

Notes

2. When REFCLKx[±] is configured for half-rate operation, these inputs are sampled relative to both the rising and falling edges of the associated REFCLKx[±].
3. When REFCLKx[±] is configured for half-rate operation, these outputs are presented relative to both the rising and falling edges of the associated REFCLKx[±].

Pin Descriptions (continued)
CYP(V)(W)15G0403DXB Quad HOTLink II Transceiver

Name	I/O Characteristics	Signal Description
TXCLKOA TXCLKOB TXCLKOC TXCLKOD	LVTTL Output	Transmit Clock Output. TXCLKOx output clock is synthesized by each channel's transmit PLL and operates synchronous to the internal transmit character clock. TXCLKOx operates at either the same frequency as REFCLKx± (TXRATEx = 0), or at twice the frequency of REFCLKx± (TXRATEx = 1). The transmit clock outputs have no fixed phase relationship to REFCLKx±.
Receive Path Data and Status Signals		
RXDA[7:0] RXDB[7:0] RXDC[7:0] RXDD[7:0]	LVTTL Output, synchronous to the selected RXCLK± output or REFCLKx± input	Parallel Data Output. RXDx[7:0] parallel data outputs change relative to the receive interface clock. The receive interface clock is selected by the RXCKSELx latch. If RXCLKx± is a full-rate clock, the RXCLKx± clock outputs are complementary clocks operating at the character rate. The RXDx[7:0] outputs for the associated receive channels follow rising edge of RXCLKx+ or falling edge of RXCLKx-. If RXCLKx± is a half-rate clock, the RXCLKx± clock outputs are complementary clocks operating at half the character rate. The RXDx[7:0] outputs for the associated receive channels follow both the falling and rising edges of the associated RXCLKx± clock outputs.
RXSTA[2:0] RXSTB[2:0] RXSTC[2:0] RXSTD[2:0]	LVTTL Output, synchronous to the selected RXCLK± output or REFCLKx± input	Parallel Status Output. RXSTA[2:0] status outputs change relative to the receive interface clock. The receive interface clock is selected by the RXCKSELx latch. If RXCLKx± is a full-rate clock, the RXCLKx± clock outputs are complementary clocks operating at the character rate. The RXSTAx[2:0] outputs for the associated receive channels follow rising edge of RXCLKx+ or falling edge of RXCLKx-. If RXCLKx± is a half-rate clock, the RXCLKx± clock outputs are complementary clocks operating at half the character rate. The RXSTAx[2:0] outputs for the associated receive channels follow both the falling and rising edges of the associated RXCLKx± clock outputs. When the decoder is bypassed, RXSTx[1:0] become the two low-order bits of the 10-bit received character. RXSTx[2] = HIGH indicates the presence of a Comma character in the Output Register. When the decoder is enabled, RXSTx[2:0] provide status of the received signal. See Table 11 on page 25 for a list of received character status.
Receive Path Clock Signals		
RXCLKA± RXCLKB± RXCLKC± RXCLKD±	LVTTL Output Clock	Receive Clock Output. RXCLKx± is the receive interface clock used to control timing of the RXDx[7:0] and RXSTA[2:0] parallel outputs. The source of the RXCLKx± outputs is selected by the RXCKSELx latch via the device configuration interface. These true and complement clocks are used to control timing of data output transfers. These clocks are output continuously at either the dual-character rate (1/20 th the serial bit-rate) or character rate (1/10 th the serial bit-rate) of the data being received, as selected by RXRATEx. When configured such that the output data path is clocked by the REFCLKx± instead of a recovered clock, the RXCLKx± output drivers present a buffered or divided form (depending on RXRATEx) of the associated REFCLKx± that are delayed in phase to align with the data. This phase difference allows the user to select the optimal clock (REFCLKx± or RXCLK±) for setup/hold timing for their specific system. When REFCLKx± is a full-rate clock, the RXCLKx± rate depends on the value of RXRATEx. When REFCLKx± is a half-rate clock and RXCKSELx = 0, the RXCLKx± rate depends on the value of RXRATEx. When REFCLKx± is a half-rate clock and RXCKSELx=1, the RXCLKx± rate does not depend on the value of RXRATEx and operates at the same rate as REFCLKx±.

Pin Descriptions (continued)
CYP(V)(W)15G0403DXB Quad HOTLink II Transceiver

Name	I/O Characteristics	Signal Description
Device Control Signals		
RESET	LVTTTL Input, asynchronous, internal pull-up	Asynchronous Device Reset. RESET initializes all state machines, counters, and configuration latches in the device to a known state. RESET must be asserted LOW for a minimum pulse width. When the reset is removed, all state machines, counters and configuration latches are at an initial state. As per the JTAG specifications the device RESET cannot reset the JTAG controller. Therefore, the JTAG controller has to be reset separately. Refer to "JTAG Support" on page 24 for the methods to reset the JTAG state machine. See Table 9 on page 20 for the initialize values of the device configuration latches.
LDTDEN	LVTTTL Input, internal pull-up	Level Detect Transition Density Enable. When LDTDEN is HIGH, the Signal Level Detector, Range Controller, and Transition Density Detector are all enabled to determine if the RXPLL tracks REFCLKx± or the selected input serial data stream. If the Signal Level Detector, Range Controller, or Transition Density Detector are out of their respective limits while LDTDEN is HIGH, the RXPLL locks to REFCLKx± until such a time they become valid. The (SDASEL[A..D][1:0]) are used to configure the trip level of the Signal Level Detector. The Transition Density Detector limit is one transition in every 60 consecutive bits. When LDTDEN is LOW, only the Range Controller is used to determine if the RXPLL tracks REFCLKx± or the selected input serial data stream. For the cases when RXCKSELx = 0 (recovered clock), it is recommended to set LDTDEN = HIGH.
ULCA ULCB ULCC ULCD	LVTTTL Input, internal pull-up	Use Local Clock. When ULCx is LOW, the RXPLL is forced to lock to REFCLKx± instead of the received serial data stream. While ULCx is LOW, the LFIx for the associated channel is LOW indicating a link fault. When ULCx is HIGH, the RXPLL performs Clock and Data Recovery functions on the input data streams. This function is used in applications in which a stable RXCLKx± is needed. In cases when there is an absence of valid data transitions for a long period of time, or the high-gain differential serial inputs (INx±) are left floating, there may be brief frequency excursions of the RXCLKx± outputs from REFCLKx±.
SPDSELA SPDSELB SPDSELC SPDSELD	3-Level Select ^[4] static control input	Serial Rate Select. The SPDSELx inputs specify the operating signaling-rate range of each channel's transmit and receive PLL. LOW = 195 – 400 MBaud MID = 400 – 800 MBaud HIGH = 800 – 1500 MBaud (800–1540 MBaud for CYW15G0403DXB)
INSELA INSELB INSELC INSELD	LVTTTL Input, asynchronous	Receive Input Selector. The INSELx input determines which external serial bit stream is passed to the receiver's Clock and Data Recovery circuit. When INSELx is HIGH, the Primary Differential Serial Data Input, INx1±, is selected for the associated receive channel. When INSELx is LOW, the Secondary Differential Serial Data Input, INx2±, is selected for the associated receive channel.
LPENA LPENB LPENC LPEND	LVTTTL Input, asynchronous, internal pull-down	Loop-Back-Enable. The LPENx input enables the internal serial loop-back for the associated channel. When LPENx is HIGH, the transmit serial data from the associated channel is internally routed to the associated receive Clock and Data Recovery (CDR) circuit. All enabled serial drivers on the channel are forced to differential logic-1, and the serial data inputs are ignored. When LPENx is LOW, the internal serial loop-back function is disabled.

Note

4. 3-Level Select inputs are used for static configuration. These are ternary inputs that make use of logic levels of LOW, MID, and HIGH. The LOW level is usually implemented by direct connection to V_{SS} (ground). The HIGH level is usually implemented by direct connection to V_{CC} (power). The MID level is usually implemented by not connecting the input (left floating), which allows it to self bias to the proper level.

Pin Descriptions (continued)
CYP(V)(W)15G0403DXB Quad HOTLink II Transceiver

Name	I/O Characteristics	Signal Description
$\overline{\text{LFIA}}$ $\overline{\text{LFIB}}$ $\overline{\text{LFIC}}$ $\overline{\text{LFID}}$	LVTTTL Output, asynchronous	Link Fault Indication Output. $\overline{\text{LFIx}}$ is an output status indicator signal. $\overline{\text{LFIx}}$ is the logical OR of six internal conditions. $\overline{\text{LFIx}}$ is asserted LOW when any of the following conditions is true: <ul style="list-style-type: none"> • Received serial data rate outside expected range • Analog amplitude below expected levels • Transition density lower than expected • Receive channel disabled • $\overline{\text{ULC}}_x$ is LOW • Absence of $\overline{\text{REFCLK}}_{x\pm}$.
Device Configuration and Control Bus Signals		
$\overline{\text{WREN}}$	LVTTTL input, asynchronous, internal pull-up	Control Write Enable. The $\overline{\text{WREN}}$ input writes the values of the $\text{DATA}[7:0]$ bus into the latch specified by the address location on the $\text{ADDR}[3:0]$ bus. ^[5]
$\text{ADDR}[3:0]$	LVTTTL input asynchronous, internal pull-up	Control Addressing Bus. The $\text{ADDR}[3:0]$ bus is the input address bus used to configure the device. The $\overline{\text{WREN}}$ input writes the values of the $\text{DATA}[7:0]$ bus into the latch specified by the address location on the $\text{ADDR}[3:0]$ bus. ^[5] Table 9 on page 20 lists the configuration latches within the device, and the initialization value of the latches upon the assertion of $\overline{\text{RESET}}$. Table 10 on page 24 shows how the latches are mapped in the device.
$\text{DATA}[7:0]$	LVTTTL input asynchronous, internal pull-up	Control Data Bus. The $\text{DATA}[7:0]$ bus is the input data bus used to configure the device. The $\overline{\text{WREN}}$ input writes the values of the $\text{DATA}[7:0]$ bus into the latch specified by address location on the $\text{ADDR}[3:0]$ bus. ^[5] Table 9 lists the configuration latches within the device, and the initialization value of the latches upon the assertion of $\overline{\text{RESET}}$. Table 10 shows how the latches are mapped in the device.
Internal Device Configuration Latches		
$\text{RFMODE}[\text{A..D}][1:0]$	Internal Latch ^[6]	Reframe Mode Select.
$\text{FRAMCHAR}[\text{A..D}]$	Internal Latch ^[6]	Framing Character Select.
$\text{DECMODE}[\text{A..D}]$	Internal Latch ^[6]	Receiver Decoder Mode Select.
$\text{DECBYP}[\text{A..D}]$	Internal Latch ^[6]	Receiver Decoder Bypass.
$\text{RXCKSEL}[\text{A..D}]$	Internal Latch ^[6]	Receive Clock Select.
$\text{RXRATE}[\text{A..D}]$	Internal Latch ^[6]	Receive Clock Rate Select.
$\text{SDASEL}[\text{A..D}][1:0]$	Internal Latch ^[6]	Signal Detect Amplitude Select.
$\text{ENCBYP}[\text{A..D}]$	Internal Latch ^[6]	Transmit Encoder Bypassed.
$\text{TXCKSEL}[\text{A..D}]$	Internal Latch ^[6]	Transmit Clock Select.
$\text{TXRATE}[\text{A..D}]$	Internal Latch ^[6]	Transmit PLL Clock Rate Select.
$\text{RFEN}[\text{A..D}]$	Internal Latch ^[6]	Reframe Enable.
$\text{RXPLLPD}[\text{A..D}]$	Internal Latch ^[6]	Receive Channel Power Control.
$\text{RXBIST}[\text{A..D}]$	Internal Latch ^[6]	Receive Bist Disabled.
$\text{TXBIST}[\text{A..D}]$	Internal Latch ^[6]	Transmit Bist Disabled.
$\text{OE2}[\text{A..D}]$	Internal Latch ^[6]	Differential Serial Output Driver 2 Enable.
$\text{OE1}[\text{A..D}]$	Internal Latch ^[6]	Differential Serial Output Driver 1 Enable.

Notes

5. See "Device Configuration and Control Interface" on page 20 for detailed information on the operation of the Configuration Interface.
6. See "Device Configuration and Control Interface" on page 20 for detailed information on the internal latches.

Pin Descriptions (continued)
CYP(V)(W)15G0403DXB Quad HOTLink II Transceiver

Name	I/O Characteristics	Signal Description
PABRST[A..D]	Internal Latch ^[6]	Transmit Clock Phase Alignment Buffer Reset.
GLEN[11..0]	Internal Latch ^[6]	Global Latch Enable.
FGLEN[2..0]	Internal Latch ^[6]	Force Global Latch Enable.
Factory Test Modes		
LTEN1	LVTTTL input, internal pull-down	Factory Test 1. LTEN1 input is for factory testing only. This input may be left as a NO CONNECT, or GND only.
SCANEN2	LVTTTL input, internal pull-down	Factory Test 2. SCANEN2 input is for factory testing only. This input may be left as a NO CONNECT, or GND only.
TMEN3	LVTTTL input, internal pull-down	Factory Test 3. TMEN3 input is for factory testing only. This input may be left as a NO CONNECT, or GND only.
Analog I/O		
OUTA1± OUTB1± OUTC1± OUTD1±	CML Differential Output	Primary Differential Serial Data Output. The OUTx1± PECL-compatible CML outputs (+3.3V referenced) are capable of driving terminated transmission lines or standard fiber-optic transmitter modules, and must be AC-coupled for PECL-compatible connections.
OUTA2± OUTB2± OUTC2± OUTD2±	CML Differential Output	Secondary Differential Serial Data Output. The OUTx2± PECL-compatible CML outputs (+3.3V referenced) are capable of driving terminated transmission lines or standard fiber-optic transmitter modules, and must be AC-coupled for PECL-compatible connections.
INA1± INB1± INC1± IND1±	Differential Input	Primary Differential Serial Data Input. The INx1± input accepts the serial data stream for deserialization and decoding. The INx1± serial stream is passed to the receive CDR circuit to extract the data content when INSELx = HIGH.
INA2± INB2± INC2± IND2±	Differential Input	Secondary Differential Serial Data Input. The INx2± input accepts the serial data stream for deserialization and decoding. The INx2± serial stream is passed to the receiver CDR circuit to extract the data content when INSELx = LOW.
JTAG Interface		
TMS	LVTTTL Input, internal pull-up	Test Mode Select. Used to control access to the JTAG Test Modes. If maintained high for ≥5 TCLK cycles, the JTAG test controller is reset.
TCLK	LVTTTL Input, internal pull-down	JTAG Test Clock.
TDO	3-State LVTTTL Output	Test Data Out. JTAG data output buffer. High-Z while JTAG test mode is not selected.
TDI	LVTTTL Input, internal pull-up	Test Data In. JTAG data input port.
TRST	LVTTTL Input, internal pull-up	JTAG reset signal. When asserted (LOW), this input asynchronously resets the JTAG test access port controller.
Power		
V _{CC}		+3.3V Power.
GND		Signal and Power Ground for all internal circuits.

CYP(V)(W)15G0403DXB HOTLink II Operation

The CYP(V)(W)15G0403DXB is a highly configurable, independent clocking, quad-channel transceiver designed to support reliable transfer of large quantities of data, using high-speed serial links from multiple sources to multiple destinations. This device supports four single-byte channels.

CYP(V)(W)15G0403DXB Transmit Data Path

Input Register

The bits in the Input Register for each channel support different assignments, based on if the input data is encoded or unencoded. These assignments are shown in Table 1.

When the ENCODER is enabled, each input register captures eight data bits and two control bits on each input clock cycle. When the Encoder is bypassed, the control bits are part of the pre-encoded 10-bit character.

When the Encoder is enabled, the TXCTx[1:0] bits are interpreted along with the associated TXDx[7:0] character to generate a specific 10-bit transmission character.

Phase-Align Buffer

Data from each Input Register is passed to the associated Phase-Align Buffer, when the TXDx[7:0] and TXCTx[1:0] input registers are clocked using TXCLKx_i (TXCKSELx = 0 and TXRATEx = 0). When the TXDx[7:0] and TXCTx[1:0] input registers are clocked using REFCLKx_± (TXCKSELx = 1) and REFCLKx_± is a full-rate clock, the associated Phase Alignment Buffer in the transmit path is bypassed. These buffers are used to absorb clock phase differences between the TXCLKx input clock and the internal character clock for that channel.

Once initialized, TXCLKx is allowed to drift in phase as much as ±180 degrees. If the input phase of TXCLKx drifts beyond the handling capacity of the Phase Align Buffer, TXERRx is asserted to indicate the loss of data, and remains asserted until the Phase Align Buffer is initialized. The phase of the TXCLKx relative to its associated internal character rate clock is initialized when the configuration latch PABRSTx is written as 0. When the associated TXERRx is deasserted, the Phase Align Buffer is initialized and input characters are correctly captured.

Table 1. Input Register Bit Assignments^[7]

Signal Name	Unencoded	Encoded
TXDx[0] (LSB)	DINx[0]	TXDx[0]
TXDx[1]	DINx[1]	TXDx[1]
TXDx[2]	DINx[2]	TXDx[2]
TXDx[3]	DINx[3]	TXDx[3]
TXDx[4]	DINx[4]	TXDx[4]
TXDx[5]	DINx[5]	TXDx[5]
TXDx[6]	DINx[6]	TXDx[6]
TXDx[7]	DINx[7]	TXDx[7]
TXCTx[0]	DINx[8]	TXCTx[0]
TXCTx[1] (MSB)	DINx[9]	TXCTx[1]

Note

7. LSB shifted out first.

If the phase offset, between the initialized location of the input clock and REFCLKx_i, exceeds the skew handling capabilities of the Phase-Align Buffer, an error is reported on that channel's TXERRx output. This output indicates an error continuously until the Phase-Align Buffer for that channel is reset. While the error remains active, the transmitter for that channel outputs a continuous C0.7 character to indicate to the remote receiver that an error condition is present in the link.

Each Phase-Align Buffer may be individually reset with minimal disruption of the serial data stream. When a Phase-Align Buffer error is present, the transmission of a Word Sync Sequence re-centers the Phase-Align Buffer and clears the error indication.

Note. K28.5 characters may be added or removed from the data stream during the Phase Align Buffer reset operation. When used with non-Cypress devices that require a complete 16-character Word Sync Sequence for proper receive Elasticity Buffer Operation, it is recommend that the Phase Alignment Buffer reset be followed by a Word Sync Sequence to ensure proper operation.

Encoder

Each character received from the Input Register or Phase-Align Buffer is passed to the Encoder logic. This block interprets each character and any associated control bits, and outputs a 10-bit transmission character.

Depending on the operational mode, the generated transmission character may be

- the 10-bit pre-encoded character accepted in the Input Register.
- the 10-bit equivalent of the 8-bit Data character accepted in the Input Register.
- the 10-bit equivalent of the 8-bit Special Character code accepted in the Input Register.
- the 10-bit equivalent of the C0.7 violation character if a Phase-Align Buffer overflow or underflow error is present.
- a character that is part of the 511-character BIST sequence.
- a K28.5 character generated as an individual character or as part of the 16-character Word Sync Sequence.

Data Encoding

Raw data, as received directly from the Transmit Input Register, is seldom in a form suitable for transmission across a serial link. The characters must usually be processed or transformed to guarantee

- a minimum transition density (to allow the receive PLL to extract a clock from the serial data stream).
- a DC-balance in the signaling (to prevent baseline wander).
- run-length limits in the serial data (to limit the bandwidth requirements of the serial link).
- the remote receiver a way of determining the correct character boundaries (framing).

When the Encoder is enabled (ENCBYPx = 1), the characters transmitted are converted from Data or Special Character codes to 10-bit transmission characters, using an integrated 8B/10B encoder. When directed to encode the character as a Special Character code, the encoder uses the Special

Character encoding rules listed in [Table 16 on page 43](#). When directed to encode the character as a Data character, it is encoded using the Data Character encoding rules in [Table 15 on page 39](#).

The 8B/10B encoder is standards compliant with ANSI/NCITS ASC X3.230-1994 Fibre Channel, IEEE 802.3z Gigabit Ethernet, the IBM® ESCON® and FICON™ channels, ETSI DVB-ASI, and ATM Forum standards for data transport.

Many of the Special Character codes listed in [Table 16](#) may be generated by more than one input character. The CYP(V)(W)15G0403DXB is designed to support two independent (but non-overlapping) Special Character code tables. This allows the CYP(V)(W)15G0403DXB to operate in mixed environments with other Cypress HOTLink devices using the enhanced Cypress command code set, and the reduced command sets of other non-Cypress devices. Even when used in an environment that normally uses non-Cypress Special Character codes, the selective use of Cypress command codes can permit operation where running disparity and error handling must be managed.

Following conversion of each input character from eight bits to a 10-bit transmission character, it is passed to the Transmit Shifter and is shifted out LSB first, as required by ANSI and IEEE standards for 8B/10B coded serial data streams.

Transmit Modes

Encoder Bypass

When the Encoder is bypassed, the character captured from the TXDx[7:0] and TXCTx[1:0] input register is passed directly to the transmit shifter without modification. With the encoder bypassed, the TXCTx[1:0] inputs are considered part of the data character and do not perform a control function that would otherwise modify the interpretation of the TXDx[7:0] bits. The bit usage and mapping of these control bits when the Encoder is bypassed is shown in [Table 2](#).

Table 2. Encoder Bypass Mode

Signal Name	Bus Weight	10B Name
TXDx[0] (LSB)	2 ⁰	a ^[7]
TXDx[1]	2 ¹	b
TXDx[2]	2 ²	c
TXDx[3]	2 ³	d
TXDx[4]	2 ⁴	e
TXDx[5]	2 ⁵	i
TXDx[6]	2 ⁶	f
TXDx[7]	2 ⁷	g
TXCTx[0]	2 ⁸	h
TXCTx[1] (MSB)	2 ⁹	j

When the encoder is enabled, the TXCTx[1:0] data control bits control the interpretation of the TXDx[7:0] bits and the characters generated by them. These bits are interpreted as listed in [Table 3](#).

Table 3. Transmit Modes

TXCTx[1]	TXCTx[0]	Characters Generated
0	0	Encoded data character
0	1	K28.5 fill character
1	0	Special character code
1	1	16-character Word Sync Sequence

Word Sync Sequence

When TXCTx[1:0] = 11, a 16-character sequence of K28.5 characters, known as a Word Sync Sequence, is generated on the associated channel. This sequence of K28.5 characters may start with either a positive or negative disparity K28.5 (as determined by the current running disparity and the 8B/10B coding rules). The disparity of the second and third K28.5 characters in this sequence are reversed from what normal 8B/10B coding rules would generate. The remaining K28.5 characters in the sequence follow all 8B/10B coding rules. The disparity of the generated K28.5 characters in this sequence follow a pattern of either $++---+---+---+---+---+---+---$ or $---++-+-+---+---+---$.

The generation of this sequence, once started, cannot be stopped until all 16 characters have been sent. The content of the associated input registers are ignored for the duration of this sequence. At the end of this sequence, if the TXCTx[1:0] = 11 condition is sampled again, the sequence restarts and remains uninterrupted for the following 15 character clocks.

Transmit BIST

Each transmit channel contains an internal pattern generator that can be used to validate both the link and device operation. These generators are enabled by the associated TXBISTx latch via the device configuration interface. When enabled, a register in the associated transmit channel becomes a signature pattern generator by logically converting to a Linear Feedback Shift Register (LFSR). This LFSR generates a 511-character (or 526-character) sequence that includes all Data and Special Character codes, including the explicit violation symbols. This provides a predictable yet pseudo-random sequence that can be matched to an identical LFSR in the attached Receiver(s).

A device reset ($\overline{\text{RESET}}$ sampled LOW) presets the BIST Enable Latches to disable BIST on all channels.

All data and data-control information present at the associated TXDx[7:0] and TXCTx[1:0] inputs are ignored when BIST is active on that channel. If the receive channels are configured for reference clock operation, each pass is preceded by a 16-character Word Sync Sequence to allow Elasticity Buffer alignment and management of clock-frequency variations.

Transmit PLL Clock Multiplier

Each Transmit PLL Clock Multiplier accepts a character-rate or half-character-rate external clock at the associated REFCLKx± input, and that clock is multiplied by 10 or 20 (as selected by TXRATEx) to generate a bit-rate clock for use by the transmit shifter. It also provides a character-rate clock used by the transmit paths, and outputs this character rate clock as TXCLKOx.

Each clock multiplier PLL can accept a REFCLKx± input between 19.5 MHz and 150 MHz (19.5 MHz and 154 MHz for CYW15G0403DXB), however, this clock range is limited by the operating mode of the CYP(V)(W)15G0403DXB clock multiplier (TXRATEx) and by the level on the associated SPDSELx input.

SPDSELx are 3-level select^[4] inputs that select one of three operating ranges for the serial data outputs and inputs of the associated channel. The operating serial signaling-rate and allowable range of REFCLKx± frequencies are listed in Table 4.

Table 4. Operating Speed Settings

SPDSELx	TXRATE	REFCLKx± Frequency (MHz)	Signaling Rate (MBaud)
LOW	1	reserved	195–400
	0	19.5–40	
MID (Open)	1	20–40	400–800
	0	40–80	
HIGH	1	40–75	800–1500 (800–1540 for CYW15G0403DXB)
	0	80–150	

The REFCLKx± inputs are differential inputs with each input internally biased to 1.4V. If the REFCLKx+ input is connected to a TTL, LVTTTL, or LVCMOS clock source, the input signal is recognized when it passes through the internally biased reference point. When driven by a single-ended TTL, LVTTTL, or LVCMOS clock source, connect the clock source to either the true or complement REFCLKx input, and leave the alternate REFCLKx input open (floating).

When both the REFCLKx+ and REFCLKx– inputs are connected, the clock source must be a differential clock. This can either be a differential LVPECL clock that is DC- or AC-coupled or a differential LVTTTL or LVCMOS clock.

By connecting the REFCLKx– input to an external voltage source, it is possible to adjust the reference point of the REFCLKx+ input for alternate logic levels. When doing so it is necessary to ensure that the input differential crossing point remains within the parametric range supported by the input.

Serial Output Drivers

The serial output interface drivers use differential Current Mode Logic (CML) drivers to provide source-matched drivers for transmission lines. These drivers accept data from the Transmit Shifters. These drivers have signal swings equivalent to that of standard PECL drivers, and are capable of driving AC-coupled optical modules or transmission lines. When configured for local loopback (LPENx = HIGH), all enabled serial drivers are configured to drive a static differential logic 1. To achieve OBSAI RP3 compliancy, the serial output drivers must be AC-coupled to the transmission medium.

Transmit Channels Enabled

Each driver can be enabled or disabled separately via the device configuration interface.

When a driver is disabled via the configuration interface, it is internally powered down to reduce device power. If both serial drivers for a channel are in this disabled state, the associated internal logic for that channel is also powered down. A device reset (RESET sampled LOW) disables all output drivers.

Note. When a disabled transmit channel (i.e., both outputs disabled) is re-enabled:

- data on the serial outputs may not meet all timing specifications for up to 250 μs
- the state of the phase-align buffer cannot be guaranteed, and a phase-align reset is required if the phase-align buffer is used

CYP(V)(W)15G0403DXB Receive Data Path

Serial Line Receivers

Two differential Line Receivers, INx1± and INx2±, are available on each channel for accepting serial data streams. The active Serial Line Receiver on a channel is selected using the associated INSELx input. The Serial Line Receiver inputs are differential, and can accommodate wire interconnect and filtering losses or transmission line attenuation greater than 16 dB. For normal operation, these inputs should receive a signal of at least V_{DIFF} > 100 mV, or 200 mV peak-to-peak differential. Each Line Receiver can be DC- or AC-coupled to +3.3V powered fiber-optic interface modules (any ECL/PECL family, not limited to 100K PECL) or AC-coupled to +5V powered optical modules. The common-mode tolerance of these line receivers accommodates a wide range of signal termination voltages. Each receiver provides internal DC-restoration, to the center of the receiver's common mode range, for AC-coupled signals.

The local internal loopback (LPENx) allows the serial transmit data outputs to be routed internally back to the Clock and Data Recovery circuit associated with each channel. When configured for local loopback, the associated transmit serial driver outputs are forced to output a differential logic-1. This prevents local diagnostic patterns from being broadcast to attached remote receivers.

Signal Detect/Link Fault

Each selected Line Receiver (i.e., that routed to the clock and data recovery PLL) is simultaneously monitored for

- analog amplitude above amplitude level selected by SDASELx
- transition density above the specified limit
- range controls report the received data stream inside normal frequency range (±1500 ppm^[30])
- receive channel enabled
- Presence of reference clock
- ULCx is not asserted.

All of these conditions must be valid for the Signal Detect block to indicate a valid signal is present. This status is presented on the LFix (Link Fault Indicator) output associated with each receive channel, which changes synchronous to the selected receive interface clock.

Analog Amplitude

While most signal monitors are based on fixed constants, the analog amplitude level detection is adjustable to allow operation with highly attenuated signals, or in high-noise environments. The analog amplitude level detection is set by the SDASELx latch via device configuration interface. The SDASELx latch sets the trip point for the detection of a valid signal at one of three levels, as listed in Table 5. This control input affects the analog monitors for all receive channels.

Table 5. Analog Amplitude Detect Valid Signal Levels^[8]

SDASEL	Typical Signal with Peak Amplitudes Above
00	Analog Signal Detector is disabled
01	140 mV p-p differential
10	280 mV p-p differential
11	420 mV p-p differential

The Analog Signal Detect monitors are active for the Line Receiver as selected by the associated INSELx input. When configured for local loopback, no input receivers are selected, and the LFIx output for each channel reports only the receive VCO frequency out-of-range and transition density status of the associated transmit signal. When local loopback is active, the associated Analog Signal Detect Monitor is disabled.

Transition Density

The Transition Detection logic checks for the absence of transitions spanning greater than six transmission characters (60 bits). If no transitions are present in the data received, the Detection logic for that channel asserts LFIx.

Range Controls

The CDR circuit includes logic to monitor the frequency of the PLL Voltage Controlled Oscillator (VCO) used to sample the incoming data stream. This logic ensures that the VCO operates at, or near the rate of the incoming data stream for two primary cases:

- when the incoming data stream resumes after a time in which it has been “missing.”
- when the incoming data stream is outside the acceptable signaling rate range.

To perform this function, the frequency of the RXPLL VCO is periodically compared to the frequency of the REFCLKx± input. If the VCO is running at a frequency beyond ±1500 ppm^[30] as defined by the REFCLKx± frequency, it is periodically forced to the correct frequency (as defined by REFCLKx±, SPDSELx, and TXRATEx) and then released in an attempt to lock to the input data stream.

The sampling and relock period of the Range Control is calculated as follows: RANGE_CONTROL_SAMPLING_PERIOD = (RECOVERED BYTE CLOCK PERIOD) * (4096).

During the time that the Range Control forces the RXPLL VCO to track REFCLKx±, the LFIx output is asserted LOW. After a valid serial data stream is applied, it may take up to one RANGE CONTROL SAMPLING PERIOD before the PLL

Note

8. The peak amplitudes listed in this table are for typical waveforms that have generally 3–4 transitions for every ten bits. In a worse case environment the signals may have a sine-wave appearance (highest transition density with repeating 0101...). Signal peak amplitudes levels within this environment type could increase the values in the table above by approximately 100 mV.

locks to the input data stream, after which $\overline{\text{LFIx}}$ should be HIGH.

Receive Channel Enabled

The CYP(V)(W)15G0403DXB contains four receive channels that can be independently enabled and disabled. Each channel can be enabled or disabled separately through the RXPLLDPx input latch as controlled by the device configuration interface. When the RXPLLDPx latch = 0, the associated PLL and analog circuitry of the channel is disabled. Any disabled channel indicates a constant link fault condition on the LFIx output. When RXPLLDPx = 1, the associated PLL and receive channel is enabled to receive and decode a serial stream.

Note. When a disabled receive channel is reenabled, the status of the associated LFIx output and data on the parallel outputs for the associated channel may be indeterminate for up to 2 ms.

Clock/Data Recovery

The extraction of a bit-rate clock and recovery of bits from each received serial stream is performed by a separate CDR block within each receive channel. The clock extraction function is performed by an integrated PLL that tracks the frequency of the transitions in the incoming bit stream and align the phase of the internal bit-rate clock to the transitions in the selected serial data stream.

Each CDR accepts a character-rate (bit-rate ÷ 10) or half-character-rate (bit-rate ÷ 20) reference clock from the associated REFCLKx± input. This REFCLKx± input is used to

- ensure that the VCO (within the CDR) is operating at the correct frequency (rather than a harmonic of the bit-rate)
- reduce PLL acquisition time
- limit unlocked frequency excursions of the CDR VCO when there is no input data present at the selected Serial Line Receiver.

Regardless of the type of signal present, the CDR attempts to recover a data stream from it. If the signalling rate of the recovered data stream is outside the limits set by the range control monitors, the CDR tracks REFCLKx± instead of the data stream. Once the CDR output (RXCLK±) frequency returns back close to REFCLKx± frequency, the CDR input is switched back to the input data stream. If no data is present at the selected line receiver, this switching behavior may result in brief RXCLK± frequency excursions from REFCLKx±. However, the validity of the input data stream is indicated by the LFIx output. The frequency of REFCLKx± is required to be within ±1500 ppm^[30] of the frequency of the clock that drives the REFCLKx± input of the remote transmitter to ensure a lock to the incoming data stream.

For systems using multiple or redundant connections, the $\overline{\text{LFIx}}$ output can be used to select an alternate data stream. When an LFIx indication is detected, external logic can toggle selection of the associated INx1± and INx2± input through the associated INSELx input. When a port switch takes place, it is necessary for the receive PLL for that channel to reacquire the

new serial stream and frame to the incoming character boundaries.

Deserializer/Framer

Each CDR circuit extracts bits from the associated serial data stream and clocks these bits into the Shifter/Framer at the bit-clock rate. When enabled, the Framer examines the data stream looking for one or more COMMA or K28.5 characters at all possible bit positions. The location of this character in the data stream is used to determine the character boundaries of all following characters.

Framing Character

The CYP(V)(W)15G0403DXB allows selection of different framing characters on each channel. Two combinations of framing characters are supported to meet the requirements of different interfaces. The selection of the framing character is made through the FRAMCHARx latches via the configuration interface.

The specific bit combinations of these framing characters are listed in [Table 6](#). When the specific bit combination of the selected framing character is detected by the framer, the boundaries of the characters present in the received data stream are known.

Table 6. Framing Character Selector

FRAMCHARx	Bits detected in framer	
	Character Name	Bits Detected
0	COMMA+ COMMA-	00111110XX ^[9] or 11000001XX
1	-K28.5 +K28.5	0011111010 or 1100000101

Framer

The framer on each channel operates in one of three different modes. Each framer may be enabled or disabled using the RFENx latches via the configuration interface. When the framer is disabled (RFENx = 0), no combination of received bits alters the frame information.

When the Low-Latency framer is selected (RFMODEx[1:0] = 00), the framer operates by stretching the recovered character clock until it aligns with the received character boundaries. In this mode the framer starts its alignment process on the first detection of the selected framing character. To reduce the impact on external circuits that use the recovered clock, the clock period is not stretched by more than two bit-periods in any one clock cycle. When operated with a character-rate output clock, the output of properly framed characters may be delayed by up to nine character-clock cycles from the detection of the selected framing character. When operated with a half-character-rate output clock, the output of properly framed characters may be delayed by up to 14 character-clock cycles from the detection of the framing character.

Note. When Receive BIST is enabled on a channel, the Low-Latency Framer must not be enabled. The BIST sequence contains an aliased K28.5 framing character, which

Note

⁹ The standard definition of a Comma contains only seven bits. However, since all valid Comma characters within the 8B/10B character set also have the eighth bit as an inversion of the seventh bit, the compare pattern is extended to a full eight bits to reduce the possibility of a framing error.

causes the Receiver to update its character boundaries incorrectly.

When RFMODEx[1:0] = 10, the Cypress-Mode Multi-Byte framer is selected. The required detection of multiple framing characters makes the associated link much more robust to incorrect framing due to aliased SYNC characters in the data stream. In this mode, the framer does not adjust the character clock boundary, but instead aligns the character to the already recovered character clock. This ensures that the recovered clock does not contain any significant phase changes or hops during normal operation or framing, and allows the recovered clock to be replicated and distributed to other external circuits or components using PLL-based clock distribution elements. In this framing mode the character boundaries are only adjusted if the selected framing character is detected at least twice within a span of 50 bits, with both instances on identical 10-bit character boundaries.

When RFMODEx[1:0] = 01, the Alternate-mode Multi-Byte Framer is enabled. Like the Cypress-mode Multi-Byte Framer, multiple framing characters must be detected before the character boundary is adjusted. In this mode, the data stream must contain a minimum of four of the selected framing characters, received as consecutive characters, on identical 10-bit boundaries, before character framing is adjusted.

10B/8B Decoder Block

The decoder logic block performs two primary functions:

- decoding the received transmission characters to Data and Special Character codes
- comparing generated BIST patterns with received characters to permit at-speed link and device testing.

The framed parallel output of each deserializer shifter is passed to its associated 10B/8B Decoder where, if the decoder is enabled, the input data is transformed from a 10-bit transmission character back to the original Data or Special Character code. This block uses the 10B/8B decoder patterns in [Table 15 on page 39](#) and [Table 16 on page 43](#). Received Special Code characters are decoded using [Table 16](#). Valid data characters are indicated by a 000b bit-combination on the associated RXSTx[2:0] status bits, and Special Character codes are indicated by a 001b bit-combination of these status outputs. Framing characters, Invalid patterns, disparity errors, and synchronization status are presented as alternate combinations of these status bits.

When DECBYPx = 0, the 10B/8B decoder is bypassed via the configuration interface. When bypassed, raw 10-bit characters are passed through the receiver and presented at the RXDx[7:0] and the RXSTA[1:0] outputs as 10-bit wide characters.

When the decoder is enabled by setting DECBYPx = 1 via the configuration interface, the 10-bit transmission characters are decoded using [Table 15](#) and [Table 16](#). Received Special characters are decoded using [Table 16](#). The columns used in [Table 16](#) are determined by the DECMODEx latch via the device configuration interface. When DECMODEx = 0 the ALTERNATE table is used and when DECMODEx = 1 the CYPRESS table is used.

Receive BIST Operation

The receiver channel contains an internal pattern checker that can be used to validate both device and link operation. These pattern checkers are enabled by the associated RXBISTx latch via the device configuration interface. When enabled, a register in the associated receive channel becomes a signature pattern generator and checker by logically converting to a Linear Feedback Shift Register (LFSR). This LFSR generates a 511-character or 526-character sequence that includes all Data and Special Character codes, including the explicit violation symbols. This provides a predictable yet pseudo-random sequence that can be matched to an identical LFSR in the attached Transmitter(s). When synchronized with the received data stream, the associated Receiver checks each character in the Decoder with each character generated by the LFSR and indicates compare errors and BIST status at the RXSTx[2:0] bits of the Output Register.

When BIST is first recognized as being enabled in the Receiver, the LFSR is preset to the BIST-loop start-code of D0.0. This code D0.0 is sent only once per BIST loop. The status of the BIST progress and any character mismatches are presented on the RXSTx[2:0] status outputs.

Code rule violations or running disparity errors that occur as part of the BIST loop do not cause an error indication. RXSTx[2:0] indicates 010b or 100b for one character period per BIST loop to indicate loop completion. This status can be used to check test pattern progress. These same status values are presented when the decoder is bypassed and BIST is enabled on a receive channel.

The specific status reported by the BIST state machine are listed in [Table 11 on page 25](#). These same codes are reported on the receive status outputs.

The specific patterns checked by each receiver are described in detail in the Cypress application note "HOTLink Built-In Self-Test." The sequence compared by the CYP(V)(W)15G0403DXB is identical to that in the CY7B933, CY7C924DX, and CYP(V)(W)15G0401DXB, allowing interoperable systems to be built when used at compatible serial signaling rates.

If the number of invalid characters received ever exceeds the number of valid characters by 16, the receive BIST state machine aborts the compare operations and resets the LFSR to the D0.0 state to look for the start of the BIST sequence again.

When the receive paths are configured for REFCLKx± operation, each pass must be preceded by a 16-character Word Sync Sequence to allow management of clock frequency variations.

The receive BIST state machine requires the characters to be correctly framed for it to detect the BIST sequence. If the Low Latency Framer is enabled, the Framer misaligns to an aliased SYNC character within the BIST sequence. If the Alternate Multi-Byte Framer is enabled and the Receiver outputs are clocked relative to a recovered clock, it is generally necessary to frame the receiver before BIST is enabled. If the receive outputs are clocked relative to REFCLKx±, the transmitter precedes every 511 character BIST sequence with a 16 character-character Word Sync Sequence.

A device reset ($\overline{\text{RESET}}$ sampled LOW) presets the BIST Enable Latches to disable BIST on all channels.

Receive Elasticity Buffer

Each receive channel contains an Elasticity Buffer that is designed to support multiple clocking modes. These buffers allow data to be read using a clock that is asynchronous in both frequency and phase from the Elasticity Buffer write clock, or to be read using a clock that is frequency coherent but with uncontrolled phase relative to the Elasticity Buffer write clock.

If the chip is configured for operation with a recovered clock, the Elasticity Buffer is bypassed.

Each Elasticity Buffer is 10 characters deep, and supports an 11 bit wide data path. It is capable of supporting a decoded character and three status bits for each character present in the buffer. The write clock for these buffers is always the recovered clock for the associated read channel.

Receive Modes

When the receive channel is clocked by REFCLKx±, the RXCLKx± outputs present a buffered or divided (depending on RXRATEx) and delayed form of REFCLKx±. In this mode, the receive Elasticity Buffers are enabled. For REFCLKx± clocking, the Elasticity Buffers must be able to insert K28.5 characters and delete framing characters as appropriate.

The insertion of a K28.5 or deletion of a framing character can occur at any time on any channel, however, the actual timing of these insertions and deletions is controlled in part by how the transmitter sends its data. Insertion of a K28.5 character can only occur when the receiver has a framing character in the Elasticity Buffer. Likewise, to delete a framing character, one must also be in the Elasticity Buffer. To prevent a buffer overflow or underflow on a receive channel, a minimum density of framing characters must be present in the received data streams.

When the receive channel Output Register is clocked by a recovered clock, no characters are added or deleted and the receiver Elasticity Buffer is bypassed.

Power Control

The CYP(V)(W)15G0403DXB supports user control of the powered up or down state of each transmit and receive channel. The receive channels are controlled by the RXPLLDPx latch via the device configuration interface. When RXPLLDPx = 0, the associated PLL and analog circuitry of the channel is disabled. The transmit channels are controlled by the OE1x and the OE2x latches via the device configuration interface. When a driver is disabled via the configuration interface, it is internally powered down to reduce device power. If both serial drivers for a channel are in this disabled state, the associated internal logic for that channel is also powered down.

Device Reset State

When the CYP(V)(W)15G0403DXB is reset by assertion of $\overline{\text{RESET}}$, all state machines, counters, and configuration latches in the device are initialized to a reset state, and the Elasticity Buffer pointers are set to a nominal offset. Additionally, the JTAG controller must also be reset to ensure valid operation (even if JTAG testing is not performed). See

“JTAG Support” on page 24 for JTAG state machine initialization. See Table 9 on page 20 for the initialize values of the configuration latches.

Following a device reset, it is necessary to enable the transmit and receive channels used for normal operation. This can be done by sequencing the appropriate values on the device configuration interface.^[5]

Output Bus

Each receive channel presents an 11-signal output bus consisting of

- an 8-bit data bus
- a 3-bit status bus.

The signals present on this output bus are modified by the present operating mode of the CYP(V)(W)15G0403DXB as selected by the DECBYPx configuration latch. This mapping is shown in Table 7.

Table 7. Output Register Bit Assignments

Signal Name	BYPASS ACTIVE (DECBYPx = 0)	DECODER (DECBYP = 1)
RXSTx[2] (LSB)	COMDET _x	RXSTx[2]
RXSTx[1]	DOUTx[0]	RXSTx[1]
RXSTx[0]	DOUTx[1]	RXSTx[0]
RXDx[0]	DOUTx[2]	RXDx[0]
RXDx[1]	DOUTx[3]	RXDx[1]
RXDx[2]	DOUTx[4]	RXDx[2]
RXDx[3]	DOUTx[5]	RXDx[3]
RXDx[4]	DOUTx[6]	RXDx[4]
RXDx[5]	DOUTx[7]	RXDx[5]
RXDx[6]	DOUTx[8]	RXDx[6]
RXDx[7] (MSB)	DOUTx[9]	RXDx[7]

When the 10B/8B decoder is bypassed, the framed 10-bit value is presented to the associated Output Register, along with a status output signal indicating if the character in the Output Register is one of the selected framing characters. The bit usage and mapping of the external signals to the raw 10B transmission character is shown in Table 8.

The COMDET_x status output operates the same regardless of the bit combination selected for character framing by the FRAMCHAR_x latch. COMDET_x is HIGH when the character in the output register contains the selected framing character at the proper character boundary, and LOW for all other bit combinations.

When the low-latency framer and half-rate receive port clocking are also enabled, the framer stretches the recovered clock to the nearest 20-bit boundary such that the rising edge of RXCLK_{x+} occurs when COMDET_x is present on the associated output bus.

When the Cypress or Alternate Mode Framer is enabled and half-rate receive port clocking is also enabled, the output clock is not modified when framing is detected, but a single pipeline stage may be added or subtracted from the data stream by the

Table 8. Decoder Bypass Mode

Signal Name	Bus Weight	10 Bit Name
RXSTx[2] (LSB)	COMDET _x	
RXSTx[1]	2 ⁰	a
RXSTx[0]	2 ¹	b
RXDx[0]	2 ²	c
RXDx[1]	2 ³	d
RXDx[2]	2 ⁴	e
RXDx[3]	2 ⁵	i
RXDx[4]	2 ⁶	f
RXDx[5]	2 ⁷	g
RXDx[6]	2 ⁸	h
RXDx[7] (MSB)	2 ⁹	j

framer logic such that the rising edge of RXCLK_{x+} occurs when COMDET_x is present on the associated output bus.

This adjustment only occurs when the framer is enabled. When the framer is disabled, the clock boundaries are not adjusted, and COMDET_x may be asserted during the rising edge of RXCLK_{x-} (if an odd number of characters were received following the initial framing).

Receive Status Bits

When the 10B/8B decoder is enabled, each character presented at the Output Register includes three associated status bits. These bits are used to identify

- if the contents of the data bus are valid,
- the type of character present,
- the state of receive BIST operations,
- character violations.

These conditions often overlap; e.g. a valid data character received with incorrect running disparity is not reported as a valid data character. It is instead reported as a decoder violation of some specific type. This implies a hierarchy or priority level to the various status bit combinations. The hierarchy and value of each status are listed in Table 11.

A second status mapping, listed in Table 11, is used when the receive channel is configured for BIST operation. This status is used to report receive BIST status and progress.

BIST Status State Machine

When a receive path is enabled to look for and compare the received data stream with the BIST pattern, the RXSTx[2:0] bits identify the present state of the BIST compare operation.

The BIST state machine has multiple states, as shown in Figure 2 and Table 11. When the receive PLL detects an out-of-lock condition, the BIST state is forced to the Start-of-BIST state, regardless of the present state of the BIST state machine. If the number of detected errors ever exceeds the number of valid matches by greater than 16, the state machine is forced to the WAIT_FOR_BIST state where it monitors the receive path for the first character of the next BIST sequence (D0.0). Also, if the Elasticity Buffer ever hits an overflow/underflow condition, the status is forced to the

BIST_START until the buffer is re-centered (approximately nine character periods).

To ensure compatibility between the source and destination systems when operating in BIST modes, the sending and receiving ends of the link must use the same receive clock configuration.

Device Configuration and Control Interface

The CYP(V)(W)15G0403DXB is highly configurable via the configuration interface. The configuration interface allows the device to be configured globally or allows each channel to be configured independently. Table 9 lists the configuration latches within the device including the initialization value of the latches upon the assertion of RESET. Table 10 on page 24 shows how the latches are mapped in the device. Each row in the Table 10 maps to a 8-bit latch bank. There are 16 such write-only latch banks. When WREN = 0, the logic value in the DATA[7:0] is latched to the latch bank specified by the values in ADDR[3:0]. The second column of Table 10 specifies the channels associated with the corresponding latch bank. For example, the first three latch banks (0,1 and 2) consist of configuration bits for channel A. The latch banks 12, 13 and 14 consist of Global configuration bits and the last latch bank (15) is the Mask latch bank that can be configured to perform bit-by-bit configuration.

Global Enable Function

The global enable function, controlled by the GLENx bits, is a feature that can be used to reduce the number of write operations needed to setup the latch banks. This function is beneficial in systems that use a common configuration in multiple channels. The GLENx bit is present in bit 0 of latch banks 0 through 11 only. Its default value (1) enables the global update of the latch bank's contents. Setting the GLENx bit to 0 disables this functionality.

Latch Banks 12, 13, and 14 are used to load values in the related latch banks in a global manner. A write operation to latch bank 12 could do a global write to latch banks 0, 3, 6, and 9 depending on the value of GLENx in these latch banks; latch bank 13 could do a global write to latch banks 1, 4, 7 and 10; and latch banks 14 could do a global write to latch banks 2, 5,

8 and 11. The GLENx bit cannot be modified by a global write operation.

Force Global Enable Function

FGLENx forces the global update of the target latch banks, but does not change the contents of the GLENx bits. If FGLENx = 1 for the associated global channel, FGLENx forces the global update of the target latch banks.

Mask Function

An additional latch bank (15) is used as a global mask vector to control the update of the configuration latch banks on a bit-by-bit basis. A logic 1 in a bit location allows for the update of that same location of the target latch bank(s), whereas a logic 0 disables it. The reset value of this latch bank is FFh, thereby making its use optional by default. The mask latch bank is not maskable. The FGLEN functionality is not affected by the bit 0 value of the mask latch bank.

Latch Types

There are two types of latch banks: static (S) and dynamic (D). Each channel is configured by 2 static and 1 dynamic latch banks. The S type contain those settings that normally do not change for a given application, whereas the D type controls the settings that could change dynamically during the application's lifetime. The first row of latches for each channel (address numbers 0, 3, 7, and 10) are the static receiver control latches. The second row of latches for each channel (address numbers 1, 4, 8, and 11) are the static transmitter control latches. The third row of latches for each channel (address numbers 2, 5, 9, and 12) are the dynamic control latches that are associated with enabling dynamic functions within the device.

Latch Bank 14 is also useful for those users that do not need the latch-based programmable feature of the device. This latch bank could be used in those applications that do not need to modify the default value of the static latch banks, and that can afford a global (i.e., not independent) control of the dynamic signals. In this case, this feature becomes available when ADDR[3:0] is left unchanged with a value of "1110" and WREN is left asserted. The signals present in DATA[7:0] effectively become global control pins, and for the latch banks 2, 5, 8 and 11.

Table 9. Device Configuration and Control Latch Descriptions

Name	Signal Description
RFMODEA[1:0] RFMODEB[1:0] RFMODEC[1:0] RFMODED[1:0]	Reframe Mode Select. The initialization value of the RFMODEx [1:0] latches = 10. RFMODEx is used to select the operating mode of the framer. When RFMODEx[1:0] = 00, the low-latency framer is selected. This frames on each occurrence of the selected framing character(s) in the received data stream. This mode of framing stretches the recovered clock for one or multiple cycles to align that clock with the recovered data. When RFMODEx[1:0] = 01, the alternate mode Multi-Byte parallel framer is selected. This requires detection of the selected framing character(s) in the received serial bit stream, on identical 10-bit boundaries, on four directly adjacent characters. The recovered character clock remains in the same phasing regardless of character offset. When RFMODEx[1:0] = 10, the Cypress-mode Multi-Byte parallel framer is selected. This requires a pair of the selected framing character(s), on identical 10-bit boundaries, within a span of 50 bits, before the character boundaries are adjusted. The recovered character clock remains in the same phasing regardless of character offset. RFMODEx[1:0] = 11 is reserved for test.

Table 9. Device Configuration and Control Latch Descriptions (continued)

Name	Signal Description
FRAMCHARA FRAMCHARB FRAMCHARC FRAMCHARD	Framing Character Select. The initialization value of the FRAMCHARx latch = 1. FRAMCHARx is used to select the character or portion of a character used for framing of each channel's received data stream. When FRAMCHARx = 1, the framer looks for either disparity of the K28.5 character. When FRAMCHARx = 0, the framer looks for either disparity of the 8-bit Comma characters. The specific bit combinations of these framing characters are listed in Table 6 on page 17 .
DECMODEA DECMODEB DECMODEC DECMODED	Receiver Decoder Mode Select. The initialization value of the DECMODEx latch = 1. DECMODEx selects the Decoder Mode used for the associated channel. When DECMODEx = 1 and decoder is enabled, the Cypress Decoding Mode is used. When DECMODEx = 0 and decoder is enabled, the Alternate Decoding mode is used. When the decoder is enabled (DECBYPx = 1), the 10-bit transmission characters are decoded using Table 15 on page 39 and Table 16 on page 43 . The column used in the Special Characters Table 16 is determined by the DECMODEx latch.
DECBYPA DECBYPB DECBYPC DECBYPD	Receiver Decoder Bypass. The initialization value of the DECByPx latch = 1. DECByPx selects if the Receiver Decoder is enabled or bypassed. When DECByPx = 1, the decoder is enabled and the Decoder Mode is selected by DECMODEx. When DECByPx = 0, the decoder is bypassed and raw 10-bit characters are passed through the receiver.
RXCKSELA RXCKSELB RXCKSELC RXCKSELD	Receive Clock Select. The initialization value of the RXCKSELx latch = 1. RXCKSELx selects the receive clock source used to transfer data to the Output Registers and the clock source for the RXCLK± output. When RXCKSELx = 1, the associated Output Registers, are clocked by REFCLKx± at the associated RXCLKx± output buffer. When RXCKSELx = 0, the associated Output Registers, are clocked by the Recovered Byte clock at the associated RXCLKx± output buffer. These output clocks may operate at the character-rate or half the character-rate as selected by RXRATEx.
RXRATEA RXRATEB RXRATEC RXRATED	Receive Clock Rate Select. The initialization value of the RXRATEx latch = 1. RXRATEx is used to select the rate of the RXCLKx± clock output. When RXRATEx = 1 and RXCKSELx = 0, the RXCLKx± clock outputs are complementary clocks that follow the recovered clock operating at half the character rate. Data for the associated receive channels should be latched alternately on the rising edge of RXCLKx+ and RXCLKx-. When RXRATEx = 0 and RXCKSELx = 0, the RXCLKx± clock outputs are complementary clocks that follow the recovered clock operating at the character rate. Data for the associated receive channels should be latched on the rising edge of RXCLKx+ or falling edge of RXCLKx-. When RXRATEx = 1 with RXCKSELx = 1 and REFCLKx± is a full-rate clock, the RXCLKx± clock outputs are complementary clocks that follow the reference clock operating at half the character rate. Data for the associated receive channels should be latched alternately on the rising edge of RXCLKx+ and RXCLKx-. When RXRATEx = 0 with RXCKSELx = 1 and REFCLKx± is a full-rate clock, the RXCLKx± clock outputs are complementary clocks that follow the reference clock operating at the character rate. Data for the associated receive channels should be latched on the rising edge of RXCLKx+ or falling edge of RXCLKx-. When RXCKSELx = 1 and REFCLKx± is a half-rate clock, the value of RXRATEx is not interpreted and the RXCLKx± clock outputs are complementary clocks that follow the reference clock operating at half the character rate. Data for the associated receive channels should be latched alternately on the rising edge of RXCLKx+ and RXCLKx-.
SDASEL1A[1:0] SDASEL1B[1:0] SDASEL1C[1:0] SDASEL1D[1:0]	Primary Serial Data Input Signal Detector Amplitude Select. The initialization value of the SDASEL1x[1:0] latch = 10. SDASEL1x[1:0] selects the trip point for the detection of a valid signal for the INx1± Primary Differential Serial Data Inputs. When SDASEL1x[1:0] = 00, the Analog Signal Detector is disabled. When SDASEL1x[1:0] = 01, the typical p-p differential voltage threshold level is 140 mV. When SDASEL1x[1:0] = 10, the typical p-p differential voltage threshold level is 280 mV. When SDASEL1x[1:0] = 11, the typical p-p differential voltage threshold level is 420 mV.
SDASEL2A[1:0] SDASEL2B[1:0] SDASEL2C[1:0] SDASEL2D[1:0]	Secondary Serial Data Input Signal Detector Amplitude Select. The initialization value of the SDASEL2x[1:0] latch = 10. SDASEL2x[1:0] selects the trip point for the detection of a valid signal for the INx2± Secondary Differential Serial Data Inputs. When SDASEL2x[1:0] = 00, the Analog Signal Detector is disabled When SDASEL2x[1:0] = 01, the typical p-p differential voltage threshold level is 140 mV. When SDASEL2x[1:0] = 10, the typical p-p differential voltage threshold level is 280 mV. When SDASEL2x[1:0] = 11, the typical p-p differential voltage threshold level is 420 mV.

Table 9. Device Configuration and Control Latch Descriptions (continued)

Name	Signal Description
ENCBYPA ENCBYPB ENCBYPC ENCBYPD	Transmit Encoder Bypassed. The initialization value of the ENCBYPx latch = 1. ENCBYPx selects if the Transmit Encoder is enabled or bypassed. When ENCBYPx = 1, the Transmit encoder is enabled. When ENCBYPx = 0, the Transmit Encoder is bypassed and raw 10-bit characters are transmitted.
TXCKSELA TXCKSELB TXCKSELC TXCKSELD	Transmit Clock Select. The initialization value of the TXCKSELx latch = 1. TXCKSELx selects the clock source used to write data into the Transmit Input Register. When TXCKSELx = 1, the associated input register, TXDx[7:0] and TXCTx[1:0], is clocked by REFCLKx↑. In this mode, the phase alignment buffer in the transmit path is bypassed. When TXCKSELx = 0, the associated TXCLKx↑ is used to clock in the input registers, TXDx[7:0] and TXCTx[1:0].
TXRATEA TXRATEB TXRATEC TXRATED	Transmit PLL Clock Rate Select. The initialization value of the TXRATEx latch = 0. TXRATEx is used to select the clock multiplier for the Transmit PLL. When TXRATEx = 0, each transmit PLL multiplies the associated REFCLKx± input by 10 to generate the serial bit-rate clock. When TXRATEx = 0, the TXCLKOx output clocks are full-rate clocks and follow the frequency and duty cycle of the associated REFCLKx± input. When TXRATEx = 1, each Transmit PLL multiplies the associated REFCLKx± input by 20 to generate the serial bit-rate clock. When TXRATEx = 1, the TXCLKOx output clocks are twice the frequency rate of the REFCLKx± input. When TXCKSELx = 1 and TXRATEx = 1, the Transmit Data Inputs are captured using both the rising and falling edges of REFCLKx. TXRATEx = 1 and SPDSELx is LOW, is an invalid state and this combination is reserved.
RFENA RFENB RFENC RFEND	Reframe Enable. The initialization value of the RFENx latch = 1. RFENx selects if the receiver framer is enabled or disabled. When RFENx = 1, the associated channel's framer is enabled to frame per the presently enabled framing mode and selected framing character. When RFENx = 0, the associated channel's framer is disabled, and no received bits alters the frame offset.
RXPLLPDA RXPLLPDB RXPLLPDC RXPLLPDD	Receive Channel Enable. The initialization value of the RXPLLPDx latch = 0. RXPLLPDx selects if the associated receive channel is enabled or powered-down. When RXPLLPDx = 0, the associated PLL and analog circuitry is powered-down. When RXPLLPDx = 1, the associated PLL and analog circuitry is enabled.
RXBISTA RXBISTB RXBISTC RXBISTD	Receive Bist Disabled. The initialization value of the RXBISTx latch = 1. RXBISTx selects if receive BIST is disabled or enabled. When RXBISTx = 1, the receiver BIST function is disabled. When RXBISTx = 0, the receive BIST function is enabled.
TXBISTA TXBISTB TXBISTC TXBISTD	Transmit Bist Disabled. The initialization value of the TXBISTx latch = 1. TXBISTx selects if the transmit BIST is disabled or enabled. When TXBISTx = 1, the transmit BIST function is disabled. When TXBISTx = 0, the transmit BIST function is enabled.
OE2A OE2B OE2C OE2D	Secondary Differential Serial Data Output Driver Enable. The initialization value of the OE2x latch = 0. OE2x selects if the OUT2± secondary differential output drivers are enabled or disabled. When OE2x = 1, the associated serial data output driver is enabled allowing data to be transmitted from the transmit shifter. When OE2x = 0, the associated serial data output driver is disabled. When a driver is disabled via the configuration interface, it is internally powered down to reduce device power. If both serial drivers for a channel are in this disabled state, the associated internal logic for that channel is also powered down. A device reset (RESET sampled LOW) disables all output drivers.
OE1A OE1B OE1C OE1D	Primary Differential Serial Data Output Driver Enable. The initialization value of the OE1x latch = 0. OE1x selects if the OUT1± primary differential output drivers are enabled or disabled. When OE1x = 1, the associated serial data output driver is enabled allowing data to be transmitted from the transmit shifter. When OE1x = 0, the associated serial data output driver is disabled. When a driver is disabled via the configuration interface, it is internally powered down to reduce device power. If both serial drivers for a channel are in this disabled state, the associated internal logic for that channel is also powered down. A device reset (RESET sampled LOW) disables all output drivers.
PABRSTA PABRSTB PABRSTC PABRSTD	Transmit Clock Phase Alignment Buffer Reset. The initialization value of the PABRSTx latch = 1. The PABRSTx is used to re-center the Transmit Phase Align Buffer. When the configuration latch PABRSTx is written as a 0, the phase of the TXCLKx input clock relative to its associated REFCLKx± is initialized. PABRST is an asynchronous input, but is sampled by each TXCLKx↑ to synchronize it to the internal clock domain. PABRSTx is a self clearing latch. This eliminates the requirement of writing a 1 to complete the initialization of the Phase Alignment Buffer.

Table 9. Device Configuration and Control Latch Descriptions (continued)

Name	Signal Description
GLEN[11..0]	Global Enable. The initialization value of the GLENx latch = 1. The GLENx is used to reconfigure several channels simultaneously in applications where several channels may have the same configuration. When GLENx = 1 for a given address, that address is allowed to participate in a global configuration. When GLENx = 0 for a given address, that address is disabled from participating in a global configuration.
FGLEN[2..0]	Force Global Enable. The initialization value of the FGLENx latch is NA. The FGLENx latch forces a Global Enable no matter what the setting is on the GLENx latch. If FGLENx = 1 for the associated Global channel, FGLEN forces the global update of the target latch banks.

Device Configuration Strategy

The following is a series of ordered events needed to load the configuration latches on a per channel basis:

1. Pulse $\overline{\text{RESET}}$ Low after device power-up. This operation resets all four channels. Initialize the JTAG state machine to its reset state as detailed in “JTAG Support” on page 24.
2. Set the static receiver latch bank for the target channel. May be performed using a global operation, if the application permits it. [Optional step if the default settings match the desired configuration.]
3. Set the static transmitter latch bank for the target channel. May be performed using a global operation, if the application permits it. [Optional step if the default settings match the desired configuration.]
4. Set the dynamic bank of latches for the target channel. Enable the Receive PLLs and transmit channels. May be performed using a global operation, if the application permits it. [Required step.]
5. Reset the Phase Alignment Buffer for the target channel. May be performed using a global operation, if the application permits it. [Optional if phase align buffer is bypassed.]

When a receive channel is configured with the decoder bypassed and the receive clock selected as recovered clock in half-rate mode (DECBYPx = 0, RXRATEx = 1, RXCKSELx = 0), the channel cannot be dynamically reconfigured to enable the decoder with RXCLKx selected as the REFCLKx (DECBYPx = 1, RXCKSELx = 1). If such a change is desired, a global reset should be performed and all channels should be reconfigured to the desired settings.

Table 10. Device Control Latch Configuration Table

ADDR	Channel	Type	DATA7	DATA6	DATA5	DATA4	DATA3	DATA2	DATA1	DATA0	Reset Value
0 (0000b)	A	S	RFMODEA[1]	RFMODEA[0]	FRAMCHARA	DECMODEA	DECBYPA	RXCKSELA	RXRATEA	GLEN0	10111111
1 (0001b)	A	S	SDASEL2A[1]	SDASEL2A[0]	SDASEL1A[1]	SDASEL1A[0]	ENCBYPA	TXCKSELA	TXRATEA	GLEN1	10101101
2 (0010b)	A	D	RFENA	RXPLLPDA	RXBISTA	TXBISTA	OE2A	OE1A	PABRSTA	GLEN2	10110011
3 (0011b)	B	S	RFMODEB[1]	RFMODEB[0]	FRAMCHARB	DECMODEB	DECBYPB	RXCKSELB	RXRATEB	GLEN3	10111111
4 (0100b)	B	S	SDASEL2B[1]	SDASEL2B[0]	SDASEL1B[1]	SDASEL1B[0]	ENCBYPB	TXCKSELB	TXRATEB	GLEN4	10101101
5 (0101b)	B	D	RFENB	RXPLLPDB	RXBISTB	TXBISTB	OE2B	OE1B	PABRSTB	GLEN5	10110011
6 (0110b)	C	S	RFMODEC[1]	RFMODEC[0]	FRAMCHARC	DECMODEC	DECBYPC	RXCKSELC	RXRATEC	GLEN6	10111111
7 (0111b)	C	S	SDASEL2C[1]	SDASEL2C[0]	SDASEL1C[1]	SDASEL1C[0]	ENCBYPC	TXCKSELC	TXRATEC	GLEN7	10101101
8 (1000b)	C	D	RFENC	RXPLLPDC	RXBISTC	TXBISTC	OE2C	OE1C	PABRSTC	GLEN8	10110011
9 (1001b)	D	S	RFMODED[1]	RFMODED[0]	FRAMCHARD	DECMODED	DECBYPD	RXCKSELD	RXRATE D	GLEN9	10111111
10 (1010b)	D	S	SDASEL2D[1]	SDASEL2D[0]	SDASEL1D[1]	SDASEL1D[0]	ENCBYPD	TXCKSELD	TXRATED	GLEN10	10101101
11 (1011b)	D	D	RFEND	RXPLLPDD	RXBISTD	TXBISTD	OE2D	OE1D	PABRSTD	GLEN11	10110011
12 (1100b)	GLOBAL	S	RFMODEGL[1]	RFMODEGL[0]	FRAMCHARGL	DECMODEGL	DECBYPGL	RXCKSELGL	RXRATEGL	FGLEN0	N/A
13 (1101b)	GLOBAL	S	SDASEL2GL[1]	SDASEL2GL[0]	SDASEL1GL[1]	SDASEL1GL[0]	ENCBPGL	TXCKSELGL	TXRATEGL	FGLEN1	N/A
14 (1110b)	GLOBAL	D	RFENGL	RXPLLPDGL	RXBISTGL	TXBISTGL	OE2GL	OE1GL	PABRSTGL	FGLEN2	N/A
15 (1111b)	MASK	D	D7	D6	D5	D4	D3	D2	D1	D0	11111111

JTAG Support

The CYP(V)(W)15G0403DXB contains a JTAG port to allow system level diagnosis of device interconnect. Of the available JTAG modes, boundary scan, and bypass are supported. This capability is present only on the LVTTL inputs and outputs and the REFCLKx± clock input. The high-speed serial inputs and outputs are not part of the JTAG test chain.

To ensure valid device operation after power-up (including non-JTAG operation), the JTAG state machine should also be initialized to a reset state. This should be done in addition to the device reset (using RESET). The JTAG state machine can be initialized using TRST (asserting it LOW and de-asserting it or leaving it asserted), or by asserting TMS HIGH for at least 5 consecutive TCLK cycles. This is necessary in order to

ensure that the JTAG controller does not enter any of the test modes after device power-up. In this JTAG reset state, the rest of the device will be in normal operation.

Note. The order of device reset (using RESET) and JTAG initialization does not matter.

3-Level Select Inputs

Each 3-Level select inputs reports as two bits in the scan register. These bits report the LOW, MID, and HIGH state of the associated input as 00, 10, and 11 respectively

JTAG ID

The JTAG device ID for the CYP(V)(W)15G0403DXB is '0C810069'x.

Table 11. Receive Character Status Bits

RXSTx[2:0]	Priority	Description	
		Normal Status	Receive BIST Status (Receive BIST = Enabled)
000	7	Normal character received. The valid Data character on the output bus meets all the formatting requirements of Data characters listed in Table 15 on page 39 .	BIST Data Compare. Character compared correctly.
001	7	Special code detected. The valid special character on the output bus meets all the formatting requirements of Special Code characters listed in Table 16 on page 43 , but is not the presently selected framing character or a decoder violation indication.	BIST Command Compare. Character compared correctly.
010	2	Receive Elasticity buffer underrun/overflow error. The receive buffer was not able to add/drop a K28.5 or framing character	BIST Last Good. Last Character of BIST sequence detected and valid.
011	5	Framing character detected. This indicates that a character matching the patterns identified as a framing character (as selected by FRAMCHARx) was detected. The decoded value of this character is present in the associated output bus.	
100	4	Codeword violation. The character on the output bus is a C0.7. This indicates that the received character cannot be decoded into any valid character.	BIST Last Bad. Last Character of BIST sequence detected invalid.
101	1	Loss of sync. This indicates a PLL Out of Lock condition	BIST Start. Receive BIST is enabled on this channel, but character compares have not yet commenced. This also indicates a PLL Out of Lock condition, and Elasticity Buffer overflow/underflow conditions.
110	6	Running disparity error. The character on the output bus is a C4.7, C1.7, or C2.7.	BIST Error. While comparing characters, a mismatch was found in one or more of the decoded character bits.
111	3	Reserved	BIST Wait. The receiver is comparing characters. but has not yet found the start of BIST character to enable the LFSR.

Figure 2. Receive BIST State Machine

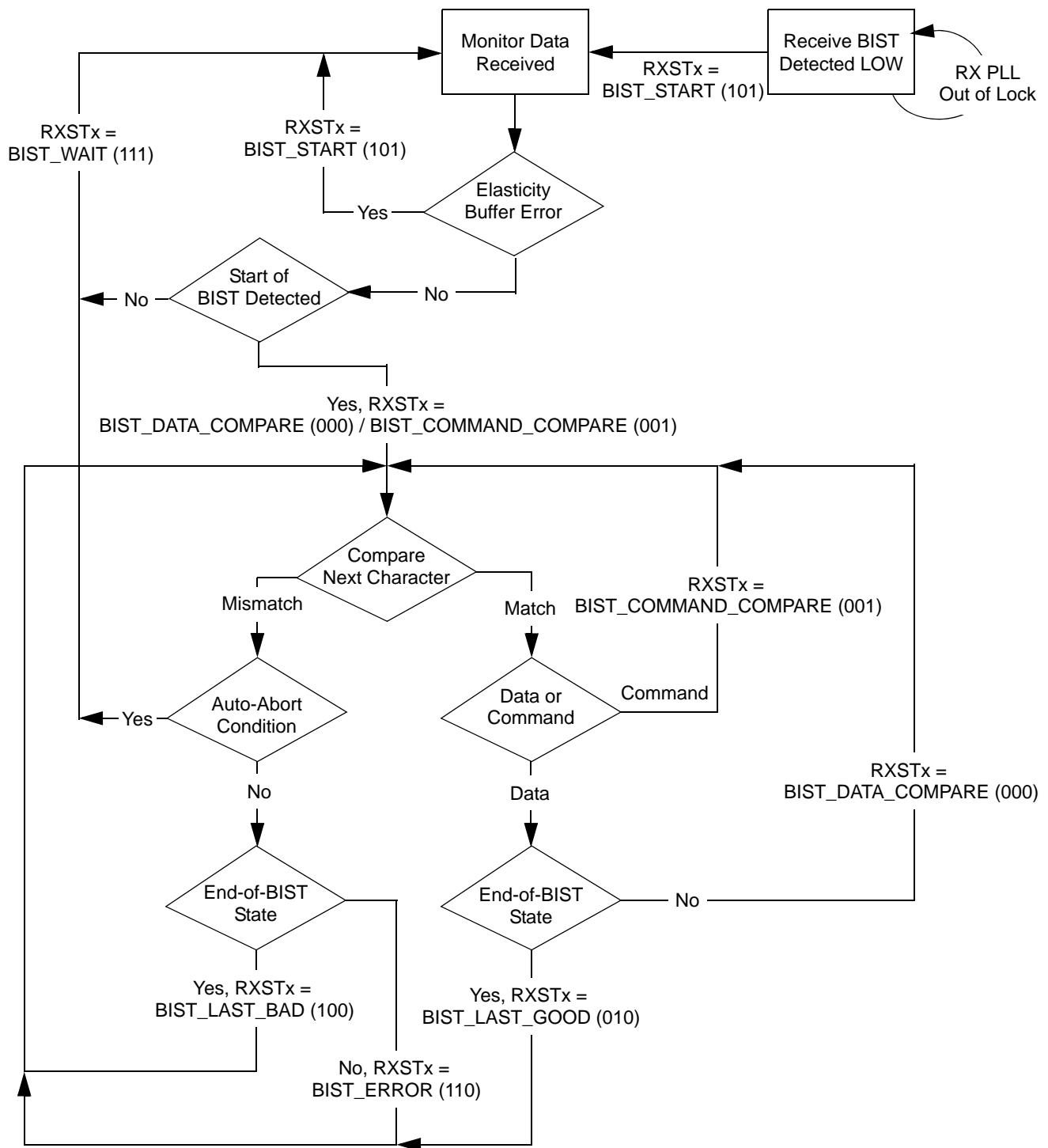



Maximum Ratings

Above which the useful life may be impaired. User guidelines only, not tested

Storage Temperature	-65°C to +150°C
Ambient Temperature with Power Applied.....	-55°C to +125°C
Supply Voltage to Ground Potential	-0.5V to +3.8V
DC Voltage Applied to LVTTL Outputs in High-Z State	-0.5V to $V_{CC} + 0.5V$
Output Current into LVTTL Outputs (LOW).....	60 mA
DC Input Voltage.....	-0.5V to $V_{CC} + 0.5V$

Static Discharge Voltage..... > 2000 V (per MIL-STD-883, Method 3015)

Latch-up Current..... > 200 mA

Power-up Requirements

The CYP(V)(W)15G0403DXB requires one power-supply. The Voltage on any input or I/O pin cannot exceed the power pin during power-up.

Operating Range

Range	Ambient Temperature	V_{CC}
Commercial	0°C to +70°C	+3.3V ±5%
Industrial	-40°C to +85°C	+3.3V ±5%

CYP(V)(W)15G0403DXB DC Electrical Characteristics

Parameter	Description	Test Conditions	Min.	Max.	Unit
LVTTL-compatible Outputs					
V_{OHT}	Output HIGH Voltage	$I_{OH} = -4 \text{ mA}$, $V_{CC} = \text{Min.}$	2.4		V
V_{OLT}	Output LOW Voltage	$I_{OL} = 4 \text{ mA}$, $V_{CC} = \text{Min.}$		0.4	V
I_{OST}	Output Short Circuit Current	$V_{OUT} = 0V^{[10]}$, $V_{CC} = 3.3V$	-20	-100	mA
I_{OZL}	High-Z Output Leakage Current	$V_{OUT} = 0V$, V_{CC}	-20	20	µA
LVTTL-compatible Inputs					
V_{IHT}	Input HIGH Voltage		2.0	$V_{CC} + 0.3$	V
V_{ILT}	Input LOW Voltage		-0.5	0.8	V
I_{IHT}	Input HIGH Current	REFCLKx Input, $V_{IN} = V_{CC}$		1.5	mA
		Other Inputs, $V_{IN} = V_{CC}$		+40	µA
I_{ILT}	Input LOW Current	REFCLKx Input, $V_{IN} = 0.0V$		-1.5	mA
		Other Inputs, $V_{IN} = 0.0V$		-40	µA
I_{IHPDT}	Input HIGH Current with internal pull-down	$V_{IN} = V_{CC}$		+200	µA
I_{ILPUT}	Input LOW Current with internal pull-up	$V_{IN} = 0.0V$		-200	µA
LVDIFF Inputs: REFCLKx±					
$V_{DIFF}^{[11]}$	Input Differential Voltage		400	V_{CC}	mV
V_{IHHP}	Highest Input HIGH Voltage		1.2	V_{CC}	V
V_{ILLP}	Lowest Input LOW voltage		0.0	$V_{CC}/2$	V
$V_{COMREF}^{[12]}$	Common Mode Range		1.0	$V_{CC} - 1.2V$	V
3-Level Inputs					
V_{IHH}	Three-Level Input HIGH Voltage	$\text{Min.} \leq V_{CC} \leq \text{Max.}$	$0.87 * V_{CC}$	V_{CC}	V
V_{IMM}	Three-Level Input MID Voltage	$\text{Min.} \leq V_{CC} \leq \text{Max.}$	$0.47 * V_{CC}$	$0.53 * V_{CC}$	V
V_{ILL}	Three-Level Input LOW Voltage	$\text{Min.} \leq V_{CC} \leq \text{Max.}$	0.0	$0.13 * V_{CC}$	V
I_{IHH}	Input HIGH Current	$V_{IN} = V_{CC}$		200	µA
I_{IMM}	Input MID current	$V_{IN} = V_{CC}/2$	-50	50	µA
I_{ILL}	Input LOW current	$V_{IN} = \text{GND}$		-200	µA

Notes

- Tested one output at a time, output shorted for less than one second, less than 10% duty cycle.
- This is the minimum difference in voltage between the true and complement inputs required to ensure detection of a logic-1 or logic-0. A logic-1 exists when the true (+) input is more positive than the complement (-) input. A logic-0 exists when the complement (-) input is more positive than true (+) input.
- The common mode range defines the allowable range of REFCLKx+ and REFCLKx- when REFCLKx+ = REFCLKx-. This marks the zero-crossing between the true and complement inputs as the signal switches between a logic-1 and a logic-0.

CYP(V)(W)15G0403DXB DC Electrical Characteristics (continued)

Parameter	Description	Test Conditions	Min.	Max.	Unit	
Differential CML Serial Outputs: OUTA1±, OUTA2±, OUTB1±, OUTB2±, OUTC1±, OUTC2±, OUTD1±, OUTD2±						
V _{OHC}	Output HIGH Voltage (V _{CC} Referenced)	100Ω differential load	V _{CC} - 0.5	V _{CC} - 0.2	V	
		150Ω differential load	V _{CC} - 0.5	V _{CC} - 0.2	V	
V _{OLC}	Output LOW Voltage (V _{CC} Referenced)	100Ω differential load	V _{CC} - 1.4	V _{CC} - 0.7	V	
		150Ω differential load	V _{CC} - 1.4	V _{CC} - 0.7	V	
V _{ODIF}	Output Differential Voltage (OUT+) - (OUT-)	100Ω differential load	450	900	mV	
		150Ω differential load	560	1000	mV	
Differential Serial Line Receiver Inputs: INA1±, INA2±, INB1±, INB2±, INC1±, INC2±, IND1±, IND2±						
V _{DIFFs} ^[11]	Input Differential Voltage (IN+) - (IN-)		100	1200	mV	
V _{IHE}	Highest Input HIGH Voltage			V _{CC}	V	
V _{ILE}	Lowest Input LOW Voltage		V _{CC} - 2.0		V	
I _{IHE}	Input HIGH Current	V _{IN} = V _{IHE} Max.		1350	μA	
I _{ILE}	Input LOW Current	V _{IN} = V _{ILE} Min.	-700		μA	
V _{COM} ^[13]	Common Mode input range	((V _{CC} - 2.0V)+0.5)min, (V _{CC} - 0.5V) max.	+1.25	+3.1	V	
Power Supply			Typ.	Max.		
I _{CC} ^[14, 15]	Max Power Supply Current	REFCLKx = MAX	Commercial	910	1270	mA
			Industrial			1320
I _{CC} ^[14, 15]	Typical Power Supply Current	REFCLKx = 125 MHz	Commercial	900	1270	mA
			Industrial			1320

AC Test Loads and Waveforms

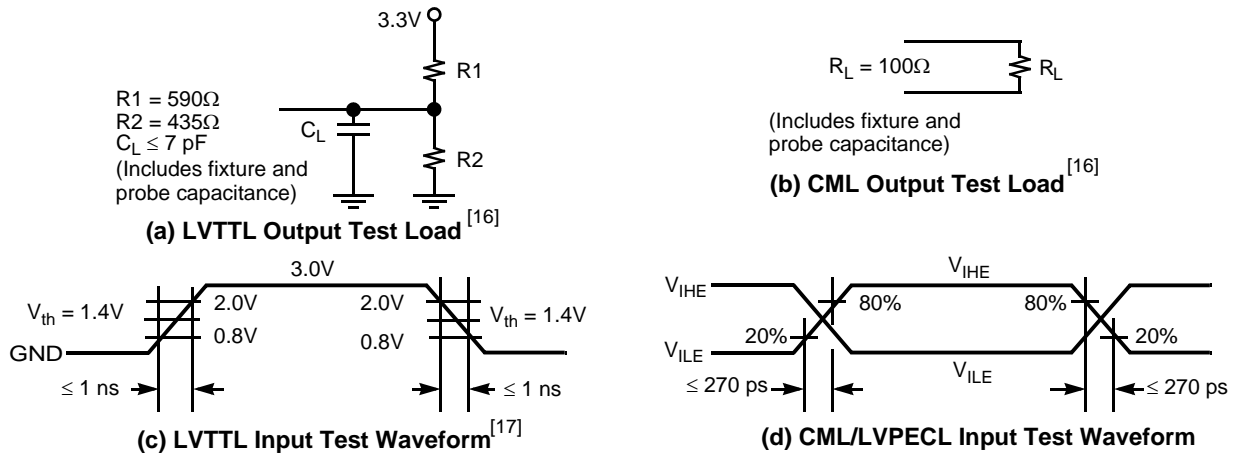

Notes

- The common mode range defines the allowable range of INPUT+ and INPUT- when INPUT+ = INPUT-. This marks the zero-crossing between the true and complement inputs as the signal switches between a logic-1 and a logic-0.
- Maximum I_{CC} is measured with V_{CC} = MAX, RFENx = 0, T_A = 25°C, with all channels and Serial Line Drivers enabled, sending a continuous alternating 01 pattern, and outputs unloaded.
- Typical I_{CC} is measured under similar conditions except with V_{CC} = 3.3V, T_A = 25°C, RFENx = 0, with all channels enabled and one Serial Line Driver per transmit channel sending a continuous alternating 01 pattern. The redundant outputs on each channel are powered down and the parallel outputs are unloaded.
- Cypress uses constant current (ATE) load configurations and forcing functions. This figure is for reference only.
- The LVTTTL switching threshold is 1.4V. All timing references are made relative to where the signal edges cross the threshold voltage.

CYP(V)(W)15G0403DXB AC Electrical Characteristics

Parameter	Description	Min.	Max	Unit
CYP(V)(W)15G0403DXB Transmitter LVTTTL Switching Characteristics Over the Operating Range				
f_{TS}	TXCLKx Clock Cycle Frequency	19.5	150 ^[18]	MHz
t_{TXCLK}	TXCLKx Period=1/ f_{TS}	6.66 ^[19]	51.28	ns
t_{TXCLKH} ^[20]	TXCLKx HIGH Time	2.2		ns
t_{TXCLKL} ^[20]	TXCLKx LOW Time	2.2		ns
t_{TXCLKR} ^[20, 21, 22, 23]	TXCLKx Rise Time	0.2	1.7	ns
t_{TXCLKF} ^[20, 21, 22, 23]	TXCLKx Fall Time	0.2	1.7	ns
t_{TXDS}	Transmit Data Set-up Time to TXCLKx \uparrow (TXCKSELx \neq 0)	2.2		ns
t_{TXDH}	Transmit Data Hold Time from TXCLKx \uparrow (TXCKSELx \neq 0)	1.0		ns
f_{TOS}	TXCLKOx Clock Frequency = 1x or 2x REFCLKx Frequency	19.5	150 ^[18]	MHz
t_{TXCLKO}	TXCLKOx Period=1/ f_{TOS}	6.66 ^[19]	51.28	ns
$t_{TXCLKOD}$	TXCLKO Duty Cycle centered at 60% HIGH time	-1.9	0	ns
CYP(V)(W)15G0403DXB Receiver LVTTTL Switching Characteristics Over the Operating Range				
f_{RS}	RXCLKx \pm Clock Output Frequency	9.75	150 ^[18]	MHz
t_{RXCLKP}	RXCLKx \pm Period = 1/ f_{RS}	6.66 ^[19]	102.56	ns
t_{RXCLKD}	RXCLKx \pm Duty Cycle Centered at 50% (Full Rate and Half Rate when RXCKSELx = 0)	-1.0	+1.0	ns
t_{RXCLKR} ^[20]	RXCLKx \pm Rise Time	0.3	1.2	ns
t_{RXCLKF} ^[20]	RXCLKx \pm Fall Time	0.3	1.2	ns
t_{RXDV-} ^[24]	Status and Data Valid Time to RXCLKx \pm (RXRATEx = 0, RXCKSELx = 0) (Full Rate)	5UI - 2.0 ^[25]		ns
	Status and Data Valid Time to RXCLKx \pm (RXRATEx = 1, RXCKSELx = 0) (Half Rate)	5UI - 1.3 ^[25]		ns
t_{RXDV+} ^[24]	Status and Data Valid Time to RXCLKx \pm (RXRATEx = 0, RXCKSELx = 0) (Full Rate)	5UI-1.8 ^[25]		ns
	Status and Data Valid Time to RXCLKx \pm (RXRATEx = 1, RXCKSELx = 0) (Half Rate)	5UI - 2.6 ^[25]		ns
CYP(V)(W)15G0403DXB REFCLKx Switching Characteristics Over the Operating Range				
f_{REF}	REFCLKx Clock Frequency	19.5	150 ^[18]	MHz
t_{REFCLK}	REFCLKx Period = 1/ f_{REF}	6.66 ^[19]	51.28	ns
t_{REFH}	REFCLKx HIGH Time (TXRATEx = 1)(Half Rate)	5.9 ^[26]		ns
	REFCLKx HIGH Time (TXRATEx = 0)(Full Rate)	2.9 ^[20]		ns
t_{REFL}	REFCLKx LOW Time (TXRATEx = 1)(Half Rate)	5.9 ^[26]		ns
	REFCLKx LOW Time (TXRATEx = 0)(Full Rate)	2.9 ^[20]		ns
t_{REFD} ^[27]	REFCLKx Duty Cycle	30	70	%
t_{REFR} ^[20, 21, 22, 23]	REFCLKx Rise Time (20%–80%)		2	ns

Notes

18. This parameter is 154 MHz for CYW15G0403DXB.
19. This parameter is 6.49 ns for CYW15G0403DXB.
20. Tested initially and after any design or process changes that may affect these parameters, but not 100% tested.
21. The ratio of rise time to falling time must not vary by greater than 2:1.
22. For a given operating frequency, neither rise or fall specification can be greater than 20% of the clock-cycle period or the data sheet maximum time.
23. All transmit AC timing parameters measured with 1 ns typical rise time and fall time.
24. Parallel data output specifications are only valid if all outputs are loaded with similar DC and AC loads.
25. Receiver UI (Unit Interval) is calculated as 1/($f_{REF} * 20$) (when TXRATEx = 1) or 1/($f_{REF} * 10$) (when TXRATEx = 0). In an operating link this is equivalent to t_B .
26. If REFCLKx is selected as receive interface clock (RXCKSELx=1), then this parameter has to be greater than or equal to 6.3 ns.
27. The duty cycle specification is a simultaneous condition with the t_{REFH} and t_{REFL} parameters. This means that at faster character rates the REFCLKx \pm duty cycle cannot be as large as 30%–70%.

CYP(V)(W)15G0403DXB AC Electrical Characteristics (continued)

Parameter	Description	Min.	Max	Unit	
$t_{REFF}^{[20, 21, 22, 23]}$	REFCLKx Fall Time (20%–80%)		2	ns	
t_{TREFDS}	Transmit Data Set-up Time to REFCLKx - Full Rate (TXRATEx = 0, TXCKSELx = 1)	2.4		ns	
	Transmit Data Set-up Time to REFCLKx - Half Rate (TXRATEx = 1, TXCKSELx = 1)	2.3		ns	
t_{TREFDH}	Transmit Data Hold Time from REFCLKx - Full Rate (TXRATEx = 0, TXCKSELx = 1)	1.0		ns	
	Transmit Data Hold Time from REFCLKx - Half Rate (TXRATEx = 1, TXCKSELx = 1)	1.6		ns	
t_{RREFDA}	Receive Data Access Time to REFCLKx (RXCKSELx = 1)		9.7 ^[28]	ns	
t_{RREFDW}	Receive Data Valid Time Window (RXCKSELx = 1)	10UI – 5.8		ns	
$t_{REFxDV-}$	Received Data Valid Time to RXCLK when RXCKSELx = 1 (TXRATEx = 0, RXRATEx = 0)	10UI ^[25] – 6.16		ns	
	Received Data Valid Time to RXCLK when RXCKSELx = 1 (TXRATEx = 0, RXRATEx = 1)	5UI – 2.53 ^[29]		ns	
	Received Data Valid Time to RXCLK when RXCKSELx = 1 (TXRATEx = 1)	10UI – 5.86 ^[29]		ns	
$t_{REFxDV+}$	Received Data Valid Time from RXCLK when RXCKSELx = 1 (TXRATEx = 0, RXRATEx = 0)	1.4		ns	
	Received Data Valid Time from RXCLK when RXCKSELx = 1 (TXRATEx = 0, RXRATEx = 1)	5UI – 1.83 ^[29]		ns	
	Received Data Valid Time from RXCLK when RXCKSELx = 1 (TXRATEx = 1)	1.0 ^[29]		ns	
$t_{REFRX}^{[30]}$	REFCLKx Frequency Referenced to Received Clock Period	–0.15	+0.15	%	
CYP(V)(W)15G0403DXB Bus Configuration Write Timing Characteristics Over the Operating Range					
t_{DATAH}	Bus Configuration Data Hold	0		ns	
t_{DATAS}	Bus Configuration Data Set-up	10		ns	
t_{WRENP}	Bus Configuration WREN Pulse Width	10		ns	
CYP(V)(W)15G0403DXB JTAG Test Clock Characteristics Over the Operating Range					
f_{TCLK}	JTAG Test Clock Frequency		20	MHz	
t_{TCLK}	JTAG Test Clock Period	50		ns	
CYP(V)(W)15G0403DXB Device RESET Characteristics Over the Operating Range					
t_{RST}	Device RESET Pulse Width	30		ns	
CYP(V)(W)15G0403DXB Transmit Serial Outputs and TX PLL Characteristics Over the Operating Range					
Parameter	Description	Condition	Min.	Max.	Unit
t_B	Bit Time		5128	666	ps

Notes

28. Since this timing parameter is greater than the minimum time period of REFCLK it sets an upper limit to the frequency in which REFCLKx can be used to clock the receive data out of the output register. For predictable timing, users can use this parameter only if REFCLK period is greater than sum of t_{RREFDA} and set-up time of the upstream device. When this condition is not true, RXCLKx± (a buffered or divided version of REFCLK when RXCKSELx = 1) could be used to clock the receive data out of the device.

29. Measured using a 50% duty cycle reference clock.

30. REFCLKx has no phase or frequency relationship with the recovered clock and only acts as a centering reference to reduce clock synchronization time. REFCLKx must be within ±1500 ppm (±0.15%) of the remote transmitter's PLL reference (REFCLKx) frequency. Although transmitting to a HOTLink II receiver channel necessitates the frequency difference between the transmitter and receiver reference clocks to be within ±1500 ppm, the stability of the crystal needs to be within the limits specified by the appropriate standard when transmitting to a remote receiver that is compliant to that standard. For example, to be IEEE 802.3z Gigabit Ethernet compliant, the frequency stability of the crystal needs to be within ±100 ppm.

CYP(V)(W)15G0403DXB AC Electrical Characteristics (continued)

Parameter	Description		Min.	Max	Unit
t _{RISE} ^[20]	CML Output Rise Time 20–80% (CML Test Load)	SPDSELx = HIGH	60	270	ps
		SPDSELx = MID	100	500	ps
		SPDSELx =LOW	180	1000	ps
t _{FALL} ^[20]	CML Output Fall Time 80–20% (CML Test Load)	SPDSELx = HIGH	60	270	ps
		SPDSELx = MID	100	500	ps
		SPDSELx =LOW	180	1000	ps
t _{DJ} ^[20, 31, 33]	Deterministic Jitter (peak-peak) ^[34]	IEEE 802.3z		27	ps
t _{RJ} ^[20, 32, 33]	Random Jitter (σ) ^[34]	IEEE 802.3z		11	ps
t _{REFJ} ^[20]	REFCLKx jitter tolerance / Phase noise limits			TBD	
t _{TXLOCK}	Transmit PLLx lock to REFCLKx±			200	μs

CYP(V)(W)15G0403DXB Receive Serial Inputs and CDR PLL Characteristics Over the Operating Range

t _{RXLOCK}	Receive PLL lock to input data stream (cold start)			376k	UI
	Receive PLL lock to input data stream			376k	UI
t _{RXUNLOCK}	Receive PLL Unlock Rate			46	UI
t _{JTOL} ^[20]	Total Jitter Tolerance ^[34]	IEEE 802.3z	600		ps
t _{DJTOL} ^[20]	Deterministic Jitter Tolerance ^[34]	IEEE 802.3z	370		ps

Capacitance^[20]

Parameter	Description	Test Conditions	Max.	Unit
C _{INTTL}	TTL Input Capacitance	T _A = 25°C, f ₀ = 1 MHz, V _{CC} = 3.3V	7	pF
C _{INPECL}	PECL input Capacitance	T _A = 25°C, f ₀ = 1 MHz, V _{CC} = 3.3V	4	pF

Notes

31. While sending continuous K28.5s, outputs loaded to a balanced 100Ω load, measured at the cross point of differential outputs, over the operating range.

32. While sending continuous K28.7s, after 100,000 samples measured at the cross point of differential outputs, time referenced to REFCLKx± input, over the operating range.

33. Total jitter is calculated at an assumed BER of 1E-12. Hence: Total Jitter (t_J) = (t_{RJ} * 14) + t_{DJ}.

34. Also meets all Jitter Generation and Jitter Tolerance requirements as specified by SMPTE 259M, SMPTE 292M, ESCON, FICON, Fibre Channel, and DVB-ASI.

CYP(V)(W)15G0403DXB HOTLink II Transmitter Switching Waveforms

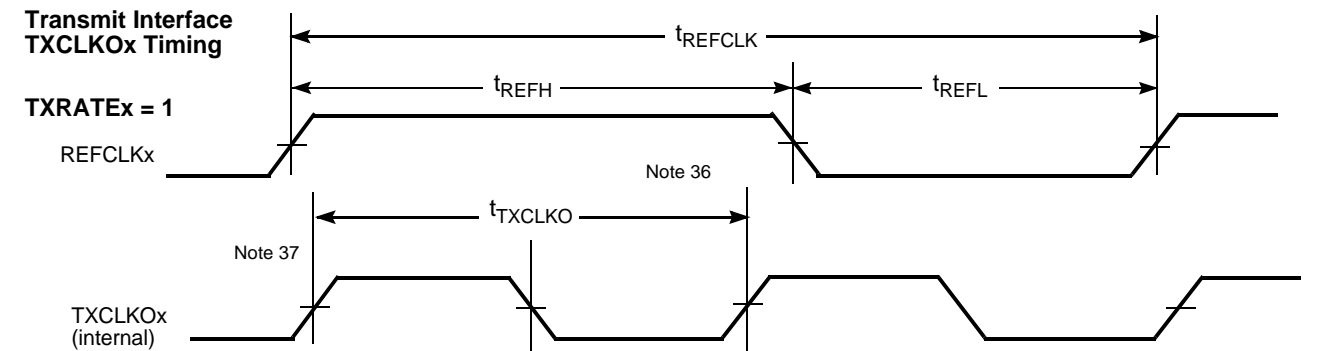
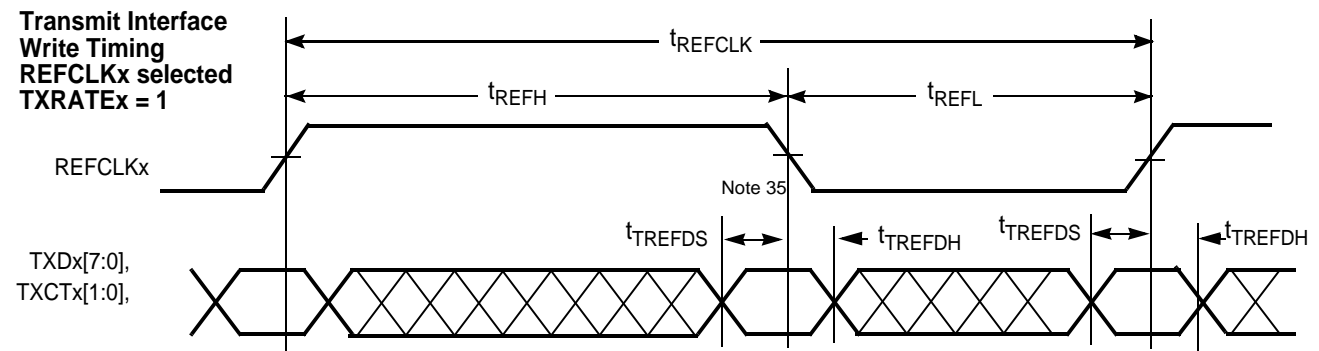
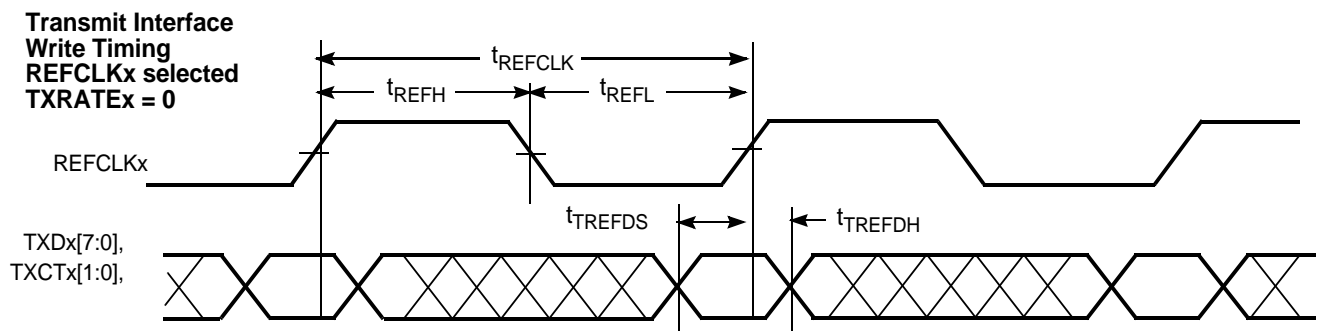
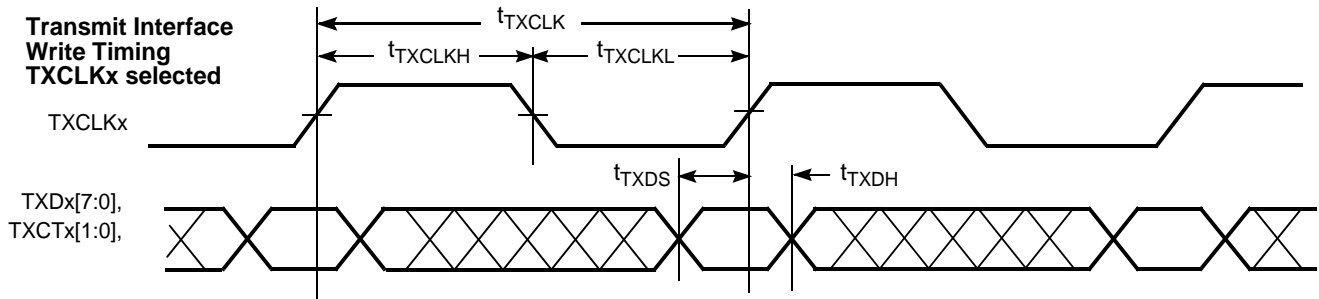

Notes

- 35. When REFCLKx± is configured for half-rate operation (TXRATE = 1) and data is captured using REFCLKx instead of a TXCLKx clock. Data is captured using both the rising and falling edges of REFCLKx.
- 36. The TXCLKOx output remains at the character rate regardless of the state of TXRATE and does not follow the duty cycle of REFCLKx±.
- 37. The rising edge of TXCLKOx output has no direct phase relationship to the REFCLKx± input.

CYP(V)(W)15G0403DXB HOTLink II Transmitter Switching Waveforms (continued)

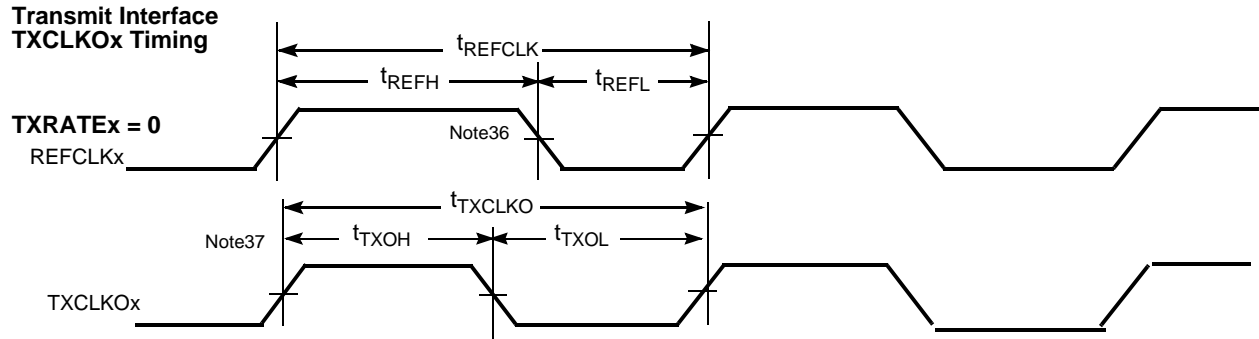

Switching Waveforms for the CYP(V)(W)15G0403DXB HOTLink II Receiver

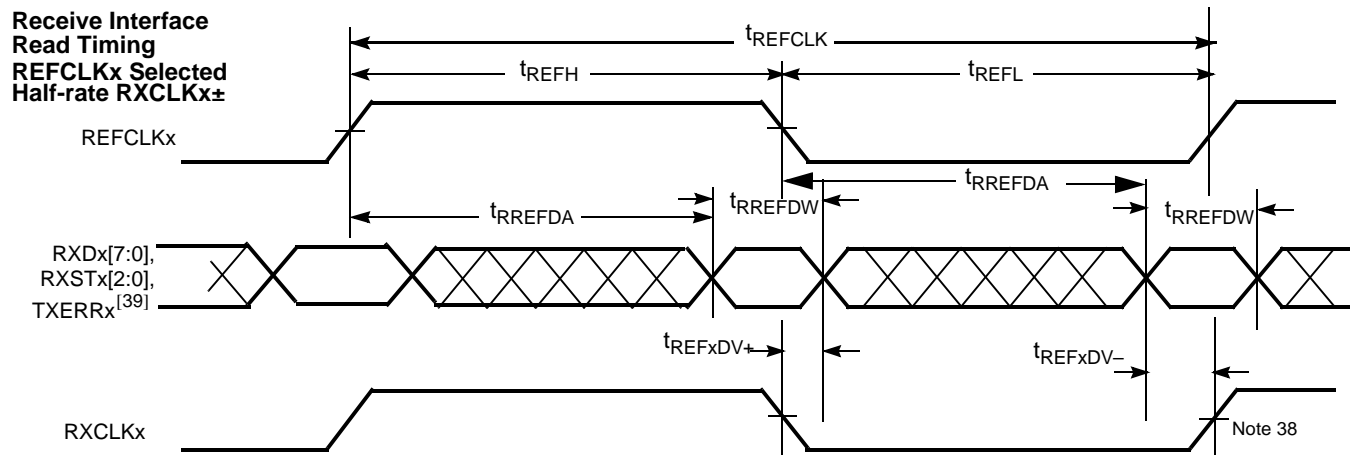
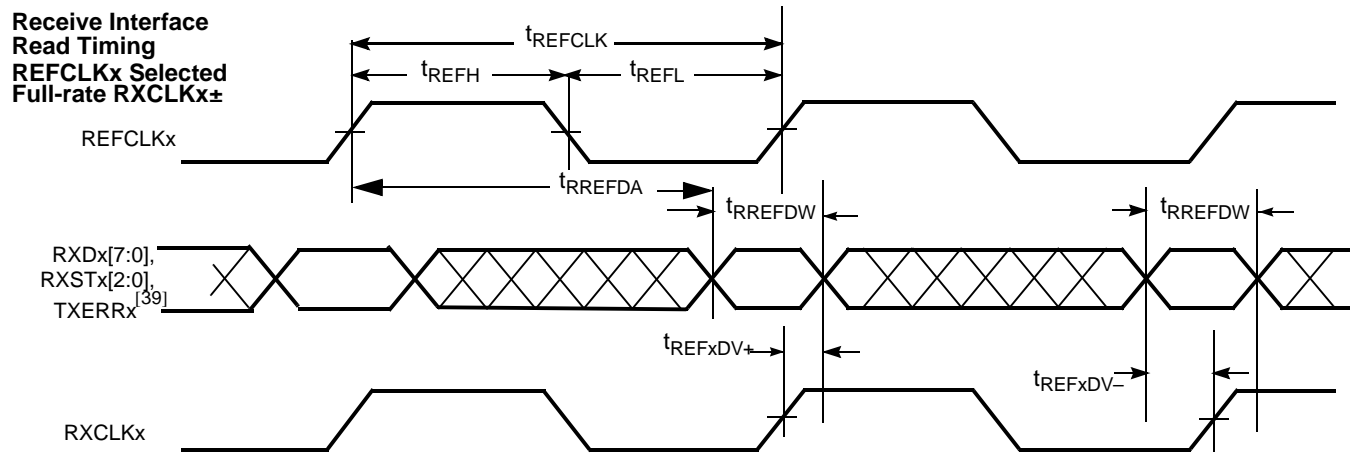

Notes

38. When operated with a half-rate REFCLKx±, the set-up and hold specifications for data relative to RXCLKx are relative to both rising and falling edges of the respective clock output
39. TXERRx is synchronous to RXCLKx only when RXCLKx is selected as REFCLK.

Switching Waveforms for the CYP(V)(W)15G0403DXB HOTLink II Receiver

Receive Interface
Read Timing
Recovered Clock selected
RXRATE_x = 0

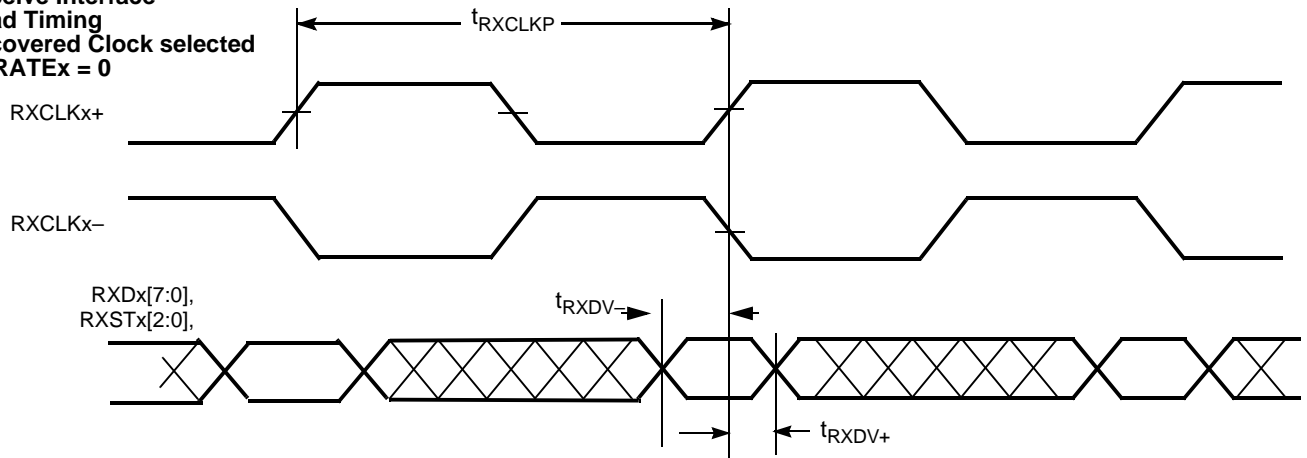

Receive Interface
Read Timing
Recovered Clock selected
RXRATE_x = 1

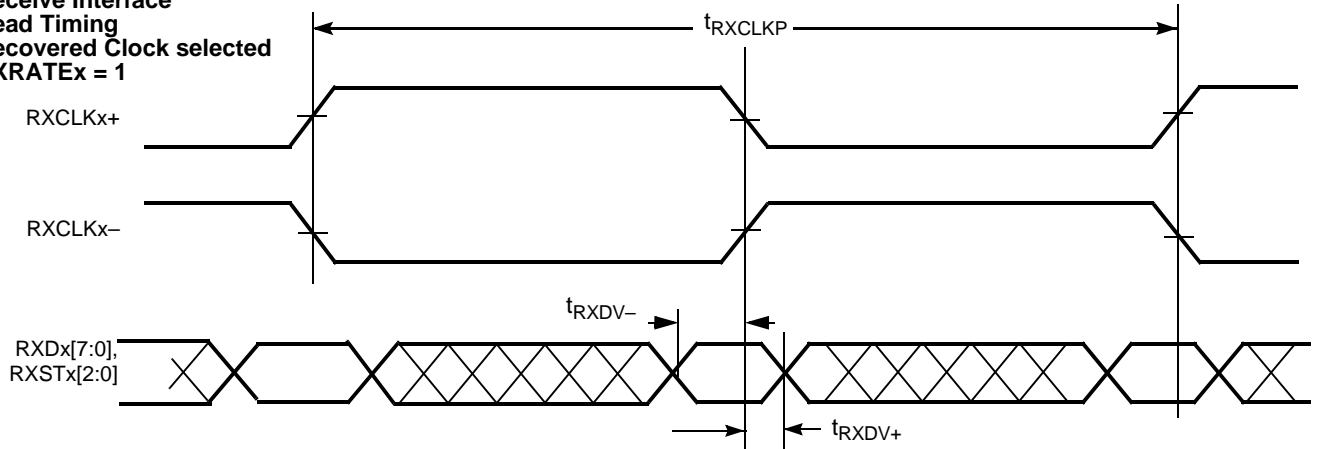

Bus Configuration
Write Timing

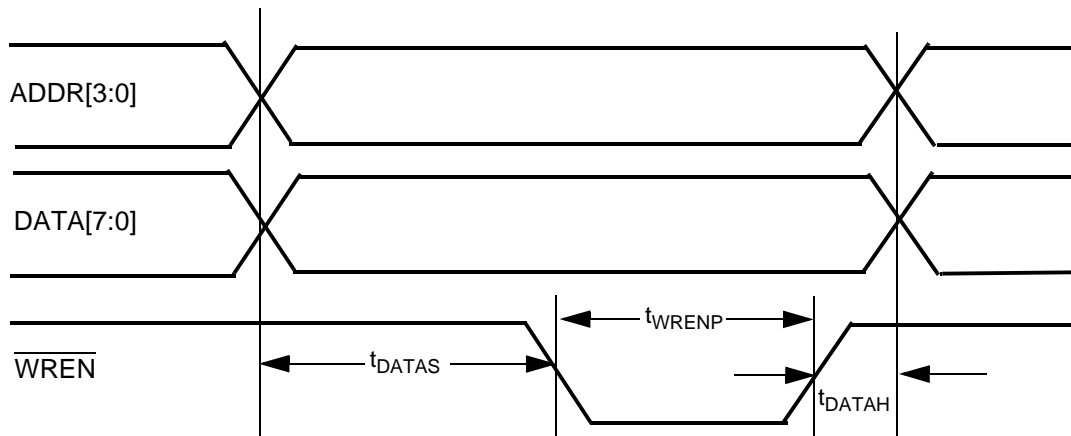

Table 12.Package Coordinate Signal Allocation

Ball ID	Signal Name	Signal Type	Ball ID	Signal Name	Signal Type	Ball ID	Signal Name	Signal Type
A01	INC1-	CML IN	C07	ULCC	LVTTTL IN PU	F17	NC	NO CONNECT
A02	OUTC1-	CML OUT	C08	GND	GROUND	F18	RXSTB[1]	LVTTTL OUT
A03	INC2-	CML IN	C09	DATA[7]	LVTTTL IN PU	F19	TXCLKOB	LVTTTL OUT
A04	OUTC2-	CML OUT	C10	DATA[5]	LVTTTL IN PU	F20	RXSTB[0]	LVTTTL OUT
A05	VCC	POWER	C11	DATA[3]	LVTTTL IN PU	G01	TXDC[7]	LVTTTL IN
A06	IND1-	CML IN	C12	DATA[1]	LVTTTL IN PU	G02	WREN	LVTTTL IN PU
A07	OUTD1-	CML OUT	C13	GND	GROUND	G03	TXDC[4]	LVTTTL IN
A08	GND	GROUND	C14	NC	NO CONNECT	G04	TXDC[1]	LVTTTL IN
A09	IND2-	CML IN	C15	SPDSELD	3-LEVEL SEL	G17	SPDSELB	3-LEVEL SEL
A10	OUTD2-	CML OUT	C16	VCC	POWER	G18	LPENC	LVTTTL IN PD
A11	INA1-	CML IN	C17	LDTDEN	LVTTTL IN PU	G19	SPDSELA	3-LEVEL SEL
A12	OUTA1-	CML OUT	C18	TRST	LVTTTL IN PU	G20	RXDB[1]	LVTTTL OUT
A13	GND	GROUND	C19	LPEND	LVTTTL IN PD	H01	GND	GROUND
A14	INA2-	CML IN	C20	TDO	LVTTTL 3-S OUT	H02	GND	GROUND
A15	OUTA2-	CML OUT	D01	TCLK	LVTTTL IN PD	H03	GND	GROUND
A16	VCC	POWER	D02	RESET	LVTTTL IN PU	H04	GND	GROUND
A17	INB1-	CML IN	D03	INSELD	LVTTTL IN	H17	GND	GROUND
A18	OUTB1-	CML OUT	D04	INSELA	LVTTTL IN	H18	GND	GROUND
A19	INB2-	CML IN	D05	VCC	POWER	H19	GND	GROUND
A20	OUTB2-	CML OUT	D06	ULCA	LVTTTL IN PU	H20	GND	GROUND
B01	INC1+	CML IN	D07	SPDSELC	3-LEVEL SEL	J01	TXCTC[1]	LVTTTL IN
B02	OUTC1+	CML OUT	D08	GND	GROUND	J02	TXDC[5]	LVTTTL IN
B03	INC2+	CML IN	D09	DATA[6]	LVTTTL IN PU	J03	TXDC[2]	LVTTTL IN
B04	OUTC2+	CML OUT	D10	DATA[4]	LVTTTL IN PU	J04	TXDC[3]	LVTTTL IN
B05	VCC	POWER	D11	DATA[2]	LVTTTL IN PU	J17	RXSTB[2]	LVTTTL OUT
B06	IND1+	CML IN	D12	DATA[0]	LVTTTL IN PU	J18	RXDB[0]	LVTTTL OUT
B07	OUTD1+	CML OUT	D13	GND	GROUND	J19	RXDB[5]	LVTTTL OUT
B08	GND	GROUND	D14	LPENB	LVTTTL IN PD	J20	RXDB[2]	LVTTTL OUT
B09	IND2+	CML IN	D15	ULCB	LVTTTL IN PU	K01	RXDC[2]	LVTTTL OUT
B10	OUTD2+	CML OUT	D16	VCC	POWER	K02	REFCLKC-	PECL IN
B11	INA1+	CML IN	D17	LPENA	LVTTTL IN PD	K03	TXCTC[0]	LVTTTL IN
B12	OUTA1+	CML OUT	D18	LTEN1	LVTTTL IN PD	K04	TXCLKC	LVTTTL IN PD
B13	GND	GROUND	D19	SCANEN2	LVTTTL IN PD	K17	RXDB[3]	LVTTTL OUT
B14	INA2+	CML IN	D20	TMEN3	LVTTTL IN PD	K18	RXDB[4]	LVTTTL OUT
B15	OUTA2+	CML OUT	E01	VCC	POWER	K19	RXDB[7]	LVTTTL OUT
B16	VCC	POWER	E02	VCC	POWER	K20	LFIB	LVTTTL OUT
B17	INB1+	CML IN	E03	VCC	POWER	L01	RXDC[3]	LVTTTL OUT
B18	OUTB1+	CML OUT	E04	VCC	POWER	L02	REFCLKC+	PECL IN
B19	INB2+	CML IN	E17	VCC	POWER	L03	LFIC	LVTTTL OUT
B20	OUTB2+	CML OUT	E18	VCC	POWER	L04	TXDC[6]	LVTTTL IN
C01	TDI	LVTTTL IN PU	E19	VCC	POWER	L17	RXDB[6]	LVTTTL OUT
C02	TMS	LVTTTL IN PU	E20	VCC	POWER	L18	RXCLKB+	LVTTTL OUT
C03	INSELC	LVTTTL IN	F01	RXDC[6]	LVTTTL OUT	L19	RXCLKB-	LVTTTL OUT

Table 12. Package Coordinate Signal Allocation (continued)

Ball ID	Signal Name	Signal Type	Ball ID	Signal Name	Signal Type	Ball ID	Signal Name	Signal Type
C04	INSELB	LVTTTL IN	F02	RXDC[7]	LVTTTL OUT	L20	TXDB[6]	LVTTTL IN
C05	VCC	POWER	F03	TXDC[0]	LVTTTL IN	M01	RXDC[4]	LVTTTL OUT
C06	ULCD	LVTTTL IN PU	F04	NC	NO CONNECT	M02	RXDC[5]	LVTTTL OUT
M03	NC	NO CONNECT	U03	TXDD[2]	LVTTTL IN	W03	LFID	LVTTTL OUT
M04	TXERRC	LVTTTL OUT	U04	TXCTD[1]	LVTTTL IN	W04	RXCLKD-	LVTTTL OUT
M17	REFCLKB+	PECL IN	U05	VCC	POWER	W05	VCC	POWER
M18	REFCLKB-	PECL IN	U06	RXDD[2]	LVTTTL OUT	W06	RXDD[4]	LVTTTL OUT
M19	TXERRB	LVTTTL OUT	U07	RXDD[1]	LVTTTL OUT	W07	RXSTD[1]	LVTTTL OUT
M20	TXCLKB	LVTTTL IN PD	U08	GND	GROUND	W08	GND	GROUND
N01	GND	GROUND	U09	TXCTA[1]	LVTTTL IN	W09	ADDR [3]	LVTTTL IN PU
N02	GND	GROUND	U10	ADDR [0]	LVTTTL IN PU	W10	ADDR [1]	LVTTTL IN PU
N03	GND	GROUND	U11	REFCLKD-	PECL IN	W11	RXCLKA+	LVTTTL OUT
N04	GND	GROUND	U12	TXDA[1]	LVTTTL IN	W12	TXERRA	LVTTTL OUT
N17	GND	GROUND	U13	GND	GROUND	W13	GND	GROUND
N18	GND	GROUND	U14	TXDA[4]	LVTTTL IN	W14	TXDA[2]	LVTTTL IN
N19	GND	GROUND	U15	TXCTA[0]	LVTTTL IN	W15	TXDA[6]	LVTTTL IN
N20	GND	GROUND	U16	VCC	POWER	W16	VCC	POWER
P01	RXDC[1]	LVTTTL OUT	U17	RXDA[2]	LVTTTL OUT	W17	LFIA	LVTTTL OUT
P02	RXDC[0]	LVTTTL OUT	U18	TXCTB[0]	LVTTTL IN	W18	REFCLKA+	PECL IN
P03	RXSTC[0]	LVTTTL OUT	U19	RXSTA[2]	LVTTTL OUT	W19	RXDA[4]	LVTTTL OUT
P04	RXSTC[1]	LVTTTL OUT	U20	RXSTA[1]	LVTTTL OUT	W20	RXDA[1]	LVTTTL OUT
P17	TXDB[5]	LVTTTL IN	V01	TXDD[3]	LVTTTL IN	Y01	TXDD[6]	LVTTTL IN
P18	TXDB[4]	LVTTTL IN	V02	TXDD[4]	LVTTTL IN	Y02	TXCLKD	LVTTTL IN PD
P19	TXDB[3]	LVTTTL IN	V03	TXCTD[0]	LVTTTL IN	Y03	RXDD[7]	LVTTTL OUT
P20	TXDB[2]	LVTTTL IN	V04	RXDD[6]	LVTTTL OUT	Y04	RXCLKD+	LVTTTL OUT
R01	RXSTC[2]	LVTTTL OUT	V05	VCC	POWER	Y05	VCC	POWER
R02	TXCLKOC	LVTTTL OUT	V06	RXDD[3]	LVTTTL OUT	Y06	RXDD[5]	LVTTTL OUT
R03	RXCLKC+	LVTTTL OUT	V07	RXSTD[0]	LVTTTL OUT	Y07	RXDD[0]	LVTTTL OUT
R04	RXCLKC-	LVTTTL OUT	V08	GND	GROUND	Y08	GND	GROUND
R17	TXDB[1]	LVTTTL IN	V09	RXSTD[2]	LVTTTL OUT	Y09	TXCLKOD	LVTTTL OUT
R18	TXDB[0]	LVTTTL IN	V10	ADDR [2]	LVTTTL IN PU	Y10	NC	NO CONNECT
R19	TXCTB[1]	LVTTTL IN	V11	REFCLKD+	PECL IN	Y11	TXCLKA	LVTTTL IN PD
R20	TXDB[7]	LVTTTL IN	V12	TXCLKOA	LVTTTL OUT	Y12	RXCLKA-	LVTTTL OUT
T01	VCC	POWER	V13	GND	GROUND	Y13	GND	GROUND
T02	VCC	POWER	V14	TXDA[3]	LVTTTL IN	Y14	TXDA[0]	LVTTTL IN
T03	VCC	POWER	V15	TXDA[7]	LVTTTL IN	Y15	TXDA[5]	LVTTTL IN
T04	VCC	POWER	V16	VCC	POWER	Y16	VCC	POWER
T17	VCC	POWER	V17	RXDA[7]	LVTTTL OUT	Y17	TXERRD	LVTTTL OUT
T18	VCC	POWER	V18	RXDA[3]	LVTTTL OUT	Y18	REFCLKA-	PECL IN
T19	VCC	POWER	V19	RXDA[0]	LVTTTL OUT	Y19	RXDA[6]	LVTTTL OUT
T20	VCC	POWER	V20	RXSTA[0]	LVTTTL OUT	Y20	RXDA[5]	LVTTTL OUT
U01	TXDD[0]	LVTTTL IN	W01	TXDD[5]	LVTTTL IN			
U02	TXDD[1]	LVTTTL IN	W02	TXDD[7]	LVTTTL IN			

X3.230 Codes and Notation Conventions

Information transmitted over a serial link is encoded eight bits at a time into a 10-bit Transmission Character and then sent serially, bit by bit. Information received over a serial link is collected ten bits at a time, and those Transmission Characters that are used for data characters are decoded into the correct eight-bit codes. The 10-bit Transmission Code supports all 256 8-bit combinations. Some of the remaining Transmission Characters (Special Characters) are used for functions other than data transmission.

The primary use of a Transmission Code is to improve the transmission characteristics of a serial link. The encoding defined by the Transmission Code ensures that sufficient transitions are present in the serial bit stream to make clock recovery possible at the Receiver. Such encoding also greatly increases the likelihood of detecting any single or multiple bit errors that may occur during transmission and reception of information. In addition, some Special Characters of the Transmission Code selected by Fibre Channel Standard contain a distinct and easily recognizable bit pattern that assists the receiver in achieving character alignment on the incoming bit stream.

Notation Conventions

The documentation for the 8B/10B Transmission Code uses letter notation for the bits in an 8-bit byte. Fibre Channel Standard notation uses a bit notation of A, B, C, D, E, F, G, H for the 8-bit byte for the raw 8-bit data, and the letters a, b, c, d, e, i, f, g, h, j for encoded 10-bit data. There is a correspondence between bit A and bit a, B and b, C and c, D and d, E and e, F and f, G and g, and H and h. Bits i and j are derived, respectively, from (A,B,C,D,E) and (F,G,H).

The bit labeled A in the description of the 8B/10B Transmission Code corresponds to bit 0 in the numbering scheme of the FC-2 specification, B corresponds to bit 1, as shown below.

FC-2 bit designation—	7	6	5	4	3	2	1	0
HOTLink D/Q designation—	7	6	5	4	3	2	1	0
8B/10B bit designation—	H	G	F	E	D	C	B	A

To clarify this correspondence, the following example shows the conversion from an FC-2 Valid Data Byte to a Transmission Character.

```
FC-2  45H
      Bits: 7654 3210
           0100 0101
```

Converted to 8B/10B notation, note that the order of bits has been reversed):

```
Data Byte Name  D5.2
      Bits: ABCDE FGH
           10100 010
```

Translated to a transmission Character in the 8B/10B Transmission Code:

```
Bits: abcdei fghj
      101001 0101
```

Each valid Transmission Character of the 8B/10B Transmission Code has been given a name using the following convention: cxx.y, where c is used to show whether the Transmission Character is a Data Character (c is set to D, and SC/D

= LOW) or a Special Character (c is set to K, and SC/D = HIGH). When c is set to D, xx is the decimal value of the binary number composed of the bits E, D, C, B, and A in that order, and the y is the decimal value of the binary number composed of the bits H, G, and F in that order. When c is set to K, xx and y are derived by comparing the encoded bit patterns of the Special Character to those patterns derived from encoded Valid Data bytes and selecting the names of the patterns most similar to the encoded bit patterns of the Special Character.

Under the above conventions, the Transmission Character used for the examples above, is referred to by the name D5.2. The Special Character K29.7 is so named because the first six bits (abcdei) of this character make up a bit pattern similar to that resulting from the encoding of the unencoded 11101 pattern (29), and because the second four bits (fghj) make up a bit pattern similar to that resulting from the encoding of the unencoded 111 pattern (7).

Note. This definition of the 10-bit Transmission Code is based on the following references, which describe the same 10-bit transmission code.

A.X. Widmer and P.A. Franaszek. "A DC-Balanced, Partitioned-Block, 8B/10B Transmission Code" IBM Journal of Research and Development, 27, No. 5: 440-451 (September, 1983).

U.S. Patent 4,486,739. Peter A. Franaszek and Albert X. Widmer. "Byte-Oriented DC Balanced (0.4) 8B/10B Partitioned Block Transmission Code" (December 4, 1984).

Fibre Channel Physical and Signaling Interface (ANSI X3.230-1994 ANSI FC-PH Standard).

IBM Enterprise Systems Architecture/390 ESCON I/O Interface (document number SA22-7202).

8B/10B Transmission Code

The following information describes how the tables are used for both generating valid Transmission Characters (encoding) and checking the validity of received Transmission Characters (decoding). It also specifies the ordering rules followed when transmitting the bits within a character and the characters within any higher-level constructs specified by a standard.

Transmission Order

Within the definition of the 8B/10B Transmission Code, the bit positions of the Transmission Characters are labeled a, b, c, d, e, i, f, g, h, j. Bit "a" is transmitted first followed by bits b, c, d, e, i, f, g, h, and j in that order.

Note that bit i is transmitted between bit e and bit f, rather than in alphabetical order.

Valid and Invalid Transmission Characters

The following tables define the valid Data Characters and valid Special Characters (K characters), respectively. The tables are used for both generating valid Transmission Characters and checking the validity of received Transmission Characters. In the tables, each Valid-Data-byte or Special-Character-code entry has two columns that represent two Transmission Characters. The two columns correspond to the current value of the running disparity. Running disparity is a binary parameter with either a negative (-) or positive (+) value.

After powering on, the Transmitter may assume either a positive or negative value for its initial running disparity. Upon transmission of any Transmission Character, the transmitter selects the proper version of the Transmission Character based on the current running disparity value, and the Transmitter calculates a new value for its running disparity based on the contents of the transmitted character. Special Character codes C1.7 and C2.7 can be used to force the transmission of a specific Special Character with a specific running disparity as required for some special sequences in X3.230.

After powering on, the Receiver may assume either a positive or negative value for its initial running disparity. Upon reception of any Transmission Character, the Receiver decides whether the Transmission Character is valid or invalid according to the following rules and tables and calculates a new value for its Running Disparity based on the contents of the received character.

The following rules for running disparity are used to calculate the new running-disparity value for Transmission Characters that have been transmitted and received.

Running disparity for a Transmission Character is calculated from sub-blocks, where the first six bits (abcdei) form one sub-block and the second four bits (fghj) form the other sub-block. Running disparity at the beginning of the 6-bit sub-block is the running disparity at the end of the previous Transmission Character. Running disparity at the beginning of the 4-bit sub-block is the running disparity at the end of the 6-bit sub-block. Running disparity at the end of the Transmission Character is the running disparity at the end of the 4-bit sub-block.

Running disparity for the sub-blocks is calculated as follows:

1. Running disparity at the end of any sub-block is positive if the sub-block contains more ones than zeros. It is also positive at the end of the 6-bit sub-block if the 6-bit sub-block is 000111, and it is positive at the end of the 4-bit sub-block if the 4-bit sub-block is 0011.
2. Running disparity at the end of any sub-block is negative if the sub-block contains more zeros than ones. It is also negative at the end of the 6-bit sub-block if the 6-bit sub-block is 111000, and it is negative at the end of the 4-bit sub-block if the 4-bit sub-block is 1100.
3. Otherwise, running disparity at the end of the sub-block is the same as at the beginning of the sub-block.

Use of the Tables for Generating Transmission Characters

The appropriate entry in [Table 15](#) for the Valid Data byte or [Table 16](#) for Special Character byte identify which Transmission Character is generated. The current value of the Transmitter's running disparity is used to select the Transmission Character from its corresponding column. For each

Table 14.Code Violations Resulting from Prior Errors

	RD	Character	RD	Character	RD	Character	RD
Transmitted data character	–	D21.1	–	D10.2	–	D23.5	+
Transmitted bit stream	–	101010 1001	–	010101 0101	–	111010 1010	+
Bit stream after error	–	101010 1011	+	010101 0101	+	111010 1010	+
Decoded data character	–	D21.0	+	D10.2	+	Code Violation	+

Transmission Character transmitted, a new value of the running disparity is calculated. This new value is used as the Transmitter's current running disparity for the next Valid Data byte or Special Character byte encoded and transmitted. [Table 13](#) shows naming notations and examples of valid transmission characters.

Use of the Tables for Checking the Validity of Received Transmission Characters

The column corresponding to the current value of the Receiver's running disparity is searched for the received Transmission Character. If the received Transmission Character is found in the proper column, then the Transmission Character is valid and the associated Data byte or Special Character code is determined (decoded). If the received Transmission Character is not found in that column, then the Transmission Character is invalid. This is called a code violation. Independent of the Transmission Character's validity, the received Transmission Character is used to calculate a new value of running disparity. The new value is used as the Receiver's current running disparity for the next received Transmission Character.

Table 13.Valid Transmission Characters

Byte Name	Data		Hex Value
	D _{IN} or Q _{OUT}		
	765	43210	
D0.0	000	00000	00
D1.0	000	00001	01
D2.0	000	00010	02
.	.	.	.
.	.	.	.
D5.2	010	00101	45
.	.	.	.
.	.	.	.
D30.7	111	11110	FE
D31.7	111	11111	FF

Detection of a code violation does not necessarily show that the Transmission Character in which the code violation was detected is in error. Code violations may result from a prior error that altered the running disparity of the bit stream which did not result in a detectable error at the Transmission Character in which the error occurred. [Table 14](#) shows an example of this behavior.

Table 15. Valid Data Characters (TXCTx[0] = 0, RXSTx[2:0] = 000)

Data Byte Name	Bits	Current RD-	Current RD+	Data Byte Name	Bits	Current RD-	Current RD+
	HGF EDCBA	abcdei fgjh	abcdei fgjh		HGF EDCBA	abcdei fgjh	abcdei fgjh
D0.0	000 00000	100111 0100	011000 1011	D0.1	001 00000	100111 1001	011000 1001
D1.0	000 00001	011101 0100	100010 1011	D1.1	001 00001	011101 1001	100010 1001
D2.0	000 00010	101101 0100	010010 1011	D2.1	001 00010	101101 1001	010010 1001
D3.0	000 00011	110001 1011	110001 0100	D3.1	001 00011	110001 1001	110001 1001
D4.0	000 00100	110101 0100	001010 1011	D4.1	001 00100	110101 1001	001010 1001
D5.0	000 00101	101001 1011	101001 0100	D5.1	001 00101	101001 1001	101001 1001
D6.0	000 00110	011001 1011	011001 0100	D6.1	001 00110	011001 1001	011001 1001
D7.0	000 00111	111000 1011	000111 0100	D7.1	001 00111	111000 1001	000111 1001
D8.0	000 01000	111001 0100	000110 1011	D8.1	001 01000	111001 1001	000110 1001
D9.0	000 01001	100101 1011	100101 0100	D9.1	001 01001	100101 1001	100101 1001
D10.0	000 01010	010101 1011	010101 0100	D10.1	001 01010	010101 1001	010101 1001
D11.0	000 01011	110100 1011	110100 0100	D11.1	001 01011	110100 1001	110100 1001
D12.0	000 01100	001101 1011	001101 0100	D12.1	001 01100	001101 1001	001101 1001
D13.0	000 01101	101100 1011	101100 0100	D13.1	001 01101	101100 1001	101100 1001
D14.0	000 01110	011100 1011	011100 0100	D14.1	001 01110	011100 1001	011100 1001
D15.0	000 01111	010111 0100	101000 1011	D15.1	001 01111	010111 1001	101000 1001
D16.0	000 10000	011011 0100	100100 1011	D16.1	001 10000	011011 1001	100100 1001
D17.0	000 10001	100011 1011	100011 0100	D17.1	001 10001	100011 1001	100011 1001
D18.0	000 10010	010011 1011	010011 0100	D18.1	001 10010	010011 1001	010011 1001
D19.0	000 10011	110010 1011	110010 0100	D19.1	001 10011	110010 1001	110010 1001
D20.0	000 10100	001011 1011	001011 0100	D20.1	001 10100	001011 1001	001011 1001
D21.0	000 10101	101010 1011	101010 0100	D21.1	001 10101	101010 1001	101010 1001
D22.0	000 10110	011010 1011	011010 0100	D22.1	001 10110	011010 1001	011010 1001
D23.0	000 10111	111010 0100	000101 1011	D23.1	001 10111	111010 1001	000101 1001
D24.0	000 11000	110011 0100	001100 1011	D24.1	001 11000	110011 1001	001100 1001
D25.0	000 11001	100110 1011	100110 0100	D25.1	001 11001	100110 1001	100110 1001
D26.0	000 11010	010110 1011	010110 0100	D26.1	001 11010	010110 1001	010110 1001
D27.0	000 11011	110110 0100	001001 1011	D27.1	001 11011	110110 1001	001001 1001
D28.0	000 11100	001110 1011	001110 0100	D28.1	001 11100	001110 1001	001110 1001
D29.0	000 11101	101110 0100	010001 1011	D29.1	001 11101	101110 1001	010001 1001
D30.0	000 11110	011110 0100	100001 1011	D30.1	001 11110	011110 1001	100001 1001
D31.0	000 11111	101011 0100	010100 1011	D31.1	001 11111	101011 1001	010100 1001

Table 15. Valid Data Characters (TXCTx[0] = 0, RXSTx[2:0] = 000) (continued)

Data Byte Name	Bits	Current RD-	Current RD+	Data Byte Name	Bits	Current RD-	Current RD+
	HGF EDCBA	abcdei fghj	abcdei fghj		HGF EDCBA	abcdei fghj	abcdei fghj
D0.2	010 00000	100111 0101	011000 0101	D0.3	011 00000	100111 0011	011000 1100
D1.2	010 00001	011101 0101	100010 0101	D1.3	011 00001	011101 0011	100010 1100
D2.2	010 00010	101101 0101	010010 0101	D2.3	011 00010	101101 0011	010010 1100
D3.2	010 00011	110001 0101	110001 0101	D3.3	011 00011	110001 1100	110001 0011
D4.2	010 00100	110101 0101	001010 0101	D4.3	011 00100	110101 0011	001010 1100
D5.2	010 00101	101001 0101	101001 0101	D5.3	011 00101	101001 1100	101001 0011
D6.2	010 00110	011001 0101	011001 0101	D6.3	011 00110	011001 1100	011001 0011
D7.2	010 00111	111000 0101	000111 0101	D7.3	011 00111	111000 1100	000111 0011
D8.2	010 01000	111001 0101	000110 0101	D8.3	011 01000	111001 0011	000110 1100
D9.2	010 01001	100101 0101	100101 0101	D9.3	011 01001	100101 1100	100101 0011
D10.2	010 01010	010101 0101	010101 0101	D10.3	011 01010	010101 1100	010101 0011
D11.2	010 01011	110100 0101	110100 0101	D11.3	011 01011	110100 1100	110100 0011
D12.2	010 01100	001101 0101	001101 0101	D12.3	011 01100	001101 1100	001101 0011
D13.2	010 01101	101100 0101	101100 0101	D13.3	011 01101	101100 1100	101100 0011
D14.2	010 01110	011100 0101	011100 0101	D14.3	011 01110	011100 1100	011100 0011
D15.2	010 01111	010111 0101	101000 0101	D15.3	011 01111	010111 0011	101000 1100
D16.2	010 10000	011011 0101	100100 0101	D16.3	011 10000	011011 0011	100100 1100
D17.2	010 10001	100011 0101	100011 0101	D17.3	011 10001	100011 1100	100011 0011
D18.2	010 10010	010011 0101	010011 0101	D18.3	011 10010	010011 1100	010011 0011
D19.2	010 10011	110010 0101	110010 0101	D19.3	011 10011	110010 1100	110010 0011
D20.2	010 10100	001011 0101	001011 0101	D20.3	011 10100	001011 1100	001011 0011
D21.2	010 10101	101010 0101	101010 0101	D21.3	011 10101	101010 1100	101010 0011
D22.2	010 10110	011010 0101	011010 0101	D22.3	011 10110	011010 1100	011010 0011
D23.2	010 10111	111010 0101	000101 0101	D23.3	011 10111	111010 0011	000101 1100
D24.2	010 11000	110011 0101	001100 0101	D24.3	011 11000	110011 0011	001100 1100
D25.2	010 11001	100110 0101	100110 0101	D25.3	011 11001	100110 1100	100110 0011
D26.2	010 11010	010110 0101	010110 0101	D26.3	011 11010	010110 1100	010110 0011
D27.2	010 11011	110110 0101	001001 0101	D27.3	011 11011	110110 0011	001001 1100
D28.2	010 11100	001110 0101	001110 0101	D28.3	011 11100	001110 1100	001110 0011
D29.2	010 11101	101110 0101	010001 0101	D29.3	011 11101	101110 0011	010001 1100
D30.2	010 11110	011110 0101	100001 0101	D30.3	011 11110	011110 0011	100001 1100
D31.2	010 11111	101011 0101	010100 0101	D31.3	011 11111	101011 0011	010100 1100

Table 15. Valid Data Characters (TXCTx[0] = 0, RXSTx[2:0] = 000) (continued)

Data Byte Name	Bits	Current RD-	Current RD+	Data Byte Name	Bits	Current RD-	Current RD+
	HGF EDCBA	abcdei fghj	abcdei fghj		HGF EDCBA	abcdei fghj	abcdei fghj
D0.4	100 00000	100111 0010	011000 1101	D0.5	101 00000	100111 1010	011000 1010
D1.4	100 00001	011101 0010	100010 1101	D1.5	101 00001	011101 1010	100010 1010
D2.4	100 00010	101101 0010	010010 1101	D2.5	101 00010	101101 1010	010010 1010
D3.4	100 00011	110001 1101	110001 0010	D3.5	101 00011	110001 1010	110001 1010
D4.4	100 00100	110101 0010	001010 1101	D4.5	101 00100	110101 1010	001010 1010
D5.4	100 00101	101001 1101	101001 0010	D5.5	101 00101	101001 1010	101001 1010
D6.4	100 00110	011001 1101	011001 0010	D6.5	101 00110	011001 1010	011001 1010
D7.4	100 00111	111000 1101	000111 0010	D7.5	101 00111	111000 1010	000111 1010
D8.4	100 01000	111001 0010	000110 1101	D8.5	101 01000	111001 1010	000110 1010
D9.4	100 01001	100101 1101	100101 0010	D9.5	101 01001	100101 1010	100101 1010
D10.4	100 01010	010101 1101	010101 0010	D10.5	101 01010	010101 1010	010101 1010
D11.4	100 01011	110100 1101	110100 0010	D11.5	101 01011	110100 1010	110100 1010
D12.4	100 01100	001101 1101	001101 0010	D12.5	101 01100	001101 1010	001101 1010
D13.4	100 01101	101100 1101	101100 0010	D13.5	101 01101	101100 1010	101100 1010
D14.4	100 01110	011100 1101	011100 0010	D14.5	101 01110	011100 1010	011100 1010
D15.4	100 01111	010111 0010	101000 1101	D15.5	101 01111	010111 1010	101000 1010
D16.4	100 10000	011011 0010	100100 1101	D16.5	101 10000	011011 1010	100100 1010
D17.4	100 10001	100011 1101	100011 0010	D17.5	101 10001	100011 1010	100011 1010
D18.4	100 10010	010011 1101	010011 0010	D18.5	101 10010	010011 1010	010011 1010
D19.4	100 10011	110010 1101	110010 0010	D19.5	101 10011	110010 1010	110010 1010
D20.4	100 10100	001011 1101	001011 0010	D20.5	101 10100	001011 1010	001011 1010
D21.4	100 10101	101010 1101	101010 0010	D21.5	101 10101	101010 1010	101010 1010
D22.4	100 10110	011010 1101	011010 0010	D22.5	101 10110	011010 1010	011010 1010
D23.4	100 10111	111010 0010	000101 1101	D23.5	101 10111	111010 1010	000101 1010
D24.4	100 11000	110011 0010	001100 1101	D24.5	101 11000	110011 1010	001100 1010
D25.4	100 11001	100110 1101	100110 0010	D25.5	101 11001	100110 1010	100110 1010
D26.4	100 11010	010110 1101	010110 0010	D26.5	101 11010	010110 1010	010110 1010
D27.4	100 11011	110110 0010	001001 1101	D27.5	101 11011	110110 1010	001001 1010
D28.4	100 11100	001110 1101	001110 0010	D28.5	101 11100	001110 1010	001110 1010
D29.4	100 11101	101110 0010	010001 1101	D29.5	101 11101	101110 1010	010001 1010
D30.4	100 11110	011110 0010	100001 1101	D30.5	101 11110	011110 1010	100001 1010
D31.4	100 11111	101011 0010	010100 1101	D31.5	101 11111	101011 1010	010100 1010

Table 15. Valid Data Characters (TXCTx[0] = 0, RXSTx[2:0] = 000) (continued)

Data Byte Name	Bits	Current RD-	Current RD+	Data Byte Name	Bits	Current RD-	Current RD+
	HGF EDCBA	abcdei fghj	abcdei fghj		HGF EDCBA	abcdei fghj	abcdei fghj
D0.6	110 00000	100111 0110	011000 0110	D0.7	111 00000	100111 0001	011000 1110
D1.6	110 00001	011101 0110	100010 0110	D1.7	111 00001	011101 0001	100010 1110
D2.6	110 00010	101101 0110	010010 0110	D2.7	111 00010	101101 0001	010010 1110
D3.6	110 00011	110001 0110	110001 0110	D3.7	111 00011	110001 1110	110001 0001
D4.6	110 00100	110101 0110	001010 0110	D4.7	111 00100	110101 0001	001010 1110
D5.6	110 00101	101001 0110	101001 0110	D5.7	111 00101	101001 1110	101001 0001
D6.6	110 00110	011001 0110	011001 0110	D6.7	111 00110	011001 1110	011001 0001
D7.6	110 00111	111000 0110	000111 0110	D7.7	111 00111	111000 1110	000111 0001
D8.6	110 01000	111001 0110	000110 0110	D8.7	111 01000	111001 0001	000110 1110
D9.6	110 01001	100101 0110	100101 0110	D9.7	111 01001	100101 1110	100101 0001
D10.6	110 01010	010101 0110	010101 0110	D10.7	111 01010	010101 1110	010101 0001
D11.6	110 01011	110100 0110	110100 0110	D11.7	111 01011	110100 1110	110100 1000
D12.6	110 01100	001101 0110	001101 0110	D12.7	111 01100	001101 1110	001101 0001
D13.6	110 01101	101100 0110	101100 0110	D13.7	111 01101	101100 1110	101100 1000
D14.6	110 01110	011100 0110	011100 0110	D14.7	111 01110	011100 1110	011100 1000
D15.6	110 01111	010111 0110	101000 0110	D15.7	111 01111	010111 0001	101000 1110
D16.6	110 10000	011011 0110	100100 0110	D16.7	111 10000	011011 0001	100100 1110
D17.6	110 10001	100011 0110	100011 0110	D17.7	111 10001	100011 0111	100011 0001
D18.6	110 10010	010011 0110	010011 0110	D18.7	111 10010	010011 0111	010011 0001
D19.6	110 10011	110010 0110	110010 0110	D19.7	111 10011	110010 1110	110010 0001
D20.6	110 10100	001011 0110	001011 0110	D20.7	111 10100	001011 0111	001011 0001
D21.6	110 10101	101010 0110	101010 0110	D21.7	111 10101	101010 1110	101010 0001
D22.6	110 10110	011010 0110	011010 0110	D22.7	111 10110	011010 1110	011010 0001
D23.6	110 10111	111010 0110	000101 0110	D23.7	111 10111	111010 0001	000101 1110
D24.6	110 11000	110011 0110	001100 0110	D24.7	111 11000	110011 0001	001100 1110
D25.6	110 11001	100110 0110	100110 0110	D25.7	111 11001	100110 1110	100110 0001
D26.6	110 11010	010110 0110	010110 0110	D26.7	111 11010	010110 1110	010110 0001
D27.6	110 11011	110110 0110	001001 0110	D27.7	111 11011	110110 0001	001001 1110
D28.6	110 11100	001110 0110	001110 0110	D28.7	111 11100	001110 1110	001110 0001
D29.6	110 11101	101110 0110	010001 0110	D29.7	111 11101	101110 0001	010001 1110
D30.6	110 11110	011110 0110	100001 0110	D30.7	111 11110	011110 0001	100001 1110
D31.6	110 11111	101011 0110	010100 0110	D31.7	111 11111	101011 0001	010100 1110

Table 16. Valid Special Character Codes and Sequences (TXCTx = special character code or RXSTx[2:0] = 001)^[40, 41]

S.C. Code Name	S.C. Byte Name					Current RD– abcdei fghj	Current RD+ abcdei fghj
	Cypress			Alternate			
	S.C. Byte Name [42]	Bits HGF EDCBA	S.C. Byte Name [42]	Bits HGF EDCBA			
K28.0	C0.0 (C00)	000 00000	C28.0 (C1C)	000 11100	001111 0100	110000 1011	
K28.1 ^[43]	C1.0 (C01)	000 00001	C28.1 (C3C)	001 11100	001111 1001	110000 0110	
K28.2 ^[43]	C2.0 (C02)	000 00010	C28.2 (C5C)	010 11100	001111 0101	110000 1010	
K28.3	C3.0 (C03)	000 00011	C28.3 (C7C)	011 11100	001111 0011	110000 1100	
K28.4 ^[43]	C4.0 (C04)	000 00100	C28.4 (C9C)	100 11100	001111 0010	110000 1101	
K28.5 ^[43, 44]	C5.0 (C05)	000 00101	C28.5 (CBC)	101 11100	001111 1010	110000 0101	
K28.6 ^[43]	C6.0 (C06)	000 00110	C28.6 (CDC)	110 11100	001111 0110	110000 1001	
K28.7 ^[43, 45]	C7.0 (C07)	000 00111	C28.7 (CFC)	111 11100	001111 1000	110000 0111	
K23.7	C8.0 (C08)	000 01000	C23.7 (CF7)	111 10111	111010 1000	000101 0111	
K27.7	C9.0 (C09)	000 01001	C27.7 (CFB)	111 11011	110110 1000	001001 0111	
K29.7	C10.0 (C0A)	000 01010	C29.7 (CFD)	111 11101	101110 1000	010001 0111	
K30.7	C11.0 (C0B)	000 01011	C30.7 (CFE)	111 11110	011110 1000	100001 0111	
End of Frame Sequence							
EOFxx	C2.1 (C22)	001 00010	C2.1 (C22)	001 00010	–K28.5,Dn.xxx0 ^[46]	+K28.5,Dn.xxx1 ^[46]	
Code Rule Violation and SVS Tx Pattern							
Exception ^[45, 47]	C0.7 (CE0)	111 00000	C0.7 (CE0)	111 00000	100111 1000	011000 0111	
–K28.5 ^[48]	C1.7 (CE1)	111 00001	C1.7 (CE1)	111 00001	001111 1010	001111 1010	
+K28.5 ^[49]	C2.7 (CE2)	111 00010	C2.7 (CE2)	111 00010	110000 0101	110000 0101	
Running Disparity Violation Pattern							
Exception ^[50]	C4.7 (CE4)	111 00100	C4.7 (CE4)	111 00100	110111 0101	001000 1010	

Notes

40. All codes not shown are reserved.
41. Notation for Special Character Code Name is consistent with Fibre Channel and ESCON naming conventions. Special Character Code Name is intended to describe binary information present on I/O pins. Common usage for the name can either be in the form used for describing Data patterns (i.e., C0.0 through C31.7), or in hex notation (i.e., Cnn where nn = the specified value between 00 and FF).
42. Both the Cypress and alternate encodings may be used for data transmission to generate specific Special Character Codes. The decoding process for received characters generates Cypress codes or Alternate codes as selected by the BOE[7:0] configuration inputs.
43. These characters are used for control of ESCON interfaces. They can be sent as embedded commands or other markers when not operating using ESCON protocols.
44. The K28.5 character is used for framing operations by the receiver. It is also the pad or fill character transmitted to maintain the serial link when no user data is available.
45. Care must be taken when using this Special Character code. When a C7.0 or a C0.7 is followed by a D11.x or D20.x, an alias K28.5 sync character is created. These sequences can cause erroneous framing and should be avoided while RFENx = 1.
46. C2.1 = Transmit either –K28.5+ or +K28.5– as determined by Current RD and modify the Transmission Character that follows, by setting its least significant bit to 1 or 0. If Current RD at the start of the following character is plus (+) the LSB is set to 0, and if Current RD is minus (–) the LSB becomes 1. This modification allows construction of X3.230 “EOF” frame delimiters wherein the second data byte is determined by the Current RD. For example, to send “EOFdt” the controller could issue the sequence C2.1–D21.4– D21.4–D21.4, and the HOTLink Transmitter sends either K28.5–D21.4–D21.4–D21.4 or K28.5–D21.5– D21.4–D21.4 based on Current RD. Likewise to send “EOFdti” the controller could issue the sequence C2.1–D10.4–D21.4–D21.4, and the HOTLink Transmitter sends either K28.5–D10.4–D21.4– D21.4 or K28.5–D10.5–D21.4–D21.4 based on Current RD. The receiver never outputs this Special Character, since K28.5 is decoded as C5.0, C1.7, or C2.7, and the subsequent bytes are decoded as data.
47. C0.7 = Transmit a deliberate code rule violation. The code chosen for this function follows the normal Running Disparity rules. Transmission of this Special Character has the same effect as asserting TXSVS = HIGH. The receiver only outputs this Special Character if the Transmission Character being decoded is not found in the tables.
48. C1.7 = Transmit Negative K28.5 (–K28.5+) disregarding Current RD. The receiver only outputs this Special Character if K28.5 is received with the wrong running disparity. The receiver outputs C1.7 if –K28.5 is received with RD+, otherwise K28.5 is decoded as C5.0 or C2.7.
49. C2.7 = Transmit Positive K28.5 (+K28.5–) disregarding Current RD. The receiver only outputs this Special Character if K28.5 is received with the wrong running disparity. The receiver outputs C2.7 if +K28.5 is received with RD–, otherwise K28.5 is decoded as C5.0 or C1.7.
50. C4.7 = Transmit a deliberate code rule violation to indicate a Running Disparity violation. The receiver only outputs this Special Character if the Transmission Character being decoded is found in the tables, but Running Disparity does not match. This might indicate that an error occurred in a prior byte.

Ordering Information

Speed	Ordering Code	Package Name	Package Type	Operating Range
Standard	CYP15G0403DXB-BGC	BL256	256-Ball Thermally Enhanced Ball Grid Array	Commercial
Standard	CYP15G0403DXB-BGI	BL256	256-Ball Thermally Enhanced Ball Grid Array	Industrial
Standard	CYV15G0403DXB-BGC	BL256	256-Ball Thermally Enhanced Ball Grid Array	Commercial
Standard	CYV15G0403DXB-BGI	BL256	256-Ball Thermally Enhanced Ball Grid Array	Industrial
OBSAI	CYW15G0403DXB-BGC	BL256	256-Ball Thermally Enhanced Ball Grid Array	Commercial
OBSAI	CYW15G0403DXB-BGI	BL256	256-Ball Thermally Enhanced Ball Grid Array	Industrial
Standard	CYP15G0403DXB-BGXC	BL256	Pb-Free 256-Ball Thermally Enhanced Ball Grid Array	Commercial
Standard	CYP15G0403DXB-BGXI	BL256	Pb-Free 256-Ball Thermally Enhanced Ball Grid Array	Industrial
Standard	CYV15G0403DXB-BGXC	BL256	Pb-Free 256-Ball Thermally Enhanced Ball Grid Array	Commercial
Standard	CYV15G0403DXB-BGXI	BL256	Pb-Free 256-Ball Thermally Enhanced Ball Grid Array	Industrial
OBSAI	CYW15G0403DXB-BGXC	BL256	Pb-Free 256-Ball Thermally Enhanced Ball Grid Array	Commercial
OBSAI	CYW15G0403DXB-BGXI	BL256	Pb-Free 256-Ball Thermally Enhanced Ball Grid Array	Industrial

Package Diagram

Figure 3. 256-Lead L2 Ball Grid Array (27 x 27 x 1.57 mm) BL256

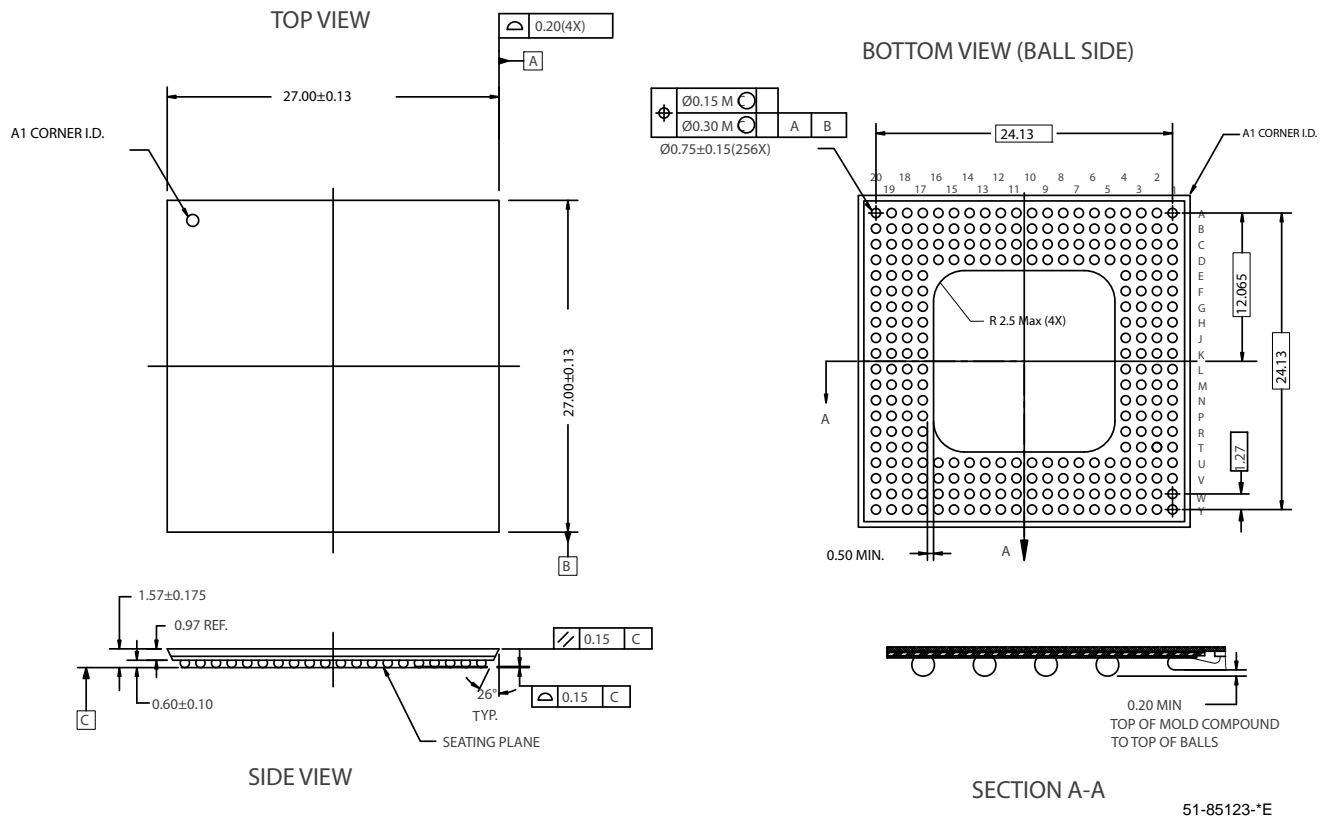

HOTLink is a registered trademark and HOTLink II and MultiFrame are trademarks of Cypress Semiconductor. CPRI is a trademark of Siemens AG. IBM and ESCON are registered trademarks, and FICON is a trademark, of International Business Machines. All product and company names mentioned in this document may be the trademarks of their respective holders.

Document History Page

Document Title: CYP(V)(W)15G0403DXB Independent Clock Quad HOTLink II™ Transceiver Document Number: 38-02065				
REV.	ECN NO.	ISSUE DATE	ORIG. OF CHANGE	DESCRIPTION OF CHANGE
**	118422	09/24/02	LNМ	New Data Sheet
*A	125289	04/04/03	CGX	Revised entire data sheet Redefined device
*B	128692	08/14/03	PDS	Provided AC timing information for TXERRx Added additional information regarding the availability of half-rate RXCLKx± when REFCLKx is a full-rate clock with RXCKSELx = 1 Added influence of ULCx input on LFLx status Added influence of DECMODEx on decoder bypass Revised the text for "Device Configuration and Control Interface" for better clarity Removed the timing parameter t _{RREFDV} and added the timing parameter t _{RREFDW} instead. This change was done to provide a more meaningful timing parameter Revised t _{RREFDA} from 9.5 ns to 9.7 ns Added additional information to "Device Configuration Strategy"
*C	234390	See ECN	PDS	Removed dependence of DECMODEx on decoder bypass. Revised AC timing parameters (AC Electrical Characteristics) to match final device characterization. Expanded the CDR Range Controller's permissible frequency offset between incoming serial signalling rate and Reference clock from ±200-PPM to ±1500-PPM (changed parameter t _{REFRX}).
*D	338721	See ECN	SUA	Added CYW15G0403DXB part number for OBSAI RP3 compliance to support operating data rate up to 1540 MBaud. Made changes to reflect OBSAI RP3 and CPR compliance. Added Pb-Free Package option for all parts listed in the data sheet. Modified Timing Parameters Changed MBd to MBaud in SPDSEL pin description
*E	384307	See ECN	AGT	Revised setup and hold time parameters (t _{TXDH} , t _{TREFDS} , t _{TREFDH} , t _{RXDv-} , t _{RXDv+} , t _{RXDv+} , t _{REFxDV-} , t _{REFxDV+})
*F	1034001	See ECN	UKK	Added clarification for the necessity of JTAG controller reset and the methods to implement it.

Компания «Океан Электроники» предлагает заключение долгосрочных отношений при поставках импортных электронных компонентов на взаимовыгодных условиях!

Наши преимущества:

- Поставка оригинальных импортных электронных компонентов напрямую с производств Америки, Европы и Азии, а так же с крупнейших складов мира;
- Широкая линейка поставок активных и пассивных импортных электронных компонентов (более 30 млн. наименований);
- Поставка сложных, дефицитных, либо снятых с производства позиций;
- Оперативные сроки поставки под заказ (от 5 рабочих дней);
- Экспресс доставка в любую точку России;
- Помощь Конструкторского Отдела и консультации квалифицированных инженеров;
- Техническая поддержка проекта, помощь в подборе аналогов, поставка прототипов;
- Поставка электронных компонентов под контролем ВП;
- Система менеджмента качества сертифицирована по Международному стандарту ISO 9001;
- При необходимости вся продукция военного и аэрокосмического назначения проходит испытания и сертификацию в лаборатории (по согласованию с заказчиком);
- Поставка специализированных компонентов военного и аэрокосмического уровня качества (Xilinx, Altera, Analog Devices, Intersil, Interpoint, Microsemi, Actel, Aeroflex, Peregrine, VPT, Syfer, Eurofarad, Texas Instruments, MS Kennedy, Miteq, Cobham, E2V, MA-COM, Hittite, Mini-Circuits, General Dynamics и др.);

Компания «Океан Электроники» является официальным дистрибьютором и эксклюзивным представителем в России одного из крупнейших производителей разъемов военного и аэрокосмического назначения «JONHON», а так же официальным дистрибьютором и эксклюзивным представителем в России производителя высокотехнологичных и надежных решений для передачи СВЧ сигналов «FORSTAR».



JONHON

«JONHON» (основан в 1970 г.)

Разъемы специального, военного и аэрокосмического назначения:

(Применяются в военной, авиационной, аэрокосмической, морской, железнодорожной, горно- и нефтедобывающей отраслях промышленности)

«FORSTAR» (основан в 1998 г.)

ВЧ соединители, коаксиальные кабели,
кабельные сборки и микроволновые компоненты:

(Применяются в телекоммуникациях гражданского и специального назначения, в средствах связи, РЛС, а так же военной, авиационной и аэрокосмической отраслях промышленности).



Телефон: 8 (812) 309-75-97 (многоканальный)

Факс: 8 (812) 320-03-32

Электронная почта: ocean@oceanchips.ru

Web: <http://oceanchips.ru/>

Адрес: 198099, г. Санкт-Петербург, ул. Калинина, д. 2, корп. 4, лит. А