

PRODUCT NUMBER  
SEE TABLE

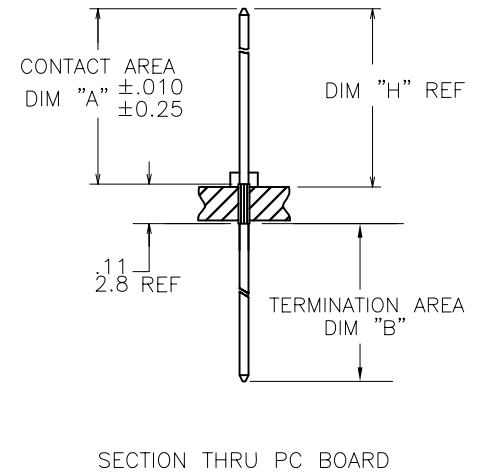

mat'l. code SEE NOTE 1		surface ASME Y14.5		tolerance ASME Y14.5		projection		product family PIN PRODUCTS	
ltr	ecm no	dr	date	tolerances unless otherwise specified		INCH/MM		title	
L	V01594	JRW	2000-07-18	angles	XX*.01/X*.3	INCH/MM		BERGPIN® .200"[5.08]cc	
M	V02315	LSS	2000-09-18	fin	XXX*.005/XXX*.18	scale 2:1		.041"[1.04] DIA., .110"[2.79] LONG STAR WITH SOLDER WASHER	
N	V06-0682	JRV	2006-07-19	0° ±2'	XXXX*.0020/XXX*.051			dwg no	
P	V08-0354	HTB	2008-08-26	dr	M. CORNMAN	1991-02-07		sheet 1 of 4	
				engr	S. AURAND	1991-02-07		size	
				chr	S. AURAND	1991-02-07		A4	
				appd	S. AURAND	1991-02-07		type	
sheet index	revision sheet	P	P	P	P			CUSTOMER Drawing	
		1	2	3	4				

PRODUCT NUMBER  
SEE TABLE

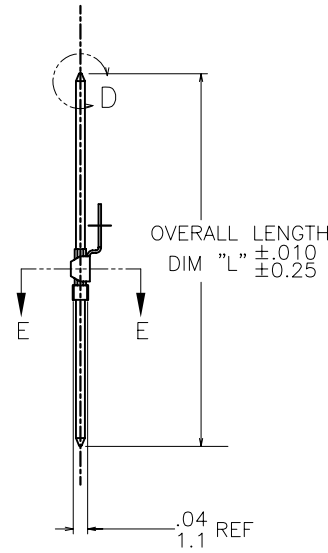
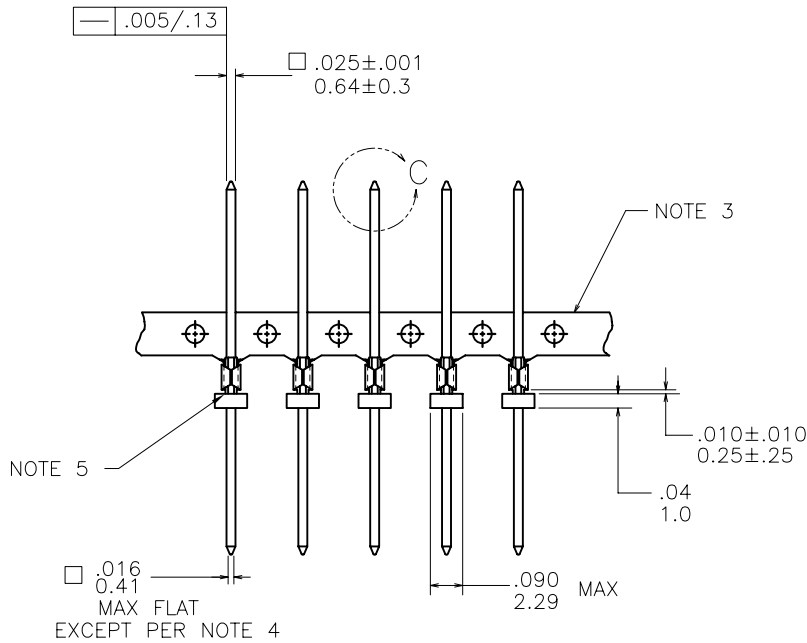
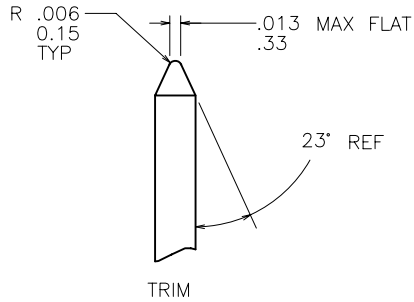

DETAIL C  
SCALE: 10/1  
TYP BOTH ENDS

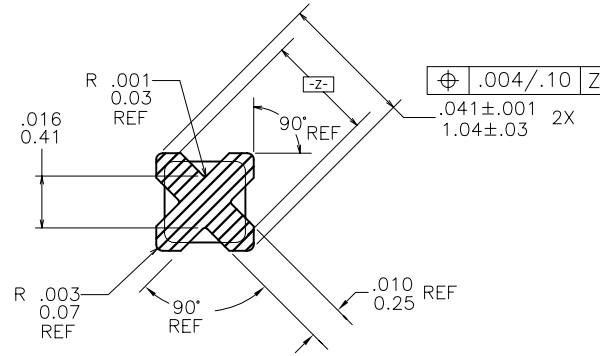

SECTION E-E  
SCALE: 20/1  
(FERRULE REMOVED)

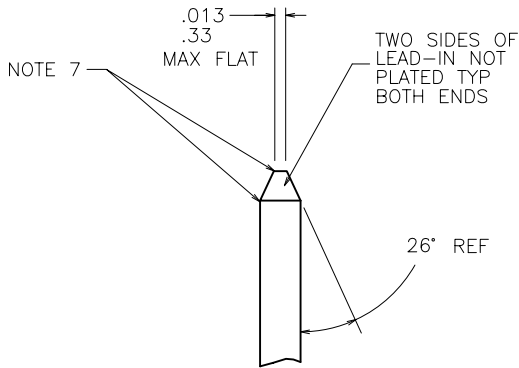

DETAIL D  
SCALE: 10/1  
TYP BOTH ENDS

NOTES:

- ① PIN MATERIAL: 3/4 HARD PHOS BRONZE  
ASTM B-159-66
2. SEE PRODUCT SPECIFICATION BUS-12-064 FOR P.C. BOARD HOLE DIAMETER AND P.C. BOARD PLATING INFORMATION.
- ③ FOR MANUFACTURING PURPOSES ONLY.
- ④ DOUBLE ENDED PINS AS MARKED MUST MEET SPECS IN VIEWS C AND D ON BOTH ENDS. OTHERS TO HAVE .016 [0.41] MAX DIM ON BOTTOM END OF PIN.
- ⑤ SOLDER MAY BULGE IN THIS AREA BUT WILL NOT TOUCH FERRULE.
6. "A" DIM. IS TO FEATURE ON PIN.  
"H" DIM. IS ABOVE BOARD.  
"B" DIM. IS TO FEATURE ON PIN.
- ⑦ BURNISH MARKS ON PIN PERMITTED.  
BURR: .003 [0.08] MAX, BULGE: .0005 [.013] MAX TYP.

mat'l. code SEE NOTE 1		surface ASME Y14.5	tolerance ASME Y14.5	projection	product family PIN PRODUCTS
ltr	ecn no	dr	date	tolerances unless otherwise specified	title
P				angles XX*.01/X*.3 XXX*.005/XXX*.13	BERGPIN® .200*[5.08]cc .041*[1.04] DIA., .110*[2.79] LONG STAR WITH SOLDER WASHER
				0° ±2° XXXX*.0020/XXX*.051	scale 1:1
		dr	M. CORNMAN	1991-02-06	dwg no
		engr	S. AURAND	1991-02-06	76644
		chr	S. AURAND	1991-02-06	sheet 2 of 4
		appd	S. AURAND	1991-02-06	size A4
sheet index	revision sheet				type CUSTOMER Drawing



PRODUCT NUMBER	CONTACT AREA		TERM. AREA		DIM H FOR .093/2.36 BOARD		DIM H FOR .125/3.18 BOARD		OVERALL LENGTH		NOTE 4
	DIM A	DIM A	DIM B	DIM B	ENGLISH	METRIC	ENGLISH	METRIC	ENGLISH	METRIC	
	ENGLISH	METRIC	ENGLISH	METRIC	ENGLISH	METRIC	ENGLISH	METRIC	ENGLISH	METRIC	
76644-X01	0.240	6.10	0.040	1.02	0.248	6.30	0.232	5.89	0.390	9.91	-
76644-X02	0.270	6.86	0.040	1.02	0.278	7.06	0.262	6.65	0.420	10.67	-
76644-X03	0.245	6.22	0.073	1.85	0.253	6.43	0.237	6.02	0.430	10.92	-
76644-X04	0.290	7.37	0.040	1.02	0.298	7.57	0.282	7.16	0.440	11.18	-
76644-X05	0.310	7.87	0.040	1.02	0.318	8.08	0.302	7.67	0.460	11.68	-
76644-X06	0.330	8.38	0.040	1.02	0.338	8.59	0.322	8.18	0.480	12.19	-
76644-X07	0.335	8.51	0.055	1.40	0.343	8.71	0.327	8.31	0.500	12.70	-
76644-X08	0.310	7.87	0.090	2.29	0.318	8.08	0.302	7.67	0.510	12.95	YES
76644-X09	0.365	9.27	0.042	1.07	0.373	9.47	0.357	9.07	0.517	13.13	-
76644-X10	0.310	7.87	0.120	3.05	0.318	8.08	0.302	7.67	0.540	13.72	YES
76644-X11	0.390	9.91	0.040	1.02	0.398	10.11	0.382	9.70	0.540	13.72	-
76644-X12	0.450	11.43	0.040	1.02	0.458	11.63	0.442	11.23	0.600	15.24	-
76644-X13	0.365	9.27	0.135	3.43	0.373	9.47	0.357	9.07	0.610	15.49	YES
76644-X14	0.468	11.89	0.042	1.07	0.476	12.09	0.460	11.68	0.620	15.75	-
76644-X15	0.658	16.71	0.042	1.07	0.666	16.92	0.650	16.51	0.810	20.57	-
76644-X16	0.720	18.29	0.040	1.02	0.728	18.49	0.712	18.08	0.870	22.10	-
76644-X17	0.275	6.99	0.255	6.48	0.283	7.19	0.267	6.78	0.640	16.26	YES
76644-X18	0.365	9.27	0.055	1.40	0.373	9.47	0.357	9.07	0.530	13.46	-
76644-X19	0.403	10.24	0.315	8.00	0.411	10.44	0.395	10.03	0.828	21.03	YES
76644-X20	0.591	15.01	0.315	8.00	0.599	15.21	0.583	14.81	1.016	25.81	YES
76644-X21	0.275	6.99	0.179	4.55	0.283	7.19	0.267	6.78	0.564	14.33	YES
76644-X22	0.585	14.86	0.240	6.10	0.593	15.06	0.577	14.66	0.940	23.88	YES
76644-X23	0.190	4.83	0.045	1.14	0.198	5.03	0.182	4.62	0.345	8.76	-
76644-X24	0.535	13.59	0.045	1.14	0.543	13.79	0.527	13.39	0.690	17.53	-
76644-X25	0.358	9.09	0.382	9.70	0.366	9.30	0.350	8.89	0.850	21.59	-
76644-X26	0.585	14.86	0.355	9.02	0.593	15.06	0.577	14.66	1.050	26.67	-
76644-X27			U N A	S S I G	N E D						
76644-X28			U N A	S S I G	N E D						
76644-X29	0.715	18.16	0.337	8.56	0.723	18.36	0.707	17.96	1.162	29.51	-
76644-X30	0.485	12.32	0.105	2.67	0.493	12.52	0.477	12.12	0.700	17.78	YES

PART NUMBER	PLATING	UNDERPLATING
76644-1YY	30μ" [0.76μ] MIN Au	50μ" [1.27μ] MIN Ni
76644-2YY	U N A S S I G N E D	
76644-3YY	50μ" [1.27μ] MIN Au	50μ" [1.27μ] MIN Ni
76644-4YY	120μ" [3.05μ] MIN 93/7 SnPb	50μ" [1.27μ] MIN Ni
76644-5YY	30μ" [0.76μ] MIN GXT™	50μ" [1.27μ] MIN Ni
76644-6YY	15μ" [0.38μ] MIN GXT™	50μ" [1.27μ] MIN Ni
76644-7YY	U N A S S I G N E D	
76644-8YY	U N A S S I G N E D	
76644-9YY	15μ" [0.38μ] MIN Au	50μ" [1.27μ] MIN Ni

A

A

B

B

mat'l. code		surface	tolerance	projection	product family
SEE NOTE 1		ASME Y14.5	ASME Y14.5		PIN PRODUCTS
ltr	ecn no	dr	date	title	
P				BERGPIN® .200"[5.08]cc	
				.041"[1.04] DIA., .110"[2.79] LONG STAR	
				WITH SOLDER WASHER	
				scale 1:1	dwg no
					sheet 3 of 4
					size
					76644
					A4
					type
					CUSTOMER Drawing
sheet index	revision				
	sheet				



PRODUCT NUMBER	CONTACT AREA		TERM. AREA		DIM H FOR .093/2.36 BOARD		DIM H FOR .125/3.18 BOARD		OVERALL LENGTH		NOTE 4
	DIM A	DIM A	DIM B	DIM B	ENGLISH	METRIC	ENGLISH	METRIC	ENGLISH	METRIC	
76644-X31	0.585	14.86	0.105	2.67	0.593	15.06	0.577	14.66	0.800	20.32	YES
76644-X32	0.258	6.55	0.052	1.32	0.266	6.76	0.250	6.35	0.420	10.67	-
76644-X33	0.360	9.14	0.040	1.02	0.368	9.35	0.352	8.94	0.510	12.95	-
76644-X34	0.430	10.92	0.040	1.02	0.438	11.13	0.422	10.72	0.580	14.73	-
76644-X35	0.470	11.94	0.460	11.68	0.478	12.14	0.462	11.73	1.040	26.42	YES
76644-X36	0.310	7.87	0.270	6.86	0.318	8.08	0.302	7.67	0.690	17.53	YES
76644-X37	0.408	10.36	0.042	1.07	0.416	10.57	0.400	10.16	0.560	14.22	-
76644-X38	0.188	4.78	0.042	1.07	0.196	4.98	0.180	4.57	0.340	8.64	-
76644-X39	0.590	14.99	0.040	1.02	0.598	15.19	0.582	14.78	0.740	18.80	-
76644-X40	0.248	6.30	0.042	1.07	0.256	6.50	0.240	6.10	0.400	10.16	-
76644-X41	0.268	6.81	0.142	3.61	0.276	7.01	0.260	6.60	0.520	13.21	-
76644-X42	0.310	7.87	0.170	4.32	0.318	8.08	0.302	7.67	0.590	14.99	-
76644-X43	0.268	6.81	0.212	5.38	0.278	7.06	0.262	6.65	0.590	14.99	-
76644-X44	0.340	8.64	0.130	3.30	0.348	8.84	0.332	8.43	0.580	14.73	-
76644-X45	0.300	7.62	0.340	8.64	0.308	7.82	0.292	7.42	0.750	19.05	YES
76644-X46	0.300	7.62	0.610	15.49	0.308	7.82	0.292	7.42	1.020	25.91	YES
76644-X47	0.330	8.38	0.370	9.40	0.338	8.59	0.322	8.18	0.810	20.57	YES
76644-X48	0.680	17.27	0.360	9.14	0.688	17.48	0.672	17.07	1.150	29.21	YES
76644-X49	0.560	55.00	0.040	1.02	0.568	14.43	0.552	14.02	0.710	18.03	-
76644-X50	0.690	17.53	0.040	1.02	0.698	17.73	0.682	17.32	0.840	21.34	-
76644-X51	0.567	14.40	0.256	6.50	0.575	14.61	0.559	14.20	0.933	23.70	YES
76644-X52	0.360	9.14	0.310	7.87	0.368	9.35	0.352	8.94	0.780	19.81	-
76644-X53	0.526	13.36	0.526	13.36	0.534	13.56	0.518	13.16	1.162	29.51	-
76644-X54	0.510	12.95	0.075	1.91	0.518	13.16	0.502	12.75	0.695	17.65	-
76644-X55	0.705	17.91	0.040	1.02	0.713	18.11	0.697	17.70	0.855	21.72	-
76644-X56	0.230	5.84	0.235	5.97	0.238	6.05	0.222	5.64	0.575	14.61	-
76644-X57	0.976	24.79	0.292	7.42	0.984	24.99	0.968	24.59	1.378	35.00	-
76644-X58	0.515	13.08	0.040	1.02	0.523	13.28	0.507	12.88	0.665	16.89	-

A

A

B

B

mat'l. code		surface		tolerance		projection		product family	
SEE NOTE 1		ASME Y14.5		ASME Y14.5				PIN PRODUCTS	
ltr	ecn no	dr	date	tolerances unless otherwise specified				title	
P				angles	$XX+01/XX+3$	INCH/MM		BERGPIN® .200"[5.08]cc	
					$XXX+005/XXX+13$	scale 1:1		.041"[1.04] DIA., .110"[2.79] LONG STAR WITH SOLDER WASHER	
				$0' \pm 2'$	$XXXX+0020/XXX+051$			dwg no	
				dr	T. BREWBAKER	1996-07-29		sheet 4 of 4	
				enr	L. FYE	1996-07-29		size	
				chr	T. BREWBAKER	1996-07-29		76644	
				appd	L. FYE	1996-07-29		A4	
sheet index	revision sheet							type CUSTOMER Drawing	

Компания «Океан Электроники» предлагает заключение долгосрочных отношений при поставках импортных электронных компонентов на взаимовыгодных условиях!

Наши преимущества:

- Поставка оригинальных импортных электронных компонентов напрямую с производств Америки, Европы и Азии, а так же с крупнейших складов мира;
- Широкая линейка поставок активных и пассивных импортных электронных компонентов (более 30 млн. наименований);
- Поставка сложных, дефицитных, либо снятых с производства позиций;
- Оперативные сроки поставки под заказ (от 5 рабочих дней);
- Экспресс доставка в любую точку России;
- Помощь Конструкторского Отдела и консультации квалифицированных инженеров;
- Техническая поддержка проекта, помощь в подборе аналогов, поставка прототипов;
- Поставка электронных компонентов под контролем ВП;
- Система менеджмента качества сертифицирована по Международному стандарту ISO 9001;
- При необходимости вся продукция военного и аэрокосмического назначения проходит испытания и сертификацию в лаборатории (по согласованию с заказчиком);
- Поставка специализированных компонентов военного и аэрокосмического уровня качества (Xilinx, Altera, Analog Devices, Intersil, Interpoint, Microsemi, Actel, Aeroflex, Peregrine, VPT, Syfer, Eurofarad, Texas Instruments, MS Kennedy, Miteq, Cobham, E2V, MA-COM, Hittite, Mini-Circuits, General Dynamics и др.);

Компания «Океан Электроники» является официальным дистрибьютором и эксклюзивным представителем в России одного из крупнейших производителей разъемов военного и аэрокосмического назначения «JONHON», а так же официальным дистрибьютором и эксклюзивным представителем в России производителя высокотехнологичных и надежных решений для передачи СВЧ сигналов «FORSTAR».



## JONHON

«JONHON» (основан в 1970 г.)

Разъемы специального, военного и аэрокосмического назначения:

(Применяются в военной, авиационной, аэрокосмической, морской, железнодорожной, горно- и нефтедобывающей отраслях промышленности)

«FORSTAR» (основан в 1998 г.)

ВЧ соединители, коаксиальные кабели, кабельные сборки и микроволновые компоненты:

(Применяются в телекоммуникациях гражданского и специального назначения, в средствах связи, РЛС, а так же военной, авиационной и аэрокосмической отраслях промышленности).



Телефон: 8 (812) 309-75-97 (многоканальный)

Факс: 8 (812) 320-03-32

Электронная почта: [ocean@oceanchips.ru](mailto:ocean@oceanchips.ru)

Web: <http://oceanchips.ru/>

Адрес: 198099, г. Санкт-Петербург, ул. Калинина, д. 2, корп. 4, лит. А