

## 36 Outputs VFD Controller/Driver

### ■ GENERAL DESCRIPTION

The NJU3427 is a 36-output VFD (Vacuum Fluorescent Display) controller/driver.

The NJU3427 consists of high-voltage driving circuit, Timing/ Segment driver select circuit, display data RAM (DDRAM), address counter, instruction register, reset circuit serial interface and oscillator.

The direct control from the MPU and high voltage drivers make the NJU3427 well suited for various VFD displays

### ■ Package

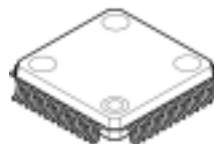

NJU3427FA2

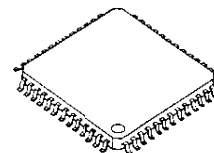

NJU3427FH2

### ■ FEATURES

- Display Capability From 20-Seg x16-Timing to 28-Seg x 4-Timing
- DR0 Pin ( $I_{S01}$ ) 20mA ( $V_{DD}=5V$ )
- DR1~DR35 Pins ( $I_{S02}$ ) 10mA ( $V_{DD}=5V$ )
- Segment and Timing Driver Configure 4 patterns
- High VFD Driving Voltage  $|V_{DD}-V_{FDP}| \leq 40V$
- Programmable Display Duty Ratio 1/4, 1/8, 1/12 or 1/16
- Programmable Timing Signal Duty Ratio 2/16, 4/16, 6/16, 8/16, 10/16, 12/16, 14/16, 15/16
- Display ON/OFF
- Display Data RAM 47x8 bits
- CR Oscillator External CR and capable of clock input from outside
- Serial Data Transfer Clock frequency: 2MHz Max.
- Logic Power Supply 3.0V / 5.0V
- C-MOS
- Package QFP52-A2, QFP52-H2

### ■ BLOCK DIAGRAM

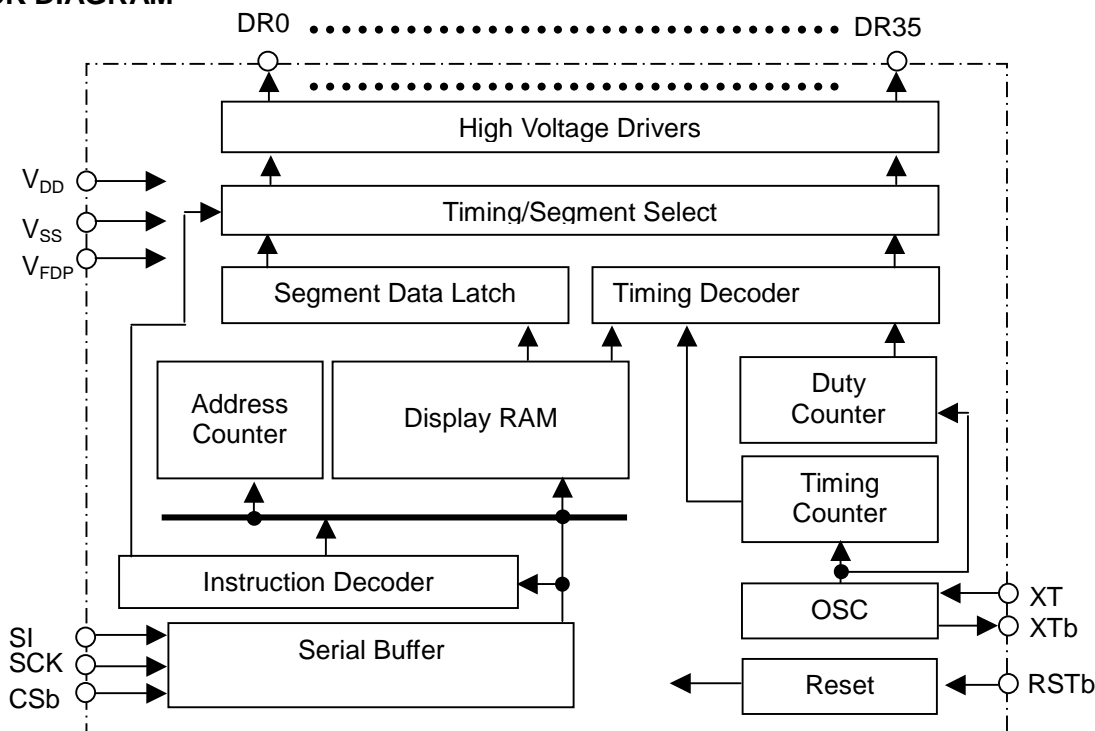

■ PIN CONFIGURATION

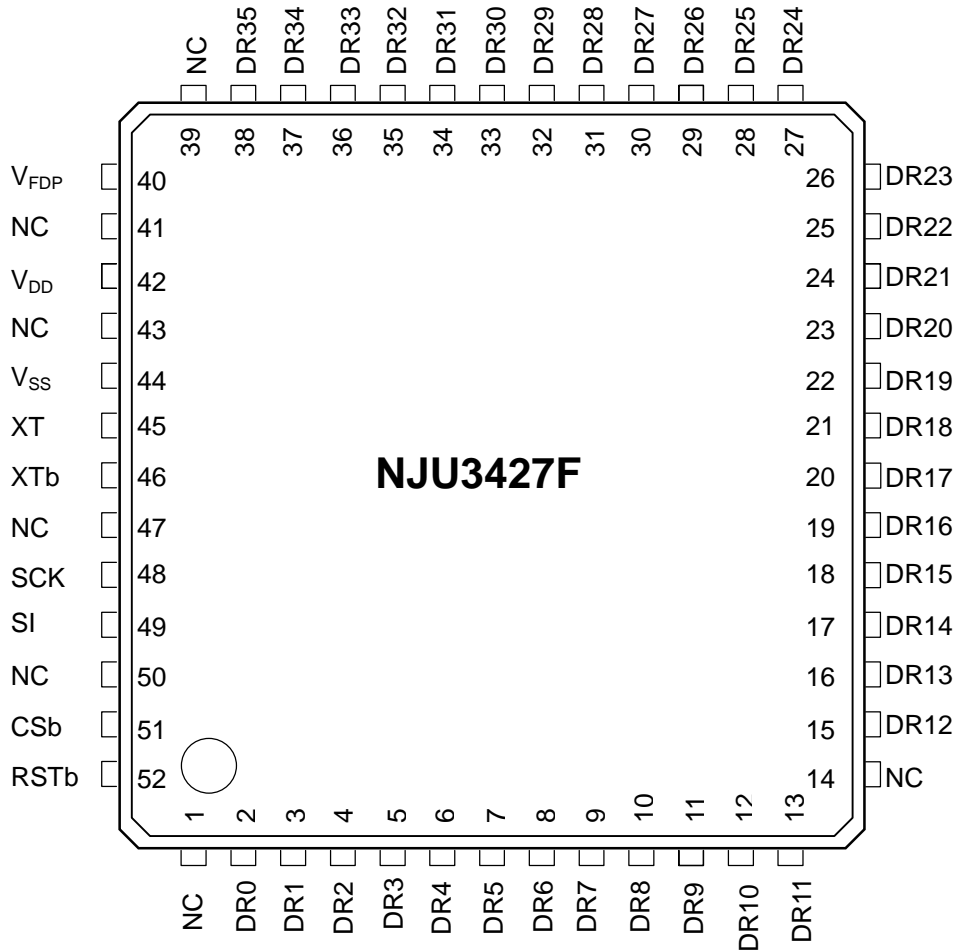

■ PIN DESCRIPTION

No.	Symbol	Function
42	V <sub>DD</sub>	Logic power supply 3.0V / 5.0V
44	V <sub>SS</sub>	GND V <sub>SS</sub> =0V
40	V <sub>FDP</sub>	Power supply for VFD driving
2 ~ 13, 15 ~ 38	DR0~ DR35	Driving signal output The configure of the Segment and Timing drivers is determined by the instruction, refer to (2) Instruction Register.
52	RSTb	Reset If RSTb="L", reset occurs, but data on DDRAM not changing.
51	CSb	Chip select If CSb="L", data transmission is enabled.
48	SCK	Serial clock
49	SI	Serial data input (8-bit/one word)
45, 46	XT, XTb	Connecting external capacitor and resistor, or input clock via this pin If using external clock, input clock signal via XT and keep XTb open.
1, 14, 39, 41, 43, 47, 50	NC	No connect Usually open.

## ■ FUNCTION DESCRIPTION

### (1) Address Counter

The address counter specifies the RAM address, and the display data from CPU is written to the specified address.

If the upper 2 bits (B7, B6) of the 1<sup>st</sup> word are “0,0”, the rest 6 bits (B5~B0) will be interpreted as RAM address. The 2<sup>nd</sup> word will be interpreted as display data and saved on the RAM which address is specified by the B5~B0 of the 1<sup>st</sup> data.

Once the RAM address is determined by the 1<sup>st</sup> data, the address counter will automatically increase (+1) for every following word. So there is no need to specify the address for every word for a consecutive data transfer.

During display data writing, even there is unused or not-existing RAM area, be sure to input 8-bit serial data. The data allocated to the above mentioned area is invalid.

The RAM address range varies with programmable duty ratios. For 1/4 duty, the address range is from “00H~0FH”. For 1/8 duty, the range is from “00H~1FH”. For 1/12 duty, the range is from “00H~23H”. For 1/16 duty, the range is from “00H~2FH”. When automatically increased address excess the address range and display data is still transferred from CPU, the address counter will return to “00H” and count up again.

Address Data

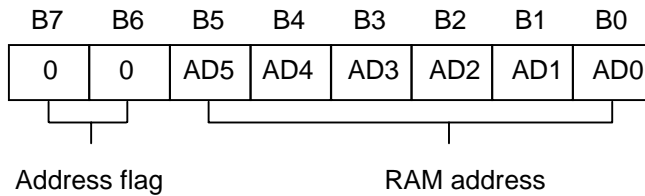





**(2) Instruction Register 1**

The Instruction Register 1 is used for setting duty ratio and driver (DR) pins configure. If B7 of the 1<sup>st</sup> word is “1”, the rest 4 bits (B5, B4, B1, B0) is interpreted as instruction 1.

The value on register is initialized to the default by reset signal. But, during power on, the value of register 1 is unspecified, it is necessary to set value in register 1.

The contents of the “Instruction register 1” is initially set up by reset signal, as shown below. Because the NJU3427 is unstable during power on, reset shall be executed.

Instruction Register 1 Default

Duty ratio 1/16

DR pins pattern 1

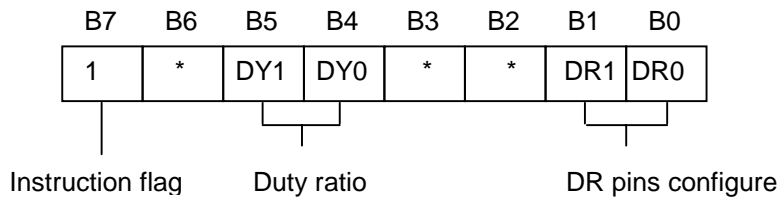

DY1	DY0	Duty Ratio
0	0	1/16
0	1	1/12
1	0	1/8
1	1	1/4

Note): For Segment and Timing pins configure, please refer to “The Relationship Between Duty Ratio and Segment/Timing Pins”. When select 1/4 and 1/8 duty, configures of segment and timing pins are the same.

DR1	DR0	DR configure
0	0	Pattern 1
0	1	Pattern 2
1	0	Pattern 3
1	1	Pattern 4

Note): For Segment and Timing pins configure, please refer to “The relationship Between Duty Ratio and Segment/Timing Pins”.

## The Relationship Between Duty Ratio and Segment (S)/Timing (T) Pins Configure

- Pattern 1

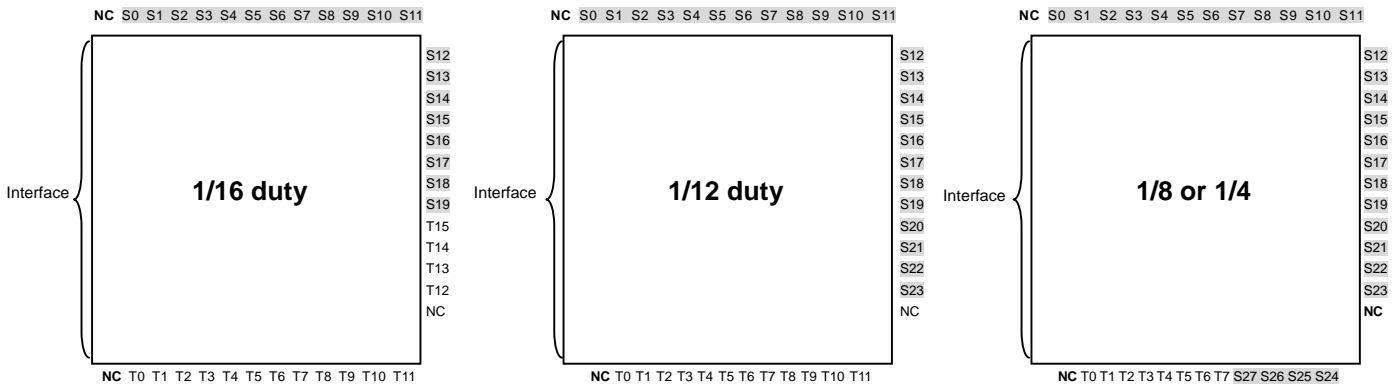

- Pattern 2

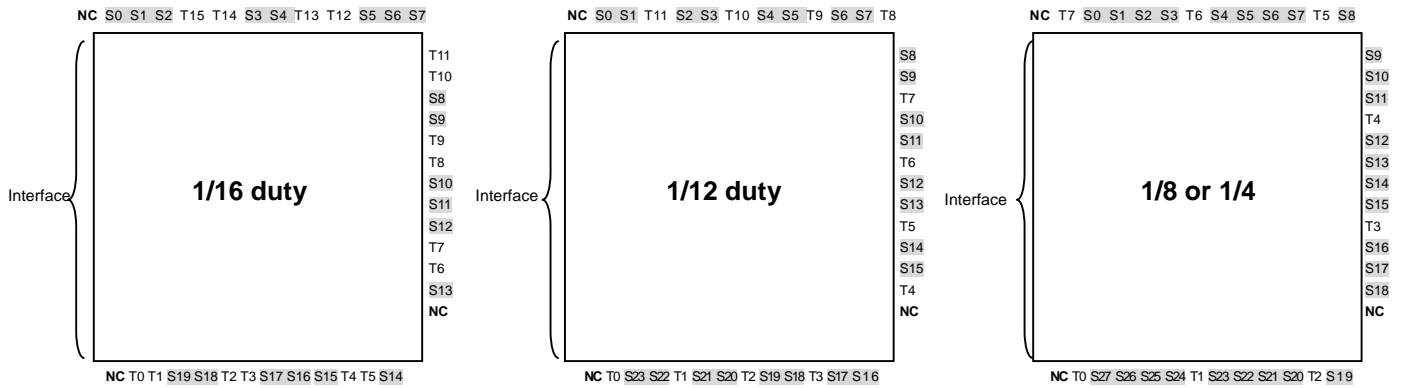

- Pattern 3

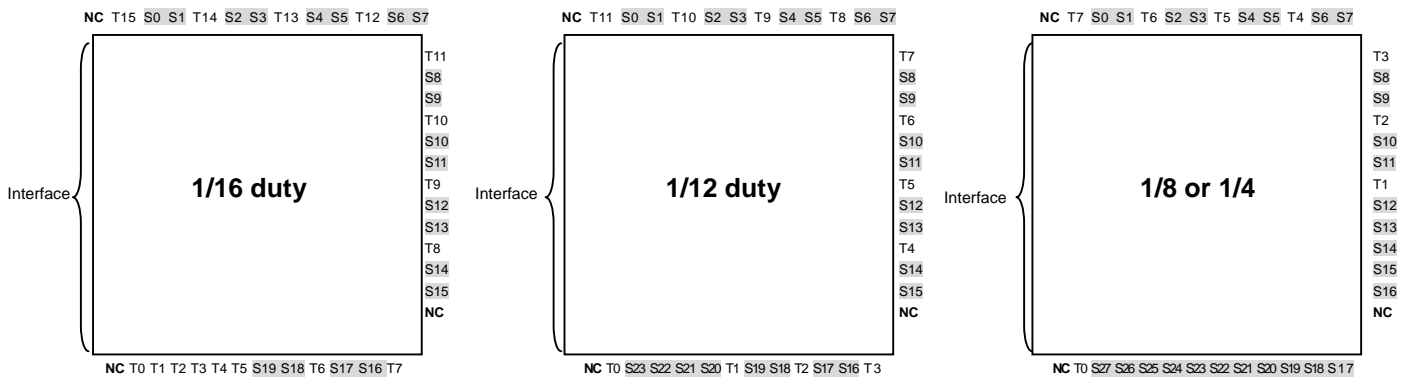

- Pattern 4

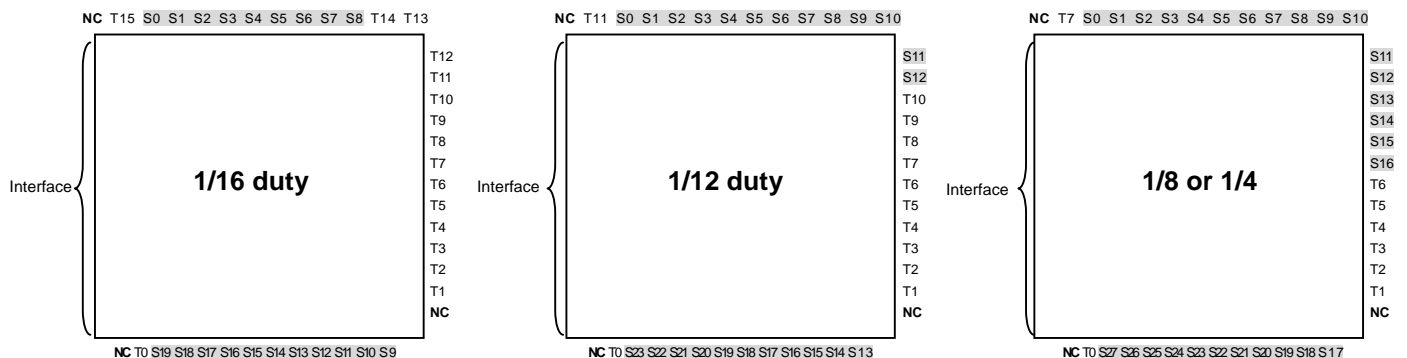

**(3) Instruction Register 2**

The Instruction Register 2 is used for setting Timing signal duty ratio and controlling display ON/OFF. If B7 and B6 of the 1<sup>st</sup> word are “0, 1”, the rest 4 bits (B4~B1) is interpreted as instruction 2.

When power on or reset signal input, the Register 2 is initialized as below: Because the NJU3427 is unstable during power on, reset shall be executed.

Instruction Register 2 Default

Timing duty ratio                    2/16  
 Display ON/OFF                    OFF

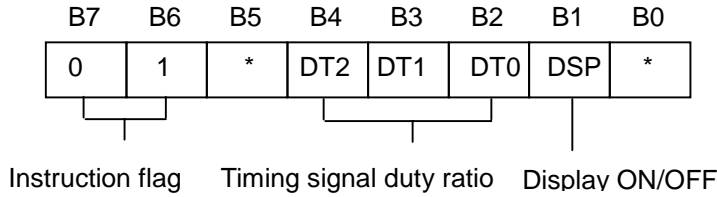

DT2	DT1	DT0	Timing duty ratio
0	0	0	2/16
0	0	1	4/16
0	1	0	6/16
0	1	1	8/16
1	0	0	10/16
1	0	1	12/16
1	1	0	14/16
1	1	1	15/16

Note): For the output waveform, refer to “Timing Signal Duty Ratio”.

DSP	Display control
0	OFF
1	ON

Note): During display off, there is no signal from Timing pins and Segment pins.



● Timing Signal and Duty Ratio

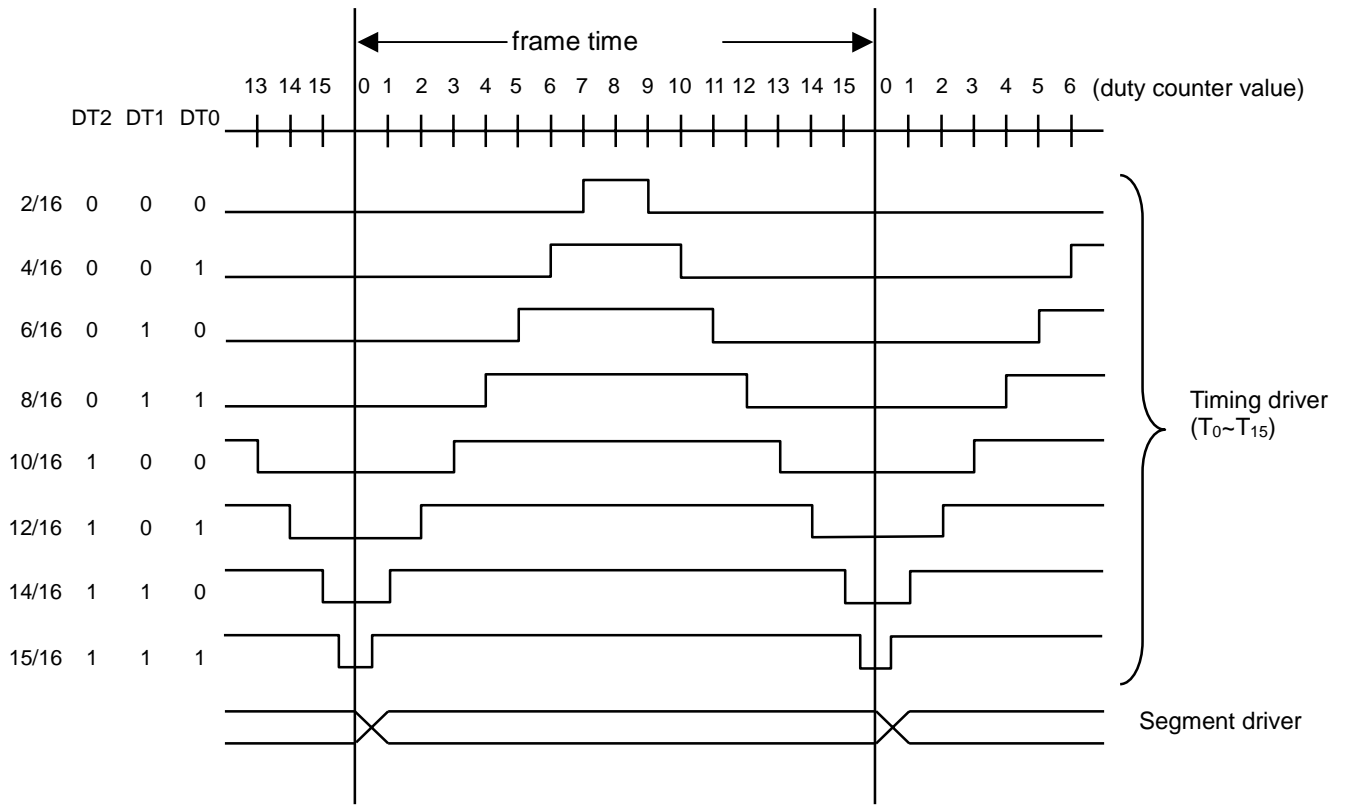

● Display Timing Charter

- Duty ratio 1/16

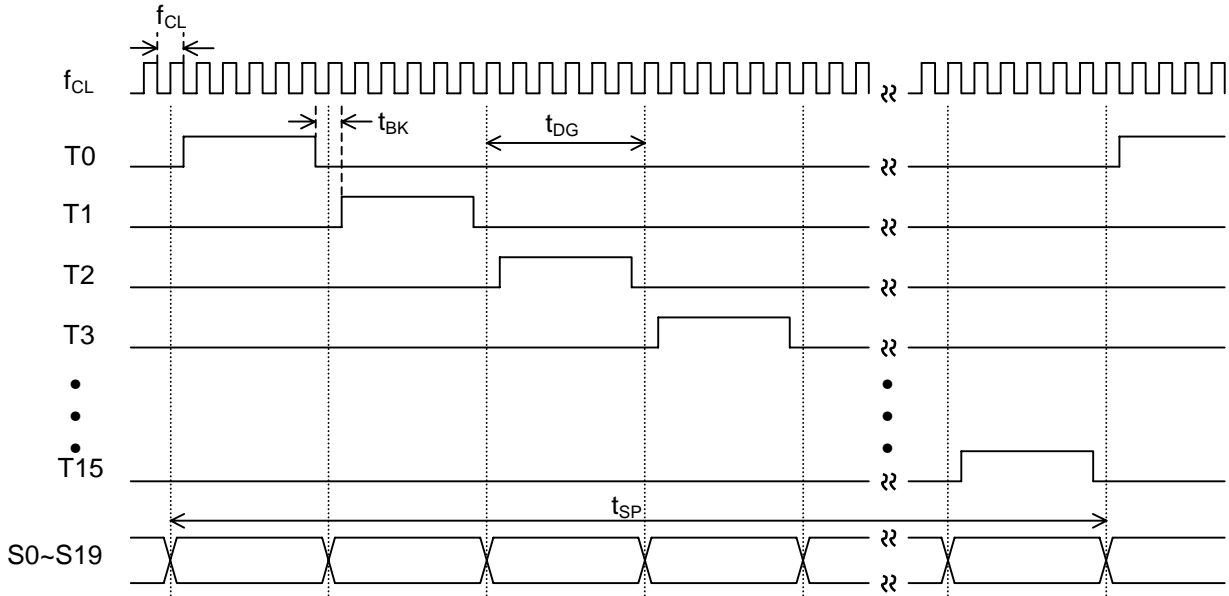

External Clock Frequency	800kHz~2.5MHz	$f_{CL}$
Minimum Blinking Time (Timing Signal Duty Ratio = 15/16)	40 $\mu$ s~12.8 $\mu$ s	$t_{BK}=(1/f_{CL}) \times 16 \times 2$
1-character display time	640 $\mu$ s ~204.8 $\mu$ s	$t_{DG}=t_{BK} \times 16$
Frame time	10.24ms~3.2768ms	$t_{SP}=t_{DG} \times 16$

- Duty ratio 1/12

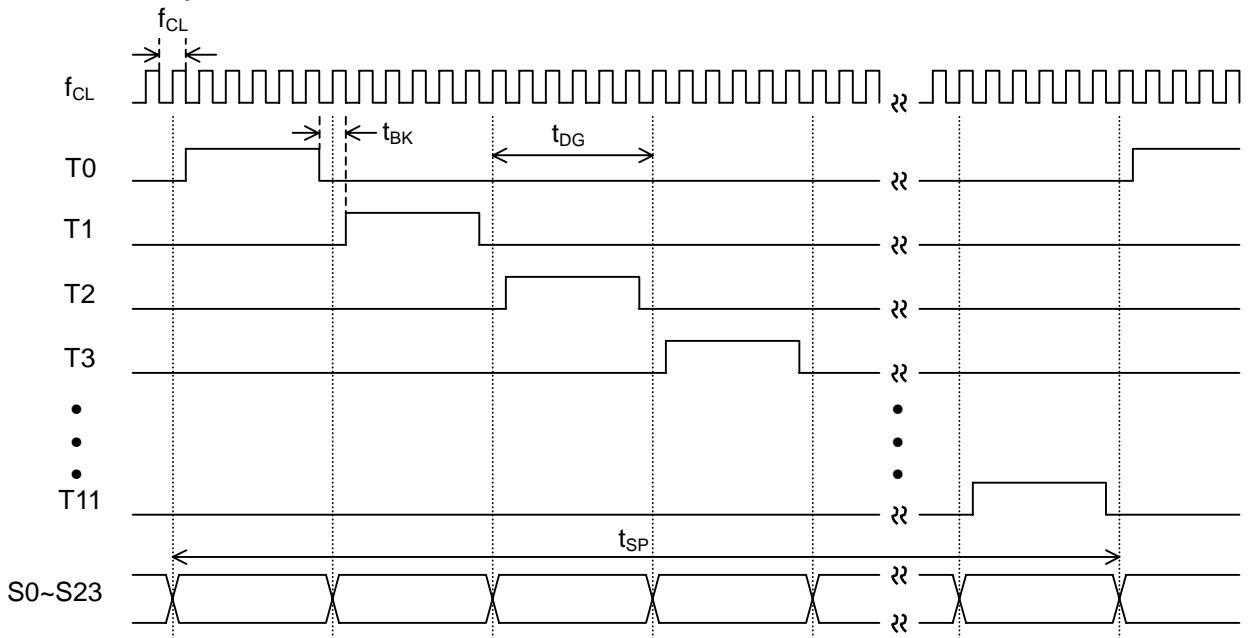

External Clock Frequency	800kHz~2.5MHz	$f_{CL}$
Minimum Blinking Time (Timing Signal Duty Ratio = 15/16)	55 $\mu$ s~17.6 $\mu$ s	$t_{BK}=(1/f_{CL}) \times 22 \times 2$
1-character display time	880 $\mu$ s ~281.6 $\mu$ s	$t_{DG}=t_{BK} \times 16$
Frame time	10.56ms~3.3792ms	$t_{SP}=t_{DG} \times 12$

- Duty Ratio 1/8

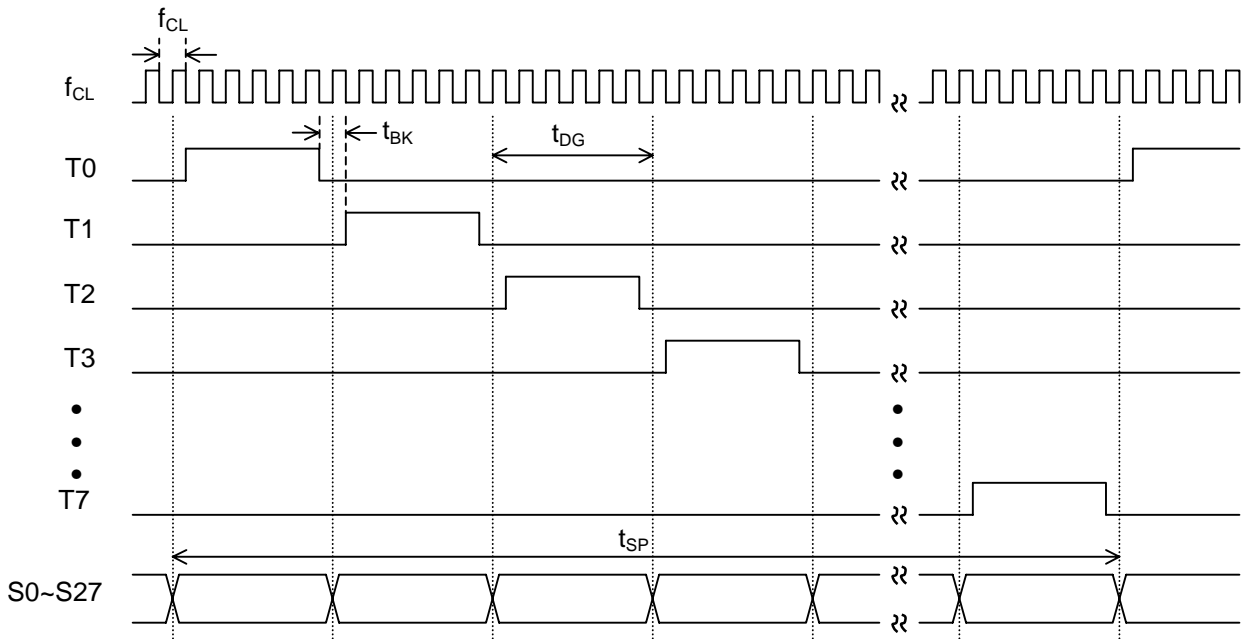

External Clock Frequency	800kHz~2.5MHz	( $f_{CL}$ )
Minimum Blanking Time (Timing Signal Duty Ratio = 15/16)	80 $\mu$ s~25.6 $\mu$ s	$t_{BK}=(1/f_{CL}) \times 32 \times 2$
1-character display time	1.28ms~409.6 $\mu$ s	$t_{DG}=t_{BK} \times 10$
Frame time	10.24ms~3.2768ms	$t_{SP}=t_{DG} \times 8$

- Duty ratio 1/4 (T4~T7 output pins)

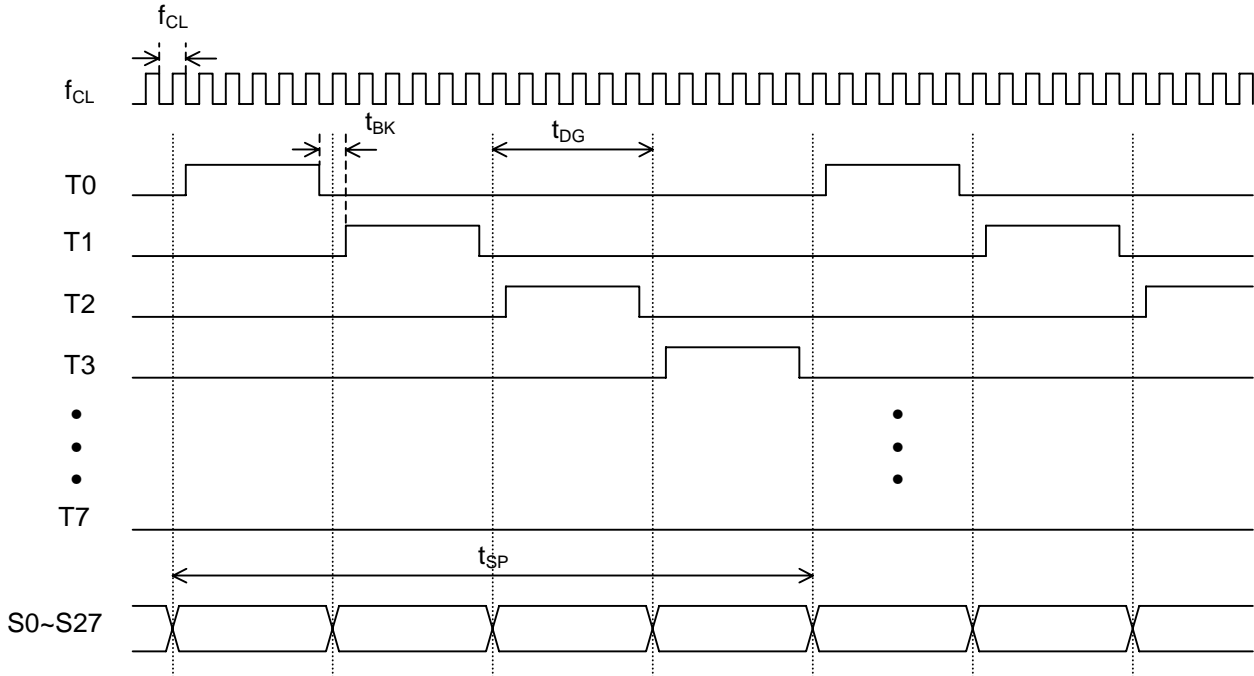

External Clock Frequency	800kHz~2.5MHz	( $f_{CL}$ )
Minimum Blanking Time (Timing Signal Duty Ratio = 15/16)	160 $\mu$ s~51.2 $\mu$ s	$t_{BK}=(1/f_{CL}) \times 64 \times 2$
1-character display time	2.56ms~819.2 $\mu$ s	$t_{DG}=t_{BK} \times 16$
Frame time	10.24ms~3.2768ms	$t_{SP}=t_{DG} \times 4$

**(4) Serial Interface**

8-bit per word serial data is transferred from CPU to NJU3427 with synchronous clock signal (SCK). At the every rising edge of the SCK, data is taken in, and at the rising edge of CSb, the data of words are latched.

If the 1<sup>st</sup> data is address data when CSb becoming “L”, without changing CSb, the following data will be interpreted as display data. If the 1<sup>st</sup> data is instruction, without changing CSb signal, all the following data is invalid.

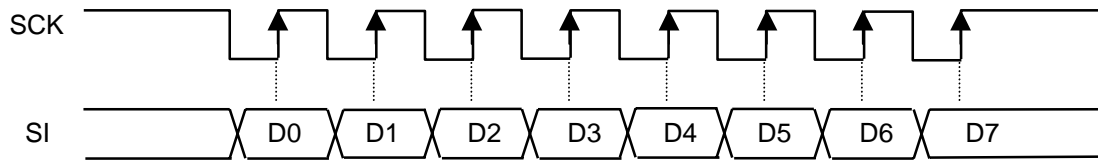

Serial data transmission

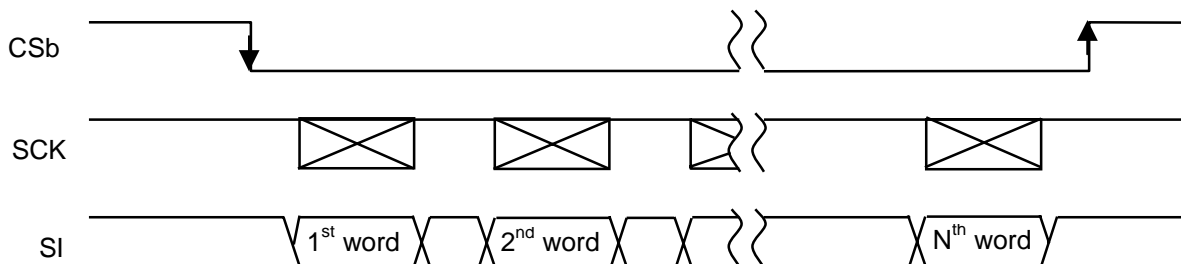

Serial data transmission format

- Serial Data
- 1<sup>st</sup> word

**Address data**

B7	B6	B5	B4	B3	B2	B1	B0
0	0	AD5	AD4	AD3	AD2	AD1	AD0

**Instruction 1**

B7	B6	B5	B4	B3	B2	B1	B0
1	*	DY1	DY0	*	*	DR1	DR0

\*:don't care

**Instruction 2**

B7	B6	B5	B4	B3	B2	B1	B0
0	1	*	DT2	DT1	DT0	DSP	*

\*:don't care

From the 2<sup>nd</sup> word

- If the 1<sup>st</sup> word is address data      display data
- If the 1<sup>st</sup> word is instruction data    invalid data

**(5) Reset Circuit**

If RSTb="L", reset circuit functions, and the following default is set up. Because the NJU3427 is unstable during power on, reset shall be executed.

Address Data

(AD0, AD1, AD2, AD3, AD4, AD5): (0, 0, 0, 0, 0, 0)

Instruction Register 1

Duty ratio                    1/16

DR pins configure                    Pattern 1

Instruction Register 2

Timing signal duty ratio                    2/16

Display ON/OFF                    OFF

## ■ ABSOLUTE MAXIMUM RATINGS

Parameter	Symbol	Rating	Unit	Conditions
Power Supply	$V_{DD}$	-0.3~+7.0	V	
Input Voltage	$V_{IN}$	-0.3~ $V_{DD}+0.3$	V	
VFD Driving Voltage	$V_{FDP}$	$V_{DD}-45\sim V_{DD}+0.3$	V	$V_{DD}$ as reference voltage
H Level Output Current 1	$I_{OH1}$	-35	mA	DR <sub>0</sub> output, signal pin
H Level Output Current 2	$I_{OH2}$	-15	mA	DR <sub>1</sub> ~ DR <sub>35</sub> output, signal pin
L Level Output Current	$I_{OL}$	20	mA	
Operating Temperature	Topr	-40 ~ 85	°C	
Storage Temperature	Tstg	-55 ~ 125	°C	
Power Dissipation	PD	900(QFP52-A2) 1200(QFP52-H2)	mW	Glass epoxy board (76.2 x114.3x1.6mm)

Note 1): The IC must be used within the Absolute Maximum Ratings, otherwise, an electrical or physical stress may cause a permanent damage to it.

Note 2): De-coupling capacitors should be placed between  $V_{DD}-V_{SS}$  and  $V_{FDP}-V_{SS}$ .

Note 3): The condition of  $V_{DD} > V_{SS} \geq V_{FDP}$  and  $V_{SS}=0$  must be maintained.

■ ELECTRICAL CHARACTERISTICS

DC Characteristics 1

( $V_{DD}=5.0V, V_{SS}=0V, T_a=-40 \sim 85^{\circ}C$ )

Parameter	Symbol	Conditions	MIN	TYP	MAX	Unit	
Power Supply (1)	$V_{DD}$	$V_{DD}$ pin	4.5	-	5.5	V	
Power Supply (2)	$V_{FDP}$	$V_{FDP}$ pin and $V_{DD}$ as reference	-40	-	$V_{SS}$	V	
H Level Input Voltage	$V_{IH}$	XT, RSTb, CSb, SCK, SI pins	$0.8V_{DD}$	-	-	V	
L Level Input Voltage	$V_{IL}$		-	-	$0.2V_{DD}$		
Input off-leak current	$I_{IZ}$	CSb, SCK, SI pins $V_{DD}=5.5V, V_I=0$ or $5.5V$	-	-	$\pm 1$	$\mu A$	
Display Current	$I_{OH}$	$DR_0$ pin	$V_{DD}=4.5V, V_{FDP}=V_{DD}-40$	-11.5	-20	-	mA
		$DR_1 \sim DR_{35}$ pin	$V, V_{OH}=V_{DD}-2.25V$	-5.5	-10	-	mA
Pull-up Resistance	$R_{UR}$	RSTb pin, $T_a=25^{\circ}C, V_I=V_{SS}$	100	-	300	k $\Omega$	
Pull-down Resistance	$R_{DST}$	$DR_0 \sim DR_{35}$ pins, $T_a=25^{\circ}C$ $V_I=V_{DD}, V_{FDP}=V_{DD}-40V$	75	-	195	k $\Omega$	
Logic Circuit Power Supply	$I_{SS}$	$V_{SS}$ pin CR oscillation ( $R=6.8k\Omega, C=100pF$ ), All Segment/Timing pins open, RSTb open All Segment/Timing pins output display OFF signal.	-	0.6	0.8	mA	
Operation Current	$I_{FDP}$	$V_{FDP}$ pin, $V_{FDP}=V_{DD}-40V$ , CR oscillation ( $R=6.8k\Omega, C=100pF$ ), All driving pins output display ON signal	-	12	16.5	mA	
CR Oscillation Frequency	$f_{CR}$	$T_a=25^{\circ}C$ $R=6.8k\Omega, C=100pF$	1.05	1.13	1.21	MHz	

• AC Characteristics 1

( $V_{DD}=5.0V, V_{SS}=0V, T_a=-40 \sim 85^{\circ}C$ )

Parameter	Symbol	Conditions	MIN	TYP	MAX	Unit
External Clock Frequency	$f_{CL}$	Fig 1	0.8	-	2.5	MHz
Width of External Clock Pulse	$t_{CLH}, t_{CLL}$	Fig 1	200			ns
Data Setup Time	$t_{SIS}$	Fig2	35			ns
Data Hold Time	$t_{SIH}$	Fig2	35			ns
Clock Frequency	$f_{SCK}$	Fig3			2.0	MHz
Clock Pulse Width	$t_{SCKH}, t_{SCKL}$	Fig3	200			ns
External Clock Rising Time, Falling Time	$t_{CLH}, t_{CLL}$	Fig2			250	ns
Clock Interval Time	$t_{SCI}$	Fig3	10			$\mu s$
Reset Pulse Width	$t_{RSTb}$	Fig4	10			$\mu s$

• DC Characteristics 2

(V<sub>DD</sub>=3.0V, V<sub>SS</sub>=0V, T<sub>a</sub>=-40 ~ 85°C)

Parameter	Symbol	Conditions	MIN	TYP	MAX	Unit
Power Supply (1)	V <sub>DD</sub>	V <sub>DD</sub> pin	2.7	-	3.6	V
Power Supply (2)	V <sub>FDP</sub>	V <sub>FDP</sub> pin and V <sub>DD</sub> as reference	-40	-	V <sub>SS</sub>	V
H Level Input Voltage	V <sub>IH</sub>	XT, RSTb, CSb, SCK, SI pins	0.8V <sub>DD</sub>	-	-	V
L Level Input Voltage	V <sub>IL</sub>		-	-	0.2V <sub>DD</sub>	
Input off-leak current	I <sub>IZ</sub>	CSb, SCK, SI pins V <sub>DD</sub> =3.6V, V <sub>I</sub> =0 or 3.6V	-	-	±1	μA
Display Current	I <sub>OH</sub>	DR <sub>0</sub> pin	-5.0	-9.0	-	mA
		DR <sub>1</sub> ~ DR <sub>35</sub> pin	-2.5	-4.0	-	mA
Pull-up Resistance	R <sub>UR</sub>	RSTb pin, T <sub>a</sub> =25°C, V <sub>I</sub> =V <sub>SS</sub>	100	-	300	kΩ
Pull-down Resistance	R <sub>DST</sub>	DR <sub>0</sub> ~ DR <sub>35</sub> pins, T <sub>a</sub> =25°C V <sub>I</sub> =V <sub>DD</sub> , V <sub>FDP</sub> =V <sub>DD</sub> -40V	75	-	195	kΩ
Logic Circuit Power Supply	I <sub>SS</sub>	V <sub>SS</sub> pin CR oscillation (R=4.7kΩ, C=100pF), All Segment/Timing pins open, RSTb open All Segment/Timing pins output display OFF signal.	-	0.25	0.35	mA
Operation Current	I <sub>FDP</sub>	V <sub>FDP</sub> pin, V <sub>FDP</sub> =V <sub>DD</sub> -40V, CR oscillation (R=4.7kΩ, C=100pF), All driving pins output display ON signal	-	12	16.5	mA
CR Oscillation Frequency	f <sub>CR</sub>	T <sub>a</sub> =25°C R=4.7kΩ, C=100pF	1.05	1.13	1.21	MHz

• AC Characteristics 2

(V<sub>DD</sub>=3.0V, V<sub>SS</sub>=0V, T<sub>a</sub>=-40 ~ 85°C)

Parameter	Symbol	Conditions	MIN	TYP	MAX	Unit
External Clock Frequency	f <sub>CL</sub>	Fig 1	0.8	-	2.5	MHz
Width of External Clock Pulse	t <sub>CLH</sub> , t <sub>CLL</sub>	Fig 1	200			ns
Data Setup Time	t <sub>SIS</sub>	Fig2	35			ns
Data Hold Time	t <sub>SIH</sub>	Fig2	35			ns
Clock Frequency	f <sub>SCK</sub>	Fig3			2.0	MHz
Clock Pulse Width	t <sub>SCKH</sub> , t <sub>SCKL</sub>	Fig3	200			ns
External Clock Rising Time, Falling Time	t <sub>CLH</sub> , t <sub>CLL</sub>	Fig2			250	ns
Clock Interval Time	t <sub>SCI</sub>	Fig3	10			μs
Reset Pulse Width	t <sub>RSTb</sub>	Fig4	10			μs



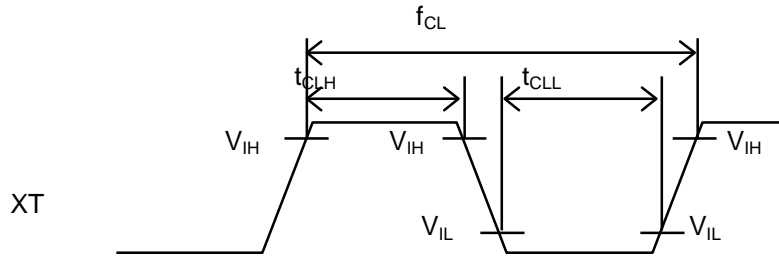

Fig1

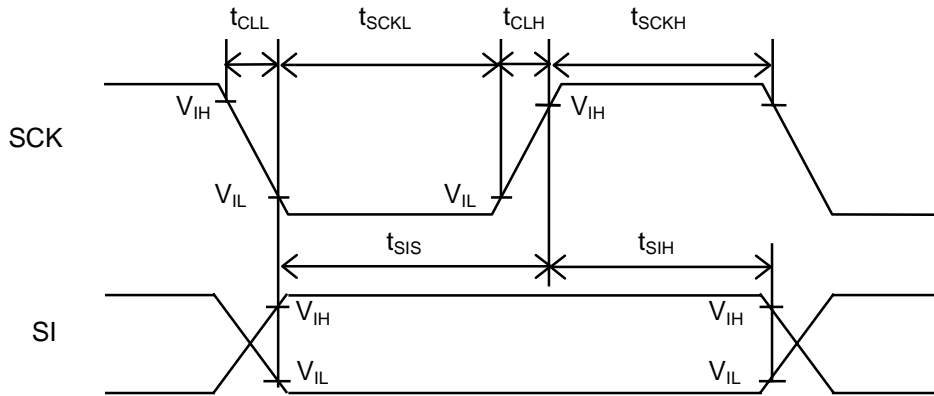

Fig2

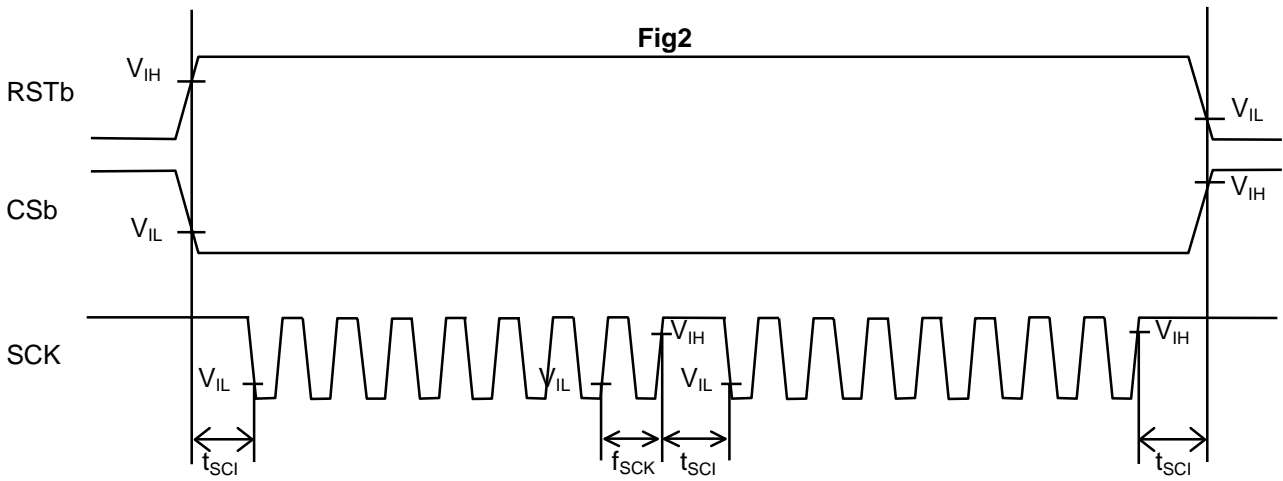

Fig3

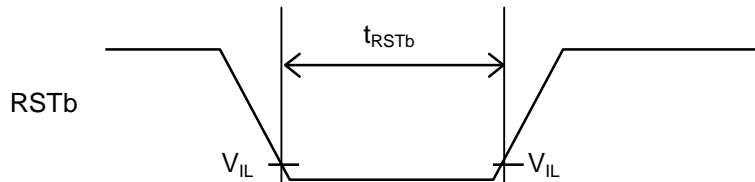
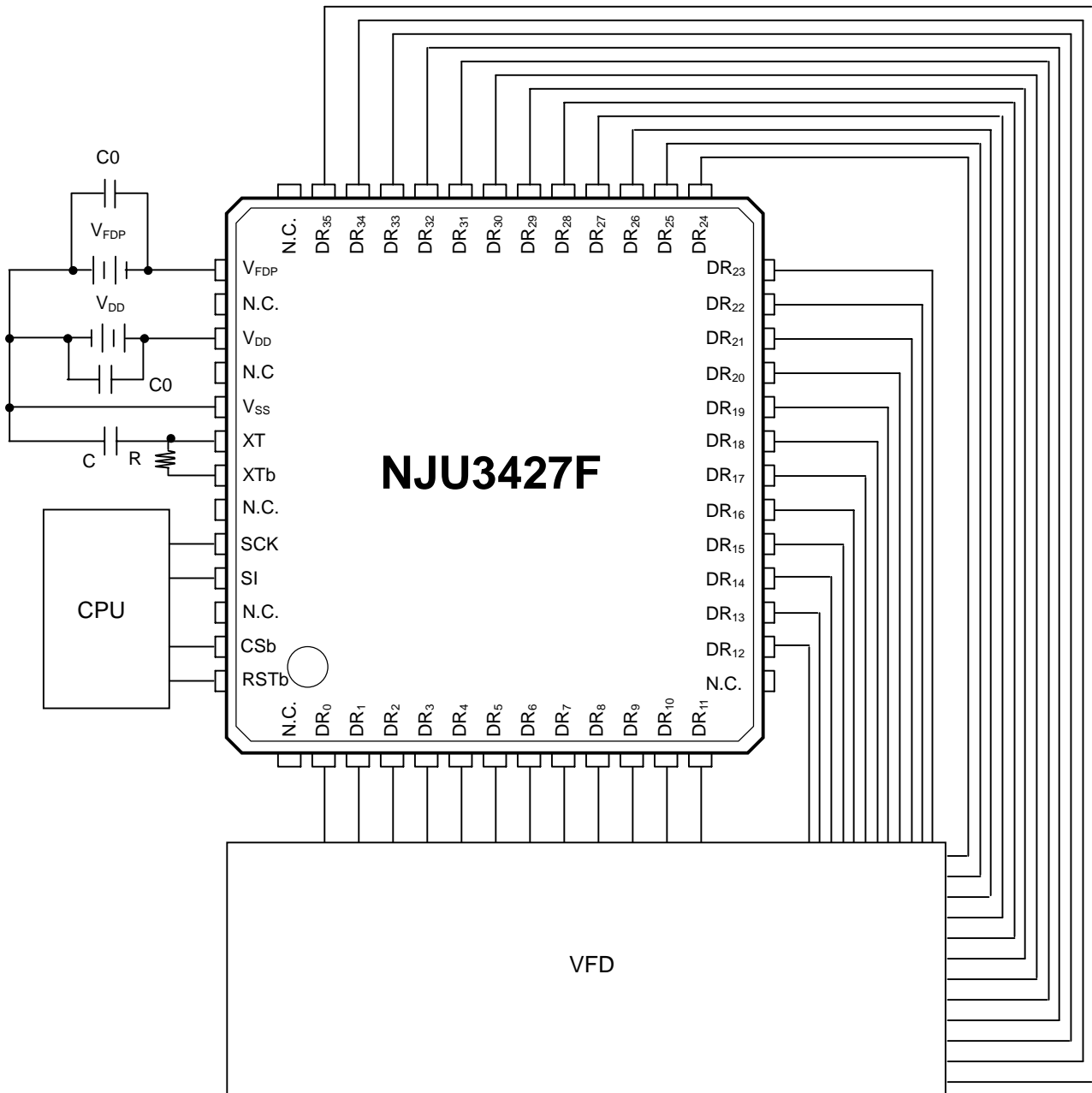

Fig4

■ APPLICATION CIRCUIT (CR OSCILLATION)



\* Pay careful attention to reduce the noise from power supply and interface pins.

[CAUTION]  
 The specifications on this databook are only given for information, without any guarantee as regards either mistakes or omissions. The application circuits in this databook are described only to show representative usages of the product and not intended for the guarantee or permission of any right including the industrial rights.

# Mouser Electronics

Authorized Distributor

Click to View Pricing, Inventory, Delivery & Lifecycle Information:

[NJR:](#)

[NJU3427FA2](#)

Компания «Океан Электроники» предлагает заключение долгосрочных отношений при поставках импортных электронных компонентов на взаимовыгодных условиях!

Наши преимущества:

- Поставка оригинальных импортных электронных компонентов напрямую с производств Америки, Европы и Азии, а так же с крупнейших складов мира;
- Широкая линейка поставок активных и пассивных импортных электронных компонентов (более 30 млн. наименований);
- Поставка сложных, дефицитных, либо снятых с производства позиций;
- Оперативные сроки поставки под заказ (от 5 рабочих дней);
- Экспресс доставка в любую точку России;
- Помощь Конструкторского Отдела и консультации квалифицированных инженеров;
- Техническая поддержка проекта, помощь в подборе аналогов, поставка прототипов;
- Поставка электронных компонентов под контролем ВП;
- Система менеджмента качества сертифицирована по Международному стандарту ISO 9001;
- При необходимости вся продукция военного и аэрокосмического назначения проходит испытания и сертификацию в лаборатории (по согласованию с заказчиком);
- Поставка специализированных компонентов военного и аэрокосмического уровня качества (Xilinx, Altera, Analog Devices, Intersil, Interpoint, Microsemi, Actel, Aeroflex, Peregrine, VPT, Syfer, Eurofarad, Texas Instruments, MS Kennedy, Miteq, Cobham, E2V, MA-COM, Hittite, Mini-Circuits, General Dynamics и др.);

Компания «Океан Электроники» является официальным дистрибьютором и эксклюзивным представителем в России одного из крупнейших производителей разъемов военного и аэрокосмического назначения «JONHON», а так же официальным дистрибьютором и эксклюзивным представителем в России производителя высокотехнологичных и надежных решений для передачи СВЧ сигналов «FORSTAR».



## JONHON

«JONHON» (основан в 1970 г.)

Разъемы специального, военного и аэрокосмического назначения:

(Применяются в военной, авиационной, аэрокосмической, морской, железнодорожной, горно- и нефтедобывающей отраслях промышленности)

«FORSTAR» (основан в 1998 г.)

ВЧ соединители, коаксиальные кабели, кабельные сборки и микроволновые компоненты:

(Применяются в телекоммуникациях гражданского и специального назначения, в средствах связи, РЛС, а так же военной, авиационной и аэрокосмической отраслях промышленности).



Телефон: 8 (812) 309-75-97 (многоканальный)

Факс: 8 (812) 320-03-32

Электронная почта: [ocean@oceanchips.ru](mailto:ocean@oceanchips.ru)

Web: <http://oceanchips.ru/>

Адрес: 198099, г. Санкт-Петербург, ул. Калинина, д. 2, корп. 4, лит. А