

ZONE	REV	SCR NUMBER	DESCRIPTION	BY	DATE	APPROVED
ALL	A	DSMH-8X6RDF.VER01	NEW RELEASE	HCL-AS	08/16/2012	D.SMITH
	B	BRID-93SUS6.VER01	TABLE 1 ADDED FOR WITH STSG OPTION REMOVED LEADED PLATING OPTIONS	HCL-AP	01/11/2013	B.RICHARD
	C	JXUU-98N7HA.VER01	ADDED CORING	HCL-AK	07/02/2013	J.XU

**TABLE 1**  
COMPLIANT PIN, 0.0177" DRILL, 100 Ω WITH STSG, WITHOUT CAPS

PART NUMBER	REV	MAKE FROM		FINISH ⑫	DESCRIPTION
		SIGNAL LF A	SHIELD IM-A		
154-4411-10D	C	160-0808-769	154-4311-10D	769 PER EGS 205	PREPPED
154-4411-10E	C	160-0808-768	154-4311-10E	768 PER EGS 205	
154-4411-10H	C	160-0808-806	154-4311-10H	806 PER EGS 205	
154-4411-10J	C	160-0808-805	154-4311-10J	805 PER EGS 205	
154-4511-10X	C	154-4411-10X		⑫	OVERMOLD
154-4611-10X	C	154-4511-10X		⑫	LOOSE PIECE

**TABLE 2**  
COMPLIANT PIN, 0.0177" DRILL, 100 Ω WITHOUT STSG, WITHOUT CAPS

PART NUMBER	REV	MAKE FROM		FINISH ⑫	DESCRIPTION
		SIGNAL LF A	SHIELD IM-A		
154-4421-10D	C	160-0808-769	154-4321-10D	769 PER EGS 205	PREPPED
154-4421-10E	C	160-0808-768	154-4321-10E	768 PER EGS 205	
154-4421-10H	C	160-0808-806	154-4321-10H	806 PER EGS 205	
154-4421-10J	C	160-0808-805	154-4321-10J	805 PER EGS 205	
154-4521-10X	C	154-4421-10X		⑫	OVERMOLD
154-4621-10X	C	154-4521-10X		⑫	LOOSE PIECE

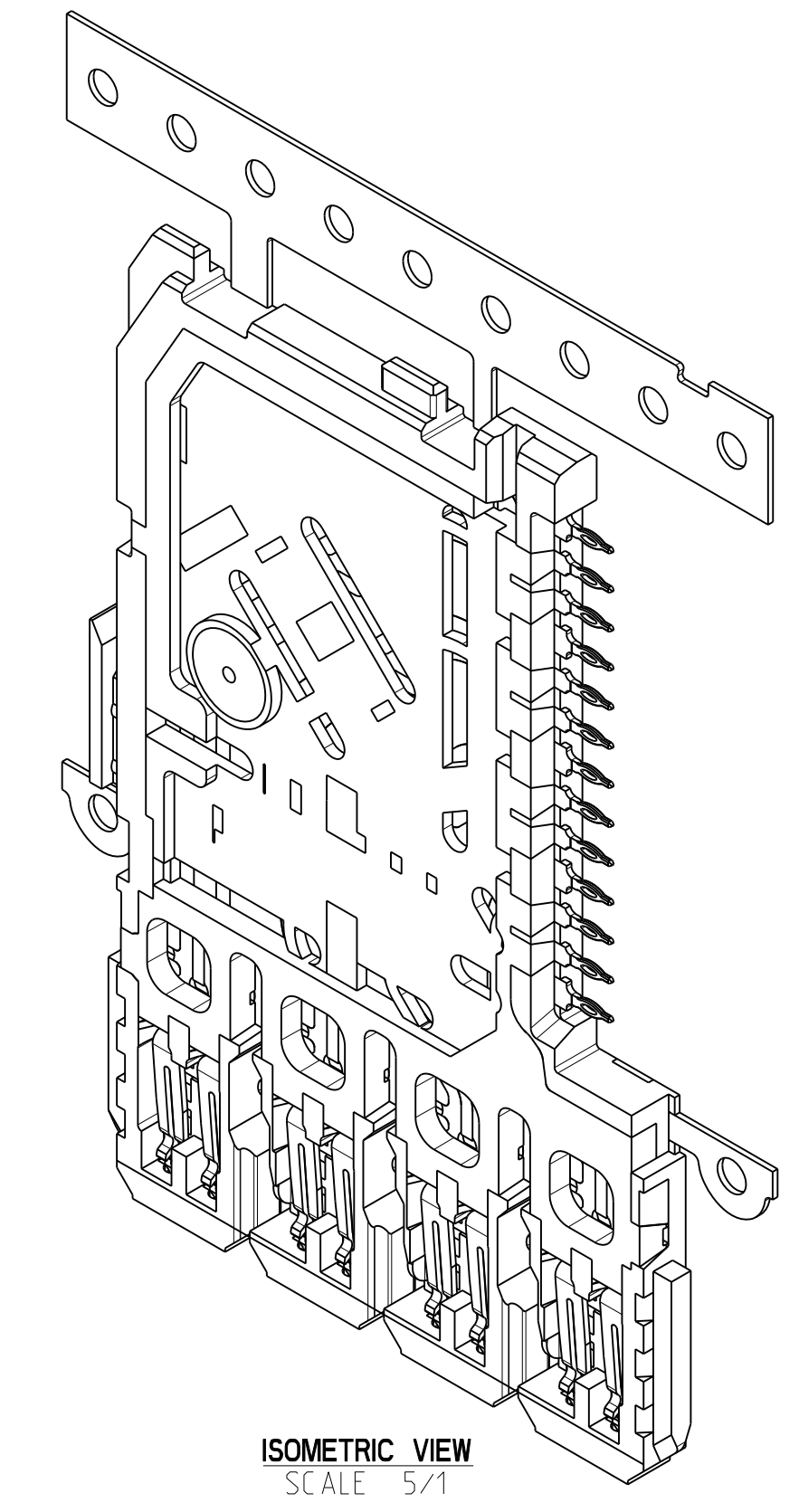

NOTES:

- ① MATERIAL: 807-0000-070 PER EGS 207.
- ② 0.2 MAX FLASH UNLESS OTHERWISE SPECIFIED.
3. PARTS ARE TO BE IN ACCORDANCE WITH EGPS 0201.
- ④ PARTS TO BE SUPPLIED ON REELS ON 26.00 CENTERS AS SHOWN.
5. SOME DIMENSIONS TO BE CONTROLLED BY SPC. SPC DATA WILL BE SUBMITTED WITH EVERY LOT. SEE SHEET 5 FOR FPIR.
6. MANUFACTURER SHALL NOTIFY AMPHENOL TCS IN WRITING 30 DAYS PRIOR TO CHANGES IN MANUFACTURING LOCATION, MATERIALS, DESIGN, OR MANUFACTURING PROCESS. WRITTEN ACCEPTANCE MUST BE RECEIVED PRIOR TO IMPLEMENTATION OF CHANGE. THIS DOES NOT REQUIRE THE MANUFACTURER TO REVEAL ANY PROPRIETARY INFORMATION.
7. FINISHED MOLDED PART SHALL RETAIN ALL TOLERANCE REQUIREMENTS OF STAMPED PART (160-0808-XXX) AS SPECIFIED ON DRAWING 160-0808-500 AND INSERT MOLDED PART (154-4321-XXX) AS SPECIFIED ON DRAWING 154-4321-500.
8. CHANGES IN THIS DRAWING MAY AFFECT PART NUMBER 160-0808-XXX, REFERENCE DRAWING 160-0808-500 AND PART NUMBER 154-4321-XXX, REFERENCE DRAWING 154-4321-500
- ⑨ SEE FLASH MAP FOR CRITICAL FLASH AREAS & REQUIREMENTS.
10. METALIC SLIVERS OR SPECKS ON FINISHED PRODUCT OR MOLDED IN PLASTIC ARE NOT ACCEPTABLE.
- ⑪ GATE LOCATION APPROXIMATELY WHERE SHOWN. 1 GATE PER PART. GATE TO BE RECESSED SUFFICIENTLY SO VESTIGE WILL NOT EXCEED TOP SURFACE.
- ⑫ CAVITY I.D. RECESS AREA TO BE LOCATED APPROXIMATELY WHERE SHOWN. CHARACTERS TO BE 0.80 TALL.
13. MAX ALLOWABLE SINK 0.15 MAX.
14. PART TO BE FREE OF BURRS IN EXCESS OF 0.05 MAX. UNLESS OTHERWISE SPECIFIED.
15. CRITICAL AREA BURRS NOT TO EXCEED 0.025 MAX.
16. PLATING TO BE IN ACCORDANCE WITH QAPS 0425.
17. STAMPING TO BE IN ACCORDANCE WITH QAPS 0427.
18. REEL NOT TO EXCEED 35 LBS.
19. SHARP CORNERS TO BE R0.15mm UNLESS OTHERWISE SPECIFIED.
- ⑯ LOCATE PROFILE OF SURFACE ( ) WITH FIXTURE PART NUMBER 693-1181-000.
21. ALL DIMS NOT SHOWN SHALL BE ACCORDING TO SOLID MODEL P1199-4P-DC-WAFER-A-PRELD.
- ⑰ LAST DIGIT OF PART NUMBER IDENTIFIES PLATING CODE, PER EGS 205.  
D = 769  
E = 768  
H = 806  
J = 805

TOLERANCES	DESIGN	10/02/2010 M.RECEPUTO	<b>Amphenol TCS</b> A Division of Amphenol Corporation 200 Innovative Way, Nashua, NH 03062 603.878.3000	TITLE	DC WAFER, OVERMOLDED, A 4 PAIR GbX TW W/O CAPS, .0177" DRILL
0.0 ±0.15	DRAWN	02/28/2011 HCL-MR		PART NO.	SEE TABLE 1 & 2
0.00 ±0.05	CHK	02/28/2011 T.COHEN		DRAWING NO.	P-154-4521-500
0.000 ± -	APVD	02/28/2011 T.COHEN		ASSEM: P1199-4P-DC-WAFER-A-PRELD	1.21
ANGLES ± 1°			DRAWING: P-154-4521-500	C.O	
UNLESS OTHERWISE SPECIFIED DIMENSIONS ARE IN MM, DECIMAL MARKER IS A PERIOD. THESE DRAWINGS AND SPECIFICATIONS ARE THE PROPERTY OF AMPHENOL CORPORATION AND SHALL NOT BE REPRODUCED OR COPIED OR USED AS THE BASIS FOR THE MANUFACTURE OR SALE OF APPARATUS WITHOUT THE WRITTEN PERMISSION OF AMPHENOL CORPORATION.			SCALE	5/1	
MATERIAL: ①  INTERPRET PER ASME Y14.5M CODE IDENT 31413			SHEET	1 OF 5	

DRW NO. P-154-4521-500

SH 1 REV C

8

7

6

5

4

3

DRW NO.	P-154-4521-500	SH	2	REV	C
---------	----------------	----	---	-----	---

ZONE	REV	SCR NUMBER	DESCRIPTION	BY	DATE	APPROVED
			SEE SHEET 1			

D

C

B

A

D

C

B

A

SIGNAL LEADFRAME  
CARRIER STRIP

154-4321-XXX

15  
13X 2.13  
MAX ALLOWABLE  
COMPLIANT PIN SHIFT  
(DUE FROM PREP AND  
OVERMOLD PROCESSES)

160-0808-XXX

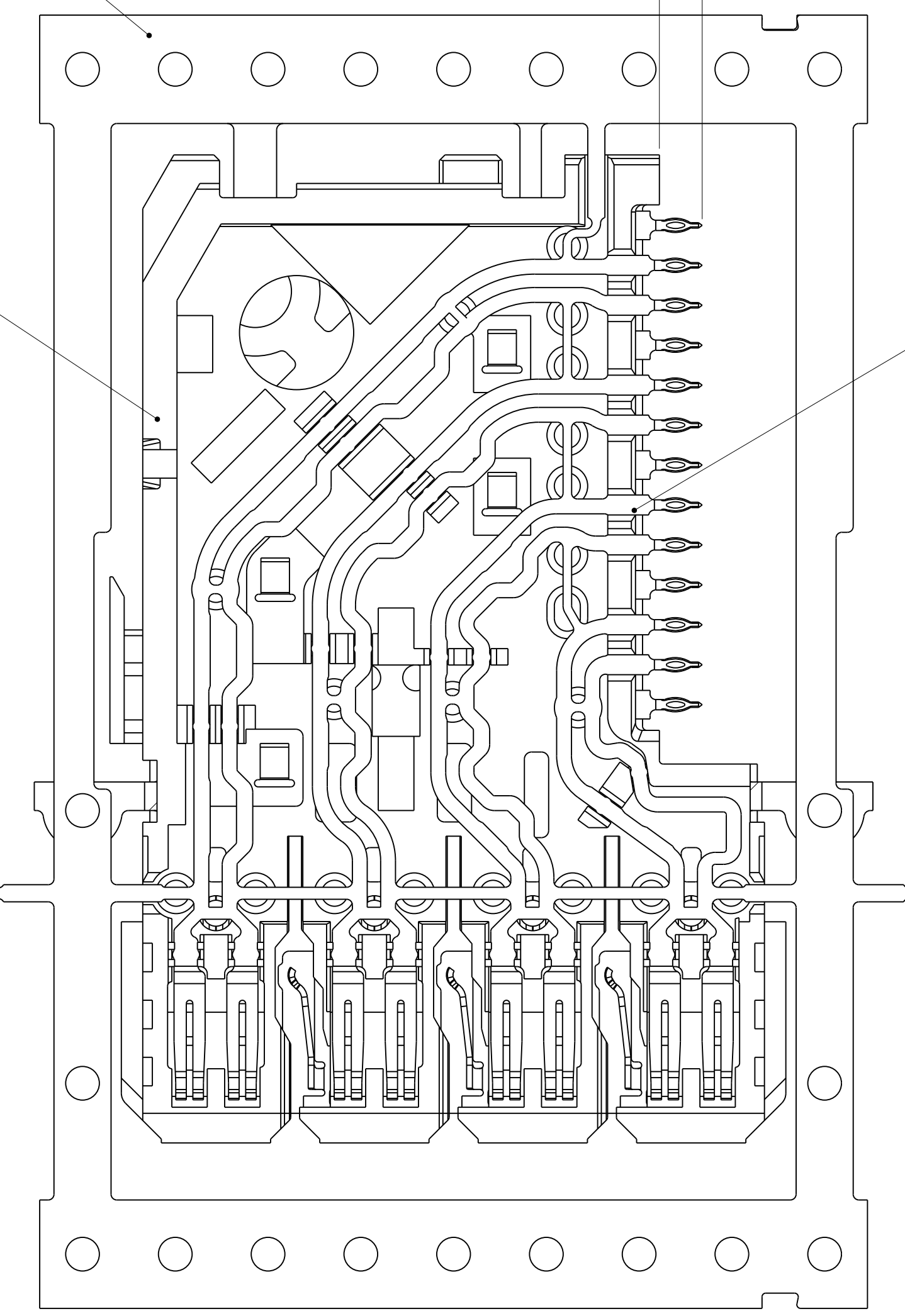

PRE-PEP STATION WAFER  
154-4421-XXX

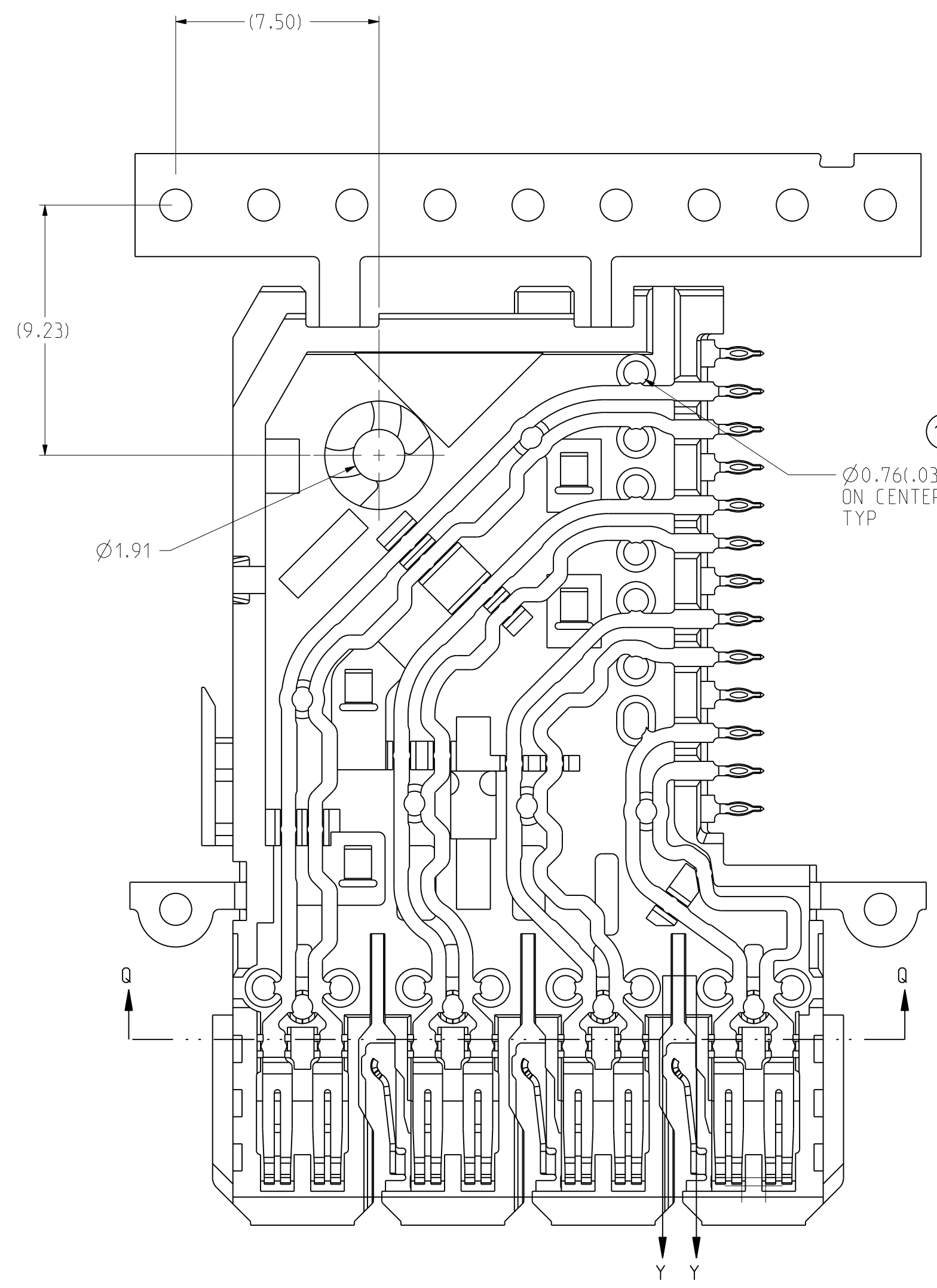

PREPPED (154-4421-XXX) WAFER PRIOR TO OVERMOLD  
(TIE BARS HAVE BEEN REMOVED)

16  
Ø0.76(.030" PUNCH) THRU  
ON CENTER WITH SHIELD HOLES  
TYP

17  
3X 0.51±0.10

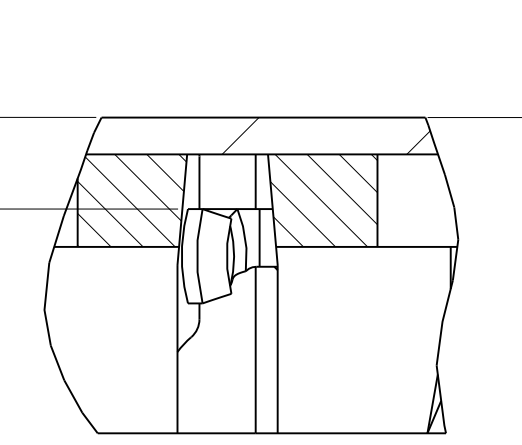

SECTION Y-Y  
SCALE 24:1

71  
8X (0.92)  
FEATURES TO BE SEATED  
FLUSH AGAINST PLASTIC

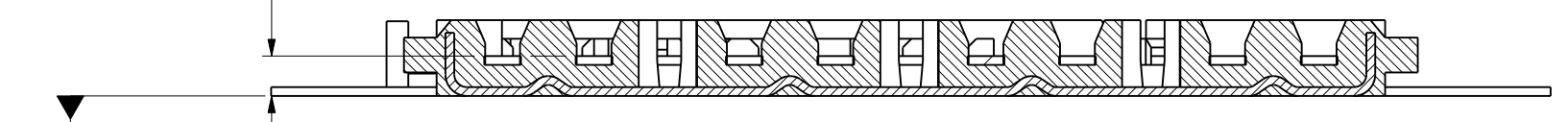

SECTION Q-Q

TOLERANCES	DESIGN	DATE	DESIGNER
0.0 ±0.15	10/02/2010		M.RECEPUTO
0.00 ±0.05	02/28/2011		HCL-MR
0.000 ± -	02/28/2011		T.COHEN
ANGLES ± 1°	02/28/2011		T.COHEN

**Amphenol TCS**  
A Division of Amphenol Corporation  
200 Innovative Way, Nashua, NH 03062 603.878.3000

TITLE  
DC WAFER, OVERMOLDED, A  
4 PAIR GbX TW W/O CAPS, .0177" DRILL

MATERIAL: INTERPRET PER ASME Y14.5M  
CODE IDENT 31413

UNLESS OTHERWISE SPECIFIED DIMENSIONS ARE IN MM, DECIMAL MARKER IS A PERIOD.  
THESE DRAWINGS AND SPECIFICATIONS ARE THE PROPERTY OF AMPHENOL CORPORATION AND SHALL NOT BE REPRODUCED OR COPIED OR USED AS THE BASIS FOR THE MANUFACTURE OR SALE OF APPARATUS WITHOUT THE WRITTEN PERMISSION OF AMPHENOL CORPORATION.

PART NO.	SEE TABLE 1 & 2	REV	
DRAWING NO.	P-154-4521-500	REV	C
ASSEM.	P1199-4P-DC-WAFER-A-PRELD	1.21	
DRAWING	P-154-4521-500	C.0	
SIZE	D	SCALE	6/1
		SHEET	2 OF 5

8

7

6

5

4

3

2

1

DRW NO.  
P-154-4521-500

SH

2

REV

C

DRW NO.	P-154-4521-500	SH	3	REV	C	
ZONE	REV	SCR NUMBER	DESCRIPTION	BY	DATE	APPROVED
			SEE SHEET 1			

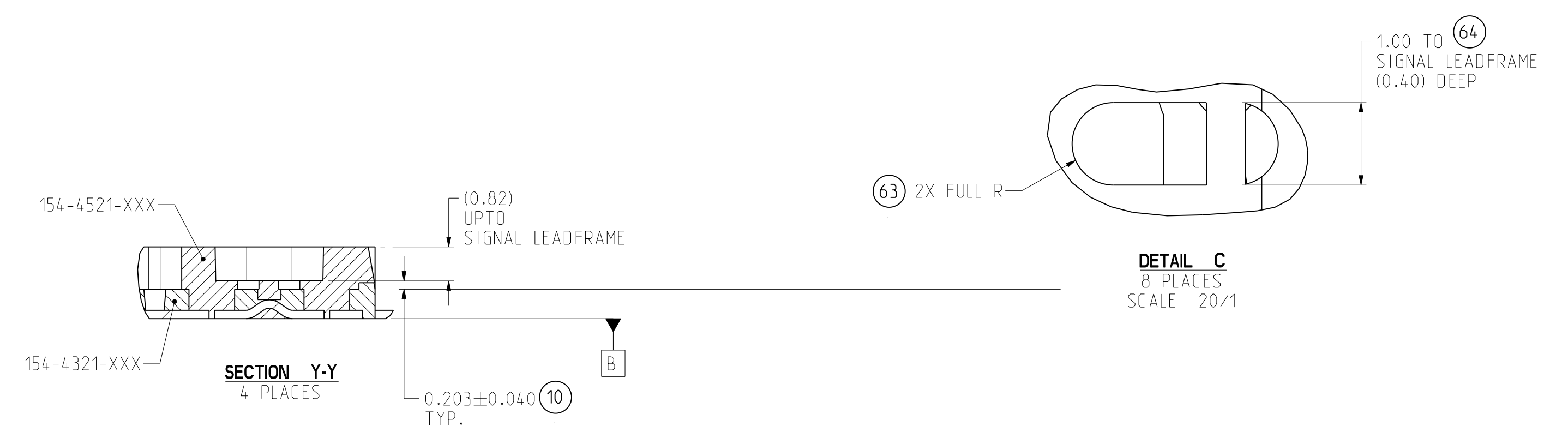
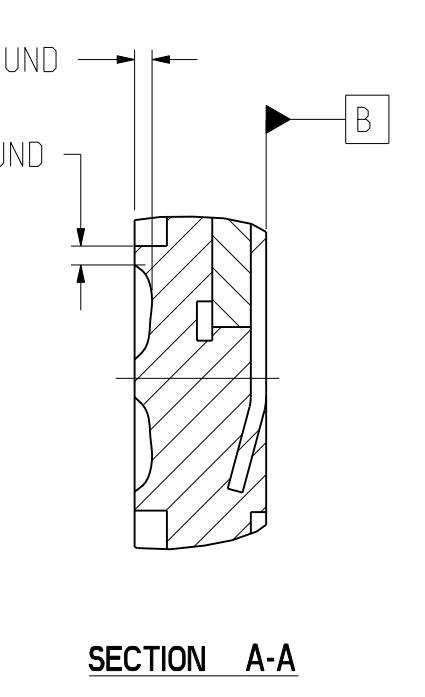
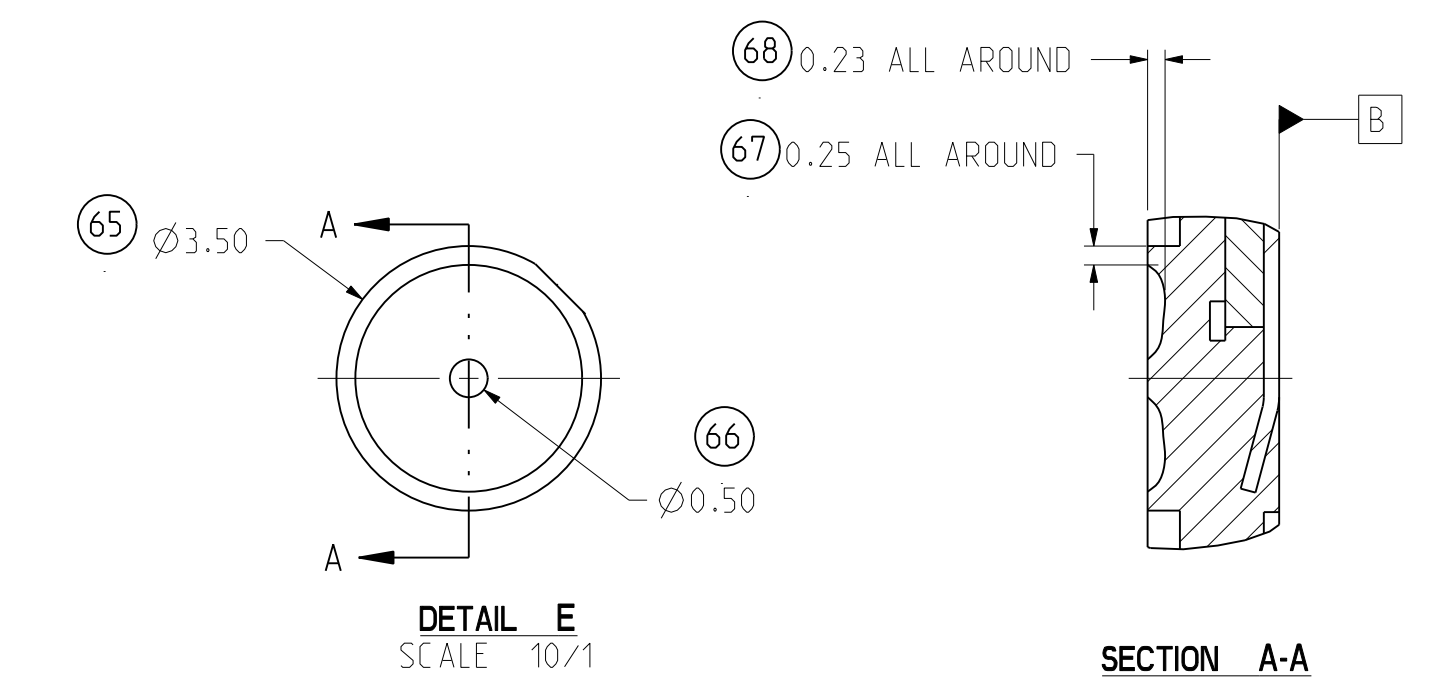
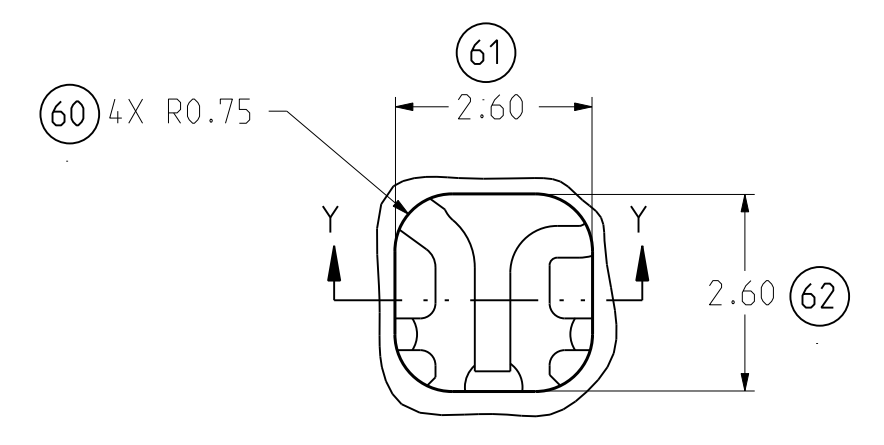
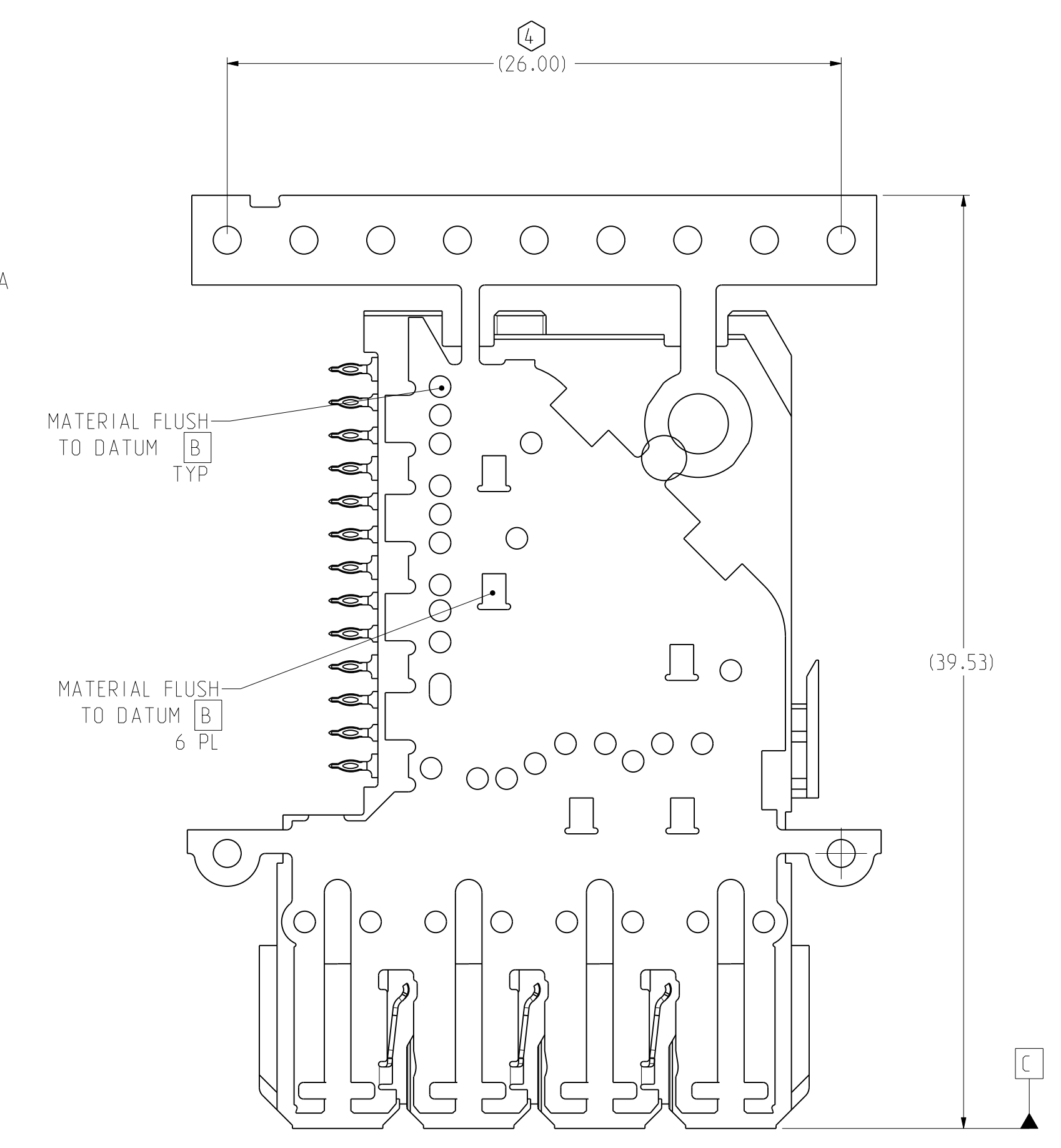
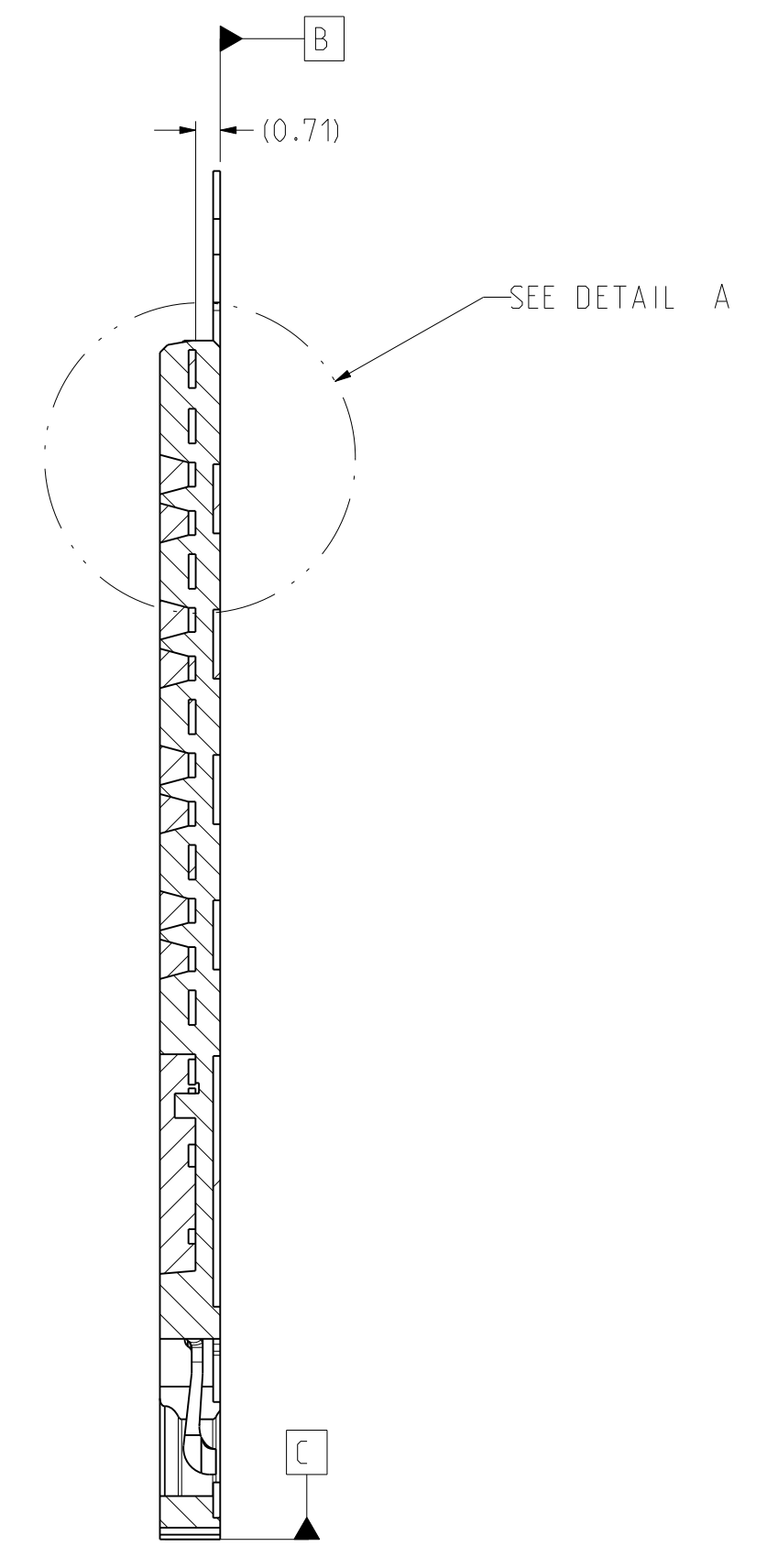
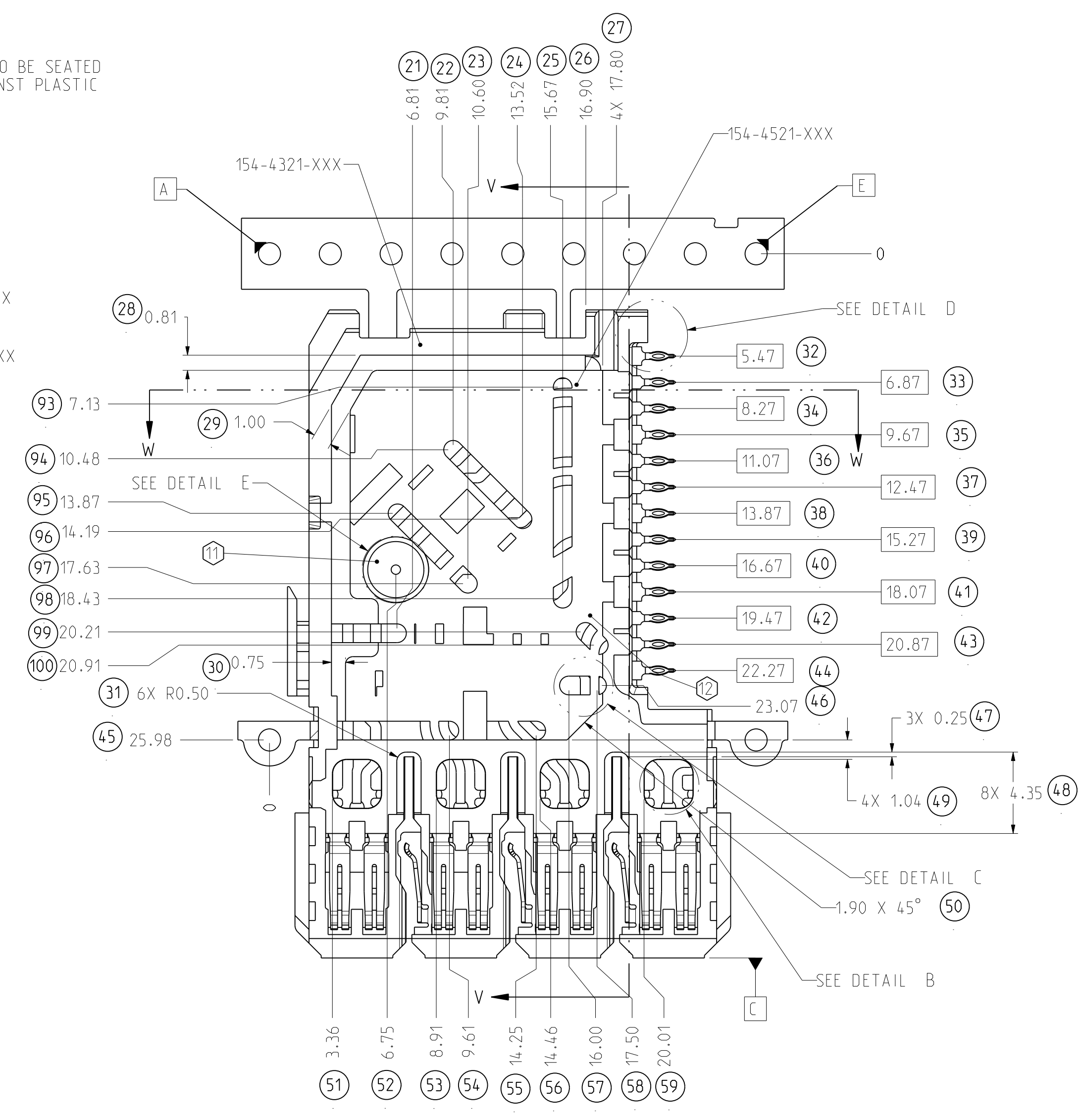
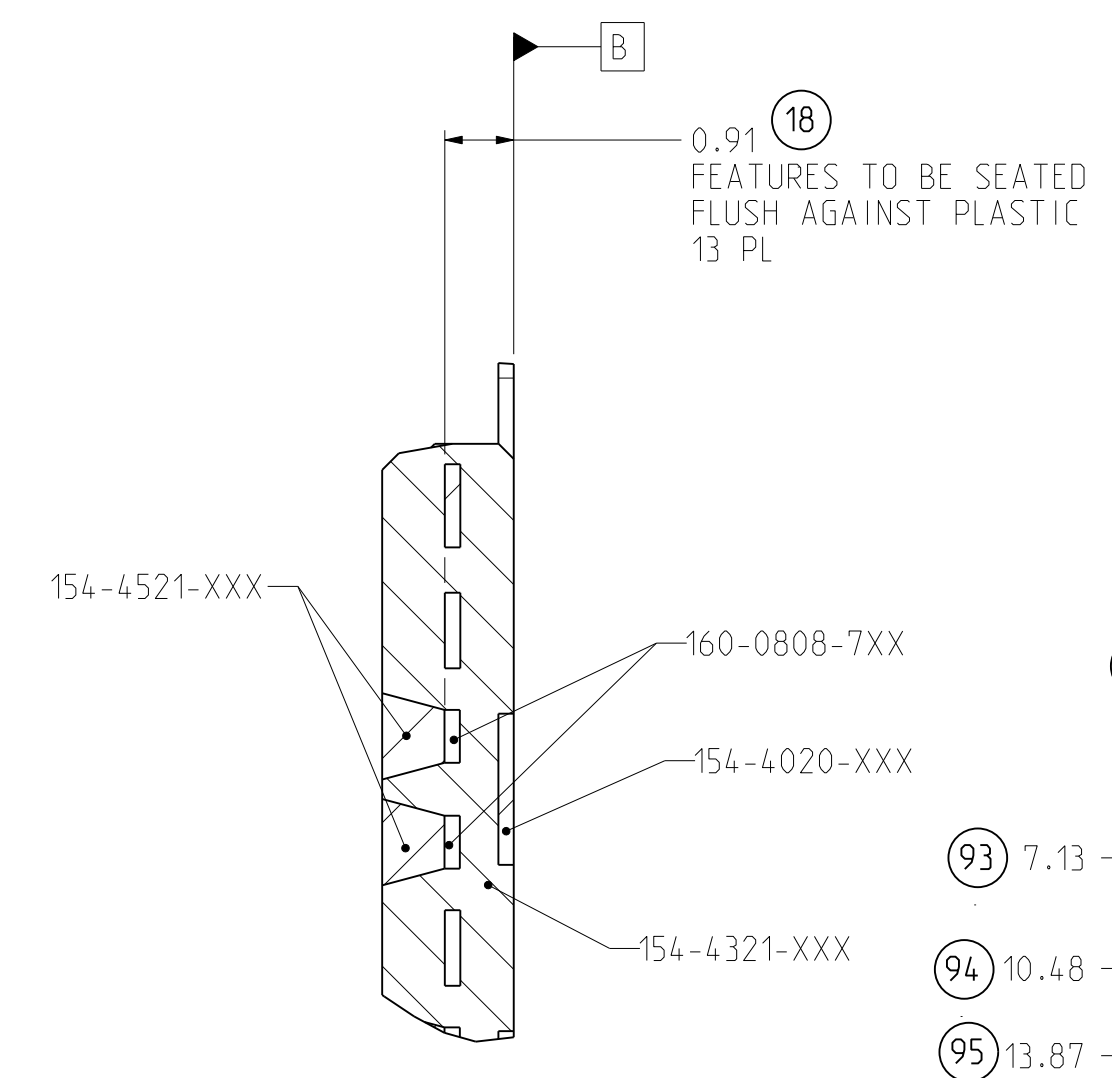
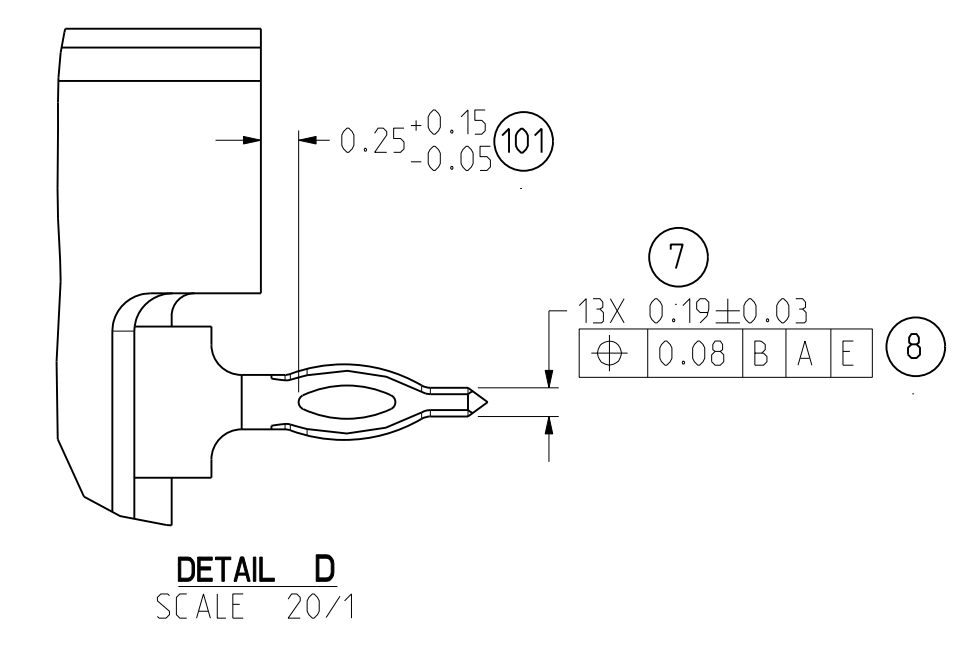
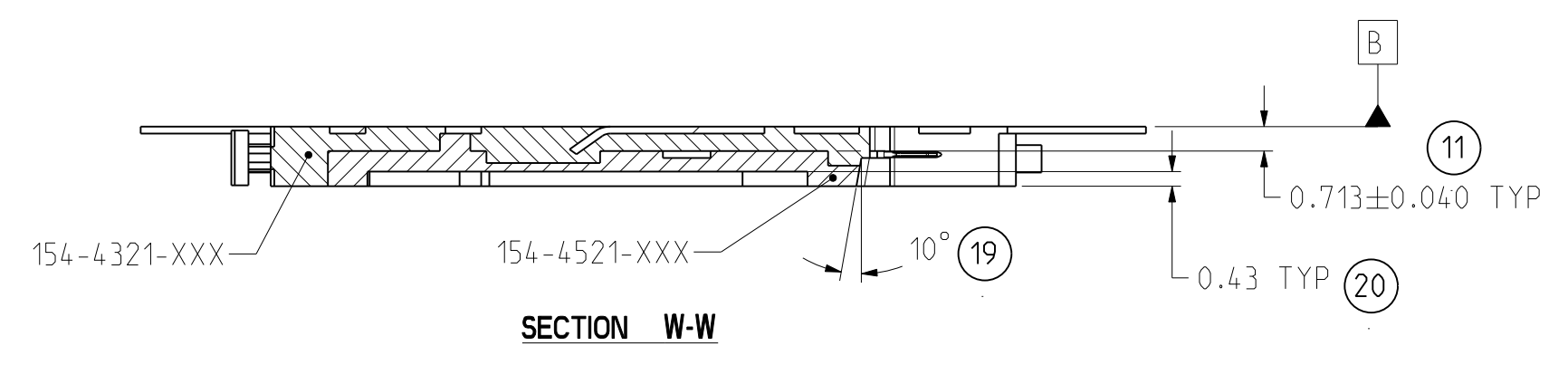

TOLERANCES		DESIGN	10/02/2010	M.RECEPUTO	
0.0	±0.15	DRAWN	02/28/2011	HCL-MR	
0.00	±0.05	CHK	02/28/2011	T.COHEN	
0.000	±	APVD	02/28/2011	T.COHEN	
ANGLES	± 1°				

UNLESS OTHERWISE SPECIFIED DIMENSIONS ARE IN MM, DECIMAL MARKER IS A PERIOD		<b>Amphenol TCS</b>	
THESE DRAWINGS AND SPECIFICATIONS ARE THE PROPERTY OF AMPHENOL CORPORATION AND SHALL NOT BE REPRODUCED OR COPIED OR USED AS THE BASIS FOR THE MANUFACTURE OR SALE OF APPARATUS WITHOUT THE WRITTEN PERMISSION OF AMPHENOL CORPORATION.		A Division of Amphenol Corporation 200 Innovative Way, Nashua, NH 03062 603.878.3000	
MATERIAL: 1		TITLE: DC WAFER, OVERMOLDED, A 4 PAIR GbX TW W/D CAPS. .0177" DRILL	
INTERPRET PER ASME Y14.5M		PART NO. SEE TABLE 1 & 2	
CODE IDENT 31413		DRAWING NO. P-154-4521-500	
		ASSEM. P1199-4P-DC-WAFER-A-PRELD 1.21	
		DRAWING: P-154-4521-500 C.O	
		SIZE D SCALE 5/1 SHEET 3 OF 5	

DRW NO. P-154-4521-500

SH 3  
REV C

ZONE	REV	SCR NUMBER	DESCRIPTION	BY	DATE	APPROVED
			SEE SHEET 1			

D  
C  
B  
A

D  
C  
B  
A

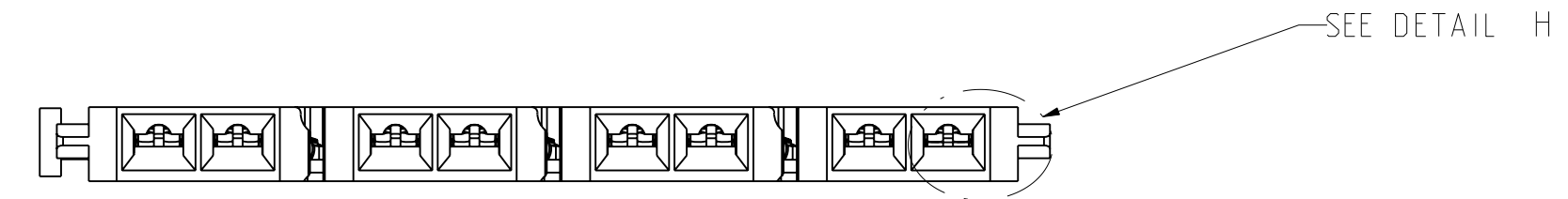
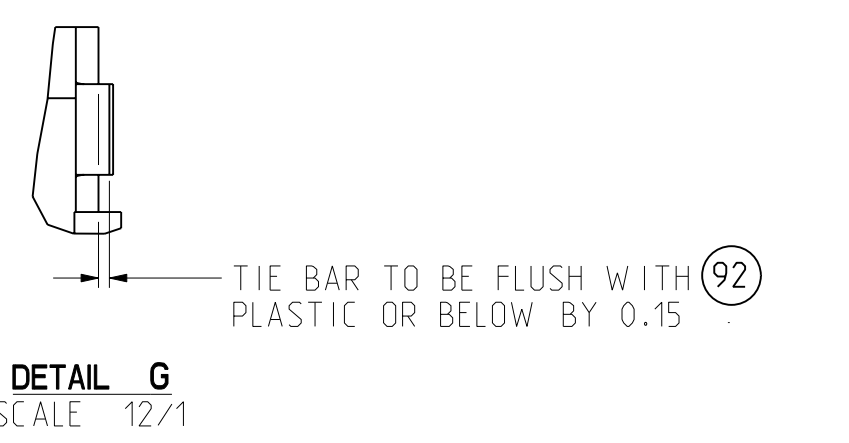
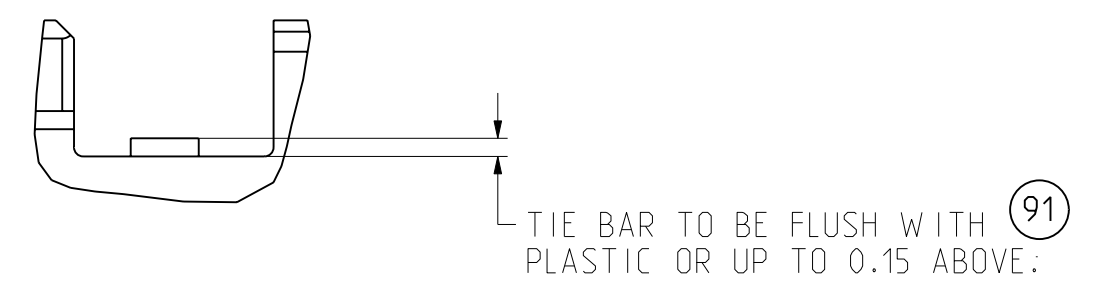
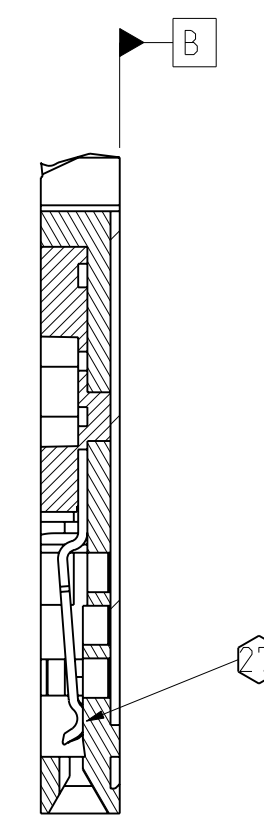
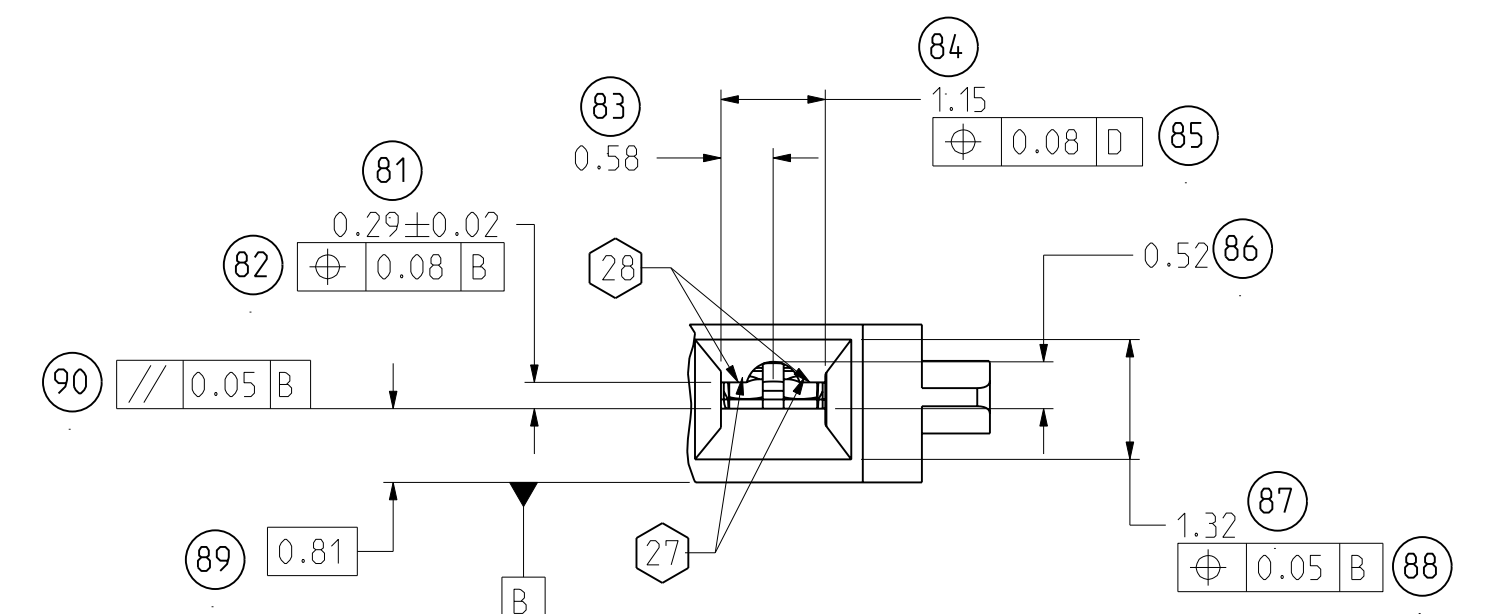
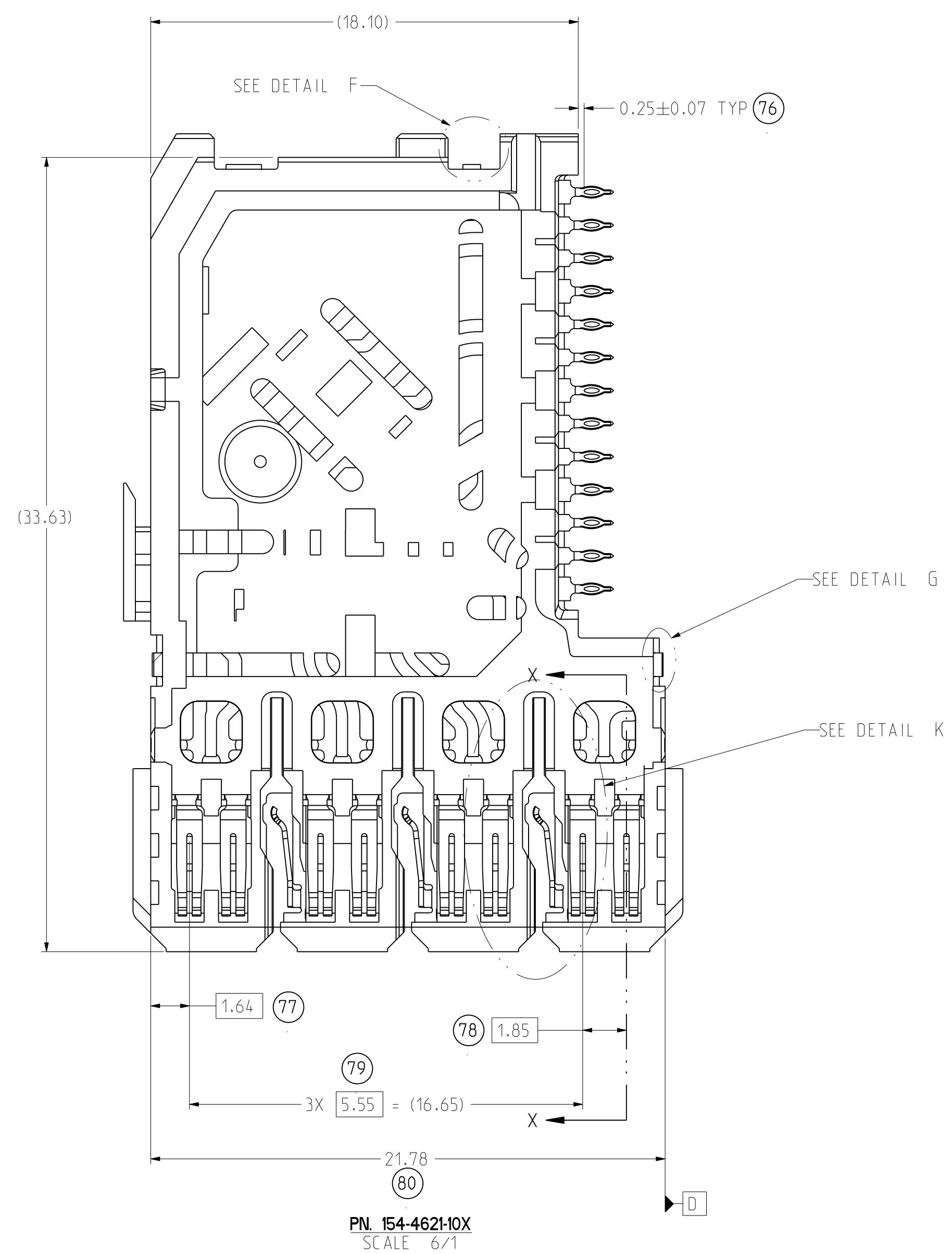
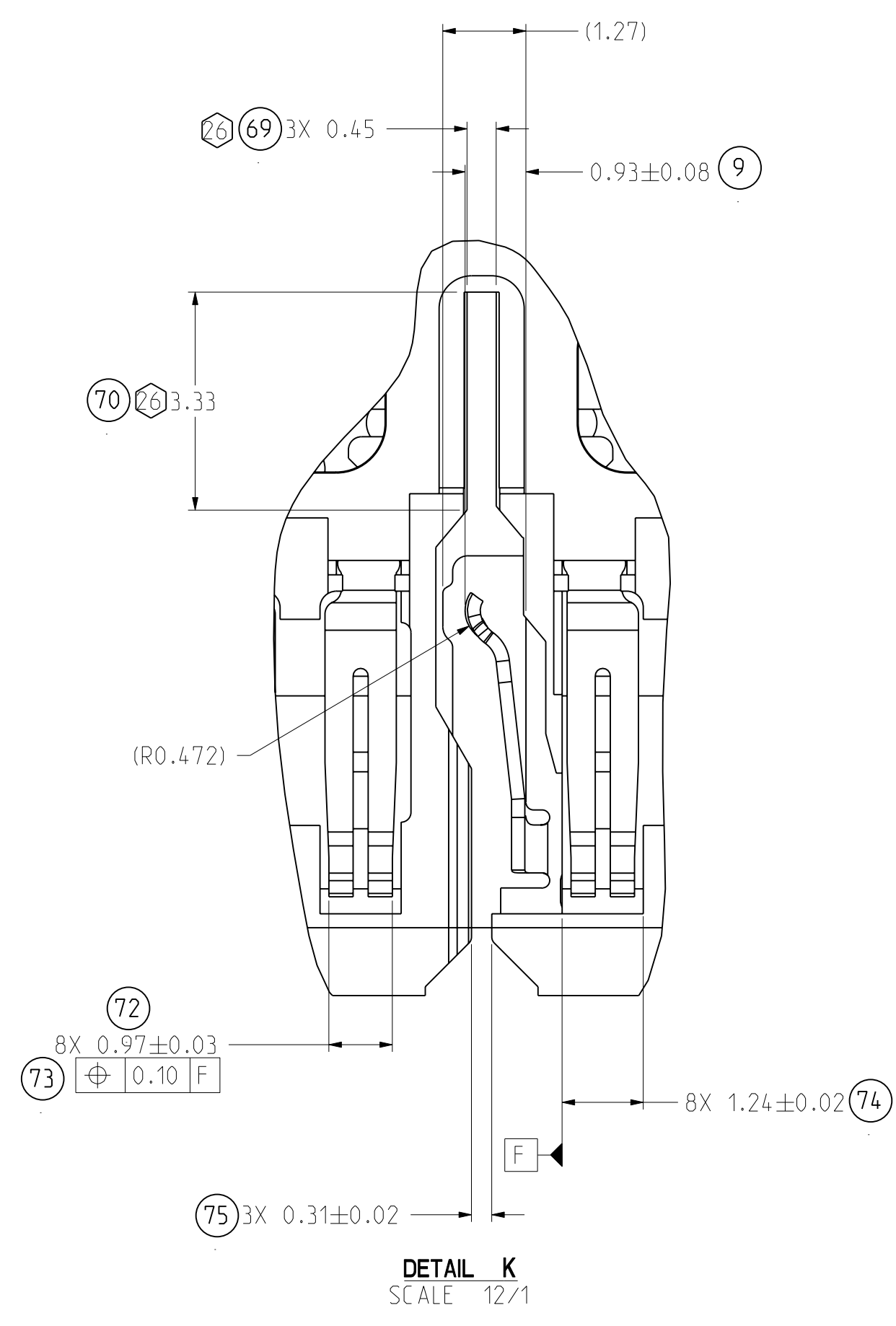

- 24. ALL WAFERS TO BE ELECTRICALLY CHECKED FOR CONTINUITY AND HIPOT TESTED.
- 25. LOCATE SURFACE WITH FIXTURE PART NUMBER 693-1181-000.
- 26. EXPOSED METAL MUST BE PRESENT IN SLOT
- 27. BEAM MATING RADIUS ON PLASTIC.
- 28. NO BEAM TIPS VISIBLE IN WINDOW.

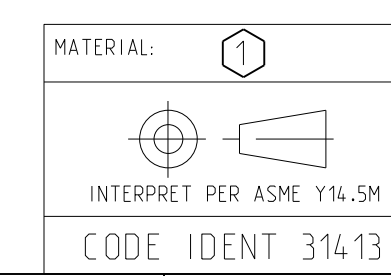

TOLERANCES	DESIGN	DATE	DESIGNER
0.0 ±0.15	10/02/2010		M.RECEPUTO
0.00 ±0.05	02/28/2011		HCL-MR
0.000 ± -	02/28/2011		T.COHEN
ANGLES ± 1°	02/28/2011		T.COHEN

<b>Amphenol TCS</b> A Division of Amphenol Corporation 200 Innovative Way, Nashua, NH 03062 603.878.3000		TITLE DC WAFER, OVERMOLDED, A 4 PAIR GbX TW W/O CAPS, .0177" DRILL	
		PART NO. SEE TABLE 1 & 2	
DRAWING NO. P-154-4521-500		REV C	
ASSEM: P1199-4P-DC-WAFER-A-PRELD DRAWING: P-154-4521-500		SCALE 6/1	
SIZE D		SHEET 4 OF 5	

ZONE	REV	SCR NUMBER	DESCRIPTION	BY	DATE	APPROVED
			SEE SHEET 1			

**FIRST PIECE INSPECTION REQUIREMENTS**

ITEM	FEATURE	METHOD	NOTES
1	CORRECT REEL NO. AND ORIENTATION	VISUAL	
2	BEAM MATING RADIUS ON PLASTIC	VISUAL	
3	NO BEAM TIPS IN WINDOW	VISUAL	
4	FLASH PER NOTES ② & ③	VISUAL	
5	CAMBER/TWIST/COILSET PER EGPS-201	VISUAL	
6	COMPLIANT COIN RADIUS	VISUAL	

• ALL BALLOONED DIMENSIONS IN THIS SHEET MUST HAVE AN ACTUAL MEASUREMENT VALUE  
 NOTES:  
 ②③ THESE FEATURES MUST BE MEASURED IN-PROCESS USING SPC.

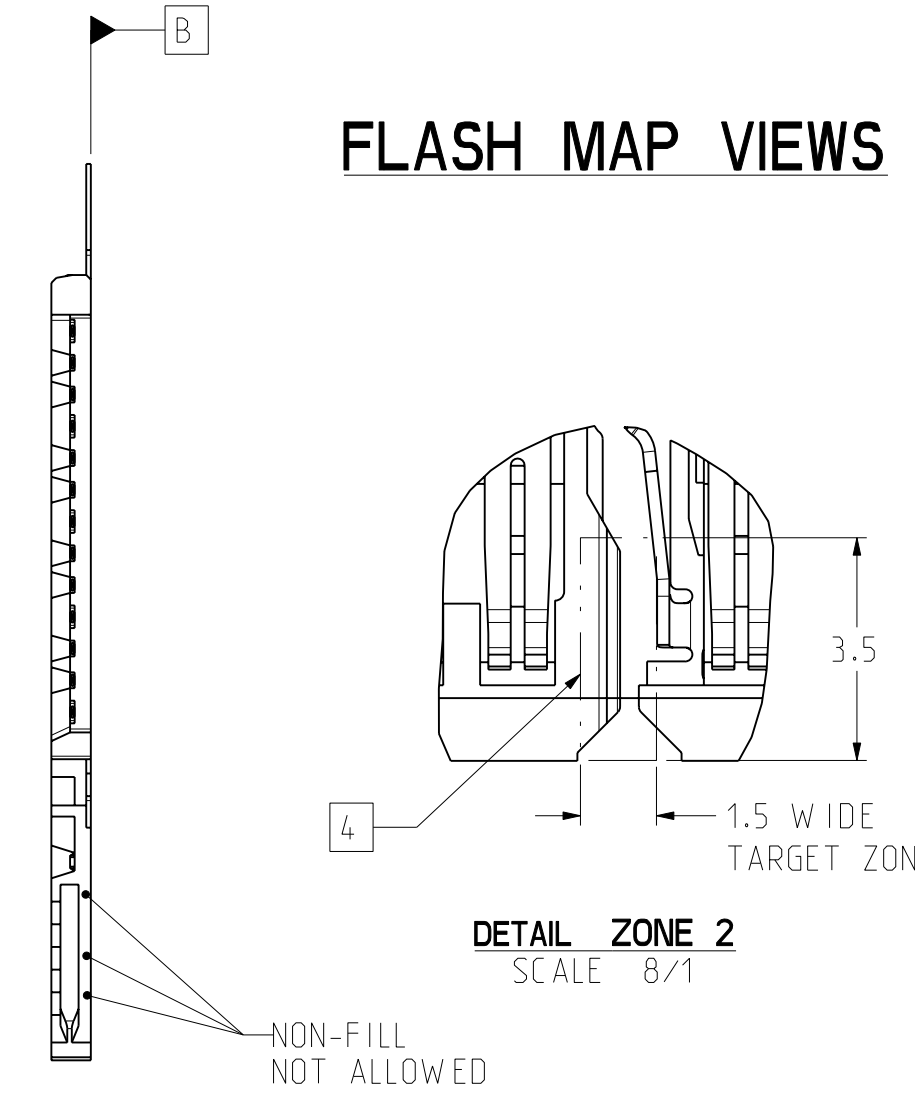
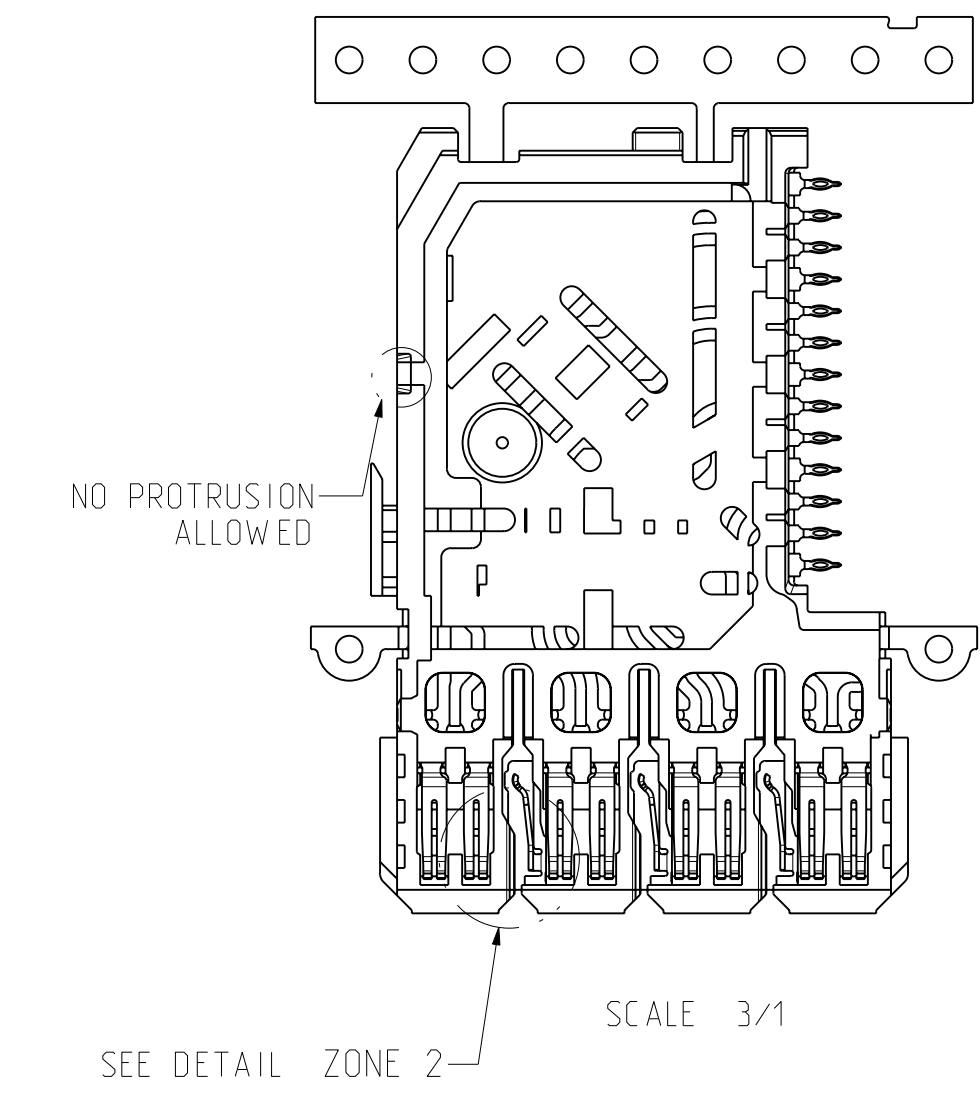
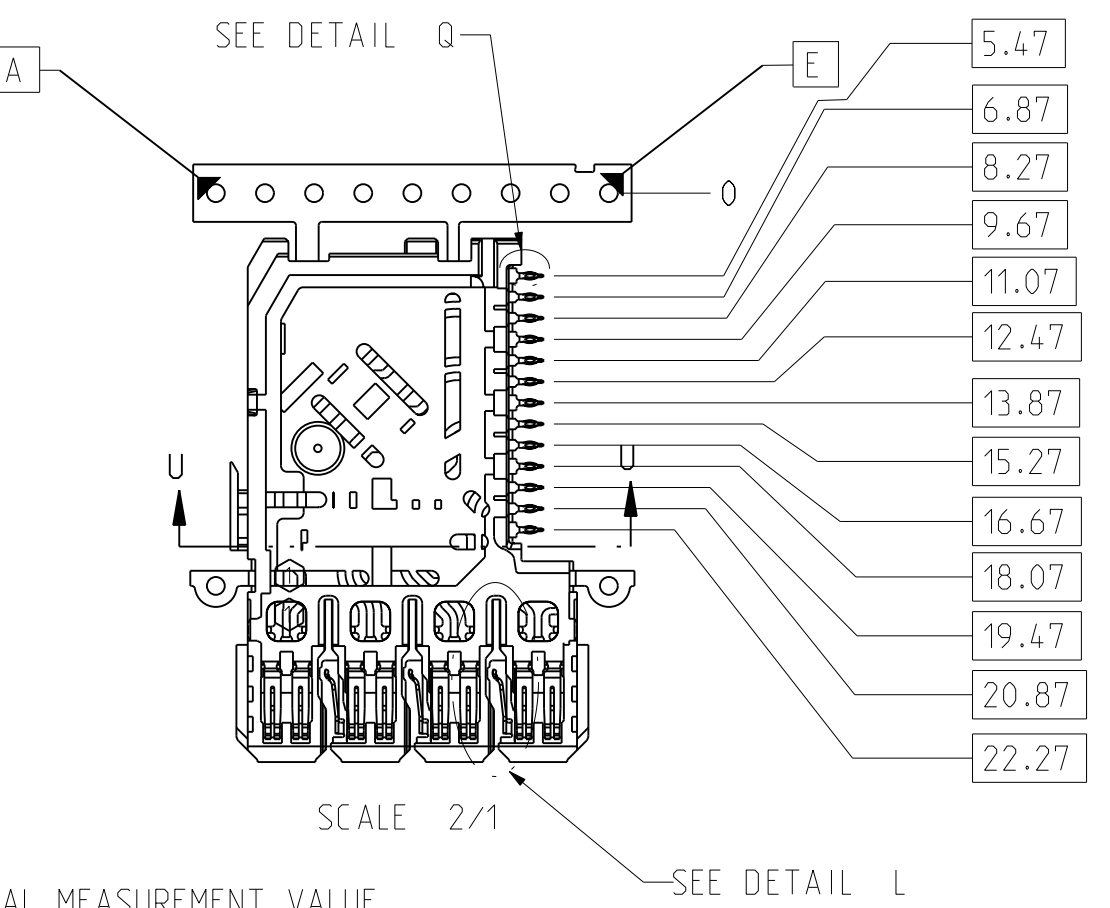

REEL P/N: 801-1449-000  
 INTERLEAF PAPER P/N: 801-1248-000

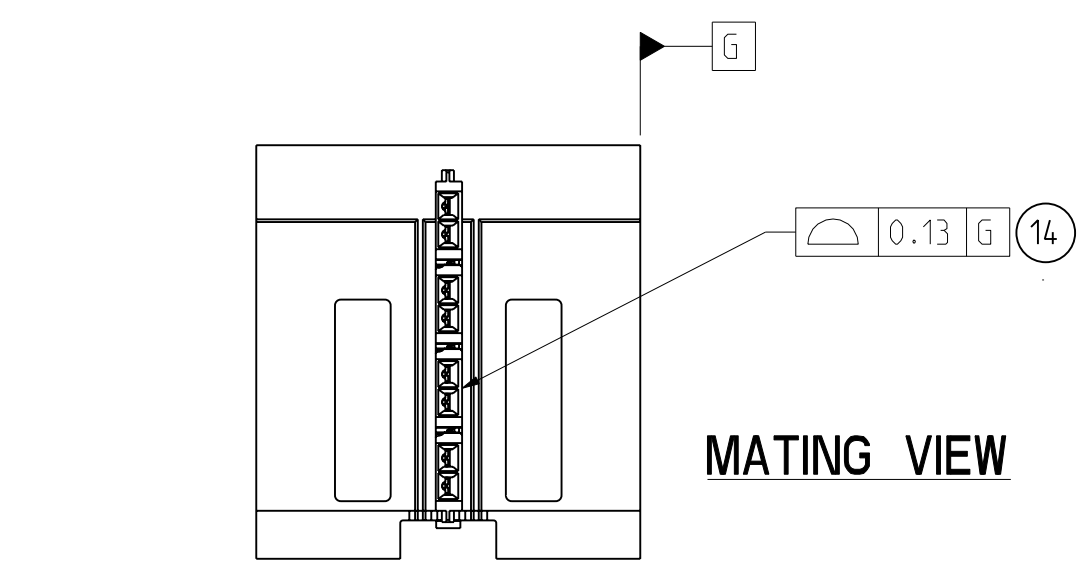
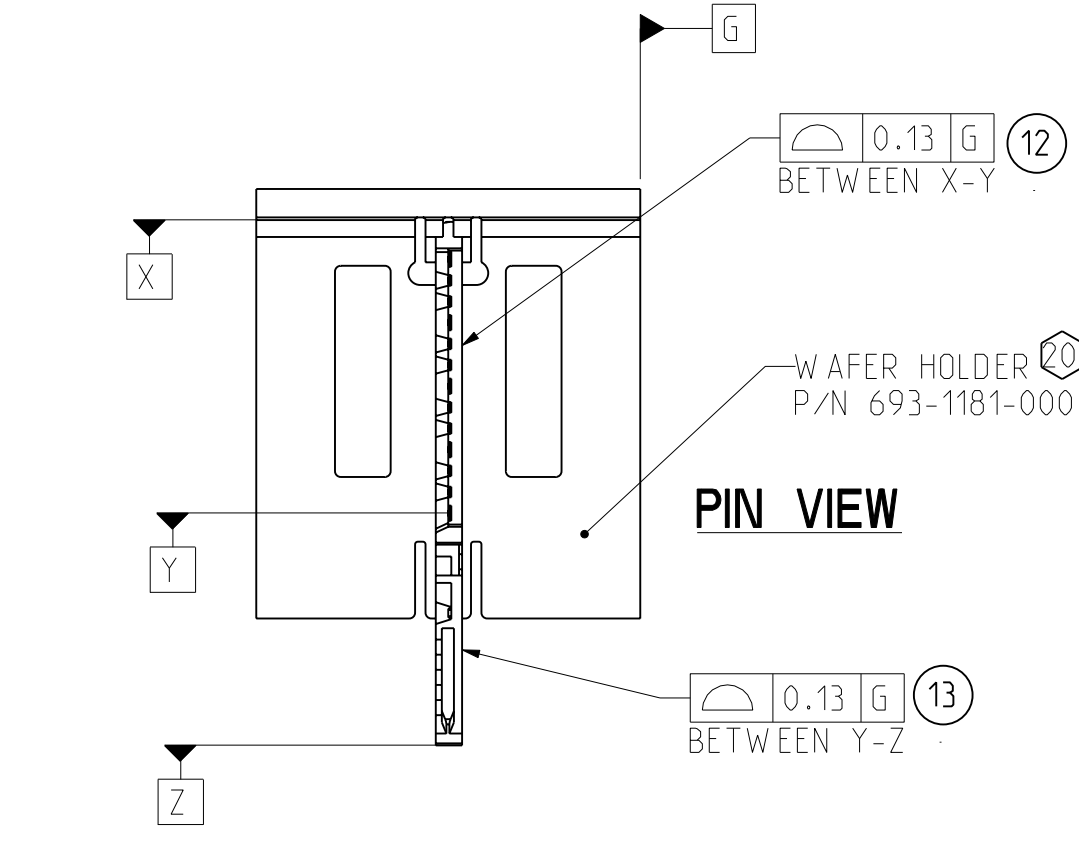
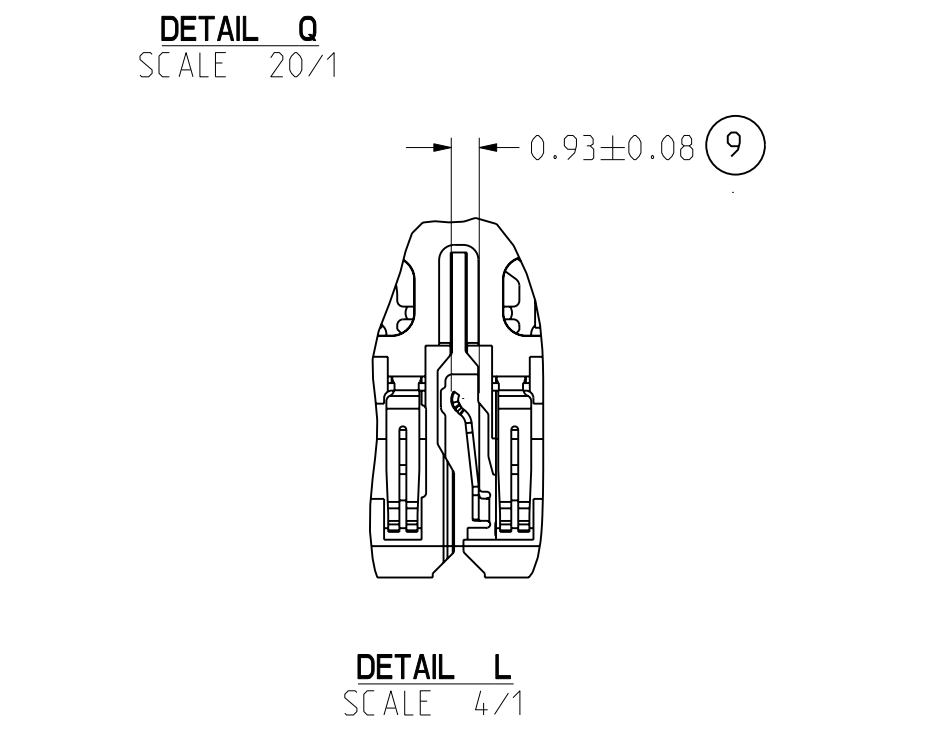
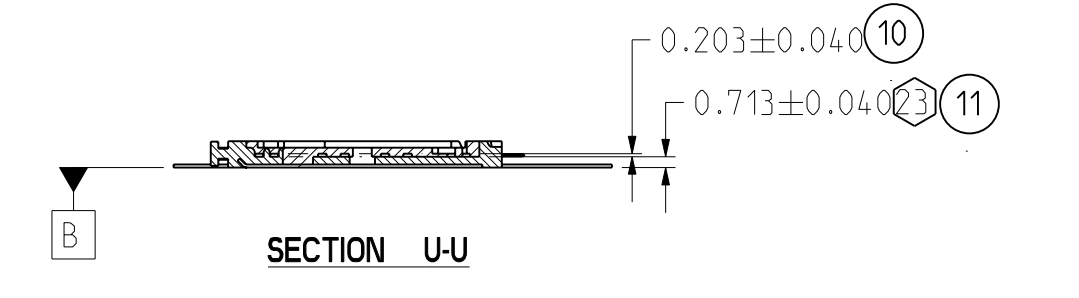
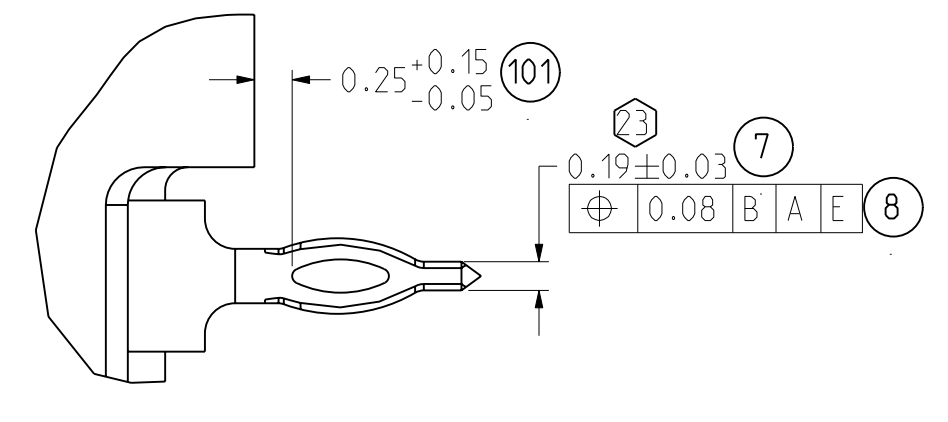
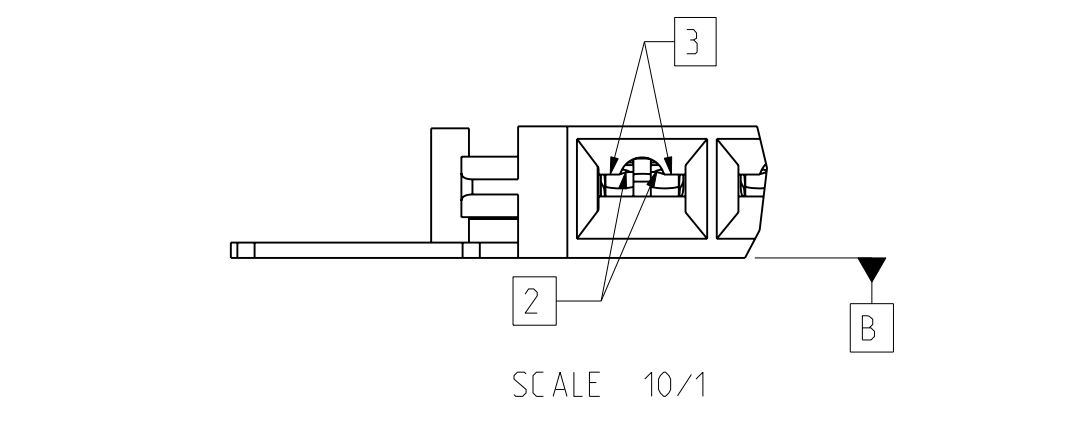

- GENERAL SPECIFICATIONS  
 0.20 FLASH ACCEPTABLE
- ① WINDOW FLASH .05 MAX
  - ② .10 MAX
  - ③ .10 MAX
  - ④ .30 MAX SEE NOTE 1

NOTE:  
 1. FLASH NOT TO EXCEED OVERALL THICKNESS SPECIFICATIONS

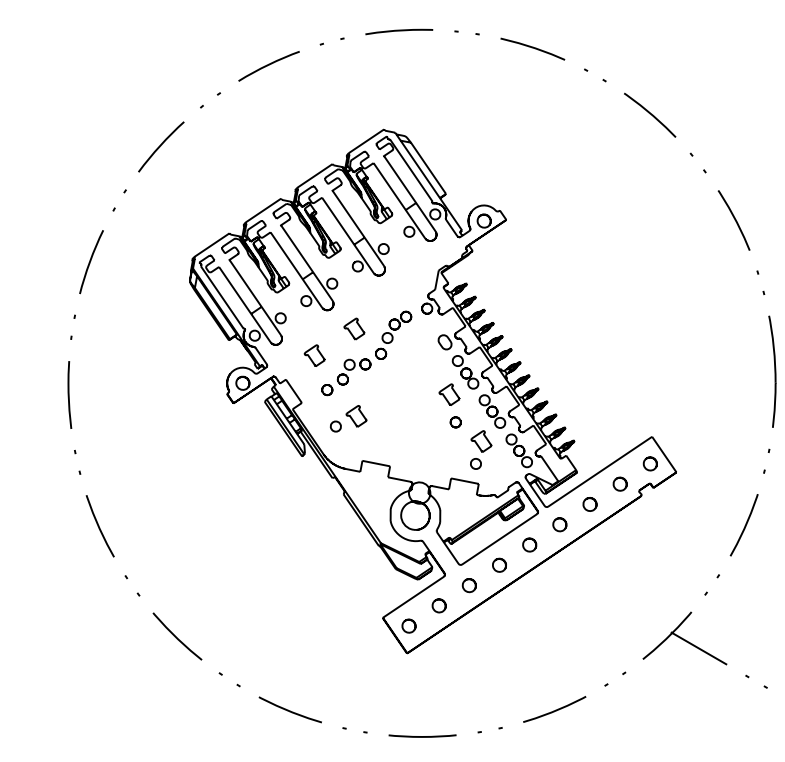

SCALE 1/2

PROFILE MEASURING TECHNIQUE

TOLERANCES	DESIGN	DATE	DESIGNER	Amphenol TCS	
0.0	±0.15	10/02/2010	M.RECEPUTO	A Division of Amphenol Corporation	
0.00	±0.05	02/28/2011	HCL-MR	200 Innovative Way, Nashua, NH 03062 603.878.3000	
0.000	± -	02/28/2011	T.COHEN	TITLE DC WAFER, OVERMOLDED, A 4 PAIR GbX TW W/O CAPS, .0177" DRILL	
ANGLES	± 1°	02/28/2011	T.COHEN	PART NO. SEE TABLE 1 & 2	
MATERIAL: ①				DRAWING NO. P-154-4521-500	
UNLESS OTHERWISE SPECIFIED DIMENSIONS ARE IN MM, DECIMAL MARKER IS A PERIOD				REV C	
THESE DRAWINGS AND SPECIFICATIONS ARE THE PROPERTY OF AMPHENOL CORPORATION AND SHALL NOT BE REPRODUCED OR COPIED OR USED AS THE BASIS FOR THE MANUFACTURE OR SALE OF APPARATUS WITHOUT THE WRITTEN PERMISSION OF AMPHENOL CORPORATION.				ASSEM: P1199-4P-DC-WAFER-A-PRELD 1.21	
INTERPRET PER ASME Y14.5M				DRAWING: P-154-4521-500 C.0	
CODE IDENT 31413				SIZE D SCALE 6/1 SHEET 5 OF 5	

DRW NO. P-154-4521-500

SH 5 REV C

Компания «Океан Электроники» предлагает заключение долгосрочных отношений при поставках импортных электронных компонентов на взаимовыгодных условиях!

Наши преимущества:

- Поставка оригинальных импортных электронных компонентов напрямую с производств Америки, Европы и Азии, а так же с крупнейших складов мира;
- Широкая линейка поставок активных и пассивных импортных электронных компонентов (более 30 млн. наименований);
- Поставка сложных, дефицитных, либо снятых с производства позиций;
- Оперативные сроки поставки под заказ (от 5 рабочих дней);
- Экспресс доставка в любую точку России;
- Помощь Конструкторского Отдела и консультации квалифицированных инженеров;
- Техническая поддержка проекта, помощь в подборе аналогов, поставка прототипов;
- Поставка электронных компонентов под контролем ВП;
- Система менеджмента качества сертифицирована по Международному стандарту ISO 9001;
- При необходимости вся продукция военного и аэрокосмического назначения проходит испытания и сертификацию в лаборатории (по согласованию с заказчиком);
- Поставка специализированных компонентов военного и аэрокосмического уровня качества (Xilinx, Altera, Analog Devices, Intersil, Interpoint, Microsemi, Actel, Aeroflex, Peregrine, VPT, Syfer, Eurofarad, Texas Instruments, MS Kennedy, Miteq, Cobham, E2V, MA-COM, Hittite, Mini-Circuits, General Dynamics и др.);

Компания «Океан Электроники» является официальным дистрибьютором и эксклюзивным представителем в России одного из крупнейших производителей разъемов военного и аэрокосмического назначения «JONHON», а так же официальным дистрибьютором и эксклюзивным представителем в России производителя высокотехнологичных и надежных решений для передачи СВЧ сигналов «FORSTAR».



## JONHON

«JONHON» (основан в 1970 г.)

Разъемы специального, военного и аэрокосмического назначения:

(Применяются в военной, авиационной, аэрокосмической, морской, железнодорожной, горно- и нефтедобывающей отраслях промышленности)

«FORSTAR» (основан в 1998 г.)

ВЧ соединители, коаксиальные кабели, кабельные сборки и микроволновые компоненты:

(Применяются в телекоммуникациях гражданского и специального назначения, в средствах связи, РЛС, а так же военной, авиационной и аэрокосмической отраслях промышленности).



Телефон: 8 (812) 309-75-97 (многоканальный)

Факс: 8 (812) 320-03-32

Электронная почта: [ocean@oceanchips.ru](mailto:ocean@oceanchips.ru)

Web: <http://oceanchips.ru/>

Адрес: 198099, г. Санкт-Петербург, ул. Калинина, д. 2, корп. 4, лит. А