

MAX33251E Shield

Evaluates: MAX33251E

General Description

The MAX33251E Shield is a fully assembled and tested PCB that demonstrates the functionality of the MAX33251E, isolated 1Tx/1Rx RS-232 transceiver, with a galvanic isolation of 600V_{RMS} (60s) between the logic UART side and field side. The isolation barrier protects the logic UART side from electrical transient strikes from the field side. It also breaks ground loops and large differences in ground potentials between the two sides that can corrupt the receiving and sending of data. The MAX33251E conforms to the EIA/TIA-232E standard and operates at data rates up to 1Mbps.

Features

- Single Supply
- On-Board Isolated DC-DC Power Supply
- Arduino/Mbed Shield Interface Form Factor
- DCE/DTE Selectable DB9 Pinout

Ordering Information appears at end of data sheet.

Quick Start

Required Equipment

- MAX33251E Shield
- 5V, 500mA DC power supply
- Function generator
- Digital oscilloscope

Procedure

The Shield EV kit is fully assembled and tested. Follow the steps below to verify board operation:

- 1) Place the MAX33251E Shield on a nonconductive surface to ensure that nothing on the PCB gets shorted to the workspace.
- 2) Connect T1OUT test point to R1IN test point.
- 3) Disable the output of the function generator.
- 4) Set the output of the function generator to 500kHz (min = 0V, max = 5V) square wave.
- 5) Connect the positive terminal of the function generator to D2 on J6.
- 6) Connect the negative terminal of the function generator to GNDA connector.
- 7) Connect the positive terminal of 5V supply to VCCA_EXT and VCCB_EXT connectors.
- 8) Connect the negative terminal of 5V supply to GNDA and GNDB connectors.
- 9) Connect the positive terminal of 5V supply to pin 7 of the J3 connector (IOREF)
- 10) Connect the positive terminal of channel 1 of the oscilloscope to D3 on J6.
- 11) Connect the negative terminal of channel 1 of the oscilloscope to GNDA connector.
- 12) Enable the output of the function generator.
- 13) Verify 500kHz 5V square waves appear on oscilloscope.

Detailed Description of Hardware

MAX33251E Shield is a fully assembled and tested circuit board for evaluating the MAX33251E 1Mbps, 600V_{RMS} isolated RS-232 transceivers. The MAX33251E has a transmitter and a receiver (1Tx/1Rx). The isolation is provided by Maxim’s proprietary insulation material that can withstand 600V_{RMS} for 60 seconds. The MAX33251E conforms to the EIA/TIA-232 standard and operates at data rates up to 1Mbps over the temperature range of -40°C to +85°C.

The MAX33251E Shield with an on-board DB9 connector, enables Mbed or Arduino platform to communicate on a RS-232 bus. DCE/DTE DB9 pin out is selectable with the SW1 switch. The MAX14850 digital isolator is used as a level translator with a 3V to 5.5V supply range.

To evaluate this device without connecting to a network, a resistive load of 3KΩ to 7KΩ and a capacitive load of 150pF to 1000pF can be placed on R1 and C1, respectively.

Powering the Board

V_{CCA} of MAX33251E can come from external supply or the Arduino/mbed platform supply. See [Table 1](#) for jumper settings to select appropriate V_{CCA} source.

The MAX33251E Shield has an on-board isolated power supply that generates an isolated supply for V_{CCB}. If the shield board is connected to an Arduino/mbed platform, input of the isolated power supply is connected to the 5V output (pin 4 of J3) of the Arduino/mbed platform. The voltage generated on the isolated output is the same as the input. See [Table 1](#) for jumper settings to select appropriate V_{CCB} source.

The isolated supply generated by the transformer driver requires a 5V supply from the mbed/Arduino board. Set JU1 to 1-3 position to connect mbed/Arduino 5V supply to V_{CCA}.

Table 1. Jumper Settings

JUMPER	SHUNT POSITION	DESCRIPTION
JU1	1-2	Transceiver V _{CCA} connects to 3.3V on Arduino/mbed connector (J3)
	1-3	Transceiver V _{CCA} connects to 5V on Arduino/mbed connector (J3)
	1-4*	Transceiver V _{CCA} connects to V _{CCA_EXT} connector
JU2	1-2	Transceiver V _{CCB} connects to the output of the isolated power supply
	2-3*	Transceiver V _{CCB} connects to V _{CCB_EXT} connector
JU3	1-2*	Transceiver T1IN connects to the level translator
	OPEN	Transceiver T1IN disconnects from the level translator
JU4	1-2*	Transceiver R1OUT connects to the level translator
	OPEN	Transceiver R1OUT disconnects from the level translator
JU5D0	1-2*	Transceiver T1IN connects to Arduino/mbed connector’s D0 signal
	2-3	Transceiver R1OUT connects to Arduino/mbed connector’s D0 signal
	OPEN*	Arduino/mbed connector’s D0 signal is not connected
JU5D1	1-2	Transceiver T1IN connects to Arduino/mbed connector’s D1 signal
	2-3	Transceiver R1OUT connects to Arduino/mbed connector’s D1 signal
	OPEN*	Arduino/mbed connector’s D1 signal is not connected
JU5D2	1-2*	Transceiver T1IN connects to Arduino/mbed connector’s D2 signal
	2-3	Transceiver R1OUT connects to Arduino/mbed connector’s D2 signal
	OPEN	Arduino/mbed connector’s D2 signal is not connected
JU5D3	1-2	Transceiver T1IN connects to Arduino/mbed connector’s D3 signal
	2-3*	Transceiver R1OUT connects to Arduino/mbed connector’s D3 signal
	OPEN	Arduino/mbed connector’s D3 signal is not connected

Table 1. Jumper Settings (continued)

JUMPER	SHUNT POSITION	DESCRIPTION
JU5D6	1-2	Transceiver T1IN connects to Arduino/mbed connector's D6 signal
	2-3	Transceiver R1OUT connects to Arduino/mbed connector's D6 signal
	OPEN*	Arduino/mbed connector's D6 signal is not connected
JU5D7	1-2	Transceiver T1IN connects to Arduino/mbed connector's D7 signal
	2-3	Transceiver R1OUT connects to Arduino/mbed connector's D7 signal
	OPEN*	Arduino/mbed connector's D7 signal is not connected
JU5D8	1-2	Transceiver T1IN connects to Arduino/mbed connector's D8 signal
	2-3	Transceiver R1OUT connects to Arduino/mbed connector's D8 signal
	OPEN*	Arduino/mbed connector's D8 signal is not connected
JU5D9	1-2	Transceiver T1IN connects to Arduino/mbed connector's D9 signal
	2-3	Transceiver R1OUT connects to Arduino/mbed connector's D9 signal
	OPEN*	Arduino/mbed connector's D9 signal is not connected

*Default position.

Ordering Information

PART	TYPE
MAX33251ESHLD#	SHIELD

#Denotes RoHS-compliant.

MAX33251E Shield Bill of Materials

ITEM	REF_DES		QTY	MFG PART #	MANUFACTURER	VALUE	DESCRIPTION
1	C1, C2		2	C1608X5R1A106K080AC	TDK	10UF	CAPACITOR; SMT (0603); CERAMIC CHIP; 10UF; 10V; TOL = 10%; MODEL =; TG = -55°C TO +85°C; TC = X5R
2	C3-C7		5	C0603C104K8RAC	KEMET	0.1UF	CAPACITOR; SMT (0603); CERAMIC CHIP; 0.1UF; 10V; TOL = 10%; MODEL = C0603 SERIES; TG = -55°C TO +125°C; TC = X7R
3	C8		1	C0603C334K4RAC	KEMET	0.33UF	CAPACITOR; SMT (0603); CERAMIC CHIP; 0.33uF; 16V; TOL = 10%; MODEL =; TG = -55°C TO +125°C; TC = X7R
4	D1, D2		2	MBR0520L	FAIRCHILD SEMICONDUCTOR	MBR0520L	DIODE, SCHOTTKY, SOD-123, PIV = 20V, Vf = 0.385V@If = 0.5A, If(ave) = 0.5A
5	D3		1	MMSZ5231B-7-F	DIODES INCORPORATED	5.1V	DIODE; ZNR; SMT (SOD-123); VZ = 5.1V; IZ = 0.02A
6	GND A, GND B		2	5006	KEYSTONE	N/A	TEST POINT; PIN DIA = 0.125IN; TOTAL LENGTH = 0.35IN; BOARD HOLE = 0.063IN; BLACK; PHOSPHOR BRONZE WIRE SILVER PLATE FINISH;
7	J3, J6		2	SSQ-108-04-G-S	SAMTEC	SSQ-108-04-G-S	CONNECTOR; FEMALE; THROUGH HOLE; .025IN SQ POST SOCKET; STRAIGHT; 8PINS ;
8	J4		1	SSQ-106-04-G-S	SAMTEC	SSQ-106-04-G-S	CONNECTOR; FEMALE; THROUGH HOLE; .025IN SQ POST SOCKET; STRAIGHT; 6PINS ;
9	J5		1	SSQ-110-04-G-S	SAMTEC	SSQ-110-04-G-S	CONNECTOR; FEMALE; THROUGH HOLE; .025IN SQ POST SOCKET; STRAIGHT; 10PINS ;
10	JU1		1	PEC04SAAN	SULLINS ELECTRONICS CORP.	PEC04SAAN	CONNECTOR; MALE; THROUGH HOLE; BREAKAWAY; STRAIGHT; 4PINS
11	JU2, JU5D0-JU5D3, JU5D6-JU5D9		9	PEC03SAAN	SULLINS	PEC03SAAN	CONNECTOR; MALE; THROUGH HOLE; BREAKAWAY; STRAIGHT; 3PINS
12	JU3, JU4		2	PBC02SAAN	SULLINS ELECTRONICS CORP.	PBC02SAAN	EVKIT PART-CONNECTOR; MALE; THROUGH HOLE; BREAKAWAY; STRAIGHT; 2PINS; -65°C TO +125°C;
13	P1		1	182-009-213R531	NORCOMP	182-009-213R531	CONNECTOR; FEMALE; THROUGH HOLE; D-SUBMINIATURE CONNECTOR; RIGHT ANGLE; 9PINS
14	R1IN, R1OUT, T1IN, T1OUT		4	5004	KEYSTONE	N/A	TEST POINT; PIN DIA = 0.1IN; TOTAL LENGTH = 0.3IN; BOARD HOLE = 0.04IN; YELLOW; PHOSPHOR BRONZE WIRE SILVER PLATE FINISH;
15	SW1		1	MFS401N-2-Z	NIDEC COPAL ELECTRONICS CORP	MFS401N-2-Z	SWITCH; 4PDT; THROUGH HOLE; STRAIGHT; +5V TO +30V; 0.01A-0.3A; MFS SERIES; RCONTACT = 0.02Ω; RINSULATION = 100MΩ
16	T1		1	TGM-050P3RL	HALO ELECTRONICS INC	TGM-050P3RL	TRANSFORMER; SMT; 1:1:1:1; PCMCIA DC/DC CONVERTER
17	U1		1	MAX33251EELC+	MAXIM	MAX33251EELC+	EVKIT PART-IC; MAX33251E; LGA12; 6X6MM; 1MM PITCH; PACKAGE OUTLINE DRAWING: 21-100222; PACKAGE CODE: L1266M+1
18	U2		1	MAX14850AEE+	MAXIM	MAX14850AEE+	IC, ISO, SIX-CHANNEL DIGITAL ISOLATOR; QSOP16
19	U3		1	MAX845EUA+	MAXIM	MAX845EUA+	IC, DRV; ISOLATED TRANSFORMER DRIVER; UMAX8
20	VCCA_EXT, VCCB_EXT		2	5005	KEYSTONE	N/A	TEST POINT; PIN DIA=0.125IN; TOTAL LENGTH = 0.35IN; BOARD HOLE = 0.063IN; RED; PHOSPHOR BRONZE WIRE SILVER PLATE FINISH;
21	PCB		1	MAX33251E PCB	MAXIM	PCB	PCB:MAX33251ESHIELD
22	R1	DNP	0	N/A	N/A	OPEN	RESISTOR; 0603; OPEN; FORMFACTOR
23	C9	DNP	0	N/A	N/A	OPEN	CAPACITOR; SMT (0603); OPEN; FORMFACTOR
TOTAL			42				

MAX33251E Shield Schematics

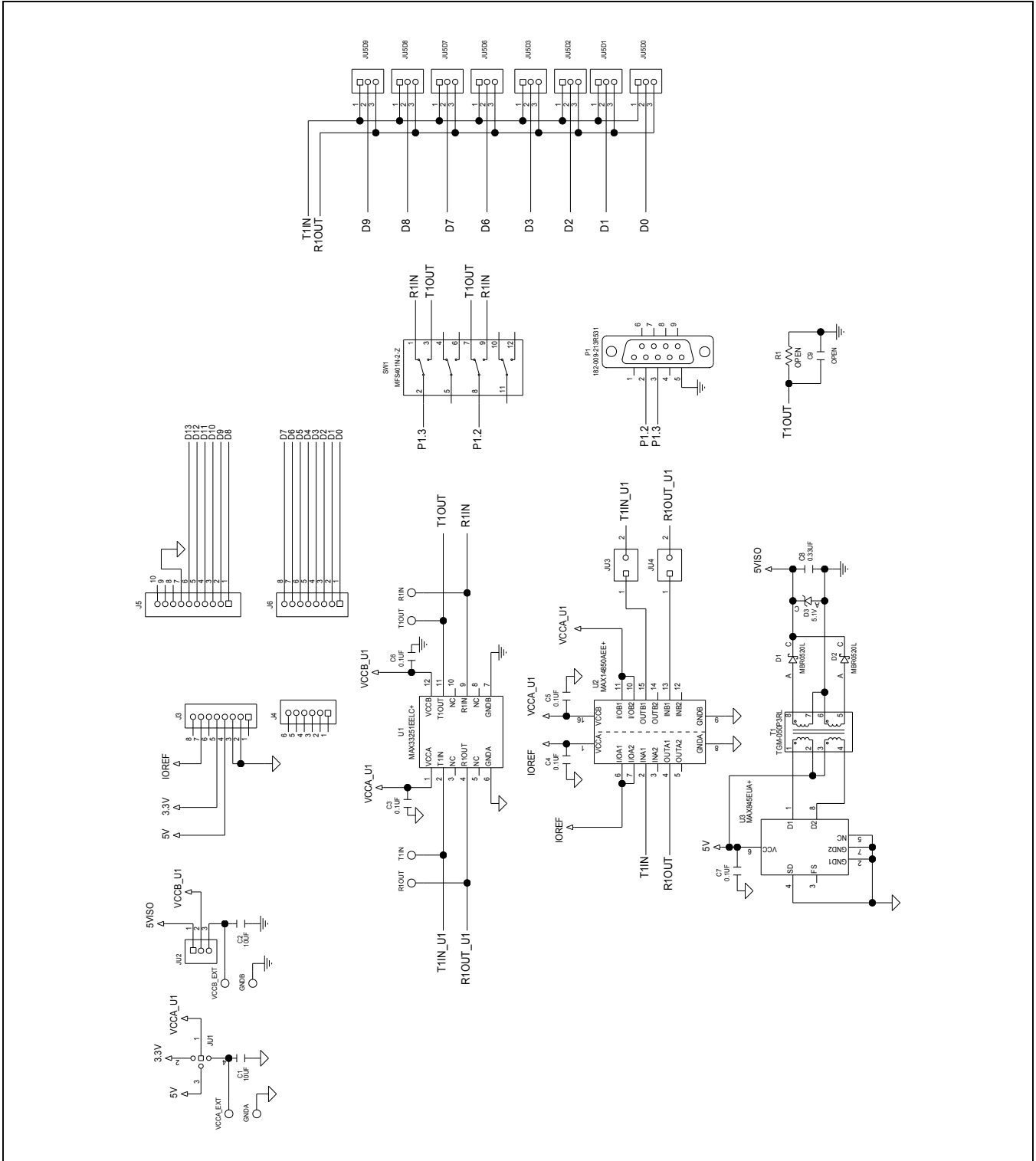

MAX33251E Shield Layout Diagrams

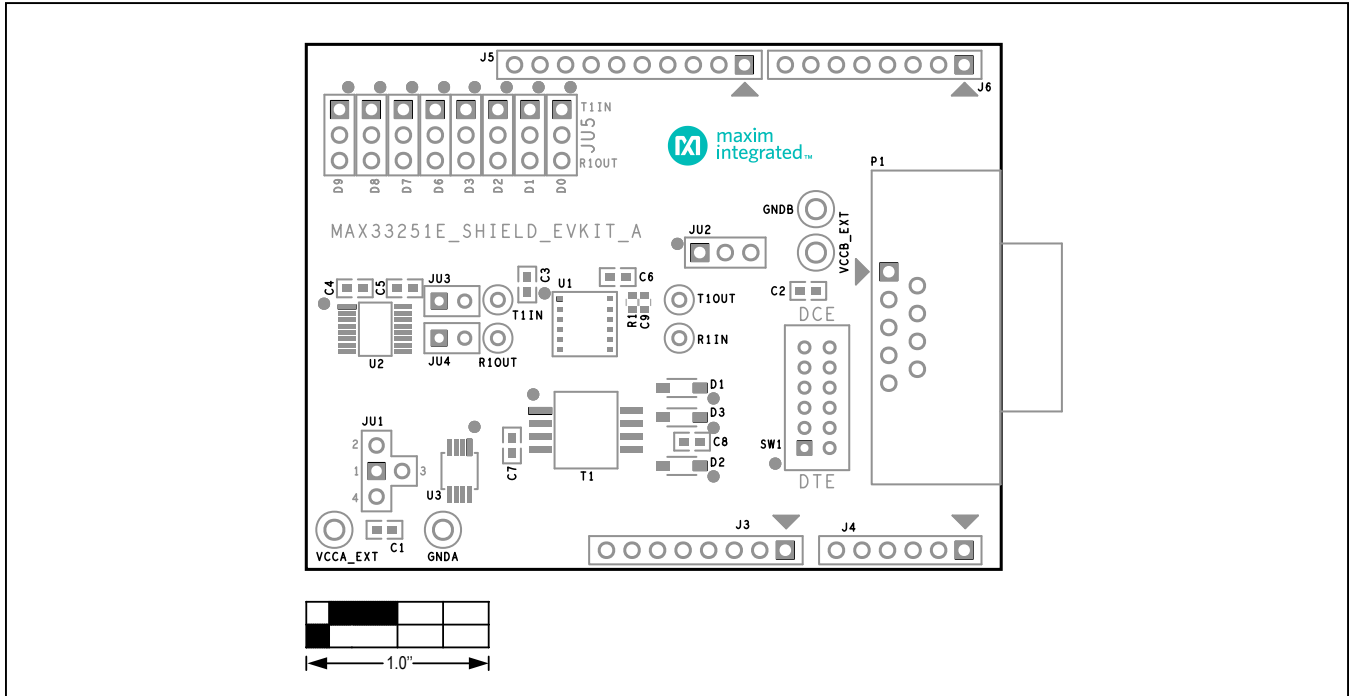

MAX33251E Shield—Top Silkscreen

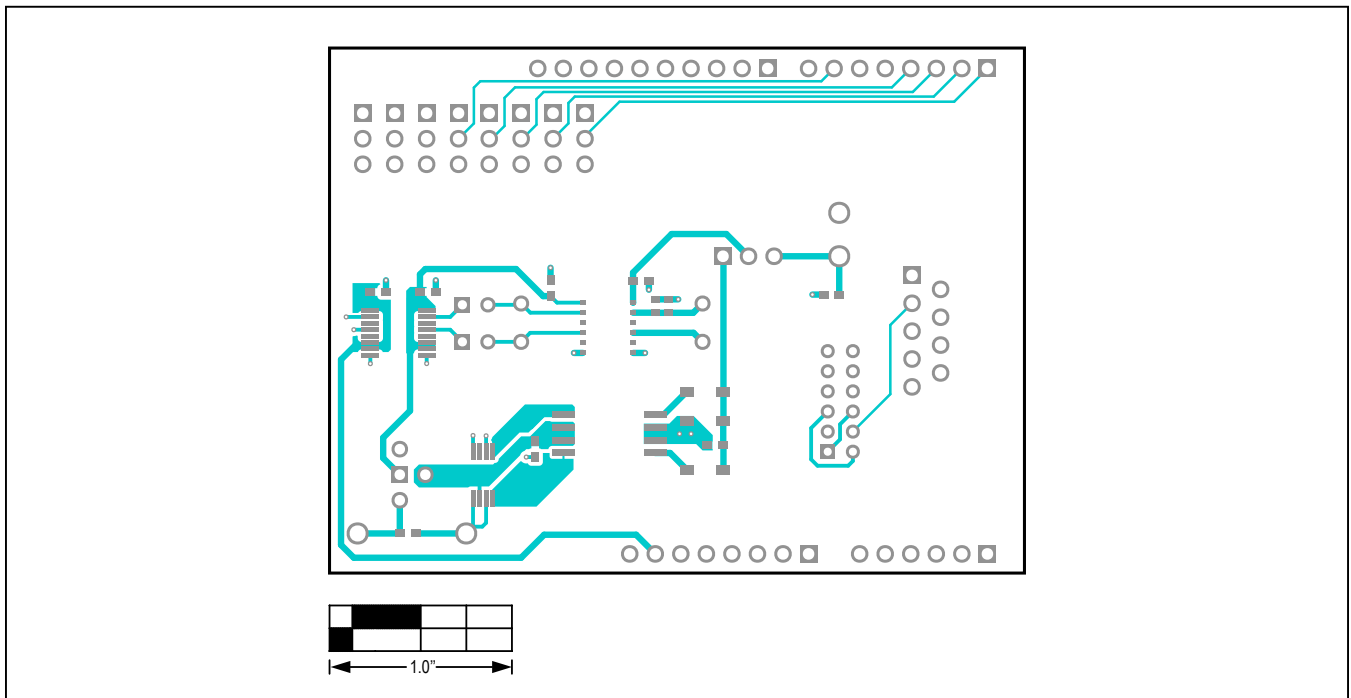

MAX33251E Shield—Top View

MAX33251E Shield Layout Diagrams (continued)

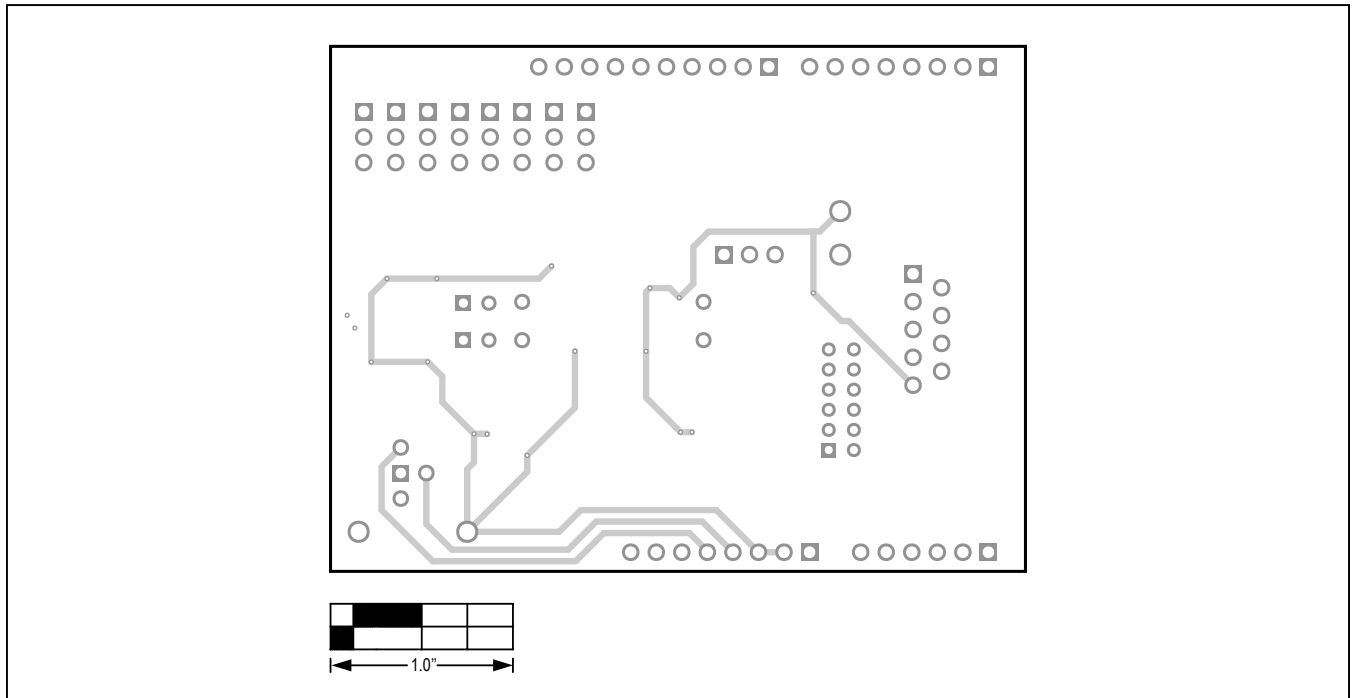

MAX33251E Shield—Internal Layer 2

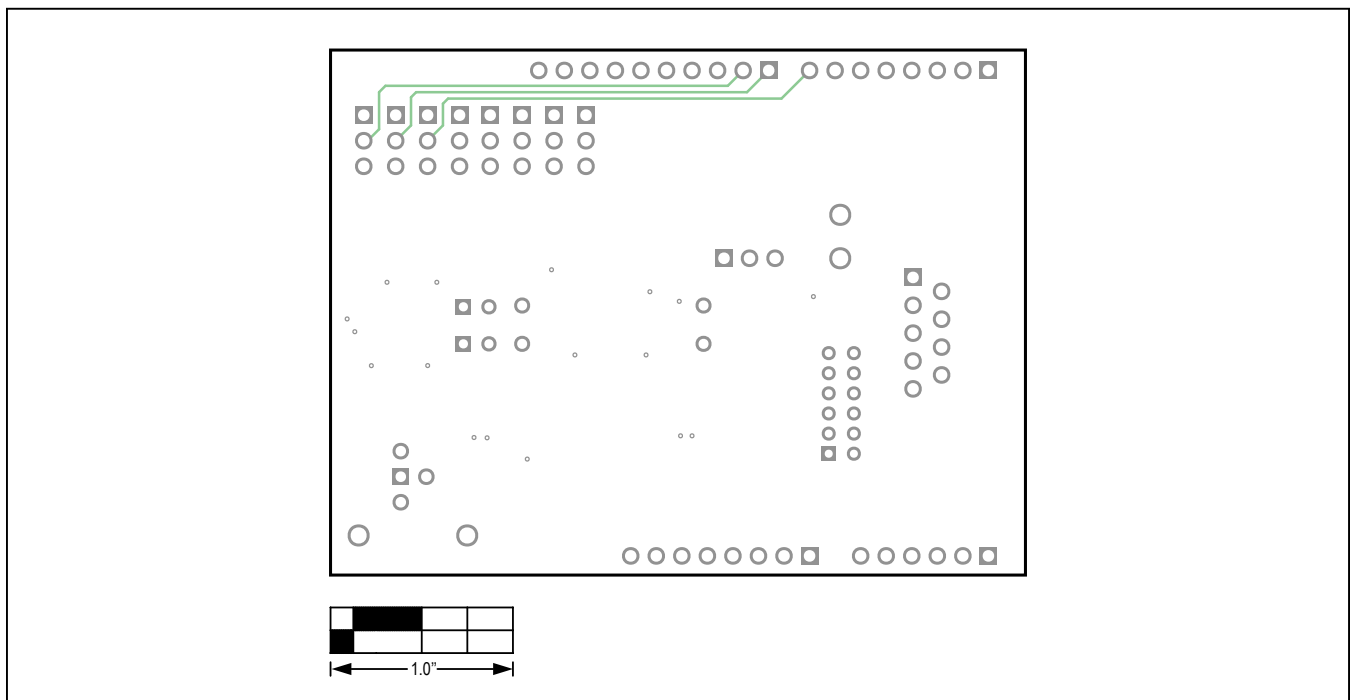

MAX33251E Shield—Internal Layer 3

MAX33251E Shield Layout Diagrams (continued)

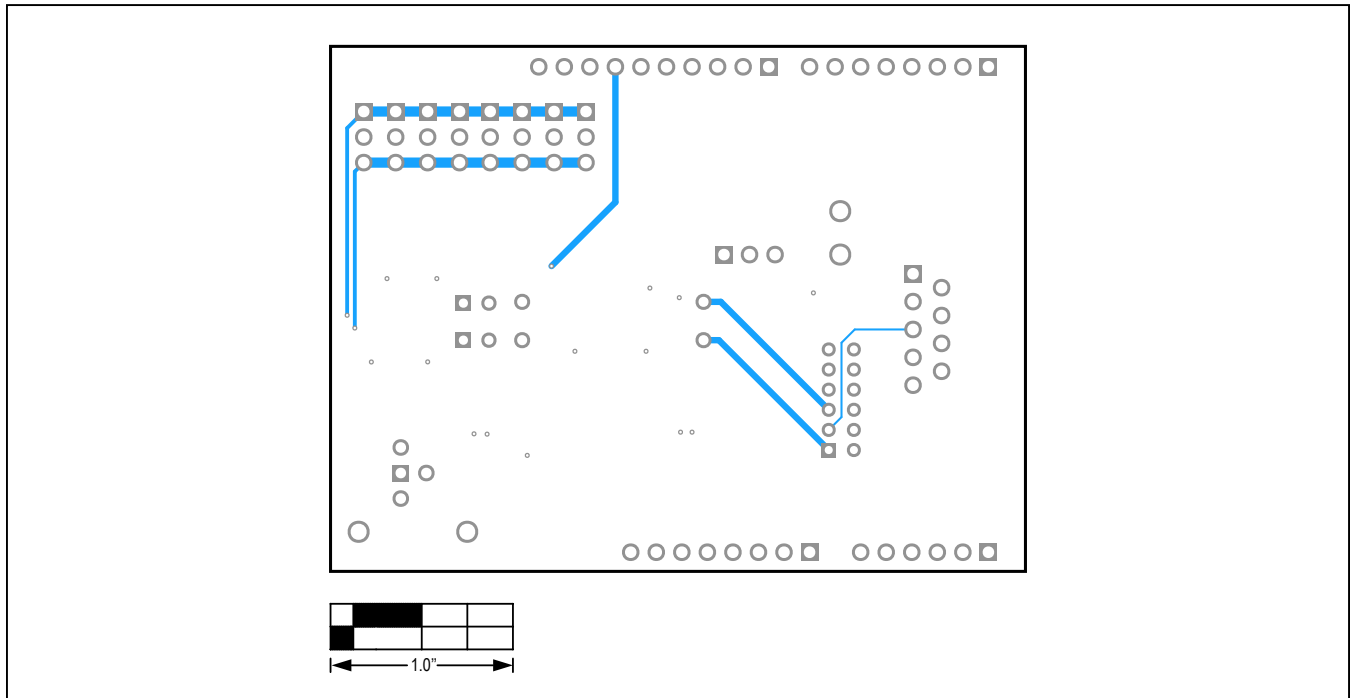

MAX33251E Shield—Bottom View

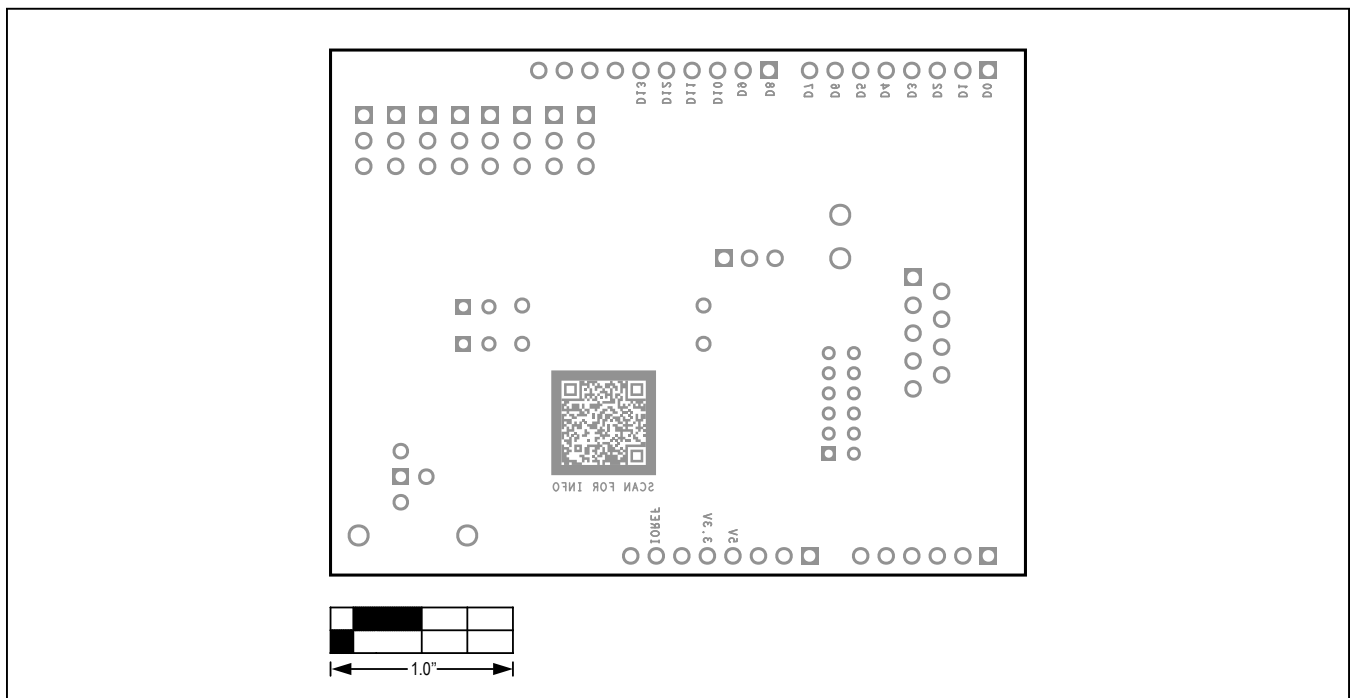

MAX33251E Shield—Silkscreen Bottom

Revision History

REVISION NUMBER	REVISION DATE	DESCRIPTION	PAGES CHANGED
0	2/19	Initial release	—

For pricing, delivery, and ordering information, please visit Maxim Integrated's online storefront at <https://www.maximintegrated.com/en/storefront/storefront.html>.

Maxim Integrated cannot assume responsibility for use of any circuitry other than circuitry entirely embodied in a Maxim Integrated product. No circuit patent licenses are implied. Maxim Integrated reserves the right to change the circuitry and specifications without notice at any time.

Компания «Океан Электроники» предлагает заключение долгосрочных отношений при поставках импортных электронных компонентов на взаимовыгодных условиях!

Наши преимущества:

- Поставка оригинальных импортных электронных компонентов напрямую с производств Америки, Европы и Азии, а так же с крупнейших складов мира;
- Широкая линейка поставок активных и пассивных импортных электронных компонентов (более 30 млн. наименований);
- Поставка сложных, дефицитных, либо снятых с производства позиций;
- Оперативные сроки поставки под заказ (от 5 рабочих дней);
- Экспресс доставка в любую точку России;
- Помощь Конструкторского Отдела и консультации квалифицированных инженеров;
- Техническая поддержка проекта, помощь в подборе аналогов, поставка прототипов;
- Поставка электронных компонентов под контролем ВП;
- Система менеджмента качества сертифицирована по Международному стандарту ISO 9001;
- При необходимости вся продукция военного и аэрокосмического назначения проходит испытания и сертификацию в лаборатории (по согласованию с заказчиком);
- Поставка специализированных компонентов военного и аэрокосмического уровня качества (Xilinx, Altera, Analog Devices, Intersil, Interpoint, Microsemi, Actel, Aeroflex, Peregrine, VPT, Syfer, Eurofarad, Texas Instruments, MS Kennedy, Miteq, Cobham, E2V, MA-COM, Hittite, Mini-Circuits, General Dynamics и др.);

Компания «Океан Электроники» является официальным дистрибьютором и эксклюзивным представителем в России одного из крупнейших производителей разъемов военного и аэрокосмического назначения «JONHON», а так же официальным дистрибьютором и эксклюзивным представителем в России производителя высокотехнологичных и надежных решений для передачи СВЧ сигналов «FORSTAR».



JONHON

«JONHON» (основан в 1970 г.)

Разъемы специального, военного и аэрокосмического назначения:

(Применяются в военной, авиационной, аэрокосмической, морской, железнодорожной, горно- и нефтедобывающей отраслях промышленности)

«FORSTAR» (основан в 1998 г.)

ВЧ соединители, коаксиальные кабели, кабельные сборки и микроволновые компоненты:

(Применяются в телекоммуникациях гражданского и специального назначения, в средствах связи, РЛС, а так же военной, авиационной и аэрокосмической отраслях промышленности).



Телефон: 8 (812) 309-75-97 (многоканальный)

Факс: 8 (812) 320-03-32

Электронная почта: ocean@oceanchips.ru

Web: <http://oceanchips.ru/>

Адрес: 198099, г. Санкт-Петербург, ул. Калинина, д. 2, корп. 4, лит. А