

TLE9278BQX V33

Multi-CAN Power+ System Basis Chip



RoHS



1 Overview

Features

- SMPS with integrated switches up to 750 mA (DC/DC buck) with 3.3 V output voltage
- DC/DC Boost converter for low V_{sup} supply voltage with integrated switch at 6.5 V, 8 V, 10 V and 12 V
- Low-Drop Voltage Regulator with external PNP device with configurable 5.0 V, 3.3 V, 1.8 V and 1.2 V output voltage, protected for off-board usage
- Very low quiescent current consumption in Stop and Sleep Mode
- Four CAN Transceivers compliant to CAN Flexible Data-rate (FD)
- ISO 11898-2: 2016 standard up to 5 Mb
- One universal High-Voltage Wake Input for voltage level monitoring including wake up capability
- Cyclic wake feature via an integrated timer
- Reset Output to ensure stable supply to the MCU
- Fail Output to activate external load in case of system malfunctions are detected
- Output voltage supervision functions in all output supply voltages
- Fast Battery Voltage Monitoring Feature
- 16-bit Serial Peripheral Interface (SPI)
- Overtemperature and short circuit protection feature
- Wide input voltage and temperature range
- Software Compatibility to other SBC family members for the TLE926x and TLE927x families
- Green Product (RoHS compliant) & AEC Qualified
- 7 × 7 mm PG-VQFN-48 package

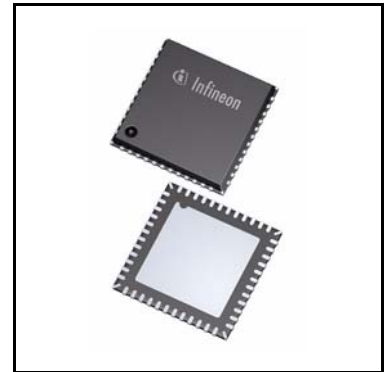

Potential applications

- Gateways
- Body control modules
- Driver assistance
- Chassis control

Overview

Product validation

Qualified for automotive applications. Product validation according to AEC-Q100/101.

Description

Infineon's TLE9278BQX V33 offers the highest level of integration at smallest footprint for automotive applications requiring multiple channels of CAN transceivers like gateways and high-end Body Control Modules (BCM). A high-efficient Switch Mode Power Supply (SMPS) buck regulator provides an external 3.3 V output voltage at up to 750 mA while an additional DC/DC boost converter supports applications or conditions at low supply input voltages. The device is controlled and monitored via a 16-bit Serial Peripheral Interface (SPI). Additional features include a time-out/window watchdog circuit with reset, fail output and undervoltage reset. The device offers low-power modes in order to support applications that are connected permanently to the battery. A wake-up from the low-power mode is possible via a message on the buses, via the bi-level sensitive monitoring/wake-up input as well as via the timer. The TLE9278BQX V33 is offered in a very small footprint, exposed pad PG-VQFN-48 (7 × 7 mm) power package.

Type	Package	Marking
TLE9278BQX V33	PG-VQFN-48	TLE9278BQXV33

Table of Contents

1	Overview	1
	Features	1
	Potential applications	1
	Product validation	2
	Description	2
	Table of Contents	3
2	Block Diagram	6
3	Pin Configuration	7
3.1	Pin Assignment	7
3.2	Pin Definitions and Functions	8
3.3	Unused Pins	10
4	General Product Characteristics	11
4.1	Absolute Maximum Ratings	11
4.2	Functional Range	13
4.3	Thermal Resistance	14
4.4	Current Consumption	14
5	System Features	17
5.1	State Machine Description and SBC Mode Control	17
5.1.1	Device Configuration and SBC Init Mode	20
5.1.1.1	Supply and Power up configurability	20
5.1.1.2	Watchdog trigger failure configuration	20
5.1.1.3	SBC Init Mode	22
5.1.2	SBC Normal Mode	23
5.1.3	SBC Stop Mode	23
5.1.4	SBC Sleep Mode	23
5.1.5	SBC Restart Mode	24
5.1.6	SBC Fail-Safe Mode	25
5.1.7	SBC Development Mode	26
5.2	Wake Features	27
5.2.1	Cyclic Wake	27
5.2.2	Internal Timer	27
6	DC/DC Regulator	28
6.1	Block Description	28
6.1.1	Functional Description of the Buck Converter	29
6.1.1.1	Startup Procedure (Soft Start)	30
6.1.1.2	Buck regulator Status register	30
6.1.1.3	External components	30
6.1.2	Functional Description of the Boost Converter	31
6.1.2.1	Boost Regulator Status register	32
6.1.2.2	External Components	32
6.2	Power Scenarios	33
6.2.1	Buck behavior in SBC Normal Mode	33
6.2.2	Buck behavior in SBC Stop Mode	33

6.2.2.1	Automatic Transition from PFM to PWM in SBC Stop Mode	33
6.2.2.2	Manual Transition from PFM to PWM in SBC Stop Mode	34
6.2.2.3	SBC Stop to Normal Mode transition	34
6.2.3	Buck behavior in SBC Sleep or Fail Safe Mode	34
6.2.3.1	SBC Sleep/Fail Safe Mode to SBC Normal Mode transition	34
6.3	Electrical Characteristics	35
7	External Voltage Regulator	38
7.1	Block Description	38
7.2	General Description	39
7.2.1	Functional Description	39
7.3	External Components	40
7.4	Calculation of R_{SHUNT}	41
7.5	Unused Pins	41
7.6	Electrical Characteristics	42
8	High Speed CAN Transceiver	44
8.1	Block Description	44
8.2	Functional Description	44
8.2.1	CAN OFF Mode	46
8.2.2	CAN Normal Mode	46
8.2.3	CAN Receive Only Mode	46
8.2.4	CAN Wake Capable Mode	47
8.2.5	TXD Time-out Feature	48
8.2.6	Bus Dominant Clamping	48
8.2.7	Undervoltage Detection	48
8.3	Electrical Characteristics	49
9	Wake Input	56
9.1	Features	56
9.2	Functional Description	56
9.2.1	Wake Input Configuration	57
9.3	Electrical Characteristics	59
10	Interrupt Function	60
10.1	Block and Functional Description	60
10.2	Electrical Characteristics	62
11	Fail Output	63
11.1	Functional Description	63
11.2	Electrical Characteristics	65
12	Supervision Functions	66
12.1	Reset Function	66
12.1.1	Reset Output Description	66
12.1.2	Soft Reset Description	67
12.2	Watchdog	67
12.2.1	Time-Out Watchdog	68
12.2.2	Window Watchdog	69
12.2.3	Checksum	69
12.2.4	Watchdog during Stop Mode	70

12.2.4.1	Watchdog Start in SBC Stop Mode due to BUS Wake	70
12.3	V _S Power ON Reset	71
12.4	Measurement Interface	72
12.5	Fast Battery Voltage Monitoring	73
12.6	VBSense Boost deactivation	73
12.7	VIO Undervoltage and Undervoltage Prewarning	74
12.8	VIO Overvoltage	74
12.9	VIO Short Circuit	75
12.10	VEXT Undervoltage	75
12.11	Thermal Protection	75
12.11.1	Temperature Prewarning	76
12.12	Electrical Characteristics	77
13	Serial Peripheral Interface	81
13.1	SPI Protocol Description	81
13.2	Failure Signalization in the SPI Data Output	82
13.3	SPI Programming	84
13.4	SPI Bit Mapping	86
13.4.1	SPI Mapping Structure	86
13.4.2	SPI Mapping Tables	87
13.5	SPI Control Registers	89
13.5.1	General Control Registers	90
13.6	SPI Status Information Registers	103
13.6.1	General Status Registers	104
13.6.2	Family and Product Information Register	116
13.7	Electrical Characteristics	117
14	Application Information	119
14.1	Application Diagram	119
14.2	ESD Tests	122
14.3	Thermal Behavior of Package	123
15	Package Outlines	124
16	Revision History	125

Block Diagram

2 Block Diagram

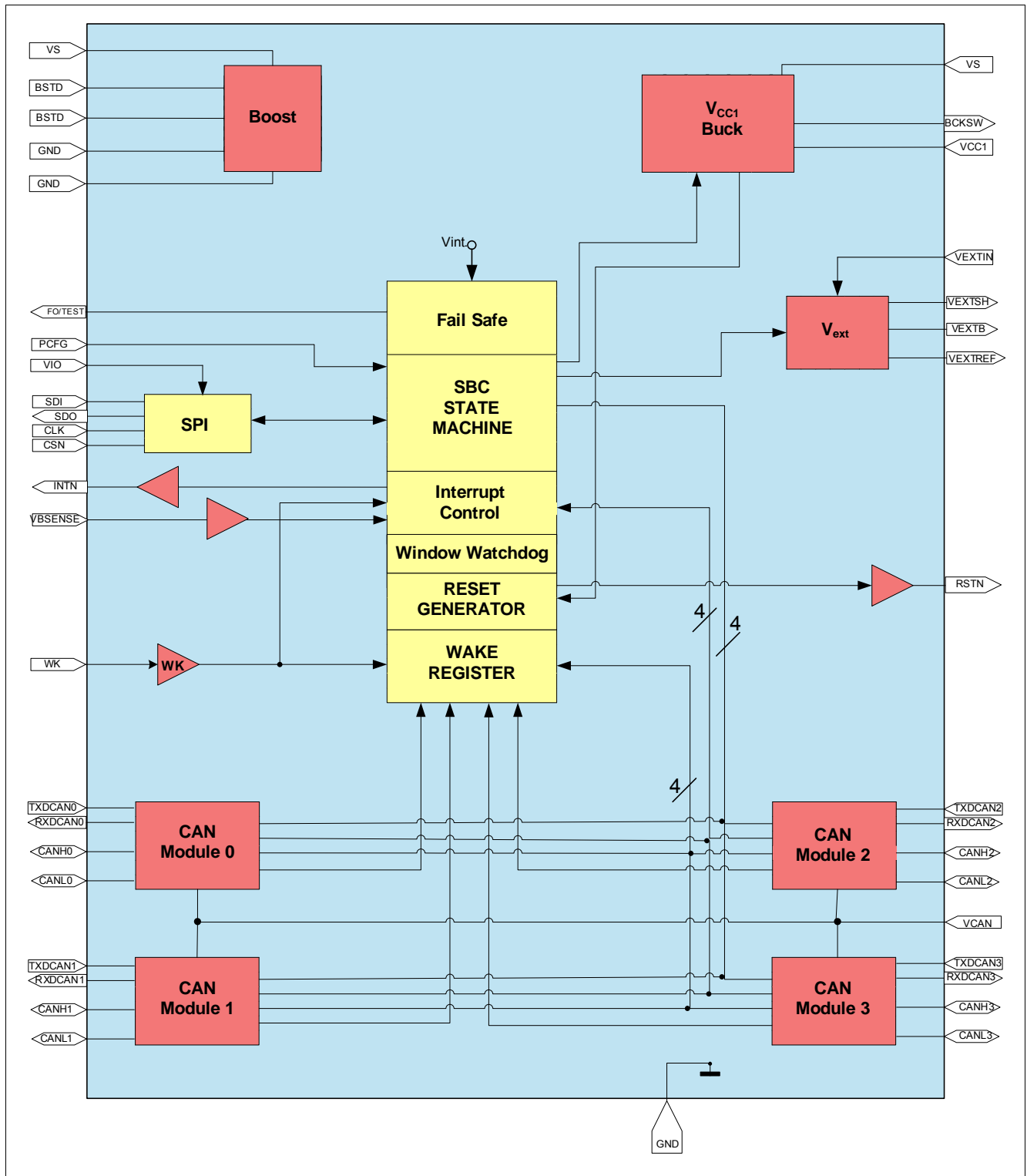

Figure 1 Block Diagram

Pin Configuration

3 Pin Configuration

3.1 Pin Assignment

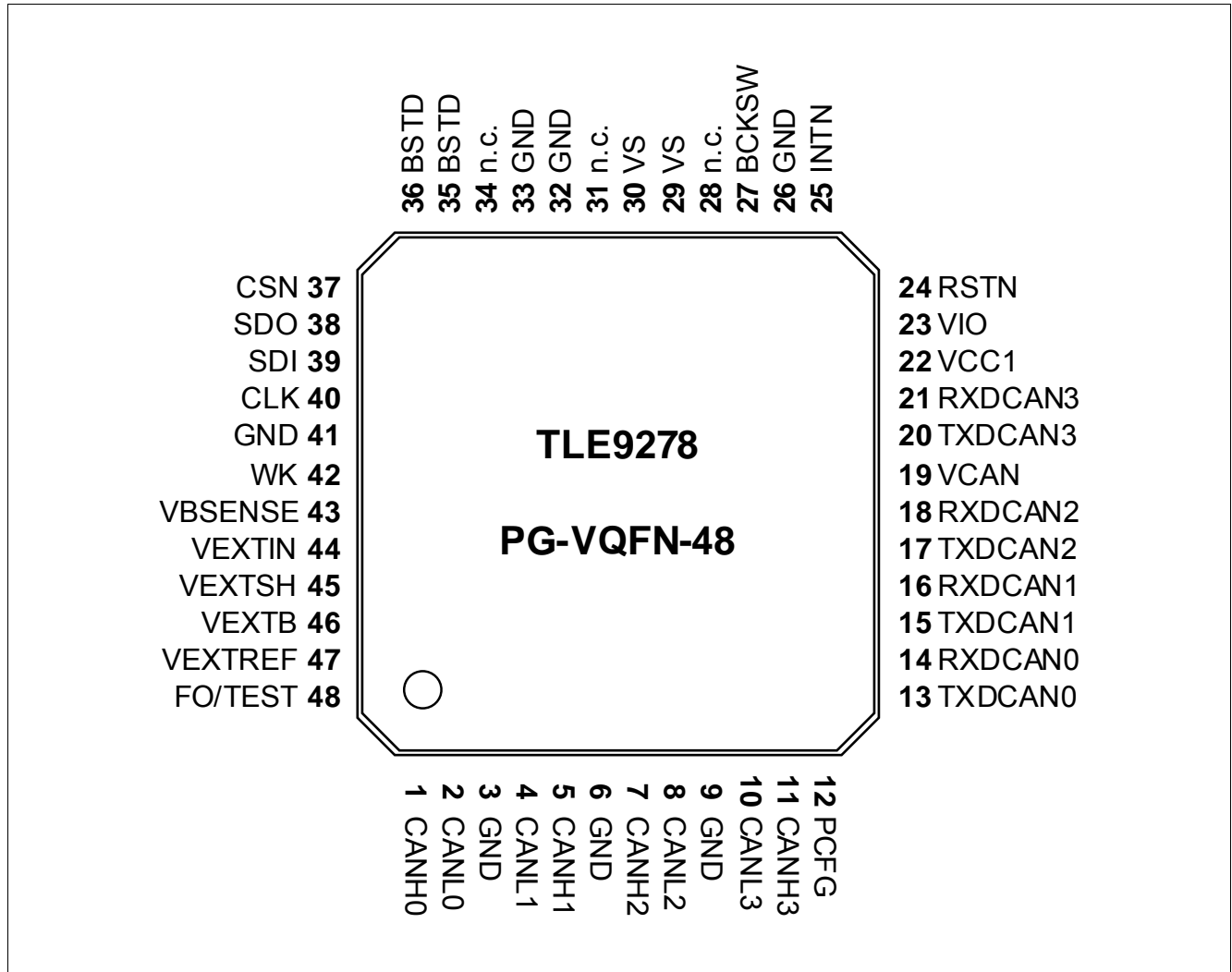

Figure 2 Pin Configuration TLE9278BQX V33

Pin Configuration

3.2 Pin Definitions and Functions

Pin	Symbol	Function
1	CANH0	CAN High 0 Bus Pin.
2	CANL0	CAN Low 0 Bus Pin.
3	GND	Ground. CAN0 and CAN1 common ground.
4	CANL1	CAN Low 1 Bus Pin.
5	CANH1	CAN High 1 Bus Pin.
6	GND	Ground. Analog GND.
7	CANH2	CAN High 2 Bus Pin.
8	CANL2	CAN Low 2 Bus Pin.
9	GND	Ground. CAN2 and CAN3 common ground.
10	CANL3	CAN Low 3 Bus Pin.
11	CANH3	CAN High 3 Bus Pin.
12	PCFG	Configuration pin. For power up hardware configuration (refer to Chapter 5.1.1).
13	TXDCAN0	Transmit CAN0.
14	RXDCAN0	Receive CAN0.
15	TXDCAN1	Transmit CAN1.
16	RXDCAN1	Receive CAN1.
17	TXDCAN2	Transmit CAN2.
18	RXDCAN2	Receive CAN2.
19	VCAN	Supply Input for internal HS-CAN modules.
20	TXDCAN3	Transmit CAN3.
21	RXDCAN3	Receive CAN3.
22	VCC1	Buck Regulator. Input feedback for Buck Converter.
23	VIO	I/O voltage supply, reference voltage for over-/undervoltage monitoring (see Chapter 5.1.1).
24	RSTN	Reset Output. Active LOW, internal pull-up.
25	INTN	Interrupt Output. Active LOW.
26	GND	Ground. Buck regulator ground.
27	BCKSW	Buck regulator switch node output.
28	n.c.	not connected. Not bonded internally.
29	VS	Buck Supply Voltage. Connected to Battery Voltage or Boost output voltage with reverse protection diode. Use a filter against EMC in case that the Boost is not used.
30	VS	Buck Supply Voltage. Connected to Battery Voltage or Boost output voltage with reverse protection diode. Use a filter against EMC in case that the Boost is not used.
31	n.c.	not connected. Not bonded internally.
32	GND	Ground. Boost regulator ground.
33	GND	Ground. Boost regulator ground.

Pin Configuration

Pin	Symbol	Function
34	n.c.	not connected. Not bonded internally.
35	BSTD	Boost Transistor Drain. Connected between inductor and diode for boost functionality (refer to Chapter 14.1 for additional information). Connect to ground if the Boost regulator is not used.
36	BSTD	Boost Transistor Drain. Connected between inductor and diode for boost functionality (refer to Chapter 14.1 for additional information). Connect to ground if the Boost regulator is not used.
37	CSN	SPI Chip Select Not Input.
38	SDO	SPI Data Output. Out of SBC (=MISO).
39	SDI	SPI Data Input. Into SBC (=MOSI).
40	CLK	SPI Clock Input.
41	GND	Ground. Common digital ground.
42	WK	Wake Input.
43	VBSENSE	Battery Voltage Monitoring Input.
44	VEXTIN	Input Supply Voltage for VEXT. Connected to Battery Voltage with Reverse Protection Diode and Filter against EMC.
45	VEXTSH	VEXTSH. Emitter connection for external PNP, shunt connection to VEXTIN.
46	VEXTB	VEXTB. Base connection for external PNP.
47	VEXTREF	VextREF. Collector connection for external PNP, reference input.
48	FO/TEST	Fail Output. active LOW, open-drain; TEST. Connect to GND to activate SBC Software Development Mode; Integrated pull-up resistor. Connect to VS with a pull-up resistor or leave open for normal operation.
Cooling Tab	GND	Cooling Tab - Exposed Die Pad; For cooling purposes only, do not use as an electrical ground. ¹⁾

1) The exposed die pad at the bottom of the package allows better power dissipation of heat from the SBC via the PCB. The exposed die pad is not connected to any active part of the IC and can be left floating or it can be connected to GND (recommended) for the best EMC performance.

Note: All VS pins must be connected to battery potential or insert a reverse polarity diodes where required; All GND pins as well as the Cooling Tab must be connected to one common GND potential.

Pin Configuration

3.3 Unused Pins

It must be ensured that the correct configurations are also selected, i.e. in case functions are not used that they are disabled via SPI:

- CANHx, CANLx, TXDCANx, RXDCANx: leave pins open.
- BSTD: connect to GND.
- WK: connect to GND and disable WK input via SPI.
- RSTN / INTN: leave open.
- FO/TEST: connect to GND during power-up to activate SBC Development Mode; connect to VS or leave open for normal user mode operation.
- VBSENSE: connect to VS in case that Fast Battery Voltage Monitoring and Boost deactivation features are not used and keep them disabled.
- VEXT: See [Chapter 7.5](#).
- n.c.: leave open.
- Unused pins routed to an external connector which leaves the ECU should feature a zero ohm jumper (depopulated if unused) or ESD protection.

General Product Characteristics

4 General Product Characteristics

4.1 Absolute Maximum Ratings

Table 1 Absolute Maximum Ratings¹⁾

$T_j = -40^\circ\text{C}$ to $+150^\circ\text{C}$; all voltages with respect to ground, positive current flowing into pin (unless otherwise specified)

Parameter	Symbol	Values			Unit	Note or Test Condition	Number
		Min.	Typ.	Max.			
Voltages							
Supply Voltage VS and VEXTIN pin	$V_{S1, \max}$	-0.3	-	28	V	-	P_4.1.1
Supply Voltage VS and VEXTIN pin	$V_{S2, \max}$	-0.3	-	40	V	Load Dump, max. 400 ms	P_4.1.2
Boost drain Voltage BSTD pin	$V_{BSTD2, \max}$	-0.3	-	28	V	-	P_4.1.3
Boost drain Voltage BSTD pin	$V_{BSTD2, \max}$	-0.3	-	40	V	Load Dump, max. 400 ms	P_4.1.4
Buck switch BCKSW pin	$V_{BCKSW, \max}$	-0.3	-	$V_S + 0.3$	V	-	P_4.1.8
Buck Regulator feedback, pin VCC1	$V_{CC1, \max}$	-0.3	-	5.5	V	-	P_4.1.9
External Voltage Regulator (VEXTREF)	$V_{EXTREF, \max}$	-0.3	-	28	V	$V_{EXTREF} = 40$ V for Load Dump, max. 400 ms	P_4.1.26
External Voltage Regulator (VEXTB)	$V_{EXTB, \max}$	-0.3	-	$V_{EXTIN} + 10$	V	$V_{EXTB} = 40$ V for Load Dump, max. 400 ms	P_4.1.27
External Voltage Regulator (VEXTSH)	$V_{EXTSH, \max}$	$V_{EXTIN} - 0.3$	-	$V_{EXTIN} + 0.3$	V	-	P_4.1.11
Battery Voltage Monitoring	$V_{VBSENSE, \max}$	-18	-	40	V	-	P_4.1.12
Wake Input	$V_{WK, \max}$	-0.3	-	40	V	-	P_4.1.13
Fail Pins FO/TEST	$V_{HV, \max}$	-0.3	-	40	V	-	P_4.1.14
Interrupt/Configuration Pin INTN	$V_{INTN, \max}$	-0.3	-	5.5	V	-	P_4.1.15
Configuration Pin PCFG	$V_{PCFG, \max}$	-0.3	-	40	V	-	P_4.1.25
Configuration Pin VIO	$V_{VIO, \max}$	-0.3	-	5.5	V	-	P_4.1.28
CANH, CANL	$V_{BUS, \max}$	-40	-	40	V	-	P_4.1.16
Digital Input / Output pin's	$V_{IO, \max}$	-0.3	-	5.5	V	-	P_4.1.17
VCAN Input Voltage	$V_{VCAN, \max}$	-0.3	-	5.5	V	-	P_4.1.18
Maximum Differential CAN Bus Voltage	$V_{CAN_DIFF, \max}$	-5	-	10	V	-	P_4.1.30

General Product Characteristics

Table 1 Absolute Maximum Ratings¹⁾ (cont'd)

$T_j = -40^\circ\text{C}$ to $+150^\circ\text{C}$; all voltages with respect to ground, positive current flowing into pin (unless otherwise specified)

Parameter	Symbol	Values			Unit	Note or Test Condition	Number
		Min.	Typ.	Max.			
Temperatures							
Junction Temperature	T_j	-40	-	150	$^\circ\text{C}$	-	P_4.1.19
Storage Temperature	T_{stg}	-55	-	150	$^\circ\text{C}$	-	P_4.1.20
ESD Susceptibility							
ESD Resistivity to GND	V_{ESD}	-2	-	2	kV	HBM ²⁾	P_4.1.21
ESD Resistivity to GND, CANH, CANL	V_{ESD}	-8	-	8	kV	HBM ²⁾³⁾	P_4.1.22
ESD Resistivity to GND	V_{ESD}	-500	-	500	V	CDM ⁴⁾	P_4.1.23
ESD Resistivity Pin 1, 12,13,24,25,36,37,48 (corner pins) to GND	$V_{\text{ESD1,12,13,24,25,36,37,48}}$	-750	-	750	V	CDM ⁴⁾	P_4.1.24

- 1) Not subject to production test, specified by design.
- 2) ESD susceptibility, HBM according to ANSI/ESDA/JEDEC JS-001 (1.5 k Ω , 100 pF).
- 3) ESD "GUN" Resistivity with ± 6 kV (according to IEC61000-4-2 "GUN test" (300 Ω , 150 pF)) it is shown in Application Information and test will be provided from IBEE institute.
- 4) ESD susceptibility, Charged Device Model "CDM" EIA/JESD22-C101 or ESDA STM5.3.1, usually not tested but rather ESD SDM.

Notes

1. Stresses above the ones listed here may cause permanent damage to the device. Exposure to absolute maximum rating conditions for extended periods may affect device reliability.
2. Integrated protection functions are designed to prevent IC destruction under fault conditions described in the data sheet. Fault conditions are considered as "outside" normal operating range. Protection functions are not designed for continuous repetitive operation.

General Product Characteristics

4.2 Functional Range

Table 2 Functional Range

Parameter	Symbol	Values			Unit	Note or Test Condition	Number
		Min.	Typ.	Max.			
Supply Voltage	$V_{S,func}$	V_{POR}	–	28	V	¹⁾ V_{POR} see section Chapter 12.12	P_4.2.1
CANx Supply Voltage	V_{CAN}	4.75	–	5.25	V	–	P_4.2.2
SPI frequency	f_{SPI}	–	–	4	MHz	see Chapter 13.7 for $f_{SPI,max}$	P_4.2.3
Junction Temperature	T_j	-40	–	150	°C	–	P_4.2.4

1) Including Power-On Reset, Over- and Undervoltage Protection.

Note: Within the functional range the IC operates as described in the circuit description. The electrical characteristics are specified within the conditions given in the related electrical characteristics table.

Device Behavior Outside of Specified Functional Range:

- $28\text{ V} < V_{S,func} < 40\text{ V}$: Device will still be functional; the specified electrical characteristics might not be ensured anymore. The absolute maximum ratings are not violated. However, a thermal shutdown might occur due to high power dissipation.
- $V_{CAN} < 4.75\text{ V}$: The undervoltage bit **VCAN_UV** will be set in the SPI register **BUS_STAT_0** and the transmitter will be disabled as long as the UV condition is present.
- $5.25\text{ V} < V_{CAN} < 5.5\text{ V}$: CANx transceiver still functional. However, the communication might fail due to out-of-spec operation.
- $V_{POR,f} < V_S < 5.5\text{ V}$: Device will be still functional; the specified electrical characteristics might not be ensured anymore:
 - The voltage regulators will enter the low-drop operation mode.
 - **VIO_UV** reset could be triggered depending on the VRTx settings.

General Product Characteristics

4.3 Thermal Resistance

Table 3 Thermal Resistance¹⁾

Parameter	Symbol	Values			Unit	Note or Test Condition	Number
		Min.	Typ.	Max.			
Junction to Soldering Point	R_{thJSP}	–	7	–	K/W	Exposed Pad	P_4.3.1
Junction to Ambient	R_{thJA}	–	33	–	K/W	²⁾	P_4.3.2

1) Not subject to production test, specified by design.

2) According to Jedec JESD51-2,-5,-7 at natural convection on FR4 2s2p board for 1.5 W. Board: 76.2 × 114.3 × 1.5 mm³ with 2 inner copper layers (35 μm thick), with thermal via array under the exposed pad. Top and bottom layers are 70 μm thick.

4.4 Current Consumption

Table 4 Current Consumption

Current consumption values are specified at $T_j = 25^\circ\text{C}$, $V_S = 13.5\text{ V}$, all outputs open (unless otherwise specified)

Parameter	Symbol	Values			Unit	Note or Test Condition	Number
		Min.	Typ.	Max.			
SBC Normal Mode							
Normal Mode current consumption	I_{Normal}	–	10	16	mA	$V_S = 5.5\text{ V to }28\text{ V}$; $T_j = -40^\circ\text{C to }+150^\circ\text{C}$; BOOST/VEXT/CANx = OFF	P_4.4.1
SBC Stop Mode							
Stop Mode current Consumption	$I_{Stop,25}$	–	55	70	μA	¹⁾ Buck in PFM BOOST/VEXT = OFF; No load on VCC1 VBSENSE_EN = 0 _B CANx/WK not wake capable Watchdog = OFF	P_4.4.2
Stop Mode current Consumption, $T_j = 85^\circ\text{C}$	$I_{Stop,85}$	–	95	–	μA	²⁾ $T_j = 85^\circ\text{C}$; Buck in PFM BOOST/VEXT = OFF; No load on VCC1 VBSENSE_EN = 0 _B CANx/WK not wake capable Watchdog = OFF	P_4.4.3
SBC Sleep Mode							
Sleep Mode current consumption	$I_{Sleep,25}$	–	30	50	μA	BOOST/VEXT = OFF; VBSENSE_EN = 0 _B CANx/WK not wake capable	P_4.4.4

General Product Characteristics

Table 4 Current Consumption (cont'd)

Current consumption values are specified at $T_j = 25^\circ\text{C}$, $V_S = 13.5\text{ V}$, all outputs open (unless otherwise specified)

Parameter	Symbol	Values			Unit	Note or Test Condition	Number
		Min.	Typ.	Max.			
Sleep Mode current consumption, $T_j = 85^\circ\text{C}$	$I_{\text{Sleep},85}$	–	65	–	μA	²⁾ $T_j = 85^\circ\text{C}$; BOOST/VEXT = OFF; VBSENSE_EN = 0 _B CANx/WK not wake capable	P_4.4.5

Feature Incremental Current Consumption

Current consumption per CAN module, recessive state	$I_{\text{CAN,rec}}$	–	2	3	mA	SBC Normal Mode; CAN Normal Mode; $V_{\text{CAN}} = 5\text{ V}$; $V_{\text{TXDCAN}} = V_{\text{IO}}$; no RL on CANx	P_4.4.6
Current consumption per CAN module, dominant state	$I_{\text{CAN,dom}}$	–	3	4.5	mA	²⁾ SBC Normal Mode; CAN Normal Mode; $V_{\text{CAN}} = 5\text{ V}$; $V_{\text{TXDCAN}} = \text{GND}$; no RL on CANx	P_4.4.7
Current consumption per CAN module, Receive Only Mode, SBC Normal Mode	$I_{\text{CAN,RcvOnly,NM}}$	–	0.4	0.6	mA	²⁾ CAN Receive Only Mode; $V_{\text{CAN}} = 5\text{ V}$; $V_{\text{TXDCAN}} = V_{\text{IO}}$; no RL on CANx	P_4.4.8
Current consumption per CAN module, Receive Only Mode, SBC Stop Mode	$I_{\text{CAN,RcvOnly,StM}}$	–	1	1.4	mA	²⁾ CAN Receive Only Mode; $V_{\text{CAN}} = 5\text{ V}$; $V_{\text{TXDCAN}} = V_{\text{IO}}$; no RL on CANx	P_4.4.25
Current consumption for WK wake capability	$I_{\text{Wake,WK},25}$	–	0.5	1.5	μA	³⁾⁴⁾ SBC Sleep Mode; CANx = OFF	P_4.4.11
Current consumption for WK wake capability $T_j = 85^\circ\text{C}$	$I_{\text{Wake,WK},85}$	–	2.0	4.0	μA	²⁾³⁾⁴⁾ SBC Sleep Mode; $T_j = 85^\circ\text{C}$; CANx = OFF	P_4.4.12
Current consumption for CAN wake capability	$I_{\text{Wake,CAN},25}$	–	4.5	6	μA	¹⁾³⁾ SBC Sleep Mode; WK = OFF t_{SILENCE} expired	P_4.4.13
Current consumption for CAN wake capability	$I_{\text{Wake,CAN},85}$	–	6	10	μA	¹⁾²⁾³⁾ SBC Sleep Mode; $T_j = 85^\circ\text{C}$; WK = OFF t_{SILENCE} expired	P_4.4.14
Current consumption for VEXT in SBC Sleep Mode	$I_{\text{Sleep,VEXT},25}$	–	45	60	μA	³⁾ SBC Sleep Mode; VEXT = ON (no load); CANx / WK = OFF	P_4.4.15

General Product Characteristics

Table 4 Current Consumption (cont'd)

Current consumption values are specified at $T_j = 25^\circ\text{C}$, $V_S = 13.5\text{ V}$, all outputs open (unless otherwise specified)

Parameter	Symbol	Values			Unit	Note or Test Condition	Number
		Min.	Typ.	Max.			
Current consumption for VEXT in SBC Sleep Mode, $T_j = 85^\circ\text{C}$	$I_{\text{Sleep,VEXT,85}}$	–	55	70	μA	²⁾³⁾ SBC Sleep Mode; $T_j = 85^\circ\text{C}$; VEXT = ON (no load); CANx / WK = OFF	P_4.4.16
Current consumption for cyclic wake function	$I_{\text{Stop,C25}}$	–	20	26	μA	³⁾⁵⁾ SBC Stop Mode; WD = OFF	P_4.4.17
Current consumption for cyclic wake function, $T_j = 85^\circ\text{C}$	$I_{\text{Stop,C85}}$	–	24	35	μA	²⁾³⁾⁵⁾ SBC Stop Mode; $T_j = 85^\circ\text{C}$; WD = OFF	P_4.4.18
Current consumption for watchdog active in Stop Mode	$I_{\text{Stop,WD25}}$	–	20	26	μA	²⁾ SBC Stop Mode; Watchdog running	P_4.4.19
Current consumption for watchdog active in Stop Mode	$I_{\text{Stop,WD85}}$	–	24	35	μA	²⁾ SBC Stop Mode; $T_j = 85^\circ\text{C}$; Watchdog running	P_4.4.20
Current consumption for active fail output (FO)	$I_{\text{Stop,FO}}$	–	0.5	1.5	mA	²⁾ All SBC Modes; $T_j = 25^\circ\text{C}$; FO = ON (no load);	P_4.4.21
Current consumption Fast Battery Monitoring in SBC Stop Mode	$I_{\text{Stop,FBM}}$	–	5	–	μA	²⁾ SBC Stop Modes; VBSense_EN = 1 _B ; $T_j = 25^\circ\text{C}$;	P_4.4.30
Additional V_S current consumption with Boost Module Active	$I_{\text{BOOST,ON}}$	–	10	20	mA	²⁾ SBC Normal / Stop Modes; $V_{\text{BSTx}} < V_S < V_{\text{BST,thx}}$; BOOST_EN = 1 _B ;	P_4.4.31

- 1) Current consumption for CANx transceiver and WK input to be added if set to be wake capable or receiver only.
- 2) Not subject to production test, specified by design.
- 3) Current consumption adders of features defined for SBC Sleep Mode also apply for SBC Stop Mode and vice versa (unless otherwise specified).
- 4) No pull-up or pull-down configuration selected.
- 5) Cyclic wake configuration: Timer with 20 ms period.

System Features

5 System Features

This chapter describes the system features and behavior of the TLE9278BQX V33:

- State machine and SBC mode control.
- Device configurations.
- State of supply and peripherals.
- Wake features.
- Supervision and diagnosis functions.

The System Basis Chip is controlled via a 16-bit SPI interface. A detailed description can be found in [Chapter 13](#). The configuration as well as the diagnosis is handled via the SPI. The SPI mapping of the TLE9278BQX V33 is compatible to other devices of TLE926x and TLE927x family.

The System Basis Chip (SBC) offers six operating modes:

- SBC Init Mode: power-up of the device and after soft reset.
- SBC Normal Mode: the main operating mode of the device.
- SBC Stop Mode: the first-level power saving mode with the main voltage regulator enabled.
- SBC Sleep Mode: the second-level power saving mode with Buck regulator disable.
- SBC Restart Mode: an intermediate mode after a wake event from SBC Sleep or SBC Fail-Safe Mode or after a failure (e.g. WD failure in config 1/3) to bring the microcontroller into a defined state via a reset. Once the failure condition is not present anymore, the device will automatically change to SBC Normal Mode after a delay time (t_{RD1}).
- SBC Fail-Safe Mode: a safe-state mode after critical failures (e.g. TSD2 thermal shutdown) to bring the system into a safe state and to ensure a proper restart of the system. Buck regulator is disabled.

A special mode called SBC Development Mode is available during software development or debugging of the system. All of the operating modes mentioned above can be accessed in this mode. However, the watchdog counter is stopped and does not need to be triggered. This mode can be accessed by setting the TEST pin to GND during SBC Init Mode.

5.1 State Machine Description and SBC Mode Control

The different SBC Modes are selected via SPI by setting the respective SBC **MODE** bits in the register **M_S_CTRL**.

The SBC **MODE** bits are cleared when going through SBC Restart Mode, so the current SBC mode is always shown.

Figure 3**Figure 4** shows the SBC State Diagram.

System Features

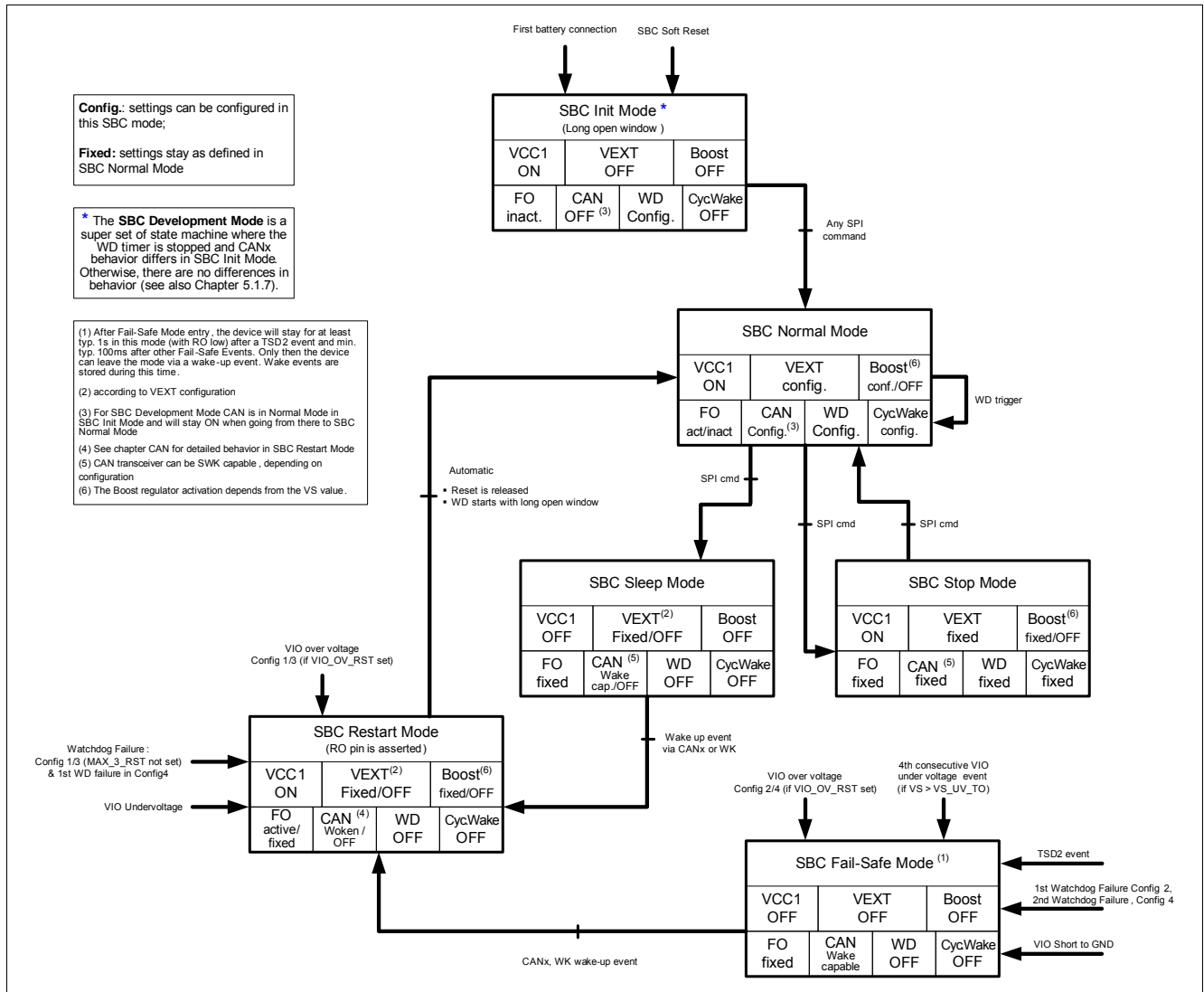

Figure 3 State Diagram showing the SBC Operating Modes

System Features

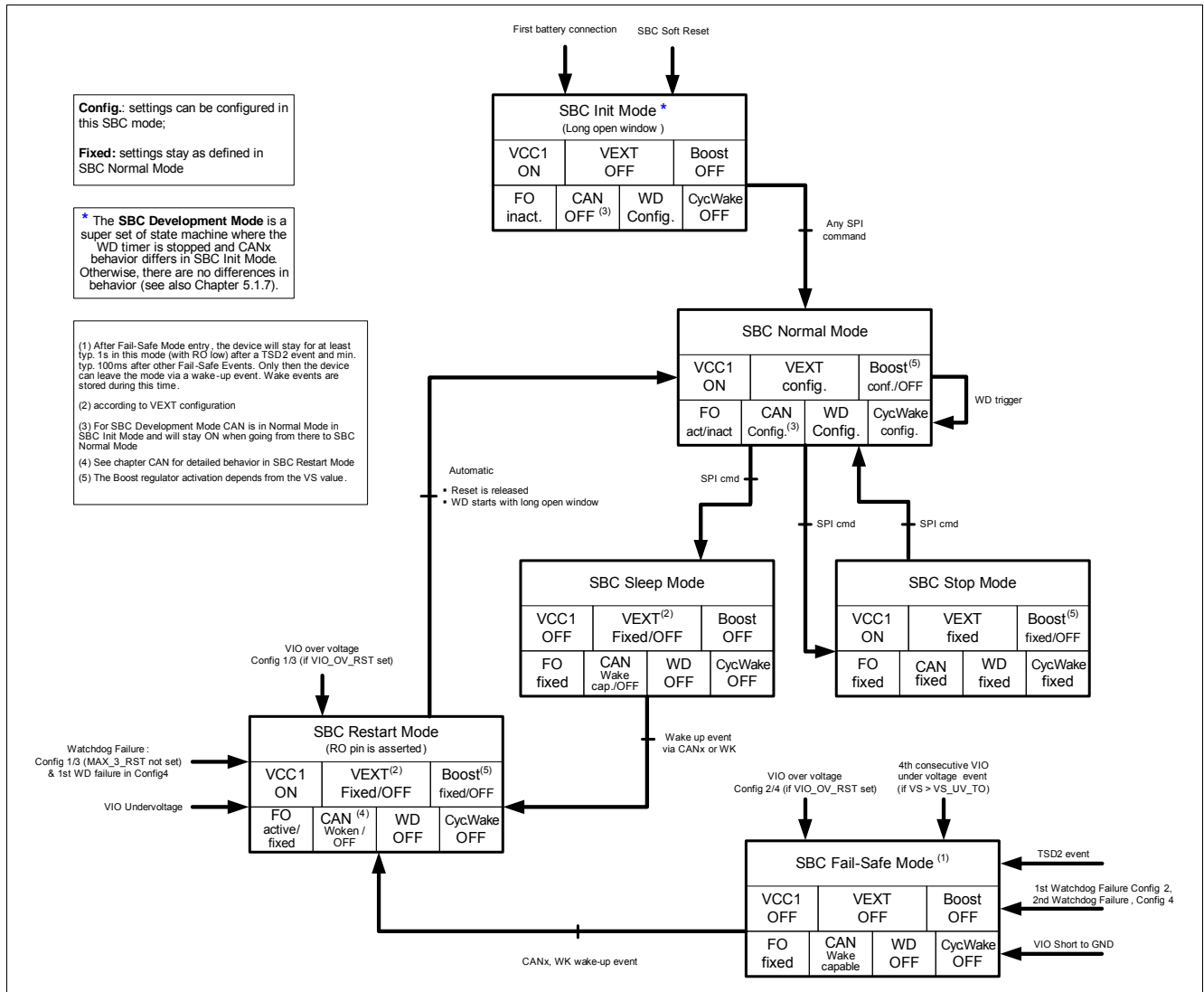

Figure 4 State Diagram showing the SBC Operating Modes

System Features

5.1.1 Device Configuration and SBC Init Mode

The SBC Init Mode is the mode where the hardware configuration of the SBC is stored and where the microcontroller finishes the initialization phase.

The SBC starts up in SBC Init Mode after crossing the power-on reset $V_{POR,r}$ threshold (see also [Chapter 12.3](#)) and the watchdog will start with a long open window (t_{LW} typical 200ms) after the RSTN is released.

During this power-on phase following configurations are stored in the device:

- Supply and Power up configurability.
- The device behavior regarding a watchdog trigger failure and a VIO overvoltage condition is determined by the external circuitry on the INTN pin (see below).
- The selection of the normal device operation or the SBC Software Development Mode (watchdog disabled for debugging purposes) will be set depending on the voltage level of the FO/TEST pin (see also [Chapter 5.1.7](#)).

5.1.1.1 Supply and Power up configurability

The pin VIO of TLE9278BQX V33 has to be connected to VCC1. The pin PCFG can be left open or connected to GND.

The [Table 5](#) shows the only allowed combinations and related behavior.

Table 5 Supply and power up Configurability

VCC1 Output Voltage	PCFG pin	VIO Supply	μ C Supply	VEXT Output voltage	VEXT Behavior	Supervision Functions
$V_{CC1} = 3.3\text{ V}$	Open	VCC1	VCC1	Configurable via SPI using VEXT_VCFG	SPI configurable, OFF after Power Up	Supervision functions on VIO with 3.3 V level; VREG_UV SPI status bit active
$V_{CC1} = 3.3\text{ V}$	GND	VCC1	VCC1	Configurable via SPI using VEXT_VCFG	SPI configurable, OFF after Power Up	Supervision functions on VIO with 3.3 V level; VREG_UV SPI status bit active

Note: VIO can be connected only to VCC1.

5.1.1.2 Watchdog trigger failure configuration

There are four different device configurations ([Table 6](#)) available defining the watchdog failure and the VIO overvoltage behavior. The configurations can be selected via the external connection on the INTN pin and the SPI bit [CFG2](#) in the [HW_CTRL_0](#) register (see also [Chapter 13.4](#)):

- A watchdog trigger failures leads to SBC Restart Mode (Config 1/3) and depending on [CFG2](#) the Fail Output (FO) are activated after the 1st or 2nd watchdog trigger failure;
 If [VIO_OV_RST](#) is set and in Config 1/3, then SBC Restart Mode will be entered in case of [VIO_OV](#) and the FO is activated.
- A watchdog trigger failures leads to SBC Fail-Safe Mode (Config 2/4) and depending on [CFG2](#) the Fail Output (FO) are activated after the 1st or 2nd watchdog trigger failure. The first watchdog trigger failure in Config 4 will lead to SBC Restart Mode;

System Features

If **VIO_OV_RST** is set and in Config 2/4, then SBC Fail-Safe Mode will be entered in case of **VIO_OV** and the FO is activated.

The respective device configuration can be identified by reading the SPI bits **CFG2_STATE** and **CFG1_STATE** in the **WK_LVL_STAT** register.

Table 6 Watchdog Trigger Failure Configuration

Config	Event	FO Activation	SBC Mode Entry	SPI Bit CFG2	INTN Pin (CFG1_STATE)
1	1 × Watchdog Failure	after 1st WD Failure	SBC Restart Mode	1	External pull-up
2	1 × Watchdog Failure	after 1st WD Failure	SBC Fail-Safe Mode	1	No ext. pull-up
3	2 × Watchdog Failure	after 2nd WD Failure	SBC Restart Mode	0	External pull-up
4	2 × Watchdog Failure	after 2nd WD Failure	SBC Fail-Safe Mode	0	No ext. pull-up

The respective configuration will be stored for all conditions and can only be changed by powering down the device ($V_S < V_{POR,f}$).

Table 7 shows the possible SBC hardware configurations.

Table 7 SBC Configuration

Configuration	Description	FO/Test Pin	INTN Pin (CFG1_STATE)	CFG2_STATE	CFG1_STATE
Config 0	Software development mode: no reset is triggered in case of watchdog trigger failure. After the Power Up, one arbitrary SPI command must be sent.	0	-	X	X
Config 1	After missing the WD trigger for the first time, the state of VCC1 remains unchanged, FO pin is active, SBC in Restart Mode	Open or $>V_{TEST,H}$	External pull-up to V_{IO}	1	1
Config 2	After missing the WD trigger for the first time, VCC1 turns OFF, FO pin are active, SBC in Fail-Safe mode	Open or $>V_{TEST,H}$	Open or GND	1	0
Config 3	After missing the WD trigger for the second time, the state of VCC1 remains unchanged, FO pin is active, SBC in Restart Mode	Open or $>V_{TEST,H}$	External pull-up to V_{IO}	0	1
Config 4	After missing the WD trigger for the second time, VCC1 turns OFF, FO pin is active, SBC in Fail-Safe mode	Open or $>V_{TEST,H}$	Open or GND	0	0

In case of 3 consecutive resets due to WD fail, it is possible in Config 1 and 3 not to generate additional reset by setting the **MAX_3_RST** on **WD_CTRL**.

Figure 5 shows the timing diagram of the hardware configuration selection. The hardware configuration is defined during SBC Init Mode. The INTN pin is internally pulled LOW with a weak pull-down resistor during the reset delay time t_{RD1} , i.e. after VIO crosses the reset threshold VRT1 and before the RSTN pin goes HIGH. The

System Features

INTN pin is monitored during this time and the configuration (depending on the voltage level at INTN) is read and stored at the rising edge of RSTN (with a filter time of t_{CFG_F}).

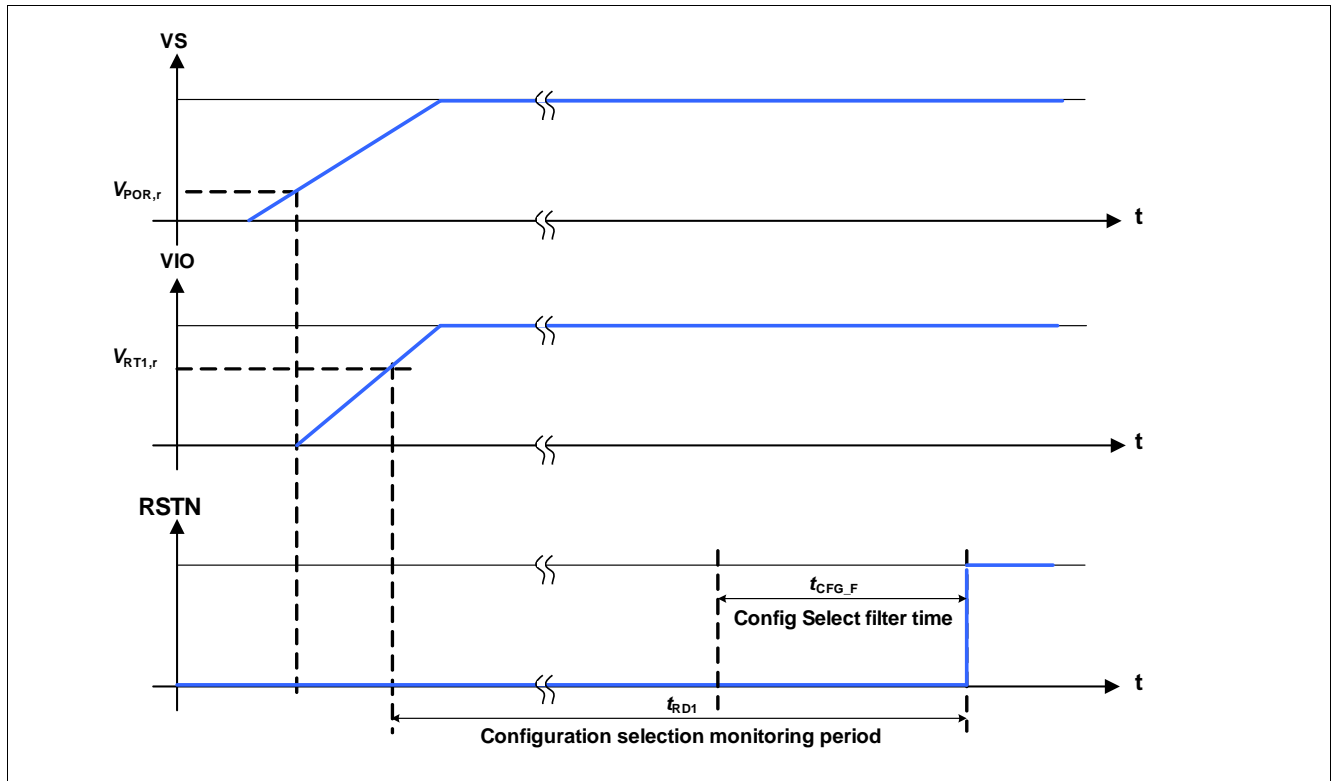

Figure 5 Hardware Selection Timing Diagram

Note: If the **POR** bit is not cleared then the internal pull-down resistor will be reactivated every time RSTN is pulled LOW the configuration will be updated at the rising edge of RSTN. Therefore it is recommended to clear the **POR** bit right after initialization.

5.1.1.3 SBC Init Mode

In SBC Init Mode, the device waits for the microcontroller to finish its startup and initialization sequence. In the SBC Init Mode any SPI command will bring the SBC to SBC Normal Mode. During the long open window the watchdog has to be triggered. Thereby the watchdog will be automatically configured. A missing watchdog trigger during the long open window will cause a watchdog failure and the device will enter SBC Restart Mode.

Wake events are ignored during SBC Init Mode and will therefore be lost.

Note: Any SPI command will bring the SBC to SBC Normal Mode even if non-valid (see **Chapter 13.2**).

Note: For a safe start-up, it is recommended to use the first SPI command to trigger and to configure the watchdog (see **Chapter 12.2**).

Note: At power up, no **VIO_UV** will be issued nor will FO be triggered as long as VIO is below the V_{RT1} threshold and V_S is below the VIO short circuit detection threshold $V_{S,UV}$. The RSTN pin will be kept low as long as VIO is below the selected V_{RT1} threshold. As soon as the VIO is higher than V_{RT1} , the RSTN is released after t_{RD1} .

System Features

5.1.2 SBC Normal Mode

The SBC Normal Mode is the standard operating Mode for the SBC. All configurations have to be done in SBC Normal Mode before entering a low-power mode (see also [Chapter 5.1.6](#) for the device configuration defining the Fail-Safe Mode behavior). A wake-up event on CANx and WK will create an interrupt on pin INTN however, no change of SBC Mode will occur. The configuration options are listed below:

- VCC1 is active, Buck in PWM Mode.
- VEXT can be switched ON or OFF .
- CANx is configurable (OFF coming from SBC Init Mode; OFF or wake capable coming from SBC Restart Mode, see also [Chapter 5.1.5](#)).
- Wake pin level can be monitored and can be selected to be wake capable.
- Cyclic wake period can be configured using [TIMER_CTRL_0](#) and enabled by setting [TIMER1_WK_EN](#).
- Watchdog is configurable.
- FO is OFF by default.

In SBC Normal Mode, there is the possibility of testing the FO output, i.e. to verify if setting the FO pin to low will create the intended behavior within the system. The FO output can be enabled and then disabled again by the microcontroller by setting the [FO_ON](#) SPI bit. This feature is only intended for testing purposes.

5.1.3 SBC Stop Mode

The SBC Stop Mode is the first level technique to reduce the overall current consumption. All kind of settings have to be done before entering SBC Stop Mode. In SBC Stop Mode any kind of SPI write commands are ignored and the [SPI_FAIL](#) bit is set, except for changing to SBC Normal Mode, triggering a SBC Soft Reset, refreshing the watchdog, changing modulation of the buck. The configuration options are listed below:

- VCC1 is ON, Buck in PFM Mode if $I_{VCC1} < I_{PFM-PWM,TH}$.
- VEXT is fixed ON or OFF in accordance with SPI configuration.
- CANx can be selected for 'Receive Only Mode', to be wake capable or OFF.
- WK pin can be selected to be wake capable, PWM_BY_WK (switch PFM/PWM buck modulation) or OFF.
- Wake capability via cyclic wake can be selected.
- Watchdog is fixed or OFF (if WD disable sequence was executed).

A wake-up event on CANx and WK will create an interrupt on pin INTN however, no change of SBC Mode will occur.

In SBC Stop Mode, it is allowed to use the Boost module (enabled before to enter in SBC Stop Mode) in case of the V_S is dropping. The Boost works only in PWM and therefore the total amount of current consumption will increase.

Note: It is not possible to switch directly from SBC Stop Mode to SBC Sleep Mode. Doing so will also set the [SPI_FAIL](#) flag and will bring the SBC into Normal Mode via SBC Restart Mode.

5.1.4 SBC Sleep Mode

The SBC Sleep Mode is the second level technique to reduce the overall current consumption to a minimum needed to react on wake-up events.

All settings must be done before entering SBC Sleep Mode. In case that SPI configurations in Sleep Mode have been sent to the SBC, the commands are ignored and no reactions from the SBC.

The configuration options are listed below:

System Features

- VCC1 is OFF.
- VEXT is fixed ON or OFF in accordance with SPI configuration.
- CANx can be selected to be wake capable or OFF.
- WK pin can be selected to be wake capable or OFF.

A wake-up event on CANx or WK pin will bring the device via SBC Restart Mode into SBC Normal Mode again and signal the wake event and corresponding sources.

It is not possible to switch off all wake sources in Sleep Mode. This will lead to SBC Normal Mode via SBC Restart Mode instead.

In order to enter SBC Sleep Mode successfully, all wake source signalization flags from **WK_STAT_0** and **WK_STAT_2** need to be cleared. If a failure to do so, will result in an immediate wake-up from SBC Sleep Mode by going via SBC Restart to Normal Mode.

Note: As soon as the Sleep Command is sent, the Reset will go low to avoid any undefined behavior between SBC and microcontroller.

5.1.5 SBC Restart Mode

There are multiple reasons to enter the SBC Restart Mode. The purpose of the SBC Restart Mode is to reset the microcontroller:

- From SBC Normal and Stop Mode, it is reached in case of undervoltage on VIO. In case of 4 consecutive **VIO_UV** events, SBC Fail-Safe Mode is entered.
- From SBC Normal and Stop Mode it is reached in case of overvoltage on VIO in config 1/3 if **VIO_OV_RST** is set.
- Incorrect Watchdog triggering (depending of the configuration).
- From SBC Sleep and Fail-Safe Mode to ramp up VIO supply after wake event.

From SBC Restart Mode, the SBC goes automatically to SBC Normal Mode, i.e the mode is left automatically by the SBC without any microcontroller influence once the VIO_UV condition is not present anymore and when the reset delay time (**t_{RD1}**) has expired. The Reset Output (RSTN) is released at the transition.

Entering or leaving the SBC Restart Mode will not result in deactivation of the Fail output.

The following functions are not changed in SBC Restart mode:

- VEXT is fixed ON or OFF in accordance with SPI configuration.
- VCC1 is ON or ramping up.
- BOOST is fixed or OFF.

Table 8 contains detailed descriptions of the reason to restart:

Table 8 Reasons for Restart - State of SPI Status Bits after Return to Normal Mode

SBC Mode	Event	DEV_STAT	WD_FAIL	VIO_UV	VIO_OV
Normal	Watchdog Failure	01	01	x	x
Normal	VIO undervoltage reset	01	xx	1	x
Normal	VIO overvoltage (VIO_OV_RST=1)	01	xx	x	1
Sleep Mode	Wake-up event	10	xx	x	x
Stop Mode	Watchdog Failure	01	01	x	x

System Features

Table 8 Reasons for Restart - State of SPI Status Bits after Return to Normal Mode (cont'd)

SBC Mode	Event	DEV_STAT	WD_FAIL	VIO_UV	VIO_OV
Stop Mode	VIO undervoltage reset	01	xx	1	x
Stop Mode	VIO overvoltage (VIO_OV_RST=1)	01	xx	x	1
Fail-Safe	Wake-up event	01	see “Reasons for Fail-Safe, Table 9 ”		

5.1.6 SBC Fail-Safe Mode

The purpose of this mode is to bring the system in a safe status after a failure condition by turning off the VCC1 and VEXT supply and the FO pin is automatically activated. After a wake-up event the system is then able to restart again.

The Fail-Safe Mode is automatically reached in case of:

- Overtemperature condition (TSD2).
- After 1 or 2 watchdog fails (depending on config setting).
- At the 4th consecutive VIO undervoltage event.
- From SBC Normal and Stop Mode, in case of overvoltage on VIO in config 2/4, if **VIO_OV_RST** is set.
- VIO is shorted to GND.
- VIO is below the VRTx for time longer than $t_{VIO,sc}$.

In this case, the default wake sources are activated, the wake-up events are cleared in the register **WK_STAT_0** and **WK_STAT_2**.

The mode will be maintained for at least t_{TSD2} in case of TSD2 event and $t_{FS,min}$ in case of other failure events to avoid any fast toggling behavior. All wake sources will be masked during this time but the wake-up events will be stored. Stored wake-up events and wake-up event after this minimum waiting time, will lead to SBC Restart Mode. Leaving the SBC Fail-Safe Mode will not result in deactivation of the Fail Output pin.

The following functions are influenced during SBC Fail-Safe Mode:

- FO output is activated.
- VCC1 is OFF.
- VEXT is OFF.
- CANx is wake capable.
- WK is wake capable (in case that **PWM_BY_WK** was set, moving to SBC Fail-Safe Mode will clear the bit).
- Cyclic wake is disabled.

Table 9 Reasons for Fail-Safe - State of SPI Status Bits after Return to Normal Mode

Mode	Config	Event	DEV_STAT	TSD2	WD_FAIL	VIO_UV	VIO_SC	VIO_OV
Normal	2	1 × watchdog failure	01	x	01	x	0	x
Normal	4	2 × watchdog failure	01	x	10	x	0	x
Normal	1, 2, 3, 4	TSD2	01	1	xx	x	0	x
Normal	1, 2, 3, 4	VIO short to GND	01	x	xx	1	1	x
Normal	2, 4	VIO overvoltage (VIO_OV_RST=1 , CFG2=1)	01	x	xx	x	0	1

System Features

Table 9 Reasons for Fail-Safe - State of SPI Status Bits after Return to Normal Mode (cont'd)

Mode	Config	Event	DEV_STAT	TSD2	WD_FAIL	VIO_UV	VIO_SC	VIO_OV
Stop Mode	2	1 × watchdog failure	01	x	01	x	0	x
Stop Mode	4	2 × watchdog failure	01	x	10	x	0	x
Stop Mode	1, 2, 3, 4	TSD2	01	1	xx	x	0	x
Stop Mode	1, 2, 3, 4	VIO short to GND	01	x	xx	1	1	x
Stop Mode	2, 4	VIO overvoltage (VIO_OV_RST=1, CFG2=1)	01	x	xx	x	0	1

5.1.7 SBC Development Mode

The SBC Development Mode is used during development phase of the application, especially for software development.

Compared to the default SBC user mode operation, this mode is a super set of the state machine. The device will start also in SBC Init Mode and it is possible to use all the SBC Modes and functions with following differences:

- Watchdog is stopped and does not need to be triggered. Therefore no reset is triggered due to watchdog failure.
- SBC Fail-Safe and Restart Mode are not reached due to watchdog failure but the other reasons to enter these modes are still valid.
- CANx default value in SBC INIT MODE is ON instead of OFF.

The mode is reached by setting the FO/TEST pin to LOW for the entire SBC INIT Mode and by sending an arbitrary SPI command. The SBC Init Mode is reachable after the power-up or sending a software reset.

SBC Development Mode can only be left by a power-down or by providing a SBC Software Reset using the **MODE** bits on **M_S_CTRL** register while FO/TEST is high or open.

When the FO/TEST pin is left open, or connected to V_S during the start-up, the SBC starts into normal operation. The FO/TEST pin has an integrated pull-up resistor (switched ON only during SBC Init Mode) to prevent the SBC device from starting in Software Development Mode during normal life of the vehicle. To avoid any disturbances, the FO/TEST pin is monitored during the SBC Init Mode when the RSTN is HIGH until SBC Init Mode is left. Only if the FO/TEST pin is LOW for the Init Mode time when the RSTN is HIGH, SBC Software Development Mode is reached and stored.

System Features

5.2 Wake Features

Following wake sources are implemented in the device:

- Static Sense: WK input is permanently active (see [Chapter 9](#)).
- Cyclic Wake: internal wake source controlled via internal timer (see [Chapter 5.2.1](#)).
- CANx wake: wake-up via CAN message (see [Chapter 8](#)).

The wake source must be set before entering in SBC Sleep Mode. In case of critical situation, when the device will be set into SBC Fail-Safe mode, all default wake sources will be activated. For additional information about setting, refer to the respective chapters.

5.2.1 Cyclic Wake

The cyclic wake feature is intended to reduce the quiescent current of the device and application.

When the cyclic wake is enabled, a periodic INTN is generated in SBC Normal and Stop Mode based on the setting of [TIMER_CTRL_0](#).

The correct sequence to configure the cyclic wake is shown in [Figure 6](#). The sequence is as follows:

- Disable the cyclic wake feature to ensure that there is not unintentional interrupt when activating cyclic wake ([TIMER1_WK_EN](#) = 0).
- Configure the cyclic wake timer period in [TIMER_CTRL_0](#) register.
- Enable the cyclic wake as a wake-up source in the register [WK_CTRL_0](#) ([TIMER1_WK_EN](#) = 1).

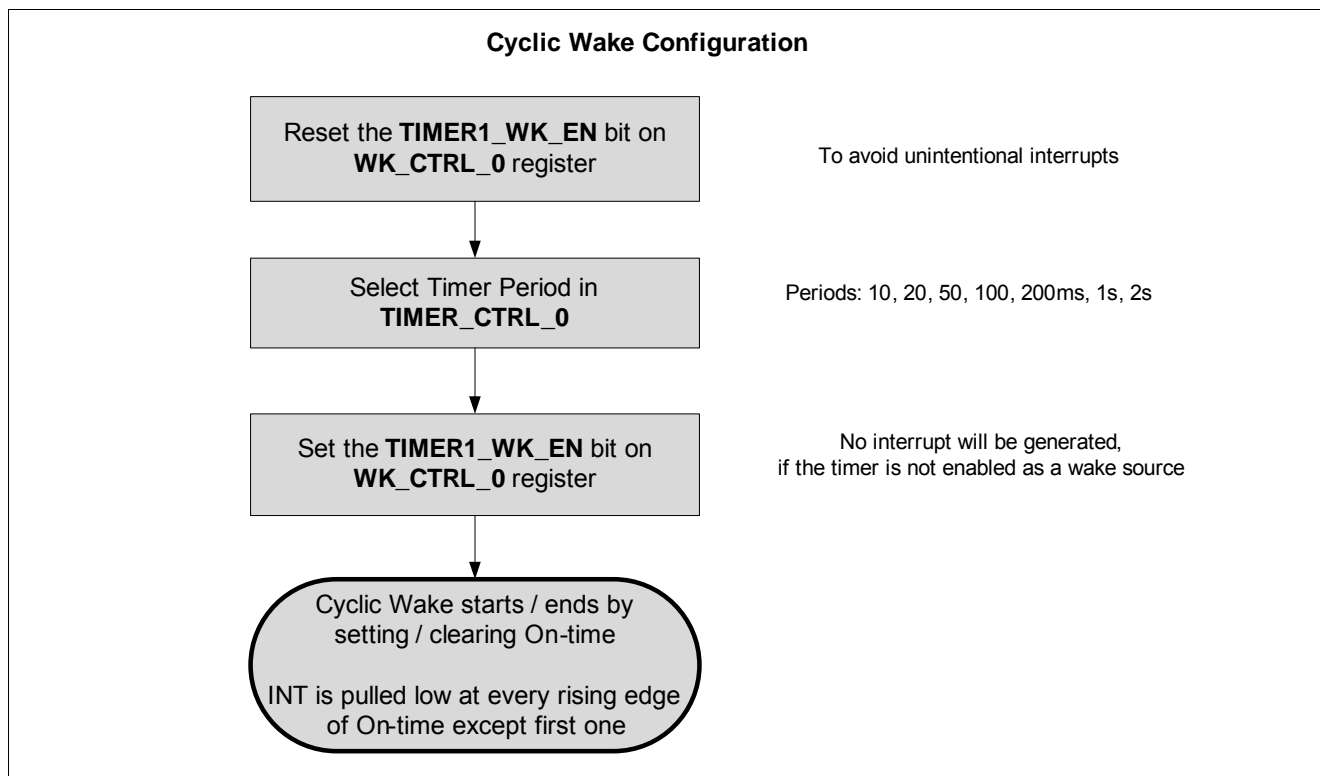

Figure 6 Cyclic Wake: Configuration and Sequence

5.2.2 Internal Timer

The integrated timer is typically used to wake up the microcontroller periodically (cyclic wake).

Following periods can be selected via the register [TIMER_CTRL_0](#):

- Period: 10ms / 20ms / 50ms / 100ms / 200ms / 1s / 2s

6 DC/DC Regulator

6.1 Block Description

The SMPS module in the TLE9278BQX V33 is implemented as a cascade of a step-up regulator followed by a step-down post-regulator. The step-up regulator (DC/DC Boost converter) provides a V_S level which permits the step-down post-regulator (DC/DC Buck converter) to regulate without entering a low-drop condition.

The SMPS module is active in SBC Normal, Stop and Restart Mode. In SBC Sleep and Fail-Safe Mode, the SMPS module is disabled.

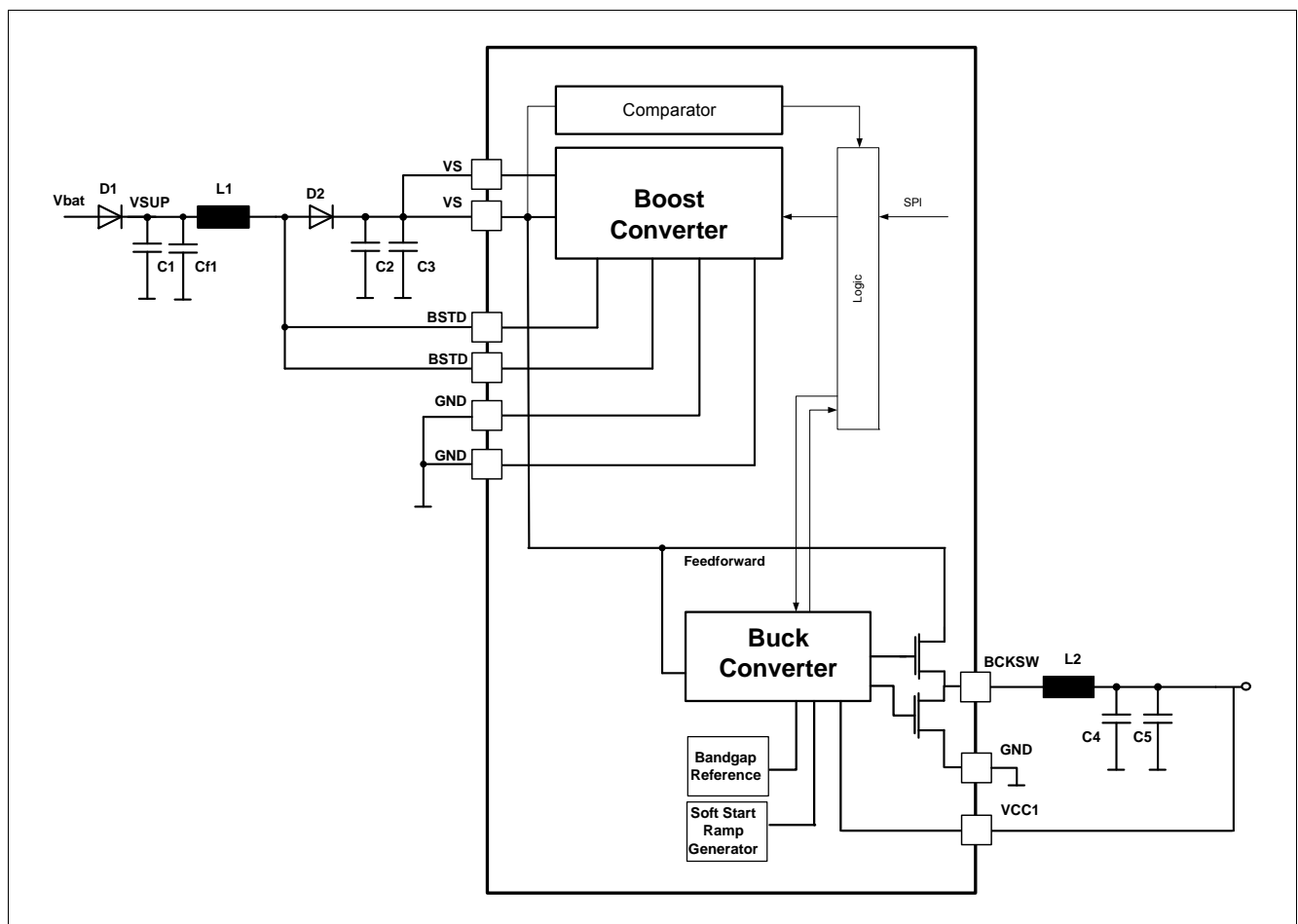

Figure 7 DC/DC Block Diagram

Functional Features

- 3.3 V SMPS (DC/DC) Buck Regulator with integrated high-side and low-side power switching transistor.
- SMPS (DC/DC) Boost Regulator for low V_{SUP} supply voltage with integrated power transistor.
- Adjustable output DC/DC Boost pre-regulator voltage via SPI.
- Fixed switching frequency for Buck and Boost Regulator in SBC Normal Mode in PWM (Pulse Width Modulation).
- PFM (Pulse Frequency Modulation) for Buck converter in SBC Stop Mode to reduce the quiescent current.
- Automatic transition PFM to PWM in SBC Stop Mode.
- Soft start-up.

DC/DC Regulator

- Edge Shaping for better EMC performances for Buck and Boost regulator.
- Undervoltage monitoring via VIO pin with adjustable reset level (refer to [Chapter 12.7](#)).
- Overvoltage detection via VIO pin activates the FO pin in case that **VIO_OV_RST** bit is set (refer to [Chapter 12.8](#)).
- Buck short circuit detection.
- Buck 100% Duty Cycle at low V_S operation.
- Buck overcurrent peak detection.
- Boost overcurrent peak detection.

6.1.1 Functional Description of the Buck Converter

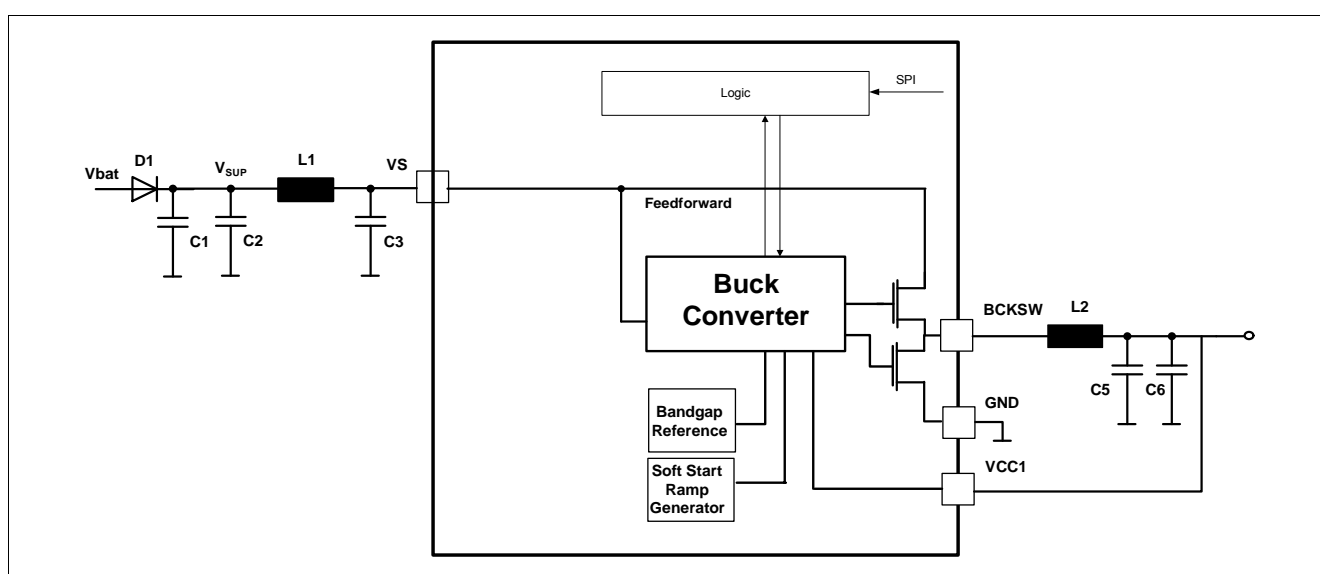

Figure 8 Buck Block Diagram

The DC/DC Buck converter is intended as post-regulator (VCC1) and it provides a step down converter function transferring energy from V_S to a lower output voltage with high efficiency (typically more than 80%). The output voltage is 3.3 V in a current range up to 750 mA. It is regulated via a digital loop with a precision of $\pm 2\%$. It requires an external inductor and capacitor filter on the output switching pin (BCKSW). The Buck regulator has integrated high-side and low-side power switching transistors. The compensation of the regulation loop is done internally and no additional external components are needed.

A typical application example and external components proposal is available in [Chapter 14.1](#).

The Buck converter is active in SBC Normal, Stop and Restart Mode and it is disabled in SBC Sleep and Fail-Safe Mode.

Depending on the SBC Mode, the Buck converter works in two different modes:

- PWM Mode (Pulse Width Modulation): This mode is available in SBC Normal Mode, SBC Restart Mode and SBC Stop Mode (only for automatic or manual PFM to PWM transitions. Refer to [Chapter 6.2.2](#)). In PWM, the Buck converter operates with a fixed switching frequency (f_{BUK}). The duty cycle is calculated internally based on input voltage, output voltage and output current. The precision is $\pm 2\%$ on input supply and output current range (refer to [Figure 13](#) for more information). In PWM Mode, the Buck converter is capable of a 100% duty cycle in case of low V_S conditions. In order to reduce EMC, the edge shaping feature has been implemented to control the activation and deactivation of the two power switches.

DC/DC Regulator

- PFM Mode (Pulse Frequency Modulation): This mode is activated automatically when the SBC Stop Mode is entered. The PFM Mode is an asynchronous mode. PFM Mode does not have a controller switching frequency. The switching frequency depends on conditions of the Buck regulator such as the following: input supply voltage, output voltage, output current and external components. A typical timing diagram is shown in [Figure 9](#). The Buck converter in PFM Mode has a tolerance of $\pm 4\%$. The transition from PFM mode to PWM mode is described in [Chapter 6.2.2](#).

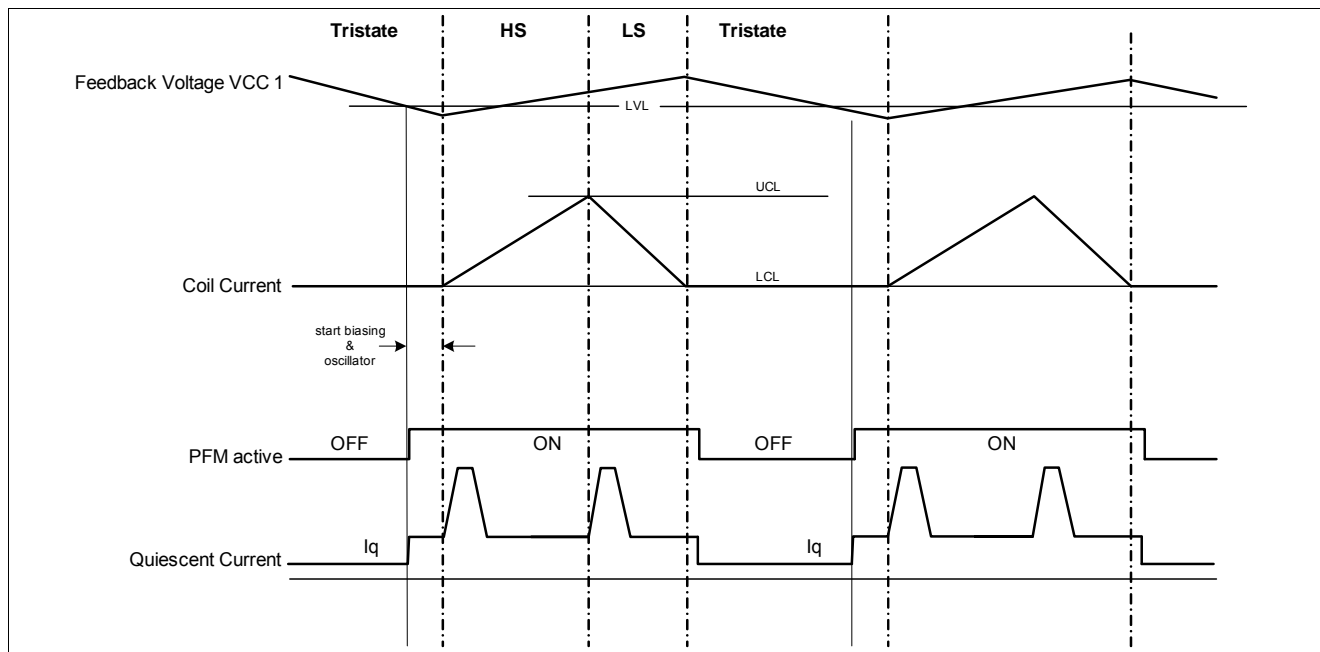

Figure 9 Typical PFM timing diagram

6.1.1.1 Startup Procedure (Soft Start)

The Startup Procedure (Soft Start) permits to achieve the Buck regulator output voltage avoiding large overshoot on the output voltage. This feature is activated during the power-up, from SBC Sleep to Restart Mode and from SBC Fail-Safe to SBC Restart Mode.

When the Buck regulator is activated, it starts in open loop with a minimum duty cycle which is maintained for a limited number of switching periods. After this first phase, the duty cycle is linearly increased by a fixed step and it is maintained for a limited number of switching periods for each duty cycle step. This procedure is repeated until the target output voltage value of the Buck regulator is reached. As soon as the Buck regulator output voltage is reached, the regulation loop is closed and it starts to operate normally using PWM Mode adjusting the duty cycle according to the Buck input and output voltages and the output current.

6.1.1.2 Buck regulator Status register

The register [SMPS_STAT](#) contains information about the open or short conditions on BCKSW pin. No SBC Mode or configuration changes are triggered if one bit on [SMPS_STAT](#) register is set.

6.1.1.3 External components

The Buck converter needs one inductor and output capacitor filter. The inductor has a fixed value of 47 μH . Secondary parameters such as saturation current must be selected based on the maximum current capability needed in the application.

The output filter capacitors are two parallel 22 μF ceramic capacitor. For additional information, refer to [Chapter 14.1](#).

DC/DC Regulator

6.1.2 Functional Description of the Boost Converter

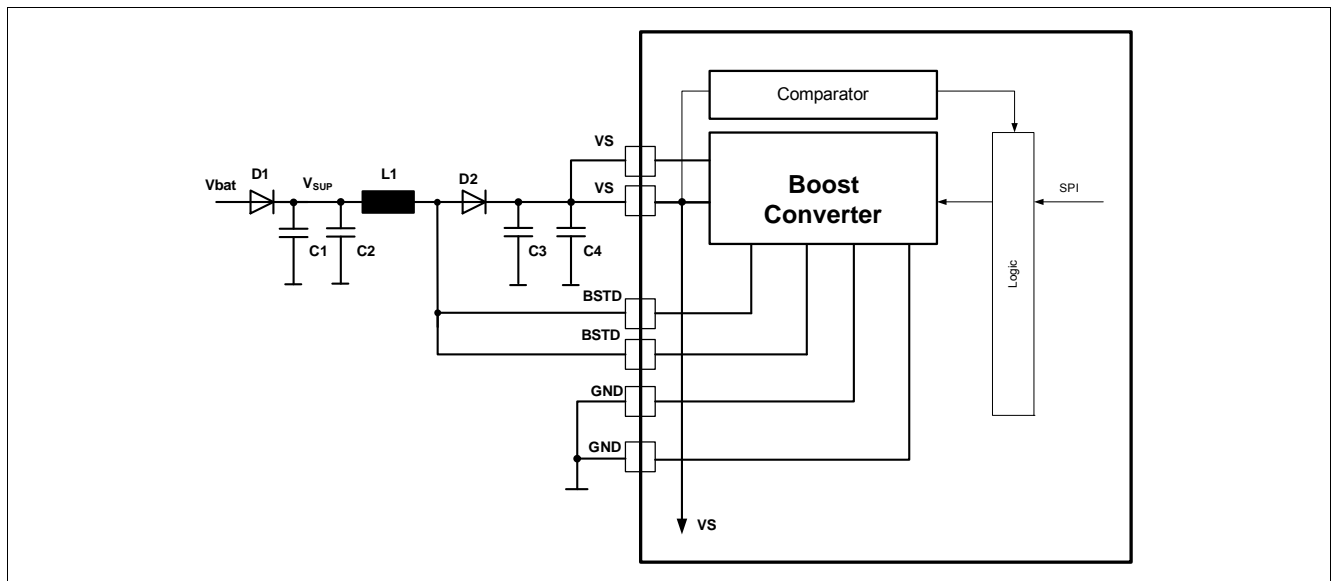

Figure 10 Boost Block Diagram

The Boost converter is intended as a pre-regulator and it provides a step up converter function. It transfers energy from an input supply V_{SUP} (battery voltage after reverse protection circuit) to a higher output voltage (V_S) with high efficiency (typically more than 80%).

The regulator integrates the power switching and the sense resistor for overcurrent detection.

The Boost regulator can be enabled in SBC Normal Mode via SPI (register `HW_CTRL_0`, bit `BOOST_EN`) and four output voltage values are selectable via `BOOST_V`. The Boost regulator can also be active in SBC Stop and Restart Mode. The selected boost output voltage will automatically define the voltage thresholds where the boost will be ON ($V_{BST,TH1}$, $V_{BST,TH2}$, $V_{BST,TH3}$ and $V_{BST,TH4}$). If the Boost regulator is enabled, it switches ON automatically when V_S falls below the selected threshold voltage and switches OFF when crossing this threshold including hysteresis again. The bit `BST_ACT` on `SMPS_STAT` register indicates that the Boost has been activated.

The Boost output voltage can be changed only if `BOOST_EN` is set to 0. In case that the boost output voltage configuration changes with `BOOST_EN` set to 1, the `SPI_FAIL` bit is set and the command is ignored.

Figure 11 shows the typical timing for enabling the Boost converter.

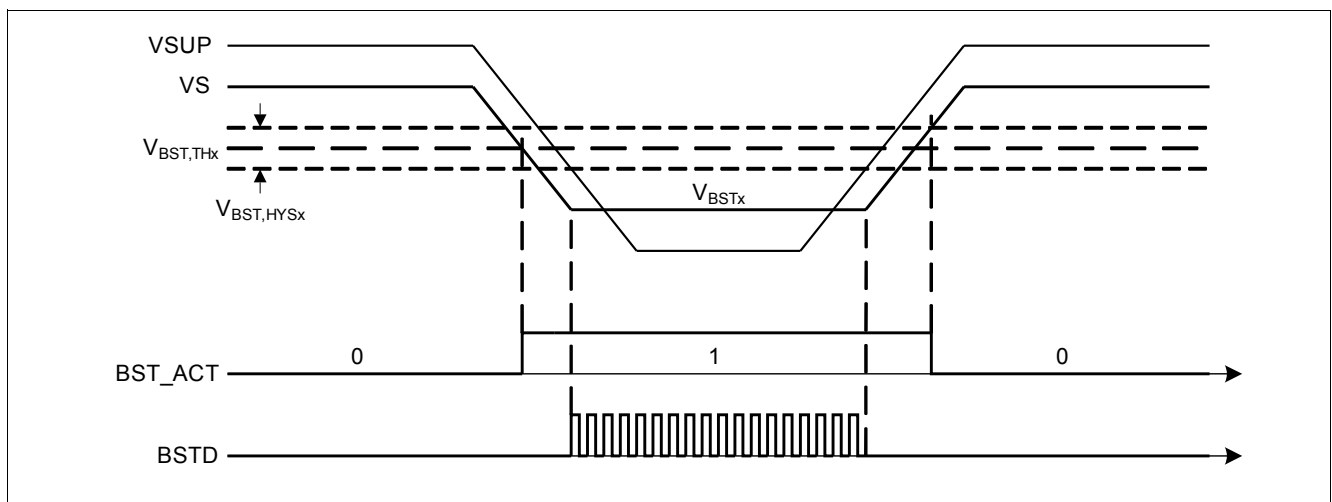

Figure 11 Boost converter activation

DC/DC Regulator

The Boost regulator works in PWM Mode with fixed frequency (f_{BST}) and a tolerance of $\pm 3\%$.
If the Boost is enabled in Stop Mode, the quiescent current in the SBC is increased (P_4.4.31).

6.1.2.1 Boost Regulator Status register

The register **SMPS_STAT** contains information about the open or short conditions on Boost pins including loss of GND detection. No SBC mode or configuration is triggered if one bit is set on the **SMPS_STAT** register.

6.1.2.2 External Components

The Boost converter requires a number of external components such as the following: input buffer capacitor on the battery voltage, inductor, freewheeling diode and filter capacitors.

For recommend external components and corresponding values, refer to **Chapter 14.1**.

DC/DC Regulator

6.2 Power Scenarios

The chapter describes the features and performance of the Buck regulator according to SBC modes. The Boost module works only in SBC Normal or Stop Mode using PWM modulation (refer also to [Chapter 6.1.2](#)).

6.2.1 Buck behavior in SBC Normal Mode

In SBC Normal Mode the Buck works in PWM mode with fixed switching frequency. All supervision functions for Buck converter are available in SBC Normal Mode and available depending the device configuration ([Chapter 5.1.1](#)). For additional details on the supervision functions, refer to [Chapter 12.7](#), [Chapter 12.8](#), [Chapter 12.9](#) and [Chapter 12.11](#).

6.2.2 Buck behavior in SBC Stop Mode

The SBC Stop Mode operation is intended to reduce the total amount of quiescent current while still providing output voltage. In order to achieve this, the Buck regulator changes the modulation from PWM (Pulse Width Modulation) to PFM (Pulse Frequency Modulation) when entering SBC Stop Mode.

In SBC Stop Mode, the Buck modulation can change as follow:

- Buck module always in PFM modulation (default setting).
- Automatically change from PFM to PWM (setting [PWM_AUTO](#)).
- Modulation is controlled by the WK pin (setting [PWM_BY_WK](#)).

If the [PWM_BY_WK](#) and [PWM_AUTO](#) are set at the same time, the [PWM_AUTO](#) has highest priority and PWM automatic transition will be used.

If [PWM_BY_WK](#) and [PWM_AUTO](#) are at the same time set to 0, the buck module remains in PFM in SBC Stop Mode.

If in SBC Stop Mode the Buck modulation is PWM, the buck output voltage tolerance and output current capability are like SBC Normal Mode (P_6.5.13 and P_6.5.46).

6.2.2.1 Automatic Transition from PFM to PWM in SBC Stop Mode

If more current is needed, an automatic transition from PFM to PWM mode is implemented. When the Buck regulator output current exceeds the $I_{\text{PFM-PWM,TH}}$ threshold, the Buck module changes the modulation to PWM and an INTN event is generated. In addition, the [PFM_PWM](#) bit on [WK_STAT_0](#) is set.

In order to set the Buck modulation again in PFM mode, a SBC Stop Mode command has to be write to [M_S_CTRL](#) register. This command has to be sent when the required Buck output current is below the $I_{\text{PFM-PWM,TH}}$ threshold.

By default, the feature is disable. To enable the automatic transition from PFM to PWM, the [PWM_AUTO](#) bit in [HW_CTRL_0](#) has to be set before entering SBC Stop Mode.

When entering SBC Stop Mode, the automatic transition from PFM to PWM mode is activated after the transition time (t_{lag}), during which the Buck regulator loop changes the modulation technique. [Figure 12](#) shows the timing transition from SBC Normal to Stop Mode.

The transition time t_{lag} is always implemented in case of transition from PWM to PFM modulation.

DC/DC Regulator

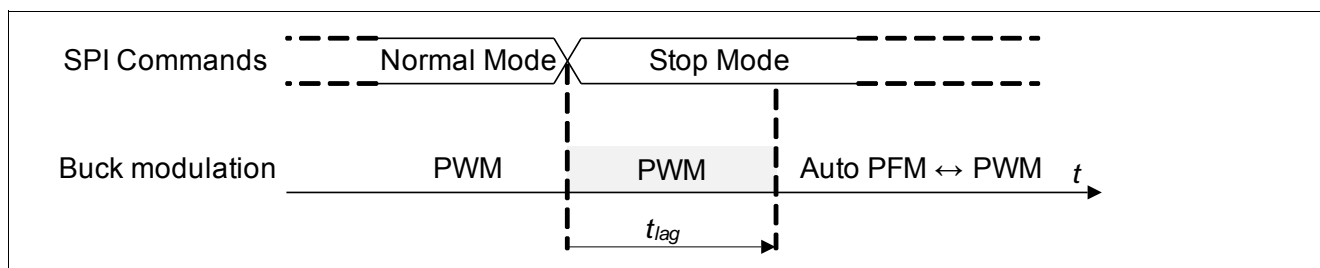

Figure 12 Transition from SBC Normal to SBC Stop Mode

The t_{lag} can be configured via SPI using the **PWM_TLAG** in **HW_CTRL_0** register.

The automatic transition from PFM to PWM can be disabled by setting the **PWM_AUTO** to 0 in the **HW_CTRL_0** register.

6.2.2.2 Manual Transition from PFM to PWM in SBC Stop Mode

The PFM to PWM transition can also be controlled by the microcontroller or an external signal by using the WK pin as a trigger signal in SBC Stop Mode.

When the **PWM_BY_WK** bit is set to 1, the Buck regulator can be switched from PFM to PWM using the WK pin. A LOW level at the WK pin will switch the Buck converter to PFM mode, a HIGH level will switch the Buck converter to PWM Mode. In this configuration, the transition time t_{lag} is not taken into account because a defined signal from microcontroller or external source is expected.

6.2.2.3 SBC Stop to Normal Mode transition

The microcontroller sends an SPI command to switch from SBC Stop Mode to SBC Normal Mode. In this transition, the Buck regulator changes the modulation from PFM to PWM.

Once the SPI command for the SBC Normal Mode transition is received, the Buck output current is able to rise above the specified maximum Stop Mode current ($I_{PFM-PWM,TH}$).

If the transition from SBC Stop Mode to SBC Normal Mode is carried out when the Boost is enabled and operating, it will continue to operate without any changes.

6.2.3 Buck behavior in SBC Sleep or Fail Safe Mode

In SBC Sleep or Fail Safe Mode, the Buck and Boost converter are off and not operating. The lowest quiescent current is achievable.

6.2.3.1 SBC Sleep/Fail Safe Mode to SBC Normal Mode transition

In case of a wake-up event from WK pin or transceivers, the SBC will be set to SBC Restart Mode and as soon as the reset is released, into SBC Normal Mode.

In SBC Restart Mode, the Buck regulator is activated and ramping-up. The Boost regulator is activated and ramping-up again (in case the V_S is below the selected threshold) in according the configuration selected in SBC Normal Mode. As soon as the Buck output voltage exceeds the reset threshold, the RSTN pin is released.

DC/DC Regulator

6.3 Electrical Characteristics

Table 10 Electrical Characteristics

$T_j = -40^\circ\text{C}$ to $+150^\circ\text{C}$; $V_S = 5.5\text{ V}$ to 28 V ; all voltages with respect to ground, positive current flowing into pin (unless otherwise specified)

Parameter	Symbol	Values			Unit	Note or Test Condition	Number
		Min.	Typ.	Max.			
Buck Regulator							
Output Voltage PWM including Line and Load regulation	$V_{CC1,out1}$	3.23	3.3	3.37	V	SBC Normal Mode (PWM) $1\text{ mA} < I_{VCC1} < 750\text{ mA}$ $6.5\text{ V} < V_S < 28\text{ V}$ Boost Disable	P_6.5.13
Output Voltage PWM including Line and Load regulation	$V_{CC1,out1}$	3.23	3.3	3.37	V	¹⁾ SBC Normal Mode (PWM) $I_{VCC1} = 400\text{ mA}$ $V_S = 4\text{ V}$ Boost Disable	P_6.5.46
Output Voltage PFM including Line and Load regulation	$V_{CC1,out2}$	3.16	3.3	3.44	V	SBC Stop Mode (PFM) $10\text{ }\mu\text{A} < I_{VCC1} < I_{PFM-PWM,TH}$ $6.5\text{ V} < V_S < 28\text{ V}$ Boost Disable	P_6.5.14
Output Voltage PFM including Line and Load regulation	$V_{CC1,out3}$	3.18	3.3	3.39	V	SBC Stop Mode (PFM) $10\text{ }\mu\text{A} < I_{VCC1} < 50\text{ mA}$ $6.5\text{ V} < V_S < 28\text{ V}$ Boost Disable	P_6.5.48
Power Stage on-resistance High-Side	$R_{DSON1,HS}$	–	–	1.3	Ω	$V_S = 6.5\text{ V}$ $I_{VS} = 100\text{ mA}$	P_6.5.3
Power Stage on-resistance Low-Side	$R_{DSON1,LS}$	–	–	1.3	Ω	$I_{BCKSW} = 100\text{ mA}$	P_6.5.20
Overcurrent peak limitation internal high side	$I_{BCK_LIM,TH}$	0.85	1.05	1.2	A	$V_S > 6.5\text{ V}$	P_6.5.40
Buck switching frequency	f_{BUK}	405	450	495	kHz	SBC Normal Mode (PWM)	P_6.5.5
Automatic transition PFM to PWM threshold	$I_{PFM-PWM,TH}$	80	110	150	mA	¹⁾ SBC Stop Mode (PFM) $6.5\text{ V} < V_S < 28\text{ V}$	P_6.5.6
Transition time from PWM to PFM	t_{lag}	–	1	–	ms	¹⁾ PWM_TLAG=1 (on HW_CTRL_0)	P_6.5.15
Transition time from PWM to PFM	t_{lag}	–	100	–	μs	¹⁾ PWM_TLAG=0 (on HW_CTRL_0)	P_6.5.16

Boost Regulator

DC/DC Regulator

Table 10 Electrical Characteristics (cont'd)

$T_j = -40^\circ\text{C}$ to $+150^\circ\text{C}$; $V_S = 5.5\text{ V}$ to 28 V ; all voltages with respect to ground, positive current flowing into pin (unless otherwise specified)

Parameter	Symbol	Values			Unit	Note or Test Condition	Number
		Min.	Typ.	Max.			
Boost Voltage 1 including Line and Load regulation	V_{BST1}	6.5	6.7	6.9	V	2) SBC Normal Mode $V_{\text{SUP}} = 3\text{ V}$ $I_{\text{VS}} = 550\text{ mA}$ Boost enabled BOOST_V = 00 _B	P_6.5.7
Boost Voltage 2 including Line and Load regulation	V_{BST2}	7.76	8	8.24	V	2) SBC Normal Mode $V_{\text{SUP}} = 3\text{ V}$ $I_{\text{VS}} = 450\text{ mA}$ Boost enabled BOOST_V = 01 _B	P_6.5.8
Boost Voltage 3 including Line and Load regulation	V_{BST3}	9.7	10	10.3	V	2) SBC Normal Mode $V_{\text{SUP}} = 3\text{ V}$ $I_{\text{VS}} = 300\text{ mA}$ Boost enabled BOOST_V = 10 _B	P_6.5.28
Boost Voltage 4 including Line and Load regulation	V_{BST4}	11.64	12	12.36	V	2) SBC Normal Mode $V_{\text{SUP}} = 3\text{ V}$ $I_{\text{VS}} = 250\text{ mA}$ Boost enabled BOOST_V = 11 _B	P_6.5.31
Boost Switch ON voltage	$V_{\text{BST,TH1}}$	6.50	7	7.30	V	Boost enabled, V_S falling BOOST_V = 00 _B	P_6.5.9
Boost Switch ON voltage	$V_{\text{BST,TH2}}$	7.90	8.5	8.90	V	Boost enabled, V_S falling BOOST_V = 01 _B	P_6.5.18
Boost Switch ON voltage	$V_{\text{BST,TH3}}$	9.80	10.5	10.80	V	Boost enabled, V_S falling BOOST_V = 10 _B	P_6.5.34
Boost Switch ON voltage	$V_{\text{BST,TH4}}$	11.7	12.5	13.0	V	Boost enabled, V_S falling BOOST_V = 11 _B	P_6.5.35
Boost Switch ON/OFF hysteresis	$V_{\text{BST,HYS}}$	0.35	0.5	0.70	V	Boost enabled	P_6.5.10
Overcurrent peak limitation internal switch	$I_{\text{BST_LIM,TH}}$	1.7	2.0	2.3	A	Boost enable $V_{\text{SUP}} \geq 3\text{ V}$	P_6.5.11
Boost switching frequency	f_{BST}	405	450	495	kHz	SBC Normal Mode (PWM)	P_6.5.12

1) Not subject to production test, specified by design.

2) Values verified in characterization with Boost converter external components specified in [Chapter 14.1](#). No subject to production test; specified by design. Refer to [Figure 14](#) for additional information.

DC/DC Regulator

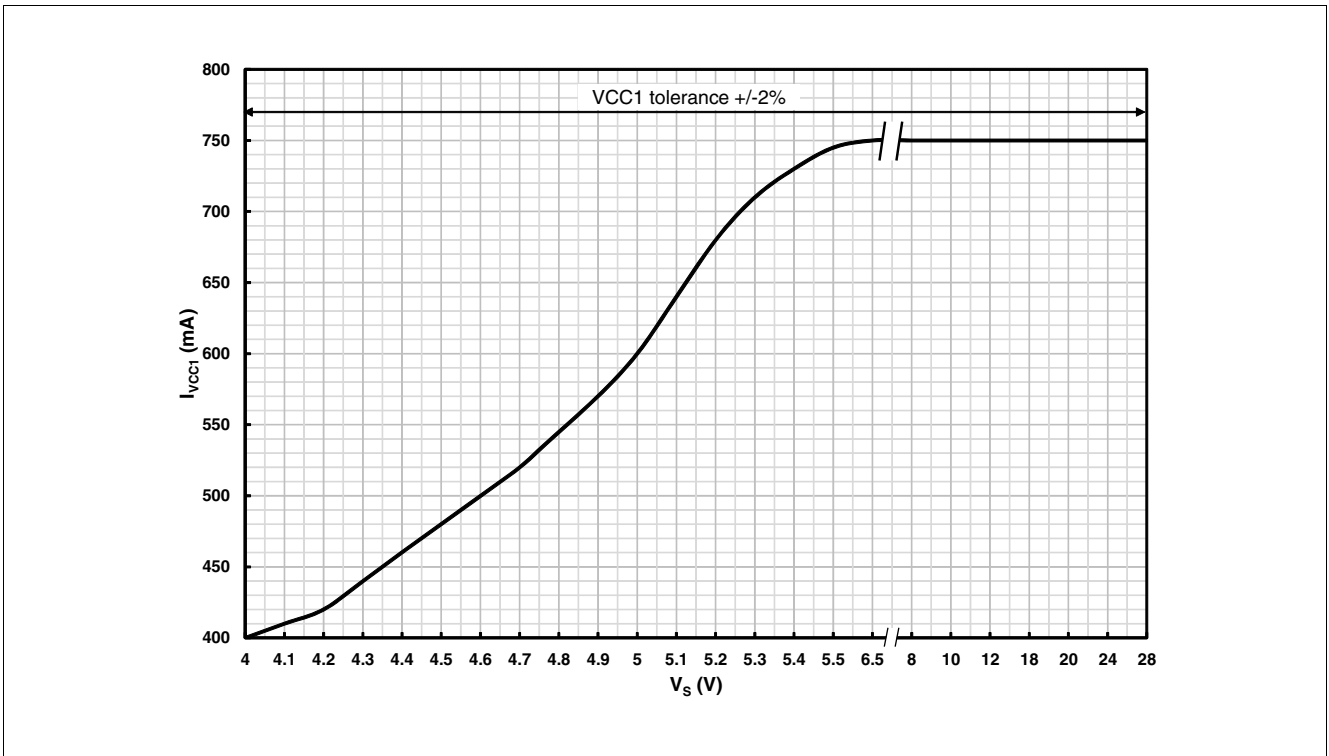

Figure 13 Maximum DCDC Buck current capability versus V_s

Note: **Figure 13** is based on characterization results overtemperature with external components specified in **Chapter 14.1**.

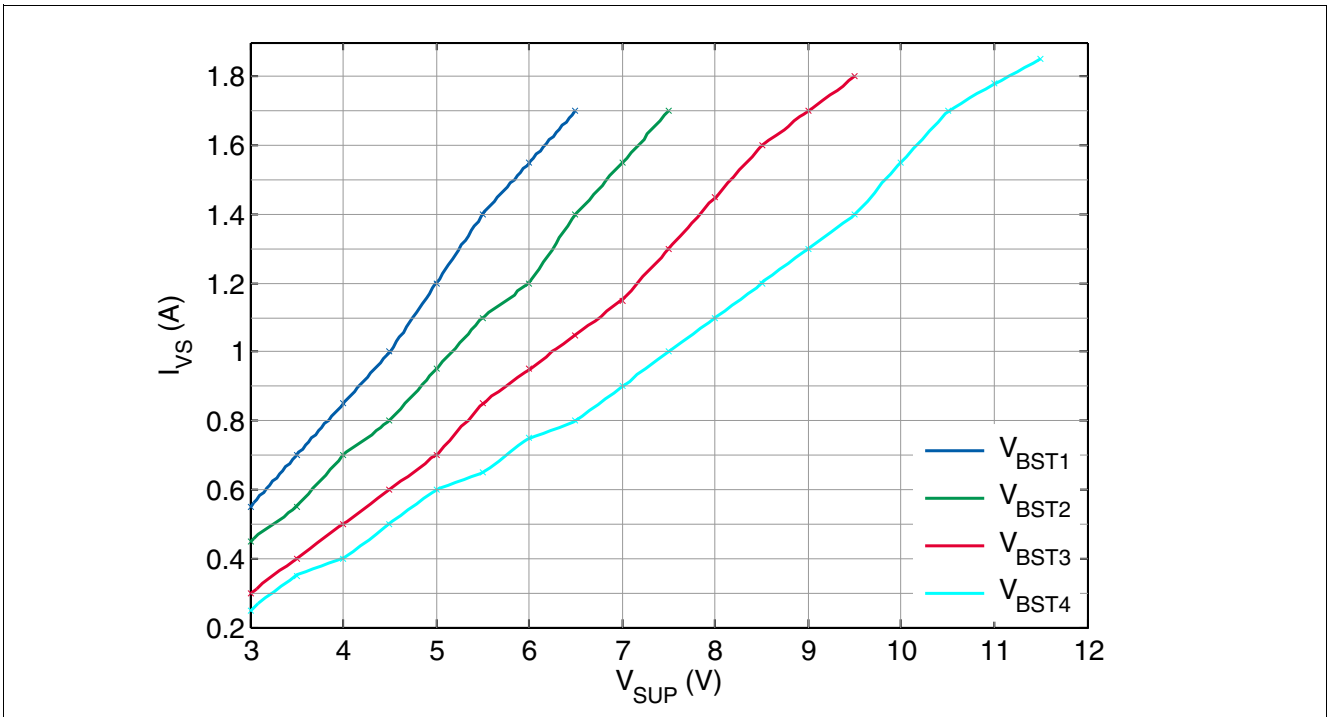

Figure 14 Maximum DCDC Boost current capability versus V_{SUP}

Note: **Figure 14** is based on simulation results (specified by design), with Boost converter external components specified in **Chapter 14.1**.

7 External Voltage Regulator

7.1 Block Description

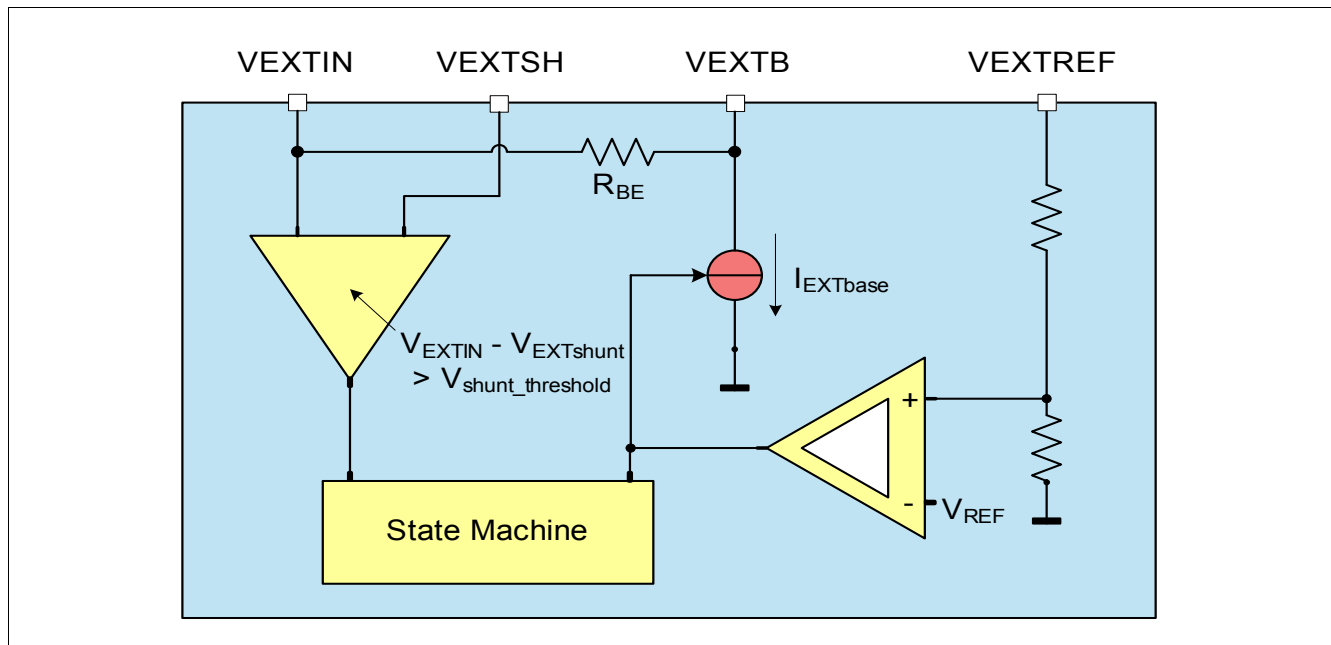

Figure 15 Functional Block Diagram

Functional Features

- Low-drop voltage regulator with external PNP transistor (up to 400 mA with 470 mΩ shunt resistor).
- Four high voltage pins are used: VEXTIN, VEXTB, VEXTSH, VEXTREF.
- Dedicated supply input VEXTIN to supply from V_S or from VCC1 (Buck regulator output voltage) depending on the application.
- Configurable output voltages via SPI: 5.0 V, 3.3 V (default), 1.8 V and 1.2 V.
- $\geq 4.7 \mu\text{F}$ ceramic capacitor at output voltage for stability, with $\text{ESR} < 150 \text{ m}\Omega$ @ $f = 10 \text{ kHz}$ to achieve the voltage regulator control loop stability based on the safe phase margin (bode diagram).
- Overcurrent limitation can be configured with external shunt resistor.

External Voltage Regulator

7.2 General Description

The external voltage regulator is used as an independent voltage regulator. The **VEXT_VCFG** in **HW_CTRL_1** register set the VEXT output voltage. The **VEXT_ON** in the **M_S_CTRL** register in SBC Normal Mode activates the VEXT voltage regulator.

The regulator will act in the respective SBC Mode as described in **Table 11**.

The maximum current **I_{EXT_max}** is defined by the shunt used. To protect the VEXT against overtemperature condition, the base driver has a dedicate temperature sensor. For detailed temperature protection features, refer to **Chapter 12.11**.

The status of VEXT is reported in the **SUP_STAT_1** register (for detailed protection features refer to **Chapter 12.10**).

Table 11 External Voltage Regulator State by SBC Mode

SBC Mode	Voltage Regulator Behavior
INIT Mode	OFF
Normal Mode	Configurable
Stop Mode	Fixed
Sleep Mode	Fixed
Restart Mode	Fixed
Fail-Safe Mode	OFF

*Note: The configuration of the VEXT voltage regulator behavior must be implemented immediately when the SBC Normal Mode is reached after power-up of the device. As soon as the bit **VEXT_ON** is set for the first time, the configuration for VEXT cannot be changed anymore. The configuration cannot be changed as long as the device is supplied.*

*Note: If the VEXT output voltage is supplying external off-board loads, the application must consider the series resonance circuit built by cable inductance and decoupling capacitor at load. Sufficient damping must be provided(e.g. series resistor with capacitor directly at device or 100 Ω Resistor between PNP collector and VEXTREF with 10 µF cap on collector (see **Figure 16**).*

7.2.1 Functional Description

This regulator offers with VEXT a second supply which could be used as off-board supply e.g. for sensors due to the integrated HV pins VEXTB, VEXTSH, VEXTREF.

External Voltage Regulator

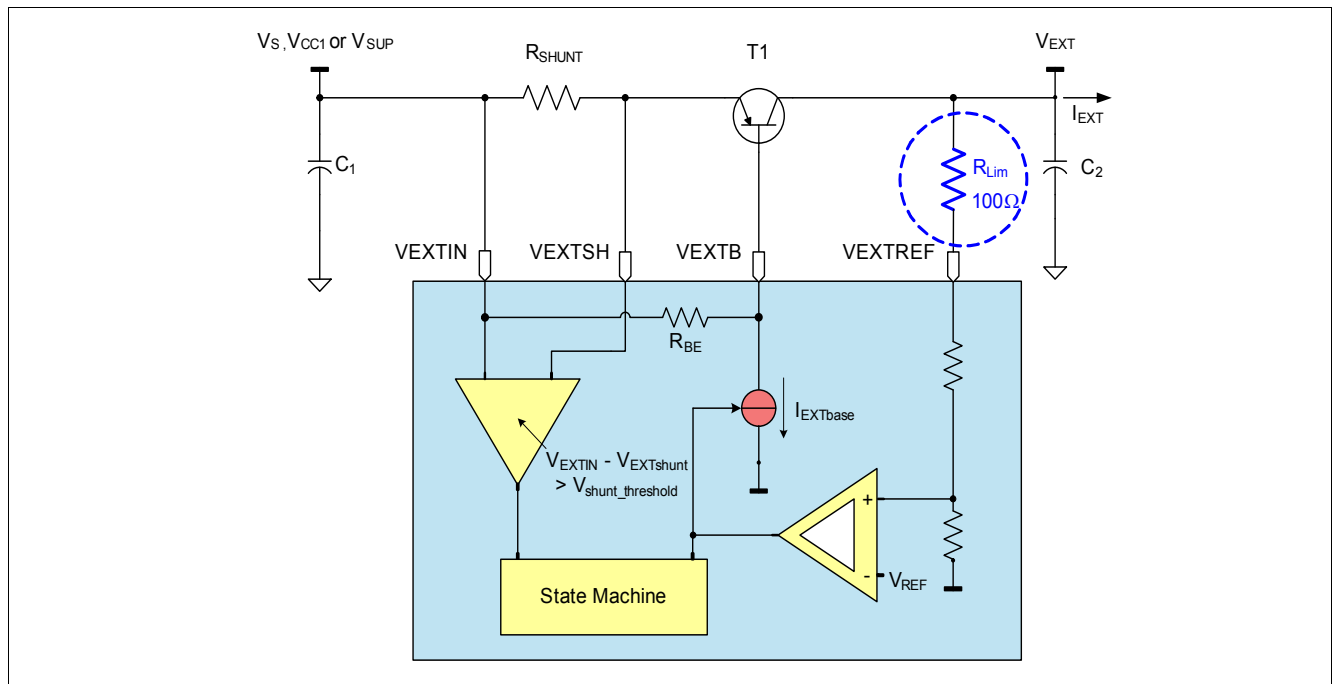

Figure 16 VEXT Hardware Setup

VEXT can be switched ON or OFF but the output voltage configuration cannot no longer be changed once activated.

An overcurrent detection function is realized with the external shunt (see Chapter 7.4 for calculating the desired shunt value) and output current shunt voltage threshold ($V_{shunt_threshold}$). When this threshold is reached, I_{EXT} is limited and only the overcurrent detection bit **VEXT_OC** is set (no other reactions). This bit can be cleared via SPI once the overcurrent condition is no longer present. If the overcurrent detection feature is not needed, connect the VEXTSH pin to VEXT supply (VEXTIN pin).

If the VEXT is enabled, an undervoltage event is signaled with the bit **VREG_UV** in the **SUP_STAT_0** register.

7.3 External Components

The characterization is done with the BCP52-16 from Infineon ($I_{EXT} < 200$ mA) and with MJD253 from ON Semi. Other PNP transistors can be used. The functionality must be checked in the application.

Figure 16 shows the hardware set up used.

Table 12 Bill of Materials for VEXT with BCP52-16

Device	Vendor	Reference / Value
C2	Murata	10 μ F/10V GCM31CR71A106K64L
RSHUNT	–	1 Ω
T1	Infineon	BCP52-16

Note: The SBC is not able to ensure a thermal protection of the external PNP transistor. The power handling capabilities for the application must therefore be chosen according to the selected PNP device and according to the PCB layout and the properties of the application to prevent thermal damage.

External Voltage Regulator

Table 13 Bill of Materials for VEXT with MJD-253

Device	Vendor	Reference / Value
C2	Murata	10 μF/10V GCM31CR71A106K64L
RSHUNT	–	470 mΩ
T1	ON-Semi	MJD253

7.4 Calculation of R_{SHUNT}

The maximum current I_{EXT_max} where the overcurrent detection bit is set (**VEXT_OC** = 1 on the **SUP_STAT_1** register), is determined by the shunt resistor R_{SHUNT} and the Output Current Shunt Voltage Threshold ($V_{shunt_threshold}$).

The resistor can be calculated as following:

$$R_{SHUNT} = \frac{V_{shunt_threshold}}{I_{EXT_max}} \quad (7.1)$$

7.5 Unused Pins

In case the VEXT is not used in the application, connect the unused pins of VEXT as followed:

- Connect VEXTSH, VEXTIN to V_S or leave open.
- Leave VEXTB open.
- Leave VEXTREF open.
- Keep VEXT disabled.

External Voltage Regulator

7.6 Electrical Characteristics

Table 14 Electrical Characteristics

$V_S = 5.5 \text{ V to } 28 \text{ V}$; $T_j = -40^\circ\text{C to } +150^\circ\text{C}$; SBC Normal Mode; all outputs open; all voltages with respect to ground; positive current defined flowing into pin (unless otherwise specified)

Parameter	Symbol	Values			Unit	Note or Test Condition	Number
		Min.	Typ.	Max.			
Parameters independent from Test Set-up							
External Regulator Control Drive Current Capability	I_{EXTbase}	40	60	80	mA	$V_{\text{EXTbase}} = 13.5 \text{ V}$	P_7.6.1
Input Current V_{EXTref}	I_{EXTref}	–	3	10	μA	$V_{\text{EXTref}} = 3.3 \text{ V}, 5 \text{ V}, 1.8 \text{ V}, 1.2 \text{ V}$	P_7.6.2
Input Current V_{EXT} Shunt Pin	I_{EXTshunt}	1	3	10	μA	$V_{\text{EXTshunt}} = V_S$	P_7.6.3
Output Current Shunt Voltage Threshold	$V_{\text{shunt_threshold}}$	180	245	310	mV	¹⁾	P_7.6.4
Leakage current of V_{EXTbase} when VEXT disabled	$I_{\text{EXTbase_lk}}$	–	–	5	μA	$V_{\text{EXTbase}} = V_S$; $T_j = 25^\circ\text{C}$	P_7.6.7
Leakage current of V_{EXTshunt} when VEXT disabled	$I_{\text{EXTshunt_lk}}$	–	–	5	μA	$V_{\text{EXTshunt}} = V_S$; $T_j = 25^\circ\text{C}$	P_7.6.25
Base to emitter resistor	R_{BE}	120	150	185	k Ω	$V_{\text{EXTbase}} = V_S - 0.3 \text{ V}$; $V_{\text{EXT}} \text{ OFF}$	P_7.6.9
Active Peak Threshold VEXT (Transition threshold between high-power and low-power mode regulator)	$I_{\text{VEXT,ipeak,r}}$	–	50	–	μA	²⁾ Drive current $I_{\text{-EXTbase}}$; I_{EXTbase} rising $V_S = 13.5 \text{ V}$; $-40^\circ\text{C} < T_j < 150^\circ\text{C}$	P_7.6.26
Active Peak Threshold VEXT (Transition threshold between high-power and low-power mode regulator)	$I_{\text{VEXT,ipeak,f}}$	–	30	–	μA	²⁾ Drive current $I_{\text{-EXTbase}}$; I_{EXTbase} falling $V_S = 13.5 \text{ V}$; $-40^\circ\text{C} < T_j < 150^\circ\text{C}$	P_7.6.27
Parameters dependent on the Test Set-up (with external PNP device MJD-253)							
External Regulator Output Voltage including Line and Load regulation	$V_{\text{EXT,out1}}$	4.9	5	5.1	V	³⁾ SBC Normal Mode; VEXT_VCFG=00_B $5.5 \text{ V} < V_{\text{INEXT}} < 28 \text{ V}$ $10 \text{ mA} < I_{\text{EXT}} < 400 \text{ mA}$;	P_7.6.10

External Voltage Regulator

Table 14 Electrical Characteristics (cont'd)

$V_S = 5.5\text{ V to }28\text{ V}$; $T_j = -40^\circ\text{C to }+150^\circ\text{C}$; SBC Normal Mode; all outputs open; all voltages with respect to ground; positive current defined flowing into pin (unless otherwise specified)

Parameter	Symbol	Values			Unit	Note or Test Condition	Number
		Min.	Typ.	Max.			
External Regulator Output Voltage including Line and Load regulation	$V_{EXT,out2}$	4.8	5	5.2	V	³⁾ SBC Stop, Sleep Mode; VEXT_VCFG=00_B $5.5\text{ V} < V_{INEXT} < 28\text{ V}$ $10\ \mu\text{A} < I_{EXT} < 20\text{ mA}$;	P_7.6.21
External Regulator Output Voltage including Line and Load regulation	$V_{EXT,out3}$	3.23	3.3V	3.37	V	³⁾ SBC Normal Mode; VEXT_VCFG=01_B $5.5\text{ V} < V_{INEXT} < 28\text{ V}$ $10\text{ mA} < I_{EXT} < 300\text{ mA}$;	P_7.6.11
External Regulator Output Voltage including Line and Load regulation	$V_{EXT,out4}$	3.15	3.3V	3.45	V	³⁾ SBC Stop, Sleep Mode; VEXT_VCFG=01_B $5.5\text{ V} < V_{INEXT} < 28\text{ V}$ $10\ \mu\text{A} < I_{EXT} < 20\text{ mA}$;	P_7.6.12
External Regulator Output Voltage including Line and Load regulation	$V_{EXT,out5}$	1.75	1.8	1.85	V	³⁾ SBC Normal Mode; VEXT_VCFG=10_B $5.5\text{ V} < V_{INEXT} < 28\text{ V}$ $10\text{ mA} < I_{EXT} < 300\text{ mA}$;	P_7.6.13
External Regulator Output Voltage including Line and Load regulation	$V_{EXT,out6}$	1.7	1.8	1.9	V	³⁾ SBC Stop, Sleep Mode; VEXT_VCFG=10_B $5.5\text{ V} < V_{INEXT} < 28\text{ V}$ $10\ \mu\text{A} < I_{EXT} < 20\text{ mA}$;	P_7.6.14
External Regulator Output Voltage including Line and Load regulation	$V_{EXT,out7}$	1.16	1.2	1.24	V	³⁾ SBC Normal Mode; VEXT_VCFG=11_B $5.5\text{ V} < V_{INEXT} < 28\text{ V}$ $10\text{ mA} < I_{EXT} < 300\text{ mA}$;	P_7.2.22
External Regulator Output Voltage including Line and Load regulation	$V_{EXT,out8}$	1.15	1.2	1.25	V	³⁾ SBC Stop, Sleep Mode; VEXT_VCFG=11_B $5.5\text{ V} < V_{INEXT} < 28\text{ V}$ $10\ \mu\text{A} < I_{EXT} < 20\text{ mA}$;	P_7.6.23

- 1) Threshold at which the current limitation starts to operate.
- 2) Not subject to production test, specified by design.
- 3) Tolerance includes load regulation and line regulation.

8 High Speed CAN Transceiver

8.1 Block Description

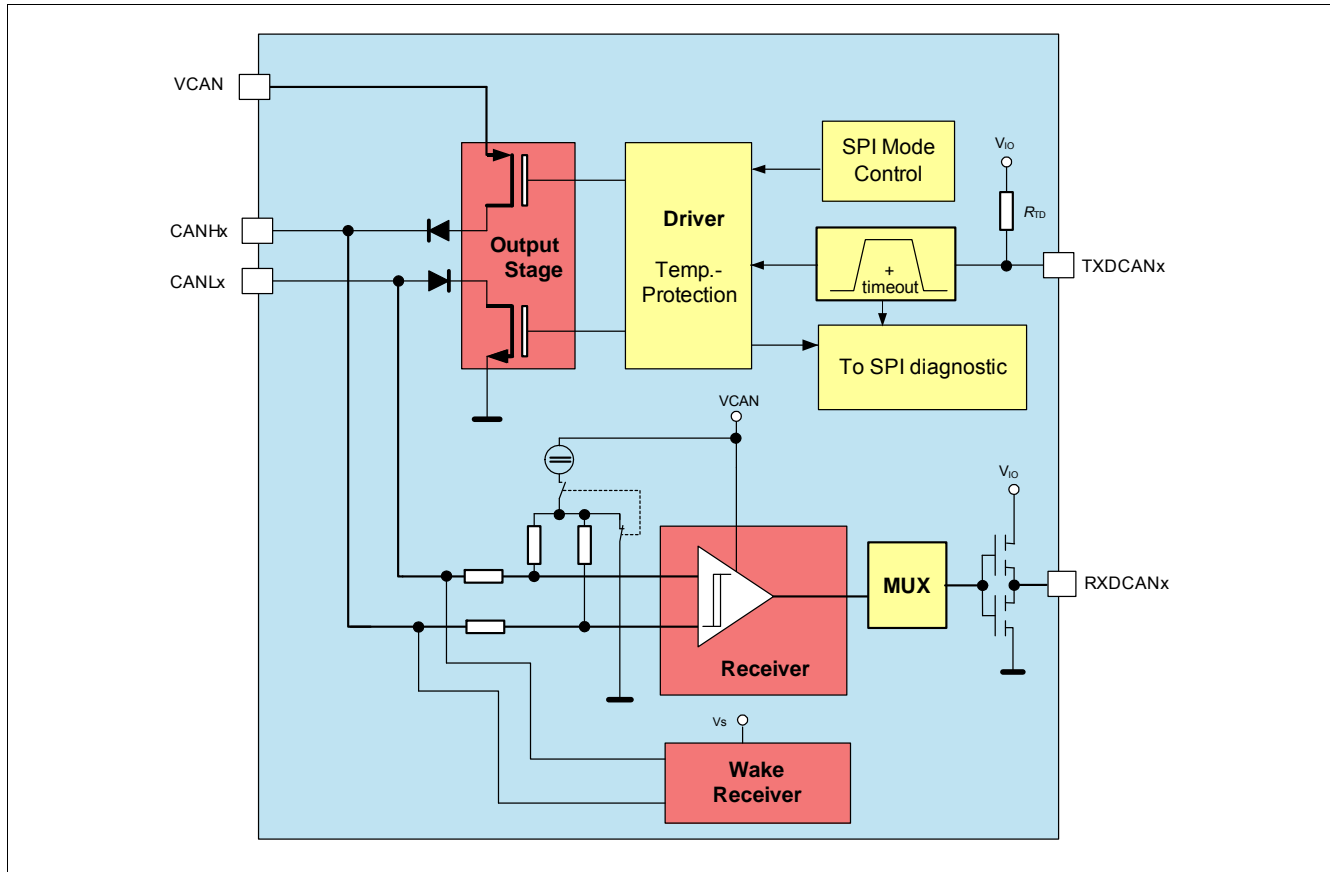

Figure 17 Functional Block Diagram

8.2 Functional Description

The Controller Area Network (CAN) transceiver part of the SBC provides high-speed (HS) differential mode data transmission (up to 5 Mb) and reception in automotive and industrial applications. It works as an interface between the CAN protocol controller and the physical bus lines compatible with ISO 11898-2, 11898-5 as well as SAE J2284.

The CAN transceiver offers low power modes to reduce current consumption. This supports networks with partially powered down nodes. To support software diagnostic functions, a CAN Receive-only Mode is implemented.

It is designed to provide excellent passive behavior when the transceiver is switched off (mixed networks, clamp15/30 applications).

A wake-up from the CAN wake capable mode is possible via a message on the bus. Thus, the microcontroller can be powered down or idled and will be woken up by the CAN bus activities.

The CAN transceiver is designed to withstand the severe conditions of automotive applications and to support 12 V applications.

The different transceiver modes can be controlled via the SPI CANx bits.

Figure 18 shows the possible transceiver mode transitions when changing the SBC mode.

High Speed CAN Transceiver

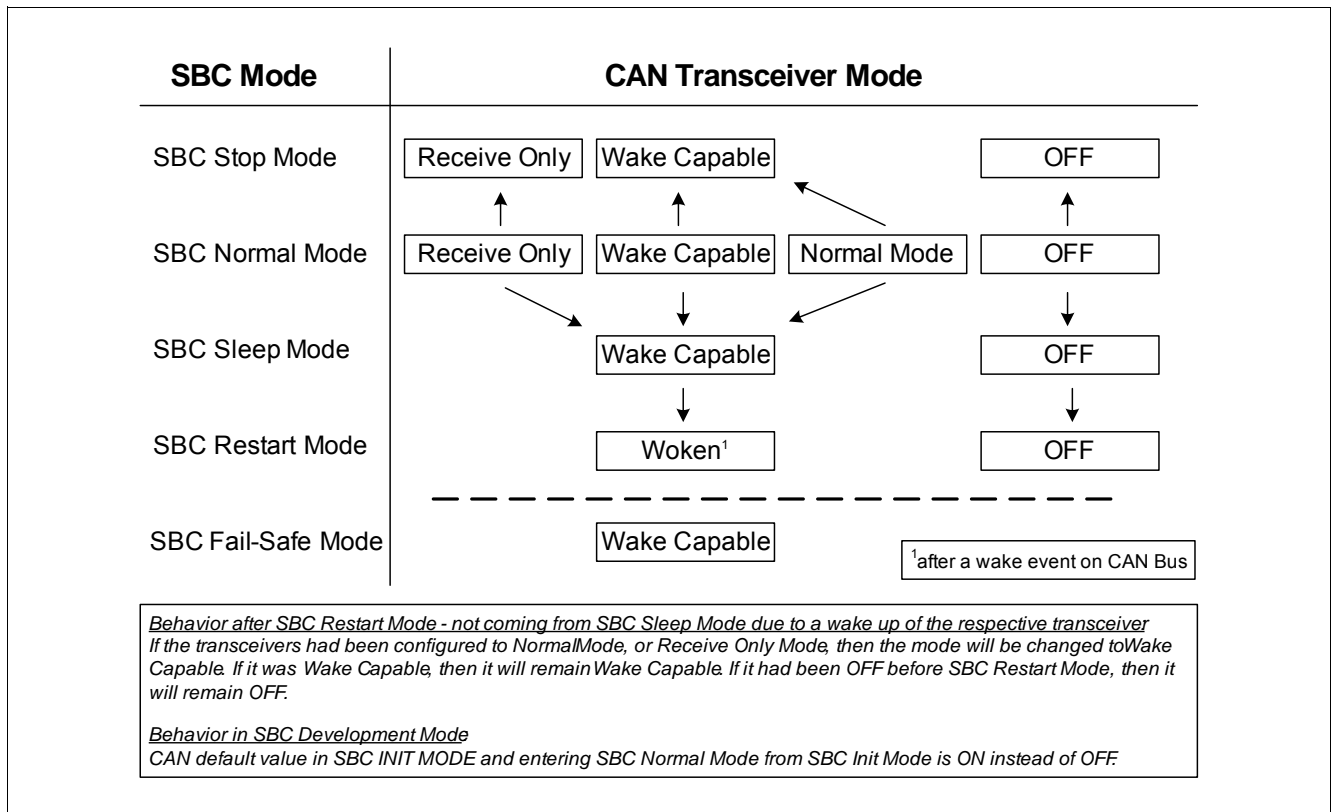

Figure 18 CAN Mode Control Diagram

CAN FD Support

CAN FD stands for ‘CAN with Flexible Data Rate’. It is based on the well established CAN protocol as specified in ISO 11898-1. CAN FD still uses the CAN bus arbitration method. The benefit is that the bit rate can be increased by switching to a shorter bit time at the end of the arbitration process and then returning to the longer bit time at the CRC delimiter before the receivers transmit their acknowledge bits. See also [Figure 19](#). In addition, the effective data rate is increased by allowing longer data fields. CAN FD allows the transmission of up to 64 data bytes compared to the 8 data bytes from the standard CAN.

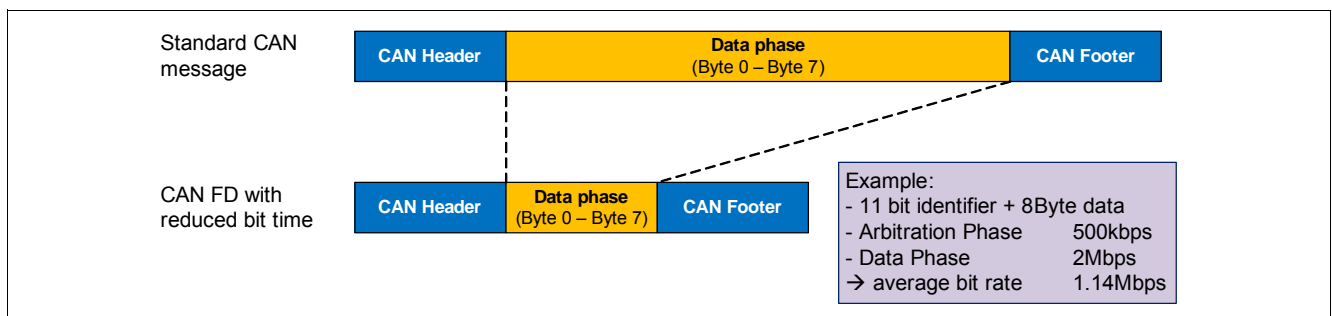

Figure 19 Bit Rate Increase with CAN FD vs. Standard CAN

CAN FD has to be supported by both the physical layer and the CAN controller. If the CAN controller cannot support CAN FD, then the respective CAN node must at least tolerate CAN FD communication. This CAN FD tolerant mode is implemented in the physical layer.

High Speed CAN Transceiver

8.2.1 CAN OFF Mode

The CAN OFF Mode is the default mode after power-up of the SBC. It is available in all SBC Modes and is intended to completely stop CAN activities or when CAN communication is not needed. The CANH/L bus interface acts as a high impedance input with a very small leakage current. In CAN OFF Mode, a wake-up event on the bus will be ignored.

8.2.2 CAN Normal Mode

The CAN Transceiver is enabled via SPI in SBC Normal Mode. CAN Normal Mode is designed for normal data transmission/reception within the HS-CAN network. The mode is only available in SBC Normal Mode or SBC Init Mode if the SBC Software Development Mode is used. The bus biasing is set to VCAN/2.

Transmission

The signal from the microcontroller is applied to the TXDCANx input of the SBC. The bus driver switches the CANH/L output stages to transfer this input signal to the CAN bus lines.

Enabling sequence

The CAN transceiver requires an enabling time $t_{CAN,EN}$ before a message can be sent on the bus. This means that the TXDCANx signal can only be pulled LOW after the enabling time. If this is not ensured, then the TXDCANx needs to be set back to HIGH (=recessive) until the enabling time is completed. Only the next dominant bit will be transmitted on the bus. **Figure 20** shows different scenarios and explanations for CAN enabling.

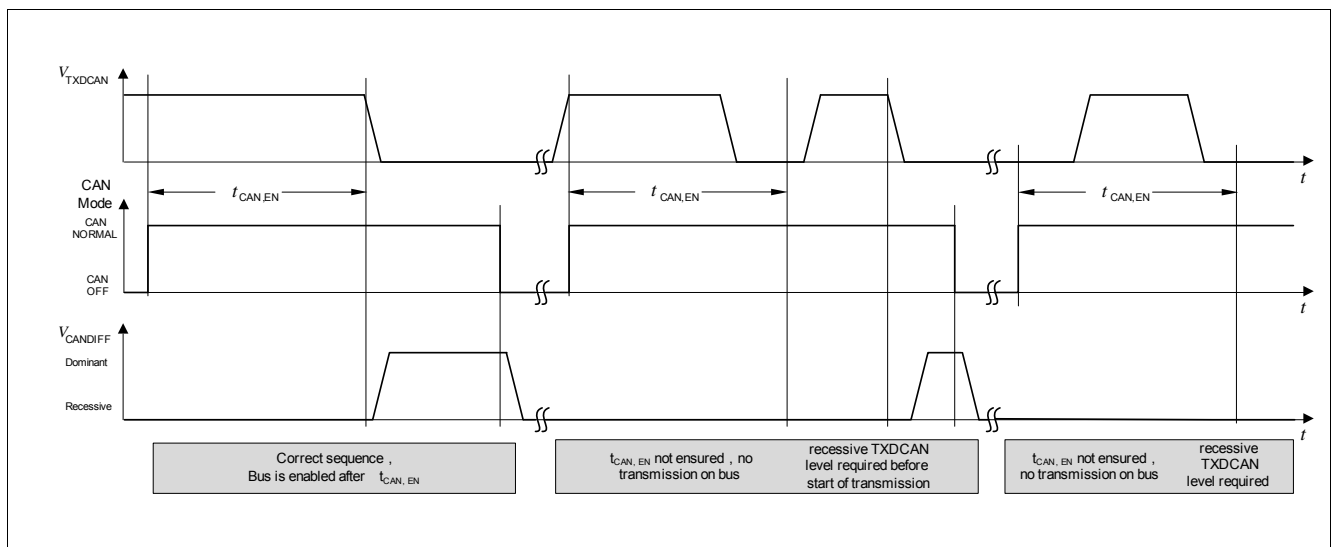

Figure 20 CAN Transceiver Enabling Sequence

Reduced Electromagnetic Emission

To reduce electromagnetic emissions (EME), the bus driver controls CANH/L slopes symmetrically. The slope control can be disabled using the CAN_x_Flash bits to achieve bite rate higher than 5 Mb.

Reception

Analog CAN bus signals are converted into digital signals at RXDCANx via the differential input receiver.

8.2.3 CAN Receive Only Mode

In CAN Receive Only Mode (RXD only), the driver stage is de-activated but reception is still operational. This mode is available in SBC Normal and Stop Mode. The bus biasing is set to VCAN/2.

High Speed CAN Transceiver

8.2.4 CAN Wake Capable Mode

This mode can be used in SBC Stop, Sleep, Restart and Normal Mode and it is used to monitor bus activities. It is automatically accessed in SBC Fail-Safe Mode. A valid wake-up pattern (WUP) on the bus results in a change of behavior of the SBC, as described in Table 15. As a signalization to the microcontroller, the RXDCANx pin is set LOW and will stay LOW until the CANx transceiver is changed to any other mode. After a wake-up event, the transceiver can be switched to CAN Normal Mode for communication using SPI command.

As shown in Figure 21, a wake-up pattern is signaled on the bus by two consecutive dominant bus levels for at least t_{Wake1} (filter time $t > t_{Wake1}$), each separated by a recessive bus level of less than t_{Wake2} .

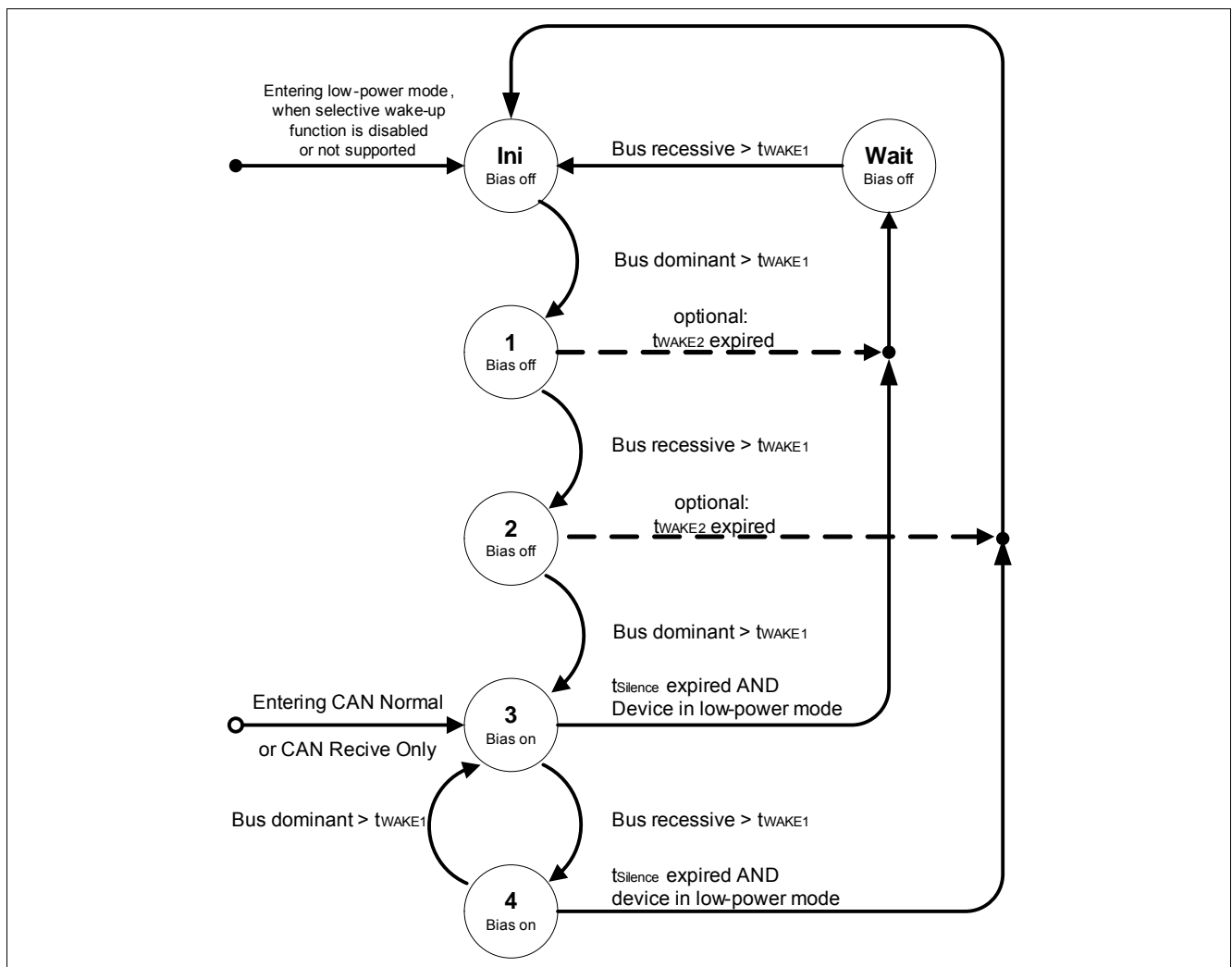

Figure 21 WUP detection following the definition in ISO 11898-5

Rearming the Transceiver for Wake Capability

After a bus wake-up event, the transceiver is woken. However, the CANx transceiver mode bits will still show wake capable (=‘01’) so that the RXDCAN signal will be pulled low. There are two possibilities how the CAN transceiver’s wake capable mode is enabled again after a wake event:

- The CAN transceiver mode must be toggled, i.e. switched from Wake Capable Mode to CAN Normal Mode, CAN Receive Only Mode or CAN Off, before switching to CAN Wake Capable Mode again.
- Rearming is done automatically when the SBC is changed to SBC Stop, Sleep, or SBC Fail-Safe Mode to ensure wake-up capability.

High Speed CAN Transceiver

Note: It is not necessary to clear the CAN wake-up bit CAN_x_WU to become wake capable again. It is sufficient to toggle the CAN mode.

Wake-Up in SBC Stop and Normal Mode

In SBC Stop Mode, if a wake-up is detected, it is always signaled by the INTN output and in the [WK_STAT_0](#), [WK_STAT_2](#) SPI registers. It is also signaled by RXDCANx pulled to low. The same applies for the SBC Normal Mode. The microcontroller should set the device from SBC Stop Mode to SBC Normal Mode; there is no automatic transition to SBC Normal Mode.

For functional safety reasons, the watchdog will be automatically enabled in SBC Stop Mode after a bus wake event in case it was disabled before (if bit [WD_EN_WK_BUS](#) was configured to HIGH before).

Wake-Up in SBC Sleep Mode

Wake-up is possible via a CAN message (filter time $t > t_{Wake1}$). The wake-up automatically transfers the SBC into the SBC Restart Mode and from there to Normal Mode the corresponding RXDCANx pin is set to LOW. The microcontroller is able to detect the low signal on RXDCANx and to read the wake source out of the [WK_STAT_0](#) or [WK_STAT_2](#) register via SPI. No interrupt is generated when coming out of SBC Sleep Mode. The microcontroller can now for example switch the CAN transceiver into CAN Normal Mode via SPI to start communication.

Table 15 Action due to CAN Bus Wake-Up

SBC Mode	SBC Mode after Wake	VCC1	INTN	RXD
Normal Mode	Normal Mode	ON	LOW	LOW
Stop Mode	Stop Mode	ON	LOW	LOW
Sleep Mode	Restart Mode	Ramping Up	HIGH	LOW
Restart Mode	Restart Mode	ON	HIGH	LOW
Fail-Safe Mode	Restart Mode	Ramping up	HIGH	LOW

8.2.5 TXD Time-out Feature

If the TXDCANx signal is dominant for a time $t > t_{TXD_CAN_TO}$, in CAN Normal Mode, the TXD time-out function deactivates the transmission of the signal at the bus. This is implemented to prevent the bus from being blocked permanently due to an error. The transmitter is disabled and the transceiver is switched to Receive Only Mode. The failure is stored in the SPI flag CAN_x_FAIL. The CAN transmitter stage is activated again after the dominant time-out condition is removed and the transceiver is automatically switched back to CAN Normal Mode. The transceiver configuration stays unchanged.

8.2.6 Bus Dominant Clamping

If the HS-CAN bus signal is dominant for a time $t > t_{BUS_CAN_TO}$, regardless of the CAN transceiver mode a bus dominant clamping is detected and the SPI bit CAN_x_FAIL is set. The transceiver configuration stays unchanged.

8.2.7 Undervoltage Detection

The voltage at the CAN supply pin is monitored in CAN Normal Mode and CAN Receiver Only Mode. In case of VCAN undervoltage, the bit [VCAN_UV](#) is set and the SBC disables the transmitter stage. If the undervoltage condition is not present anymore ($VCAN > V_{CAN_UV,t}$), the transceiver is automatically switched back to CAN Normal Mode. The transceiver configuration stays unchanged.

High Speed CAN Transceiver

8.3 Electrical Characteristics

Table 16 Electrical Characteristics

$V_S = 5.5 \text{ V to } 28 \text{ V}$; $T_j = -40^\circ\text{C to } +150^\circ\text{C}$; $4.75 \text{ V} < V_{\text{CAN}} < 5.25 \text{ V}$; $R_L = 60 \ \Omega$; CAN Normal Mode; all voltages with respect to ground, positive current flowing into pin (unless otherwise specified)

Parameter	Symbol	Values			Unit	Note or Test Condition	Number
		Min.	Typ.	Max.			
CAN Supply Voltage							
CAN Supply undervoltage detection threshold	$V_{\text{CAN_UV,f}}$	4.5	–	4.75	V	CAN Normal Mode; VCAN falling;	P_8.3.1
CAN Bus Receiver							
Differential Receiver Threshold Voltage, recessive to dominant edge	$V_{\text{diff,rd_N}}$	–	0.80	0.90	V	$V_{\text{diff}} = V_{\text{CANH}} - V_{\text{CANL}}$; $-12 \text{ V} \leq V_{\text{CM}}(\text{CAN}) \leq +12 \text{ V}$; CAN Normal Mode	P_8.3.2
Dominant state differential input voltage range	$V_{\text{diff_D_range}}$	0.9	–	8.0	V	$V_{\text{diff}} = V_{\text{CANH}} - V_{\text{CANL}}$; $-12 \text{ V} \leq V_{\text{CM}}(\text{CAN}) \leq +12 \text{ V}$; CAN Normal Mode	P_8.3.60
Differential Receiver Threshold Voltage, dominant to recessive edge	$V_{\text{diff,dr_N}}$	0.50	0.60	–	V	$V_{\text{diff}} = V_{\text{CANH}} - V_{\text{CANL}}$; $-12 \text{ V} \leq V_{\text{CM}}(\text{CAN}) \leq +12 \text{ V}$; CAN Normal Mode	P_8.3.3
Recessive state differential input voltage range	$V_{\text{diff_R_range}}$	-3.0	–	0.5	V	$V_{\text{diff}} = V_{\text{CANH}} - V_{\text{CANL}}$; $-12 \text{ V} \leq V_{\text{CM}}(\text{CAN}) \leq +12 \text{ V}$; CAN Normal Mode	P_8.3.61
Common Mode Range	CMR	-12	–	12	V	¹⁾	P_8.3.4
CANH, CANL Input Resistance	R_i	20	40	50	k Ω	CAN Normal / Wake capable Mode; $-2 \text{ V} \leq V_{\text{CANH/L}} \leq +7 \text{ V}$ Recessive state	P_8.3.5
Differential Input Resistance	R_{diff}	40	80	100	k Ω	CAN Normal / Wake capable Mode; $-2 \text{ V} \leq V_{\text{CANH/L}} \leq +7 \text{ V}$ Recessive state	P_8.3.6
Input Resistance Deviation between CANH and CANL	DR_i	-3	–	3	%	¹⁾ Recessive state $V_{\text{CANH}} = V_{\text{CANL}} = 5 \text{ V}$	P_8.3.7
Input Capacitance CANH, CANL versus GND	C_{in}	–	20	40	pF	¹⁾ $V_{\text{TXD}} = 5 \text{ V}$	P_8.3.8
Differential Input Capacitance	C_{diff}	–	10	20	pF	¹⁾ $V_{\text{TXD}} = 5 \text{ V}$	P_8.3.9

High Speed CAN Transceiver

Table 16 Electrical Characteristics (cont'd)

$V_S = 5.5\text{ V to }28\text{ V}$; $T_j = -40^\circ\text{C to }+150^\circ\text{C}$; $4.75\text{ V} < V_{\text{CAN}} < 5.25\text{ V}$; $R_L = 60\ \Omega$; CAN Normal Mode; all voltages with respect to ground, positive current flowing into pin (unless otherwise specified)

Parameter	Symbol	Values			Unit	Note or Test Condition	Number
		Min.	Typ.	Max.			
Wake-up Receiver Threshold Voltage, recessive to dominant edge	$V_{\text{diff,rd}_W}$	–	0.8	1.15	V	$-12\text{ V} \leq V_{\text{CM}}(\text{CAN}) \leq +12\text{ V}$; CAN Wake Capable Mode	P_8.3.10
Wake-up Receiver Dominant state differential input voltage range	$V_{\text{diff,D_range}_W}$	1.15	–	8.0	V	$-12\text{ V} \leq V_{\text{CM}}(\text{CAN}) \leq +12\text{ V}$; CAN Wake Capable Mode	P_8.3.62
Wake-up Receiver Threshold Voltage, dominant to recessive edge	$V_{\text{diff,dr}_W}$	0.4	0.7	–	V	$-12\text{ V} \leq V_{\text{CM}}(\text{CAN}) \leq +12\text{ V}$; CAN Wake Capable Mode	P_8.3.11
Wake-up Receiver Recessive state differential input voltage range	$V_{\text{diff,R_range}_W}$	-3.0	–	0.4	V	$-12\text{ V} \leq V_{\text{CM}}(\text{CAN}) \leq +12\text{ V}$; CAN Wake Capable Mode	P_8.3.63

CAN Bus Transmitter

CANH/CANL Recessive Output Voltage (CAN Normal Mode)	$V_{\text{CANL/H_NM}}$	2.0	–	3.0	V	CAN Normal Mode; $V_{\text{TXD}} = V_{\text{IO}}$; no load	P_8.3.12
CANH/CANL Recessive Output Voltage (CAN Wake Capable Mode)	$V_{\text{CANL/H_LP}}$	-0.1	–	0.1	V	CAN Wake Capable Mode; $V_{\text{TXD}} = V_{\text{IO}}$; no load	P_8.3.13
CANH, CANL Recessive Output Voltage Difference $V_{\text{diff}} = V_{\text{CANH}} - V_{\text{CANL}}$	$V_{\text{diff}_r_N}$	-500	–	50	mV	CAN Normal Mode $V_{\text{TXD}} = V_{\text{IO}}$; no load	P_8.3.14
CANH, CANL Recessive Output Voltage Difference $V_{\text{diff}} = V_{\text{CANH}} - V_{\text{CANL}}$	$V_{\text{diff}_r_W}$	-100	–	100	mV	CAN Wake Capable Mode; $V_{\text{TXD}} = V_{\text{IO}}$; no load	P_8.3.15
CANL Dominant Output Voltage	V_{CANL}	0.5	–	2.25	V	CAN Normal Mode; $V_{\text{TXD}} = 0\text{ V}$; $50\ \Omega \leq R_L \leq 65\ \Omega$	P_8.3.16
CANH Dominant Output Voltage	V_{CANH}	2.75	–	4.5	V	CAN Normal Mode; $V_{\text{TXD}} = 0\text{ V}$; $50\ \Omega \leq R_L \leq 65\ \Omega$	P_8.3.17
CANH, CANL Dominant Output Voltage Difference $V_{\text{diff}} = V_{\text{CANH}} - V_{\text{CANL}}$	$V_{\text{diff}_d_N}$	1.5	–	3.0	V	CAN Normal Mode; $V_{\text{TXD}} = 0\text{ V}$; $50\ \Omega \leq R_L \leq 65\ \Omega$	P_8.3.18

High Speed CAN Transceiver

Table 16 Electrical Characteristics (cont'd)

$V_S = 5.5 \text{ V to } 28 \text{ V}$; $T_j = -40^\circ\text{C to } +150^\circ\text{C}$; $4.75 \text{ V} < V_{\text{CAN}} < 5.25 \text{ V}$; $R_L = 60 \Omega$; CAN Normal Mode; all voltages with respect to ground, positive current flowing into pin (unless otherwise specified)

Parameter	Symbol	Values			Unit	Note or Test Condition	Number
		Min.	Typ.	Max.			
CANH, CANL Dominant Output Voltage Difference $V_{\text{diff}} = V_{\text{CANH}} - V_{\text{CANL}}$ on extended bus load range	$V_{\text{diff,d}_N}$	1.5	–	5.0	V	¹⁾ CAN Normal Mode; $V_{\text{TXD}} = 0 \text{ V}$; $R_L = 2240 \Omega$	P_8.3.58
CANH Short Circuit Current	I_{CANHsc}	-100	-80	-50	mA	CAN Normal Mode; $V_{\text{CANHshort}} = -3 \text{ V}$	P_8.3.20
CANL Short Circuit Current	I_{CANLsc}	50	80	100	mA	CAN Normal Mode $V_{\text{CANLshort}} = 18 \text{ V}$	P_8.3.21
Leakage Current (unpowered device)	$I_{\text{CANH,lk}}$ $I_{\text{CANL,lk}}$	–	5	7.5	μA	$V_S = V_{\text{CAN}} = 0 \text{ V}$; $0 \text{ V} < V_{\text{CANH,L}} \leq 5 \text{ V}$; ²⁾ $R_{\text{test}} = 0 / 47 \text{ k}\Omega$	P_8.3.22

Receiver Output RXD

HIGH level Output Voltage	$V_{\text{RXD,H}}$	$0.8 \times V_{\text{IO}}$	–	–	V	CAN Normal Mode $I_{\text{RXD(CAN)}} = -2 \text{ mA}$;	P_8.3.23
LOW Level Output Voltage	$V_{\text{RXD,L}}$	–	–	$0.2 \times V_{\text{IO}}$	V	CAN Normal Mode $I_{\text{RXD(CAN)}} = 2 \text{ mA}$;	P_8.3.24

Transmission Input TXD

HIGH Level Input Voltage Threshold	$V_{\text{TXD,H}}$	–	–	$0.7 \times V_{\text{IO}}$	V	CAN Normal Mode recessive state	P_8.3.25
LOW Level Input Voltage Threshold	$V_{\text{TXD,L}}$	$0.3 \times V_{\text{IO}}$	–	–	V	CAN Normal Mode dominant state	P_8.3.26
TXD Input Hysteresis	$V_{\text{TXD,hys}}$	–	$0.12 \times V_{\text{IO}}$	–	mV	¹⁾	P_8.3.27
TXD Pull-up Resistance	R_{TXD}	20	40	80	k Ω	–	P_8.3.28
CAN Transceiver Enabling Time	$t_{\text{CAN,EN}}$	8	13	18	μs	⁸⁾ CSN = HIGH to first valid transmitted TXD dominant	P_8.3.29

Dynamic CAN-Transceiver Characteristics

Driver Symmetry $V_{\text{SYM}} = V_{\text{CANH}} + V_{\text{CANL}}$	V_{SYM}	4.5	–	5.5	V	¹⁾³⁾ CAN Normal Mode; $V_{\text{TXD}} = 0 \text{ V} / 5 \text{ V}$; $V_{\text{CAN}} = 5 \text{ V}$; $C_{\text{SPLIT}} = 4.7 \text{ nF}$; $50 \Omega \leq R_L \leq 60 \Omega$	P_8.3.19
Min. Dominant Time for Bus Wake-up	t_{Wake1}	0.5	1.2	1.8	μs	$-12 \text{ V} \leq V_{\text{CM(CAN)}} \leq +12 \text{ V}$; CAN Wake capable Mode	P_8.3.30
Wake-up Time-out, Recessive Bus	t_{Wake2}	0.5	–	10	ms	⁸⁾ CAN Wake capable Mode	P_8.3.31

High Speed CAN Transceiver

Table 16 Electrical Characteristics (cont'd)

$V_S = 5.5\text{ V to }28\text{ V}$; $T_j = -40^\circ\text{C to }+150^\circ\text{C}$; $4.75\text{ V} < V_{\text{CAN}} < 5.25\text{ V}$; $R_L = 60\ \Omega$; CAN Normal Mode; all voltages with respect to ground, positive current flowing into pin (unless otherwise specified)

Parameter	Symbol	Values			Unit	Note or Test Condition	Number
		Min.	Typ.	Max.			
WUP Wake-up Reaction Time	$t_{\text{WU_WUP}}$	–	–	100	μs	⁴⁾⁵⁾⁸⁾ Wake-up reaction time after a valid WUP on CAN bus;	P_8.3.32
⁶⁾ ISO: Loop Delay (recessive to dominant)	$t_{\text{loop},f}$	–	150	255	ns	CAN Normal Mode $C_L = 100\text{ pF}$; $R_L = 60\ \Omega$; $C_{\text{RXD}} = 15\text{ pF}$ (see Figure 22)	P_8.3.33
⁶⁾ ISO: Loop Delay(dominant to recessive)	$t_{\text{loop},r}$	–	150	255	ns	CAN Normal Mode $C_L = 100\text{ pF}$; $R_L = 60\ \Omega$; $C_{\text{RXD}} = 15\text{ pF}$ (see Figure 22)	P_8.3.34
Propagation Delay TXD LOW to bus dominant	$t_{\text{d(L),T}}$	–	50	–	ns	CAN Normal Mode $C_L = 100\text{ pF}$; $R_L = 60\ \Omega$; (see Figure 22)	P_8.3.35
Propagation Delay TXD HIGH to bus recessive	$t_{\text{d(H),T}}$	–	50	–	ns	CAN Normal Mode $C_L = 100\text{ pF}$; $R_L = 60\ \Omega$; (see Figure 22)	P_8.3.36
Propagation Delay bus dominant to RXD LOW	$t_{\text{d(L),R}}$	–	100	–	ns	CAN Normal Mode $C_L = 100\text{ pF}$; $R_L = 60\ \Omega$; $C_{\text{RXD}} = 15\text{ pF}$ (see Figure 22)	P_8.3.37
Propagation Delay bus recessive to RXD HIGH	$t_{\text{d(H),R}}$	–	100	–	ns	CAN Normal Mode $C_L = 100\text{ pF}$; $R_L = 60\ \Omega$; $C_{\text{RXD}} = 15\text{ pF}$ (see Figure 22)	P_8.3.38
⁶⁾ Received Recessive bit width CAN FD up to 2 Mbps	$t_{\text{bit(RXD)}}$	400	–	550	ns	CAN Normal Mode $C_L = 100\text{ pF}$ $R_L = 60\ \Omega$ $C_{\text{RXD}} = 15\text{ pF}$ $t_{\text{bit(TXD)}} = 500\text{ ns}$ Parameter definition in according to Figure 23 .	P_8.3.45

High Speed CAN Transceiver

Table 16 Electrical Characteristics (cont'd)

$V_S = 5.5\text{ V to }28\text{ V}$; $T_j = -40^\circ\text{C to }+150^\circ\text{C}$; $4.75\text{ V} < V_{\text{CAN}} < 5.25\text{ V}$; $R_L = 60\ \Omega$; CAN Normal Mode; all voltages with respect to ground, positive current flowing into pin (unless otherwise specified)

Parameter	Symbol	Values			Unit	Note or Test Condition	Number
		Min.	Typ.	Max.			
⁶⁾ Transmitted Recessive bit width CAN FD up to 2 Mbps	$t_{\text{bit(BUS)}}$	435	–	530	ns	CAN Normal Mode $C_L = 100\text{ pF}$ $R_L = 60\ \Omega$ $C_{\text{RXD}} = 15\text{ pF}$ $t_{\text{bit(TXD)}} = 500\text{ ns}$ Parameter definition in according to Figure 23.	P_8.3.52
⁶⁾ Received Recessive bit width CAN FD up to 5 Mbps	$t_{\text{bit(RXD)}}$	120	–	220	ns	CAN Normal Mode $C_L = 100\text{ pF}$ $R_L = 60\ \Omega$ $C_{\text{RXD}} = 15\text{ pF}$ $t_{\text{bit(TXD)}} = 200\text{ ns}$ Parameter definition in according to Figure 23.	P_8.3.46
⁶⁾ Transmitted Recessive bit width CAN FD up to 5 Mbps	$t_{\text{bit(BUS)}}$	155	–	210	ns	CAN Normal Mode $C_L = 100\text{ pF}$ $R_L = 60\ \Omega$ $C_{\text{RXD}} = 15\text{ pF}$ $t_{\text{bit(TXD)}} = 200\text{ ns}$ Parameter definition in according to Figure 23.	P_8.3.53
Receiver timing symmetry ⁷⁾ CAN FD up to 2 Mbps	Δt_{Rec}	-65	–	40	ns	⁷⁾ CAN Normal Mode $C_L = 100\text{ pF}$ $R_L = 60\ \Omega$ $C_{\text{RXD}} = 15\text{ pF}$ $t_{\text{bit(TXD)}} = 500\text{ ns}$ Parameter definition according to Figure 23.	P_8.3.39
Receiver timing symmetry ⁷⁾ CAN FD up to 5 Mbps	Δt_{Rec}	-45	–	15	ns	⁷⁾ CAN Normal Mode $C_L = 100\text{ pF}$ $R_L = 60\ \Omega$ $C_{\text{RXD}} = 15\text{ pF}$ $t_{\text{bit(TXD)}} = 200\text{ ns}$ Parameter definition according to Figure 23.	P_8.3.43
TXD Permanent Dominant Time-out	$t_{\text{TXD_CAN_TO}}$	–	2	–	ms	⁸⁾ CAN Normal Mode	P_8.3.40

High Speed CAN Transceiver

Table 16 Electrical Characteristics (cont'd)

$V_S = 5.5\text{ V to }28\text{ V}$; $T_j = -40^\circ\text{C to }+150^\circ\text{C}$; $4.75\text{ V} < V_{CAN} < 5.25\text{ V}$; $R_L = 60\ \Omega$; CAN Normal Mode; all voltages with respect to ground, positive current flowing into pin (unless otherwise specified)

Parameter	Symbol	Values			Unit	Note or Test Condition	Number
		Min.	Typ.	Max.			
BUS Permanent Dominant Time-out	$t_{BUS_CAN_TO}$	–	2	–	ms	⁸⁾ CAN Normal Mode	P_8.3.41
Time-out for bus inactivity	$t_{SILENCE}$	0.6	–	1.2	s	⁸⁾	P_8.3.44

- 1) Not subject to production test, specified by design.
- 2) R_{test} between V_S/V_{CAN} and 0 V (GND).
- 3) V_{SYM} shall be observed during dominant and recessive state and also during the transition from dominant to recessive and vice versa while TxD is simulated by a square signal (50% duty cycle) a frequency of 1 MHz.
- 4) Wake-up is signalized via INTN pin activation in SBC Stop Mode and via VCC1 ramping up with wake from SBC Sleep Mode.
- 5) Time starts with end of last dominant phase of WUP.
- 6) Nomenclature refers to ISO 11898-2:2016.
- 7) $\Delta t_{Rec} = t_{bit(RXD)} - t_{bit(BUS)}$
- 8) Not subject to production test, tolerance defined by internal oscillator tolerance.

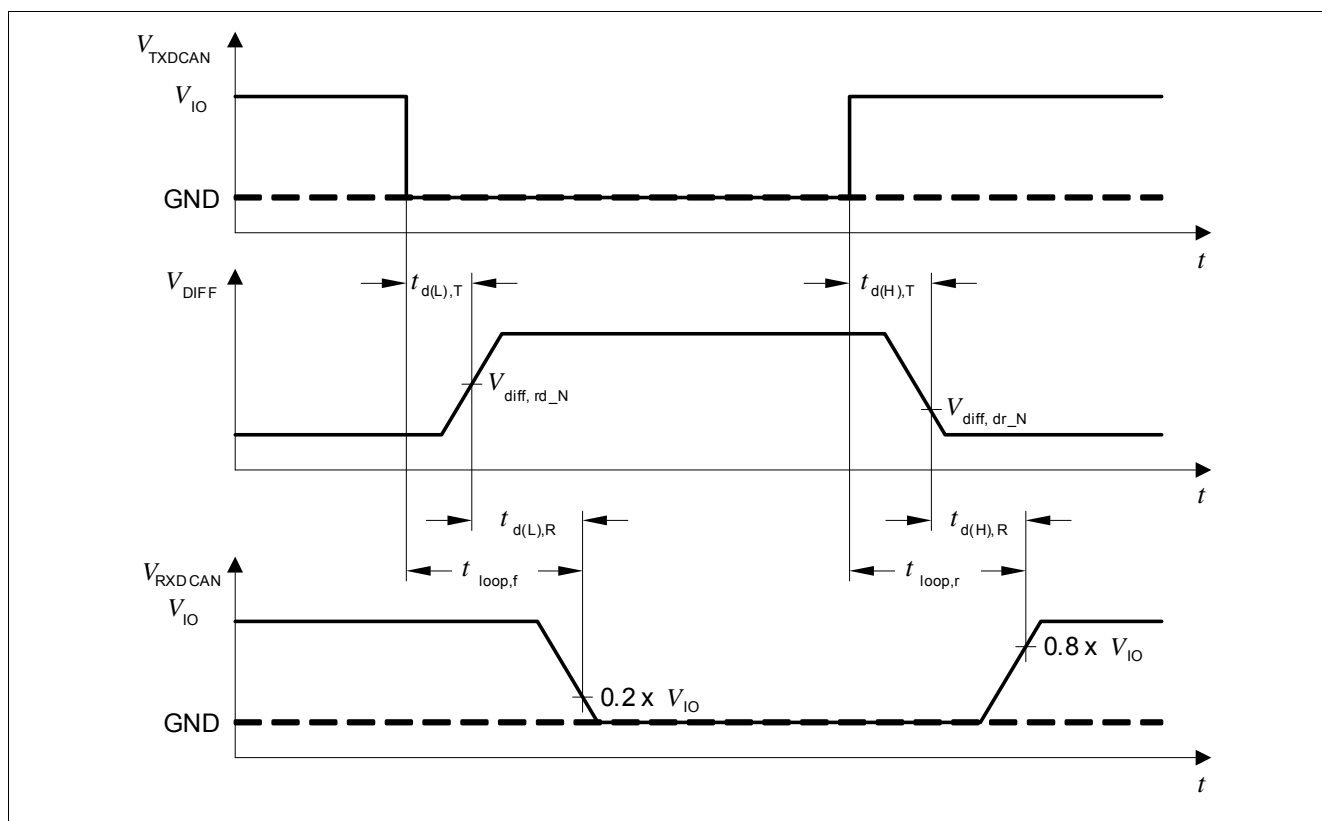

Figure 22 Timing Diagrams for Dynamic Characteristics

High Speed CAN Transceiver

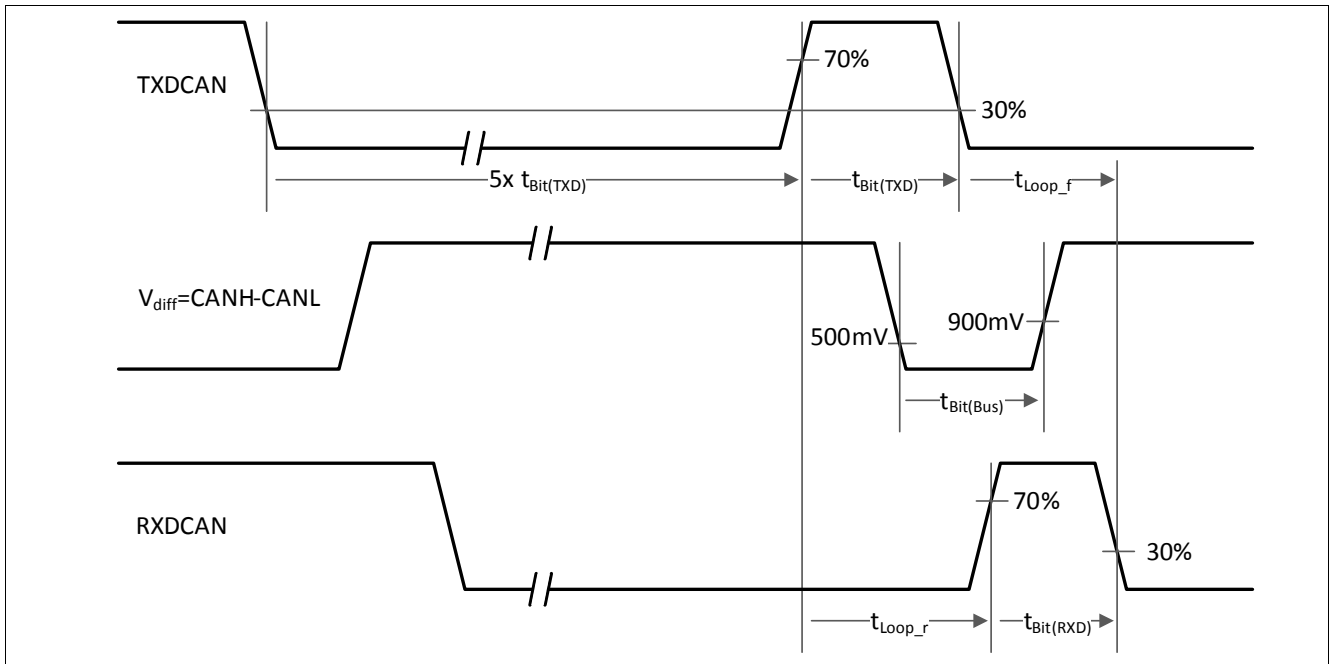

Figure 23 From ISO 11898-2: t_{Loop}, t_{Bit(TXD)}, t_{Bit(RXD)} Definition

Wake Input

9 Wake Input

9.1 Features

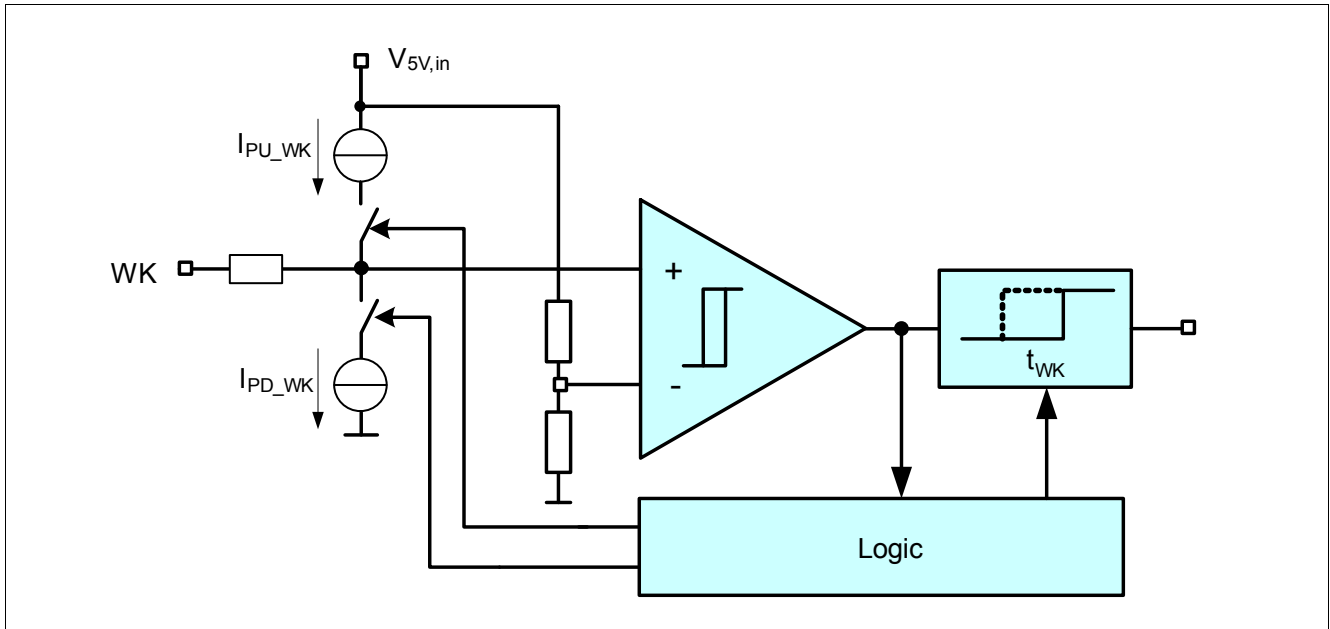

Figure 24 Wake Input Block Diagram

Features

- One HIGH-voltage inputs with V_{WKth} threshold voltage.
- Wake-up capability for power saving modes.
- Switch feature for DC/DC Mode (PFM/PWM) in SBC Stop Mode.
- Sensitive for level changes LOW to HIGH and HIGH to LOW.
- Pull-up and Pull-down current, selectable via SPI.
- In SBC Normal and Stop Mode, the WK pin level can be read via SPI.

9.2 Functional Description

The SBC can wake up following a voltage level change at the wake input. The WK input pin is sensitive to level changes. This means that both transitions, HIGH to LOW and LOW to HIGH, result in SBC signalling (see also [Figure 25](#)). The signal is created in one of the following ways:

- By triggering the interrupt in SBC Normal and SBC Stop Mode.
- By waking up the device in SBC Sleep and SBC Fail-Safe Mode.

Wake Input

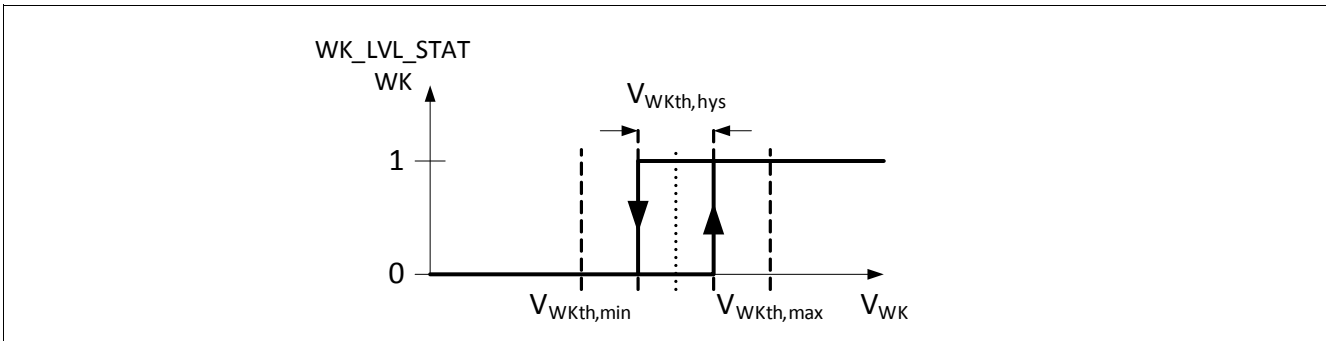

Figure 25 Wake Input Threshold Levels and Hysteresis

The wake-up capability, using WK pin, can be enabled or disabled via SPI command.

When the WK is enabled (**WK_EN** set to 1 on **WK_CTRL_1** register), the device wakes up from Sleep Mode with a HIGH to LOW or LOW to HIGH transition on the WK pin. In SBC Stop and Normal Mode, an Interrupt will be generated after t_{FWK} (filter time). In SBC Fail-Safe Mode, the WK is automatically selected as wake-up source and the device will always go to SBC Restart Mode with a HIGH to LOW or LOW to HIGH transition. The wake source for WK pin can be read in the register **WK_STAT_0** at the bit **WK_WU**. The state of the WK pin (LOW or HIGH) can always be read in SBC Normal and Stop Mode at the bit **WK** on register **WK_LVL_STAT**.

The WK pin can also be configured as a selection pin for PFM / PWM mode in SBC Stop Mode using the bit **PWM_BY_WK** of register **HW_CTRL_0**. In this case a LOW level at the WK pin will switch the Buck converter to PFM mode, a HIGH level will switch the Buck converter to PWM Mode maintaining the SBC in SBC Stop Mode. The filter time is not taken into account because a defined signal is expected (refer to **Chapter 6.2.2.2**).

In case that the **PWM_BY_WK** is used, it is still possible to use the WK pin to wake-up from SBC Sleep Mode to SBC Normal Mode.

Figure 26 shows a typical wake-up timing:

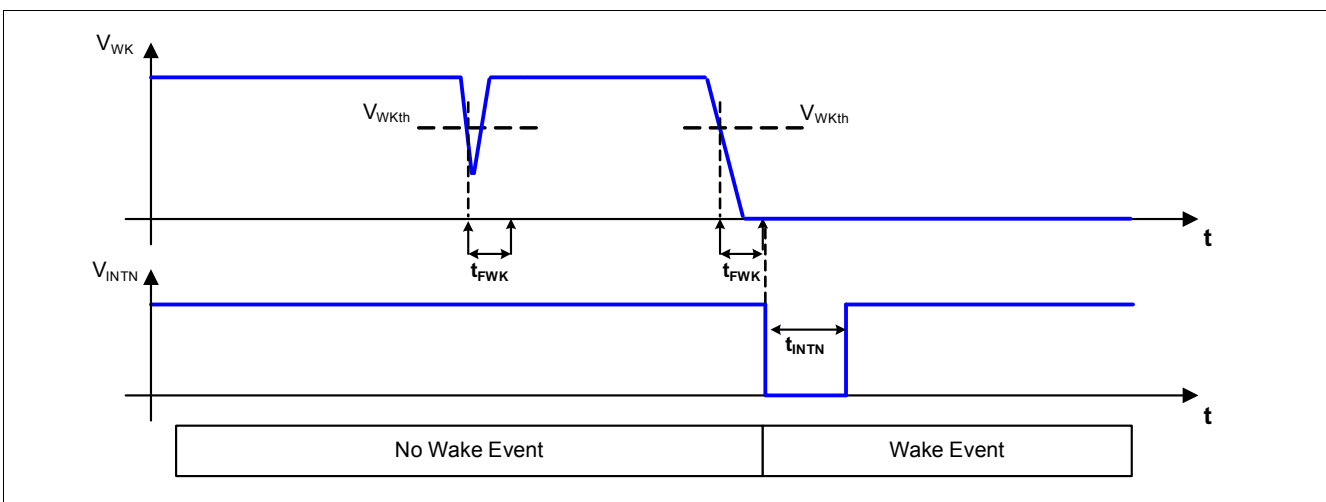

Figure 26 Wake-up Filter Timing for Static Sense

9.2.1 Wake Input Configuration

To ensure a defined and stable voltage level at the internal comparator input, it is possible to configure an integrated current source via the SPI register **WK_PUPD_CTRL**.

Table 17 shows the possible pull-up and pull-down current configuration.

Wake Input

Table 17 Pull-Up / Pull-Down Resistor

WK_PUPD_1	WK_PUPD_0	Output Current	Note
0	0	no current source	WK is floating if left open (default setting)
0	1	pull-down current	WK input internally pulled to GND
1	0	pull-up current	WK input internally pulled to 5V
1	1	automatic switching	If a HIGH level is detected, the pull-up current is activated If low level is detected, the pull down current is activated.

Note: If there is no pull-up or pull-down configured on the WK input, then the respective input should be tied to GND or V_S on board to avoid unintended floating and waking of the pin.

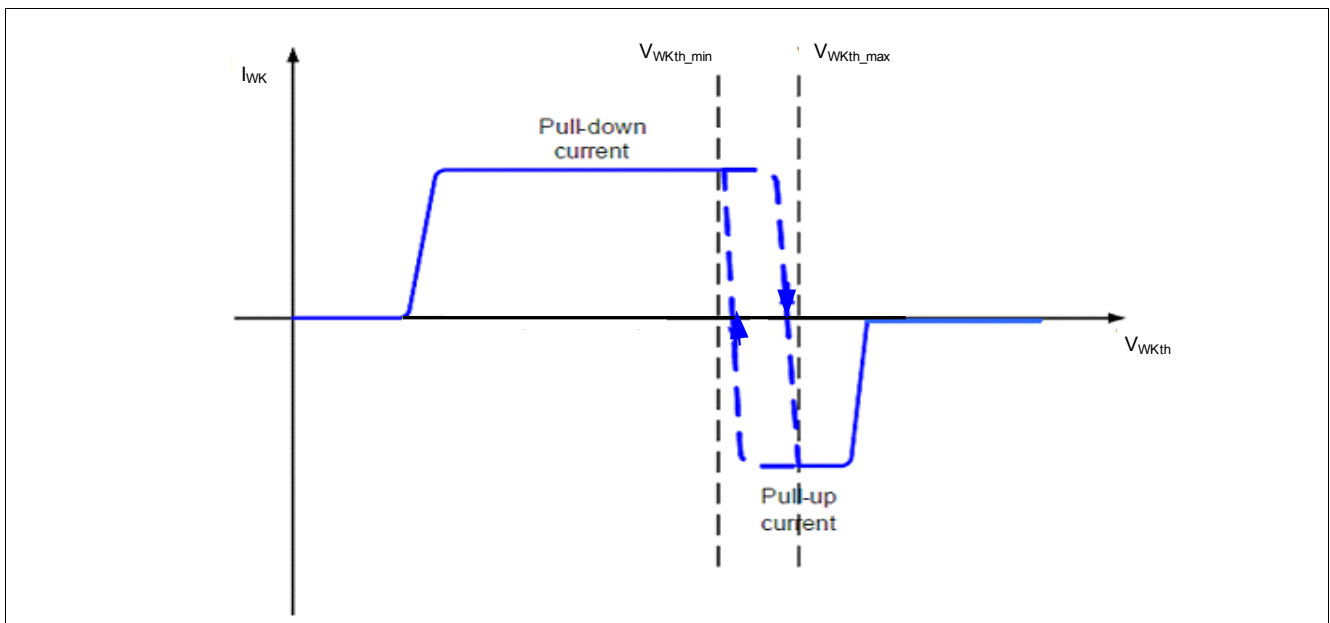

Figure 27 Illustration for Pull-Up / Down Current Sources with Automatic Switching Configuration

Wake Input

9.3 Electrical Characteristics

Table 18 Electrical Characteristics

$T_j = -40^\circ\text{C}$ to $+150^\circ\text{C}$; $T_j = -40^\circ\text{C}$ to $+150^\circ\text{C}$; $V_S = 5.5\text{ V}$ to 28 V ; all voltages with respect to ground, positive current flowing into pin (unless otherwise specified)

Parameter	Symbol	Values			Unit	Note or Test Condition	Number
		Min.	Typ.	Max.			
WK Input Pin characteristics							
Wake-up/monitoring threshold voltage	V_{WKth}	2	3	4	V	Falling and rising edge included	P_9.3.1
Threshold hysteresis	$V_{WKNth,hys}$	0.1	–	0.7	V	²⁾	P_9.3.2
WK pin Pull-up Current	I_{PU_WK}	-20	-10	-3	μA	$V_{WK_IN} = 4\text{ V}$	P_9.3.3
WK pin Pull-down Current	I_{PD_WK}	3	10	20	μA	$V_{WK_IN} = 2\text{ V}$	P_9.3.4
Input leakage current	$I_{LK,I}$	-2	–	2	μA	$0\text{ V} < V_{WK_IN} < V_S + 0.3\text{ V}^{1)}$	P_9.3.5

Timing

Wake-up filter time	t_{FWK}	12	16	20	μs	²⁾	P_9.3.6
---------------------	-----------	----	----	----	---------------	---------------	---------

- 1) With pull-up, pull down current disabled.
- 2) Not subject to production test; specified by design.

Interrupt Function

10 Interrupt Function

10.1 Block and Functional Description

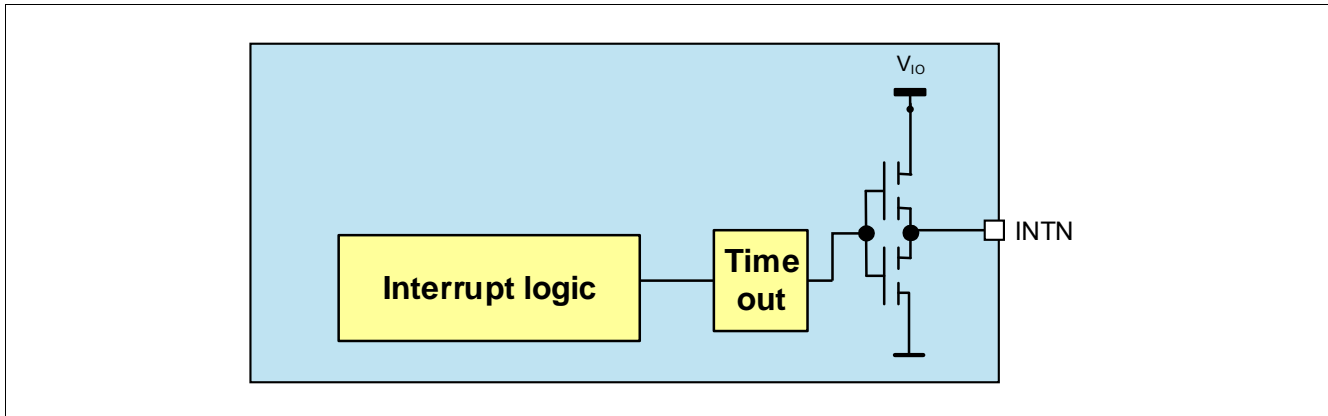

Figure 28 Interrupt Block Diagram

The interrupt is used to signal wake-up events in real time to the microcontroller. The interrupt block is designed as a push/pull output stage as shown in [Figure 28](#). An interrupt is triggered and the INTN pin is pulled low (active low) for t_{INTN} in SBC Normal and Stop Mode and it is released again once t_{INTN} is expired. The minimum HIGH-time of INTN between two consecutive interrupts is t_{INTD} . An interrupt does not automatically cause a SBC mode change.

The following wake-up events will be signaled via INTN:

- All wake-up events stored in the wake status SPI register [WK_STAT_0](#) and [WK_STAT_2](#).
- If the bit CANTO_x is set and if it was not masked out.
- The VBAT (at pin VBSENSE) monitoring threshold is triggered.
- An interrupt is only triggered if the respective function is also enabled as a wake source.
- Automatic transition from PFM to PWM mode in SBC Stop Mode.

The register [WK_LVL_STAT](#) is not generating interrupt events.

In addition to this behavior, an INTN will be triggered when the SBC is sent to SBC Stop Mode and not all bits were cleared in the [WK_STAT_0](#) and [WK_STAT_2](#) registers.

The SPI status registers are updated at every falling edge of the INTN pulse. All interrupt events are stored in the respective register (except the register [WK_LVL_STAT](#)) until the register is read and cleared via an SPI command. The interrupt behavior is shown in [Figure 29](#).

Interrupt Function

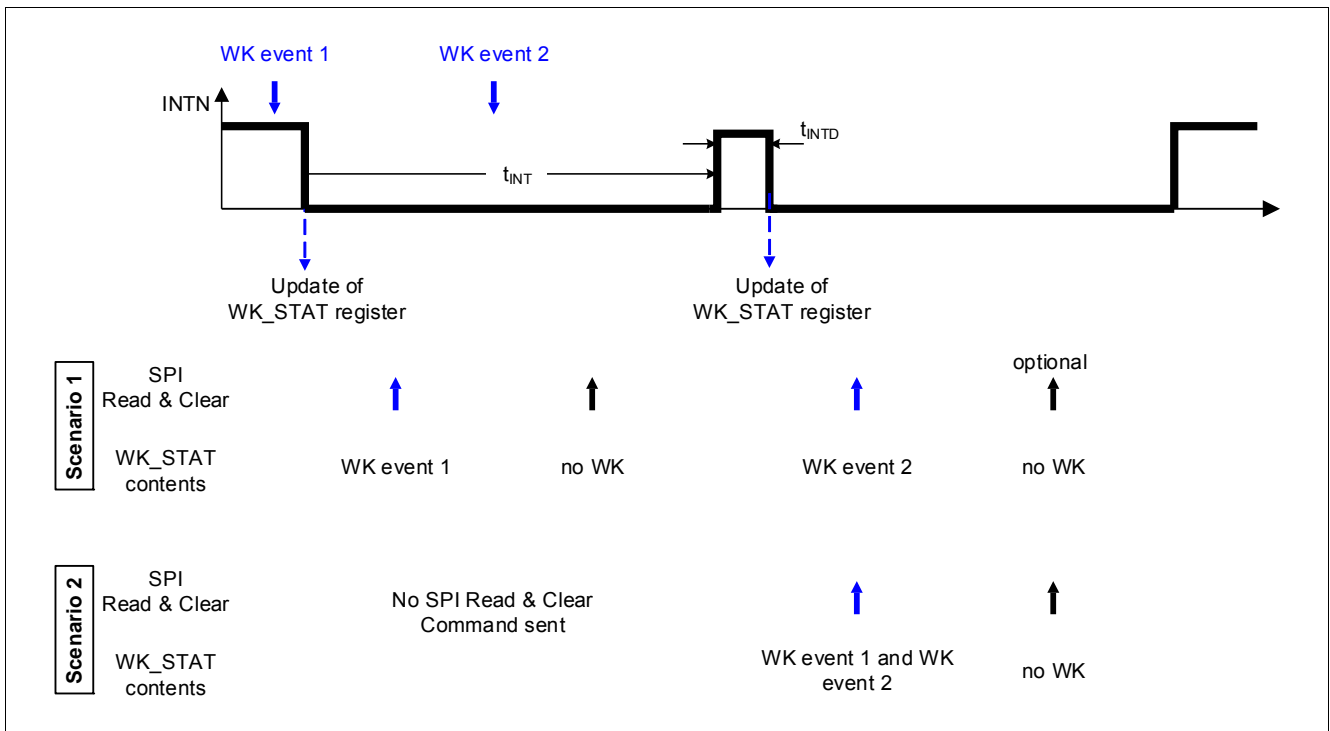

Figure 29 Interrupt Signaling Behavior

Interrupt Function

10.2 Electrical Characteristics

Table 19 Interrupt Output

$V_S = 6\text{ V to }28\text{ V}$; $T_j = -40^\circ\text{C to }+150^\circ\text{C}$; SBC Normal Mode; all voltages with respect to ground; positive current defined flowing into pin (unless otherwise specified)

Parameter	Symbol	Values			Unit	Note or Test Condition	Number
		Min.	Typ.	Max.			
Interrupt output; Pin INTN							
INTN HIGH Output Voltage	$V_{\text{INTN,H}}$	$0.8 \times V_{\text{IO}}$	–	–	V	$I_{\text{INTN}} = -2\text{ mA}$; INTN = OFF	P_10.2.1
INTN LOW Output Voltage	$V_{\text{INTN,L}}$	–	–	$0.2 \times V_{\text{IO}}$	V	$I_{\text{INTN}} = 2\text{ mA}$; INTN = ON	P_10.2.2
INTN Pulse Width	t_{INTN}	80	100	120	μs	¹⁾	P_10.2.3
INTN Pulse Minimum Delay Time	t_{INTD}	80	100	120	μs	¹⁾ Between consecutive pulses	P_10.2.4
Configuration Select; Pin INTN							
Config Pull-down Resistance	R_{CFG}	–	250	–	k Ω	$V_{\text{INTN}} = 5\text{ V}$	P_10.2.5
Config Select Filter Time	$t_{\text{CFG,F}}$	6	8	10	μs	¹⁾	P_10.2.6

1) Not subject to production test; specified by design.

Fail Output

11 Fail Output

11.1 Functional Description

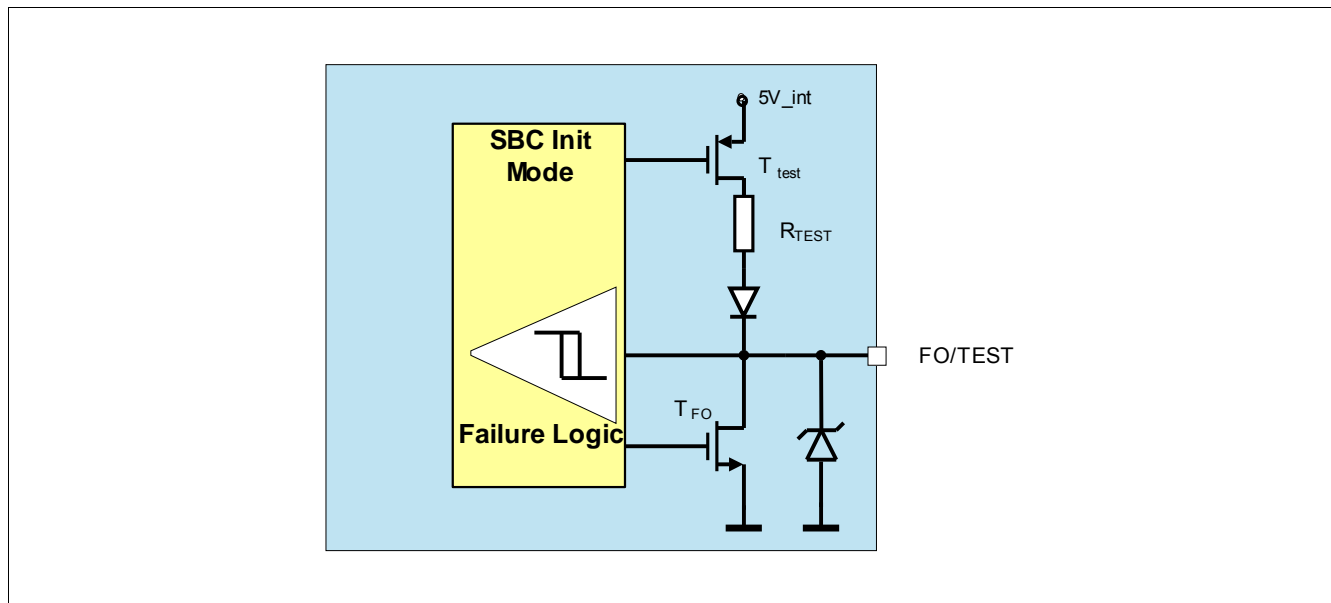

Figure 30 Fail Output Block Diagram

The Fail Output consists of a failure logic block and one LOW-side switch. In case of a failure, the FO output is activated and the SPI bit **FO_ON_STATE**, in the register **DEV_STAT**, is set.

The Failure Output is activated due to the following failure conditions.

Failure Conditions

- After one or two Watchdog Trigger failures depending on the configuration.
- Thermal Shutdown **TSD2**.
- VIO short to GND.
- VIO overvoltage in case that **VIO_OV_RST** bit is set.
- After four consecutive VIO undervoltage detection.

Configurations

Four different configurations can be selected. The selection is done using the pin INTN and the SPI bit **CFG2**.

Table 20 Reasons for Fail

Config	Event	Fail-Safe Mode Entered	SPI CFG2 bit	INTN pin
1	1 × watchdog failure	no	1	External pull-up
2	1 × watchdog failure	yes	1	No ext. pull-up

Fail Output

Table 20 Reasons for Fail (cont'd)

Config	Event	Fail-Safe Mode Entered	SPI CFG2 bit	INTN pin
3	2 × watchdog failure	no	0	External pull-up
4	2 × watchdog failure	yes	0	No ext. pull-up

In order to deactivate the Fail Output, the failure conditions (e.g. TSD2) must not be present anymore and the bit **FO_ON_STATE** needs to be cleared via SPI command.

In case of Watchdog fail, the deactivation of the Fail Output is only allowed after a successful WD trigger, i.e. the **FO_ON_STATE** bit must be cleared.

Note: The Fail Output pin is triggered for any of the above described failure and not only for failures leading to the SBC Fail-Safe Mode.

Fail Output

11.2 Electrical Characteristics

Table 21 Interrupt Output

$V_S = 6\text{ V to }28\text{ V}$; $T_j = -40^\circ\text{C to }+150^\circ\text{C}$; SBC Normal Mode; all voltages with respect to ground; positive current defined flowing into pin (unless otherwise specified)

Parameter	Symbol	Values			Unit	Note or Test Condition	Number
		Min.	Typ.	Max.			
Fail Output; Pin FO/TEST							
FO LOW output voltage (active)	$V_{FO,L}$	–	0.6	1	V	$I_{FO} = 5\text{ mA}$	P_11.2.1
FO HIGH output leakage current (inactive)	$I_{FO,H}$	0	–	2	μA	$V_{FO} = 28\text{ V}$	P_11.2.2
FO/TEST HIGH-input voltage threshold	$V_{TEST,H}$	–	–	3.5	V	–	P_11.2.3
FO/TEST LOW-input voltage threshold	$V_{TEST,L}$	1.5	–	–	V	–	P_11.2.4
FO/Pull-up Resistance at pin TEST	R_{TEST}	2.5	5	10	$\text{k}\Omega$	¹⁾ $V_{TEST} = 0\text{ V}$	P_11.2.6
FO/TEST Input Filter Time	t_{TEST}	52	64	81	μs	¹⁾	P_11.2.7

1) Not subject to production test; specified by design.

12 Supervision Functions

12.1 Reset Function

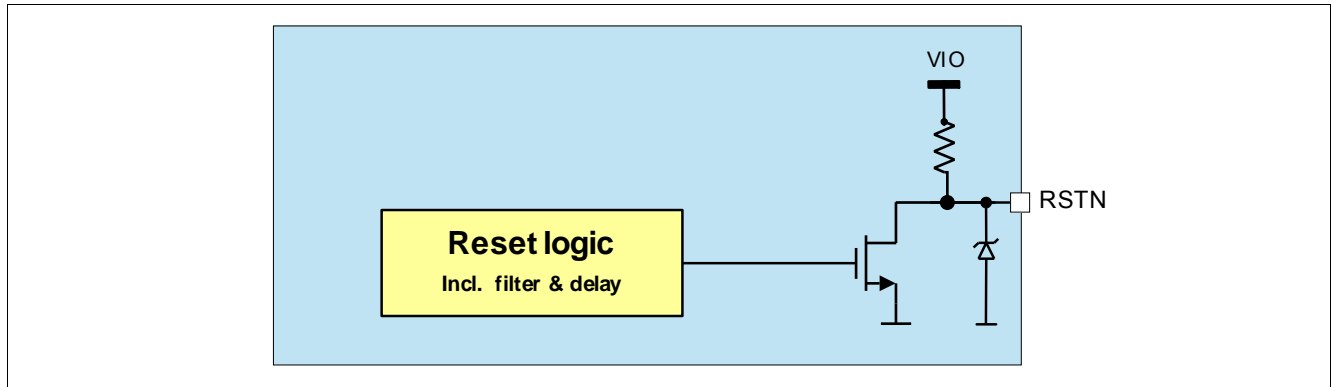

Figure 31 Reset Block Diagram

12.1.1 Reset Output Description

The reset output pin RSTN provides a reset information to the microcontroller, e.g. when the VIO voltage falls below the undervoltage threshold $V_{RT1/2/3/4}$. In case of a reset event due to an undervoltage on VIO, the reset output RSTN is pulled to LOW after the filter time t_{RF} and stays LOW as long as the reset event is present plus a reset delay time t_{RD1} . When connecting the SBC to battery voltage, the reset signal remains LOW initially. When the output voltage V_{IO} has reached the default reset threshold $V_{RT1,f}$ the reset output RSTN is released to HIGH after the reset delay time t_{RD1} . A reset can also occur due to a Watchdog trigger failure. The reset threshold can be adjusted via SPI; the default reset threshold is $V_{RT1,f}$. The RSTN pin has an integrated pull-up resistor. In case reset is triggered, RSTN will pull LOW for $V_S \geq V_{POR,f}$.

The RSTN trigger timing regarding the VIO undervoltage and watchdog trigger is shown in Figure 32.

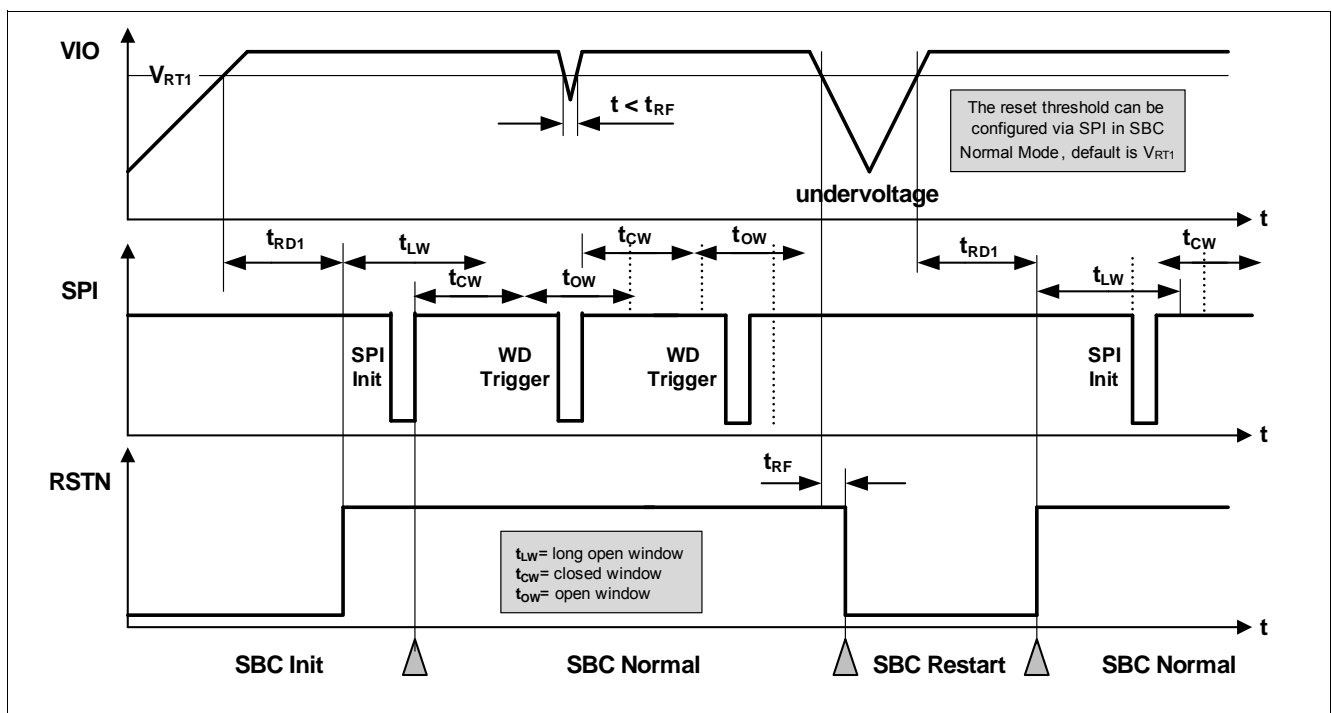

Figure 32 Reset Timing Diagram

Supervision Functions

12.1.2 Soft Reset Description

In SBC Normal and Stop Mode, It is also possible to trigger a Soft Reset via an SPI command in order to bring the SBC into a defined state in case of failures. In this case the microcontroller must send an SPI command and set the **MODE** bits to '11' in the **M_S_CTRL** register. As soon as this command becomes valid, the SBC is set back to SBC Init Mode and all SPI registers are set to their default values (see SPI [Chapter 13.5](#) and [Chapter 13.6](#)).

As soon as the SBC is in SBC Init Mode due to a software reset, it is possible to change the device configuration according to the FO/Test, INTN pins and **CFG2** bit value. For more information, refer to [Chapter 5.1.1](#).

Two different soft reset configurations are possible via the SPI bit **SOFT_RESET_RSTN**:

- The reset output (RSTN) is triggered when the soft reset is executed (default setting, the same reset delay time t_{RD1} applies).
- The reset output (RSTN) is not triggered when the soft reset is executed.

Note: The device must be in SBC Normal Mode or SBC Stop Mode when sending this command. Otherwise, the command will be ignored.

12.2 Watchdog

The watchdog is used to monitor the software execution of the microcontroller and to trigger a reset if the microcontroller stops serving the watchdog due to a lock up in the software.

Two different types of watchdog functions are implemented and can be selected via the bit **WD_WIN** on the **WD_CTRL** register:

- Time-Out Watchdog (default value).
- Window Watchdog.

The respective watchdog function can be selected and programmed in SBC Normal Mode. The configuration remains unchanged in SBC Stop Mode.

Refer to [Table 22](#) to match the SBC Modes with the respective Watchdog Modes.

Table 22 Watchdog Functionality by SBC Modes

SBC Mode	Watchdog Mode	Remarks
INIT Mode	Start with Long Open Window	Watchdog starts with Long Open Window after RSTN is released.
Normal Mode	WD Programmable	Window Watchdog, Time-Out watchdog or switched OFF for SBC Stop Mode.
Stop Mode	Watchdog is fixed or OFF	
Sleep Mode	OFF	SBC will start with Long Open Window when entering Normal Mode.
Restart Mode	OFF	SBC will start with Long Open Window when entering Normal Mode.
Fail-Safe Mode	OFF	SBC will start with Long Open Window when entering Normal Mode.

Watchdog timing is programmed via an SPI command. As soon as the Watchdog is programmed, the timer starts with the new setting and the Watchdog must be served.

The Watchdog is triggered by sending a valid SPI command with write access to **WD_CTRL** register. The trigger SPI command is executed when the Chip Select input (CSN) becomes HIGH.

Supervision Functions

When coming from SBC Init, Restart or in certain cases Stop Mode, the watchdog timer starts with a long open window.

The long open window (t_{LW}) allows the microcontroller to run its initialization sequences and then to trigger the Watchdog via the SPI.

The watchdog timer period can be selected via the watchdog timing bit field (**WD_TIMER** on **WD_CTRL** register) and it is in the range of 10 ms up to 1000 ms. The timer setting is valid for both watchdog types.

The following Watchdog timer periods are available:

- WD Setting 1: 10 ms
- WD Setting 2: 20 ms
- WD Setting 3: 50 ms
- WD Setting 4: 100 ms
- WD Setting 5: 200 ms (reset value)
- WD Setting 6: 500 ms
- WD Setting 7: 1000 ms

In case of a watchdog reset, SBC Restart Mode is started or SBC Fail-Safe Mode is entered according to the configuration and **WD_FAIL** bits are set.

Once the RSTN goes HIGH again, the watchdog immediately starts with a long open window and the SBC enters automatically in SBC Normal Mode.

In SBC Software Development Mode, no reset is generated due to watchdog failure; the watchdog is OFF.

In case of 3 consecutive resets due to WD fail, it is possible in config 1/3 not to generate additional resets by setting the **MAX_3_RST** bit on **WD_CTRL** register.

12.2.1 Time-Out Watchdog

The time-out watchdog is an easier and less secure watchdog than a window watchdog as the watchdog trigger can become active at any time within the configured watchdog timer period.

A correct watchdog service immediately results in starting a new watchdog timer period. Taking the tolerances of the internal oscillator into account leads to the safe trigger area defined in **Figure 33**.

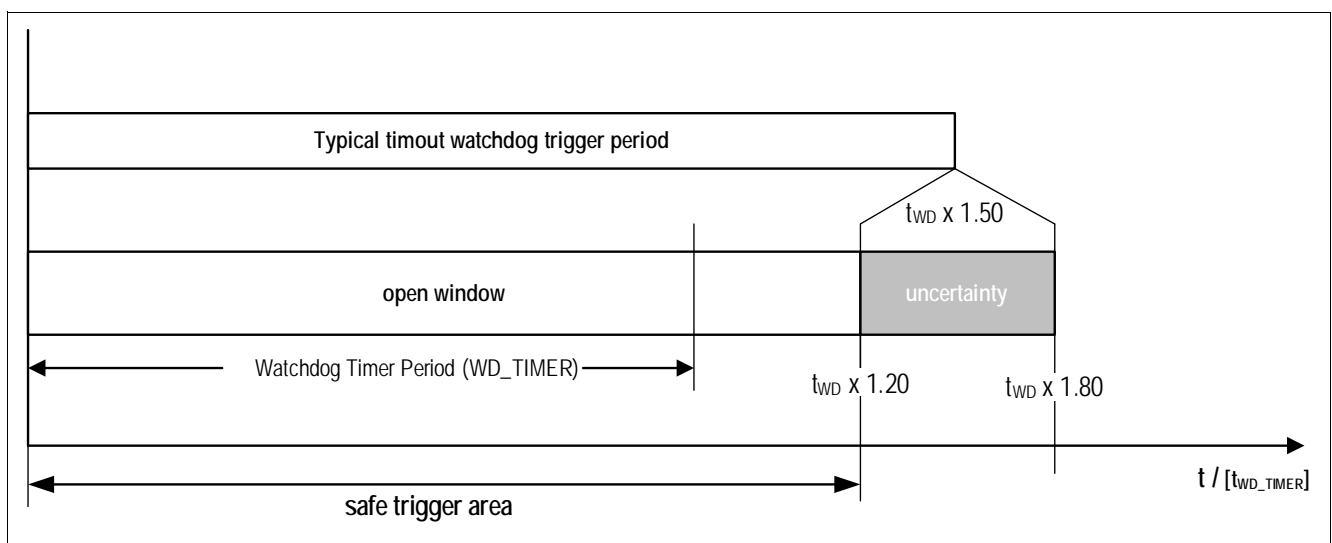

Figure 33 Time-Out Watchdog Definitions

Supervision Functions

If the time-out watchdog period elapses, a watchdog reset is created by setting the reset output RSTN LOW and the SBC switches to SBC Restart or SBC Fails-Safe Mode.

12.2.2 Window Watchdog

Compared to the time-out watchdog, the characteristic of the window watchdog is that the watchdog timer period is divided between a closed and an open window. The watchdog must be triggered inside the open window.

A correct watchdog trigger results in starting the window watchdog period by a closed window followed by an open window.

The watchdog timer period is at the same time the typical trigger time and defines the middle of the open window.

Taking the oscillator tolerances into account leads to a safe trigger area of:

$$t_{WD} \times 0.72 < \text{safe trigger area} < t_{WD} \times 1.20.$$

The typical closed window is defined to a width of 60% of the selected window watchdog timer period. Taking the tolerances of the internal oscillator into account leads to the timings as defined in **Figure 34**.

A correct Watchdog service immediately results in starting the next closed window.

Should the trigger signal meet the closed window or should the watchdog timer period elapse, a watchdog reset is created by setting the reset output RSTN LOW and the SBC switches to SBC Restart or Fail-Safe Mode.

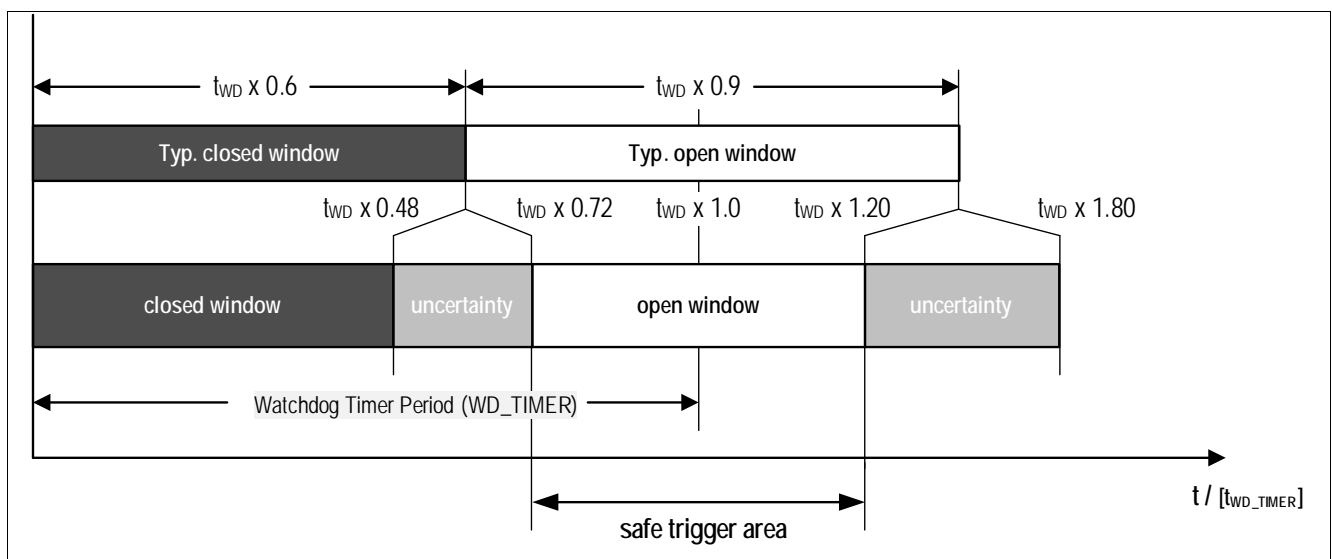

Figure 34 Window Watchdog Definitions

12.2.3 Checksum

A checksum bit is part of the SPI command to trigger the watchdog and to set the watchdog setting. The sum of the 8 bits in the register **WD_CTRL** needs to be even. This is realized by either setting the bit **CHECKSUM** to “0” or “1”. If the checksum is wrong, the SPI command is ignored (watchdog not triggered, settings not changed) and the bit **SPI_FAIL** is set.

The checksum is calculated by taking all 8 data bits into account.

(12.1)

$$\text{CHKSUM} = \text{Bit15} \oplus \dots \oplus \text{Bit8}$$

Supervision Functions

12.2.4 Watchdog during Stop Mode

The watchdog can be disabled via SPI in Stop Mode.

For safety reasons, there is a special sequence to be ensured in order to disable the watchdog as described in **Figure 35**. Two dedicated SPI bits (**WD_STM_EN_0** and **WD_STM_EN_1**) in the registers **WD_CTRL** and **WK_CTRL_0**.

If this sequence is not fulfilled, then the bit **WD_STM_EN_1** will be cleared and the sequence has to be started again. As soon as the SBC is set to SBC Normal Mode, then the bits **WD_STM_EN_1** and **WD_STM_EN_0** are cleared and this sequence must be followed again to switch OFF the watchdog.

The watchdog can be enabled by triggering the watchdog in SBC Stop Mode or by switching back to SBC Normal Mode via SPI. In both cases, the watchdog will start with a long open window and the bits **WD_STM_EN_1** and **WD_STM_EN_0** are cleared. After the long open window, the watchdog has to be served as configured in the **WD_CTRL** register.

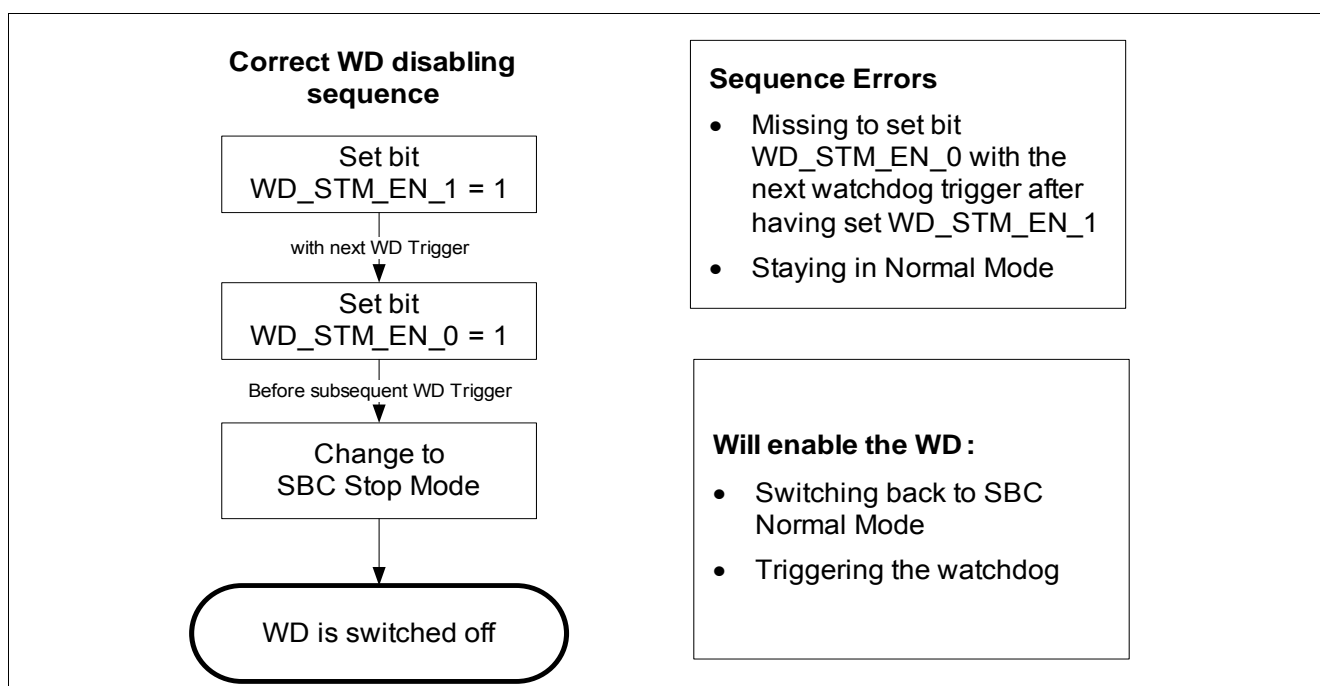

Figure 35 Watchdog Disabling Sequence

*Note: The bit **WD_STM_EN_0** will be cleared automatically when the sequence is started and it was “1” before.*

12.2.4.1 Watchdog Start in SBC Stop Mode due to BUS Wake

In SBC Stop Mode the watchdog can be disabled. In addition a feature can be enabled to start the watchdog with any BUS wake during Stop Mode. The feature is enabled by setting the bit **WD_EN_WK_BUS**. The bit can only be changed in SBC Normal Mode and needs to be programmed before entering SBC Stop Mode: it is not reset by the SBC. The sequence described in **Chapter 12.2.4** needs to be followed to disable the WD.

With the function enabled, the watchdog will start again with any wake on CANx. The wake on CANx will generate an interrupt and the RXDCANx is pulled to low. The watchdog starts a with long open window. The watchdog can be triggered in SBC Stop Mode or the SBC can be switched to SBC Normal Mode. To disable the watchdog again, the SBC needs to be switched to Normal Mode and the sequence needs to be sent again.

The sequence is shown in **Figure 36**.

Supervision Functions

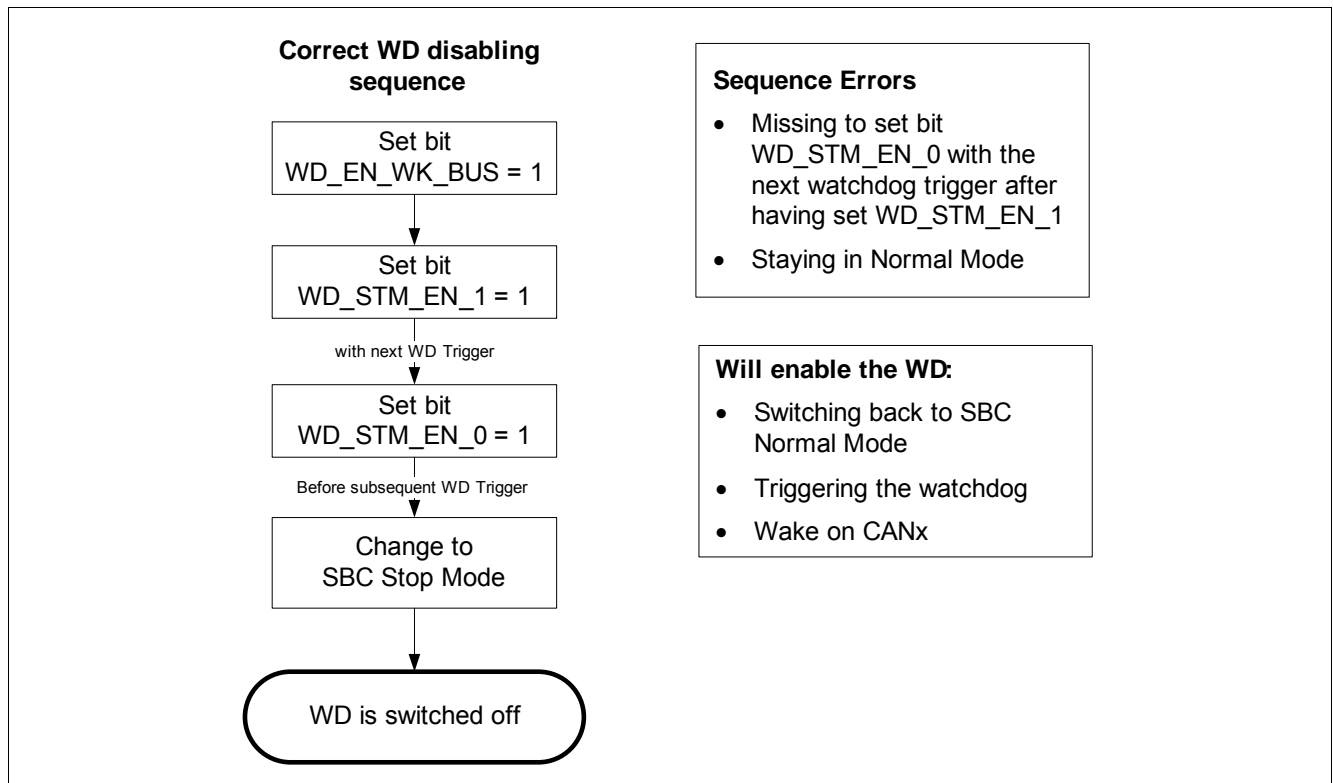

Figure 36 Watchdog Disabling Sequence (with wake via BUS)

12.3 V_S Power ON Reset

When powering up, the device detects the V_S Power ON Reset when $V_S > V_{POR,f}$ and the **POR** is set to indicate that all SPI registers are set to POR default setting. The Buck regulator starts up. The RSTN output is kept LOW and is only released when VIO has exceeded $V_{RT1,r}$ and after t_{RD1} has elapsed.

If $V_S < V_{POR,f}$ an internal reset is generated and the SBC is switched OFF. The SBC will restart in SBC INIT Mode when $V_S > V_{POR,r}$ rising. Timing behavior is shown in **Figure 37**.

Supervision Functions

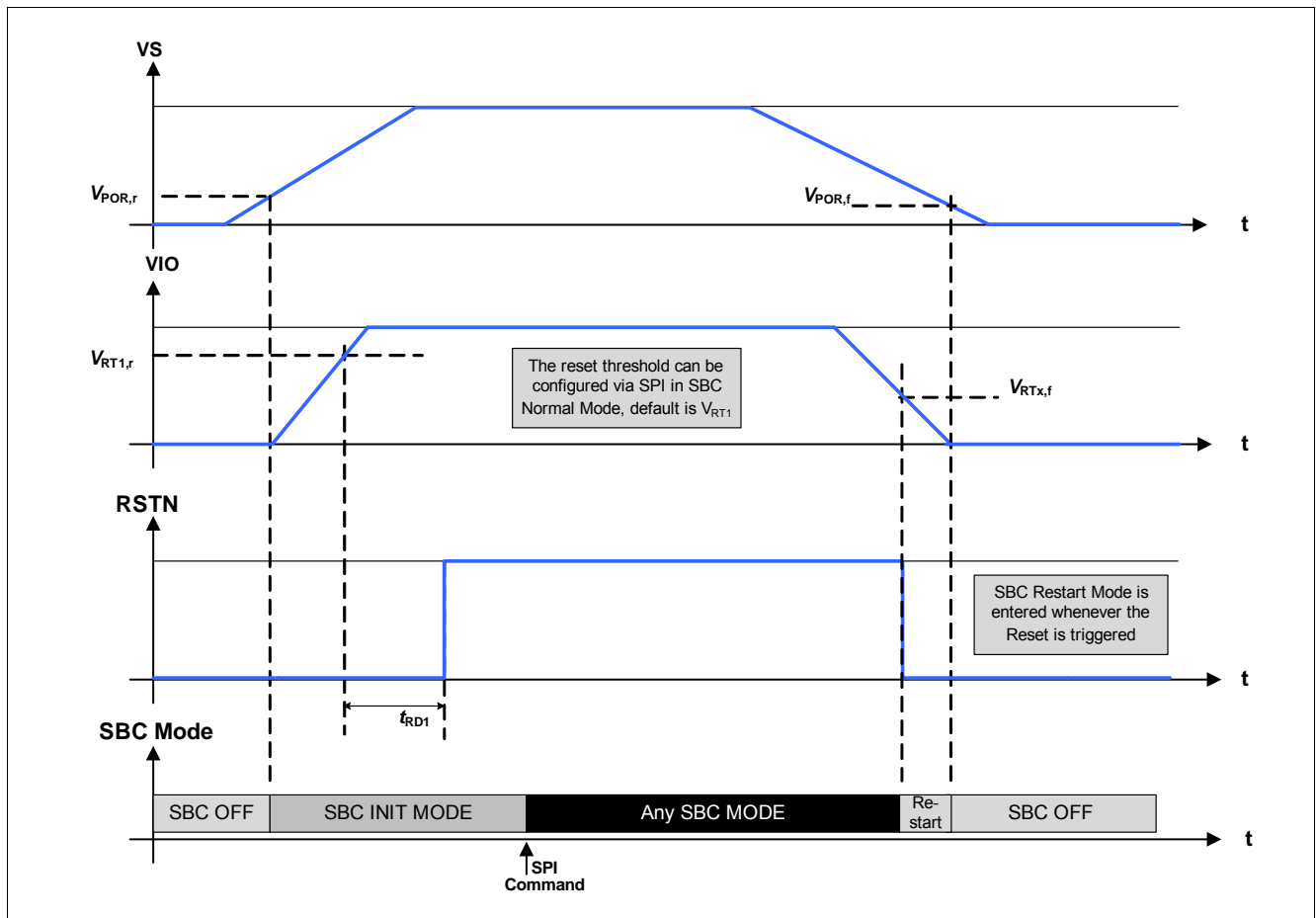

Figure 37 Ramp up / down example of Supply Voltage

12.4 Measurement Interface

The measurement interface is sensing the voltage on WK and VBSENSE pin, converting to digital using a 8 bit SAR high input voltage analog to digital converter and store the value in **ADC_STAT**.

The input selection (between WK pin or VBSENSE pin) is made by **ADC_SEL** bit on **HW_CTRL_1** register.

The feature is available only in SBC Normal Mode. In SBC Stop, Sleep and Fail Safe Mode, the feature is automatically disabled to reduce current consumption. **Figure 38** shows the block diagram.

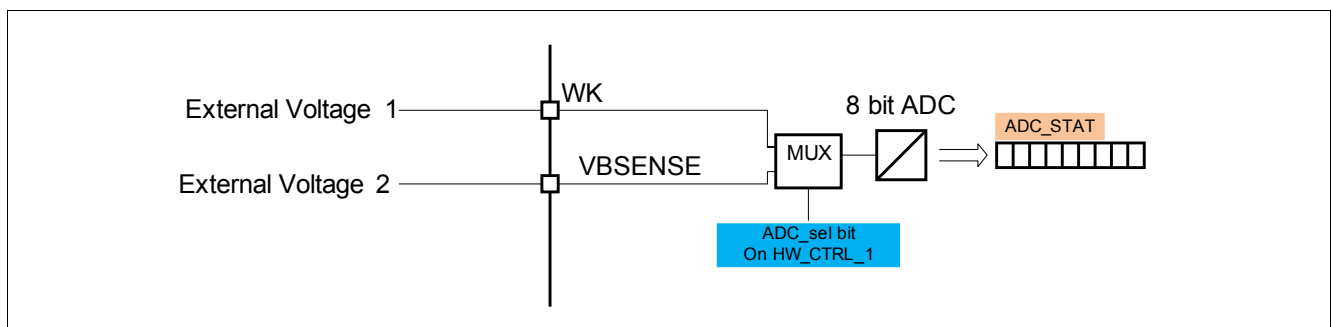

Figure 38 Measure Interface: basic concept implementation.

Supervision Functions

12.5 Fast Battery Voltage Monitoring

A battery monitoring feature is implemented in the TLE9278BQX V33 in order to provide a fast signalization path to the microcontroller in case of low battery voltage condition.

The block diagram is shown in **Figure 39**. The functionality is as follows:

- The battery voltage is monitored on the dedicated pin VBSense (see also the application diagram in **Chapter 14.1**).
- If the voltage falls below the selected threshold, an interrupt is triggered at the INTN pin and the bit **VBAT_UV_LATCH** in the register **WK_STAT_2** is set.
- The bit can be cleared via an SPI if the voltage is above the thresholds again.
- The bit **VBAT_UV_STATE** in the register **WK_LVL_STAT** is showing the actual level of the comparator output, i.e. if the battery voltage is below or above the selected monitoring threshold.
- The monitoring threshold can be selected via SPI bit with **VBSense_CFG** in the **WK_CTRL_0** register. The feature can be enable in SBC Normal, Stop and Restart Mode using **VBSense_EN** bit on the **WK_CTRL_0** register. Four thresholds are available: $V_{BSense0,f} \dots V_{BSense3,f}$.
- The Fast Battery voltage monitoring feature is filtered with the time $t_{F_VBSense}$.

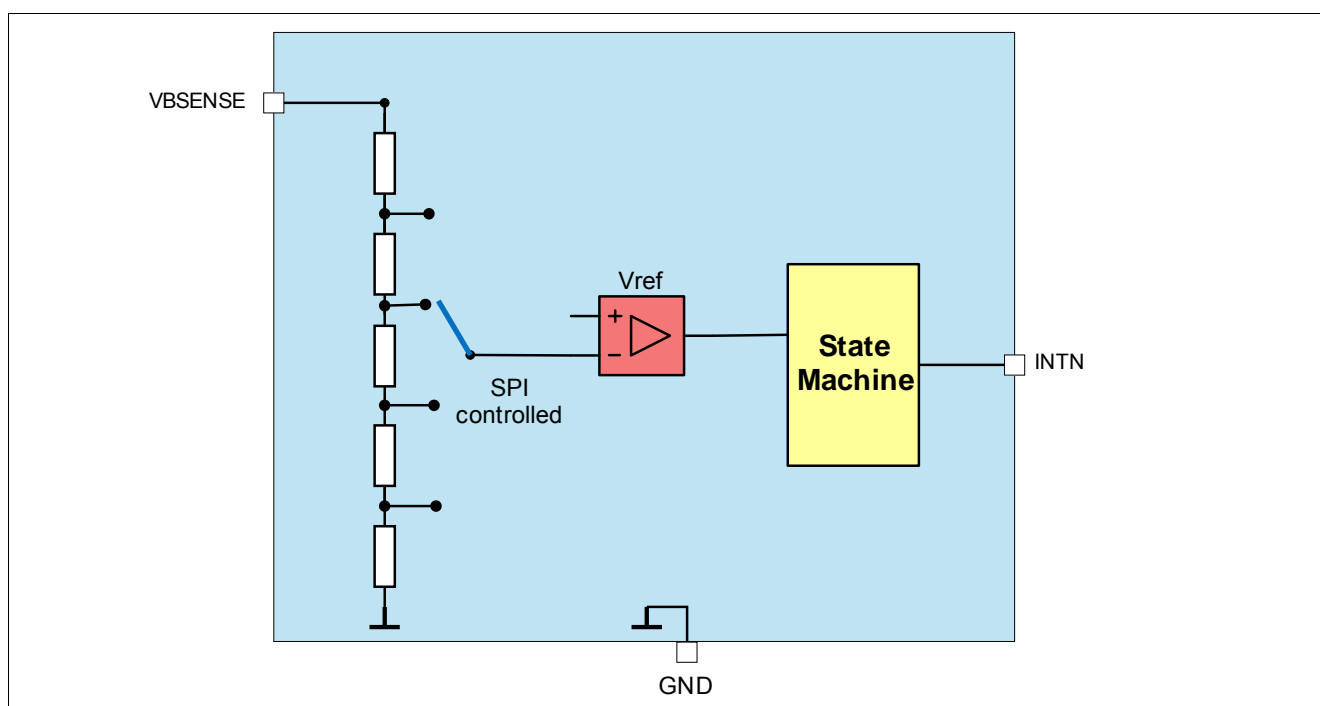

Figure 39 Fast Battery Voltage Monitoring Block Diagram

12.6 VBSense Boost deactivation

In case of low battery voltage conditions, where the Boost module can operate out of nominal functional range, it is possible to disable the boost and supply the VS pin only with the output boost capacitor.

The **BST_VB_UV_OFF** bit enable this feature.

As soon as the battery voltage is crossing the **Boost_{OFF,th}** threshold, the boost is disabled and **VB_UV_BST** is set.

The Boost is automatically enabled when the VBSense is crossing **Boost_{ON,th}** threshold.

The **VB_UV_BST** bit has to be cleared manually.

Supervision Functions

12.7 VIO Undervoltage and Undervoltage Prewarning

A first-level voltage detection threshold is implemented as a prewarning for microcontroller. The prewarning event is signaled with the bit **VIO_WARN**. No other actions are taken.

As described in [Chapter 12.1](#) and shown in [Figure 40](#), when the VIO voltage reaches the undervoltage threshold (V_{RTx}), a reset will be triggered (RSTN pulled 'LOW'), the bit **VIO_UV** is set and the SBC will enter SBC Restart Mode.

Note: The **VIO_WARN** and **VIO_UV** bits are not set in SBC Sleep Mode as $VIO = 0\text{ V}$ in this case.

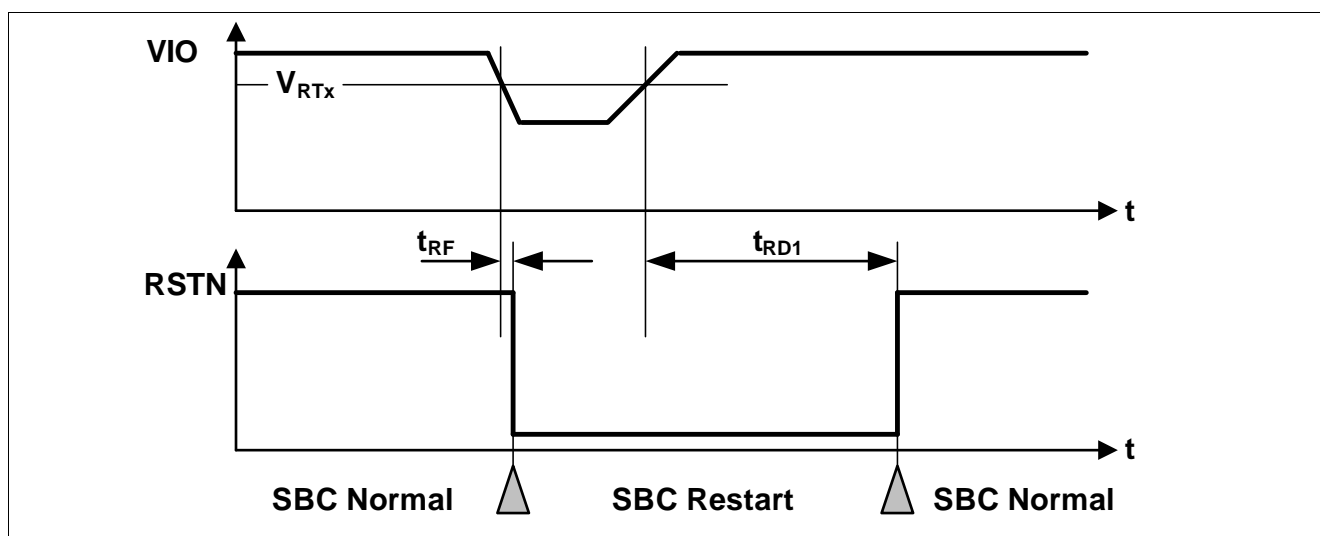

Figure 40 VIO Undervoltage Timing Diagram

An additional safety mechanism is implemented to avoid repetitive VIO undervoltage resets:

- A counter is increased for every consecutive VIO undervoltage event.
- The counter is active in SBC Init, Normal and Stop Mode and as $V_S > V_{s,uv}$.
- A 4th consecutive VIO undervoltage events will lead to SBC Fail-Safe Mode entry and to setting the bit **VIO_UV_FS**.
- The counter is cleared when:
 - SBC Fail-Safe Mode is entered.
 - The bit **VIO_UV** is cleared.
 - A Soft Reset is triggered.

Note: It is recommended to clear the **VIO_UV** bit once it was set and detected.

12.8 VIO Overvoltage

For fail safe reasons, a configurable VIO overvoltage detection feature is implemented.

In case the $V_{IO,ov,r}$ threshold is crossed, the SBC triggers following measures depending on the configuration:

- The bit **VIO_OV** is always set.
- If the bit **VIO_OV_RST** is set in config 1/3, then SBC Restart Mode is entered. The FO output is activated. After the reset delay time (t_{RD1}), the SBC Restart Mode is exited and SBC Normal Mode is resumed even if the VIO overvoltage event is still present (see also [Figure 41](#)). The **VIO_OV_RST** bit is cleared automatically.
- If the bit **VIO_OV_RST** is set in config 2/4, then SBC Fail-Safe Mode is entered and FO output is activated.

Supervision Functions

If the **VIO_OV_RST** bit is not set, one overvoltage event on VIO pin will set the **VIO_OV** bit but no reset is generated and FO remains OFF. The SBC doesn't change the SBC mode.

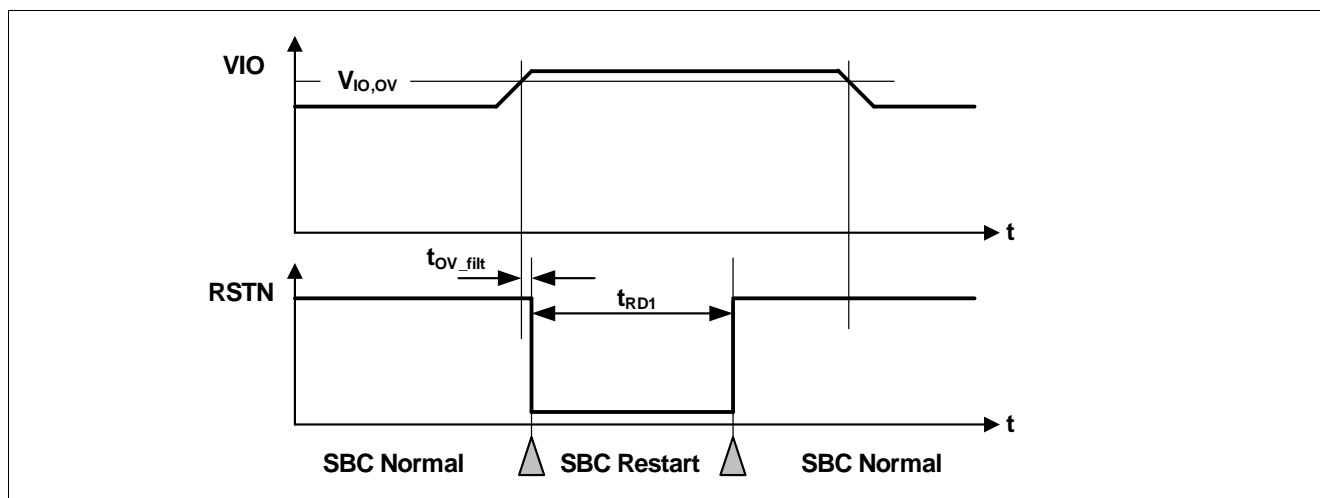

Figure 41 VIO Overvoltage Timing Diagram

12.9 VIO Short Circuit

The following protection feature is implemented for VIO:

- When VIO stays below the undervoltage threshold V_{RTx} for more than $t_{VIO,SC}$, the SBC enters SBC Fail-Safe Mode and turns off VCC1. This feature is available only if $V_s > V_{S,UV}$. In addition the SPI status bit **VIO_SC** is set. The SBC can exit SBC Fail Safe Mode via a wake-up event on CANx and/or WK pin.

12.10 VEXT Undervoltage

Following protection feature is implemented for VEXT:

- If VEXT drops below the $V_{EXT,UV}$ threshold, the SPI bit **VREG_UV** is set and can only be cleared via SPI.

*Note: The **VREG_UV** flag is not set during turn-on or turn-off of VEXT.*

12.11 Thermal Protection

The thermal protection mechanism is designed in such a way that the individual modules (VCC1, CANx, Boost and VEXT) can remain active as long as possible in case of high temperature. The following thermal protection features are available and signaled via SPI:

- Thermal Prewarning T_{JPW}
- Overtemperature Protection:
 - Overtemperature shut down with 2 levels of priority (**TSD1** for peripherals and **TSD2** for microcontroller supply).
 - The **TSD1** status bit is a combination of CANx, Boost and VEXT thermal shutdown.
 - The **TSD2** status bit is related to VCC1.
 - If the VEXT base driver sensor detected that T_{JTSD1} has been reached, it is switched OFF as an initial protection measure. The control bits (**VEXT_ON** bits on **M_S_CTRL** register) are reset and the bits **VEXT_OT** and **TSD1** are set. The other output stages are not affected if their T_{JTSD1} threshold is not reached. When the overtemperature event is not present anymore, the VEXT must be switched ON by setting the **VEXT_ON** bit.

Supervision Functions

- If one of the CANx output stages reaches the T_{jTSD1} temperature threshold, then the transmitter is switched OFF individually as first-level protection measure. The respective control bits are not reset and the **TSD1** and CAN_x_FAIL bits are set. The CANx drivers are automatically switched on again when the overtemperature condition is no longer present. The user has to reset the **BUS_STAT_0** and **BUS_STAT_2** registers via SPI.
- If VCC1 reaches the T_{jTSD2} temperature threshold, the SBC is sent to SBC Fail-Safe Mode. The SBC stays in SBC Fail-Safe Mode for at least t_{TSD2} (typ.1s) after the **TSD2** event is not present anymore. The **VCC1_OT** is set. The default wake sources CANx and WK are enabled together with the Fail Safe output.
- Boost Switched OFF in case of **TSD1** along with the **BOOST_OT** bit. The Boost has to activate again setting the **BOOST_EN** after the thermal shutdown event.
- Once the respective bits (**TSD1**, **TSD2**) are set, they can be cleared via SPI if the condition is not present anymore.

12.11.1 Temperature Prewarning

As a next level of thermal protection a temperature prewarning is implemented if the main supply VCC1 reaches the thermal prewarning temperature threshold T_{jPW} . Then the status bit **TPW** is set. This bit can only be cleared via SPI once the overtemperature is not present anymore. The thermal prewarning is only active if the VCC1 is in PWM mode.

Supervision Functions

12.12 Electrical Characteristics

Table 23 Electrical Specification

$V_S = 5.5\text{ V to }28\text{ V}$; $T_j = -40^\circ\text{C to }+150^\circ\text{C}$; SBC Normal Mode; all voltages with respect to ground; positive current defined flowing into pin (unless otherwise specified)

Parameter	Symbol	Values			Unit	Note or Test Condition	Number
		Min.	Typ.	Max.			
VIO Monitoring, Reset Generator with VIO = VCC1 = 3.3 V; Pin RSTN							
Undervoltage Prewarning Threshold Voltage	$V_{PW,f}$	3.0	3.1	3.2	V	VIO falling, VIO_WARN bit is set	P_12.10.57
Undervoltage Prewarning Threshold Voltage	$V_{PW,r}$	3.10	3.2	3.27	V	VIO rising	P_12.10.58
Reset Threshold Voltage RT1,f	$V_{RT1,f}$	2.95	3.05	3.15	V	Default setting; VIO falling	P_12.10.34
Reset Threshold Voltage RT1,r	$V_{RT1,r}$	3.0	3.1	3.2	V	Default setting; VIO rising	P_12.10.35
Reset Threshold Voltage RT2,f	$V_{RT2,f}$	2.5	2.6	2.7	V	SPI option; VIO falling	P_12.10.36
Reset Threshold Voltage RT2,r	$V_{RT2,r}$	2.55	2.65	2.75	V	SPI option; VIO rising	P_12.10.37
Reset Threshold Voltage RT3,f	$V_{RT3,f}$	2.2	2.3	2.4	V	SPI option; $V_S \geq 4\text{ V}$; VIO falling	P_12.10.38
Reset Threshold Voltage RT3,r	$V_{RT3,r}$	2.25	2.35	2.45	V	SPI option; $V_S \geq 4\text{ V}$; VIO rising	P_12.10.39
Reset Threshold Voltage RT4,f	V_{RT34f}	2.0	2.1	2.2	V	SPI option; $V_S \geq 4\text{ V}$; VIO falling	P_12.10.55
Reset Threshold Voltage RT4,r	$V_{RT4,r}$	2.05	2.15	2.25	V	SPI option; $V_S \geq 4\text{ V}$; VIO rising	P_12.10.56
VIO Monitoring, Overvoltage detection							
VIO Overvoltage Detection Threshold	$V_{IO,OV,r}$	3.5	3.63	3.75	V	¹⁾ Rising VIO PCFG = GND	P_12.10.41
VIO Overvoltage Detection Threshold	$V_{IO,OV,f}$	3.45	3.56	3.7	V	¹⁾ Falling VIO PCFG = GND	P_12.10.45
VIO Overvoltage filter time	$t_{VIO,OV}$	12	15	21	μs	¹⁾	P_12.10.60

Supervision Functions

Table 23 Electrical Specification (cont'd)

$V_S = 5.5 \text{ V to } 28 \text{ V}$; $T_j = -40^\circ\text{C to } +150^\circ\text{C}$; SBC Normal Mode; all voltages with respect to ground; positive current defined flowing into pin (unless otherwise specified)

Parameter	Symbol	Values			Unit	Note or Test Condition	Number
		Min.	Typ.	Max.			
VIO Monitoring, Reference Supply Undervoltage detection							
VS Undervoltage Detection Threshold	$V_{S,UV}$	3.7	4	4.4	V	Supply UV supervision for VIO PCFG = open; includes rising and falling threshold	P_12.10.43
VIO Short to GND Filter Time	$t_{VIO,SC}$	3.2	4	4.8	ms	¹⁾	P_12.10.10
Electrical Characteristics RSTN							
Reset LOW Output Voltage	$V_{RSTN,LOW}$	–	0.2	0.4	V	$I_{RSTN} = 1 \text{ mA}$ for $V_{IO} \geq 1 \text{ V}$	P_12.10.12
Reset HIGH Output Voltage	$V_{RSTN,HIGH}$	$0.7 \times V_{IO}$	–	$V_{IO} + 0.3 \text{ V}$	V	$I_{RSTN} = -20 \mu\text{A}$	P_12.10.13
Reset Pull-up Resistor	R_{RSTN}	10	20	40	k Ω	$V_{RSTN} = 0 \text{ V}$	P_12.10.14
Reset Filter Time	t_{RF}	4	10	26	μs	¹⁾ $V_{IO} < V_{RT1x}$ to RSTN = L	P_12.10.15
Reset Delay Time	t_{RD1}	1.5	2	2.5	ms	¹⁾²⁾	P_12.10.16
VEXT Monitoring							
V_{EXT} Undervoltage Detection	$V_{EXT,UV}$	4.5	4.6	4.75	V	5 V option VEXT_VCFG=00_B falling	P_12.10.17
V_{EXT} Undervoltage Detection	$V_{EXT,UV}$	2.65	2.85	3.00	V	3.3 V option VEXT_VCFG=01_B falling	P_12.10.46
V_{EXT} Undervoltage Detection	$V_{EXT,UV}$	1.45	1.52	1.6	V	1.8 V option VEXT_VCFG=10_B falling	P_12.10.61
V_{EXT} Undervoltage Detection	$V_{EXT,UV}$	0.94	1.03	1.1	V	1.2 V option VEXT_VCFG=11_B falling	P_12.10.62
V_{EXT} Undervoltage detection hysteresis	$V_{EXT,UV, hys}$	20	100	250	mV	¹⁾	P_12.10.63
Watchdog Generator							
Long Open Window	t_{LW}	160	200	240	ms	¹⁾	P_12.10.18
Internal Oscillator	f_{CLKSBC}	0.8	1.0	1.2	MHz		P_12.10.19
Minimum Waiting Time during SBC Fail-Safe Mode							
Min. waiting time in Fail-Safe	$t_{FS,min}$	80	100	120	ms	¹⁾³⁾	P_12.10.20
Power-ON Reset, Over-/Undervoltage Protection							
V_S Power ON reset rising	$V_{POR,r}$	4.5	–	5	V	V_S increasing	P_12.10.21

Supervision Functions

Table 23 Electrical Specification (cont'd)

$V_S = 5.5\text{ V to }28\text{ V}$; $T_j = -40^\circ\text{C to }+150^\circ\text{C}$; SBC Normal Mode; all voltages with respect to ground; positive current defined flowing into pin (unless otherwise specified)

Parameter	Symbol	Values			Unit	Note or Test Condition	Number
		Min.	Typ.	Max.			
V_S Power ON reset falling	$V_{POR,f}$	–	–	3	V	V_S decreasing	P_12.10.22

Battery Voltage Monitoring

VBSense Monitoring Threshold 0	$V_{BSENSE0,f}$	7.5	8.0	8.5	V	VBSense decreasing	P_12.10.24
VBSense Monitoring Threshold 1	$V_{BSENSE1,f}$	5.7	6.0	6.3	V	VBSense decreasing	P_12.10.25
VBSense Monitoring Threshold 2	$V_{BSENSE2,f}$	4.2	4.5	4.8	V	VBSense decreasing	P_12.10.26
VBSense Monitoring Threshold 3	$V_{BSENSE3,f}$	3.2	3.5	3.8	V	VBSense decreasing	P_12.10.27
VBSense Monitoring Threshold Hysteresis	$V_{BSENSE,hys}$	50	100	200	mV	¹⁾	P_12.10.28
VBSense Monitoring Filter Time	$t_{F_VBSense}$	13	16	21	μs	¹⁾	P_12.10.48
VBSense Boost deactivation threshold	$Boost_{OFF,th}$	1.5	1.75	2	V	VBSense falling	P_12.10.49
VBSense Boost activation threshold	$Boost_{ON,th}$	2.5	2.75	3	V	VBSense rising	P_12.10.80

Overtemperature Shutdown

Thermal Prewarning ON Temperature	T_{jPW}	125	145	165	$^\circ\text{C}$	¹⁾	P_12.10.29
Thermal Shutdown TSD1	T_{jTSD1}	165	185	200	$^\circ\text{C}$	¹⁾	P_12.10.30
Thermal Shutdown TSD2	T_{jTSD2}	165	185	200	$^\circ\text{C}$	¹⁾	P_12.10.31
Thermal Shutdown Hysteresis	T_{HYS}	–	20	–	$^\circ\text{C}$	¹⁾	P_12.10.81
Deactivation time after thermal shutdown TSD2	t_{TSD2}	0.8	1	1.2	s	¹⁾	P_12.10.32

Measurement Interface

Resolution	–		8		Bits	Input voltage full scale = 0V ..39 V	P_12.10.70
Guarantee offset error	–	-1	–	+1	LSB	Input voltage full scale = 0V ..39 V	P_12.10.71
Gain error	–	-1.5	–	1.5	%FSR	Full scale range	P_12.10.72
Differential non-linearity (DNL)	–	-1.5	–	1.5	LSB	Input voltage full scale = 0V..39 V	P_12.10.73
Integral non-linearity (INL)	–	-1.5	–	1.5	LSB	Input voltage full scale = 0 V..39 V	P_12.10.74

¹⁾ Not subject to production test; specified by design.

Supervision Functions

- 2) The reset delay time will start when VIO crosses above the selected VRTx threshold.
- 3) This time applies for all failure entries except a device thermal shutdown (TSD2 has a 1 s waiting time t_{TSD2}).

13 Serial Peripheral Interface

13.1 SPI Protocol Description

The 16-bit wide Control Input Word is read via the data input SDI, which is synchronized with the clock input CLK provided by the microcontroller. The output word appears synchronously at the data output SDO (see [Figure 42](#)). The transmission cycle begins when the chip is selected by the input CSN (Chip Select Not), LOW active. After the CSN input returns from LOW to HIGH, the word that has been read is interpreted according to the content. The SDO output switches to tristate status (HIGH impedance) at this point, thereby releasing the SDO bus for other use. The state of SDI is shifted into the input register with every falling edge on CLK. The state of SDO is shifted out of the output register after every rising edge on CLK. The SPI of the SBC is not daisy-chain capable.

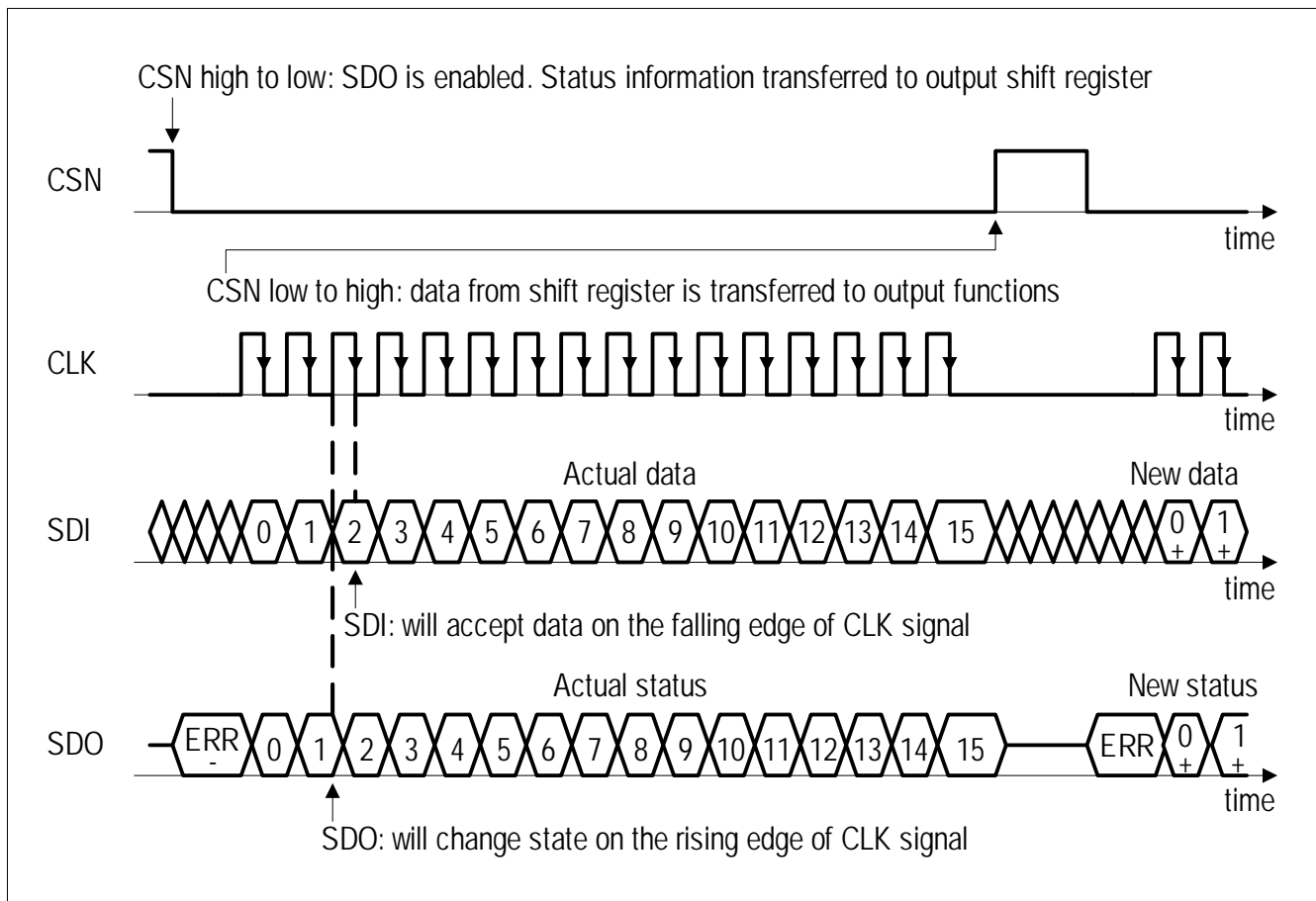

Figure 42 SPI Data Transfer Timing (note the reversed order of LSB and MSB shown in this figure compared to the register description)

13.2 Failure Signalization in the SPI Data Output

When the microcontroller sends a wrong SPI command to the SBC, the SBC ignores the information. Wrong SPI commands are either invalid SBC mode commands or commands which are prohibited by the state machine to avoid undesired device or system states (see below). In this case the diagnosis bit '**SPI_FAIL**' is set and the SPI Write command is ignored (mostly no partial interpretation). This bit can only be reset by actively clearing it via a SPI command.

Invalid SPI Commands leading to **SPI_FAIL are listed below:**

- Illegal state transitions: going from SBC Stop to SBC Sleep Mode. In this case the SBC additionally enters the SBC Restart Mode.
Trying to go to SBC Stop or SBC Sleep mode from SBC Init Mode. In this case SBC Normal Mode is entered.
- Uneven parity in the data bit of the **WD_CTRL** register. In this case either the watchdog trigger is ignored or the new watchdog settings are ignored.
- In SBC Stop Mode: attempting to change any SPI settings , e.g. changing the watchdog configuration during SBC Stop Mode.
the SPI command is ignored in this case.
The following are allowed in SBC Stop Mode: WD trigger, returning to SBC Normal Mode , triggering a SBC Soft Reset, set to SBC Stop Mode (to return from PWM to PFM following an automatic Buck mode transition) and Read & Clear status register commands are valid SPI commands in SBC Stop Mode.
- When entering SBC Stop Mode and **WK_STAT_0** and **WK_STAT_2** are not cleared; **SPI_FAIL** will not be set but the INTN pin will be triggered.
- When changing from SBC Stop to Normal Mode, any attempt to change the bits on the **M_S_CTRL** register will be ignored (SBC remains in SBC Stop Mode). Only **VIO_OV_RST** and **VIO_RT** set the **SPI_FAIL** bit.
- SBC Sleep Mode: attempt to go to Sleep Mode when all bits in the **BUS_CTRL_0**, **BUS_CTRL_2**, **BUS_CTRL_3** and **WK_CTRL_1** registers are cleared (i.e. no wake sources are activated). In this case the **SPI_FAIL** bit is set and the SBC enters SBC Restart Mode.
Even though the SBC Sleep Mode command is not entered in this case, the rest of the command (e.g modifying VEXT) is executed and the values stay unchanged during SBC Restart Mode.
Note: at least one wake source must be activated in order to avoid a deadlock situation in SBC Sleep Mode, i.e. the SBC would not be able to wake up anymore.
No failure handling occurs for the attempt to go to SBC Stop Mode when all bits in the registers **BUS_CTRL_0**, **BUS_CTRL_2**, **BUS_CTRL_3** and **WK_CTRL_1** are cleared because the microcontroller can leave this mode via SPI.
- After the first VEXT on command, the **VEXT_VCFG** bits can no longer be changed. if the microcontroller tries to modify the **VEXT_VCFG** bits, then the rest of the command is executed but **VEXT_VCFG** will remain unchanged.
- The Boost output voltage can be changed only if **BOOST_EN** is set to 0. If the Boost output voltage is changed with **BOOST_EN**=1, the **SPI_FAIL** bit is set and the SPI command is ignored.
- SDI stuck at HIGH or LOW, e.g. SDI received all '0' or all '1'.

Signalization of the ERR flag in the SPI data output (see [Figure 42](#)):

The ERR flag presents an additional diagnosis possibility for the SPI communication. The ERR flag is being set for the following conditions:

- In case the number of received SPI clocks is not 0 or 16.
- In case RSTN is LOW and SPI frames are being sent at the same time.

Serial Peripheral Interface

Note: In order to read the SPI ERR flag property, CLK must be low when CSN is triggered, i.e. the ERR bit is not valid if the CLK is high on a falling edge of CSN.

The number of received SPI clocks is not 0 or 16:

The number of received input clocks is supervised to be 0 or 16 clock cycles and the input word is discarded in case of a mismatch (0 clock cycle to enable ERR signalization). The error logic also recognizes if CLK was high during the CSN edges. Both errors, 0 bit and 16 bit CLK mismatch or CLK high during CSN edges are flagged in the following SPI output by a "HIGH" at the data output (SDO pin, bit ERR) before the first rising edge of the clock is received. The error logic also recognizes if CLK was HIGH during CSN edges. The entire SPI command is ignored in these cases.

RSTN is LOW and SPI frames are being sent at the same time:

The ERR flag will be set when the RSTN pin is triggered (during SBC Restart Mode) and SPI frames are being sent to the SBC at the same time. The behavior of the ERR flag signaled at the next SPI command when the condition below are present:

- If the command begins when RSTN is HIGH and ends when RSTN is LOW.
- If an SPI command is sent while RSTN is LOW.
- If an SPI command begins when RSTN is LOW and ends when RSTN is HIGH.

And the SDO output will behave as follows:

- When RSTN is LOW, SDO is always HIGH.
- When SPI command begins with RSTN is LOW and ends when RSTN is HIGH, then the SDO should be ignored because wrong data will be sent.

Note: It is possible to quickly check for the ERR flag without sending any data bits. i.e. only the CSN is pulled low and SDO is observed - no SPI clocks are sent in this case.

Note: The ERR flag could also be set after the SBC has entered SBC Fail-Safe Mode because SPI communication stops immediately.

Serial Peripheral Interface

13.3 SPI Programming

For TLE9278, 7 bits are used for the address selection (6...0). Bit 7 is used to control the SPI Access, i.e. to decide between Read Only (if set to '0') and Read_Clear (if set to '1') for the status bits, and between Write (if set to '1') and Read Only (if set to '0') for configuration bits. For the actual configuration and status information, 8 data bits (15...8) are used.

Writing, clearing and reading is done byte wise. SPI configuration and status bits are not cleared automatically and must be cleared by the microcontroller, e.g. if the TSD2 was set due to overtemperature. The configuration bits will be partially automatically cleared by the SBC (refer to the description of the individual registers for detailed information). During SBC Restart, Sleep or Fail-Safe mode, the SPI communication is ignored by the SBC, i.e. it is not interpreted.

There are two types of SPI registers:

- Control registers: Those are the registers to configure the SBC, e.g. SBC mode, watchdog trigger, etc.
- Status registers: Those are the registers where the status of the SBC is signalled, e.g. wake-up events, warnings, failures, etc.

For the status registers, the requested information is given in the same SPI command in DO.

For the control registers, also the status of the respective bit is shown in the same SPI command, but if the setting is changed this is only shown with the next SPI command (it is only valid after CSN HIGH) of the same register.

The SBC status information from the SPI status registers, is transmitted in a compressed way with each SPI response on SDO in the so called Status Information Field register (see also [Figure 43](#)).

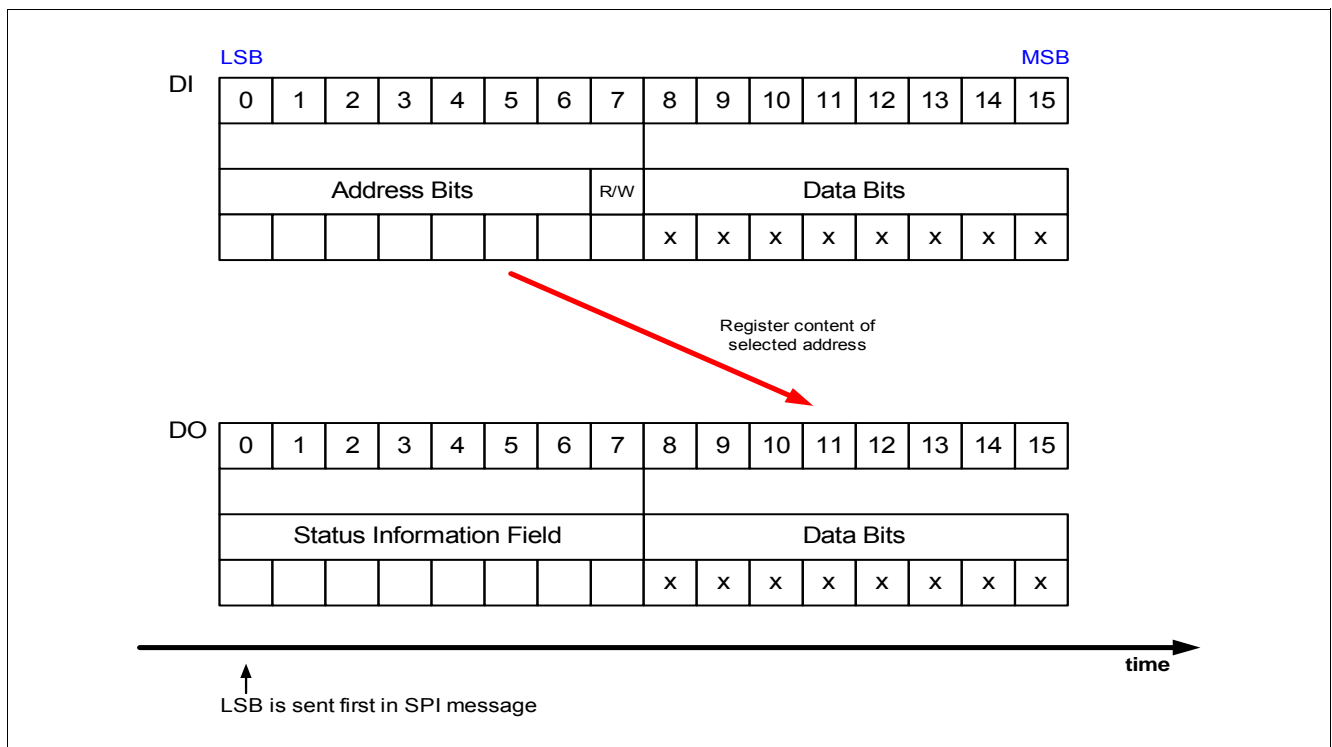

Figure 43 SPI Operation Mode

The purpose of this register is to quickly signal the information to the microcontroller if there was a change in one of the SPI status registers. In this way, the microcontroller does not need to read constantly all the SPI status registers but only those registers, which were changed. Each bit in the Status Information Field

Serial Peripheral Interface

represents a SPI status register or a combinational OR of two status registers (see **Table 24**). As soon as one bit is set in one of the status registers, the respective bit in the Status Information Field register is set. The register **WK_LVL_STAT** is not included in the status information field. This is listed in **Table 24**:

Table 24 Status Information Field

Status Information Bit	Symbol Address Bit	Status Register
0	100 0001	SUP_STAT_0 & SUP_STAT_1 (Combinational OR): Supply Status (VCC1 and VEXT), POR
1	100 0010	THERM_STAT : Thermal Protection Status
2	100 0011	DEV_STAT : Device Status - Mode before Wake, WD Fail, SPI Fail, Failure
3	100 0100	BUS_STAT_0 : Bus Failure Status: CAN0, VCAN
4	100 0101	BUS_STAT_2 & BUS_STAT_3 (Combinational OR): Bus Failure Status: CAN1, CAN2 and CAN3
5	100 0110	WK_STAT_0 : Wake Source Status for CAN0, WK, Timer and PFM-to-PWM transition
6	100 0111	WK_STAT_2 : Wake Source Status for CAN1, CAN2, CAN3, and VBAT_UV
7	100 1100	SMPS_STAT : SMPS Status

For example if bit 2 in the Status Information Field is set to 1, one or more bits of the register **DEV_STAT** is set to 1. Then this register needs to be read in a second SPI command. The bit in the Status Information Field will be set to 0 when all bits in the register **DEV_STAT** are set back to 0.

13.4 SPI Bit Mapping

13.4.1 SPI Mapping Structure

Figure 44 and **Figure 45** show the mapping of the SPI bits and the respective registers.

Depending on bit 7, the bits are only read or also written. The Control Registers '000 0001' to '011 1111' are READ/WRITE Registers.

The new setting of the bit after write can be seen with the next read / write command. .

The registers '100 0000' to '111 1110' are Status Registers and can be read or read with clearing the bit (if possible) depending on bit 7. To clear a Data Byte of one of the Status Registers, bit 7 must be set to 1. The register **WK_LVL_STAT** is an exception as it shows the actual voltage level at the respective pin (LOW/HIGH) and thus can not be cleared.

When changing to a different SBC Mode, certain configurations and status bits will be modified by the SBC:

- The SBC Mode bits are updated to the actual status, e.g. when returning to SBC Normal Mode.
- In SBC Sleep Mode the CANx control bits will be modified in CANx wake capable if they were ON before. FO will stay activated if it was triggered before.
- In general, the configurations is only possible in SBC Normal Mode. Diagnosis are also active in SBC Stop Mode (e.g. UV, OT). VEXT can be also active in Low power mode (Stop/Sleep).
- Depending on the respective configuration, CANx transceivers will be either OFF, woken or still wake capable.

Serial Peripheral Interface

13.4.2 SPI Mapping Tables

Register Short Name	banked	7	6...0
		Access Control	Address A6...A0
CONTROL REGISTERS			
M_S_CTRL	no	read/write	0000001
HW_CTRL_0	no	read/write	0000010
WD_CTRL	no	read/write	0000011
BUS_CTRL_0	no	read/write	0000100
WK_CTRL_0	no	read/write	0000110
WK_CTRL_1	no	read/write	0000111
WK_PD_CTRL	no	read/write	0001000
BUS_CTRL_2	no	read/write	0001010
BUS_CTRL_3	no	read/write	0001011
TIMER_CTRL	no	read/write	0001100
HW_CTRL_1	no	read/write	0001110
SYS_STAT_CTRL	no	read/write	0011110
STATUS REGISTERS			
SUP_STAT_1	no	read/clear	1000000
SUP_STAT_0	no	read/clear	1000001
THERM_STAT	no	read/clear	1000010
DEV_STAT	no	read/clear	1000011
BUS_STAT_0	no	read/clear	1000100
WK_STAT_0	no	read/clear	1000110
WK_LVL_STAT	no	read	1001000
WK_STAT_2	no	read/clear	1001001
BUS_STAT_2	no	read/clear	1001010
BUS_STAT_3	no	read/clear	1001011
SMPS_STAT	no	read/clear	1001100
ADC_STAT	no	read/clear	1011000
FAMILY AND PRODUCT REGISTERS			
FAM_PROD_STAT	no	read	1111110

Figure 44 SPI Register Mapping

Serial Peripheral Interface

Register Short Name	15	14	13	12	11	10	9	8	banked	Read-Only (1)
	Data Bit 15..8									
	D7	D6	D5	D4	D3	D2	D1	D0		
CONTROL REGISTERS										
M_S_CTRL	MODE_1	MODE_0	VEXT_ON	reserved	reserved	VIO_OV_RST	VIO_RT_1	VIO_RT_0	no	read/write
HW_CTRL_0	reserved	PWM_TLAG	FO_ON	PWM_BY_WK	PWM_AUTO	reserved	BOOST_EN	CFG2	no	read/write
WD_CTRL	CHECKSUM	WD_STM_EN_0	WD_WIN	WD_EN_WK_BUS	MAX_3_RST	WD_TIMER_2	WD_TIMER_1	WD_TIMER_0	no	read/write
BUS_CTRL_0	reserved	reserved	reserved	reserved	reserved	reserved	CAN0_1	CAN0_0	no	read/write
WK_CTRL_0	reserved	TIMER_WK_EN	VBSSENSE_CFG_1	VBSSENSE_CFG_0	reserved	WD_STM_EN_1	reserved	VBSSENSE_EN	no	read/write
WK_CTRL_1	reserved	reserved	reserved	reserved	reserved	reserved	reserved	WK_EN	no	read/write
WK_PUPD_CTRL	reserved	reserved	reserved	reserved	reserved	reserved	WK_PUPD_1	WK_PUPD_0	no	read/write
BUS_CTRL_2	CAN_2_FLASH	CAN_1_FLASH	reserved	CAN2_1	CAN2_0	reserved	CAN1_1	CAN1_0	no	read/write
BUS_CTRL_3	reserved	reserved	reserved	CAN_0_FLASH	CAN_3_FLASH	reserved	CAN3_1	CAN3_0	no	read/write
TIMER_CTRL_0	reserved	reserved	reserved	reserved	reserved	TIMER_PER_2	TIMER_PER_1	TIMER_PER_0	no	read/write
HW_CTRL_1	reserved	SOFT_RESET_RST	BST_VB_UV_OFF	reserved	BOOST_V_1	BOOST_V_0	VEXT_VCFG_1	VEXT_VCFG_0	no	read/write
SYS_STAT_CTRL	SYS_STAT_7	SYS_STAT_6	SYS_STAT_5	SYS_STAT_4	SYS_STAT_3	SYS_STAT_2	SYS_STAT_1	SYS_STAT_0	no	read/write
STATUS REGISTERS										
SUP_STAT_1	BVB_UV_BST	VS_UV	reserved	VEXT_OC	VREG_UV	VEXT_OT	VIO_OV	VIO_WARN	no	read/clear
SUP_STAT_0	POR	reserved	reserved	reserved	reserved	VIO_SC	VIO_UV_FS	VIO_UV	no	read/clear
THERM_STAT	reserved	VCC1_OT	BOOST_OT	reserved	reserved	TSD2	TSD1	TPW	no	read/clear
DEV_STAT	DEV_STAT_1	DEV_STAT_0	reserved	reserved	WD_FAIL_1	WD_FAIL_0	SPI_FAIL	FO_ON_STATE	no	read/clear
BUS_STAT_0	reserved	reserved	reserved	reserved	reserved	CAN_0_FAIL_1	CAN_0_FAIL_0	VCAN_UV	no	read/clear
WK_STAT_0	PFM_PWM	reserved	CAN_0_WU	TIMER_WU	reserved	reserved	reserved	WK_WU	no	read/clear
WK_LVL_STAT	TEST	CFG1_STATE	CFG2_STATE	PCFG_STATE	VBAT_UV_STATE	reserved	reserved	WK	no	read
WK_STAT_2	VBAT_UV_LATCH	reserved	reserved	reserved	reserved	CAN_3_WU	CAN_2_WU	CAN_1_WU	no	read/clear
BUS_STAT_2	reserved	reserved	CAN_2_FAIL_1	CAN_2_FAIL_0	reserved	reserved	CAN_1_FAIL_1	CAN_1_FAIL_0	no	read/clear
BUS_STAT_3	reserved	reserved	reserved	reserved	reserved	reserved	CAN_3_FAIL_1	CAN_3_FAIL_0	no	read/clear
SMPS_STAT	BST_ACT	BST_SH	BST_OP	reserved	reserved	BCK_SH	BCK_OP	reserved	no	read/clear
FAMILY AND PRODUCT REGISTERS										
FAM_PROD_STAT	FAM_3	FAM_2	FAM_1	FAM_0	PROD_3	PROD_2	PROD_1	PROD_0	no	read

Figure 45 Detailed SPI Bit Mapping

13.5 SPI Control Registers

Read / Write Operation (see [Chapter 13.3](#)):

- The 'POR / Soft Reset Value' defines the register content after POR or SBC Software Reset.
- The 'Restart Value' defines the register content after SBC Restart; 'x' means the bit is unchanged.
- 'y' in 'Restart Value' means the bit can be changed by SBC.
- One 16-bit SPI command consist of two bytes:
 - the 7-bit address and one additional bit for the register access mode and
 - following the data byteThe numbering of following bit definitions refers to the data byte and correspond to the bits D0...D7 and to the SPI bits 8...15.
- There are three different bit types:
 - 'r' = READ; read only bits (or reserved bits).
 - 'rw' = READ/WRITE; readable and writable bits.
 - 'rwh' = READ/WRITE/HARDWARE; as **rw** with the possibility that the hardware can change the bits.
- Reading a register is done byte wise by setting the SPI bit 7 to "0" (= Read Only).
- Writing to a register is done byte wise by setting the SPI bit 7 to "1".
- SPI control bits are not cleared or changed automatically. This must be done by the microcontroller via SPI programming.

The registers are addressed wordwise.

13.5.1 General Control Registers

Serial Peripheral Interface

Mode- and Supply Control

M_S_CTRL

Mode- and Supply Control (Address 000 0001_B)

POR / Soft Reset Value: 0000 0000_B; Restart Value: 00x0 00xx_B

7	6	5	4	3	2	1	0
MODE		VEXT_ON	Reserved		VIO_OV_RST	VIO_RT	
rwh		rw	r		rwh	rw	

Field	Bits	Type	Description
MODE	7:6	rwh	SBC Mode Control 00 _B SBC Normal Mode 01 _B SBC Sleep Mode 10 _B SBC Stop Mode 11 _B SBC Reset: Soft Reset is executed (configuration of RSTN triggering in bit SOFT_RESET_RSTN)
VEXT_ON	5	rw	VEXT Mode Control 0 _B VEXT OFF 1 _B VEXT is enabled
Reserved	4:3	r	Reserved, always reads as 0
VIO_OV_RST	2	rwh	VIO Overvoltage Reset / Fail-Safe enable 0 _B VIO_OV is set in case of VIO_OV; no SBC Restart or Fail-Safe is entered for VIO_OV 1 _B VIO_OV is set in case of VIO_OV; depending on the device configuration SBC Restart or SBC Fail-Safe Mode is entered (see Chapter 5.1.1);
VIO_RT	1:0	rw	VIO Reset Threshold Control 00 _B Vrt1 selected (highest threshold) 01 _B Vrt2 selected 10 _B Vrt3 selected 11 _B Vrt4 selected

Notes

1. It is not possible to change from SBC Stop to Sleep Mode via an SPI Command. See also the State Machine Chapter.
2. After entering SBC Restart Mode, the MODE bits will be automatically set to SBC Normal Mode.
3. The SPI output will always show the previously written state with a Write Command (what has been programmed before).

Serial Peripheral Interface

Hardware Control 0

HW_CTRL_0

Hardware Control 0 (Address 000 0010_B)

POR / Soft Reset Value: 0000 0000_B; Restart Value: 0x0x xxxx_B

7	6	5	4	3	2	1	0
Reserved	PWM_TLAG	FO_ON	PWM_BY_WK	PWM_AUTO	Reserved	BOOST_EN	CFG2
r	rw	rwh	rwh	rw	r	rwh	rw

Field	Bits	Type	Description
Reserved	7	r	Reserved, always reads as 0
PWM_TLAG	6	rw	PWM Lag time This bit permits to set the time between the PWM to PFM transition. 0 _B 100µs 1 _B 1ms
FO_ON	5	rwh	Failure Output activation This bit is used to activate the Fail Output by software. 0 _B FO not activated by software, FO can be activated by defined failure 1 _B FO activated by software.
PWM_BY_WK	4	rwh	PWM of Buck converter enabled by WK pin 0 _B Buck converter uses PFM in SBC Stop Mode 1 _B Buck converter can be switched between PFM and PWM by the WK pin in SBC Stop Mode.
PWM_AUTO	3	rw	Automatic transition PFM-PWM in SBC Stop Mode This bit is used to activate the automatic transition PFM to PWM. 0 _B Buck converter always uses PFM in SBC Stop Mode (default) 1 _B Buck converter uses automatic transition PFM to PWM in case large current needed in SBC Stop Mode. To come back in PFM, write a SBC Stop Mode command to M_S_CTRL .
Reserved	2	r	Reserved, always reads as 0
BOOST_EN	1	rwh	Boost converter enable 0 _B Boost Off 1 _B Boost enabled, automatic switch ON for LOW V _S Voltage
CFG2	0	rw	Configuration Select 2 0 _B Fail Output (FO) enabled after 2nd watchdog trigger fail Config 3/4 1 _B Fail Output (FO) enabled after 1st watchdog trigger fail Config 1/2

Notes

1. The FO_ON bit is cleared by the SBC after SBC Restart Mode. Clearing the bit via SPI or via SBC Restart Mode will not disable the FO output, if the failure condition is still present. See also [Chapter 11](#) for FO activation and deactivation. Setting the FO output via an SPI should be used for testing purposes only.
2. The selection between Config 1/3 respectively Config 2/4 is done by the pin INTN. The INTN pin defines if the SBC enters to SBC Fail-Safe Mode with VCC1 OFF in case of a watchdog failure.

Serial Peripheral Interface

Watchdog Control

WD_CTRL

Watchdog Control (Address 000 0011_B)

POR / Soft Reset Value: 0001 0100_B; Restart Value: x0xx x100_B

7	6	5	4	3	2	1	0
CHECKSUM	WD_STM_EN _0	WD_WIN	WD_EN_WK_ BUS	MAX_3_RST	WD_TIMER		
rw	rwh	rw	rw	rw	rwh		

Field	Bits	Type	Description
CHECKSUM	7	rw	Watchdog Setting Checksum Bit The sum of bits 7:0 needs to have even parity 0 _B Counts as 0 for checksum calculation 1 _B Counts as 1 for checksum calculation
WD_STM_EN_0	6	rwh	Watchdog Deactivation during SBC Stop Mode, bit 0 (Chapter 12.2.4) 0 _B Watchdog is active in Stop Mode 1 _B Watchdog is deactivated in Stop Mode
WD_WIN	5	rw	Watchdog Type Selection 0 _B Watchdog works as a Time-Out watchdog 1 _B Watchdog works as a Window watchdog
WD_EN_WK_BUS	4	rw	Watchdog Enable after Bus (CANx) Wake in SBC Stop Mode 0 _B Watchdog will not start after a CANx wake 1 _B Watchdog starts with a long open window after CANx Wake
MAX_3_RST	3	rw	Limit number of resets due to a Watchdog failure 0 _B Always generate a reset in case of WD fail 1 _B After 3 consecutive resets due to WD fail, no further reset is generated (only valid in config 1/3)
WD_TIMER	2:0	rwh	Watchdog Timer Period 000 _B 10ms 001 _B 20ms 010 _B 50ms 011 _B 100ms 100 _B 200ms 101 _B 500ms 110 _B 1000ms 111 _B reserved

Notes

1. See [Chapter 12.2.3](#) for calculating the checksum.
2. See also [Chapter 12.2.4](#) for more information on disabling the watchdog in SBC Stop Mode.
3. See [Chapter 12.2.4](#) for more information on the effect of the bit WD_EN_WK_BUS.

Serial Peripheral Interface

Bus Control 0

BUS_CTRL_0

Bus Control 0 (Address 000 0100_B)

POR / Soft Reset Value: 0000 0000_B; Restart Value: 0000 00yy_B

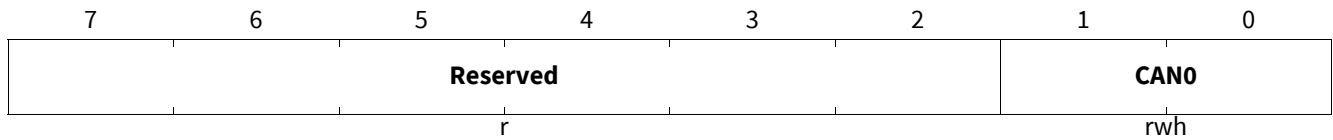

Field	Bits	Type	Description
Reserved	7:2	r	Reserved, always reads as 0
CAN0	1:0	rwh	HS-CAN_0 Module Modes 00 _B CAN OFF 01 _B CAN is wake capable 10 _B CAN Receive Only Mode 11 _B CAN Normal Mode

Notes

1. See [Figure 18](#) for detailed state changes of the CAN Transceiver for different SBC modes.
2. *Failure Handling Mechanism: When the SBC enters SBC Fail-Safe Mode due to a failure (e.g. TSD2, WD-Failure), then the bus and wake registers are modified by the SBC in order to ensure that the device can be woken again. Refer to the respective register descriptions.*

Serial Peripheral Interface

Internal Wake Input Control 0

WK_CTRL_0

Internal Wake Input Control 0 (Address 000 0110_B)

POR / Soft Reset Value: 0000 0001_B; Restart Value: 0xxx 000x_B

7	6	5	4	3	2	1	0
Reserved	TIMER1_WK_EN	VBSENSE_CFG		Reserved	WD_STM_EN_1	Reserved	VBSENSE_EN
r	rw	rw		r	rwh	r	rw

Field	Bits	Type	Description
Reserved	7	r	Reserved, always reads as 0
TIMER1_WK_EN	6	rw	Wake Source Control (for cyclic wake) 0 _B Cyclic wake disabled 1 _B Cyclic wake enabled as a wake source
VBSENSE_CFG	5:4	rw	Battery Voltage Monitoring Threshold Selection 00 _B VBSENSE0 threshold selected (highest threshold) 01 _B VBSENSE1 threshold selected 10 _B VBSENSE2 threshold selected 11 _B VBSENSE3 threshold selected
Reserved	3	r	Reserved, always reads as 0
WD_STM_EN_1	2	rwh	Watchdog Deactivation during Stop Mode, bit 1 (Chapter 12.2.4) 0 _B Watchdog is active in Stop Mode 1 _B Watchdog is deactivated in Stop Mode
Reserved	1	r	Reserved, always reads as 0
VBSENSE_EN	0	rw	Enable the fast battery voltage monitoring 0 _B Fast Vbatt Monitoring disabled 1 _B Fast Vbatt Monitoring enabled

Note: See also [Chapter 12.2.4](#) for more information on disabling the watchdog in SBC Stop Mode.

Serial Peripheral Interface

External Wake Source Control 1

WK_CTRL_1

External Wake Source Control 1 (Address 000 0111_B)

POR / Soft Reset Value: 0000 0001_B; Restart Value: 0000 000x_B

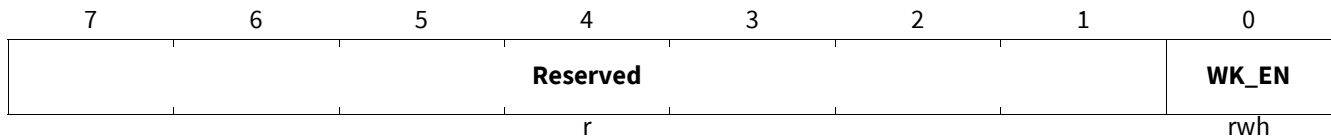

Field	Bits	Type	Description
Reserved	7:1	r	Reserved, always reads as 0
WK_EN	0	rwh	WK Wake Source Control 0 _B WK wake disabled 1 _B WK is enabled as a wake source

Notes

1. *Failure Handling Mechanism: When the device enters SBC Fail-Safe Mode due to a failure (e.g. TSD2, WD-Failure), the **WK_CTRL_1** is modified to the value '0000 0001' in order to ensure that the device can be woken again.*

Serial Peripheral Interface

Wake Input Level Control

WK_PUPD_CTRL

Wake Input Level Control (Address 000 1000_B)

POR / Soft Reset Value: 0000 0000_B; Restart Value: 0000 00xx_B

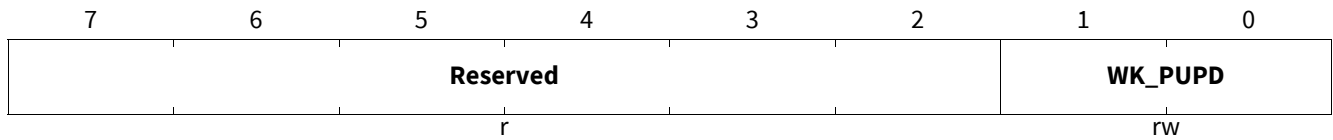

Field	Bits	Type	Description
Reserved	7:2	r	Reserved, always reads as 0
WK_PUPD	1:0	rw	WK Pull-Up / Pull-Down Configuration 00 _B No pull-up / pull-down selected 01 _B Pull-down resistor selected 10 _B Pull-up resistor selected 11 _B Automatic switching to pull-up or pull-down

Serial Peripheral Interface

Bus Control 2

BUS_CTRL_2

Bus Control 2 (Address 000 1010_B)

POR / Soft Reset Value: 0000 0000_B; Restart Value: xx0y y0yy_B

7	6	5	4	3	2	1	0
CAN_2_Flash	CAN_1_Flash	Reserved	CAN2		Reserved	CAN1	
rw	rw	r	rwh		r	rwh	

Field	Bits	Type	Description
CAN_2_Flash	7	rw	CAN2 Flash Mode activation 0 _B Flash Mode disabled: CAN communication up to 5MBaud 1 _B Flash Mode enabled: CAN communication for higher than 5MBaud (higher emission on CAN bus - no slew rate control)
CAN_1_Flash	6	rw	CAN1 Flash Mode activation 0 _B Flash Mode disabled: CAN communication up to 5MBaud 1 _B Flash Mode enabled: CAN communication for higher than 5MBaud (higher emission on CAN bus - no slew rate control)
Reserved	5	r	Reserved, always reads as 0
CAN2	4:3	rwh	HS-CAN_2 Module Modes 00 _B CAN OFF 01 _B CAN is wake capable 10 _B CAN Receive Only Mode 11 _B CAN Normal Mode
Reserved	2	r	Reserved, always reads as 0
CAN1	1:0	rwh	HS-CAN_1 Module Modes 00 _B CAN OFF 01 _B CAN is wake capable 10 _B CAN Receive Only Mode 11 _B CAN Normal Mode

Notes

1. See [Figure 18](#) for detailed state changes of the CAN Transceiver for different SBC modes.
2. Failure Handling Mechanism: When the device enters SBC Fail-Safe Mode due to a failure (e.g. TSD2, WD-Failure), then the bus and wake registers are modified by the SBC in order to ensure that the device can be woken again. Refer to the respective register descriptions.

Serial Peripheral Interface

Timer_0 Control and Selection

TIMER_CTRL_0

Timer_0 Control and Selection (Address 000 1100_B)

POR / Soft Reset Value: 0000 0000_B; Restart Value: 0000 0000_B

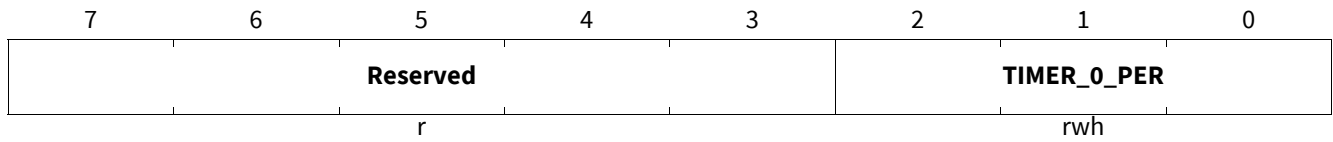

Field	Bits	Type	Description
Reserved	7:3	r	Reserved, always reads as 0
TIMER_0_PER	2:0	rwh	Cyclic Wake Period Configuration 000 _B 10ms 001 _B 20ms 010 _B 50ms 011 _B 100ms 100 _B 200ms 101 _B 1s 110 _B 2s 111 _B reserved

Serial Peripheral Interface

Hardware Control 1

HW_CTRL_1

Hardware Control 1 (Address 000 1110_B)

POR / Soft Reset Value: 0000 00yy_B; Restart Value: 0x0x xxxx_B

7	6	5	4	3	2	1	0
ADC_SEL	SOFT_RESET_RSTN	BST_VB_UV_OFF	Reserved	BOOST_V		VEXT_VCFG	
rw	rw	rw	r	rw		rwh	

Field	Bits	Type	Description
ADC_SEL	7	rw	8 bit ADC input channel selector 0 _B WK pin is selected 1 _B VBSENSE pin is selected
SOFT_RESET_RSTN	6	rw	Soft Reset Configuration 0 _B RSTN will be triggered (pulled low) during a Soft Reset (default) 1 _B No RSTN triggering during a Soft Reset
BST_VB_UV_OFF	5	rw	Boost switch-off control on VBSENSE low voltage condition 0 _B Boost automatic switch-off disable 1 _B Boost automatic switch-off enable
Reserved	4	r	Reserved, always reads as 0
BOOST_V	3:2	rw	BOOST Output voltage configuration 00 _B 6.7V output (default) 01 _B 8V output 10 _B 10V output 11 _B 12V output
VEXT_VCFG	1:0	rwh	VEXT Output voltage configuration 00 _B 5.0V output 01 _B 3.3V output (default) 10 _B 1.8V output 11 _B 1.2V output

Notes

1. After triggering a SBC Software Reset the bits **VEXT_VCFG** remain unchanged, as shown by the 'y' in the POR/Soft Reset Value.
2. The **VEXT_VCFG** can not be accessed if the PCFG pin is connected to GND. Always read '01'.

Serial Peripheral Interface

Bus Control 3

BUS_CTRL_3

Bus Control 3 (Address 000 1011_B)

POR / Soft Reset Value: 0000 0000_B; Restart Value: 000x x0yy_B

7	6	5	4	3	2	1	0
Reserved			CAN_0_Flash	CAN_3_Flash	Reserved	CAN3	
r			rw	rw	r	rwh	

Field	Bits	Type	Description
Reserved	7:5	r	Reserved, always reads as 0
CAN_0_Flash	4	rw	CAN0 Flash Mode activation 0 _B Flash Mode disabled: CAN communication up to 5MBaud 1 _B Flash Mode enabled: CAN communication for higher than 5MBaud (higher emission on CAN bus - no slew rate control)
CAN_3_Flash	3	rw	CAN3 Flash Mode activation 0 _B Flash Mode disabled: CAN communication up to 5MBaud 1 _B Flash Mode enabled: CAN communication for higher than 5MBaud (higher emission on CAN bus - no slew rate control)
Reserved	2	r	Reserved, always reads as 0
CAN3	1:0	rwh	HS-CAN_3 Module Modes 00 _B CAN OFF 01 _B CAN is wake capable 10 _B CAN Receive Only Mode 11 _B CAN Normal Mode

Notes

1. See [Figure 18](#) for detailed state changes of CAN Transceiver for different SBC modes.
2. Failure Handling Mechanism: When the device enters Fail-Safe Mode due to a failure (e.g. TSD2, WD-Failure), then the bus and wake registers are modified by the SBC in order to ensure that the device can be woken again. Refer to the respective register descriptions.

Serial Peripheral Interface

System Status Control

SYS_STATUS_CTRL

System Status Control (Address 001 1110_B)

POR Value: 0000 0000_B; Restart Value/Soft Reset Value: xxxx xxxx_B

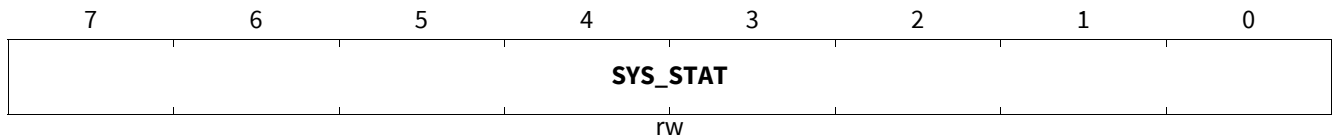

Field	Bits	Type	Description
SYS_STAT	7:0	rw	System Status Control Byte (bit0=LSB; bit7=MSB) Dedicated byte for system configuration, access only by microcontroller

Notes

1. The **SYS_STATUS_CTRL** register is an exception for the default values, i.e. it will keep its configured value even after a Software Reset.
2. This byte is intended for storing system configurations of the ECU by the microcontroller and is only accessible in SBC Normal Mode. The byte is not accessible by the SBC and is also not cleared after SBC Fail-Safe or Restart Mode. It allows the microcontroller to quickly store the system configuration without losing the data.

13.6 SPI Status Information Registers

Read/Clear Operation (see [Chapter 13.3](#)):

- One 16-bit SPI command consist of two bytes:
 - the 7-bit address and one additional bit for the register access mode and
 - following the data byte will be ignored when accessing a status registerThe numbering of following bit definitions refers to the data byte and correspond to the bits D0...D7 and to the SPI bits 8...15.
- There are three different bit types:
 - 'r' = READ: read only bits (or reserved bits)
 - 'rc' = READ/CLEAR: readable and clearable bits
 - 'rh' = READ/HARDWARE: readable and the possibility that the hardware can change the bits
- Reading a register is done byte wise by setting the SPI bit 7 to "0" (= Read Only)
- Clearing a register is done byte wise by setting the SPI bit 7 to "1"
- SPI status registers are in general not cleared or changed automatically (an exception are the [WD_FAIL](#) bits). This must be done by the microcontroller via SPI command

The registers are addressed wordwise.

Serial Peripheral Interface

13.6.1 General Status Registers

Supply Voltage Fail Status 1

SUP_STAT_1

Supply Voltage Fail Status 1 (Address 100 0000_B)

POR / Soft Reset Value: 0000 0000_B; Restart Value: xx0x xxxx_B

7	6	5	4	3	2	1	0
VB_UV_BST	VS_UV	Reserved	VEXT_OC	VREG_UV	VEXT_OT	VIO_OV	VIO_WARN
rc	rc	r	rc	rc	rc	rc	rc

Field	Bits	Type	Description
VB_UV_BST	7	rc	VBSense low voltage detection 0 _B No VBSense low voltage detected 1 _B VBSense low voltage detected
VS_UV	6	rc	VS Undervoltage Detection ($V_{S,uv}$) 0 _B No V_S undervoltage detected 1 _B V_S undervoltage detected
Reserved	5	r	Reserved, always reads as 0
VEXT_OC	4	rc	VEXT Overcurrent Detection 0 _B No OC 1 _B OC detected
VREG_UV	3	rc	The status is related to VEXT 0 _B No VEXT UV detection 1 _B VEXT UV Fail detected
VEXT_OT	2	rc	VEXT Overtemperature Detection 0 _B No overtemperature 1 _B VEXT overtemperature detected
VIO_OV	1	rc	VIO Overvoltage Detection ($V_{IO,ov,r}$) 0 _B No VIO overvoltage warning 1 _B VIO overvoltage detected
VIO_WARN	0	rc	VIO Undervoltage Prewarning ($V_{PW,f}$) 0 _B No VIO undervoltage prewarning 1 _B VIO undervoltage prewarning detected

Notes

1. The VIO undervoltage prewarning threshold $V_{PW,f}$ is a fixed threshold and independent of the VIO undervoltage reset thresholds.
2. VIO_WARN bit setting: It is never updated in SBC Restart Mode. In SBC Init Mode it is only updated after RSTN was released for the first time. It is always updated in SBC Normal and Stop Mode. It is never updated in SBC Sleep Mode and it is always updated in any SBC modes in a VIO_SC condition (after $VIO_UV = 1$ longer than $t_{vio,sc}$).

Serial Peripheral Interface

Supply Voltage Fail Status 0

SUP_STAT_0

Supply Voltage Fail Status 0 (Address 100 0001_B)

POR / Soft Reset Value: y000 0000_B; Restart Value: x000 0xxx_B

7	6	5	4	3	2	1	0
POR	Reserved				VIO_SC	VIO_UV_FS	VIO_UV
rc	r				rc	rc	rc

Field	Bits	Type	Description
POR	7	rc	Power-On Reset Detection 0 _B No POR 1 _B POR occurred
Reserved	6:3	r	Reserved, always reads as 0
VIO_SC	2	rc	VIO Short to GND Detection 0 _B No short 1 _B VIO short to GND detected
VIO_UV_FS	1	rc	VIO UV-Detection (due to VRTx reset) 0 _B No Fail-Safe Mode entry due to 4th consecutive VIO_UV 1 _B Fail-Safe Mode entry due to 4th consecutive VIO_UV
VIO_UV	0	rc	VIO UV-Detection (due to VRTx reset) 0 _B No VIO_UV detection 1 _B VIO UV-Fail detected

Notes

1. The MSB of the POR/Soft Reset value is marked as 'y': the default value of the POR bit is set after Power-on reset (POR value = 1000 0000). However it will be cleared after a SBC Software Reset command (Soft Reset value = 0000 0000).
2. During SBC Sleep Mode, the bits VIO_SC, VIO_OV and VIO_UV will not be set because the regulator supplying VIO is off.
3. The VIO_UV bit is never updated in SBC Restart Mode. In SBC Init Mode, it is only updated after RSTN was released for the first time. It is always updated in SBC Normal and Stop Mode, and it is always updated in any SBC modes in a VIO_SC condition (after VIO_UV = 1 longer than $t_{vio,sc}$).

Serial Peripheral Interface

Thermal Protection Status

THERM_STAT

Thermal Protection Status (Address 100 0010_B)

POR / Soft Reset Value: 0000 0000_B; Restart Value: 0xx0 0xxx_B

7	6	5	4	3	2	1	0
Reserved	VCC1_OT	BOOST_OT	Reserved		TSD2	TSD1	TPW
r	rc	rc	r		rc	rc	rc

Field	Bits	Type	Description
Reserved	7	r	Reserved, always reads as 0
VCC1_OT	6	rc	VCC1 Overtemperature detection 0 _B No VCC1 overtemperature 1 _B VCC1 overtemperature detected
BOOST_OT	5	rc	Boost Overtemperature detection 0 _B No Boost overtemperature 1 _B Boost overtemperature detected
Reserved	4:3	r	Reserved, always reads as 0
TSD2	2	rc	TSD2 Thermal Shut-Down Detection 0 _B No TSD2 event 1 _B TSD2 OT detected - leading to SBC Fail-Safe Mode
TSD1	1	rc	TSD1 Thermal Shut-Down Detection 0 _B No TSD1 fail 1 _B TSD1 OT detected
TPW	0	rc	Thermal Pre Warning 0 _B No Thermal Pre warning 1 _B Thermal Pre warning detected

Note: TPW, TSD1 and TSD2 are not reset automatically, even if the overtemperature pre warning or TSD1/2 conditions are not longer present.

Serial Peripheral Interface

Device Information Status

DEV_STAT

Device Information Status (Address 100 0011_B)

POR / Soft Reset Value: 0000 0000_B; Restart Value: xx00 xxxx_B

7	6	5	4	3	2	1	0
DEV_STAT		Reserved		WD_FAIL		SPI_FAIL	FO_ON_STAT E
rc		r		rh		rc	rc

Field	Bits	Type	Description
DEV_STAT	7:6	rc	Device Status before Restart Mode 00 _B Cleared (Register must be actively cleared) 01 _B Restart due to failure described in Table 8 and Table 9 . 10 _B Sleep Mode 11 _B Reserved
Reserved	5:4	r	Reserved, always reads as 0
WD_FAIL	3:2	rh	Number of WD-Failure Events (1/2 WD failures depending on INTN) 00 _B No WD Fail 01 _B 1x WD Fail, FOx activation- Config 1/2 10 _B 2x WD Fail, FOx activation- Config 3/4 11 _B Reserved (never reached)
SPI_FAIL	1	rc	SPI Fail Information 0 _B No SPI fail 1 _B Invalid SPI command detected
FO_ON_STATE	0	rc	Activation of Fail Output FO 0 _B No Failure 1 _B Failure occurred, FO is activated

Notes

- The **WD_FAIL** bits are configured as a counter and are the only status bits, which are cleared automatically by the SBC. They are cleared after a successful watchdog trigger and when the watchdog is stopped (also in SBC Sleep and Fail-Safe Mode unless it was reached due to a watchdog failure). See also [Chapter 11.1](#).
- The **SPI_FAIL** bit is cleared only by SPI command.
- With Config 2/4, the **WD_Fail** counter is frozen in case of WD trigger failure until a successful WD trigger occurs.

Serial Peripheral Interface

Bus Communication Status 0

BUS_STAT_0

Bus Communication Status 0 (Address 100 0100_B)

POR / Soft Reset Value: 0000 0000_B; Restart Value: 0000 0xxx_B

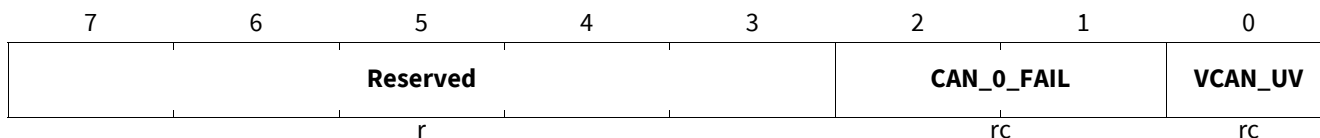

Field	Bits	Type	Description
Reserved	7:3	r	Reserved, always reads as 0
CAN_0_FAIL	2:1	rc	CAN_0 Failure Status 00 _B No error 01 _B CAN TSD shutdown 10 _B CAN_TXD_DOM: TXD dominant time out for more than 2ms 11 _B CAN_BUS_DOM: BUS dominant time out for more than 2ms
VCAN_UV	0	rc	Undervoltage CAN Bus Supply 0 _B Normal operation 1 _B CAN Supply undervoltage detected. Transmitter disabled

Notes

1. CAN0 Recovery Conditions:
 - 1.) TXD Time Out: TXDCAN0 goes HIGH or transmitter is switched off or the transceiver is wake capable.
 - 2.) Bus dominant time out: Bus will become recessive or transceiver is set to wake capable or switched off.
 - 3.) Supply undervoltage: as soon as the threshold is crossed again, i.e. VCAN > VCAN_UV.
 - 4.) In all cases (also for TSD shutdown): to enable the Bus transmission again, TXDCAN0 needs to be HIGH for a certain time (transmitter enable time).
2. The VCAN_UV comparator is enabled if the mode bit CANx_1 = '1', i.e. in CAN Normal or CAN Receive Only Mode.

Serial Peripheral Interface

Wake-up Source and Information Status 0

WK_STAT_0

Wake-up Source and Information Status 0 (Address 100 0110_B)

POR / Soft Reset Value: 0000 0000_B; Restart Value: x0xx 000x_B

7	6	5	4	3	2	1	0
PFM_PWM	Reserved	CAN_0_WU	TIMER_0_WU	Reserved		WK_WU	
rc	r	rc	rc	r		rc	

Field	Bits	Type	Description
PFM_PWM	7	rc	PFM_PWM automatic transition detected 0 _B No automatic PFM_PWM transition detected 1 _B Automatic PFM_PWM transition detected
Reserved	6	r	Reserved, always reads as 0
CAN_0_WU	5	rc	Wake up via CAN_0 Bus 0 _B No Wake up 1 _B Wake up
TIMER_0_WU	4	rc	Wake up via cyclic wake 0 _B No Wake up 1 _B Wake up
Reserved	3:1	r	Reserved, always reads as 0
WK_WU	0	rc	Wake up via WK 0 _B No Wake up 1 _B Wake up

Note: The respective wake source bit will also be set when the device is woken from SBC Fail-Safe Mode.

Serial Peripheral Interface

WK Input Level

WK_LVL_STAT

WK Input Level (Address 100 1000_B)

POR / Soft Reset Value: xx0x 000x_B; Restart Value: xxxx x00x_B

7	6	5	4	3	2	1	0
TEST	CFG1_STATE	CFG2_STATE	PCFG_STATE	VBAT_UV_STATE	Reserved		WK
r	r	r	r	r	r		r

Field	Bits	Type	Description
TEST	7	r	Status of Software Development Mode 0 _B LOW Level (=0), Normal User Operation, Software Development Mode is disabled 1 _B HIGH Level (=1), Software Development Mode is enabled, no reset triggered due to wrong Watchdog trigger
CFG1_STATE	6	r	Status of INTN Pin This bit shows the level of the INTN pin regarding the device configuration 0 _B LOW Level; Fail-Safe Mode entered due to WD failure (1 or 2 failure) depending on CFG2 bit) Config 2/4 1 _B HIGH Level; Fail-Safe Mode not entered, due to WD failure, Config 1/3
CFG2_STATE	5	r	Status of CFG2 bit on HW_CTRL_0 register This bit shows the setting in bit CFG2 0 _B LOW Level (=0), Fail Outputs (FOx) are active after 2nd watchdog trigger fail Config 3/4 1 _B HIGH Level (=1); Fail Outputs (FOx) are active after 1st watchdog trigger fail Config 1/2
PCFG_STATE	4	r	Status of PCFG Pin 0 _B LOW Level; (connected to GND) 1 _B HIGH Level; (left OPEN)
VBAT_UV_STATE	3	r	VBSENSE Undervoltage Detection Status 0 _B No VBSENSE undervoltage detected 1 _B VBSENSE undervoltage detected
Reserved	2:1	r	Reserved, always reads as 0
WK	0	r	Status of WK 0 _B LOW Level (=0) 1 _B HIGH Level (=1)

Serial Peripheral Interface

Wake-up Source and Information Status 2

WK_STAT_2

Wake-up Source and Information Status 2 (Address 100 1001_B)

POR / Soft Reset Value: 0000 0000_B; Restart Value: x000 0xxx_B

7	6	5	4	3	2	1	0
VBAT_UV_LA TCH	Reserved			CAN_3_WU		CAN_2_WU	CAN_1_WU
rc	r			rc		rc	rc

Field	Bits	Type	Description
VBAT_UV_LATCH	7	rc	VBSENSE Undervoltage Detection 0 _B No VBSENSE undervoltage detected 1 _B VBSENSE undervoltage detected (latched status)
Reserved	6:3	r	Reserved, always reads as 0
CAN_3_WU	2	rc	Wake up via CAN_3 Bus 0 _B No wake up 1 _B Wake up
CAN_2_WU	1	rc	Wake up via CAN_2 Bus 0 _B No wake up 1 _B Wake up
CAN_1_WU	0	rc	Wake up via CAN_1 Bus 0 _B No wake up 1 _B Wake up

Note: The respective wake source bit will also be set when the device is woken from SBC Fail-Safe Mode.

Serial Peripheral Interface

Bus Communication Status 2

BUS_STAT_2

Bus Communication Status 2 (Address 100 1010_B)

POR / Soft Reset Value: 0000 0000_B; Restart Value: 00xx 00xx_B

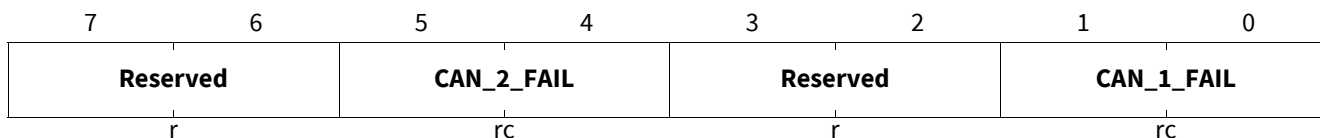

Field	Bits	Type	Description
Reserved	7:6	r	Reserved, always reads as 0
CAN_2_FAIL	5:4	rc	CAN_2 Failure Status 00 _B No error 01 _B CAN TSD shutdown 10 _B CAN_TXD_DOM: TXD dominant time out for more than 2ms 11 _B CAN_BUS_DOM: BUS dominant time out for more than 2ms
Reserved	3:2	r	Reserved, always reads as 0
CAN_1_FAIL	1:0	rc	CAN_1 Failure Status 00 _B No error 01 _B CAN TSD shutdown 10 _B CAN_TXD_DOM: TXD dominant time out for more than 2ms 11 _B CAN_BUS_DOM: BUS dominant time out for more than 2ms

Notes

1. CAN Recovery Conditions:

- 1.) TXD Time Out: TXDCANx goes HIGH or transmitter is switched off or the transceiver is wake capable.*
- 2.) Bus dominant time out: Bus will become recessive or transceiver is set to wake capable or switched off.*
- 3.) Supply undervoltage: as soon as the threshold is crossed again, i.e. VCAN > VCAN_UV.*
- 4.) In all cases (also for TSD shutdown): to enable the Bus transmission again, TXDCANx needs to be HIGH for a certain time (transmitter enable time).*

Serial Peripheral Interface

Bus Communication Status 3

BUS_STAT_3

Bus Communication Status 3 (Address 100 1011_B)

POR / Soft Reset Value: 0000 0000_B; Restart Value: 0000 00xx_B

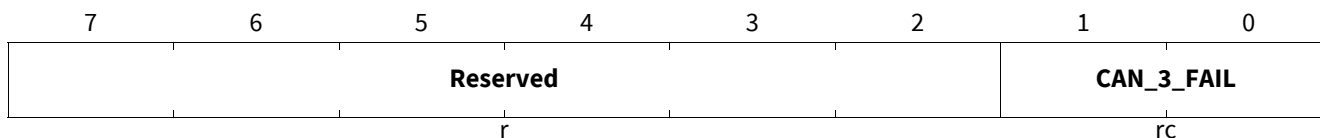

Field	Bits	Type	Description
Reserved	7:2	r	Reserved, always reads as 0
CAN_3_FAIL	1:0	rc	CAN_3 Failure Status 00 _B No error 01 _B CAN TSD shutdown 10 _B CAN_TXD_DOM: TXD dominant time out for more than 2ms 11 _B CAN_BUS_DOM: BUS dominant time out for more than 2ms

Notes

1. CAN Recovery Conditions:
 - 1.) TXD Time Out: TXDCAN3 goes HIGH or transmitter is switched off or the transceiver is wake capable.
 - 2.) Bus dominant time out: Bus will become recessive or transceiver is set to wake capable or switched off.
 - 3.) Supply undervoltage: as soon as the threshold is crossed again, i.e. VCAN > VCAN_UV.
 - 4.) In all cases (also for TSD shutdown): to enable the Bus transmission again, TXDCAN3 needs to be HIGH for a certain time (transmitter enable time).

Serial Peripheral Interface

SMPS state

SMPS_STAT

SMPS state (Address 100 1100_B)

POR / Soft Reset Value: 0000 0000_B; Restart Value: xxx0 0xx0_B

7	6	5	4	3	2	1	0
BST_ACT	BST_SH	BST_OP	Reserved		BCK_SH	BCK_OP	Reserved
rc	rc	rc	r		rc	rc	r

Field	Bits	Type	Description
BST_ACT	7	rc	Boost Regulator Active 0 _B Boost not active 1 _B Boost active
BST_SH	6	rc	BSTD short detection 0 _B No short detected on BSTD pin 1 _B BSTD short to supply
BST_OP	5	rc	BSTD open detection 0 _B No open detected on BSTD pin 1 _B BSTD loss of diode detected or loss of Boost GND
Reserved	4:3	r	Reserved, always reads as 0
BCK_SH	2	rc	BCKSW pin short detection 0 _B No BCKSW short detected 1 _B Short to GND or short to V _S detected on BCKSW pin
BCK_OP	1	rc	BCKSW pin open detection 0 _B No BCKSW open detected 1 _B BCKSW loss of freewheeling or BCKSW loss of GND
Reserved	0	r	Reserved, always reads as 0

Serial Peripheral Interface

ADC state

ADC_STAT

ADC state (Address 101 1000_B)

POR / Soft Reset Value: 0000 0000_B; Restart Value: xxxx xxxx_B

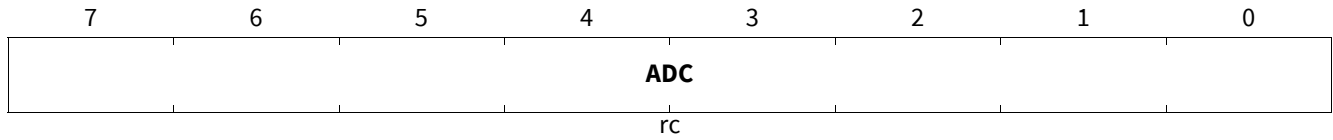

Field	Bits	Type	Description
ADC	7:0	rc	ADC output

Serial Peripheral Interface

13.6.2 Family and Product Information Register

Family and Product Identification Register

FAM_PROD_STAT

Family and Product Identification Register (Address 111 1110_B)

POR / Soft Reset Value: 0100 yyyy_B; Restart Value: 0100 yyyy_B

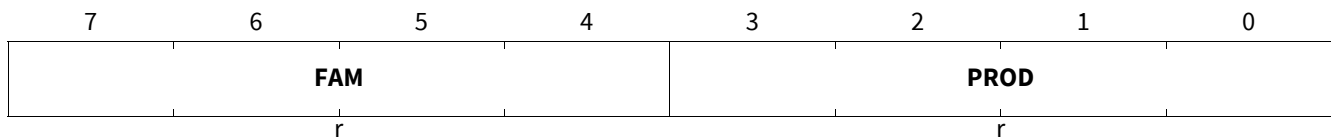

Field	Bits	Type	Description
FAM	7:4	r	SBC Family Identifier (bit4=LSB; bit7=MSB) 0 0 01 _B Driver SBC Family 0 0 10 _B DC/DC-SBC Family 0 0 11 _B Mid-Range SBC Family 0 1 00 _B Multi-CAN Power+ SBC Family 0 1 01 _B LITE SBC Family 0 1 00 _B Mid-Range+ SBC Family
PROD	3:0	r	SBC Product Identifier (bit0=LSB; bit3=MSB) 0 0 0 0 _B TLE9278-3BQX 0 0 0 1 _B TLE9278-3BQX V33 0 0 1 0 _B TLE9278BQX 0 0 1 1 _B TLE9278BQX V33

Notes

- The actual default register value after POR, Soft Reset or Restart of PROD depends on the respective product. Therefore the value 'y' is specified.

Serial Peripheral Interface

13.7 Electrical Characteristics

Table 25 Electrical Characteristics: Power Stage

$V_S = 5.5\text{ V to }28\text{ V}$, $T_j = -40^\circ\text{C to }+150^\circ\text{C}$, all voltages with respect to ground, positive current flowing into pin (unless otherwise specified)

Parameter	Symbol	Values			Unit	Note or Test Condition	Number
		Min.	Typ.	Max.			
SPI frequency							
Maximum SPI frequency	$f_{\text{SPI,max}}$	–	–	4.0	MHz	¹⁾	P_13.7.1
SPI Interface; Logic Inputs SDI, CLK and CSN							
H-input Voltage Threshold	V_{IH}	–	–	$0.7 \times V_{\text{IO}}$	V	–	P_13.7.2
L-input Voltage Threshold	V_{IL}	$0.3 \times V_{\text{IO}}$	–	–	V	–	P_13.7.3
Hysteresis of input Voltage	V_{IHY}	–	$0.2 \times V_{\text{IO}}$	–	V	^{–1)}	P_13.7.4
Pull-up Resistance at pin CSN	R_{ICSN}	20	40	80	k Ω	$V_{\text{CSN}} = 0.7 \times V_{\text{IO}}$	P_13.7.5
Pull-down Resistance at pin SDI and CLK	$R_{\text{ICLK/SDI}}$	20	40	80	k Ω	$V_{\text{SDI/CLK}} = 0.2 \times V_{\text{IO}}$	P_13.7.6
Input Capacitance at pin CSN, SDI or CLK	C_{I}	–	10	–	pF	¹⁾	P_13.7.7
Logic Output SDO							
H-output Voltage Level	V_{SDOH}	$V_{\text{IO}} - 0.4$	$V_{\text{IO}} - 0.2$	–	V	$I_{\text{DOH}} = -1.6\text{ mA}$	P_13.7.8
L-output Voltage Level	V_{SDOL}	–	0.2	0.4	V	$I_{\text{DOL}} = 1.6\text{ mA}$	P_13.7.9
Tri-state Leakage Current	I_{SDOLK}	-10	–	10	μA	$V_{\text{CSN}} = V_{\text{IO}}$; $0\text{ V} < V_{\text{DO}} < V_{\text{IO}}$	P_13.7.10
‘Tri-state Input Capacitance	C_{SDO}	–	10	15	pF	¹⁾	P_13.7.11
Data Input Timing¹⁾							
Clock Period	t_{pCLK}	250	–	–	ns	–	P_13.7.12
Clock HIGH Time	t_{CLKH}	125	–	–	ns	–	P_13.7.13
Clock LOW Time	t_{CLKL}	125	–	–	ns	–	P_13.7.14
Clock LOW before CSN LOW	t_{bef}	125	–	–	ns	–	P_13.7.15
CSN Setup Time	t_{lead}	250	–	–	ns	–	P_13.7.16
CLK Setup Time	t_{lag}	250	–	–	ns	–	P_13.7.17
Clock LOW after CSN HIGH	t_{beh}	125	–	–	ns	–	P_13.7.18
SDI Setup Time	t_{DISU}	100	–	–	ns	–	P_13.7.19
SDI Hold Time	t_{DIHO}	50	–	–	ns	–	P_13.7.20
Input Signal Rise Time at pin SDI, CLK and CSN	t_{rIN}	–	–	50	ns	–	P_13.7.21
Input Signal Fall Time at pin SDI, CLK and CSN	t_{fIN}	–	–	50	ns	–	P_13.7.22

Serial Peripheral Interface

Table 25 Electrical Characteristics: Power Stage

$V_S = 5.5\text{ V to }28\text{ V}$, $T_j = -40^\circ\text{C to }+150^\circ\text{C}$, all voltages with respect to ground, positive current flowing into pin (unless otherwise specified)

Parameter	Symbol	Values			Unit	Note or Test Condition	Number
		Min.	Typ.	Max.			
Delay Time for Mode Changes ²⁾	$t_{\text{Del,Mode}}$	–	–	5	μs	–	P_13.7.23
CSN HIGH Time	$t_{\text{CSN(high)}}$	3	–	–	μs	–	P_13.7.24

Data Output Timing¹⁾

SDO Rise Time	t_{rSDO}	–	30	80	ns	$C_L = 100\text{ pF}$	P_13.7.25
SDO Fall Time	t_{fSDO}	–	30	80	ns	$C_L = 100\text{ pF}$	P_13.7.26
SDO Enable Time	t_{ENSDO}	–	–	50	ns	LOW impedance	P_13.7.27
SDO Disable Time	t_{DISSDO}	–	–	50	ns	HIGH impedance	P_13.7.28
SDO Valid Time	t_{VASDO}	–	–	50	ns	$C_L = 100\text{ pF}$	P_13.7.29

- 1) Not subject to production test; specified by design.
- 2) Applies to all mode changes triggered via SPI commands.

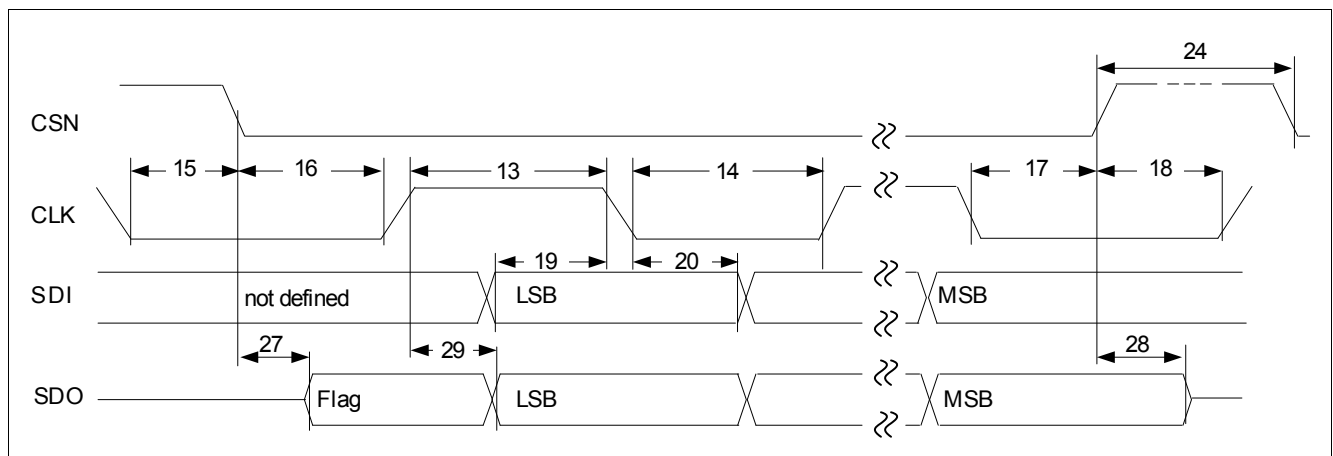

Figure 46 SPI Timing Diagram

Note: Numbers in drawing correlate with the last 2 digits of the Number field in the Electrical Characteristics table.

Application Information

14 Application Information

14.1 Application Diagram

Note: The following information is given as a hint for the implementation of the device only and shall not be regarded as a description or warranty of a certain functionality, condition or quality of the device.

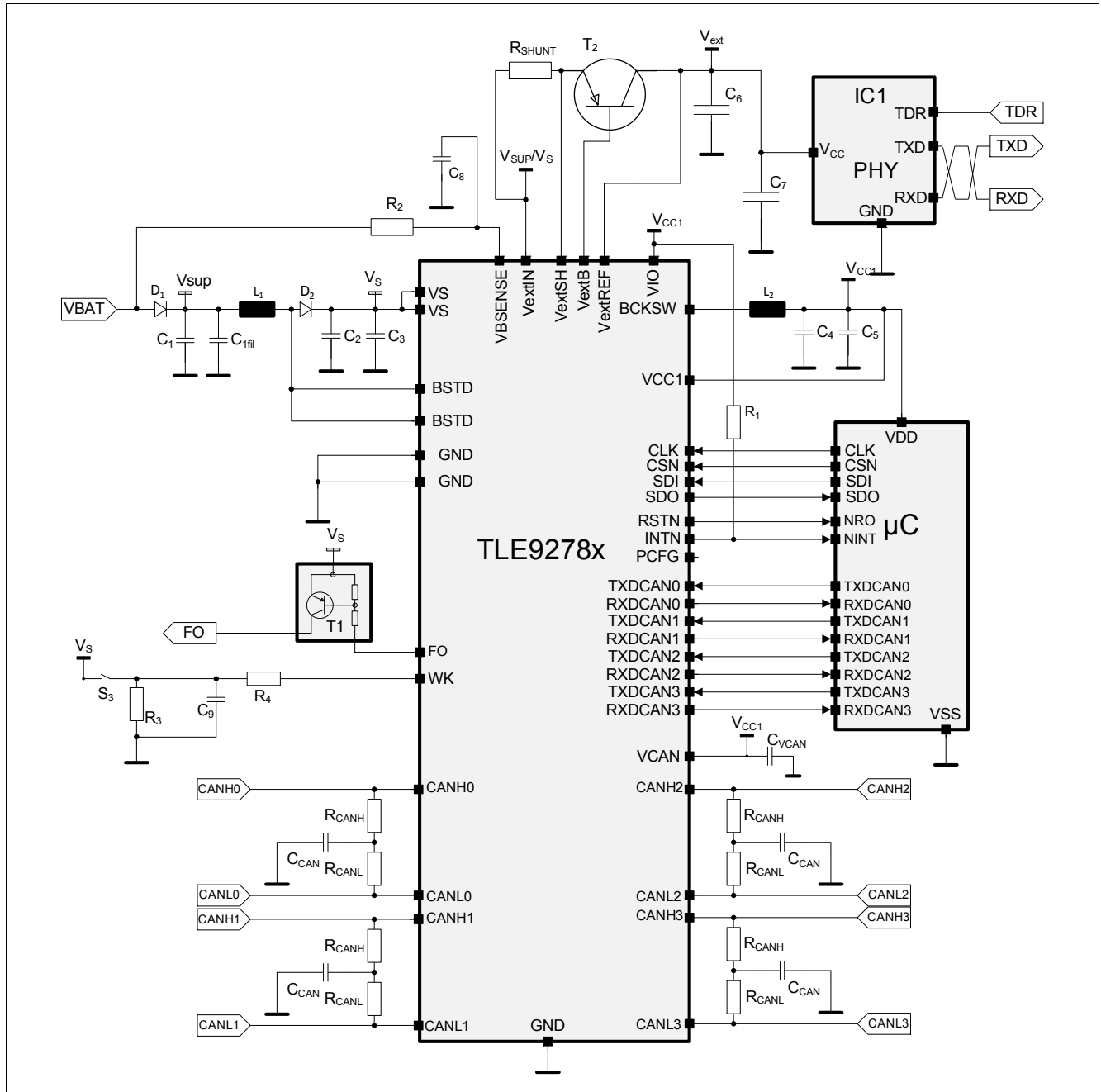

Figure 47 TLE9278BQX V33 Application Diagram

Application Information

Table 26 Bill of Material

Ref.	Typical Value	Purpose / Comment
Capacitances		
C1	47 $\mu\text{F} \pm 20\%$ Electrolytic	Buffering capacitor to cut off battery spikes, depending on the application. The voltage rating depends on the application.
C1fil	100 nF $\pm 20\%$, 50 V ceramic	Input filter battery capacitor for optimum EMC behavior.
C2	100 $\mu\text{F} \pm 20\%$, 50 V, Electrolytic	Output Boost capacitor. ESR $\leq 1\Omega$ over the temperature range.
C3	1..10 $\mu\text{F} \pm 20\%$, 50 V Ceramic	Input Buck capacitor. Low ESR.
C4, C5	22 $\mu\text{F} \pm 20\%$, 16V Ceramic	Output Buck capacitor, for optimum current capability and dynamic behavior. Low ESR.
C ₆	10 $\mu\text{F} \pm 20\%$, 16 V ceramic	¹⁾ V _{EXT} Output capacitor. Low ESR.
C ₇	470 pF $\pm 20\%$, 16 V ceramic	V _{EXT} Filter capacitor (only needed if used for off-board supply).
C ₈	22 nF $\pm 20\%$, 16 V ceramic	V _{BSENSE} blocking capacitor. Low ESR.
C ₉	22 nF $\pm 20\%$, 16 V ceramic	Spikes filtering, as required by application. Mandatory protection for off-board connection.
C _{VCAN}	1 $\mu\text{F} \pm 20\%$, 16 V ceramic	Input filter CAN supply. The capacitor must be placed close to the VCAN pin. For optimum EMC and CAN FD performances, the capacitor has to be $\geq 4.7 \mu\text{F}$
C _{CANx}	47 nF / OEM dependent	Split termination stability.
Resistances		
R _{SHUNT}	1 $\Omega \pm 1\%$	Sense shunt for VEXT current limitation (configured to typ. 235 mA with 1 Ω shunt).
R ₁	10 k Ω ..22 k $\Omega \pm 5\%$	Selection of hardware configuration 1/3, i.e. in case of WD failure SBC Restart Mode is entered. If not connected, then the hardware configuration 2/4 is selected.
R ₂	10 k $\Omega \pm 5\%$	Limit the VBSENSE pin input current.
R3	10 k $\Omega \pm 5\%$	Wetting current of the switch, as required by application.
R4	10 k $\Omega \pm 5\%$	Limit the WK pin input current, e.g. for ISO pulses.
R _{CANHx}	60 Ω / OEM dependent	CAN bus termination.
R _{CANL}	60 Ω / OEM dependent	CAN bus termination.
Inductors		
L ₁	22 μH ..47 $\mu\text{H} \pm 20\%$	²⁾ Boost regulator coil. The saturation current depends on the application.
L ₂	47 $\mu\text{H} \pm 20\%$	²⁾ Buck regulator coil. The saturation current depends on the application.

Active Components

Application Information

Table 26 Bill of Material (cont'd)

Ref.	Typical Value	Purpose / Comment
D1	e.g. SS34HE3/9AT (Vishay) or similar	Reverse polarity protection.
D2	e.g. SL04-GS08 (Vishay) or SS34HE3/9AT	Boost regulator power diode. Forward current depends on the application.
T ₂	BCP 52-16, Infineon	Power element of VEXT, current limit to be configured via shunt R _{SHUNT} .
	MJD253, ON Semi	Alternative power element of VEXT.
μC	e.g. XC2xxx	Microcontroller.

- 1) For optimized EMC performance, one additional filter capacitor $\leq 10 \text{ nF} \pm 20\%$ 16 V ceramic is required.
- 2) The saturation current must be define according to the maximum current capability by the application.

Application Information

14.2 ESD Tests

Tests for ESD robustness according to IEC61000-4-2 “GUN test” (150 pF, 330 Ω) have been performed. The results and test condition are available in a test report. The values for the tests are listed below.

Table 27 ESD “GUN Test”¹⁾²⁾

Performed Test	Result	Unit	Remarks
ESD at pin VS, VBSENSE, VEXTIN, VEXTREF, WK, CANHx, CANLx versus GND	> 6	kV	positive pulse
ESD at pin VS, VBSENSE, VEXTIN, VEXTREF, WK, CANHx, CANLx versus GND	< -6	kV	negative pulse

1) ESD susceptibility “ESD GUN” according to EMC 1.3 Test Specification, Section 4.3 (IEC 61000-4-2). Tested by external test house (IBEE Zwickau, EMC Test report No. 09-12-18).

2) ESD Test “GUN Test” is specified with external components for pins VS, VBSENSE, VEXTIN, VEXTREF and WK. See the application diagrams in [Chapter 14.1](#) for more information.

EMC and ESD susceptibility tests according to SAE J2962-2 (V. 2014-01-23) have been performed. Tested by external test house (Jakob Mooser GmbH, Test report No. 434/2016).

Application Information

14.3 Thermal Behavior of Package

The figure below shows the thermal resistance (R_{th_JA}) of the device vs. the cooling area on the bottom of the PCB for $T_a = 85^\circ\text{C}$. Every line reflects a different PCB and thermal via design.

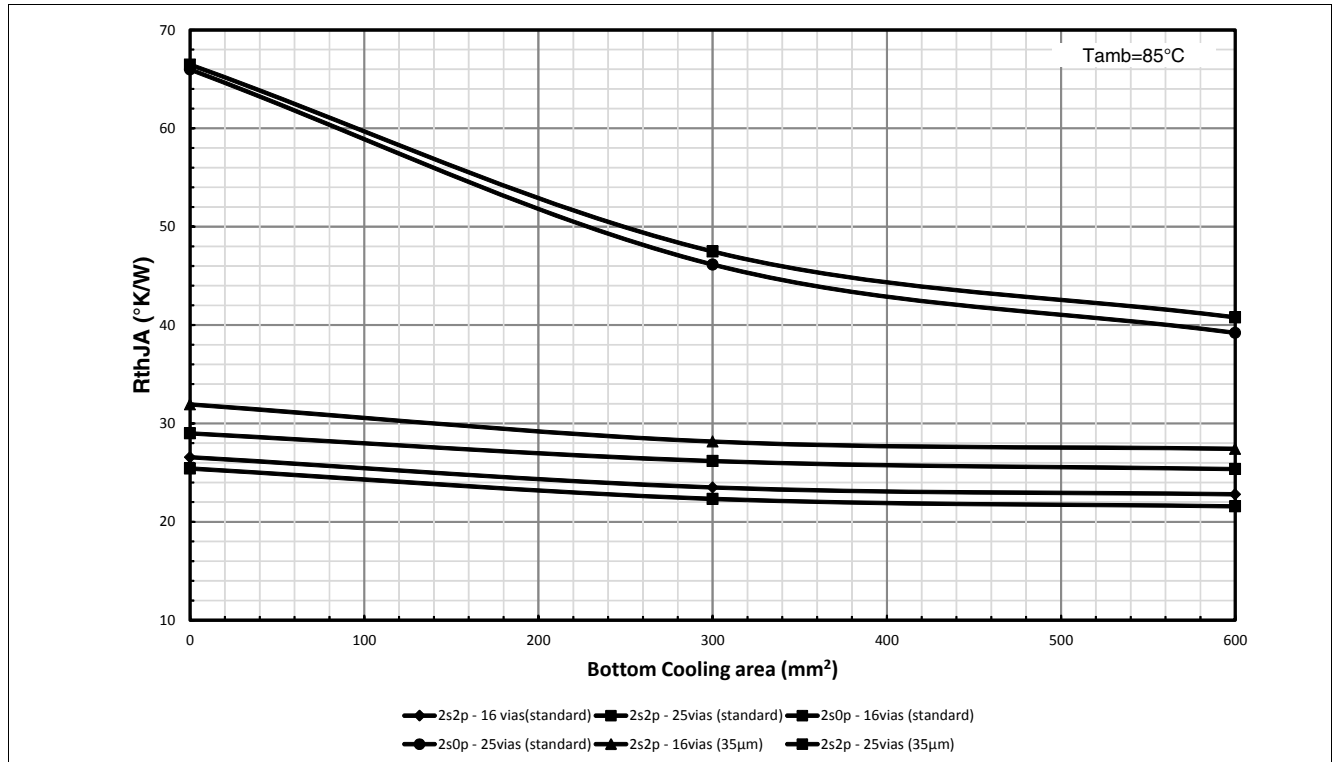

Figure 48 Thermal Resistance (R_{th_JA}) vs. Cooling Area

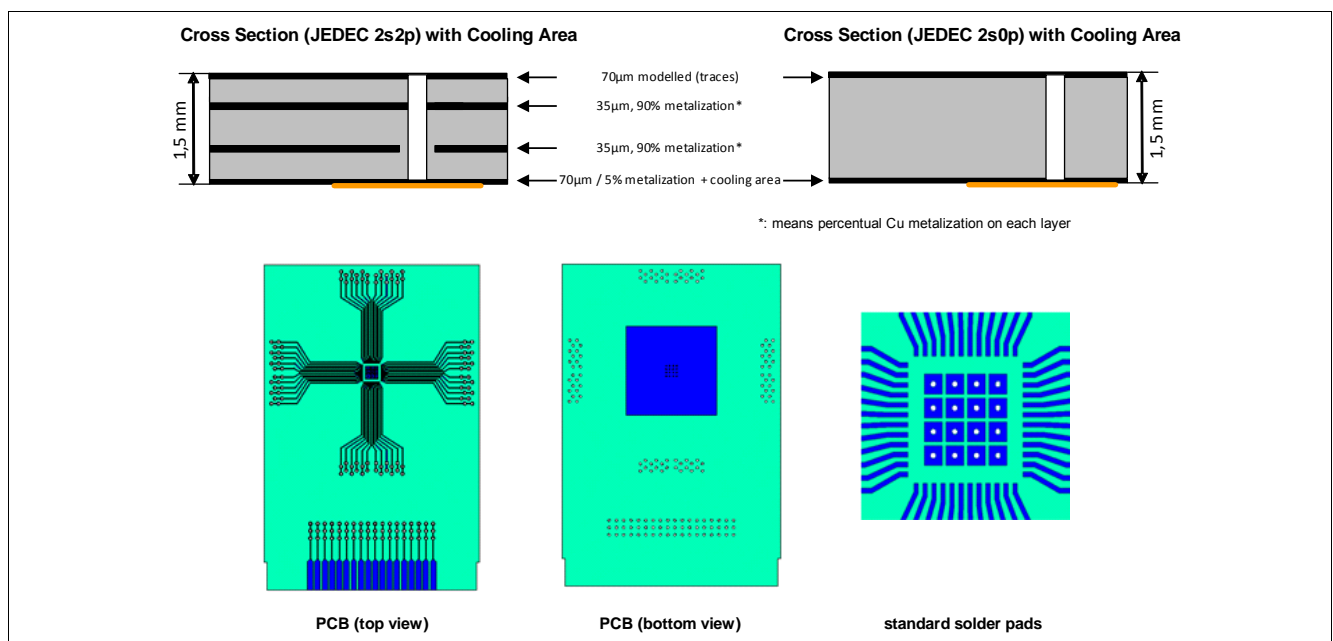

Figure 49 Board Setup

The Board setup is defined according to JESD 51-2,-5,-7.

Board: $76.2 \times 114.3 \times 1.5 \text{ mm}^3$ with 2 inner copper layers (35 μm thick), with thermal via array under the exposed pad contacting the first inner copper layer and the cooling area on the bottom layer (70 μm).

Package Outlines

15 Package Outlines

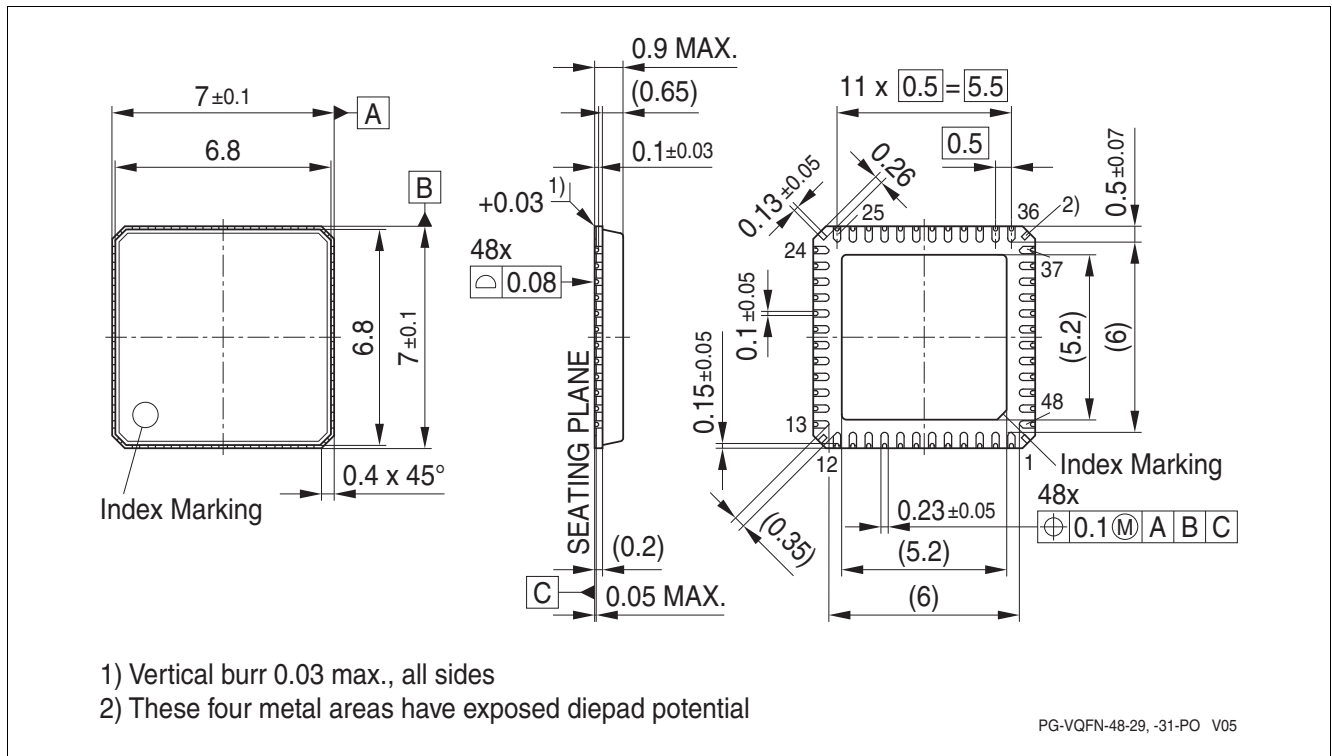

Figure 50 PG-VQFN-48¹⁾

Green Product (RoHS compliant)

To meet the world-wide customer requirements for environmentally friendly products and to be compliant with government regulations the device is available as a green product. Green products are RoHS-Compliant (i.e Pb-free finish on leads and suitable for Pb-free soldering according to IPC/JEDEC J-STD-020).

Further information on packages

<https://www.infineon.com/packages>

1) Dimensions in mm

Revision History

16 Revision History

Revision	Date	Changes
1.4	2019-01-23	Initial Release.

Trademarks

All referenced product or service names and trademarks are the property of their respective owners.

Edition 2019-01-23

Published by

Infineon Technologies AG

81726 Munich, Germany

© 2019 Infineon Technologies AG.

All Rights Reserved.

Do you have a question about any aspect of this document?

Email: erratum@infineon.com

Document reference

IMPORTANT NOTICE

The information given in this document shall in no event be regarded as a guarantee of conditions or characteristics ("Beschaffenhheitsgarantie").

With respect to any examples, hints or any typical values stated herein and/or any information regarding the application of the product, Infineon Technologies hereby disclaims any and all warranties and liabilities of any kind, including without limitation warranties of non-infringement of intellectual property rights of any third party.

In addition, any information given in this document is subject to customer's compliance with its obligations stated in this document and any applicable legal requirements, norms and standards concerning customer's products and any use of the product of Infineon Technologies in customer's applications.

The data contained in this document is exclusively intended for technically trained staff. It is the responsibility of customer's technical departments to evaluate the suitability of the product for the intended application and the completeness of the product information given in this document with respect to such application.

For further information on technology, delivery terms and conditions and prices, please contact the nearest Infineon Technologies Office (www.infineon.com).

WARNINGS

Due to technical requirements products may contain dangerous substances. For information on the types in question please contact your nearest Infineon Technologies office.

Except as otherwise explicitly approved by Infineon Technologies in a written document signed by authorized representatives of Infineon Technologies, Infineon Technologies' products may not be used in any applications where a failure of the product or any consequences of the use thereof can reasonably be expected to result in personal injury.

Компания «Океан Электроники» предлагает заключение долгосрочных отношений при поставках импортных электронных компонентов на взаимовыгодных условиях!

Наши преимущества:

- Поставка оригинальных импортных электронных компонентов напрямую с производств Америки, Европы и Азии, а так же с крупнейших складов мира;
- Широкая линейка поставок активных и пассивных импортных электронных компонентов (более 30 млн. наименований);
- Поставка сложных, дефицитных, либо снятых с производства позиций;
- Оперативные сроки поставки под заказ (от 5 рабочих дней);
- Экспресс доставка в любую точку России;
- Помощь Конструкторского Отдела и консультации квалифицированных инженеров;
- Техническая поддержка проекта, помощь в подборе аналогов, поставка прототипов;
- Поставка электронных компонентов под контролем ВП;
- Система менеджмента качества сертифицирована по Международному стандарту ISO 9001;
- При необходимости вся продукция военного и аэрокосмического назначения проходит испытания и сертификацию в лаборатории (по согласованию с заказчиком);
- Поставка специализированных компонентов военного и аэрокосмического уровня качества (Xilinx, Altera, Analog Devices, Intersil, Interpoint, Microsemi, Actel, Aeroflex, Peregrine, VPT, Syfer, Eurofarad, Texas Instruments, MS Kennedy, Miteq, Cobham, E2V, MA-COM, Hittite, Mini-Circuits, General Dynamics и др.);

Компания «Океан Электроники» является официальным дистрибьютором и эксклюзивным представителем в России одного из крупнейших производителей разъемов военного и аэрокосмического назначения «JONHON», а так же официальным дистрибьютором и эксклюзивным представителем в России производителя высокотехнологичных и надежных решений для передачи СВЧ сигналов «FORSTAR».



JONHON

«JONHON» (основан в 1970 г.)

Разъемы специального, военного и аэрокосмического назначения:

(Применяются в военной, авиационной, аэрокосмической, морской, железнодорожной, горно- и нефтедобывающей отраслях промышленности)

«FORSTAR» (основан в 1998 г.)

ВЧ соединители, коаксиальные кабели, кабельные сборки и микроволновые компоненты:

(Применяются в телекоммуникациях гражданского и специального назначения, в средствах связи, РЛС, а так же военной, авиационной и аэрокосмической отраслях промышленности).



Телефон: 8 (812) 309-75-97 (многоканальный)

Факс: 8 (812) 320-03-32

Электронная почта: ocean@oceanchips.ru

Web: <http://oceanchips.ru/>

Адрес: 198099, г. Санкт-Петербург, ул. Калинина, д. 2, корп. 4, лит. А