

REVISIONS					
P.	LTN.	DESCRIPTION	DATE	DWN.	APVD.
F32		REVISED PER ECO-16-003418	08MAR2016	DLD	DCM
F33		REVISED PER ECO-16-018427	25JAN2017	DLD	DCM
F34		REVISED PER ECO-17-007768	30MAY2017	DLD	DCM
F35		REVISED PER ECO-17-014872	24OCT2017	JMS	CM

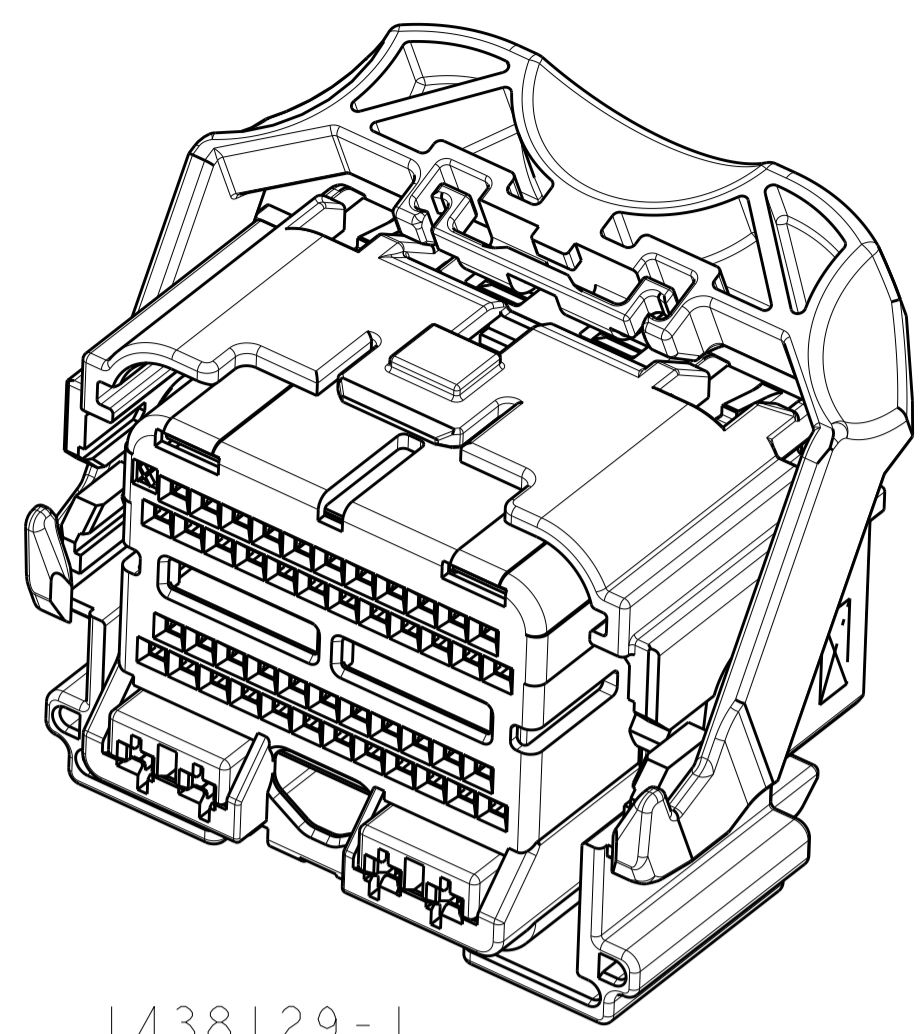

1438129-1  
SHOWN WITH SPACER  
IN SEATED POSITION

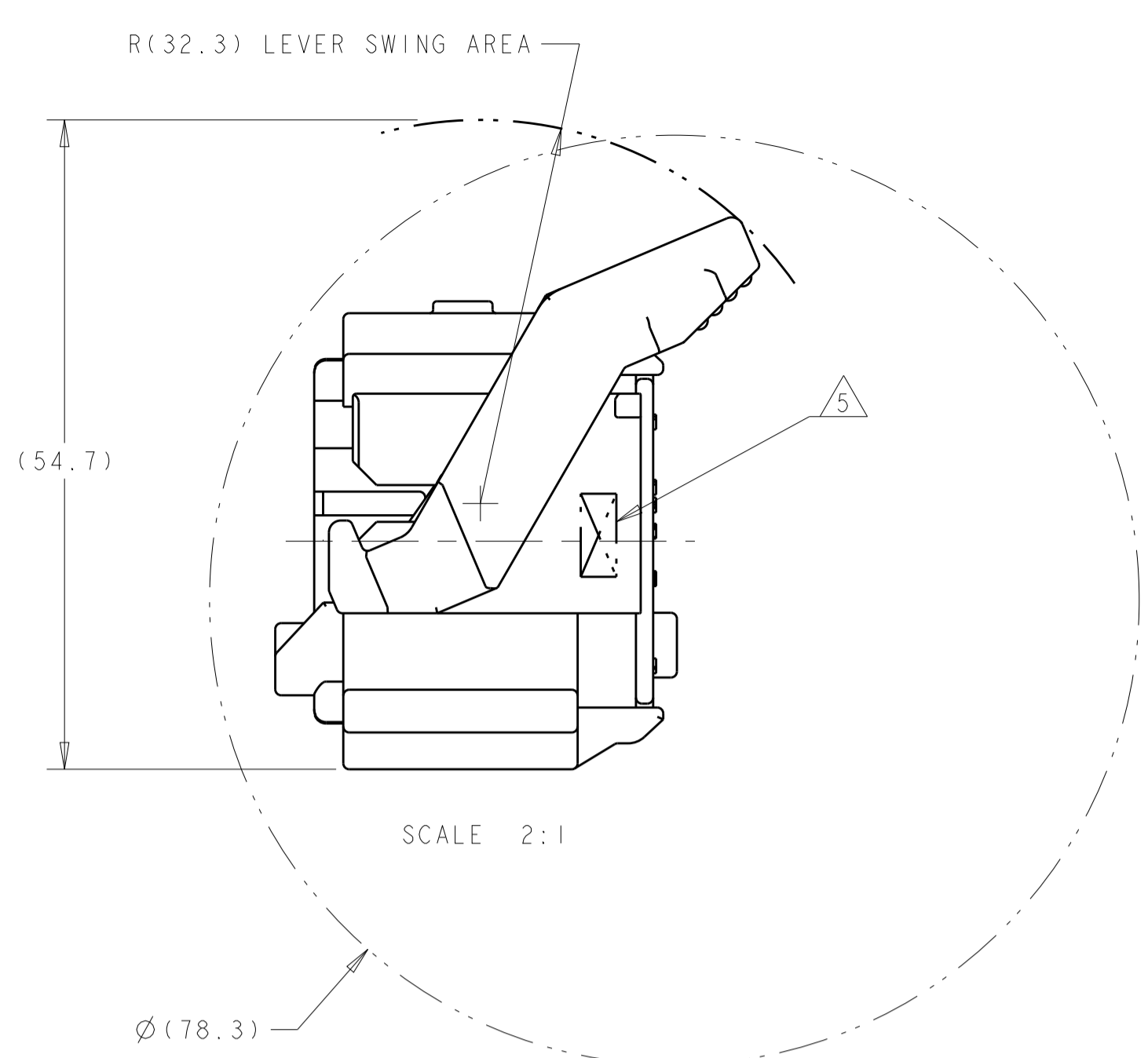
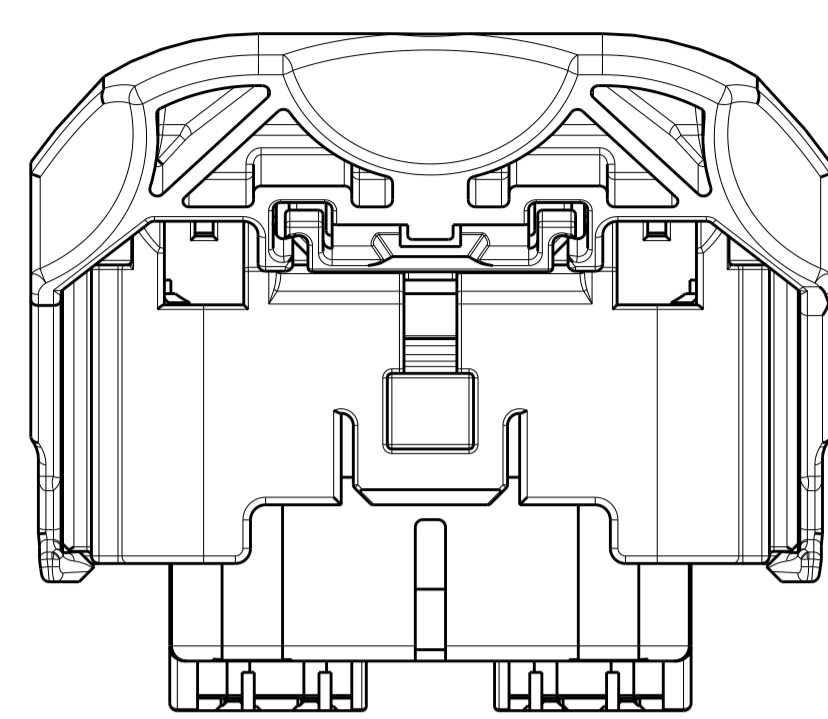

SCALE 2:1

MIN. FEED THRU  
CONDITION WITH 1mm  
CLEARANCE ALL AROUND  
SHOWN WITH SPACER IN SEATED POSITION

1. PRINT PART NUMBER (5S4T-14A464-L\*-\*\*\*, 5S4T-14A464-M\*-\*\*\*, 5S4T-14A464-N\*-\*\*\*) AND TRACEABILITY (YY : 2 DIGIT YEAR, JJJ = JULIAN DATE, HH = 2 DIGIT MILITARY HOUR CODE IN THE LOCATION AT ASSEMBLY. SEE SHEET 3 THRU 7 (-\*) PART NUMBERS.
  2. APPLICABLE MOLEX (1.5) POWER TERMINAL PART NUMBERS:  
33012-0002 TIN 0.50-1.50mm<sup>2</sup>
  3. CAM LEVER AND SPACER ARE SHIPPED IN THEIR PRE-ASSEMBLED POSITIONS.
  4. REFERENCE TO CONNECTIVITY INSTRUCTION SHEET 408-8893.
- △ COMPANY LOGO.

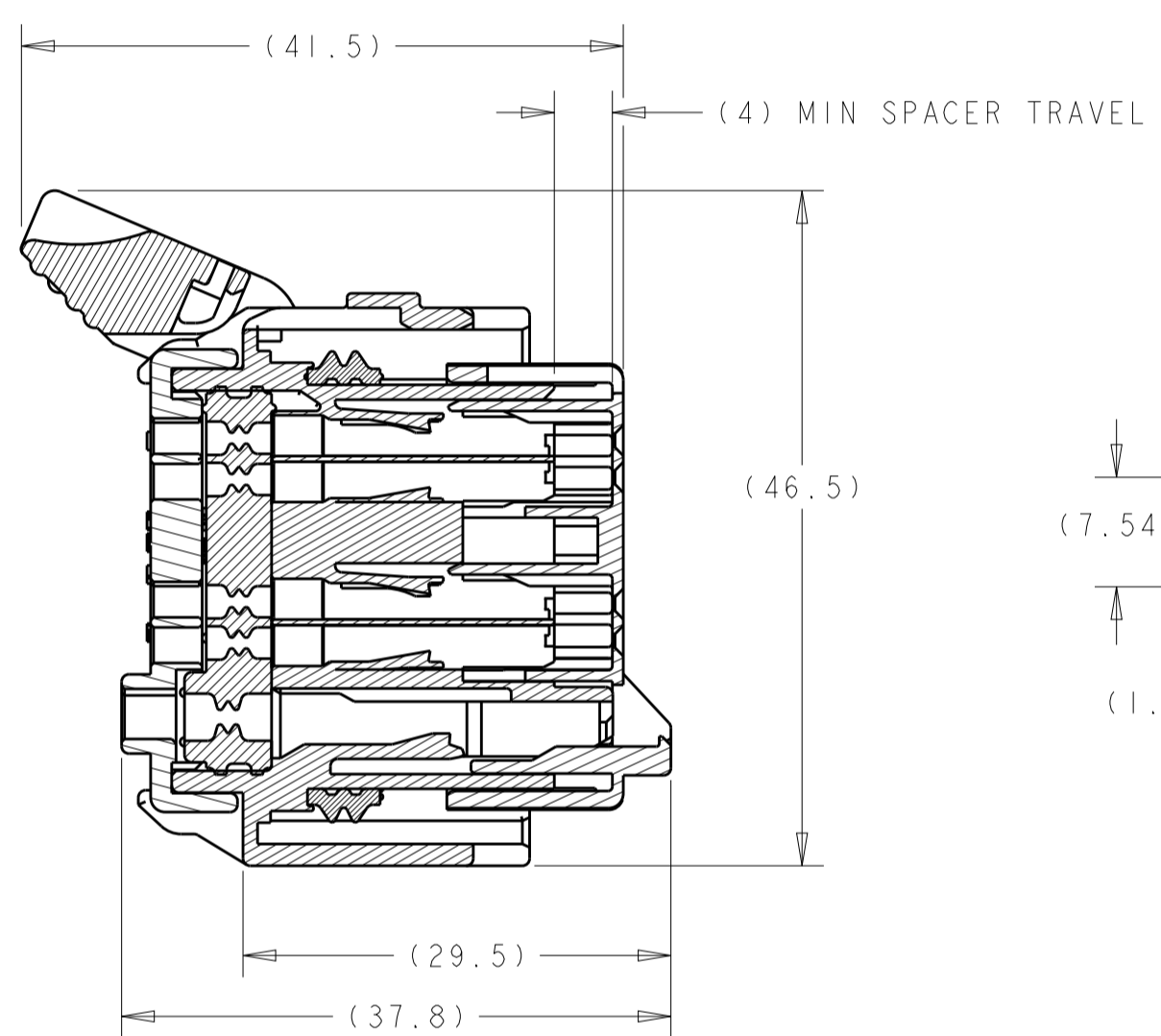

SECTION A-A  
SPACER AND LEVER IN  
PRE-SEATED POSITION  
(DELIVERY CONDITION)

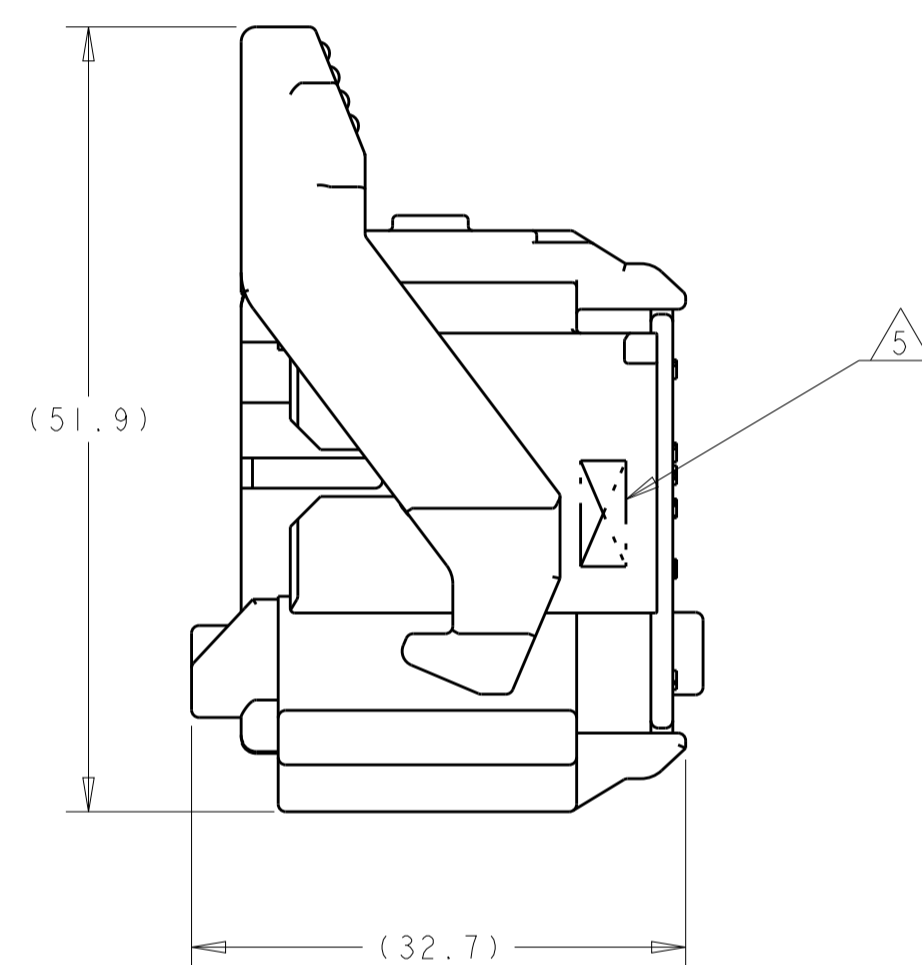
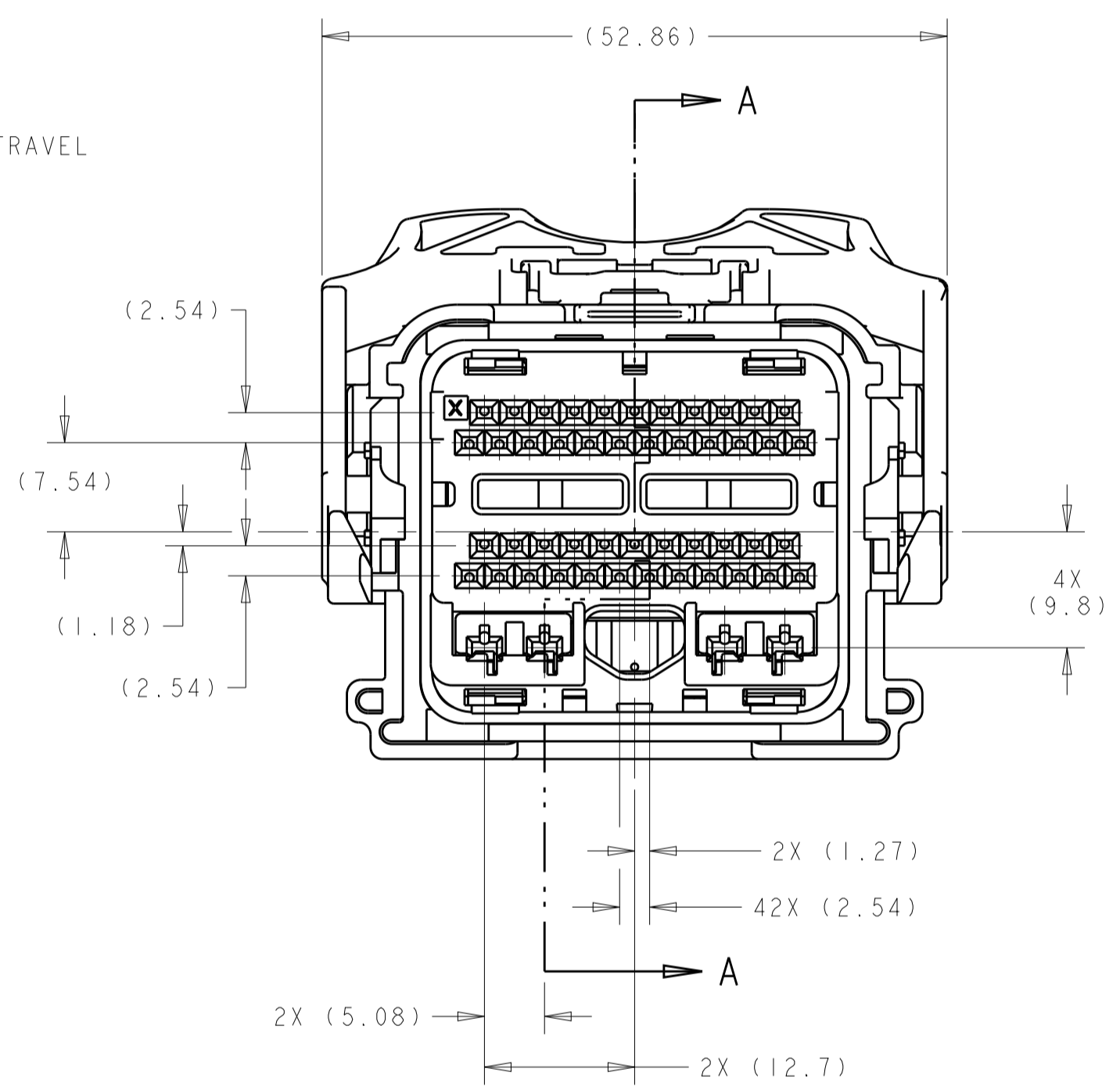

SHOWN WITH CAM  
LEVER AND SPACER  
IN LOADED POSITION

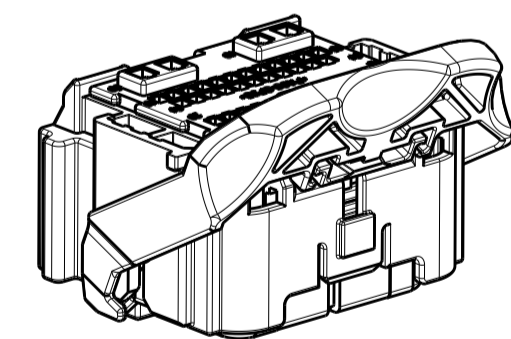
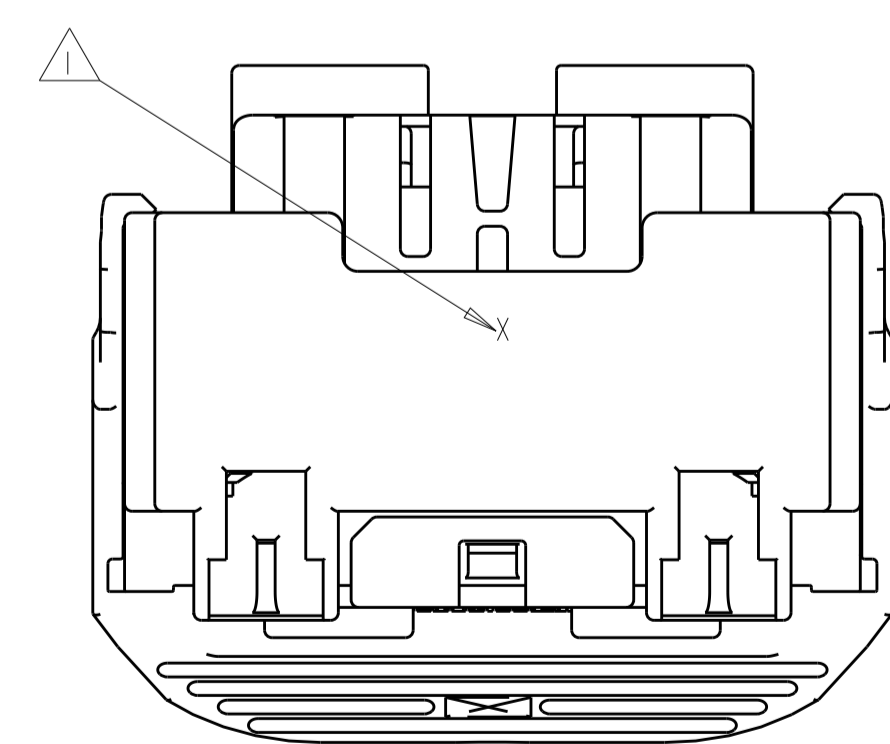

SCALE 1:1

APPLICABLE COMPONENTS (FOR REFERENCE ONLY)						
DESCRIPTION	NOMINAL TERMINAL SIZE	COLOR/PLATING	FORD COMPONENT PART NUMBER	SUPPLIER PART NUMBER	MATERIAL/SPECIFICATION NUMBER	SAE WIRE SIZE
TERMINAL - FEMALE (Ag)	0.64 (CAT. 0)	SILVER	7S4T-14474-AA	I393366-2	COPPER ALLOY/SILVER PLATE	20AWG
TERMINAL - FEMALE (Ag)	0.64 (CAT. 0)	SILVER	7S4T-14474-BA	I393367-2	COPPER ALLOY/SILVER PLATE	18AWG
TERMINAL - FEMALE (Sn)	0.64 (CAT. 0)	TIN	1L2T-14474-AA	I393366-1	COPPER ALLOY/TIN PLATE	20AWG
TERMINAL - FEMALE (Sn)	0.64 (CAT. 0)	TIN	1L2T-14474-BA	I393367-1	COPPER ALLOY/TIN PLATE	22AWG
TERMINAL - FEMALE (Au)	0.64 (CAT. 0)	GOLD	1L2T-14474-CA	I393365-1	COPPER ALLOY/GOLD PLATE	20AWG
TERMINAL - FEMALE (Au)	0.64 (CAT. 0)	GOLD	1L2T-14474-DA	I393364-1	COPPER ALLOY/GOLD PLATE	18AWG
TERMINAL - FEMALE (Au)	0.64 (CAT. 0)	GOLD	1L2T-14474-DA	I393364-1	COPPER ALLOY/GOLD PLATE	22AWG

ANY DESIGN CHANGES ON THIS ASSEMBLY MAY ALSO BE REQUIRED ON ASSEMBLY DRAWING 1438691

SEE TABLES  
SHEETS 3 THRU 7  
PART NUMBER

THIS DRAWING IS A CONTROLLED DOCUMENT.		DWN: R. VESTAL 15APR2005	
DIMENSIONS: mm		CHK: T. VALASEK 15APR2005	
TOLERANCES UNLESS OTHERWISE SPECIFIED:		APVD: T. VALASEK 15APR2005	NAME: 50-WAY HARNESS ASSEMBLY, PCM
0 PLC ±0.3 1 PLC ±0.10 2 PLC ±0.10 3 PLC ±0.10 4 PLC ±0.10 ANGLES ±1°		PRODUCT SPEC: -	SIZE: A100779
MATERIAL: -		APPLICATION SPEC: -	CAGE CODE: -
FINISH: -		WEIGHT: -	DRAWING NO: 1438129
CUSTOMER DRAWING		SCALE: 1:1	SHEET 1 OF 10

REVISIONS				
P.	LTH	DESCRIPTION	DATE	APPV
-	-	SEE SHEET 1	-	-

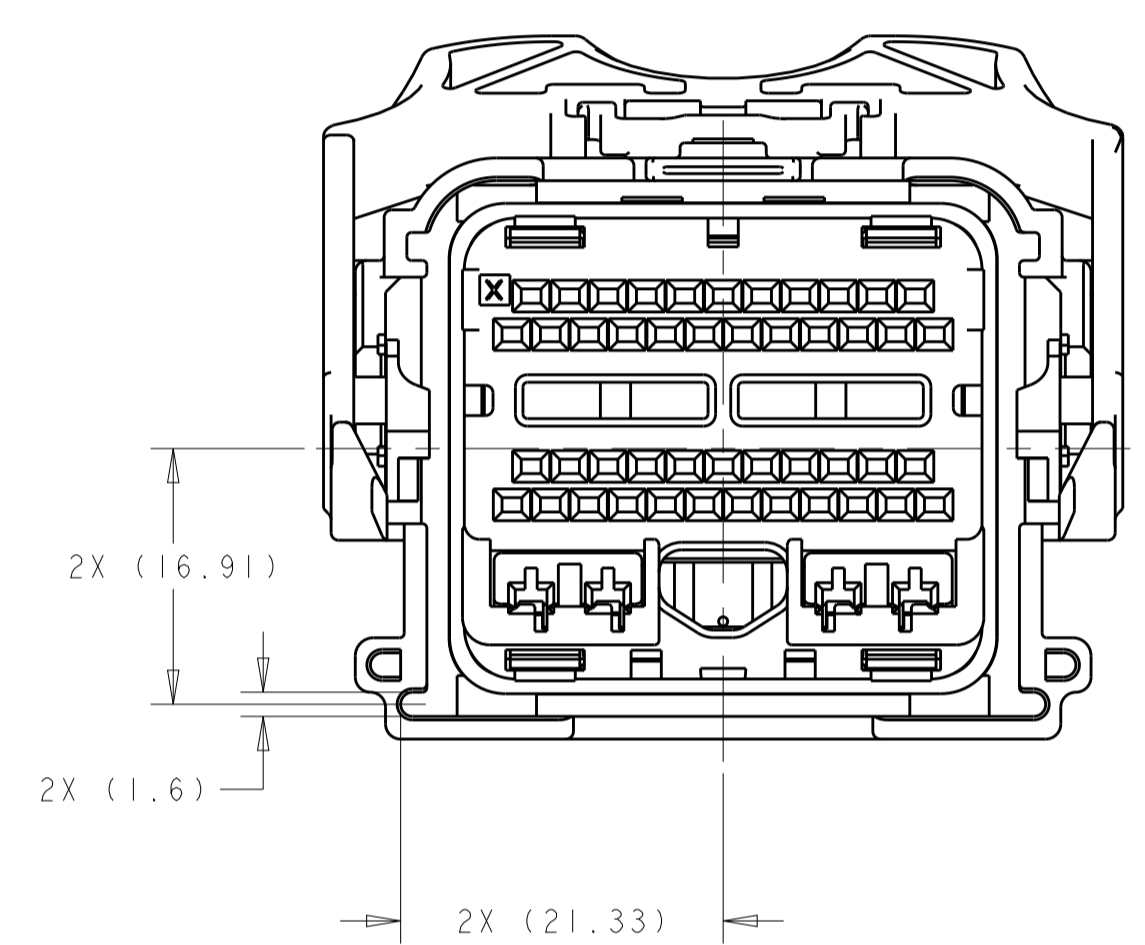
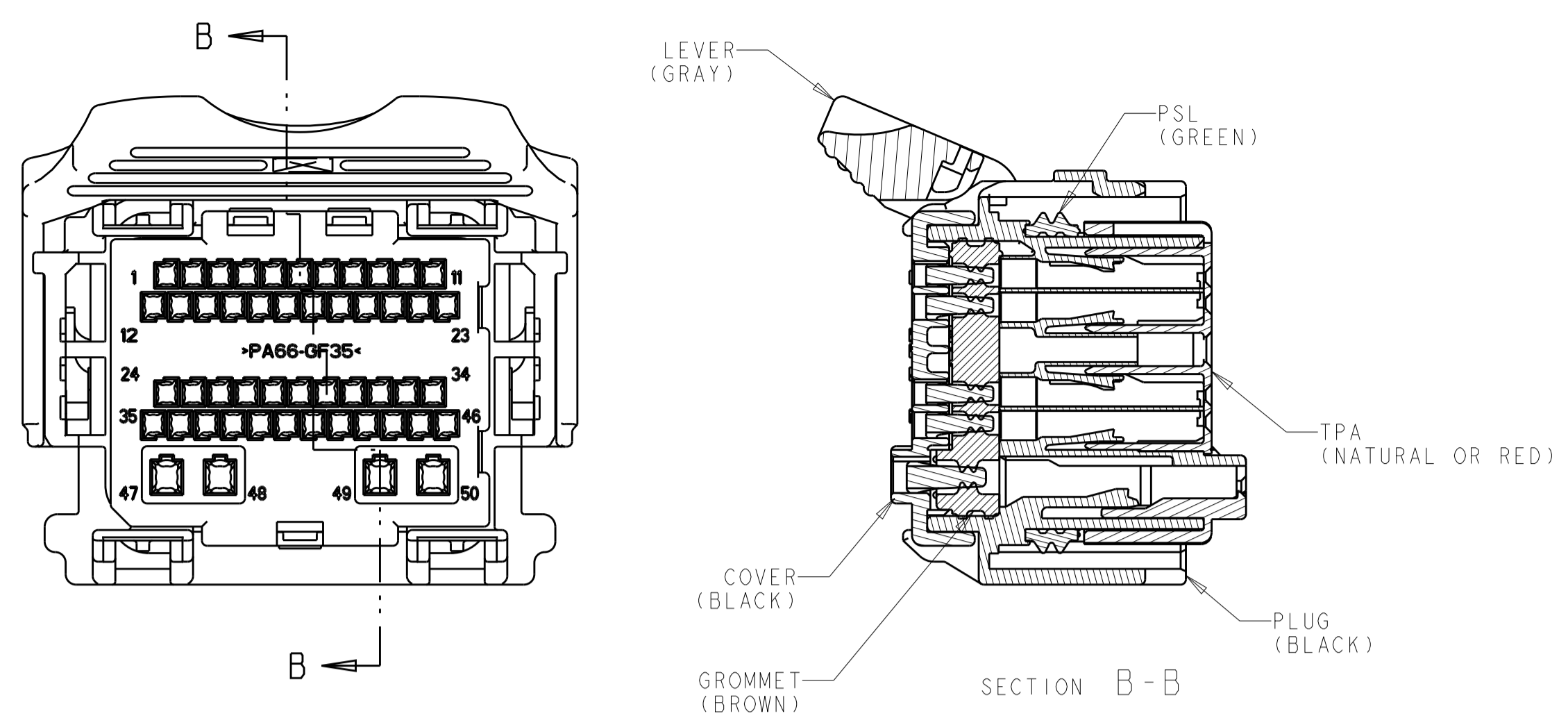

1438129-1  
KEYING OPTION "A"

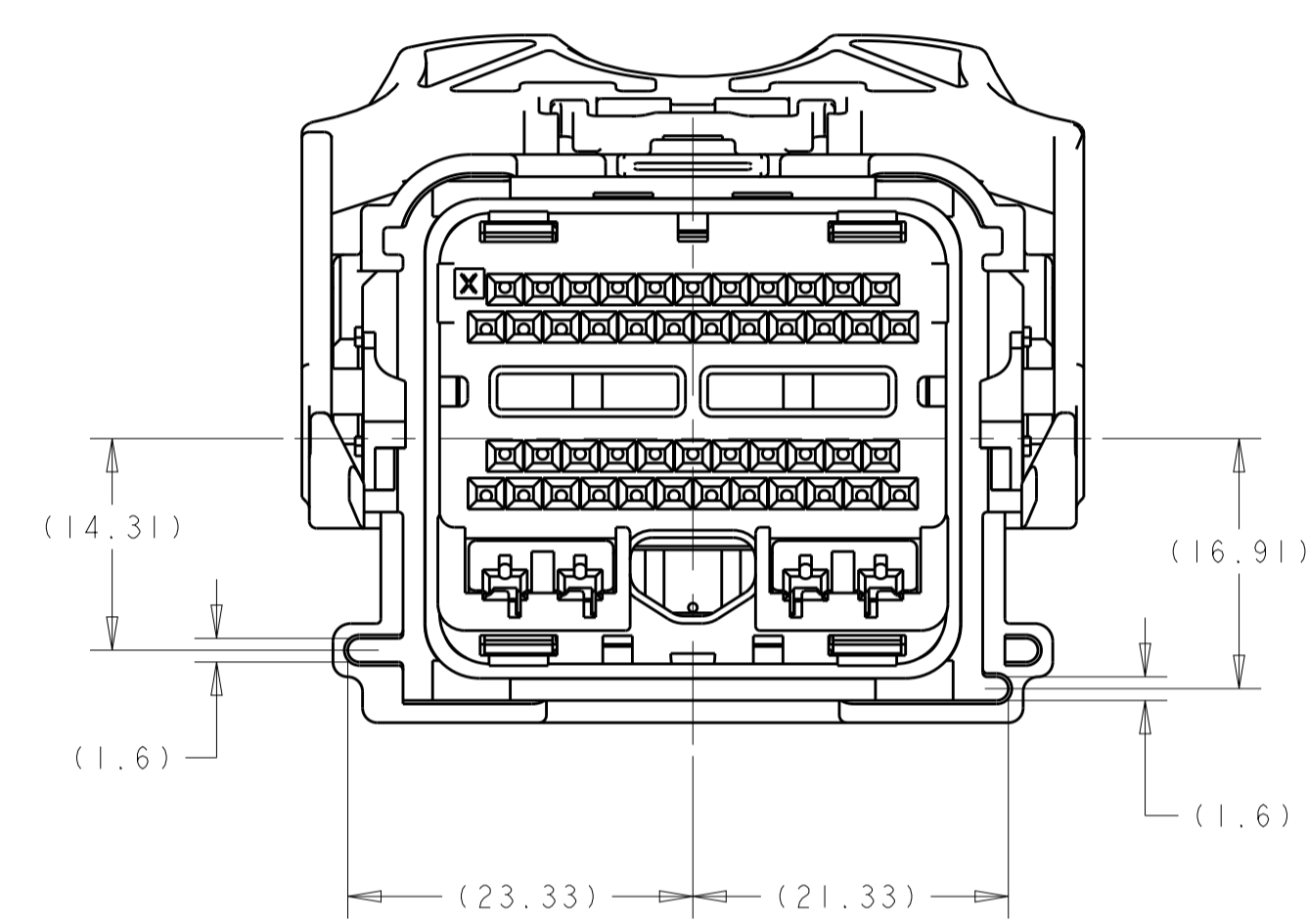

1438129-2  
KEYING OPTION "B"

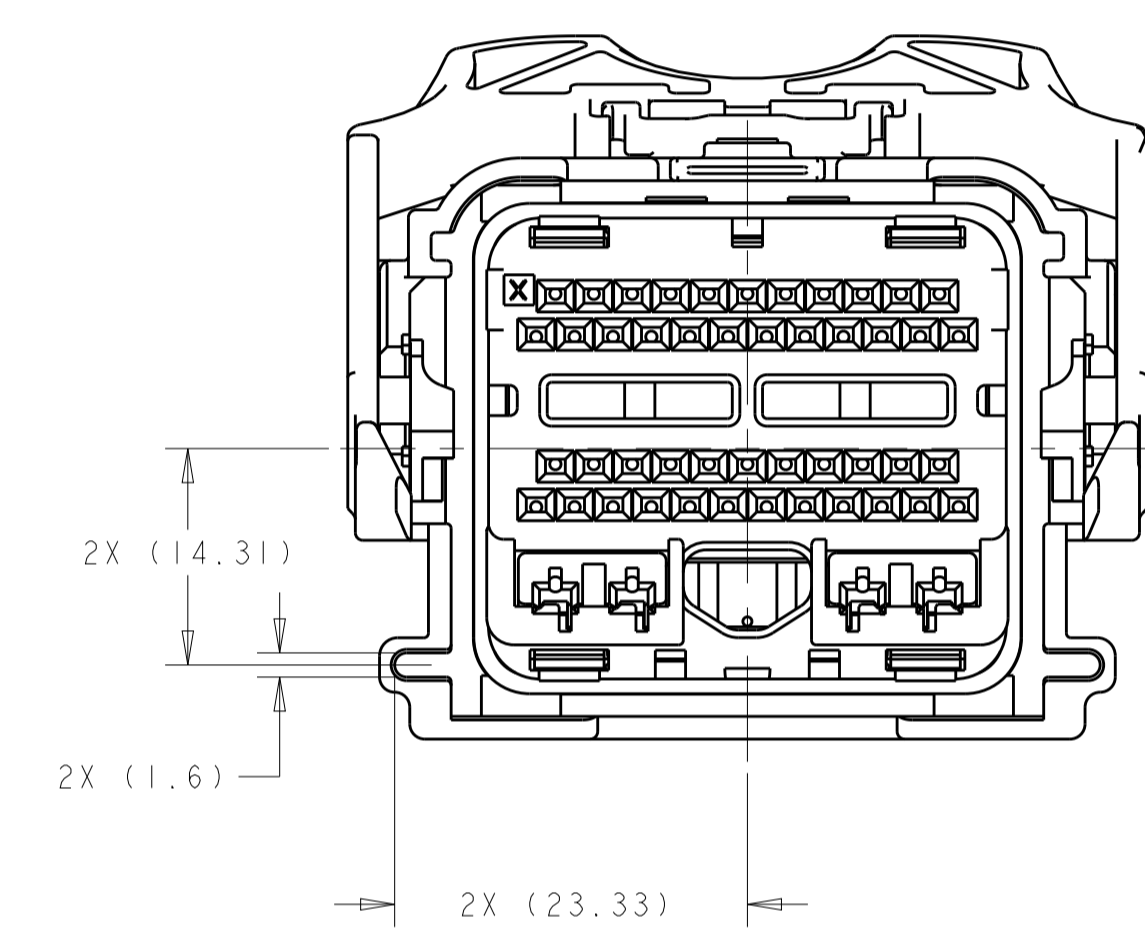

1438129-3  
KEYING OPTION "C"

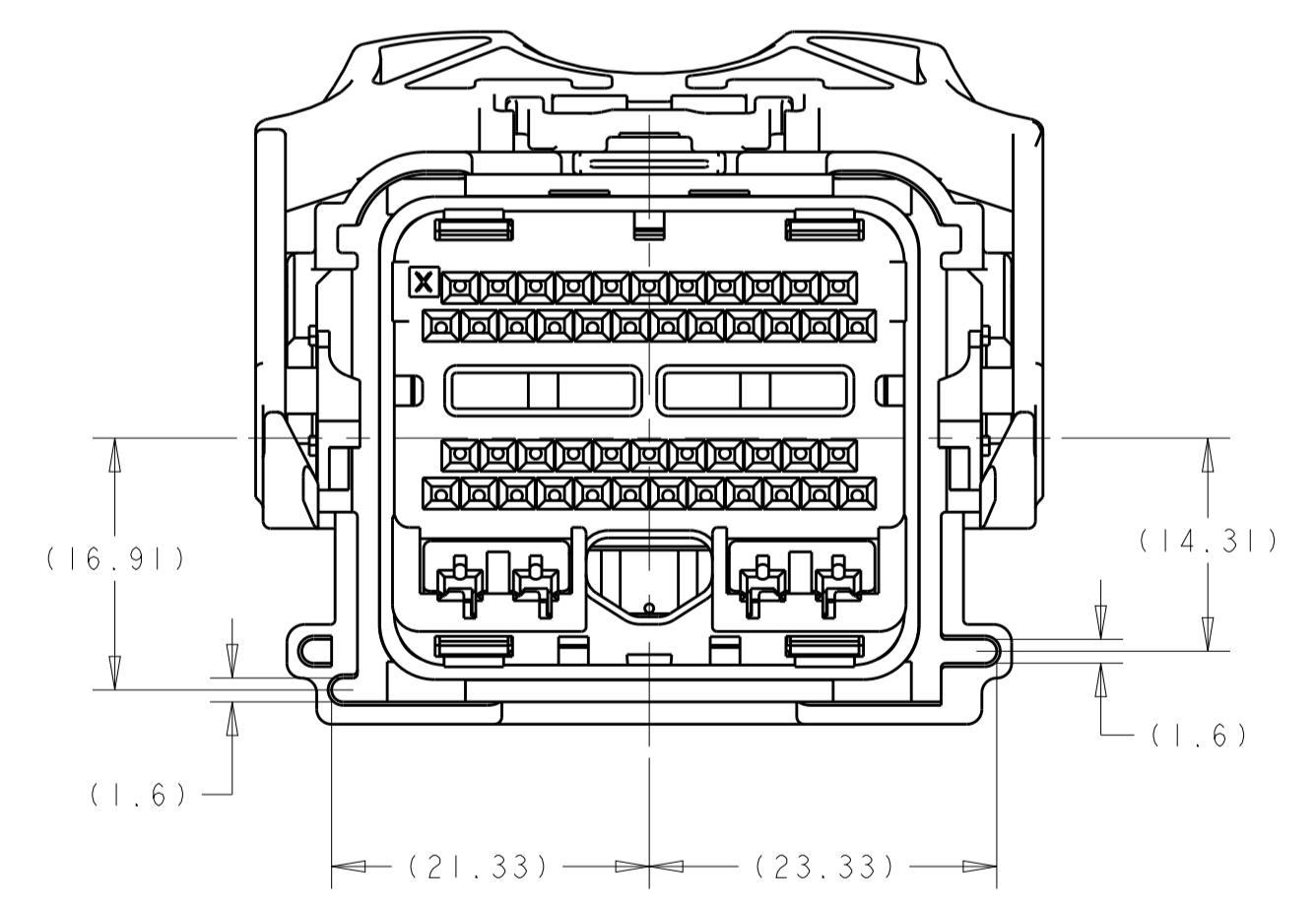

1438129-4  
KEYING OPTION "D"

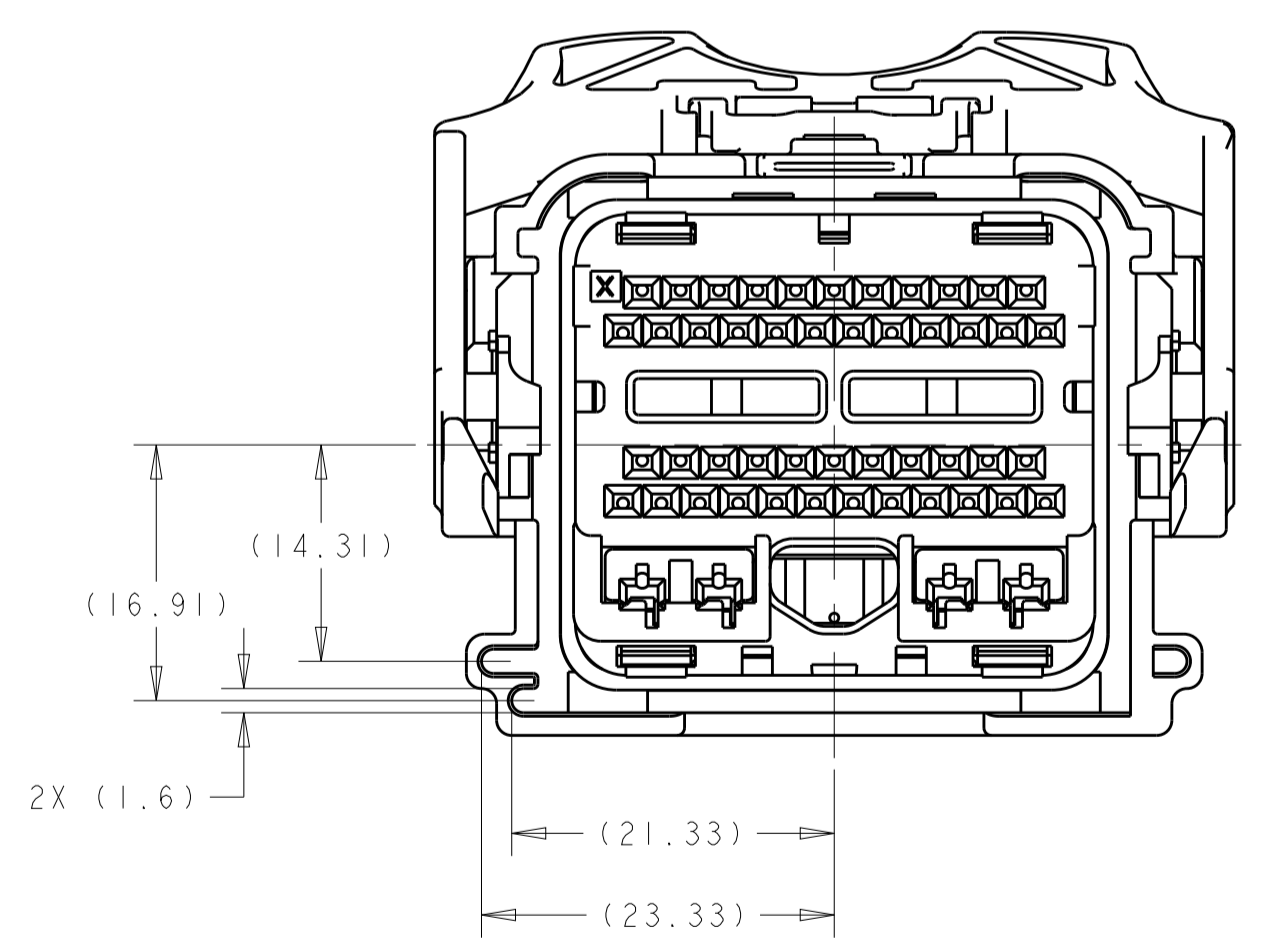

1438129-5  
KEYING OPTION "E"

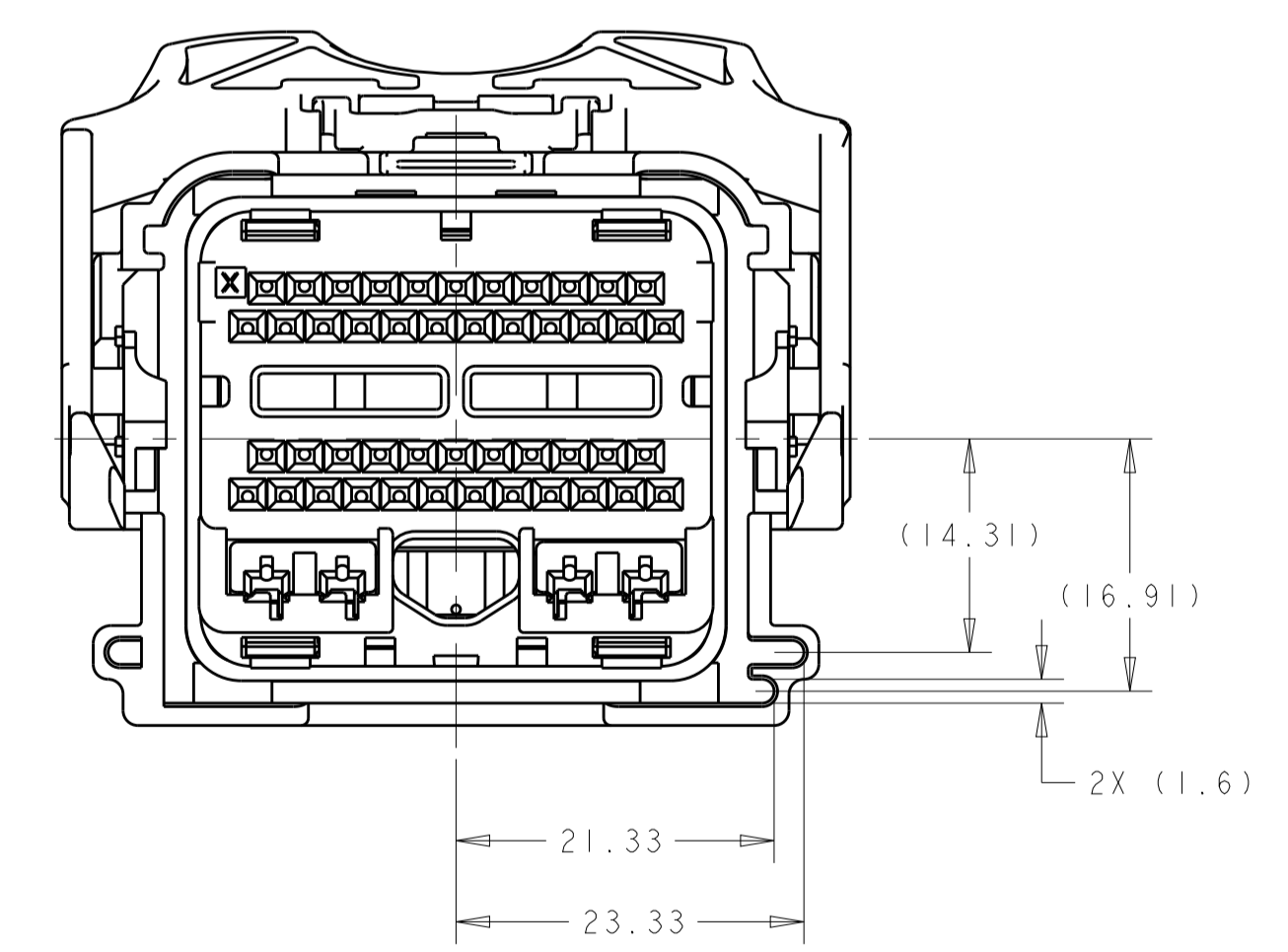

1438129-6  
KEYING OPTION "F"

THIS DRAWING IS A CONTROLLED DOCUMENT.		OWN: R. VESTAL 15APR2005	TE Connectivity
DIMENSIONS: mm		CHK: T. VALASEK 15APR2005	
TOLERANCES UNLESS OTHERWISE SPECIFIED:		APVD: T. VALASEK 15APR2005	NAME: 50-WAY HARNESS ASSEMBLY, PCM
0 PLC ±	1 PLC ±0.3	PRODUCT SPEC	SIZE: CAGE CODE: DRAWING NO: A100779C=1438129
2 PLC ±0.10	3 PLC ±	APPLICATION SPEC	RESTRICTED TO
4 PLC ±	ANGLES ±	WEIGHT	SCALE: 2:1 SHEET 2 OF 10 REV: F35
MATERIAL	FINISH	CUSTOMER DRAWING	

REVISIONS table with columns: P, LTR, DESCRIPTION, DATE, DWN, APVD

Main pin-out chart table with columns for terminal positions (50-1) and part numbers (e.g., 3-1924783-9, 554T-14A464-LA-999)

KEYING OPTION A

CAVITIES WITH A NUMERIC SYMBOL INDICATES CLOSED TERMINAL LOCATIONS
BLANK CAVITIES INDICATES OPEN TERMINAL HOLE LOCATIONS
TERMINAL HOLE POSITION

554T-14A464-L\* PIN-OUT CHART

Technical drawing footer containing dimensions, tolerances, material, and customer drawing information.







THIS DRAWING IS UNPUBLISHED. RELEASED FOR PUBLICATION 20  
COPYRIGHT 20 BY - ALL RIGHTS RESERVED.

REVISIONS table with columns: P, LTR, DESCRIPTION, DATE, DWN, APVD. Row 1: SEE SHEET 1

Main pin-out chart table with columns for pin numbers (47-41, 38-32, 28-21, 18-12, 9-4) and rows for different assembly configurations. Includes a diagonal label 'KEYING OPTION C'.

Legend table defining symbols for 'CAVITIES WITH A NUMERIC SYMBOL INDICATES CLOSED TERMINAL LOCATIONS', 'BLANK CAVITIES INDICATES OPEN TERMINAL HOLE LOCATIONS', and 'TERMINAL HOLE POSITION'. Includes 'ASSEMBLY PART NUMBER' and 'FORD PART NUMBER' fields.

Controlled document header including 'THIS DRAWING IS A CONTROLLED DOCUMENT.', 'STE' logo, 'TE Connectivity', '50-WAY HARNESS ASSEMBLY, PCM', and technical specifications like 'DIMENSIONS: mm', 'TOLERANCES UNLESS OTHERWISE SPECIFIED: 0 PLC ±0.3', '1 PLC ±0.10', '2 PLC ±0.15', '3 PLC ±0.20', '4 PLC ±0.25', 'ANGLES FINISH'. Includes drawing ID 'A100779C=1438129' and 'SCALE 1:1 SHEET 7 OF 10'.





REVISIONS				
P.	LTN.	DESCRIPTION	DATE	APPV.
-	-	SEE SHEET 1	-	-

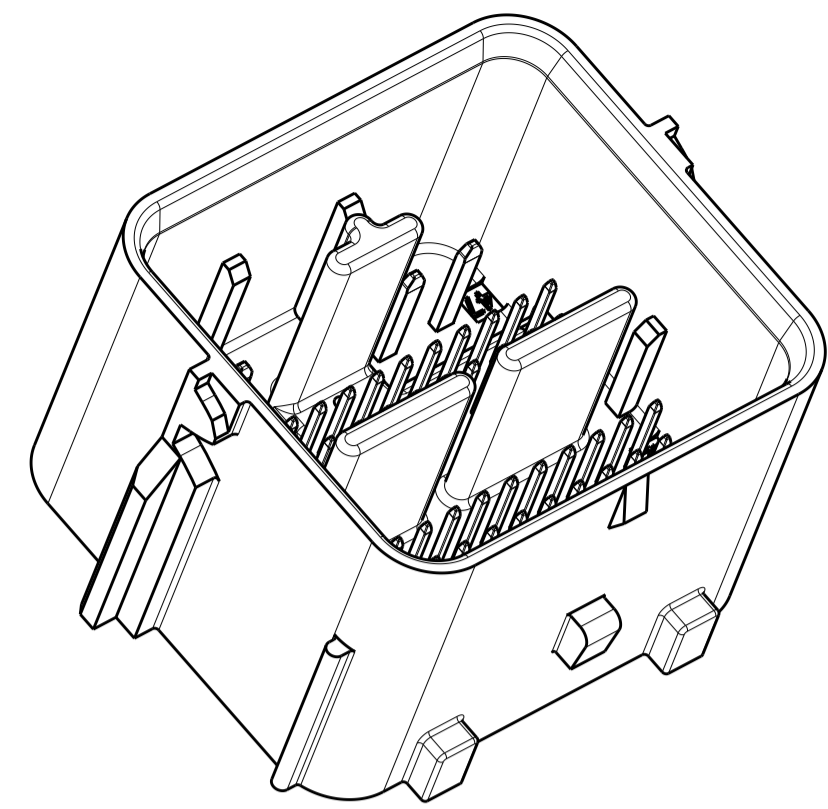

SCALE 2:1

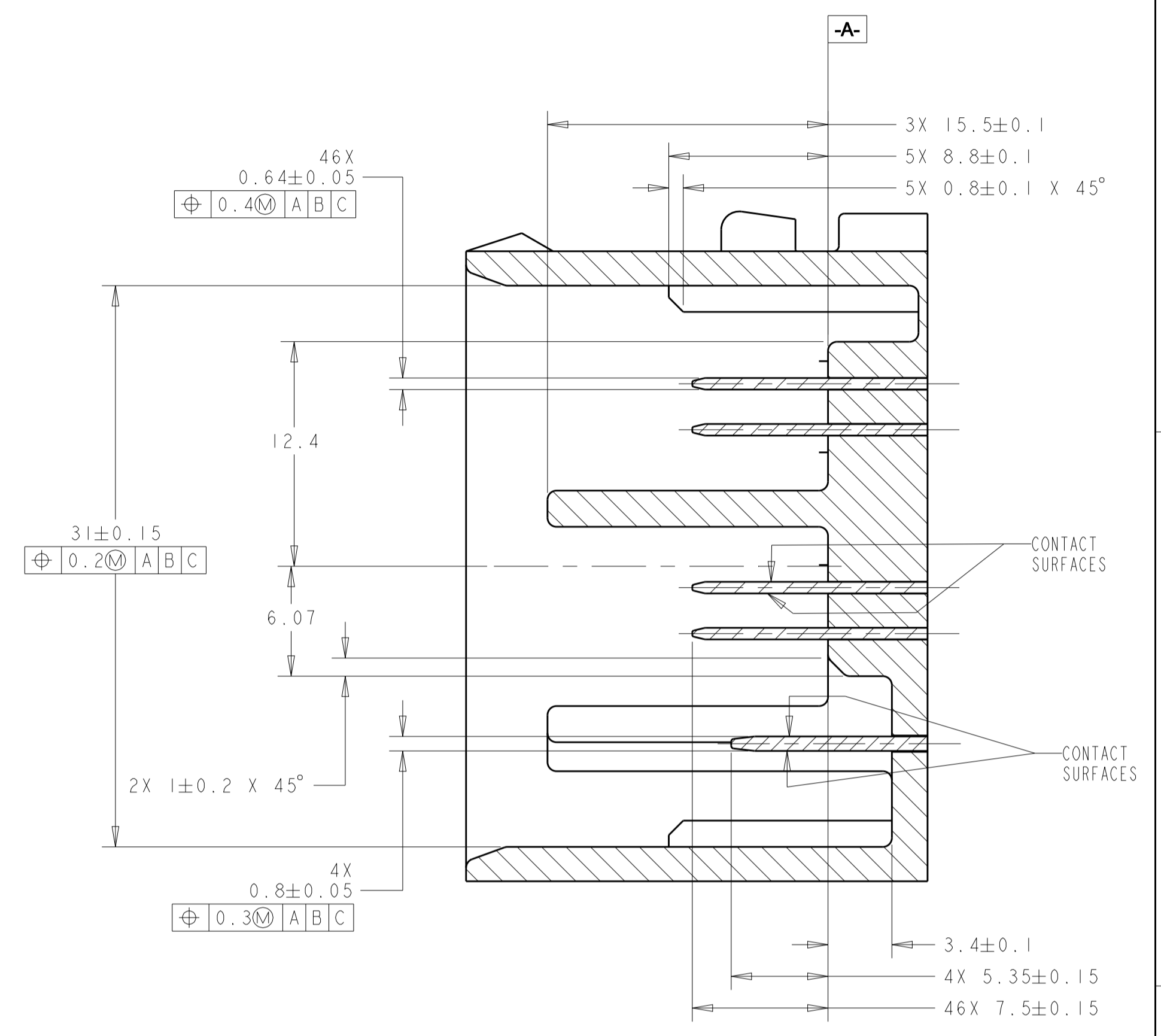
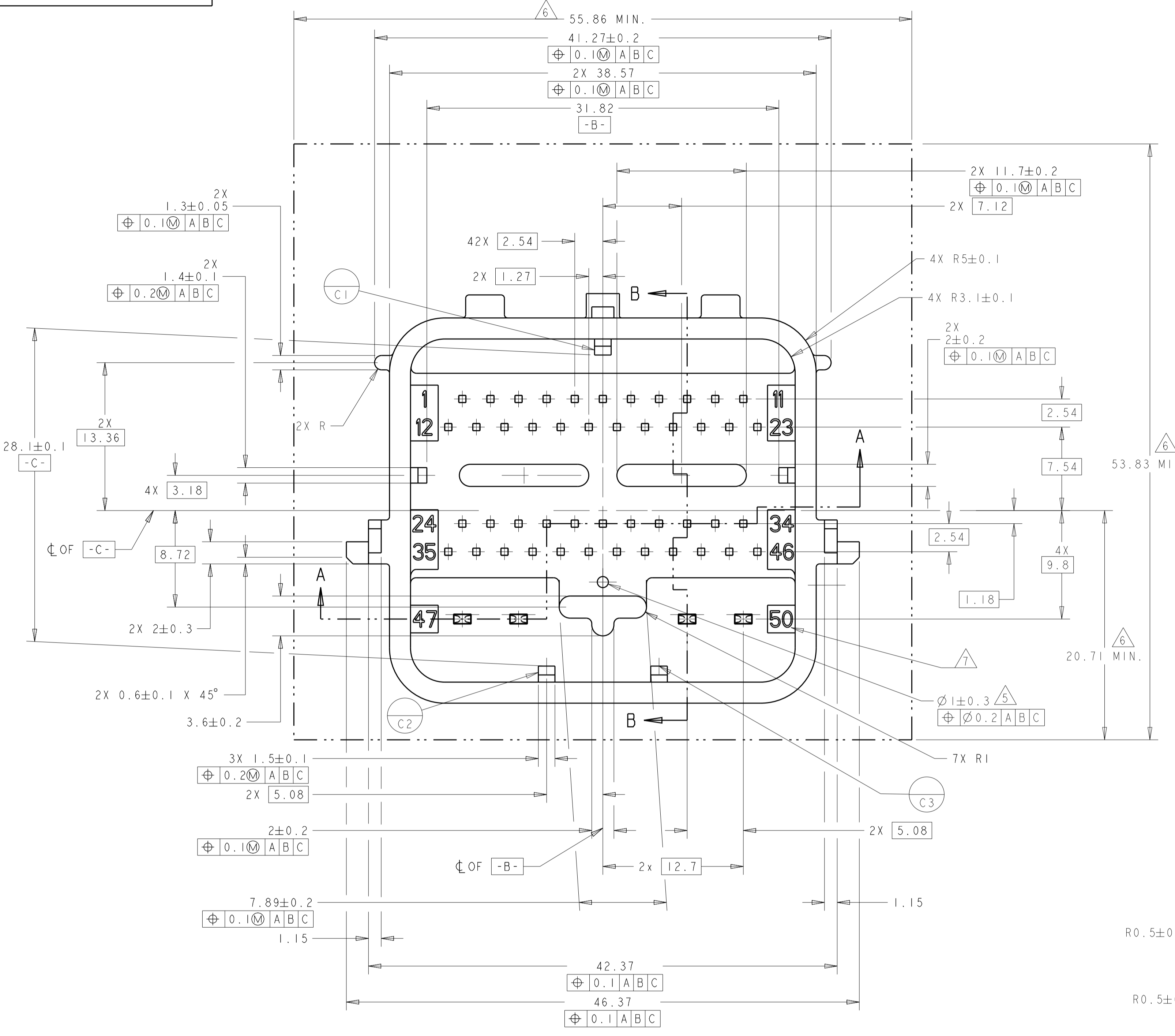

SECTION B-B

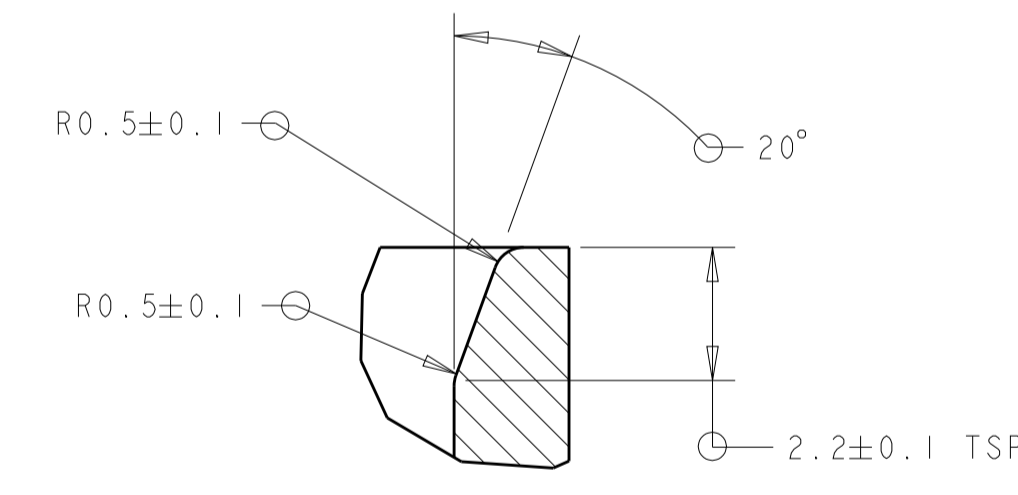

DETAIL E SCALE 8:1

- NOTES: UNLESS OTHERWISE SPECIFIED
- GENERAL TOLERANCE:  
 ±0.3 ALL ONE PLACE DIMENSIONS  
 ±0.10 ALL TWO PLACE DIMENSIONS  
 ±1°00' ALL ANGULAR DIMENSIONS
  - DRAFT ANGLE PERMISSIBLE ONLY WITHIN DRAWING TOLERANCE.
  - SEALING SURFACE, NO WITNESS LINES OR DAMAGE PERMITTED.
  - ALL UNMARKED RADII TO BE 0.5 MAX., UNLESS OTHERWISE SPECIFIED.
  - VENT HOLE SIZE AND LOCATION IS OPTIONAL.
  - THIS AREA TO REMAIN CLEAR FOR THE HARNESS ASSEMBLY.
  - TERMINAL POSITION IDENTIFICATION.
  - MATES WITH TYCO ELECTRONICS PART NUMBERS 1438129-# & 1438950-#

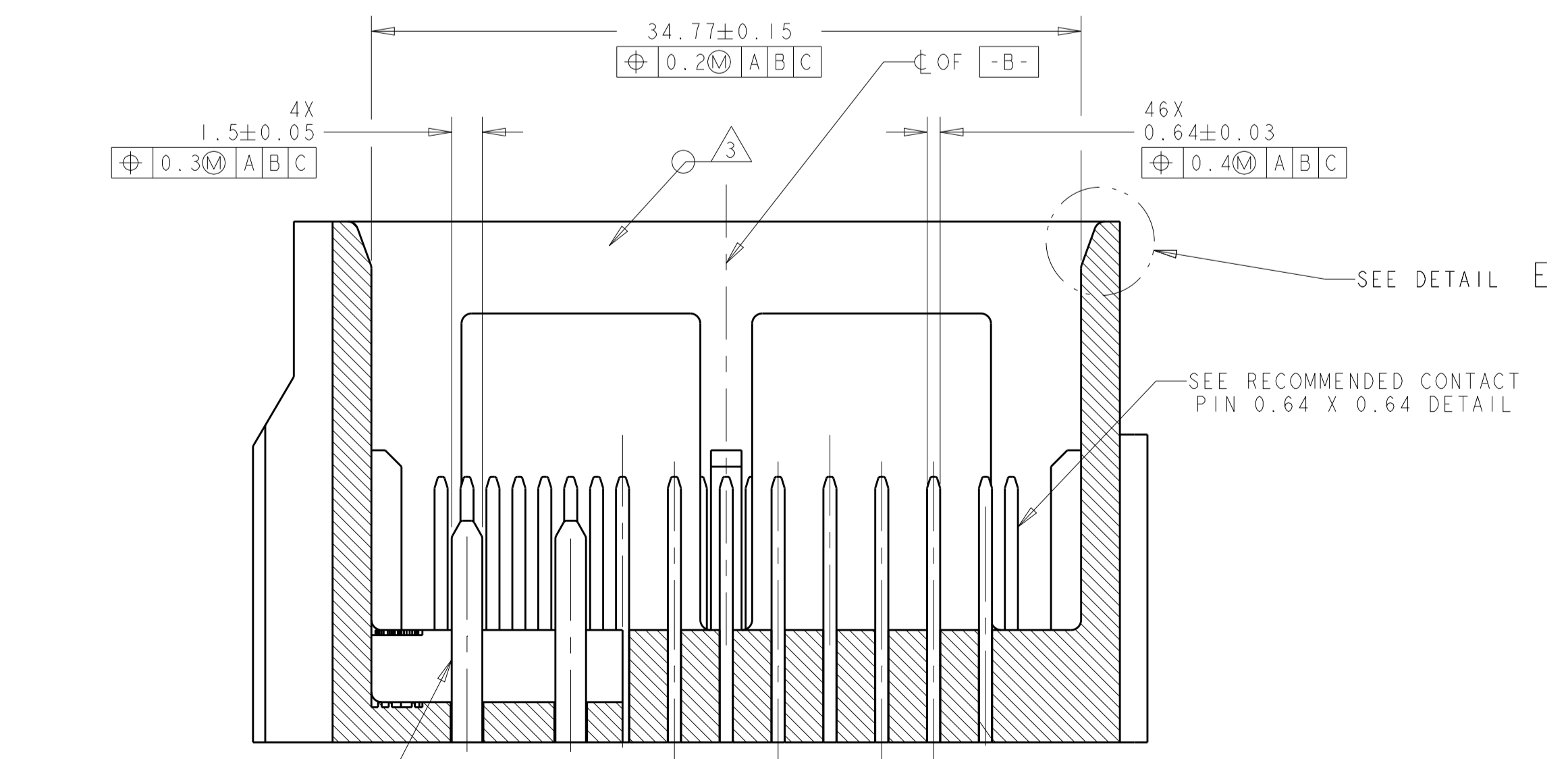

SECTION A-A

THIS DRAWING IS A CONTROLLED DOCUMENT.		OWN: R. VESTAL 15APR2005	TE Connectivity										
DIMENSIONS: mm		CHK: T. VALASEK 15APR2005											
TOLERANCES UNLESS OTHERWISE SPECIFIED:		APVD: T. VALASEK 15APR2005	NAME: 50-WAY HARNESS ASSEMBLY, PCM										
<table border="1"> <tr><td>0 PLC</td><td>±</td></tr> <tr><td>1 PLC</td><td>±0.3</td></tr> <tr><td>2 PLC</td><td>±0.10</td></tr> <tr><td>3 PLC</td><td>±</td></tr> <tr><td>4 PLC</td><td>±</td></tr> </table>		0 PLC	±	1 PLC	±0.3	2 PLC	±0.10	3 PLC	±	4 PLC	±	PRODUCT SPEC	SIZE: CAGE CODE DRAWING NO. RESTRICTED TO
0 PLC	±												
1 PLC	±0.3												
2 PLC	±0.10												
3 PLC	±												
4 PLC	±												
MATERIAL: FINISH:		APPLICATION SPEC	A100779C=1438129										
CUSTOMER DRAWING		WEIGHT:	SCALE: 1:1 SHEET 9 OF 10 REV: F35										

HEADER INTERFACE KEYING OPTIONS

REVISIONS				
P.	LTN.	DESCRIPTION	DATE	OWN. APVD.
-	-	SEE SHEET 1	-	-

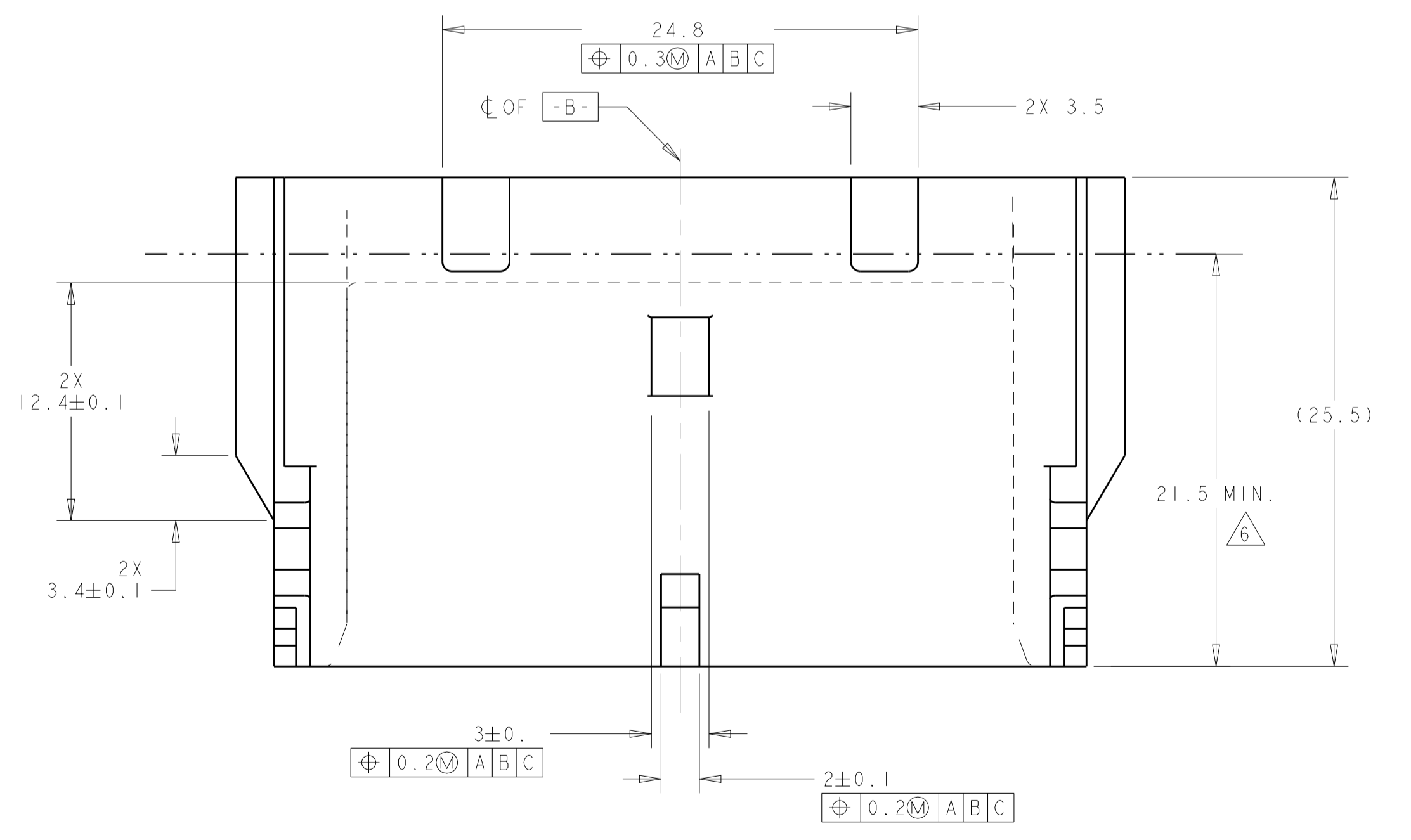
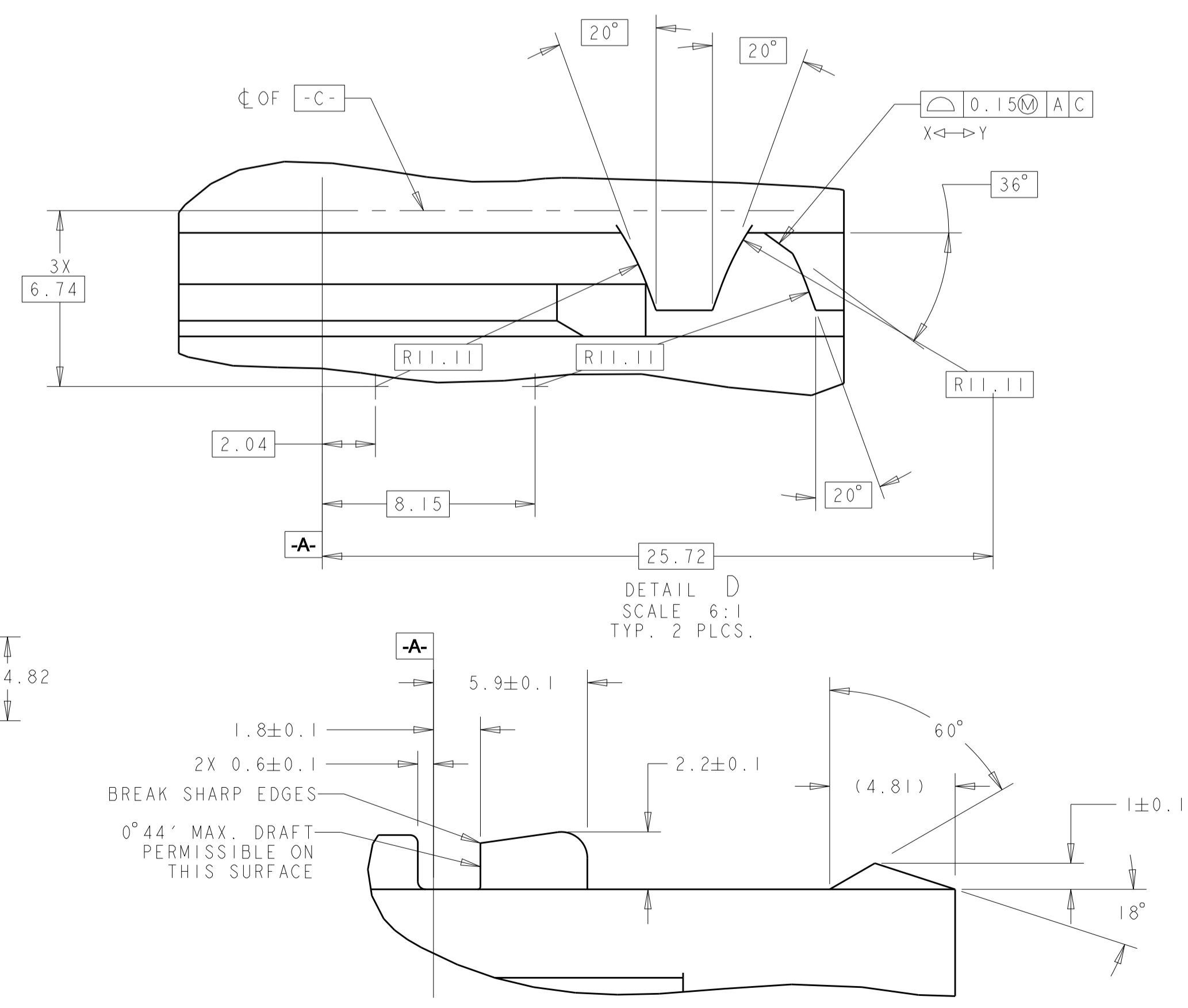
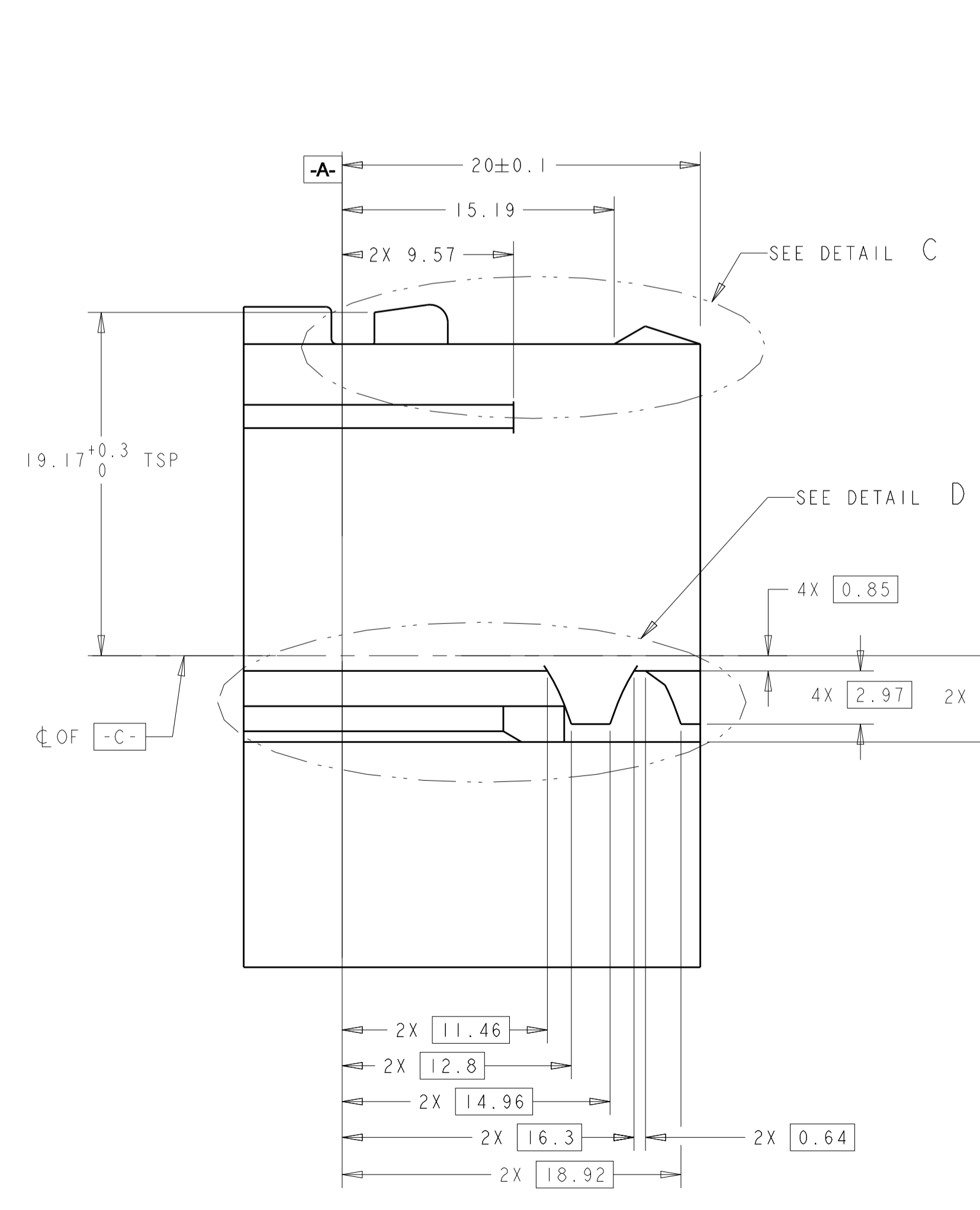
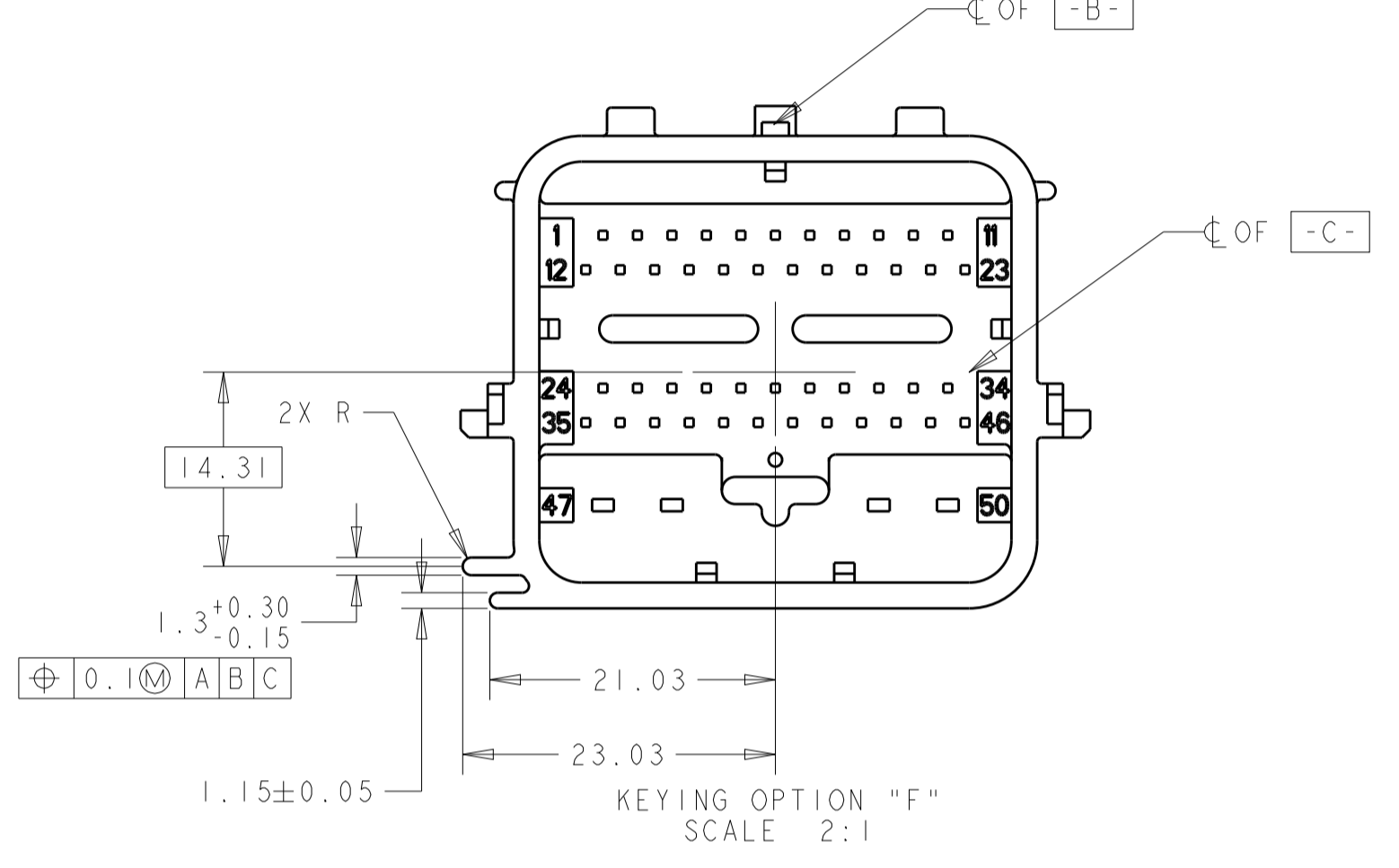
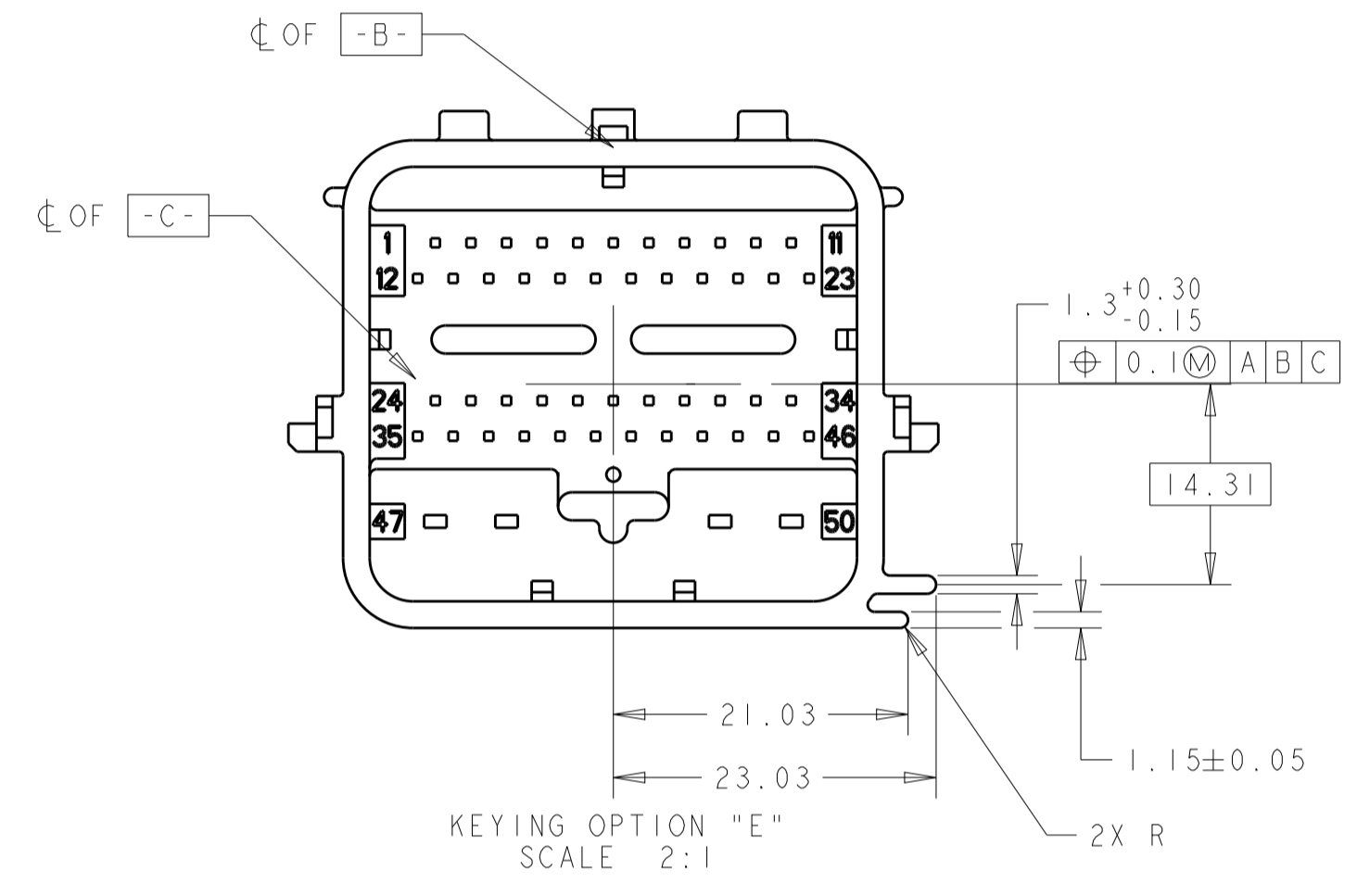
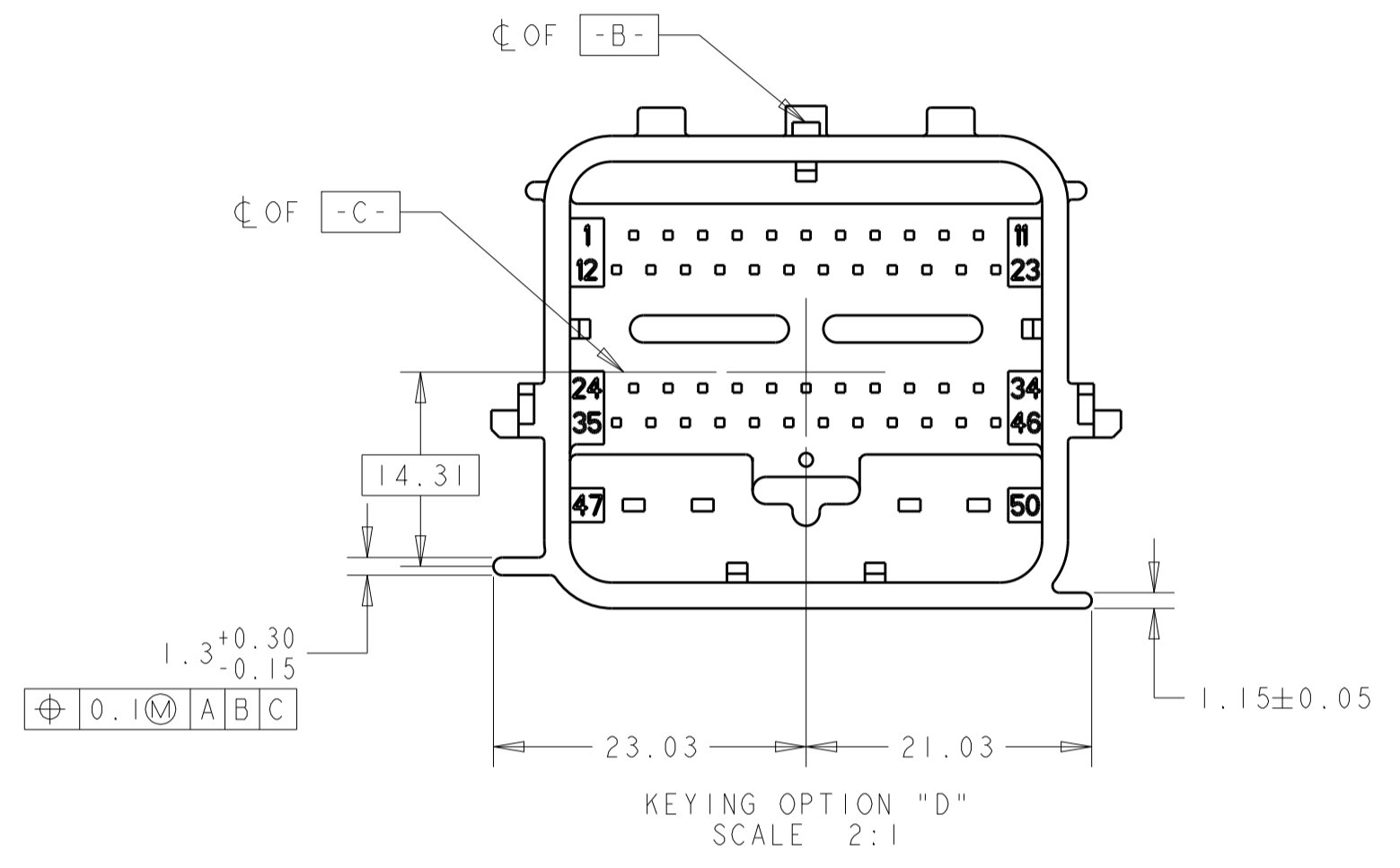
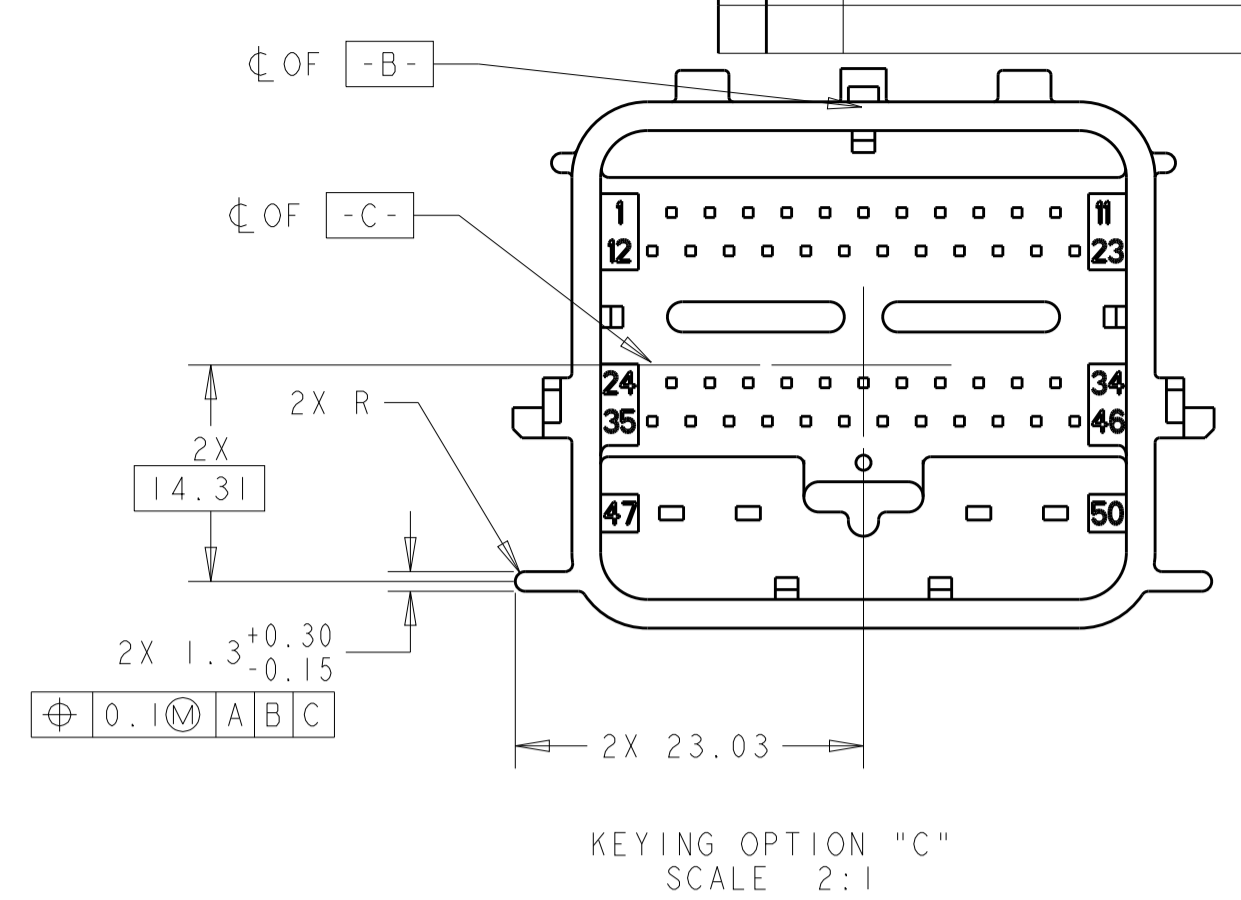
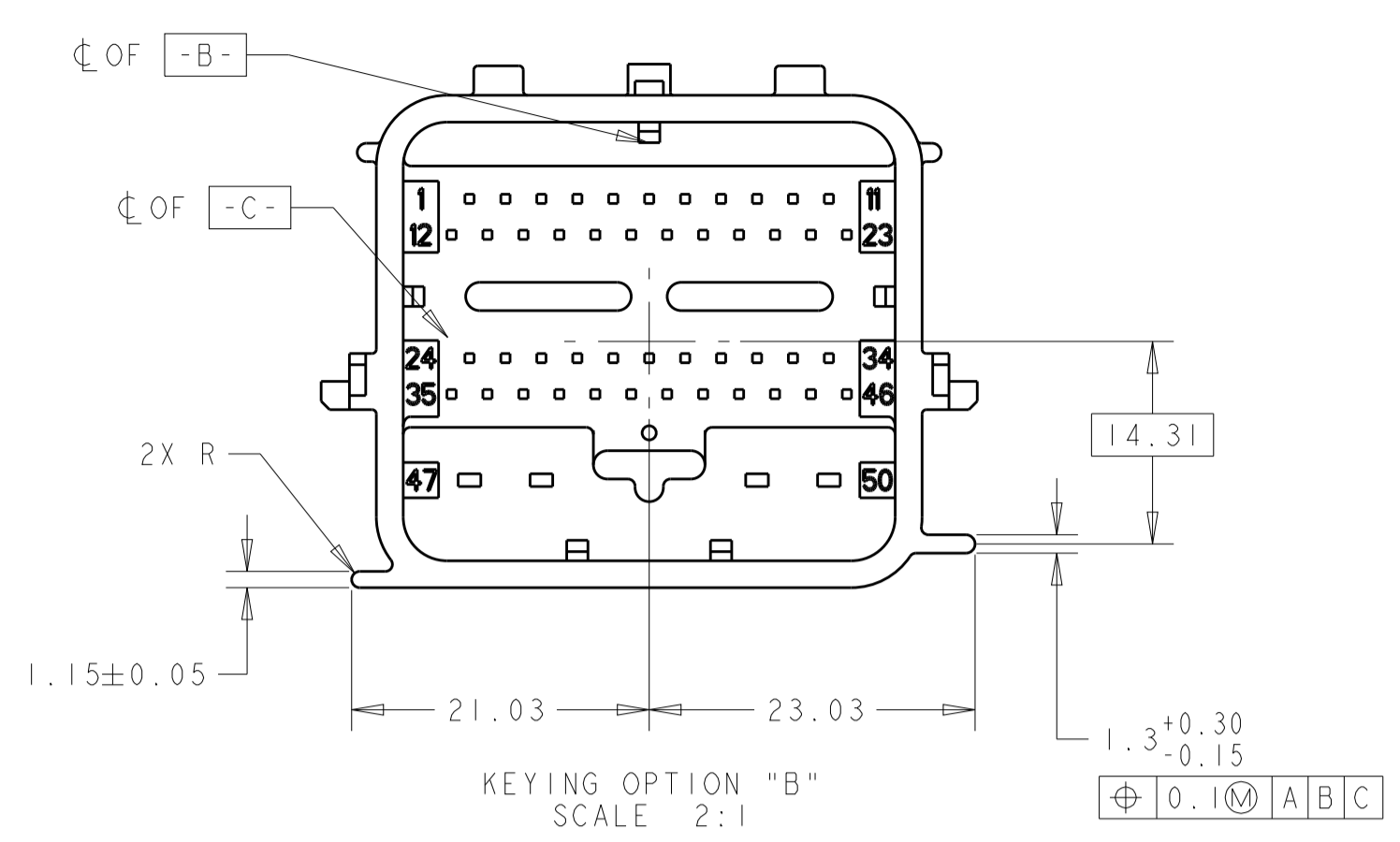
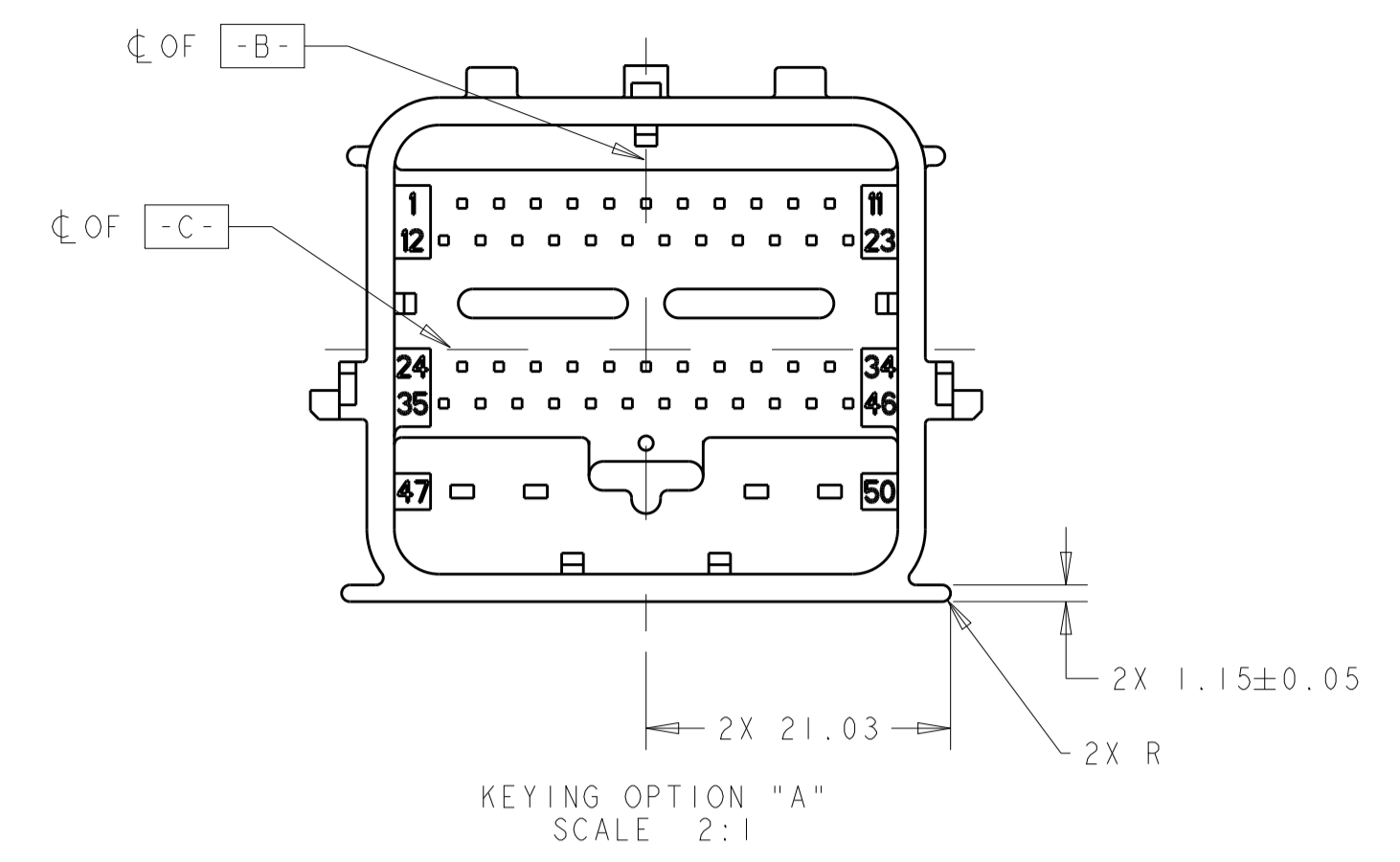

THIS DRAWING IS A CONTROLLED DOCUMENT.		OWN. R. VESTAL 15APR2005	TE Connectivity
DIMENSIONS: mm		CHK. T. VALASEK 15APR2005	
TOLERANCES UNLESS OTHERWISE SPECIFIED:		APVD. T. VALASEK 15APR2005	NAME 50-WAY HARNESS ASSEMBLY, PCM
0 PLC ±		PRODUCT SPEC	SIZE CAGE CODE DRAWING NO. RESTRICTED TO
1 PLC ±0.3		APPLICATION SPEC	A100779C=1438129
2 PLC ±0.10		WEIGHT	SCALE 1:1 SHEET 10 OF 10 REV F35
3 PLC ±		CUSTOMER DRAWING	
4 PLC ±			
ANGLES ±			
FINISH ±			

Компания «Океан Электроники» предлагает заключение долгосрочных отношений при поставках импортных электронных компонентов на взаимовыгодных условиях!

Наши преимущества:

- Поставка оригинальных импортных электронных компонентов напрямую с производств Америки, Европы и Азии, а так же с крупнейших складов мира;
- Широкая линейка поставок активных и пассивных импортных электронных компонентов (более 30 млн. наименований);
- Поставка сложных, дефицитных, либо снятых с производства позиций;
- Оперативные сроки поставки под заказ (от 5 рабочих дней);
- Экспресс доставка в любую точку России;
- Помощь Конструкторского Отдела и консультации квалифицированных инженеров;
- Техническая поддержка проекта, помощь в подборе аналогов, поставка прототипов;
- Поставка электронных компонентов под контролем ВП;
- Система менеджмента качества сертифицирована по Международному стандарту ISO 9001;
- При необходимости вся продукция военного и аэрокосмического назначения проходит испытания и сертификацию в лаборатории (по согласованию с заказчиком);
- Поставка специализированных компонентов военного и аэрокосмического уровня качества (Xilinx, Altera, Analog Devices, Intersil, Interpoint, Microsemi, Actel, Aeroflex, Peregrine, VPT, Syfer, Eurofarad, Texas Instruments, MS Kennedy, Miteq, Cobham, E2V, MA-COM, Hittite, Mini-Circuits, General Dynamics и др.);

Компания «Океан Электроники» является официальным дистрибьютором и эксклюзивным представителем в России одного из крупнейших производителей разъемов военного и аэрокосмического назначения «JONHON», а так же официальным дистрибьютором и эксклюзивным представителем в России производителя высокотехнологичных и надежных решений для передачи СВЧ сигналов «FORSTAR».



## JONHON

«JONHON» (основан в 1970 г.)

Разъемы специального, военного и аэрокосмического назначения:

(Применяются в военной, авиационной, аэрокосмической, морской, железнодорожной, горно- и нефтедобывающей отраслях промышленности)

«FORSTAR» (основан в 1998 г.)

ВЧ соединители, коаксиальные кабели, кабельные сборки и микроволновые компоненты:

(Применяются в телекоммуникациях гражданского и специального назначения, в средствах связи, РЛС, а так же военной, авиационной и аэрокосмической отраслях промышленности).



Телефон: 8 (812) 309-75-97 (многоканальный)

Факс: 8 (812) 320-03-32

Электронная почта: [ocean@oceanchips.ru](mailto:ocean@oceanchips.ru)

Web: <http://oceanchips.ru/>

Адрес: 198099, г. Санкт-Петербург, ул. Калинина, д. 2, корп. 4, лит. А