

ISL6238xxxEVAL1Z

ISL62381, ISL62382 Quad-Output Evaluation Board User Guide

AN1396  
Rev 0.00  
July 31, 2008

The ISL62381 and ISL62382 evaluation boards demonstrate the performance of ISL62381 and ISL62382 Quad-output controllers. The ISL62381 and ISL62382 controller include two pulse-width modulation (PWM) controllers featured with Intersil's patented R<sup>3</sup> technology, adjustable from 0.6V to 5.5V, and two linear regulators, LDO5 and LDO3, that generate a fixed 5V and an adjustable output respectively.

The evaluation board includes two independent Enable switches, two LED Power-Good indicators and various test points. Included with each switching channel is an on-board dynamic load generator for evaluating the transient-load response. There are four different evaluation boards which provide flexible evaluation options. Table 1 shows a brief description of the evaluation boards.

TABLE 1. EVALUATION BOARD DESCRIPTION

EVALUATION BOARD	CHANNEL-1	CHANNEL-2	OCP
ISL62381LOEVAL1Z	3.3V/8A	5V/8A	~10A
ISL62381HIEVAL1Z	1.05V/15A	1.5V/15A	~20A
ISL62382LOEVAL1Z	3.3V/8A	5V/8A	~10A
ISL62382HIEVAL1Z	1.05V/15A	1.5V/15A	~20A

**What's Inside**

The Evaluation Board Kit contains the following materials:

- ISL6238xxxEVAL1Z Evaluation Board
- ISL62381 and ISL62382 Datasheet
- ISL62381 And ISL62382 Evaluation Board User Guide (this document)

**What's Needed**

The following materials will be needed to perform testing:

- Adjustable +25V, 30A Power Supply
- +12V, 100mA Power Supply
- Precision digital multi-meter
- 4 Electronic Loads
- 4-Channel Oscilloscope

**Enable Control**

The evaluation board provides flexible control logic to enable or disable the outputs, and to program the two PWM channels' start-up sequence. For start-up timing sequence, please refer to the datasheet waveforms. Table 2 is the Enable controller truth table.

TABLE 2. ENABLE TRUTH TABLE

EN1	EN2	START-UP SEQUENCE
Low	Low	Both Channel outputs OFF simultaneously
Low	Float	Both Channel outputs OFF simultaneously
Float	Low	Both Channel outputs OFF simultaneously
Float	Float	Both Channel outputs OFF simultaneously
Low	High	Channel-1 OFF, Channel-2 ON
High	Low	Channel-1 ON, Channel-2 OFF
High	High	Both Channel outputs ON simultaneously
Float	High	Channel-1 enabled after Channel-2 is in regulation
High	Float	Channel-2 enabled after Channel-1 is in regulation

**Resistor Current Sense Configuration**

The evaluation board is pre-configured with inductor DCR current sense. For more precise overcurrent protection, it also provides the option of resistor current sense. Figure 1 shows the configuration for resistor current sense.

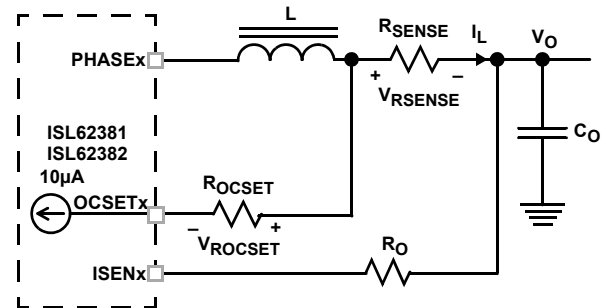

FIGURE 1. RESISTOR CURRENT SENSE CIRCUIT

For Channel-1, the ISL62381 and ISL62382 monitors the OCSET1 pin and the ISEN1 pin voltages. Once the OCSET1 pin voltage is higher than the ISEN1 pin voltage for more than 10µs, the ISL62381 and ISL62382 declare an overcurrent fault. For a chosen overcurrent, set point I<sub>OC</sub> and current sense resistor R<sub>SENSE</sub>, the value of R<sub>OCSET</sub> is determined by Equation 1

$$R_{OCSET} = \frac{I_{OC} \cdot R_{SENSE}}{10\mu A} \quad (EQ. 1)$$

Where:

- R<sub>OCSET</sub> (Ω) is the resistor used to program the overcurrent setpoint
- I<sub>OC</sub> is the output current threshold that will activate the OCP circuit
- R<sub>SENSE</sub> is current sense resistor (R<sub>3</sub> for Channel-1 and R<sub>25</sub> for Channel-2)

Take Channel-1 as an example, once the value of  $R_{OCSET}$  is calculated, follow the following procedure to configure the resistor current sense circuit:

- Step 1:** Open the “DCR SENSE” solder bridge and connect the “RESISTOR SENSE” solder bridge on the PCB bottom layer;
- Step 2:** Remove  $R_7$  ( $R_{22}$  for Channel 2);
- Step 3:** Replace  $R_3$  ( $R_{25}$  for Channel 2) with  $R_{SENSE}$ ;
- Step 4:** Replace  $C_6$  ( $C_{25}$  for Channel 2) with  $R_{OCSET}$ ;
- Step 5:** Replace replace  $R_{19}$  ( $R_{18}$  for Channel 2) with  $R_{OCSET}$ .

## Dynamic Load Generator

The evaluation board provides each PWM channel an on-board dynamic load generator for evaluating the transient-load response, which are controlled by SW1 and SW2 respectively. The dynamic load generator applies a 300 $\mu$ s pulse load across  $V_{OUT}$  and GND. The transient load slew-rate can be trimmed by adjusting the resistors  $R_{34}$ ,  $R_{40}$  for the rising edge, and  $R_{38}$ ,  $R_{39}$  for the falling edge. +12V power supply is needed to power the dynamic load generator.

## Connections and Test Points

The following table describes the function and operation of the evaluation boards.

NUMBER	NAME	FUNCTION/OPERATION
<b>INTERFACES AND CONNECTIONS</b>		
TP3	VBAT	$V_{IN}$ positive power input
TP4	GND	$V_{IN}$ return power input
TP1	VOUT1	Channel-1 positive power output
TP2	GND	Channel-1 return power output
TP11	VOUT2	Channel-2 positive power output
TP12	GND	Channel-2 return power output
TP20	+12V	+12V positive power input, used for the power supply of the on-board dynamic-load generator
TP19	GND	+12V return power input
<b>TEST POINTS</b>		
J1	PHASE2	Scope-probe socket for measuring Channel-2 phase node
J3	PHASE1	Scope-probe socket for measuring Channel-1 phase node
J2	VOUT1	Scope-probe socket for measuring Channel-1 output
J5	VOUT2	Scope-probe socket for measuring Channel-2 output
J4	FLOAT_FCCM	Remove the jumper will float the FCCM pin
J6	FLOAT_EN1	Remove the jumper will float the EN1 pin
J7	FLOAT_EN2	Remove the jumper will float the EN2 pin
TP17	EN1	Test point of EN1 pin
TP8	EN2	Test point of EN2 pin
TP9	LDO3EN	Test point of LDO3EN pin
TP10	FCCM	Test point of FCCM pin
<b>POWER-GOOD INDICATORS</b>		
TP13	PGOOD1	Test point of PGOOD1 pin
TP5	PGOOD2	Test point of PGOOD2 pin
D1		Channel-1 Power-Good indicator. Green when VOUT1 is in regulation.
D2		Channel-2 Power-Good indicator. Green when VOUT2 is in regulation.
<b>LINEAR REGULATORS</b>		
TP14	LDO5	LDO5 linear regulator positive power output
TP15	GND	LDO5 linear regulator return power output
TP16	LDO3IN	Input of LDO3 linear regulator. Connect to connected to a voltage greater than the LDO3 set point plus the dropout voltage.
TP18	LDO3FB	LDO3 linear regulator output voltage feedback test point
TP6	LDO3	LDO3 linear regulator positive power output
TP7	GND	LDO3 linear regulator return power output

**Connections and Test Points** The following table describes the function and operation of the evaluation boards. **(Continued)**

SWITCHES		
SW1		ON/OFF control of Channel-2 dynamic-load generator. Toggle to ON will enable the dynamic load, toggle to OFF will disable the transient load
SW2		ON/OFF control of Channel-1 dynamic-load generator. Toggle to ON will enable the dynamic load, toggle OFF will disable the transient load
U2		ON: High level for EN1, EN2, LDO3EN and FCCM, respectively OFF: Low level for EN1, EN2, LDO3EN and FCCM, respectively

**Test Set-up**

Figure 2 shows a typical test configuration.

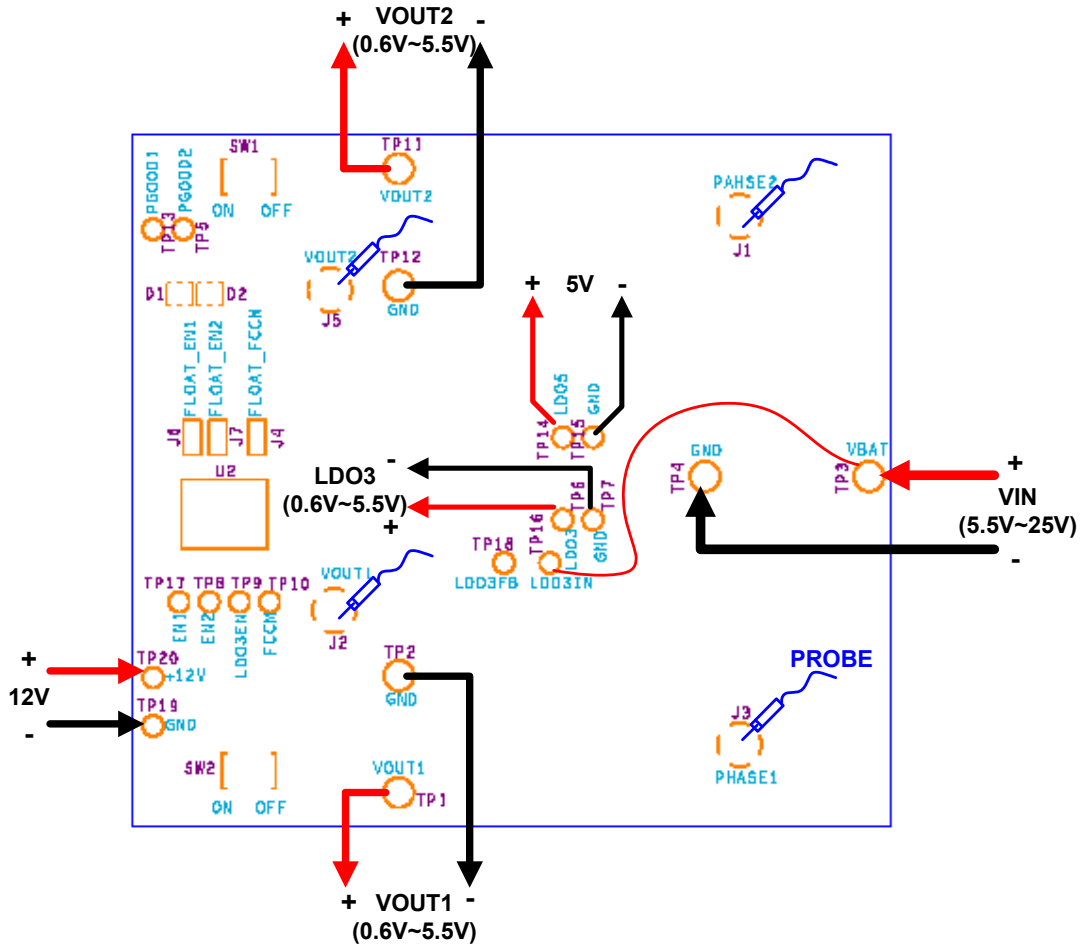

FIGURE 2. TYPICAL TEST CONFIGURATION

**ISL62381LOEVAL1Z, ISL62382LOEVAL1Z Evaluation Board Bill of Materials**

ISL62381LOEVAL1Z and ISL62382LOEVAL1Z evaluation boards use the same PCB and schematic, thus the same bill of materials except for the controller U1.

NO.	REFERENCE DESIGNATOR	QTY	VALUE	VOLTAGE/ POWER	TOL. (%)	MANUFACTURER	DESCRIPTION
1	C6, C25	2	0.022 $\mu$ F	25V	10	GENERIC	SM_CAP_0603, 0.022 $\mu$ F, 25V, 10%, X7R, ROHS
2	C8, C9	2	0.01 $\mu$ F	16V	10	GENERIC	SM_CAP_0603, 0.01 $\mu$ F, 16V, 10%, X7R, ROHS
3	C17, C19	2	0.22 $\mu$ F	16V	10	GENERIC	SM_CAP_0603, 0.22 $\mu$ F, 16V, 10%, X7R, ROHS
4	C13, C15, C22, C23	4	10 $\mu$ F	25V	10	GENERIC	SM_CAP_1206, 10 $\mu$ F, 25V, 10%, X7R, ROHS
5	C12, C14	2	1200pF	16V	10	GENERIC	SM_CAP_0603, 1200PF, 16V, 10%, X7R, ROHS
6	C7, C10	2	1 $\mu$ F	10V	10	GENERIC	SM_CAP_0603, 1 $\mu$ F, 10V, 10%, X7R, ROHS
7	C30	1	1 $\mu$ F	25V	10	GENERIC	SM_CAP_0805, 1 $\mu$ F, 25V, 10%, X7R, ROHS
8	C11, C24	2	1 $\mu$ F	25V	10	GENERIC	SM_CAP_1206, 1 $\mu$ F, 25V, 10%, X7R, ROHS
9	C1, C2, C28, C29	4	4.7 $\mu$ F	10V	10	GENERIC	SM_CAP_0805, 4.7 $\mu$ F, 10V, 10%, X7R, ROHS
10	C20, C21	2	4.7 $\mu$ F	10V	10	GENERIC	SM_CAP_1206, 4.7 $\mu$ F, 10V, 10%, X7R, ROHS
11	C16, C18, C31, C32	4	10 $\mu$ F	16V	10	GENERIC	SM_CAP_0805, 10 $\mu$ F, 16V, 10%, X5R, ROHS
12	C3	1	56 $\mu$ F	25V	20	SANYO-OSCON	RADIAL_POLCAP_RADIAL, 25SP56M, 56 $\mu$ F, 25V, 20%, CASE-CC
13	C4, C26	2	330 $\mu$ F	6.3V	10	SANYO-POSCAP	SM_POLCAP_SMD, 6TPF330M9L, 330UF, 6.3V, 10%, CAP_7343
14	R12, R15	2	750	1/10W	1	GENERIC	SM_RES_0603, 750, 1/10W, 1%, TF, ROHS
15	R11, R30	2	10k	1/10W	1	GENERIC	SM_RES_0603, 10k, 1/10W, 1%, TF, ROHS
16	R14	1	9.09k	1/10W	1	GENERIC	SM_RES_0603, 9.09k, 1/10W, 1%, TF, ROHS
17	R13	1	68.1k	1/10W	1	GENERIC	SM_RES_0603, 68.1k, 1/10W, 1%, TF, ROHS
18	R7, R18, R19, R22	4	15.8k	1/10W	1	GENERIC	SM_RES_0603, 15.8k, 1/10W, 1%, TF, ROHS
19	R29	1	17.4k	1/10W	1	GENERIC	SM_RES_0603, 17.4k, 1/10W, 1%, TF, ROHS
20	R8	1	19.6k	1/10W	1	GENERIC	SM_RES_0603, 19.6k, 1/10W, 1%, TF, ROHS
21	R9	1	24.3k	1/10W	1	GENERIC	SM_RES_0603, 24.3k, 1/10W, 1%, TF, ROHS
22	R16	1	45.3k	1/10W	1	GENERIC	SM_RES_0603, 45.3k, 1/10W, 1%, TF, ROHS
23	R20, R33, R39	3	1k	1/10W	1	GENERIC	SM_RES_0603, 1k, 1/10W, 1%, TF, ROHS
24	R38	1	1.58k	1/10W	1	GENERIC	SM_RES_0603, 1.58k, 1/10W, 1%, TF, ROHS
25	R17, R32	2	48.7k	1/10W	1	GENERIC	SM_RES_0603, 48.7k, 1/10W, 1%, TF, ROHS
26	R1, R2, R10	3	0	1/10W	1	GENERIC	SM_RES_0603, 0, 1/10W, 1%, TF, ROHS
27	R34, R40	2	200	1/10W	1	GENERIC	SM_RES_0603, 200, 1/10W, 1%, TF, ROHS
28	R5, R27	2	499	1/10W	1	GENERIC	SM_RES_0603, 499, 1/10W, 1%, TF, ROHS
29	R6, R21, R23, R24, R28, R31	6	100k	1/10W	1	GENERIC	SM_RES_0603, 100k, 1/10W, 1%, TF, ROHS
30	R35	1	0.7	1W	1	GENERIC	SM_RES_2512, 0.7, 1W, 1%, TF, ROHS
31	R37	1	0.5	1W	1	GENERIC	SM_RES_2512, 0.5, 1W, 1%, TF, ROHS
32	D1, D2	2	SSL_LXA3025IGC			LUMEX	SSL_LXA3025IGC_SMD-SSL-LXA3025IGC, LED_3x2_5MM
33	D3, D4	2	BAT54S			DIODES	SM_SCHOTTKY_BAT54S-BAT54S, SOT23
34	Q2, Q4	2	IRF7821PBF			IR	30V 13.6A N-Channel HEXFET Power MOSFET (Pb-free)

**ISL62381LOEVAL1Z, ISL62382LOEVAL1Z Evaluation Board Bill of Materials**

ISL62381LOEVAL1Z and ISL62382LOEVAL1Z evaluation boards use the same PCB and schematic, thus the same bill of materials except for the controller U1. (Continued)

NO.	REFERENCE DESIGNATOR	QTY	VALUE	VOLTAGE/ POWER	TOL. (%)	MANUFACTURER	DESCRIPTION
35	Q3, Q5	2	IRF7832PBF			IR	30V 20A N-Channel HEXFET Power MOSFET (Pb-FREE)
36	Q1, Q6, Q10, Q12	4	2N7002-7-F			FAIRCHILD	2N7002_SOT23-2N7002-7-F,SOT23
37	Q11, Q13	2	SUD50N03-07			VISHAY	SUD50N03_07_TO252-SUD50N03-07, TO-252AA
38	SW1, SW2	2	GT11MSCBE-T			C&K	GT11MSCKE_SMT-GT11MSCBE-T, GT13MSCKE
39	TP5, TP6, TP7, TP8, TP9, TP10, TP13, TP14, TP15, TP16, TP17, TP18, TP19,	14	5002			KEYSTONE	TEST_POINT_THOLE-5002,MTP500X
40	TP1, TP2, TP3, TP4, TP11, TP12	6	1514-2			KEYSTONE	TEST_POINT_THOLE-1514-2,TP-150C100P
41	J1, J2, J3, J5	4	131-5031-00			TEKTRONIX	SCOPE_PROBE_5P_CONN-131-5031-00, TEK131-5031-00
42	J4, J6, J7	3	68000-236			FCI	CONN2_DIP2-68000-236, CONN2
43	U2	1	78B04S			GRAYHILL	DIP_SW4_SPST_DIP-78B04S, DIP8-SW4
44	U1	1	ISL62381HRTZ (ISL62382HRTZ)			INTERSIL	ISL62381HRTZ, 32 LD 5x5 TQFN (ISL62382HRTZ, 32 LD 5x5 TQFN)
45	U3, U4	2	HIP2100IBZ			INTERSIL	HIP2100_SOIC-HIP2100IBZ,SOIC8_150_50
46	L1, L2	2	4.7µH		20%	VISHAY	VISHAY_IHLP_5050CE_SMT-20%-IHLP-5050CE-01-4R7M, 4.7µH, 24A, 20%, VISHAY_IHLP-5050CE
47	R3, R25	2	Wire			GENERIC	Wire short
48	DCR SENSE	4	Wire			GENERIC	Wire short
49	Jumper Connector	3	SPC02SYAN			SULLINS	Connector Jumper for J4, J6, J7
50		1	PCB			TBD	ISL62381EVAL1ZREVA PCB
51		1	Label			TBD	LABEL, FOR SERIAL NUMBER AND BOM REV #
52	C5, C27, C33, C34, C35, C36	6	No-pop				
53	R4, R26, R36, R41	4	No-pop				
54	Q7, Q8, Q9, Q14	4	No-pop				

**ISL62381HIEVAL1Z, ISL62382HIEVAL1Z Evaluation Board Bill of Materials**

The ISL62381HIEVAL1Z, ISL62382HIEVAL1Z evaluation boards use the same PCB and schematic as the ISL62381LOEVAL1Z, ISL62382LOEVAL1Z evaluation boards but different bill of materials (BOM). The following table shows the BOM difference of ISL62381HIEVAL1Z, ISL62382HIEVAL1Z in comparison with ISL62381LOEVAL1Z, ISL62382LOEVAL1Z.

NO.	REFERENCE DESIGNATOR	QTY	VALUE	VOLTAGE /POWER	TOL. (%)	MANUFACTURER	DESCRIPTION
1	Q8, Q14	2	IRF7821PBF			IR	30V 13.6A N-Channel HEXFET Power MOSFET (Pb-free)
2	Q7, Q9	2	IRF7832PBF			IR	30V 20A N-Channel HEXFET Power MOSFET (Pb-free)
3	R8	1	14k	1/10W	1	GENERIC	SM_RES_0603, 14k, 1/10W, 1%, TF, ROHS
4	R9	1	17.4k	1/10W	1	GENERIC	SM_RES_0603, 17.4k, 1/10W, 1%, TF, ROHS
5	R11	1	23.2k	1/10W	1	GENERIC	SM_RES_0603, 23.2k, 1/10W, 1%, TF, ROHS
6	R16	1	17.8k	1/10W	1	GENERIC	SM_RES_0603, 17.8k, 1/10W, 1%, TF, ROHS
7	R13	1	15k	1/10W	1	GENERIC	SM_RES_0603, 15k, 1/10W, 1%, TF, ROHS
8	R14	1	10k	1/10W	1	GENERIC	SM_RES_0603, 10k, 1/10W, 1%, TF, ROHS
9	R7, R18, R19, R22	4	16.2k	1/10W	1	GENERIC	SM_RES_0603, 16.2k, 1/10W, 1%, TF, ROHS
10	R35	1	0.2	1W	1	GENERIC	SM_RES_2512, 0.2, 1W, 1%, TF, ROHS
11	R37	1	0.1	1W	1	GENERIC	SM_RES_2512, 0.1, 1W, 1%, TF, ROHS
12	R38	1	4.02k	1/10W	1	GENERIC	SM_RES_0603, 4.02k, 1/10W, 1%, TF, ROHS
13	R12, R15	2	590	1/10W	1	GENERIC	SM_RES_0603, 590, 1/10W, 1%, TF, ROHS
14	C12, C14	2	1800pF	16V	10	GENERIC	SM_CAP_0603, 1800PF, 16V, 10%, X7R, ROHS
15	C33, C36	2	330µF	6.3V	10	SANYO-POSCAP	SM_POLCAP_SMD, 6TPF330M9L, 330µF, 6.3V, 10%, CAP_7343
16	L1, L2	2	2.2µH		20	VISHAY	VISHAY_IHLP_5050CE_SMT-20%-IHLP-5050CE-01-2R2M,2.2µH, 29A, 20%, VISHAY_IHLP-5050CE

# ISL6238xxx EVAL 1Z Evaluation Board Schematic

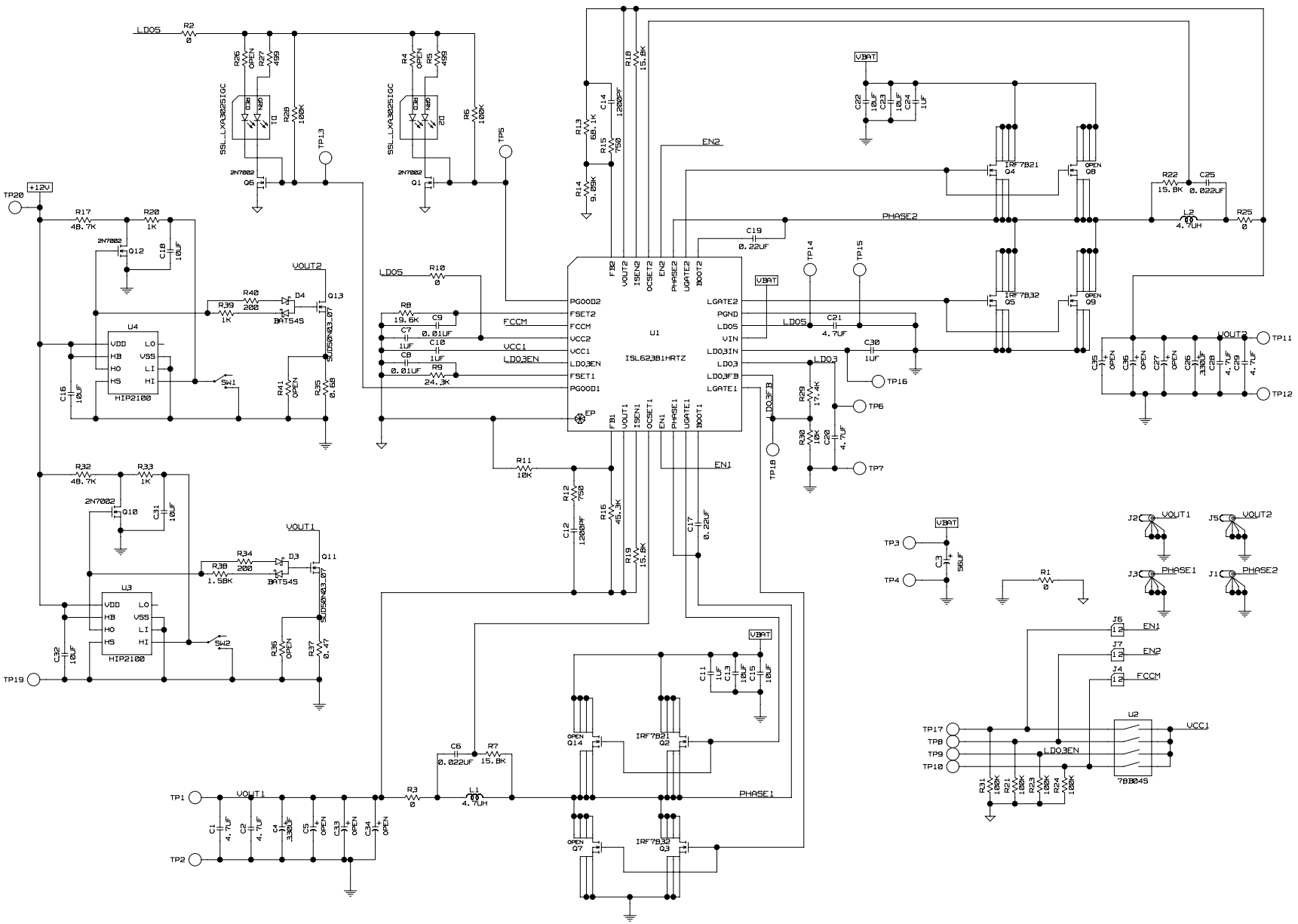

**ISL6238xxxEVAL1Z Evaluation Board Layout**

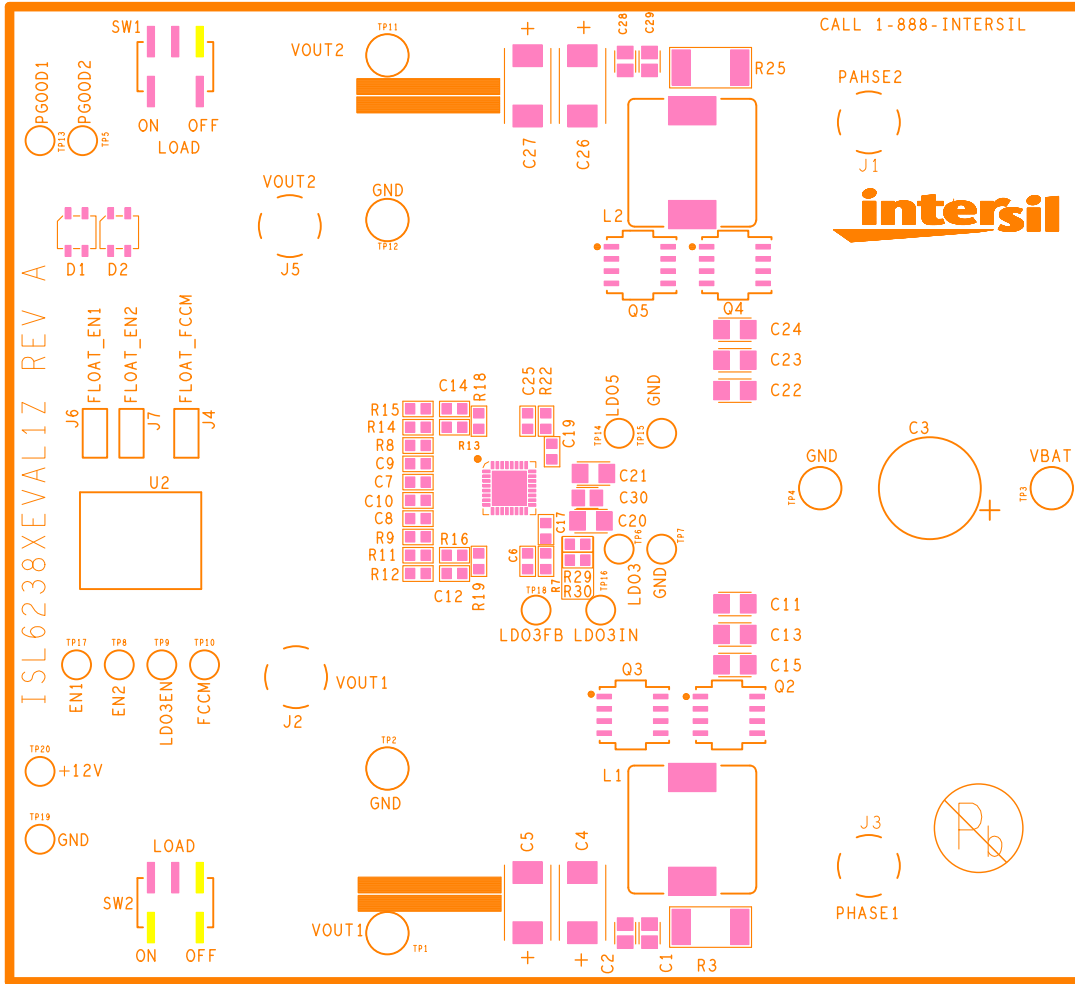

**FIGURE 3. TOP SILKSCREEN**



**ISL6238xxxEVAL1Z Evaluation Board Layout (Continued)**

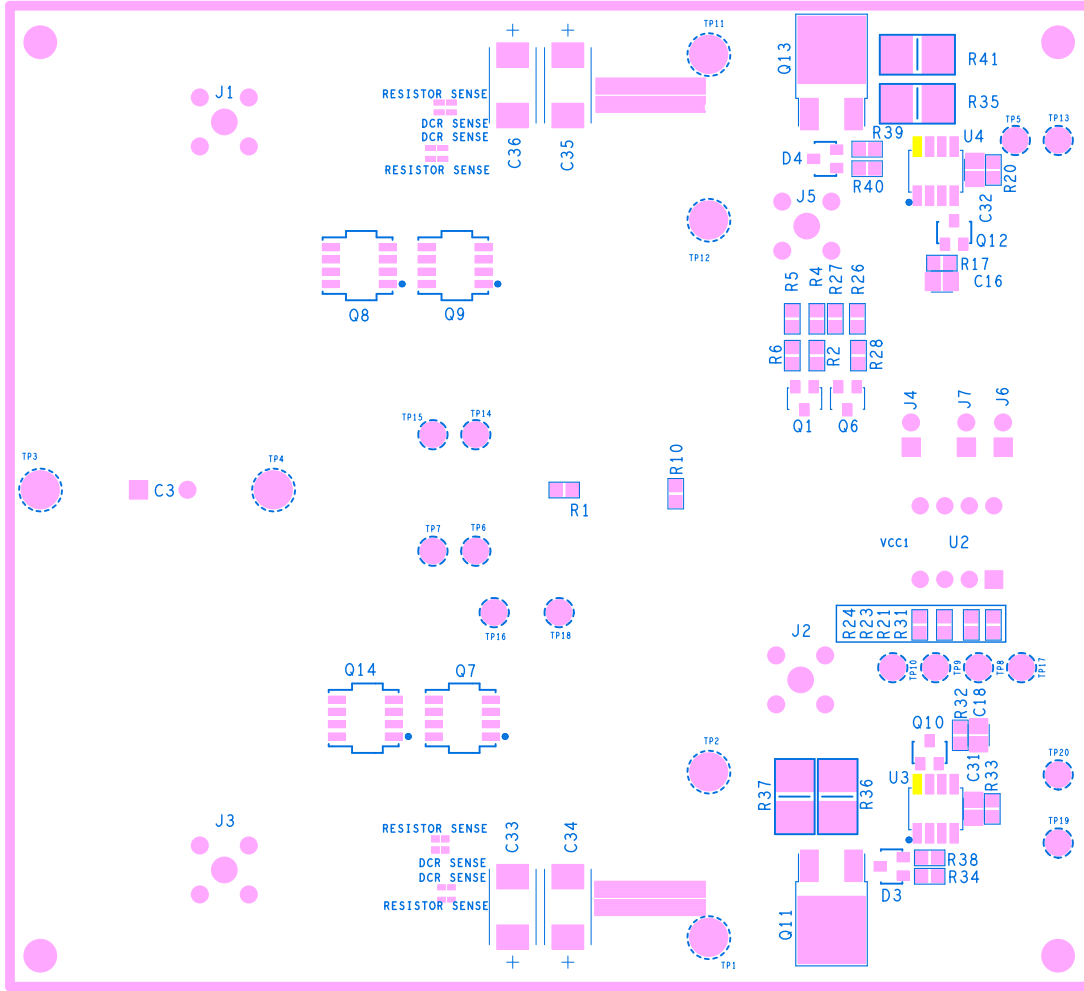

**FIGURE 4. BOTTOM SILKSCREEN**

**ISL6238xxxEVAL1Z Evaluation Board Layout** (Continued)

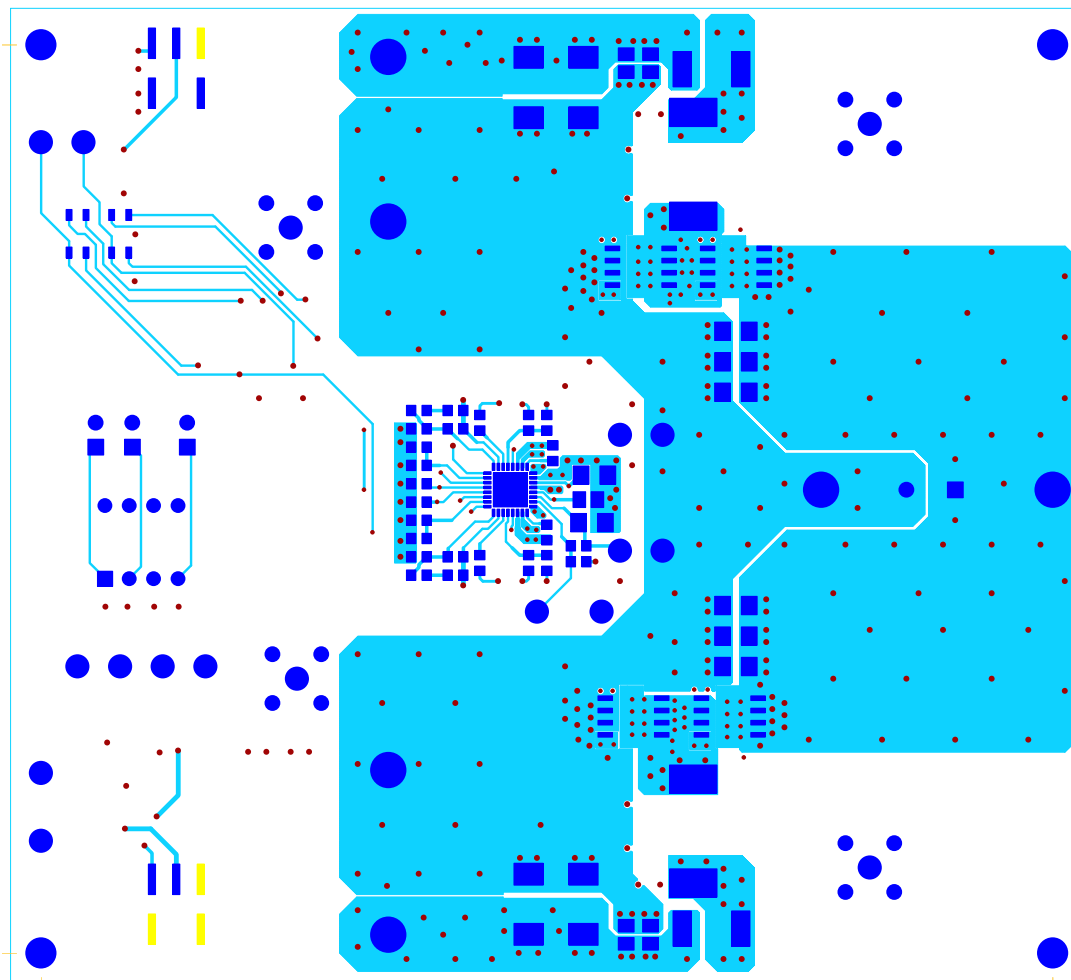

FIGURE 5. LAYER 1

**ISL6238xxxEVAL1Z Evaluation Board Layout** (Continued)

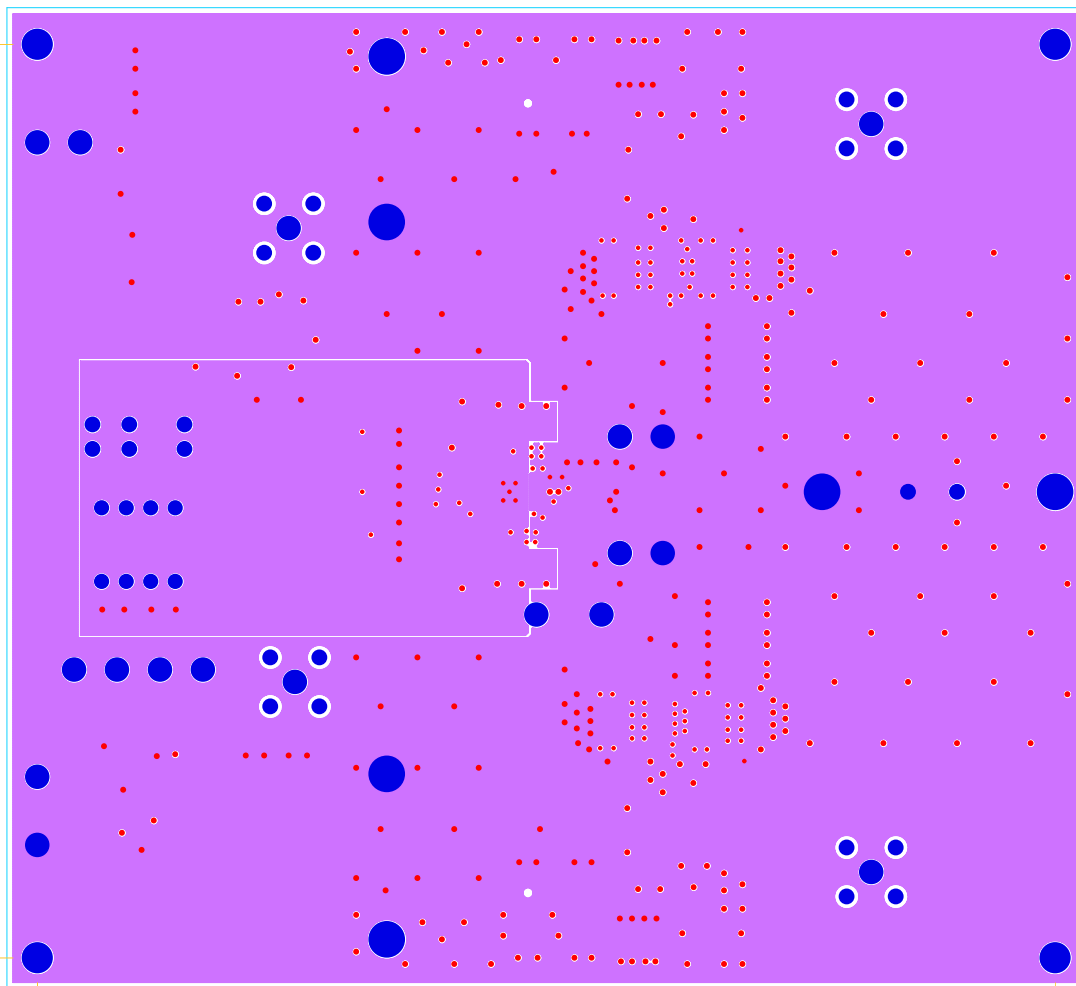

FIGURE 6. LAYER 2

**ISL6238xxxEVAL1Z Evaluation Board Layout** (Continued)

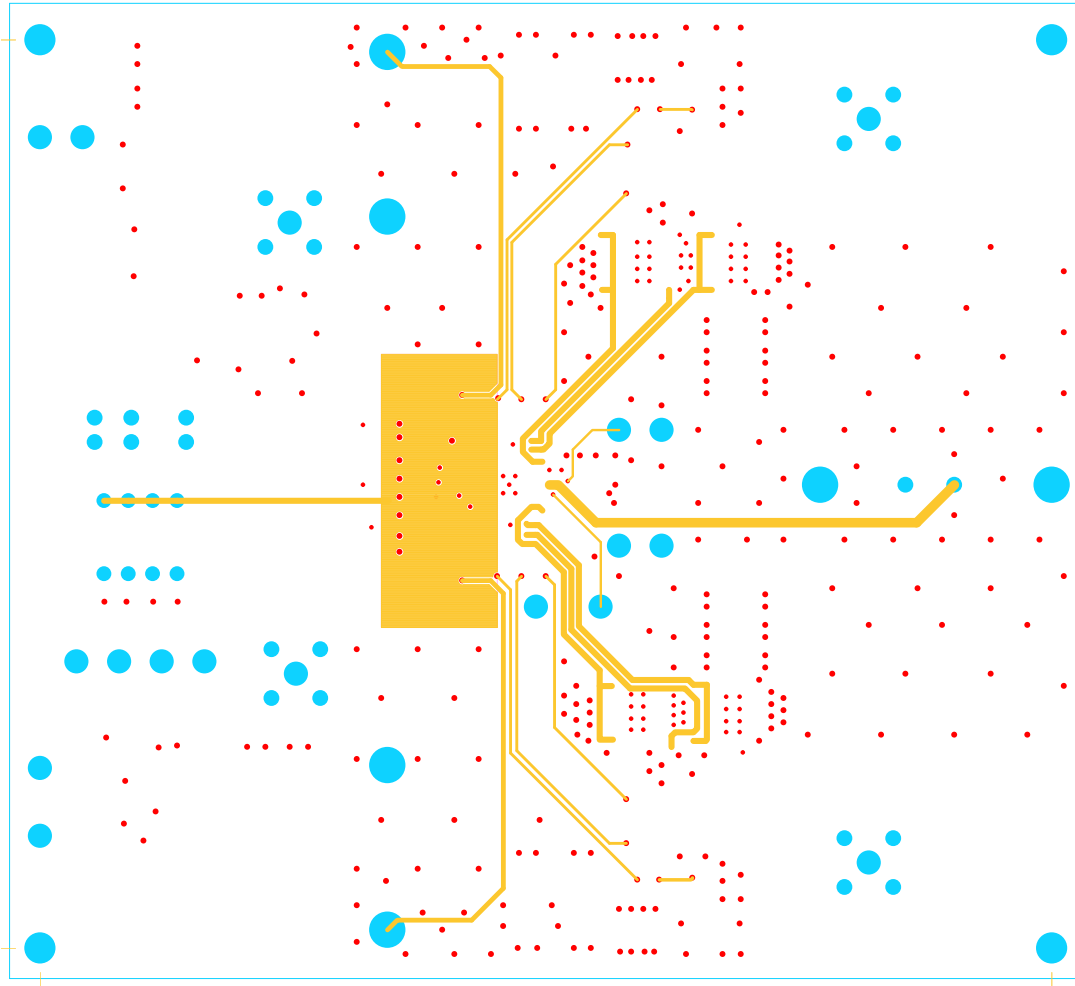

FIGURE 7. LAYER 3

**ISL6238xxxEVAL1Z Evaluation Board Layout** (Continued)

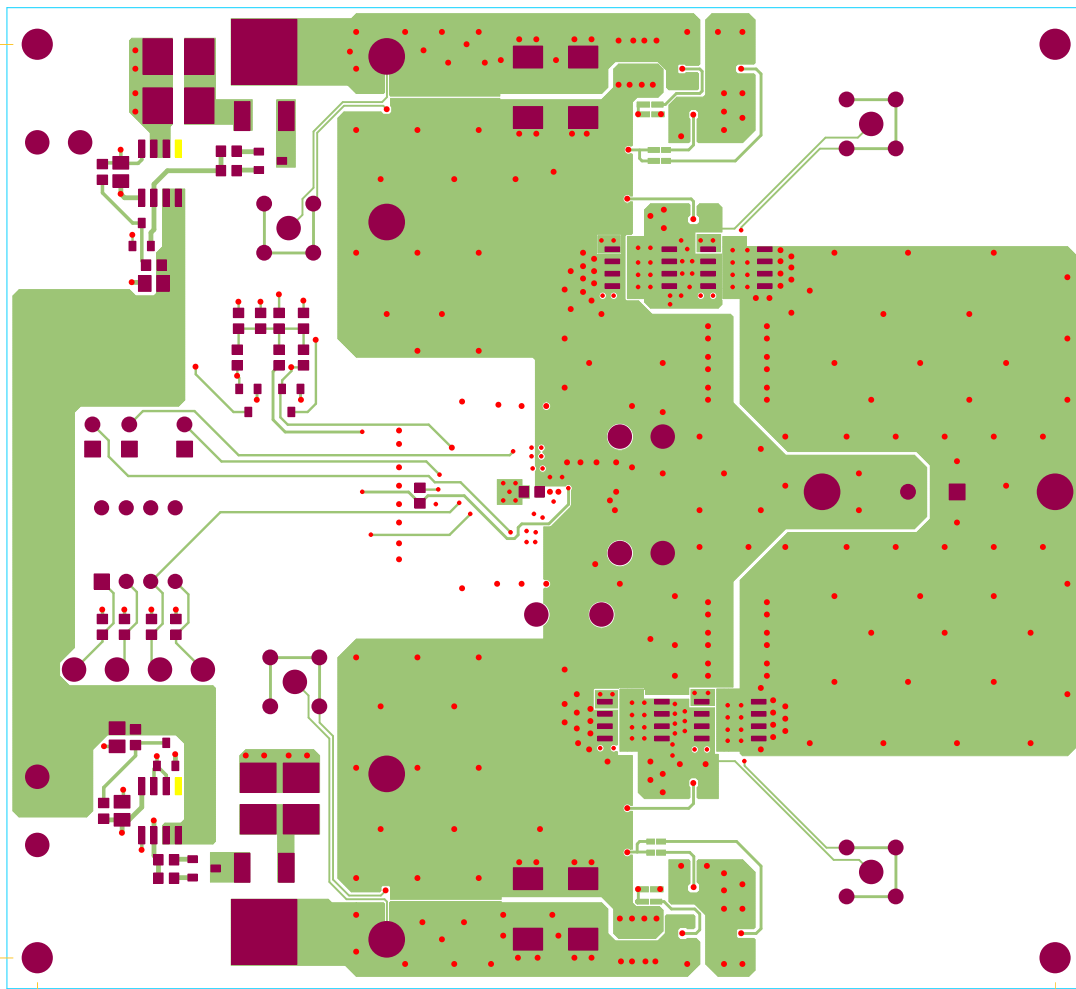

FIGURE 8. LAYER 4

## Notice

1. Descriptions of circuits, software and other related information in this document are provided only to illustrate the operation of semiconductor products and application examples. You are fully responsible for the incorporation or any other use of the circuits, software, and information in the design of your product or system. Renesas Electronics disclaims any and all liability for any losses and damages incurred by you or third parties arising from the use of these circuits, software, or information.
2. Renesas Electronics hereby expressly disclaims any warranties against and liability for infringement or any other claims involving patents, copyrights, or other intellectual property rights of third parties, by or arising from the use of Renesas Electronics products or technical information described in this document, including but not limited to, the product data, drawings, charts, programs, algorithms, and application examples.
3. No license, express, implied or otherwise, is granted hereby under any patents, copyrights or other intellectual property rights of Renesas Electronics or others.
4. You shall not alter, modify, copy, or reverse engineer any Renesas Electronics product, whether in whole or in part. Renesas Electronics disclaims any and all liability for any losses or damages incurred by you or third parties arising from such alteration, modification, copying or reverse engineering.
5. Renesas Electronics products are classified according to the following two quality grades: "Standard" and "High Quality". The intended applications for each Renesas Electronics product depends on the product's quality grade, as indicated below.  
"Standard": Computers; office equipment; communications equipment; test and measurement equipment; audio and visual equipment; home electronic appliances; machine tools; personal electronic equipment; industrial robots; etc.  
"High Quality": Transportation equipment (automobiles, trains, ships, etc.); traffic control (traffic lights); large-scale communication equipment; key financial terminal systems; safety control equipment; etc.  
Unless expressly designated as a high reliability product or a product for harsh environments in a Renesas Electronics data sheet or other Renesas Electronics document, Renesas Electronics products are not intended or authorized for use in products or systems that may pose a direct threat to human life or bodily injury (artificial life support devices or systems; surgical implantations; etc.), or may cause serious property damage (space system; undersea repeaters; nuclear power control systems; aircraft control systems; key plant systems; military equipment; etc.). Renesas Electronics disclaims any and all liability for any damages or losses incurred by you or any third parties arising from the use of any Renesas Electronics product that is inconsistent with any Renesas Electronics data sheet, user's manual or other Renesas Electronics document.
6. When using Renesas Electronics products, refer to the latest product information (data sheets, user's manuals, application notes, "General Notes for Handling and Using Semiconductor Devices" in the reliability handbook, etc.), and ensure that usage conditions are within the ranges specified by Renesas Electronics with respect to maximum ratings, operating power supply voltage range, heat dissipation characteristics, installation, etc. Renesas Electronics disclaims any and all liability for any malfunctions, failure or accident arising out of the use of Renesas Electronics products outside of such specified ranges.
7. Although Renesas Electronics endeavors to improve the quality and reliability of Renesas Electronics products, semiconductor products have specific characteristics, such as the occurrence of failure at a certain rate and malfunctions under certain use conditions. Unless designated as a high reliability product or a product for harsh environments in a Renesas Electronics data sheet or other Renesas Electronics document, Renesas Electronics products are not subject to radiation resistance design. You are responsible for implementing safety measures to guard against the possibility of bodily injury, injury or damage caused by fire, and/or danger to the public in the event of a failure or malfunction of Renesas Electronics products, such as safety design for hardware and software, including but not limited to redundancy, fire control and malfunction prevention, appropriate treatment for aging degradation or any other appropriate measures. Because the evaluation of microcomputer software alone is very difficult and impractical, you are responsible for evaluating the safety of the final products or systems manufactured by you.
8. Please contact a Renesas Electronics sales office for details as to environmental matters such as the environmental compatibility of each Renesas Electronics product. You are responsible for carefully and sufficiently investigating applicable laws and regulations that regulate the inclusion or use of controlled substances, including without limitation, the EU RoHS Directive, and using Renesas Electronics products in compliance with all these applicable laws and regulations. Renesas Electronics disclaims any and all liability for damages or losses occurring as a result of your noncompliance with applicable laws and regulations.
9. Renesas Electronics products and technologies shall not be used for or incorporated into any products or systems whose manufacture, use, or sale is prohibited under any applicable domestic or foreign laws or regulations. You shall comply with any applicable export control laws and regulations promulgated and administered by the governments of any countries asserting jurisdiction over the parties or transactions.
10. It is the responsibility of the buyer or distributor of Renesas Electronics products, or any other party who distributes, disposes of, or otherwise sells or transfers the product to a third party, to notify such third party in advance of the contents and conditions set forth in this document.
11. This document shall not be reprinted, reproduced or duplicated in any form, in whole or in part, without prior written consent of Renesas Electronics.
12. Please contact a Renesas Electronics sales office if you have any questions regarding the information contained in this document or Renesas Electronics products.  
(Note 1) "Renesas Electronics" as used in this document means Renesas Electronics Corporation and also includes its directly or indirectly controlled subsidiaries.  
(Note 2) "Renesas Electronics product(s)" means any product developed or manufactured by or for Renesas Electronics.

(Rev.4.0-1 November 2017)



### SALES OFFICES

Renesas Electronics Corporation

<http://www.renesas.com>

Refer to "<http://www.renesas.com/>" for the latest and detailed information.

**Renesas Electronics America Inc.**  
1001 Murphy Ranch Road, Milpitas, CA 95035, U.S.A.  
Tel: +1-408-432-8888, Fax: +1-408-434-5351

**Renesas Electronics Canada Limited**  
9251 Yonge Street, Suite 8309 Richmond Hill, Ontario Canada L4C 9T3  
Tel: +1-905-237-2004

**Renesas Electronics Europe Limited**  
Dukes Meadow, Millboard Road, Bourne End, Buckinghamshire, SL8 5FH, U.K  
Tel: +44-1628-651-700, Fax: +44-1628-651-804

**Renesas Electronics Europe GmbH**  
Arcadiastrasse 10, 40472 Düsseldorf, Germany  
Tel: +49-211-6503-0, Fax: +49-211-6503-1327

**Renesas Electronics (China) Co., Ltd.**  
Room 1709 Quantum Plaza, No.27 ZhichunLu, Haidian District, Beijing, 100191 P. R. China  
Tel: +86-10-8235-1155, Fax: +86-10-8235-7679

**Renesas Electronics (Shanghai) Co., Ltd.**  
Unit 301, Tower A, Central Towers, 555 Langao Road, Putuo District, Shanghai, 200333 P. R. China  
Tel: +86-21-2226-0888, Fax: +86-21-2226-0999

**Renesas Electronics Hong Kong Limited**  
Unit 1601-1611, 16/F., Tower 2, Grand Century Place, 193 Prince Edward Road West, Mongkok, Kowloon, Hong Kong  
Tel: +852-2265-6688, Fax: +852-2886-9022

**Renesas Electronics Taiwan Co., Ltd.**  
13F, No. 363, Fu Shing North Road, Taipei 10543, Taiwan  
Tel: +886-2-8175-9600, Fax: +886-2-8175-9670

**Renesas Electronics Singapore Pte. Ltd.**  
80 Bendemeer Road, Unit #06-02 Hyflux Innovation Centre, Singapore 339949  
Tel: +65-6213-0200, Fax: +65-6213-0300

**Renesas Electronics Malaysia Sdn.Bhd.**  
Unit 1207, Block B, Menara Amcorp, Amcorp Trade Centre, No. 18, Jln Persiaran Barat, 46050 Petaling Jaya, Selangor Darul Ehsan, Malaysia  
Tel: +60-3-7955-9390, Fax: +60-3-7955-9510

**Renesas Electronics India Pvt. Ltd.**  
No.777C, 100 Feet Road, HAL 2nd Stage, Indiranagar, Bangalore 560 038, India  
Tel: +91-80-67208700, Fax: +91-80-67208777

**Renesas Electronics Korea Co., Ltd.**  
17F, KAMCO Yangjae Tower, 262, Gangnam-daero, Gangnam-gu, Seoul, 06265 Korea  
Tel: +82-2-558-3737, Fax: +82-2-558-5338

Компания «Океан Электроники» предлагает заключение долгосрочных отношений при поставках импортных электронных компонентов на взаимовыгодных условиях!

Наши преимущества:

- Поставка оригинальных импортных электронных компонентов напрямую с производств Америки, Европы и Азии, а так же с крупнейших складов мира;
- Широкая линейка поставок активных и пассивных импортных электронных компонентов (более 30 млн. наименований);
- Поставка сложных, дефицитных, либо снятых с производства позиций;
- Оперативные сроки поставки под заказ (от 5 рабочих дней);
- Экспресс доставка в любую точку России;
- Помощь Конструкторского Отдела и консультации квалифицированных инженеров;
- Техническая поддержка проекта, помощь в подборе аналогов, поставка прототипов;
- Поставка электронных компонентов под контролем ВП;
- Система менеджмента качества сертифицирована по Международному стандарту ISO 9001;
- При необходимости вся продукция военного и аэрокосмического назначения проходит испытания и сертификацию в лаборатории (по согласованию с заказчиком);
- Поставка специализированных компонентов военного и аэрокосмического уровня качества (Xilinx, Altera, Analog Devices, Intersil, Interpoint, Microsemi, Actel, Aeroflex, Peregrine, VPT, Syfer, Eurofarad, Texas Instruments, MS Kennedy, Miteq, Cobham, E2V, MA-COM, Hittite, Mini-Circuits, General Dynamics и др.);

Компания «Океан Электроники» является официальным дистрибьютором и эксклюзивным представителем в России одного из крупнейших производителей разъемов военного и аэрокосмического назначения «JONHON», а так же официальным дистрибьютором и эксклюзивным представителем в России производителя высокотехнологичных и надежных решений для передачи СВЧ сигналов «FORSTAR».



## JONHON

«JONHON» (основан в 1970 г.)

Разъемы специального, военного и аэрокосмического назначения:

(Применяются в военной, авиационной, аэрокосмической, морской, железнодорожной, горно- и нефтедобывающей отраслях промышленности)

«FORSTAR» (основан в 1998 г.)

ВЧ соединители, коаксиальные кабели,  
кабельные сборки и микроволновые компоненты:

(Применяются в телекоммуникациях гражданского и специального назначения, в средствах связи, РЛС, а так же военной, авиационной и аэрокосмической отраслях промышленности).



Телефон: 8 (812) 309-75-97 (многоканальный)

Факс: 8 (812) 320-03-32

Электронная почта: [ocean@oceanchips.ru](mailto:ocean@oceanchips.ru)

Web: <http://oceanchips.ru/>

Адрес: 198099, г. Санкт-Петербург, ул. Калинина, д. 2, корп. 4, лит. А