

Multi-Channel Audio Hub CODEC for Smartphones

DESCRIPTION

The WM8958^[1] is a highly integrated ultra-low power hi-fi CODEC designed for smartphones and other portable devices rich in multimedia features.

An integrated stereo Class D/AB speaker driver and Class W headphone driver minimize power consumption during audio playback.

The device requires only two voltage supplies, with all other internal supply rails generated from integrated LDOs.

Stereo full duplex asynchronous sample rate conversion and multi-channel digital mixing combined with powerful analogue mixing allow the device to support a huge range of different architectures and use cases.

A multiband compressor and programmable parametric EQ provide volume maximisation and speaker compensation in the digital playback paths. The dynamic range controller can be used in record or playback paths for maintaining a constant signal level, maximizing loudness and protecting speakers against overloading and clipping.

A smart digital microphone interface provides power regulation, a low jitter clock output and decimation filters for up to four digital microphones. Microphone activity detection with interrupt is available. Impedance sensing and measurement is provided for external accessory / push-button detection.

Fully differential internal architecture and on-chip RF noise filters ensure a very high degree of noise immunity. Active ground loop noise rejection and DC offset correction help prevent pop noise and suppress ground noise on the headphone outputs.

FEATURES

- 24-bit 4-channel hi-fi DAC and 2-channel hi-fi ADC
- 100dB SNR during DAC playback ('A' weighted)
- Smart MIC interface
 - Power, clocking and data input for up to four digital MICs
 - High performance analogue MIC interface
 - MIC activity detect & interrupt allows processor to sleep
 - Impedance sensing for accessory / push-button detection
- 2W stereo (2 x 2W) Class D/AB speaker driver
- Capless Class W headphone drivers
 - Integrated charge pump
 - 5.3mW total power for DAC playback to headphones
- 4 Line outputs (single-ended or differential)
- BTL Earpiece driver
- Digital audio interfaces for multi-processor architecture
 - Asynchronous stereo duplex sample rate conversion
 - Powerful mixing and digital loopback functions
- ReTune™ Mobile 5-band, 6-channel parametric EQ
- Multiband compressor and dynamic range controller
- Dual FLL provides all necessary clocks
 - Self-clocking modes allow processor to sleep
 - All standard sample rates from 8kHz to 96kHz
- Active noise reduction circuits
 - DC offset correction removes pops and clicks
 - Ground loop noise cancellation
- Integrated LDO regulators
- 72-ball W-CSP package (4.516 x 4.258 x 0.698mm)

APPLICATIONS

- Smartphones and music phones
- Portable navigation
- Tablets
- eBooks
- Portable Media Players

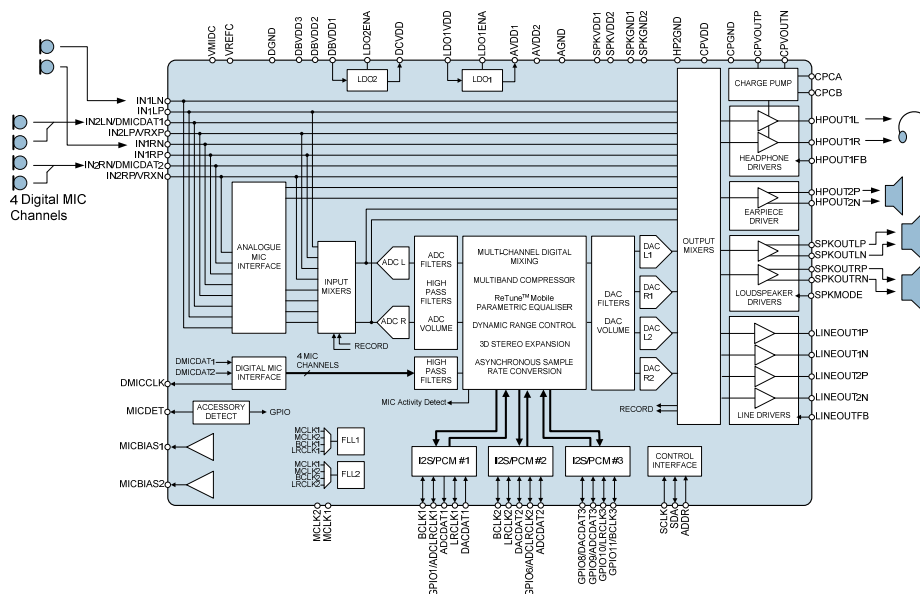

TABLE OF CONTENTS

DESCRIPTION	1
FEATURES	1
APPLICATIONS	1
TABLE OF CONTENTS	2
BLOCK DIAGRAM	7
PIN CONFIGURATION	8
ORDERING INFORMATION	8
PIN DESCRIPTION	9
ABSOLUTE MAXIMUM RATINGS	12
RECOMMENDED OPERATING CONDITIONS	13
THERMAL PERFORMANCE	14
ELECTRICAL CHARACTERISTICS	15
INPUT SIGNAL LEVEL	15
INPUT PIN RESISTANCE.....	16
PROGRAMMABLE GAINS.....	18
OUTPUT DRIVER CHARACTERISTICS	19
ADC INPUT PATH PERFORMANCE.....	20
DAC OUTPUT PATH PERFORMANCE.....	21
BYPASS PATH PERFORMANCE.....	24
MULTI-PATH CROSSTALK	26
DIGITAL INPUT / OUTPUT	28
DIGITAL FILTER CHARACTERISTICS	28
MICROPHONE BIAS CHARACTERISTICS.....	29
MISCELLANEOUS CHARACTERISTICS	30
TERMINOLOGY	31
TYPICAL PERFORMANCE	32
TYPICAL POWER CONSUMPTION	32
TYPICAL SIGNAL LATENCY.....	33
SPEAKER DRIVER PERFORMANCE	34
SIGNAL TIMING REQUIREMENTS	35
SYSTEM CLOCKS & FREQUENCY LOCKED LOOP (FLL).....	35
AUDIO INTERFACE TIMING	36
DIGITAL MICROPHONE (DMIC) INTERFACE TIMING.....	36
DIGITAL AUDIO INTERFACE - MASTER MODE	37
DIGITAL AUDIO INTERFACE - SLAVE MODE.....	38
DIGITAL AUDIO INTERFACE - TDM MODE	39
CONTROL INTERFACE TIMING	40
DEVICE DESCRIPTION	41
INTRODUCTION.....	41
ANALOGUE INPUT SIGNAL PATH	43
MICROPHONE INPUTS	44
MICROPHONE BIAS CONTROL	44
MICROPHONE ACCESSORY DETECT	46
LINE AND VOICE CODEC INPUTS	46
INPUT PGA ENABLE	47
INPUT PGA CONFIGURATION	48
INPUT PGA VOLUME CONTROL.....	49
INPUT MIXER ENABLE.....	52
INPUT MIXER CONFIGURATION AND VOLUME CONTROL	52

DIGITAL MICROPHONE INTERFACE	56
DIGITAL PULL-UP AND PULL-DOWN	59
ANALOGUE TO DIGITAL CONVERTER (ADC)	59
ADC CLOCKING CONTROL	60
DIGITAL CORE ARCHITECTURE	61
DIGITAL MIXING	63
AUDIO INTERFACE 1 (AIF1) OUTPUT MIXING	64
DIGITAL SIDETONE MIXING	65
DIGITAL SIDETONE VOLUME AND FILTER CONTROL	65
DAC OUTPUT DIGITAL MIXING	67
AUDIO INTERFACE 2 (AIF2) DIGITAL MIXING	68
ULTRASONIC (4FS) AIF OUTPUT MODE	69
MULTIBAND COMPRESSOR (MBC)	70
RMS LIMITER	71
MBC CLOCKING CONTROL	71
MBC CONTROL SEQUENCES	72
DYNAMIC RANGE CONTROL (DRC)	74
DRC COMPRESSION / EXPANSION / LIMITING	75
GAIN LIMITS	77
DYNAMIC CHARACTERISTICS	77
ANTI-CLIP CONTROL	77
QUICK RELEASE CONTROL	78
SIGNAL ACTIVITY DETECT	78
DRC REGISTER CONTROLS	78
RETUNE™ MOBILE PARAMETRIC EQUALIZER (EQ)	88
DEFAULT MODE (5-BAND PARAMETRIC EQ)	89
RETUNE™ MOBILE MODE	91
EQ FILTER CHARACTERISTICS	92
3D STEREO EXPANSION	93
DIGITAL VOLUME AND FILTER CONTROL	94
AIF1 - OUTPUT PATH VOLUME CONTROL	94
AIF1 - OUTPUT PATH HIGH PASS FILTER	96
AIF1 - INPUT PATH VOLUME CONTROL	98
AIF1 - INPUT PATH SOFT MUTE CONTROL	101
AIF1 - INPUT PATH NOISE GATE CONTROL	102
AIF1 - INPUT PATH MONO MIX CONTROL	103
AIF2 - OUTPUT PATH VOLUME CONTROL	103
AIF2 - OUTPUT PATH HIGH PASS FILTER	104
AIF2 - INPUT PATH VOLUME CONTROL	105
AIF2 - INPUT PATH SOFT MUTE CONTROL	106
AIF2 - INPUT PATH NOISE GATE CONTROL	106
AIF2 - INPUT PATH MONO MIX CONTROL	107
DIGITAL TO ANALOGUE CONVERTER (DAC)	108
DAC CLOCKING CONTROL	108
DAC DIGITAL VOLUME	110
DAC SOFT MUTE AND SOFT UN-MUTE	113
ANALOGUE OUTPUT SIGNAL PATH	115
OUTPUT SIGNAL PATHS ENABLE	116
HEADPHONE SIGNAL PATHS ENABLE	118
OUTPUT MIXER CONTROL	120
SPEAKER MIXER CONTROL	124
OUTPUT SIGNAL PATH VOLUME CONTROL	127
SPEAKER BOOST MIXER	131
EARPIECE DRIVER MIXER	131
LINE OUTPUT MIXERS	133

CHARGE PUMP	137
DC SERVO	139
DC SERVO ENABLE AND START-UP	139
DC SERVO ACTIVE MODES	141
GPIO / INTERRUPT OUTPUTS FROM DC SERVO	142
ANALOGUE OUTPUTS	143
SPEAKER OUTPUT CONFIGURATIONS	143
HEADPHONE OUTPUT CONFIGURATIONS	146
EARPIECE DRIVER OUTPUT CONFIGURATIONS	147
LINE OUTPUT CONFIGURATIONS	147
EXTERNAL ACCESSORY DETECTION	150
ACCESSORY DETECTION WITH LOW FREQUENCY SYSCLK	154
GENERAL PURPOSE INPUT/OUTPUT	155
GPIO CONTROL	155
GPIO FUNCTION SELECT	156
BUTTON DETECT (GPIO INPUT)	158
LOGIC '1' AND LOGIC '0' OUTPUT (GPIO OUTPUT)	158
INTERRUPT (IRQ) STATUS OUTPUT	158
OVER-TEMPERATURE DETECTION	158
MICROPHONE ACCESSORY STATUS DETECTION	159
FREQUENCY LOCKED LOOP (FLL) LOCK STATUS OUTPUT	159
SAMPLE RATE CONVERTER (SRC) LOCK STATUS OUTPUT	159
DYNAMIC RANGE CONTROL (DRC) SIGNAL ACTIVITY DETECTION	160
CONTROL WRITE SEQUENCER STATUS DETECTION	162
DIGITAL CORE FIFO ERROR STATUS DETECTION	162
OPCLK CLOCK OUTPUT	162
FLL CLOCK OUTPUT	163
INTERRUPTS	164
DIGITAL AUDIO INTERFACE	169
MASTER AND SLAVE MODE OPERATION	170
OPERATION WITH TDM	170
AUDIO DATA FORMATS (NORMAL MODE)	171
AUDIO DATA FORMATS (TDM MODE)	174
DIGITAL AUDIO INTERFACE CONTROL	176
AIF1 - MASTER / SLAVE AND TRI-STATE CONTROL	176
AIF1 - SIGNAL PATH ENABLE	177
AIF1 - BCLK AND LRCLK CONTROL	177
AIF1 - DIGITAL AUDIO DATA CONTROL	180
AIF1 - MONO MODE	181
AIF1 - COMPANDING	182
AIF1 - LOOPBACK	184
AIF1 - DIGITAL PULL-UP AND PULL-DOWN	184
AIF2 - MASTER / SLAVE AND TRI-STATE CONTROL	185
AIF2 - SIGNAL PATH ENABLE	186
AIF2 - BCLK AND LRCLK CONTROL	186
AIF2 - DIGITAL AUDIO DATA CONTROL	189
AIF2 - MONO MODE	191
AIF2 - COMPANDING	191
AIF2 - LOOPBACK	191
AIF2 - DIGITAL PULL-UP AND PULL-DOWN	192
AIF3 - SIGNAL PATH CONFIGURATION AND TRI-STATE CONTROL	193
AIF3 - BCLK AND LRCLK CONTROL	195
AIF3 - DIGITAL AUDIO DATA CONTROL	196
AIF3 - COMPANDING	197
AIF3 - LOOPBACK	197

CLOCKING AND SAMPLE RATES	198
AIF1CLK ENABLE	199
AIF1 CLOCKING CONFIGURATION	200
AIF2CLK ENABLE	202
AIF2 CLOCKING CONFIGURATION	202
MISCELLANEOUS CLOCK CONTROLS	204
BCLK AND LRCLK CONTROL	207
CONTROL INTERFACE CLOCKING	209
FREQUENCY LOCKED LOOP (FLL)	209
FREE-RUNNING FLL CLOCK	216
GPIO OUTPUTS FROM FLL	217
EXAMPLE FLL CALCULATION	218
EXAMPLE FLL SETTINGS	219
SAMPLE RATE CONVERSION	220
SAMPLE RATE CONVERTER 1 (SRC1)	220
SAMPLE RATE CONVERTER 2 (SRC2)	220
SAMPLE RATE CONVERTER RESTRICTIONS	220
SAMPLE RATE CONVERTER CONFIGURATION ERROR INDICATION	222
CONTROL INTERFACE	223
CONTROL WRITE SEQUENCER	226
INITIATING A SEQUENCE.....	226
PROGRAMMING A SEQUENCE	227
DEFAULT SEQUENCES	229
POP SUPPRESSION CONTROL	236
DISABLED LINE OUTPUT CONTROL	236
LINE OUTPUT DISCHARGE CONTROL	237
VMID REFERENCE DISCHARGE CONTROL	237
INPUT VMID CLAMPS	237
LDO REGULATORS	238
REFERENCE VOLTAGES AND MASTER BIAS	240
POWER MANAGEMENT	242
THERMAL SHUTDOWN	247
POWER ON RESET	248
QUICK START-UP AND SHUTDOWN	250
SOFTWARE RESET AND DEVICE ID	251
REGISTER MAP	252
REGISTER BITS BY ADDRESS	264
APPLICATIONS INFORMATION	356
RECOMMENDED EXTERNAL COMPONENTS	356
AUDIO INPUT PATHS.....	356
HEADPHONE OUTPUT PATH.....	358
EARPIECE DRIVER OUTPUT PATH.....	358
LINE OUTPUT PATHS	358
POWER SUPPLY DECOUPLING	359
CHARGE PUMP COMPONENTS	360
MICROPHONE BIAS CIRCUIT	360
EXTERNAL ACCESSORY DETECTION COMPONENTS	362
CLASS D SPEAKER CONNECTIONS	363
RECOMMENDED EXTERNAL COMPONENTS DIAGRAM	364
DIGITAL AUDIO INTERFACE CLOCKING CONFIGURATIONS	366
PCB LAYOUT CONSIDERATIONS	369
CLASS D LOUDSPEAKER CONNECTION	369

PACKAGE DIMENSIONS	370
IMPORTANT NOTICE	371
ADDRESS:	371
REVISION HISTORY	372

BLOCK DIAGRAM

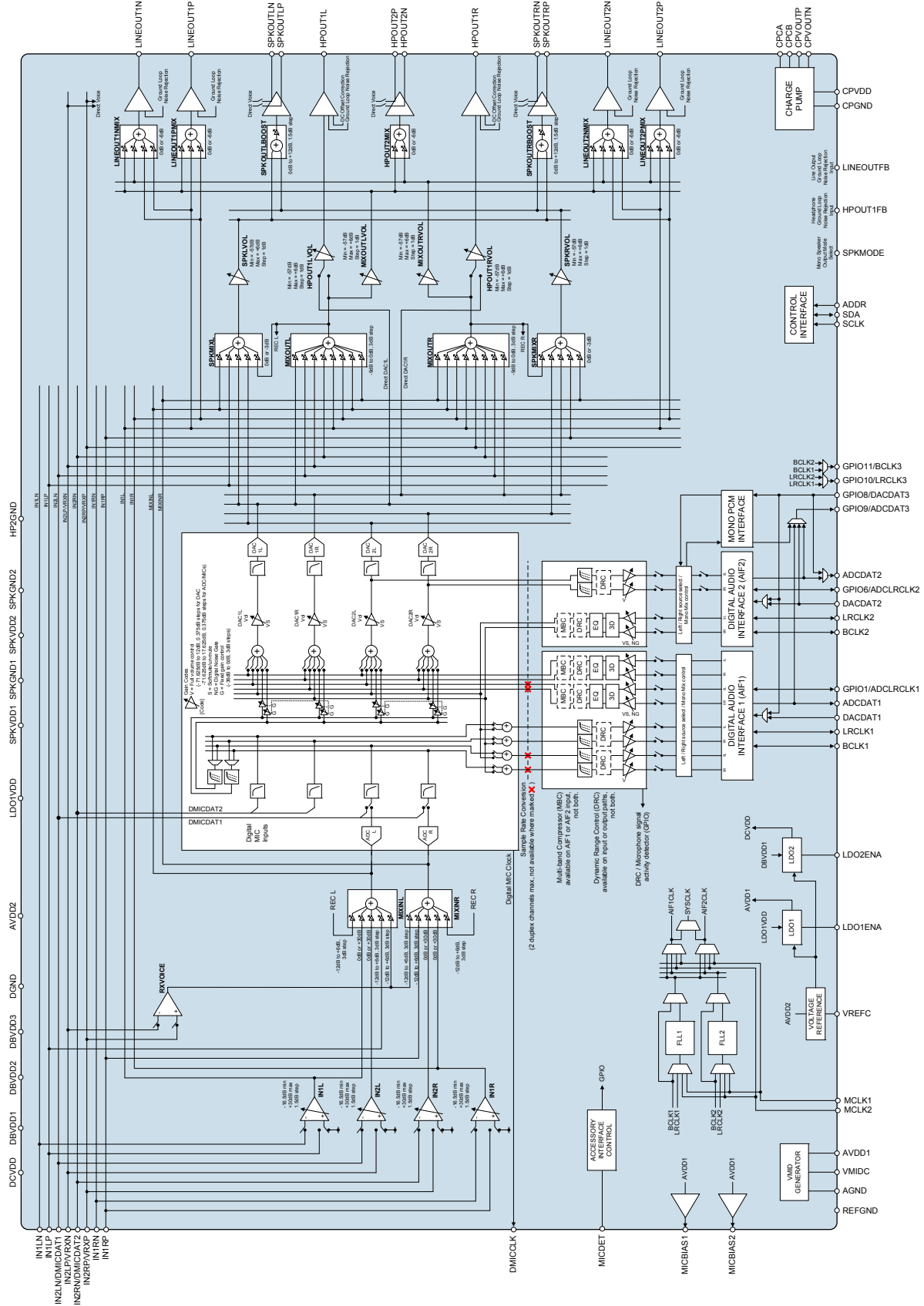

PIN CONFIGURATION

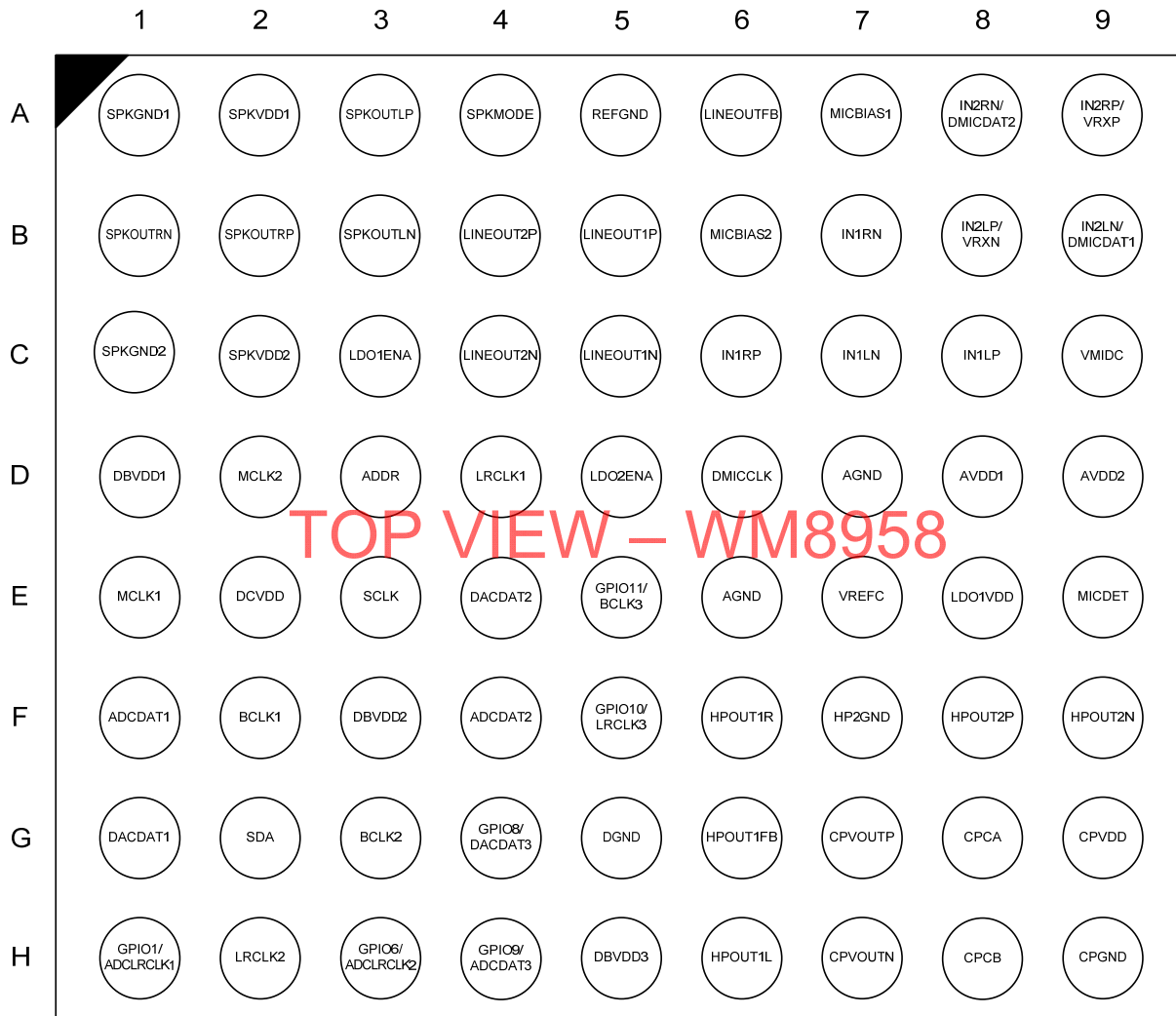

TOP VIEW – WM8958

ORDERING INFORMATION

ORDER CODE	TEMPERATURE RANGE	PACKAGE	MOISTURE SENSITIVITY LEVEL	PEAK SOLDERING TEMPERATURE
WM8958ECS/R	-40°C to +85°C	72-ball W-CSP (Pb-free, Tape and reel)	MSL1	260°C

Note:

Reel quantity = 5000

PIN DESCRIPTION

A description of each pin on the WM8958 is provided below.

Note that a table detailing the associated power domain for every input and output pin is provided on the following page.

Note that, where multiple pins share a common name, these pins should be tied together on the PCB.

PIN NO	NAME	TYPE	DESCRIPTION
F1	ADCDAT1	Digital Output	Audio interface 1 ADC digital audio data
F4	ADCDAT2	Digital Output	Audio interface 2 ADC digital audio data
D3	ADDR	Digital Input	2-wire (I2C) address select
D7, E6	AGND	Supply	Analogue ground (Return path for AVDD1, AVDD2 and LDO1VDD)
D8	AVDD1	Supply / Analogue Output	Analogue core supply / LDO1 Output
D9	AVDD2	Supply	Bandgap reference, analogue Class D and FLL supply
F2	BCLK1	Digital Input / Output	Audio interface 1 bit clock
G3	BCLK2	Digital Input / Output	Audio interface 2 bit clock
G8	CPCA	Analogue Output	Charge pump fly-back capacitor pin
H8	CPCB	Analogue Output	Charge pump fly-back capacitor pin
H9	CPGND	Supply	Charge pump ground (Return path for CPVDD)
G9	CPVDD	Supply	Charge pump supply
H7	CPVOUTN	Analogue Output	Charge pump negative supply decoupling pin (HPOUT1L, HPOUT1R)
G7	CPVOUTP	Analogue Output	Charge pump positive supply decoupling pin (HPOUT1L, HPOUT1R)
G1	DACDAT1	Digital Input	Audio interface 1 DAC digital audio data
E4	DACDAT2	Digital Input	Audio interface 2 DAC digital audio data
D1	DBVDD1	Supply	Digital buffer (I/O) supply (core functions and Audio Interface 1)
F3	DBVDD2	Supply	Digital buffer (I/O) supply (for Audio Interface 2)
H5	DBVDD3	Supply	Digital buffer (I/O) supply (for Audio Interface 3)
E2	DCVDD	Supply / Analogue Output	Digital core supply / LDO2 output
G5	DGND	Supply	Digital ground (Return path for DCVDD, DBVDD1, DBVDD2, DBVDD3)
D6	DMICCLK	Digital Output	Digital MIC clock output
H1	GPIO1/ ADCLRCLK1	Digital Input / Output	General Purpose pin GPIO 1 / Audio interface 1 ADC left / right clock
F5	GPIO10/ LRCLK3	Digital Input / Output	General Purpose pin GPIO 10 / Audio interface 3 left / right clock
E5	GPIO11/ BCLK3	Digital Input / Output	General Purpose pin GPIO 11 / Audio interface 3 bit clock
H3	GPIO6/ ADCLRCLK2	Digital Input / Output	General Purpose pin GPIO 6 / Audio interface 2 ADC left / right clock
G4	GPIO8/ DACDAT3	Digital Input / Output	General Purpose pin GPIO 8 / Audio interface 3 DAC digital audio data
H4	GPIO9/ ADCDAT3	Digital Input / Output	General Purpose pin GPIO 9 / Audio interface 3 ADC digital audio data
F7	HP2GND	Supply	Analogue ground
G6	HPOUT1FB	Analogue Input	HPOUT1L and HPOUT1R ground loop noise rejection feedback
H6	HPOUT1L	Analogue Output	Left headphone output
F6	HPOUT1R	Analogue Output	Right headphone output
F9	HPOUT2N	Analogue Output	Earpiece speaker inverted output
F8	HPOUT2P	Analogue Output	Earpiece speaker non-inverted output
C7	IN1LN	Analogue Input	Left channel single-ended MIC input / Left channel negative differential MIC input
C8	IN1LP	Analogue Input	Left channel line input / Left channel positive differential MIC input

PIN NO	NAME	TYPE	DESCRIPTION
B7	IN1RN	Analogue Input	Right channel single-ended MIC input / Right channel negative differential MIC input
C6	IN1RP	Analogue Input	Right channel line input / Right channel positive differential MIC input
B9	IN2LN/ DMICDAT1	Analogue Input / Digital Input	Left channel line input / Left channel negative differential MIC input / Digital MIC data input 1
B8	IN2LP/VRXN	Analogue Input	Left channel line input / Left channel positive differential MIC input / Mono differential negative input (RXVOICE -)
A8	IN2RN/ DMICDAT2	Analogue Input / Digital Input	Right channel line input / Right channel negative differential MIC input / Digital MIC data input 2
A9	IN2RP/VRXP	Analogue Input	Left channel line input / Left channel positive differential MIC input / Mono differential positive input (RXVOICE +)
C3	LDO1ENA	Digital Input	Enable pin for LDO1
E8	LDO1VDD	Supply	Supply for LDO1
D5	LDO2ENA	Digital Input	Enable pin for LDO2
C5	LINEOUT1N	Analogue Output	Negative mono line output / Positive left or right line output
B5	LINEOUT1P	Analogue Output	Positive mono line output / Positive left line output
C4	LINEOUT2N	Analogue Output	Negative mono line output / Positive left or right line output
B4	LINEOUT2P	Analogue Output	Positive mono line output / Positive left line output
A6	LINEOUTFB	Analogue Input	Line output ground loop noise rejection feedback
D4	LRCLK1	Digital Input / Output	Audio interface 1 left / right clock
H2	LRCLK2	Digital Input / Output	Audio interface 2 left / right clock
E1	MCLK1	Digital Input	Master clock 1
D2	MCLK2	Digital Input	Master clock 2
A7	MICBIAS1	Analogue Output	Microphone bias 1
B6	MICBIAS2	Analogue Output	Microphone bias 2
E9	MICDET	Analogue Input	Microphone & accessory sense input
A5	REFGND	Supply	Analogue ground
E3	SCLK	Digital Input	Control interface clock input
G2	SDA	Digital Input / Output	Control interface data input and output / acknowledge output
A1	SPKGND1	Supply	Ground for speaker driver (Return path for SPKVDD1)
C1	SPKGND2	Supply	Ground for speaker driver (Return path for SPKVDD2)
A4	SPKMODE	Digital Input	Mono / Stereo speaker mode select
B3	SPKOUTLN	Analogue Output	Left speaker negative output
A3	SPKOUTLP	Analogue Output	Left speaker positive output
B1	SPKOUTRN	Analogue Output	Right speaker negative output
B2	SPKOUTRP	Analogue Output	Right speaker positive output
A2	SPKVDD1	Supply	Supply for speaker driver 1 (Left channel)
C2	SPKVDD2	Supply	Supply for speaker driver 2 (Right channel)
C9	VMIDC	Analogue Output	Midrail voltage decoupling capacitor
E7	VREFC	Analogue Output	Bandgap reference decoupling capacitor

The following table identifies the power domain and ground reference associated with each of the input / output pins.

PIN NO	NAME	POWER DOMAIN	GROUND DOMAIN
F1	ADCDAT1	DBVDD1	DGND
F4	ADCDAT2	DBVDD2	DGND
D3	ADDR	DBVDD1	DGND
F2	BCLK1	DBVDD1	DGND
G3	BCLK2	DBVDD2	DGND
G1	DACDAT1	DBVDD1	DGND
E4	DACDAT2	DBVDD2	DGND
D6	DMICCLK	MICBIAS1	AGND
H1	GPIO1/ADCLRCLK1	DBVDD1	DGND
H3	GPIO6/ADCLRCLK2	DBVDD2	DGND
G4	GPIO8/DACDAT3	DBVDD3	DGND
H4	GPIO9/ADCDAT3	DBVDD3	DGND
F5	GPIO10/LRCLK3	DBVDD3	DGND
E5	GPIO11/BCLK3	DBVDD3	DGND
H6	HPOUT1L	CPVOUTP, CPVOUTN	CPGND
F6	HPOUT1R	CPVOUTP, CPVOUTN	CPGND
F9	HPOUT2N	AVDD1	HP2GND
F8	HPOUT2P	AVDD1	HP2GND
C7	IN1LN	AVDD1	AGND
C8	IN1LP	AVDD1	AGND
B7	IN1RN	AVDD1	AGND
C6	IN1RP	AVDD1	AGND
B9	IN2LN/DMICDAT1	AVDD1 (IN2LN) or MICBIAS1 (DMICDAT1)	AGND
B8	IN2LP/VRXN	AVDD1	AGND
A8	IN2RN/DMICDAT2	AVDD1 (IN2RN) or MICBIAS1 (DMICDAT2)	AGND (IN2RN) or DGND (DMICDAT2)
A9	IN2RP/VRXP	AVDD1	AGND
C3	LDO1ENA	DBVDD1	DGND
D5	LDO2ENA	DBVDD1	DGND
C5	LINEOUT1N	AVDD1	AGND
B5	LINEOUT1P	AVDD1	AGND
C4	LINEOUT2N	AVDD1	AGND
B4	LINEOUT2P	AVDD1	AGND
D4	LRCLK1	DBVDD1	DGND
H2	LRCLK2	DBVDD2	DGND
E1	MCLK1	DBVDD1	DGND
D2	MCLK2	DBVDD1	DGND
E9	MICDET	MICBIAS2	AGND
E3	SCLK	DBVDD1	DGND
G2	SDA	DBVDD1	DGND
A4	SPKMODE	DBVDD1	DGND
B3	SPKOUTLN	SPKVDD1	SPKGND1
A3	SPKOUTLP	SPKVDD1	SPKGND1
B1	SPKOUTRN	SPKVDD2	SPKGND2
B2	SPKOUTRP	SPKVDD2	SPKGND2

ABSOLUTE MAXIMUM RATINGS

Absolute Maximum Ratings are stress ratings only. Permanent damage to the device may be caused by continuously operating at or beyond these limits. Device functional operating limits and guaranteed performance specifications are given under Electrical Characteristics at the test conditions specified.



ESD Sensitive Device. This device is manufactured on a CMOS process. It is therefore generically susceptible to damage from excessive static voltages. Proper ESD precautions must be taken during handling and storage of this device.

Wolfson tests its package types according to IPC/JEDEC J-STD-020 for Moisture Sensitivity to determine acceptable storage conditions prior to surface mount assembly. These levels are:

MSL1 = unlimited floor life at <30°C / 85% Relative Humidity. Not normally stored in moisture barrier bag.

MSL2 = out of bag storage for 1 year at <30°C / 60% Relative Humidity. Supplied in moisture barrier bag.

MSL3 = out of bag storage for 168 hours at <30°C / 60% Relative Humidity. Supplied in moisture barrier bag.

The Moisture Sensitivity Level for each package type is specified in Ordering Information.

CONDITION	MIN	MAX
Supply voltages (AVDD1, DBVDD2, DBVDD3)	-0.3V	+4.5V
Supply voltages (AVDD2, DCVDD, DBVDD1)	-0.3V	+2.5V
Supply voltages (CPVDD)	-0.3V	+2.2V
Supply voltages (SPKVDD1, SPKVDD2, LDO1VDD)	-0.3V	+7.0V
Voltage range digital inputs (DBVDD1 domain)	AGND - 0.3V	DBVDD1 + 0.3V
Voltage range digital inputs (DBVDD2 domain)	AGND - 0.3V	DBVDD2 + 0.3V
Voltage range digital inputs (DBVDD3 domain)	AGND - 0.3V	DBVDD3 + 0.3V
Voltage range digital inputs (DMICDATn)	AGND - 0.3V	AVDD1 + 0.3V
Voltage range analogue inputs (AVDD1 domain)	AGND - 0.3V	AVDD1 + 0.3V
Voltage range analogue inputs (MICDET, LINEOUTFB)	AGND - 0.3V	AVDD1 + 0.3V
Voltage range analogue inputs (HPOUT1FB)	AGND - 0.3V	AGND + 0.3V
Ground (DGND, CPGND, SPKGND1, SPKGND2, REFGND, HP2GND)	AGND - 0.3V	AGND + 0.3V
Operating temperature range, T _A	-40°C	+85°C
Junction temperature, T _{JMAX}	-40°C	+150°C
Storage temperature after soldering	-65°C	+150°C

RECOMMENDED OPERATING CONDITIONS

PARAMETER	SYMBOL	MIN	TYP	MAX	UNIT
Digital supply range (Core) See notes 7, 8	DCVDD	1.08	1.2	2.0	V
Digital supply range (I/O)	DBVDD1	1.62	1.8	2.0	V
Digital supply range (I/O)	DBVDD2, DBVDD3	1.62	1.8	3.6	V
Analogue supply 1 range See notes 3, 4, 5, 6	AVDD1	2.4	3.0	3.3	V
Analogue supply 2 range	AVDD2	1.71	1.8	2.0	V
Charge Pump supply range	CPVDD	1.71	1.8	2.0	V
Speaker supply range	SPKVDD1, SPKVDD2	2.7	5.0	5.5	V
LDO1 supply range	LDO1VDD	2.7	5.0	5.5	V
Ground	DGND, AGND, CPGND, SPKGND1, SPKGND2, REFGND, HP2GND		0		V
Power supply rise time See notes 9, 10, 11	All supplies	1			µs
Operating temperature range	T _A	-40		85	°C

Notes:

- Analogue, digital and speaker grounds must always be within 0.3V of AGND.
- There is no power sequencing requirement; the supplies may be enabled in any order.
- AVDD1 must be less than or equal to SPKVDD1 and SPKVDD2.
- An internal LDO (powered by LDO1VDD) can be used to provide the AVDD1 supply.
- When AVDD1 is supplied externally (not from LDO1), the LDO1VDD voltage must be greater than or equal to AVDD1.
- The WM8958 can operate with AVDD1 tied to 0V; power consumption may be reduced, but the analogue audio functions will not be supported.
- An internal LDO (powered by DBVDD1) can be used to provide the DCVDD supply.
- When DCVDD is supplied externally (not from LDO2), the DBVDD1 voltage must be greater than or equal to DCVDD.
- DCVDD and AVDD1 minimum rise times do not apply when these domains are powered using the internal LDOs.
- The specified minimum power supply rise times assume a minimum decoupling capacitance of 100nF per pin. However, Wolfson strongly advises that the recommended decoupling capacitors are present on the PCB and that appropriate layout guidelines are observed (see "Applications Information" section).
- The specified minimum power supply rise times also assume a maximum PCB inductance of 10nH between decoupling capacitor and pin.

THERMAL PERFORMANCE

Thermal analysis should be performed in the intended application to prevent the WM8958 from exceeding maximum junction temperature. Several contributing factors affect thermal performance most notably the physical properties of the mechanical enclosure, location of the device on the PCB in relation to surrounding components and the number of PCB layers. Connecting the GND balls through thermal vias and into a large ground plane will aid heat extraction.

Three main heat transfer paths exist to surrounding air as illustrated below in Figure 1:

- Package top to air (radiation).
- Package bottom to PCB (radiation).
- Package balls to PCB (conduction).

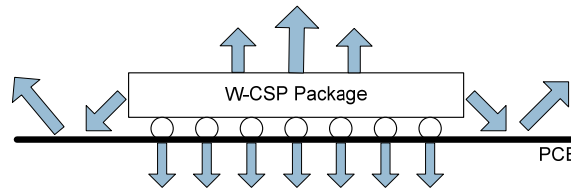

Figure 1 Heat Transfer Paths

The temperature rise T_R is given by $T_R = P_D * \Theta_{JA}$

- P_D is the power dissipated in the device.
- Θ_{JA} is the thermal resistance from the junction of the die to the ambient temperature and is therefore a measure of heat transfer from the die to surrounding air. Θ_{JA} is determined with reference to JEDEC standard JESD51-9.

The junction temperature T_J is given by $T_J = T_A + T_R$, where T_A is the ambient temperature.

PARAMETER	SYMBOL	MIN	TYP	MAX	UNIT
Operating temperature range	T_A	-40		85	°C
Operating junction temperature	T_J	-40		125	°C
Thermal Resistance	Θ_{JA}		48		°C/W

Note:

Junction temperature is a function of ambient temperature and of the device operating conditions. The ambient temperature limits and junction temperature limits must both be observed.

ELECTRICAL CHARACTERISTICS

INPUT SIGNAL LEVEL

Test Conditions

AVDD1 = 3.0V.

With the exception of the condition(s) noted above, the following electrical characteristics are valid across the full range of recommended operating conditions.

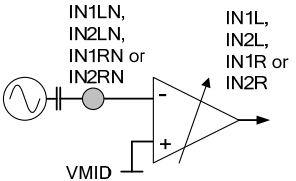
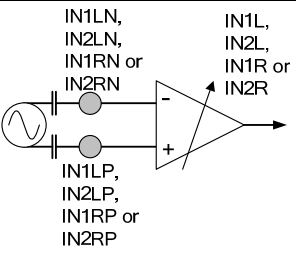
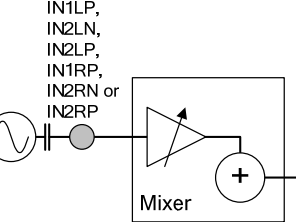
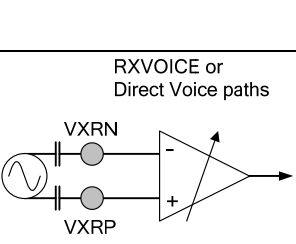
PARAMETER		TEST CONDITIONS		MIN	TYP	MAX	UNIT
A1	Full-Scale PGA Input Signal Level See notes 1, 2, 3 and 4	Single-ended PGA input			1.0 0		Vrms dBV
		Differential PGA input			1.0 0		Vrms dBV
A2	Full-Scale Line Input Signal Level See notes 1, 2, 3 and 4	Single-ended Line input to MIXINL/R, SPKMIXL/R or MIXOUTL/R mixers			1.0 0		Vrms dBV
		Differential mono line input on VRXP/VRXN to RXVOICE or Direct Voice paths to speaker outputs or earpiece output			1.0 0		Vrms dBV

Notes:

1. The full-scale input signal level changes in proportion with AVDD1. It is calculated as AVDD1/3.0.
2. When mixing line inputs, input PGA outputs and DAC outputs the total signal must not exceed 1.0Vrms (0dBV).
3. A 1.0Vrms differential signal equates to 0.5Vrms/-6dBV per input.
4. A sinusoidal input signal is assumed.

INPUT PIN RESISTANCE

Test Conditions

T_A = +25°C.

With the exception of the condition(s) noted above, the following electrical characteristics are valid across the full range of recommended operating conditions.

PARAMETER		TEST CONDITIONS		MIN	TYP	MAX	UNIT
B1	PGA Input Resistance Differential Mode	Gain = -16.5dB (INnx_VOL=00h)			53		kΩ
	See note 5	Gain = 0dB (INnx_VOL=0Bh)			25		kΩ
	See "Applications Information" for details of Input resistance at all PGA Gain settings.	Gain = +30dB (INnx_VOL=1Fh)			1.3		kΩ
B2	PGA Input Resistance Single-Ended Mode	Gain = -16.5dB (INnx_VOL=00h)			58		kΩ
	See note 5	Gain = 0dB (INnx_VOL=0Bh)			36		kΩ
	See "Applications Information" for details of Input resistance at all PGA Gain settings.	Gain = +30dB (INnx_VOL=1Fh)			2.5		kΩ
B3	Line Input Resistance See note 5	IN1LP to MIXINL, or IN1RP to MIXINR Gain = -12dB (IN1xP_MIXINx_VOL=001)			56		kΩ
		IN1LP to MIXINL, or IN1RP to MIXINR Gain = 0dB (IN1xP_MIXINx_VOL=101)			17		kΩ
		IN1LP to MIXINL, or IN1RP to MIXINR Gain = +6dB (IN1xP_MIXINx_VOL=111)			9.8		kΩ
		IN1LP to MIXINL, or IN1RP to MIXINR Gain = +15dB (IN1xP_MIXINx_VOL=111, IN1xP_MIXINx_BOOST=1)			3.7		kΩ
		IN1LP to SPKMIXL, or IN1RP to SPKMIXR (SPKATTN = -12dB)			89		kΩ
		IN1LP to SPKMIXL, or IN1RP to SPKMIXR (SPKATTN = 0dB)			27		kΩ
		IN2LN, IN2RN, IN2LP or IN2RP to MIXOUTL or MIXOUTR Gain = -9dB (*MIXOUTx_VOL=011)			43		kΩ
		IN2LN, IN2RN, IN2LP or IN2RP to MIXOUTL or MIXOUTR Gain = 0dB (*MIXOUTx_VOL=000)			18		kΩ

Test ConditionsT_A = +25°C.

With the exception of the condition(s) noted above, the following electrical characteristics are valid across the full range of recommended operating conditions.

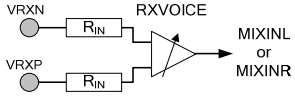
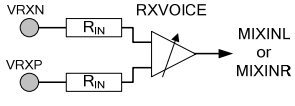
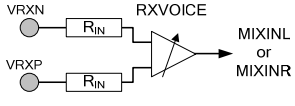
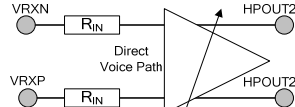
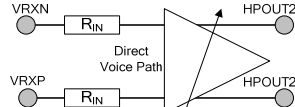
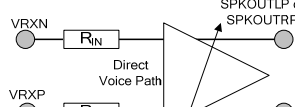
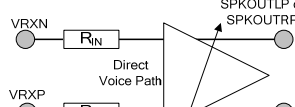
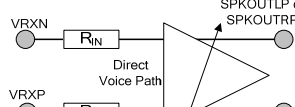
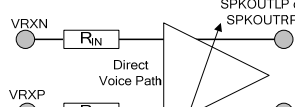
PARAMETER	TEST CONDITIONS	MIN	TYP	MAX	UNIT
	RXVOICE to MIXINL or MIXINR Gain = -12dB (IN2LRP_MIXINx_VOL=001) 		48		kΩ
	RXVOICE to MIXINL or MIXINR Gain = 0dB (IN2LRP_MIXINx_VOL=101) 		12		kΩ
	RXVOICE to MIXINL or MIXINR Gain = +6dB (IN2LRP_MIXINx_VOL=111) 		6.0		kΩ
	Direct Voice to Earpiece Gain = -6dB (HPOUT2_VOL=1) 		20		kΩ
	Direct Voice to Earpiece Gain = 0dB (HPOUT2_VOL=0) 		10		kΩ
	Direct Voice to Speaker Gain = 0dB (SPKOUTx_BOOST=000) 		170		kΩ
	Direct Voice to Speaker Gain = +6dB (SPKOUTx_BOOST=100) 		85		kΩ
	Direct Voice to Speaker Gain = +9dB (SPKOUTx_BOOST=110) 		60		kΩ
	Direct Voice to Speaker Gain = +12dB (SPKOUTx_BOOST=111) 		43		kΩ

Note 5: Input resistance will be seen in parallel with the resistance of other enabled input paths from the same pins

PROGRAMMABLE GAINS

Test Conditions

The following electrical characteristics are valid across the full range of recommended operating conditions.

PARAMETER		TEST CONDITIONS	MIN	TYP	MAX	UNIT
Input PGAs (IN1L, IN2L, IN1R and IN2R)						
C1	Minimum Programmable Gain	Guaranteed monotonic		-16.5		dB
C2	Maximum Programmable Gain			+30		dB
C3	Programmable Gain Step Size			1.5		dB
Input Mixers (MIXINL and MIXINR)						
C6	Minimum Programmable Gain	Input PGA signal paths		0		dB
C7	Maximum Programmable Gain			+30		dB
C8	Programmable Gain Step Size			30		dB
C9	Minimum Programmable Gain	Direct IN1xP input signal paths (Note the available gain settings are -12, -9, -6, -3, 0, +3, +6, +15dB)		-12		dB
C10	Maximum Programmable Gain			+15		dB
C11	Programmable Gain Step Size			3		dB
	Minimum Programmable Gain	MIXOUTx Record signal paths		-12		dB
	Maximum Programmable Gain			+6		dB
	Programmable Gain Step Size			3		dB
C12	Minimum Programmable Gain	RXVOICE (VRXP-VRXN) signal paths		-12		dB
C13	Maximum Programmable Gain			+6		dB
C14	Programmable Gain Step Size			3		dB
Output Mixers (MIXOUTL and MIXOUTR)						
C17	Minimum Programmable Gain			-9		dB
C18	Maximum Programmable Gain			0		dB
C19	Programmable Gain Step Size			3		dB
Speaker Mixers (SPKMIXL and SPKMIXR)						
C21	Minimum Programmable Gain			-15		dB
C22	Maximum Programmable Gain			0		dB
C23	Programmable Gain Step Size			3		dB
Output PGAs (HPOUT1LVOL, HPOUT1RVOL, MIXOUTLVOL, MIXOUTRVOL, SPKLVOL and SPKRVOL)						
C25	Minimum Programmable Gain	Guaranteed monotonic		-57		dB
C26	Maximum Programmable Gain			+6		dB
C27	Programmable Gain Step Size			1		dB
Line Output Drivers (LINEOUT1NMIX, LINEOUT1PMIX, LINEOUT2NMIX and LINEOUT2PMIX)						
C29	Minimum Programmable Gain			-6		dB
C30	Maximum Programmable Gain			0		dB
C31	Programmable Gain Step Size			6		dB
Earpiece Driver (HPOUT2MIX)						
C33	Minimum Programmable Gain			-6		dB
C34	Maximum Programmable Gain			0		dB
C35	Programmable Gain Step Size			6		dB
Speaker Output Drivers (SPKOUTLBOOST and SPKOUTRBOOST)						
C38	Minimum Programmable Gain	(Note the available gain settings are 0, +1.5, +3, +4.5, +6, +7.5, +9, +12dB)		0		dB
C39	Maximum Programmable Gain			+12		dB
C40	Programmable Gain Step Size			1.5		dB

OUTPUT DRIVER CHARACTERISTICS

Test Conditions

The following electrical characteristics are valid across the full range of recommended operating conditions.

PARAMETER		TEST CONDITIONS	MIN	TYP	MAX	UNIT
Line Output Driver (LINEOUT1P, LINEOUT1N, LINEOUT2P, LINEOUT2N)						
	Load resistance		2			k Ω
	Load capacitance	Direct connection			100	pF
		Connection via 1k Ω series resistor			2000	
	Output discharge resistance	LINEOUTn_DISCH=1, VROI=0		8		k Ω
		LINEOUTn_DISCH=1, VROI=1, LINEOUTn_ENA=0		500		Ω
Headphone Output Driver (HPOUT1L, HPOUT1R)						
	Load resistance	Normal operation	15			Ω
		Device survival with load applied indefinitely (see note 6)	100			m Ω
	Load capacitance				2	nF
	DC offset across load	DC Servo complete		TBD		mV
Earpiece Output Driver (HPOUT2L, HPOUT2R)						
	Load resistance		15			Ω
	Load capacitance	Direct connection			200	pF
	DC offset across load			± 5		mV
Speaker Output Driver (SPKOUTLP, SPKOUTLN, SPKOUTRP, SPKOUTRN)						
	Load resistance	Stereo Mode (SPKMODE=0), Class AB	8			Ω
		Stereo Mode (SPKMODE=0), Class D	4			
		Mono Mode (SPKMODE=1)	4			
	Load capacitance				TBD	pF
	DC offset across load			± 5		mV
	SPKVDD leakage current	Sum of I _{SPKVDD1} + I _{SPKVDD2}		1		μ A

Note 6: In typical applications, the PCB trace resistance, jack contact resistance and ESR of any series passive components (eg. inductor or ferrite bead) are sufficient to provide this minimum resistance; additional series components are not required.

ADC INPUT PATH PERFORMANCE

Test Conditions

AVDD1=3.0V (powered from LDO1), DCVDD=1.2V (powered from LDO2), AVDD2=DBVDD1=DBVDD2=DBVDD3=CPVDD=1.8V, LDO1VDD=SPKVDD1=SPKVDD2=5V, DGND=AGND=CPGND=SPKGND1=SPKGND2=HP2GND=0V, T_A = +25°C, 1kHz sinusoidal signal, f_s = 48kHz, PGA gain = 0dB, 24-bit audio data unless otherwise stated.

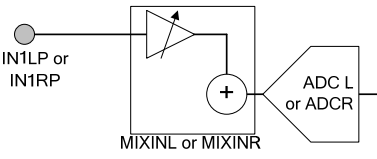
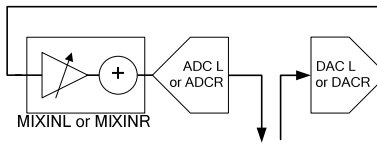
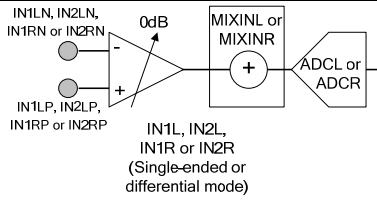
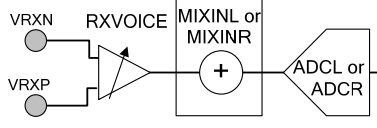
PARAMETER	TEST CONDITIONS	MIN	TYP	MAX	UNIT	
D1	Line Inputs to ADC via MIXINL and MIXINR					
	SNR	A-weighted		94		dB
	THD	-1dBV input		-83		dB
	THD+N	-1dBV input		-81		dB
	Channel Separation (L/R)			100		dB
PSRR (all supplies)	100mV (pk-pk) 217Hz	73			dB	
D2	Record Path (DACs to ADCs via MIXINL and MIXINR)					
	SNR	A-weighted		92		dB
	THD	-1dBFS input		-74		dB
	THD+N	-1dBFS input		-72		dB
Channel Separation (L/R)		95			dB	
D3	Input PGAs to ADC via MIXINL or MIXINR					
	SNR	A-weighted		84	95	dB
	THD	-1dBV input		-82	-72	dB
	THD+N	-1dBV input		-80	-70	dB
	Channel Separation (L/R)			100		dB
PSRR (AVDD1)	100mV (pk-pk) 217Hz	97			dB	
D4	RXVOICE to ADCL or ADCR					
	SNR	A-weighted		94		dB
	THD	-1dBV input		-84		dB
THD+N	-1dBV input	-82			dB	

DAC OUTPUT PATH PERFORMANCE

Test Conditions

AVDD1=3.0V (powered from LDO1), DCVDD=1.2V (powered from LDO2), AVDD2=DBVDD1=DBVDD2=DBVDD3=CPVDD=1.8V, LDO1VDD=SPKVDD1=SPKVDD2=5V, DGND=AGND=CPGND=SPKGND1=SPKGND2=HP2GND=0V, $T_A = +25^\circ\text{C}$, 1kHz sinusoidal signal, $f_s = 48\text{kHz}$, PGA gain = 0dB, 24-bit audio data unless otherwise stated.

PARAMETER	TEST CONDITIONS		MIN	TYP	MAX	UNIT	
E1	DAC to Single-Ended Line Output (Load = 10kΩ // 50pF)						
	SNR	A-weighted		93		dB	
	THD	0dBFS input		-75		dB	
	THD+N	0dBFS input		-73		dB	
	Channel Separation (L/R)			70		dB	
	PSRR (all supplies)	100mV (pk-pk) 217Hz		36		dB	
	LINEOUTFB rejection	LINEOUTn_FB=1, 100mV (pk-pk) 217Hz		38		dB	
E2	DAC to Differential Line Output (Load = 10kΩ // 50pF)						
	SNR	A-weighted		97		dB	
	THD	0dBFS input		-76		dB	
	THD+N	0dBFS input		-75		dB	
	Channel Separation (L/R)			90		dB	
	PSRR (all supplies)	100mV (pk-pk) 217Hz		51		dB	
E5	DAC to Headphone on HPOUT1L or HPOUT1R (Load = 32Ω)						
	SNR (A-weighted)	DAC_OS128=1		100		dB	
		DAC_OS128=0		97		dB	
	THD	$P_o=20\text{mW}$		-74		dB	
	THD+N	$P_o=20\text{mW}$		-72		dB	
	THD	$P_o=5\text{mW}$		-76		dB	
	THD+N	$P_o=5\text{mW}$		-74		dB	
	Channel Separation (L/R)			95		dB	
	PSRR (all supplies)	100mV (pk-pk) 217Hz		51		dB	
	HPOUT1FB rejection	100mV (pk-pk) 217Hz		29		dB	
E6	DAC to Headphone on HPOUT1L or HPOUT1R (Load = 16Ω)						
	SNR (A-weighted)	DAC_OS128=1		90	100		dB
		DAC_OS128=0		97		dB	
	THD	$P_o=20\text{mW}$		-82		dB	
	THD+N	$P_o=20\text{mW}$		-80		dB	
	THD	$P_o=5\text{mW}$		-83	-73	dB	
	THD+N	$P_o=5\text{mW}$		-81	-71	dB	
	Channel Separation (L/R)			95		dB	
	PSRR (all supplies)	100mV (pk-pk) 217Hz		51		dB	
	HPOUT1FB rejection	100mV (pk-pk) 217Hz		29		dB	

Test Conditions

AVDD1=3.0V (powered from LDO1), DCVDD=1.2V (powered from LDO2), AVDD2=DBVDD1=DBVDD2=DBVDD3=CPVDD=1.8V, LDO1VDD=SPKVDD1=SPKVDD2=5V, DGND=AGND=CPGND=SPKGND1=SPKGND2=HP2GND=0V, T_A = +25°C, 1kHz sinusoidal signal, f_s = 48kHz, PGA gain = 0dB, 24-bit audio data unless otherwise stated.

PARAMETER	TEST CONDITIONS		MIN	TYP	MAX	UNIT	
E9	DAC to Earpiece Driver (Load = 16Ω BTL)						
	SNR	A-weighted			97		dB
	THD	P _O =50mW			-71		dB
	THD+N	P _O =50mW			-69		dB
	PSRR (all supplies)	100mV (pk-pk) 217Hz			51		dB
E12 DAC to Speaker Outputs (Load = 8Ω + 22μH BTL, Stereo Mode) Class D Mode, +12dB boost (SPKOUTx_BOOST = 111)							
SNR	A-weighted			85	94	dB	
	THD			P _O =0.5W	-65		dB
	THD+N			P _O =0.5W	-63	-53	dB
	THD			P _O =1.0W	-70		dB
	THD+N			P _O =1.0W	-68		dB
	PSRR (all supplies)			100mV (pk-pk) 217Hz	43		dB
	Channel Separation (L/R)				80		dB
DAC to Speaker Outputs (Load = 8Ω + 22μH BTL, Stereo Mode) Class AB Mode, +12dB boost (SPKOUTx_BOOST = 111)							
SNR	A-weighted			96		dB	
	THD			P _O =0.5W	-67		dB
	THD+N			P _O =0.5W	-65		dB
	THD			P _O =1.0W	-64		dB
	THD+N			P _O =1.0W	-62		dB
	PSRR (all supplies)			100mV (pk-pk) 217Hz	43		dB
	Channel Separation (L/R)				80		dB
DAC to Speaker Outputs (Load = 4Ω + 22μH BTL, Stereo Mode) Class D Mode, +12dB boost (SPKOUTx_BOOST = 111)							
SNR	A-weighted			93		dB	
	THD			P _O =0.5W			dB
	THD+N			P _O =0.5W	-63		dB
	THD			P _O =1.0W			dB
	THD+N			P _O =1.0W	-63		dB
	THD			P _O =2.0W			dB
	THD+N			P _O =2.0W	-66		dB
	PSRR (all supplies)			100mV (pk-pk) 217Hz			dB
	Channel Separation (L/R)						dB

Test Conditions

AVDD1=3.0V (powered from LDO1), DCVDD=1.2V (powered from LDO2), AVDD2=DBVDD1=DBVDD2=DBVDD3=CPVDD=1.8V, LDO1VDD=SPKVDD1=SPKVDD2=5V, DGND=AGND=CPGND=SPKGND1=SPKGND2=HP2GND=0V, $T_A = +25^\circ\text{C}$, 1kHz sinusoidal signal, $f_s = 48\text{kHz}$, PGA gain = 0dB, 24-bit audio data unless otherwise stated.

PARAMETER	TEST CONDITIONS		MIN	TYP	MAX	UNIT	
E13	Speaker Output Power (Load = 8Ω + 22μH BTL, Stereo Mode)						
	Output Power	SPKVDD1= SPKVDD2=5.0V THD+N ≤ 1%	Class AB		1		W
			Class D		1		
		SPKVDD1= SPKVDD2=4.2V THD+N ≤ 1%	Class AB		0.95		W
			Class D		0.95		
		SPKVDD1= SPKVDD2=3.7V THD+N ≤ 1%	Class AB		0.75		W
			Class D		0.75		
	Note that the maximum recommended speaker output power is 1W per channel into 8Ω. Output levels that exceed this limit are not guaranteed and may cause damage to the WM8958.						
	Speaker Output Power (Load = 4Ω + 22μH BTL, Stereo Mode)						
	Output Power	SPKVDD1= SPKVDD2=5.0V THD+N ≤ 1%	Class D (see note below)		2.3		W
			Class D		1.6		
			Class D		1.2		
Speaker Output Power (Load = 4Ω + 22μH BTL, Mono Mode)							
Output Power	SPKVDD1= SPKVDD2=5.0V THD+N ≤ 1%	Class AB (see note below)		2.7		W	
		Class D (see note below)		2.7			
Note that the maximum recommended speaker output power is 2W per channel into 4Ω. Output levels that exceed this limit are not guaranteed and may cause damage to the WM8958.							

BYPASS PATH PERFORMANCE

Test Conditions

AVDD1=3.0V (powered from LDO1), DCVDD=1.2V (powered from LDO2), AVDD2=DBVDD1=DBVDD2=DBVDD3=CPVDD=1.8V, LDO1VDD=SPKVDD1=SPKVDD2=5V, DGND=AGND=CPGND=SPKGND1=SPKGND2=HP2GND=0V, T_A = +25°C, 1kHz sinusoidal signal, f_s = 48kHz, PGA gain = 0dB, 24-bit audio data unless otherwise stated.

PARAMETER	TEST CONDITIONS	MIN	TYP	MAX	UNIT	
F1	Input PGA to Differential Line Output (Load = 10kΩ // 50pF)					
	SNR	A-weighted		100		dB
	THD	0dBV output		-90		dB
	THD+N	0dBV output		-87		dB
F3	Input PGA to Headphone via MIXOUTL or MIXOUTR (Load = 16Ω)					
	SNR	A-weighted		98		dB
	THD	P _O =20mW		-89		dB
	THD+N	P _O =20mW		-87		dB
	THD	P _O =5mW		-86		dB
	THD+N	P _O =5mW		-84		dB
	PSRR (all supplies)	100mV (pk-pk) 217Hz		49		dB
	Channel Separation (L/R)			95		dB
F2	Line Input (IN2LP or IN2RP) to Headphone via MIXOUTL or MIXOUTR (Load = 16Ω)					
	SNR	A-weighted		100		dB
	THD	P _O =20mW		-86		dB
	THD+N	P _O =20mW		-84		dB
	THD	P _O =5mW		-84		dB
	THD+N	P _O =5mW		-82		dB
	PSRR (all supplies)	100mV (pk-pk) 217Hz		49		dB
F4	Line Input (IN2LN or IN2RN) to Headphone via MIXOUTL or MIXOUTR (Load = 16Ω)					
	SNR	A-weighted		100		dB
	THD	P _O =20mW		-84		dB
	THD+N	P _O =20mW		-82		dB
	THD	P _O =5mW		-82		dB
	THD+N	P _O =5mW		-80		dB
	PSRR (all supplies)	100mV (pk-pk) 217Hz		49		dB
	Channel Separation (L/R)			95		dB

Test Conditions

AVDD1=3.0V (powered from LDO1), DCVDD=1.2V (powered from LDO2), AVDD2=DBVDD1=DBVDD2=DBVDD3=CPVDD=1.8V, LDO1VDD=SPKVDD1=SPKVDD2=5V, DGND=AGND=CPGND=SPKGND1=SPKGND2=HP2GND=0V, $T_A = +25^\circ\text{C}$, 1kHz sinusoidal signal, $f_s = 48\text{kHz}$, PGA gain = 0dB, 24-bit audio data unless otherwise stated.

PARAMETER	TEST CONDITIONS		MIN	TYP	MAX	UNIT
F5	Direct Voice Path to Earpiece Driver (Load = 16Ω BTL)					
	SNR	A-weighted		90	104	dB
	THD	$P_O=50\text{mW}$		-70		dB
	THD+N	$P_O=50\text{mW}$		-68	-60	dB
	PSRR (all supplies)	100mV (pk-pk) 217Hz		91		dB
F6	Direct Voice Path to Speaker Outputs (Load = 8Ω + 22μH BTL, Stereo Mode) Class D Mode, +12dB boost (SPKOUTx_BOOST = 111)					
	SNR	A-weighted			97	dB
	THD	$P_O=0.5\text{W}$		-62		dB
	THD+N	$P_O=0.5\text{W}$		-60		dB
	THD	$P_O=1.0\text{W}$		-67		dB
	THD+N	$P_O=1.0\text{W}$		-65		dB
	PSRR (all supplies)	100mV (pk-pk) 217Hz		63		dB
	Direct Voice Path to Speaker Outputs (Load = 8Ω + 22μH BTL, Stereo Mode) Class AB Mode, +12dB boost (SPKOUTx_BOOST = 111)					
	SNR	A-weighted			103	dB
	THD	$P_O=0.5\text{W}$		-62		dB
	THD+N	$P_O=0.5\text{W}$		-60		dB
	THD	$P_O=1.0\text{W}$		-64		dB
	THD+N	$P_O=1.0\text{W}$		-62		dB
PSRR (all supplies)	100mV (pk-pk) 217Hz	67			dB	
F7	Line Input to Speaker Outputs via SPKMIXL or SPKMIXR (Load = 8Ω + 22μH BTL, Stereo Mode) Class D Mode, +12dB boost (SPKOUTx_BOOST = 111)					
	SNR	A-weighted			93	dB
	THD	$P_O=0.5\text{W}$		-62		dB
	THD+N	$P_O=0.5\text{W}$		-60		dB
	THD	$P_O=1.0\text{W}$		-67		dB
	THD+N	$P_O=1.0\text{W}$		-65		dB
	PSRR (all supplies)	100mV (pk-pk) 217Hz		47		dB
	Line Input to Speaker Outputs via SPKMIXL or SPKMIXR (Load = 8Ω + 22μH BTL, Stereo Mode) Class AB Mode, +12dB boost (SPKOUTx_BOOST = 111)					
	SNR	A-weighted			96	dB
	THD	$P_O=0.5\text{W}$		-72		dB
	THD+N	$P_O=0.5\text{W}$		-68		dB
	THD	$P_O=1.0\text{W}$		-64		dB
	THD+N	$P_O=1.0\text{W}$		-62		dB
PSRR (all supplies)	100mV (pk-pk) 217Hz	47			dB	

MULTI-PATH CROSSTALK

Test Conditions

AVDD1=3.0V (powered from LDO1), DCVDD=1.2V (powered from LDO2), AVDD2=DBVDD1=DBVDD2=DBVDD3=CPVDD=1.8V, LDO1VDD=SPKVDD1=SPKVDD2=5V, DGND=AGND=CPGND=SPKGND1=SPKGND2=HP2GND=0V, T_A = +25°C, 1kHz sinusoidal signal, fs = 48kHz, PGA gain = 0dB, 24-bit audio data unless otherwise stated.

PARAMETER	TEST CONDITIONS	MIN	TYP	MAX	UNIT
G1 Headset Voice Call: DAC/Headset to Tx Voice Separation 1kHz 0dBFS DAC playback direct to HPOUT1L and HPOUT1R; Quiescent input on IN1LN/P or IN1RN/P (Gain=+12dB), differential line output; Measure crosstalk at differential line output			85		dB
G2 Speakerphone Voice Call: DAC/Speaker to Tx Voice Separation 1kHz 0dBFS DAC playback to speakers, 1W/ch output; Quiescent input on IN1LN/P or IN1RN/P (Gain=+12dB), differential line output; Measure crosstalk at differential line output			100		dB
G3 Earpiece PCM Voice Call: RXVOICE to Tx Voice Separation fs=8kHz for ADC and DAC, DAC_SB_FILT=1; -5dBFS, DAC output to HPOUT2P-HPOUT2N; Quiescent input on input PGA (Gain=+12dB) to ADC via MIXINL or MIXINR; Measure crosstalk at ADC output			110		dB
G4 Speakerphone PCM Voice Call: DAC/Speaker to ADC Separation fs=8kHz for ADC and DAC, DAC_SB_FILT=1; 0dBFS DAC output to speaker (1W output); ADC record from input PGA (Gain=+30dB); Measure crosstalk on ADC output			90		dB
G5 Speakerphone PCM Voice Call: ADC to DAC/Speaker Separation fs=8kHz for ADC and DAC, DAC_SB_FILT=1; Quiescent DAC output to speaker; ADC record from input PGA (Gain=+30dB + 30dB boost); Measure crosstalk on speaker output			95		dB

Test Conditions

AVDD1=3.0V (powered from LDO1), DCVDD=1.2V (powered from LDO2), AVDD2=DBVDD1=DBVDD2=DBVDD3=CPVDD=1.8V, LDO1VDD=SPKVDD1=SPKVDD2=5V, DGND=AGND=CPGND=SPKGND1=SPKGND2=HP2GND=0V, T_A = +25°C, 1kHz sinusoidal signal, fs = 48kHz, PGA gain = 0dB, 24-bit audio data unless otherwise stated.

PARAMETER	TEST CONDITIONS	MIN	TYP	MAX	UNIT
<p>G6 Earpiece Speaker Voice Call: Tx Voice and RXVOICE Separation</p> <p>1kHz Full scale differential input on VRXP-VRXN, output to HPOUT2P-HPOUT2N; Quiescent input on IN1LN/P or IN1RN/P (Gain=+12dB), differential line output; Measure crosstalk at differential line output</p>			100		dB
<p>G7 Headset Voice Call: Tx Voice and RXVOICE Separation</p> <p>1kHz full scale differential input on VRXP-VRXN via RXVOICE to MIXOUTL and MIXOUTR, output to HPOUT1L and HPOUT1R; Quiescent input on IN1LN/P or IN1RN/P (Gain=+12dB), differential line output; Measure crosstalk at differential line output</p>			90		dB
<p>G8 Stereo Line Record and Playback: DAC/Headset to ADC Separation</p> <p>-5dBFS input to DACs, playback to HPOUT1L and HPOUT1R; ADC record from line input; Measure crosstalk on ADC output</p>			95		dB

DIGITAL INPUT / OUTPUT**Test Conditions**

The following electrical characteristics are valid across the full range of recommended operating conditions.

PARAMETER	TEST CONDITIONS	MIN	TYP	MAX	UNIT
Digital Input / Output (except DMICDATn and DMICCLK)					
Digital I/O is referenced to DBVDD1, DBVDD2 or DBVDD3. See "Pin Description" for the domain applicable to each pin.					
H16	Input HIGH Level, V_{IH}		$0.8 \times$ DBVDDn		V
H17	Input LOW Level, V_{IL}			$0.2 \times$ DBVDDn	V
Note that digital input pins should not be left unconnected / floating.					
H18	Output HIGH Level, V_{OH}	$I_{OH}=1\text{mA}$	$0.8 \times$ DBVDDn		V
H19	Output LOW Level, V_{OL}	$I_{OL}=-1\text{mA}$		$0.2 \times$ DBVDDn	V
H20	Input capacitance		10		pF
H21	Input leakage		-0.9	0.9	μA
Digital Microphone Input / Output (DMICDATn and DMICCLK)					
H22	DMICDATn input HIGH Level, V_{IH}		$0.65 \times$ MICBIAS1		V
H23	DMICDATn input LOW Level, V_{IL}			$0.35 \times$ MICBIAS1	V
H24	DMICCLK output HIGH Level, V_{OH}	$I_{OH}=1\text{mA}$	$0.8 \times$ MICBIAS1		V
H25	DMICCLK output LOW Level, V_{OL}	$I_{OL}=-1\text{mA}$		$0.2 \times$ MICBIAS1	V
H26	Input capacitance		10		pF
H27	Input leakage		-0.9	0.9	μA

DIGITAL FILTER CHARACTERISTICS**Test Conditions**

The following electrical characteristics are valid across the full range of recommended operating conditions.

PARAMETER	TEST CONDITIONS	MIN	TYP	MAX	UNIT
ADC Decimation Filter					
Passband	+/- 0.05dB	0		0.454 fs	
	-6dB		0.5 fs		
Passband Ripple				+/- 0.05	dB
Stopband		0.546 fs			
Stopband Attenuation	$f > 0.546 \text{ fs}$	85			dB
Group Delay				2	ms
DAC Interpolation Filter					
Passband	+/- 0.05dB	0		0.454 fs	
	-6dB		0.5 fs		
Passband Ripple	0.454 fs			+/- 0.05	dB
Stopband		0.546 fs			
Stopband Attenuation	$f > 0.546 \text{ fs}$	85			dB
Group Delay				2	ms

MICROPHONE BIAS CHARACTERISTICS

Test Conditions

AVDD1=3.0V (powered from LDO1), DCVDD=1.2V (powered from LDO2), AVDD2=DBVDD1=DBVDD2=DBVDD3=CPVDD=1.8V, LDO1VDD=SPKVDD1=SPKVDD2=5V, DGND=AGND=CPGND=SPKGND1=SPKGND2=HP2GND=0V, $T_A = +25^\circ\text{C}$, unless otherwise stated.

PARAMETER	TEST CONDITIONS	MIN	TYP	MAX	UNIT	
Microphone Bias (MICBIAS1 and MICBIAS2)						
Note - No capacitor on MICBIASn						
Note - In regulator mode, it is required that $AVDD1 - V_{MICBIASn} > 200\text{mV}$						
H2	Bias Voltage Regulator mode (MICBn_MODE=0) Load current $\leq 1.0\text{mA}$	MICBn_LVL = 000	-5%	1.5	+5%	V
		MICBn_LVL = 001	-5%	1.8	+5%	
		MICBn_LVL = 010	-5%	1.9	+5%	
		MICBn_LVL = 011	-5%	2.0	+5%	
		MICBn_LVL = 100	-5%	2.2	+5%	
		MICBn_LVL = 101	-5%	2.4	+5%	
		MICBn_LVL = 110	-5%	2.5	+5%	
	MICBn_LVL = 111	-5%	2.6	+5%		
Bias Voltage Bypass mode (MICBn_MODE=1) Load current $\leq 3.6\text{mA}$		AVDD1 - 80mV		AVDD1	V	
H3	Bias Current	Regulator mode (MICBn_MODE=0)			2.4	mA
		Bypass mode (MICBn_MODE=1)			3.6	
H4	Output Noise Density	Regulator mode (MICBn_MODE=0), MICBn_LVL = 100, Load current = 1mA, Measured at 1kHz		60		nV/ $\sqrt{\text{Hz}}$
H5	Integrated Noise Voltage	Regulator mode (MICBn_MODE=0), MICBn_LVL = 100, Load current = 1mA, 100Hz to 7kHz, A-weighted		4.5		μV_{RMS}
H6	PSRR (AVDD1)	100mV (pk-pk) 217Hz		100		dB
		100mV (pk-pk) 10kHz		80		
	Load capacitance	Regulator mode (MICBn_MODE=0)			50	pF
	Output discharge resistance	MICBn_ENA=0, MICBn_DISCH=1		20		k Ω

MISCELLANEOUS CHARACTERISTICS

Test Conditions

AVDD1=3.0V (powered from LDO1), DCVDD=1.2V (powered from LDO2), AVDD2=DBVDD1=DBVDD2=DBVDD3=CPVDD=1.8V, LDO1VDD=SPKVDD1=SPKVDD2=5V, DGND=AGND=CPGND=SPKGND1=SPKGND2=HP2GND=0V, T_A = +25°C, 1kHz sinusoidal signal, fs = 48kHz, PGA gain = 0dB, 24-bit audio data unless otherwise stated.

PARAMETER	TEST CONDITIONS	MIN	TYP	MAX	UNIT	
Analogue Reference Levels						
H1	VMID Midrail Reference Voltage	VMID_SEL = 01, 4.7μF capacitor on VMIDC	-3%	AVDD1/2	+3%	V
	VMID Start-Up time	VMID_SEL = 01, VMID_RAMP = 11, 4.7μF capacitor on VMIDC			50	ms
External Accessory Detection						
	Load impedance detection range (MICDET) 2.2kΩ (2%) MICBIAS2 resistor. Note these characteristics assume no other component is connected to MICDET. See "Applications Information" for recommended external components when a typical microphone is present.	for MICD_LVL[0] = 1	0		3	Ω
		for MICD_LVL[1] = 1	13.33		15.27	
		for MICD_LVL[2] = 1	27.16		30.96	
		for MICD_LVL[3] = 1	42.48		49.47	
		for MICD_LVL[4] = 1	65		85	
		for MICD_LVL[5] = 1	114		155.24	
		for MICD_LVL[6] = 1	191		329.87	
	for MICD_LVL[7] = 1	475		30000		
Frequency Locked Loops (FLLs)						
H29	Lock time	F _{REF} =32kHz, F _{OUT} =12.288MHz		2.5		ms
		F _{REF} =12MHz, F _{OUT} =12.288MHz		300		μs
H30	Free-running mode start-up time			100		μs
H31	Free-running mode frequency accuracy	Reference supplied initially		+/-10		%
		No reference provided		+/-30		%
LDO Regulators						
H38	LDO1 Start-Up Time	4.7μF capacitor on AVDD1 1μF capacitor on VREFC			1.5	ms
	LDO1 Drop-Out voltage (LDO1VDD - AVDD1)				300	mV
	LDO1 PSRR (LDO1VDD)	100mV (pk-pk) 217Hz		TBD		dB
H42	LDO2 Start-Up Time	2.2μF capacitor on DCVDD 1μF capacitor on VREFC			1.5	ms
	LDO2 PSRR (DBVDD1)	100mV (pk-pk) 217Hz		TBD		dB

TERMINOLOGY

1. Signal-to-Noise Ratio (dB) – SNR is a measure of the difference in level between the maximum full scale output signal and the output with no input signal applied.
2. Total Harmonic Distortion (dB) – THD is the level of the rms value of the sum of harmonic distortion products relative to the amplitude of the measured output signal.
3. Total Harmonic Distortion plus Noise (dB) – THD+N is the level of the rms value of the sum of harmonic distortion products plus noise in the specified bandwidth relative to the amplitude of the measured output signal.
4. Power Supply Rejection Ratio (dB) - PSRR is the ratio of a specified power supply variation relative to the output signal that results from it. PSRR is measured under quiescent signal path conditions.
5. Common Mode Rejection Ratio (dB) – CMRR is the ratio of a specified input signal (applied to both sides of a differential input), relative to the output signal that results from it.
6. Channel Separation (L/R) (dB) – left-to-right and right-to-left channel separation is the difference in level between the active channel (driven to maximum full scale output) and the measured signal level in the idle channel at the test signal frequency. The active channel is configured and supplied with an appropriate input signal to drive a full scale output, with signal measured at the output of the associated idle channel.
7. Multi-Path Crosstalk (dB) – is the difference in level between the output of the active path and the measured signal level in the idle path at the test signal frequency. The active path is configured and supplied with an appropriate input signal to drive a full scale output, with signal measured at the output of the specified idle path.
8. Mute Attenuation – This is a measure of the difference in level between the full scale output signal and the output with mute applied.
9. All performance measurements carried out with 20kHz low pass filter, and where noted an A-weighted filter. Failure to use such a filter will result in higher THD and lower SNR readings than are found in the Electrical Characteristics. The low pass filter removes out of band noise; although it is not audible it may affect dynamic specification values.

TYPICAL PERFORMANCE

TYPICAL POWER CONSUMPTION

OPERATING MODE	TEST CONDITIONS	SPKVDD (Note 3)	LDO1VDD	AVDD2	CPVDD	DBVDD (Note 4)	TOTAL
Off (Battery Leakage only)							
LDO1 disabled, LDO2 disabled		4.2V 1.1µA	4.2V 0.4µA	0.0V 5.5µA	0.0V 5µA	0.0V 9.5µA	0.01mW
Standby							
LDO1 disabled, LDO2 enabled	All supplies present, No clocks, Default register settings	4.2V 1.8µA	4.2V 1µA	1.8V 60µA	1.8V 5µA	1.8V 62µA	0.2mW
Standby							
LDO1 enabled, LDO2 enabled	All supplies present, No clocks, Default register settings	4.2V 1.8µA	4.2V 89µA	1.8V 65µA	1.8V 5µA	1.8V 72µA	0.6mW
Music playback to Headphone (32ohm load)							
AIF1 to DAC to HPOUT1 (stereo)	fs=44.1kHz, Clocking rate=256fs, 24-bit I2S, Slave mode	4.2V 0.0mA	4.2V 2.05mA	1.8V 0.32mA	1.8V 0.48mA	1.8V 1.13mA	12.1mW
AIF1 to DAC to HPOUT1 (stereo) LDOs disabled, See Note 7	fs=44.1kHz, Clocking rate=128fs, 24-bit I2S, Slave mode, Class W	3.6V 0.0mA	AVDD1= 2.4V 1.43mA	1.8V 0.21mA	1.8V 0.21mA	DBVDD= 1.8V 0.01mA DCVDD= 1.2V 0.94mA	5.34mW
Music playback to Class D speaker output (8ohm, 22µH load)							
AIF1 to DAC to SPKOUT (stereo)	fs=44.1kHz, Clocking rate=256fs, 24-bit I2S, Slave mode, +7.5dB Class D boost	4.2V 1.65mA	4.2V 2.36mA	1.8V 1.24mA	1.8V 0.01mA	1.8V 1.13mA	21.1mW
AIF1 to DAC to SPKOUT (Left)	fs=44.1kHz, Clocking rate=256fs, 24-bit I2S, Slave mode, +0.0dB Class D boost	4.2V 0.74mA	4.2V 2.34mA	1.8V 0.79mA	1.8V 0.01mA	1.8V 1.13mA	16.4mW
AIF1 to AIF3 Mono Digital Bypass (eg. Bluetooth video call)							
AIF1(L) to AIF3(L), AIF3(L) to AIF1(L)	fs=8kHz, Clocking rate=256fs, 24-bit I2S, Slave mode	4.2V 0.0mA	4.2V 0.09mA	1.8V 0.07mA	1.8V 0.01mA	1.8V 0.41mA	1.2mW
AIF2 to AIF3 Mono Digital Bypass (eg. Bluetooth voice call)							
AIF2(L) to AIF3(L), AIF3(L) to AIF2(L)	fs=8kHz, Clocking rate=256fs, 24-bit I2S, Slave mode	4.2V 0.002mA	4.2V 0.089mA	1.8V 0.065mA	1.8V 0.003mA	1.8V 0.311mA	1.1mW

Notes:

- AVDD1 = 3.0V, generated by LDO1.
- DCVDD = 1.2V, generated by LDO2.
- SPKVDD = SPKVDD1 = SPKVDD2.
- DBVDD = DBVDD1 = DBVDD2 = DBVDD3.
- $I_{SPKVDD} = I_{SPKVDD1} + I_{SPKVDD2}$.
- $I_{DBVDD} = I_{DBVDD1} + I_{DBVDD2} + I_{DBVDD3}$.
- Power consumption for music playback with LDOs disabled requires an external supply for AVDD1 and DCVDD

TYPICAL SIGNAL LATENCY

OPERATING MODE	TEST CONDITIONS			LATENCY
	AIF1	AIF2	DIGITAL CORE	
AIF2 to DAC Stereo Path				
AIF2 EQ enabled, AIF2 3D enabled, AIF2 DRC enabled, SRC enabled	fs=8kHz, Clock rate = 256fs	fs=8kHz, Clock rate = 1536fs	SYSCLK=AIF1CLK	1.4ms
	fs=48kHz, Clock rate = 256fs	fs=8kHz, Clock rate = 1536fs	SYSCLK=AIF1CLK	1.3ms
	fs=8kHz, Clock rate = 256fs	fs=8kHz, Clock rate = 256fs	SYSCLK=AIF1CLK	1.7ms
	fs=48kHz, Clock rate = 256fs	fs=8kHz, Clock rate = 256fs	SYSCLK=AIF1CLK	1.4ms
ADC to AIF2 Stereo Path				
Digital Sidetone HPF enabled, AIF2 DRC enabled, AIF2 HPF enabled, SRC enabled	fs=8kHz, Clock rate = 256fs	fs=8kHz, Clock rate = 256fs	SYSCLK=AIF1CLK	2.2ms
	fs=48kHz, Clock rate = 256fs	fs=8kHz, Clock rate = 256fs	SYSCLK=AIF1CLK	1.2ms
Digital Sidetone HPF disabled, AIF2 DRC disabled, AIF2 HPF disabled, SRC disabled		fs=8kHz, Clock rate = 1536fs	SYSCLK=AIF2CLK	1.3ms
Digital Sidetone HPF disabled, AIF2 DRC disabled, AIF2 HPF disabled, SRC enabled	fs=48kHz, Clock rate = 256fs	fs=8kHz, Clock rate = 1536fs	SYSCLK=AIF1CLK	1.1ms

Notes:

1. These figures are relevant to typical voice call modes, assuming AIF2 is connected to the baseband processor
2. The SRC (Sample Rate Converter) is enabled automatically whenever required

SPEAKER DRIVER PERFORMANCE

Typical speaker driver THD+N performance is shown below for Class D and Class AB modes. Curves are shown for typical SPKVDD supply voltage, gain and load conditions.

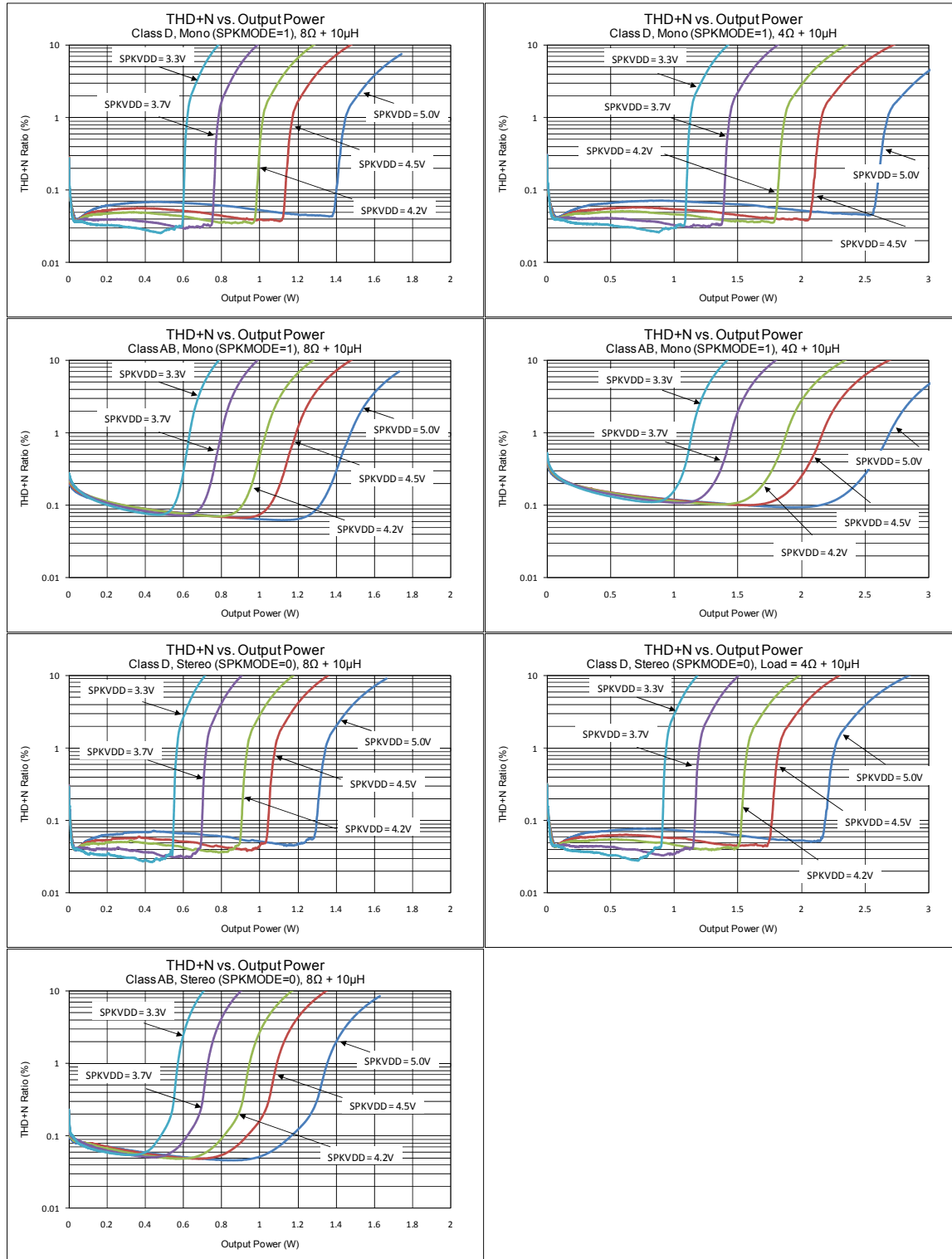

SIGNAL TIMING REQUIREMENTS

SYSTEM CLOCKS & FREQUENCY LOCKED LOOP (FLL)

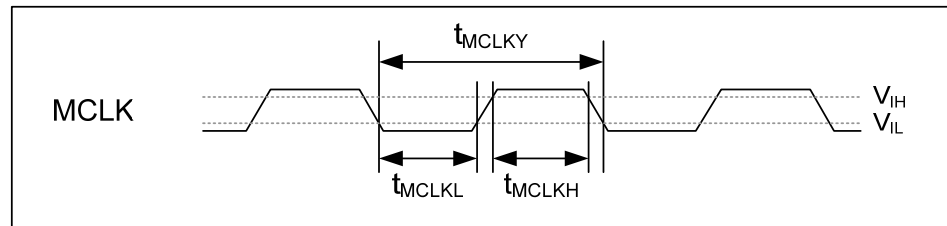

Figure 2 Master Clock Timing

Test Conditions

The following timing information is valid across the full range of recommended operating conditions.

PARAMETER	SYMBOL	CONDITIONS	MIN	TYP	MAX	UNIT
Master Clock Timing (MCLK1 and MCLK2)						
MCLK cycle time	T_{MCLKY}	MCLK as input to FLL, FLLn_REFCLK_DIV = 01, 10, 11	37			ns
		MCLK as input to FLL, FLLn_REFCLK_DIV = 00	74			
		FLL not used, AIFnCLK_DIV = 1	40			
		FLL not used, AIFnCLK_DIV = 0	80			
MCLK duty cycle (= $T_{MCLKH} : T_{MCLKL}$)			60:40		40:60	
Frequency Locked Loops (FLL1 and FLL2)						
FLL Input Frequency		FLLn_REFCLK_DIV = 00	0.032		13.5	MHz
		FLLn_REFCLK_DIV = 01	0.064		27	
		FLLn_REFCLK_DIV = 10	0.128		27	
		FLLn_REFCLK_DIV = 11	0.256		27	
Internal Clocking						
SYSClk frequency					12.5	MHz
AIF1CLK frequency					12.5	MHz
AIF2CLK frequency					12.5	MHz
DSP2CLK frequency					25	MHz

AUDIO INTERFACE TIMING

DIGITAL MICROPHONE (DMIC) INTERFACE TIMING

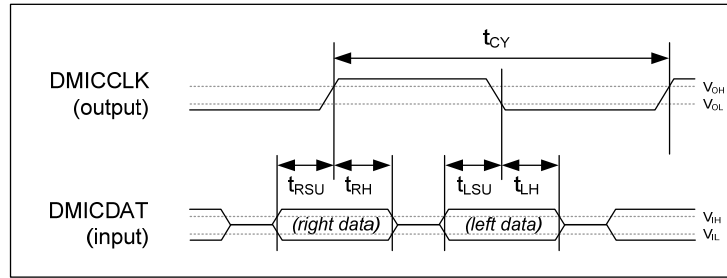

Figure 3 Digital Microphone Interface Timing

Test Conditions

The following timing information is valid across the full range of recommended operating conditions.

PARAMETER	SYMBOL	MIN	TYP	MAX	UNIT
Digital Microphone Interface Timing					
DMICCLK cycle time	t_{CY}	320			ns
DMICCLK duty cycle		45:55		55:45	%
DMICDAT (Left) setup time to falling DMICCLK edge	t_{LSU}	15			ns
DMICDAT (Left) hold time from falling DMICCLK edge	t_{LH}	0			ns
DMICDAT (Right) setup time to rising DMICCLK edge	t_{RSU}	15			ns
DMICDAT (Right) hold time from rising DMICCLK edge	t_{RH}	0			ns

DIGITAL AUDIO INTERFACE - MASTER MODE

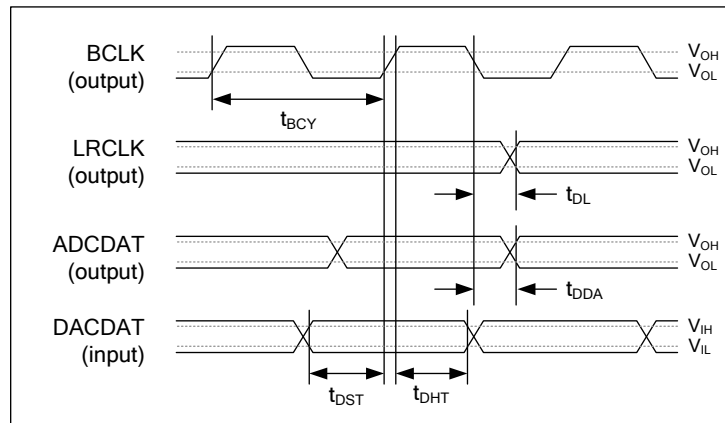

Figure 4 Audio Interface Timing - Master Mode

Note that BCLK and LRCLK outputs can be inverted if required; Figure 4 shows the default, non-inverted polarity of these signals.

Test Conditions

The following timing information is valid across the full range of recommended operating conditions.

PARAMETER	SYMBOL	MIN	TYP	MAX	UNIT
Audio Interface Timing - Master Mode					
BCLK cycle time	t_{BCY}	160			ns
LRCLK propagation delay from BCLK falling edge	t_{DL}			20	ns
ADCDAT propagation delay from BCLK falling edge	t_{DDA}			48	ns
DACDAT setup time to BCLK rising edge	t_{DST}	32			ns
DACDAT hold time from BCLK rising edge	t_{DHT}	10			ns
Audio Interface Timing - Ultrasonic (4FS) Master Mode					
BCLK cycle time	t_{BCY}	80			ns
ADCDAT propagation delay from BCLK falling edge	t_{DDA}			24	ns

Note that the descriptions above assume non-inverted polarity of BCLK and LRCLK.

DIGITAL AUDIO INTERFACE - SLAVE MODE

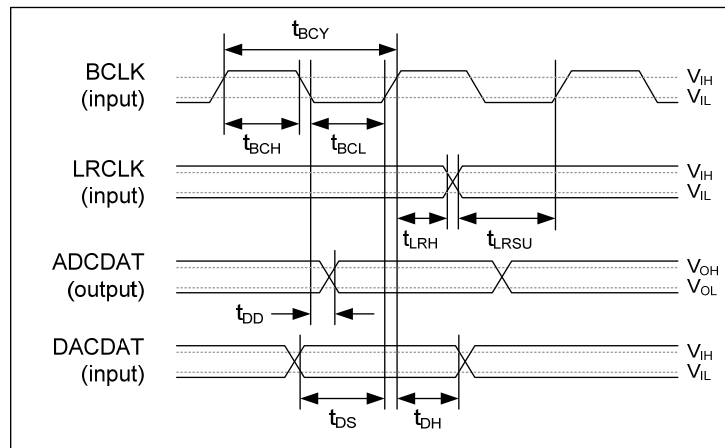

Figure 5 Audio Interface Timing - Slave Mode

Note that BCLK and LRCLK inputs can be inverted if required; Figure 5 shows the default, non-inverted polarity.

Test Conditions

The following timing information is valid across the full range of recommended operating conditions.

PARAMETER	SYMBOL	MIN	TYP	MAX	UNIT
Audio Interface Timing - Slave Mode					
BCLK cycle time	t_{BCY}	160			ns
BCLK pulse width high	t_{BCH}	64			ns
BCLK pulse width low	t_{BCL}	64			ns
LRCLK set-up time to BCLK rising edge	t_{LRH}	10			ns
LRCLK hold time from BCLK rising edge	t_{LRSU}	10			ns
DACDAT hold time from BCLK rising edge	t_{DH}	10			ns
ADCDAT propagation delay from BCLK falling edge	t_{DD}			48	ns
DACDAT set-up time to BCLK rising edge	t_{DS}	32			ns

Note that the descriptions above assume non-inverted polarity of BCLK and LRCLK.

DIGITAL AUDIO INTERFACE - TDM MODE

When TDM operation is used on the ADCDATn pins, it is important that two devices do not attempt to drive the ADCDATn pin simultaneously. To support this requirement, the ADCDATn pins can be configured to be tri-stated when not outputting data.

The timing of the WM8958 ADCDATn tri-stating at the start and end of the data transmission is described in Figure 6 below.

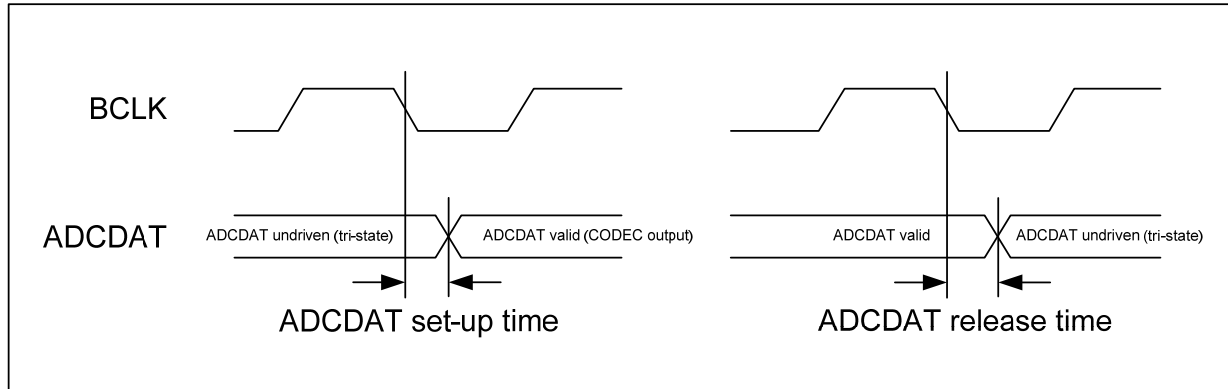

Figure 6 Audio Interface Timing - TDM Mode

Test Conditions

The following timing information is valid across the full range of recommended operating conditions.

PARAMETER	MIN	TYP	MAX	UNIT
TDM Timing - Master Mode				
ADCDAT setup time from BCLK falling edge	0			ns
ADCDAT release time from BCLK falling edge			15	ns
TDM Timing - Slave Mode				
ADCDAT setup time from BCLK falling edge	5			ns
ADCDAT release time from BCLK falling edge			32	ns

CONTROL INTERFACE TIMING

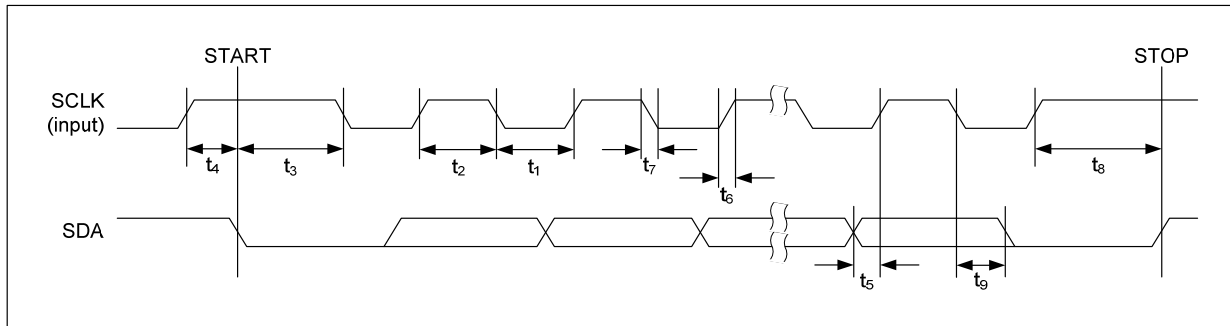

Figure 7 Control Interface Timing

Test Conditions

The following timing information is valid across the full range of recommended operating conditions.

PARAMETER	SYMBOL	MIN	TYP	MAX	UNIT
SCLK Frequency				400	kHz
SCLK Low Pulse-Width	t_1	1300			ns
SCLK High Pulse-Width	t_2	600			ns
Hold Time (Start Condition)	t_3	600			ns
Setup Time (Start Condition)	t_4	600			ns
Data Setup Time	t_5	100			ns
SDA, SCLK Rise Time	t_6			300	ns
SDA, SCLK Fall Time	t_7			300	ns
Setup Time (Stop Condition)	t_8	600			ns
Data Hold Time	t_9			900	ns
Pulse width of spikes that will be suppressed	t_{ps}	0		5	ns

DEVICE DESCRIPTION

INTRODUCTION

The WM8958 is a low power, high quality audio codec designed to interface with a wide range of processors and analogue components. A high level of mixed-signal integration in a very small footprint makes it ideal for portable applications such as mobile phones. Fully differential internal architecture and on-chip RF noise filters ensure a very high degree of noise immunity.

Three sets of audio interface pins are available in order to provide independent and fully asynchronous connections to multiple processors, typically an application processor, baseband processor and wireless transceiver. Any two of these interfaces can operate totally independently and asynchronously while the third interface can be synchronised to either of the other two and can also provide ultra low power loopback modes to support, for example, wireless headset voice calls.

Four digital microphone input channels are available to support advanced multi-microphone applications such as noise cancellation. An integrated microphone activity monitor is available to enable the processor to sleep during periods of microphone inactivity, saving power.

Four DAC channels are available to support use cases requiring up to four simultaneous digital audio streams to the output drivers.

Eight highly flexible analogue inputs allow interfacing to up to four microphone inputs (single-ended or differential), plus multiple stereo or mono line inputs. Connections to an external voice CODEC, FM radio, line input, handset MIC and headset MIC are all fully supported. Signal routing to the output mixers and within the CODEC has been designed for maximum flexibility to support a wide variety of usage modes. A 'Direct Voice' path from a voice CODEC directly to the Speaker or Earpiece output drivers is included.

Impedance sensing and measurement for external accessories is provided, for detection of the insertion or removal of microphones and other accessories. Push-button detection of up to 7 inputs can be supported using this feature.

Nine analogue output drivers are integrated, including a stereo pair of high power, high quality Class D/AB switchable speaker drivers; these can support 2W each in stereo mode. It is also possible to configure the speaker drivers as a mono output, giving enhanced performance. A mono earpiece driver is provided, providing output from the output mixers or from the low-power differential 'Direct Voice' path.

One pair of ground-referenced headphone outputs is provided; these are powered from an integrated Charge Pump, enabling high quality, power efficient headphone playback without any requirement for DC blocking capacitors. A DC Servo circuit is available for DC offset correction, thereby suppressing pops and reducing power consumption. Four line outputs are provided, with multiple configuration options including 4 x single-ended outputs or 2 x differential outputs. The line outputs are suitable for output to a voice CODEC, an external speaker driver or line output connector. Ground loop feedback is available on the headphone outputs and the line outputs, providing rejection of noise on the ground connections. All outputs have integrated pop and click suppression features.

Internal differential signal routing and amplifier configurations have been optimised to provide the highest performance and lowest possible power consumption for a wide range of usage scenarios, including voice calls and music playback. The speaker drivers offer low leakage and high PSRR; this enables direct connection to a Lithium battery. The speaker drivers provide eight levels of AC and DC gain to allow output signal levels to be maximised for many commonly-used SPKVDD/AVDD1 combinations.

The ADCs and DACs are of hi-fi quality, using a 24-bit low-order oversampling architecture to deliver optimum performance. A flexible clocking arrangement supports mixed sample rates, whilst integrated ultra-low power dual FLLs provide additional flexibility. A high pass filter is available in all ADC and digital MIC paths for removing DC offsets and suppressing low frequency noise such as mechanical vibration and wind noise. A digital mixing path from the ADC or digital MICs to the DAC provides a sidetone of enhanced quality during voice calls. DAC soft mute and un-mute is available for pop-free music playback.

The integrated Multiband Compressors (MBC), Dynamic Range Controllers (DRC) and ReTune™ Mobile 5-band parametric equaliser (EQ) provide further processing capability of the digital audio paths. The MBC enables the loudness of the digital playback path to be maximised without overdriving the loudspeakers. The RMS Limiter within the MBC function enables the maximum signal level to be matched to the application requirements and/or power rating of the loudspeaker. The DRC provides compression and signal level control to improve the handling of unpredictable signal levels. 'Anti-clip' and 'quick release' algorithms improve intelligibility in the presence of transients and impulsive noises. The EQ provides the capability to tailor the audio path according to the frequency characteristics of an earpiece or loudspeaker, and/or according to user preferences.

The WM8958 has highly flexible digital audio interfaces, supporting a number of protocols, including I²S, DSP, MSB-first left/right justified, and can operate in master or slave modes. PCM operation is supported in the DSP mode. A-law and μ -law companding are also supported. Time division multiplexing (TDM) is available to allow multiple devices to stream data simultaneously on the same bus, saving space and power. The four digital MIC and ADC channels and four DAC channels are available via four TDM channels on Digital Audio Interface 1 (AIF1).

A powerful digital mixing core allows data from each TDM channel of each audio interface and from the ADCs and digital MICs to be mixed and re-routed back to a different audio interface and to the 4 DAC output channels. The digital mixing core can operate synchronously with either Audio Interface 1 or Audio Interface 2, with asynchronous stereo full duplex sample rate conversion performed on the other audio interface as required.

The system clock (SYSCLK) provides clocking for the ADCs, DACs, DSP core, digital audio interface and other circuits. SYSCLK can be derived directly from one of the MCLK1 or MCLK2 pins or via one of two integrated FLLs, providing flexibility to support a wide range of clocking schemes, including self-clocking FLL modes. Typical portable system MCLK frequencies, and sample rates from 8kHz to 96kHz are all supported. A low frequency (eg. 32.768kHz) clock can be used as the input reference to the FLLs, providing further flexibility. Automatic configuration of the clocking circuits is available, derived from the sample rate and from the MCLK / SYSCLK ratio.

The WM8958 uses a standard 2-wire control interface, providing full software control of all features, together with device register readback. An integrated Control Write Sequencer enables automatic scheduling of control sequences; commonly-used signal configurations may be selected using ready-programmed sequences, including time-optimised control of the WM8958 pop suppression features. It is an ideal partner for a wide range of industry standard microprocessors, controllers and DSPs. Unused circuitry can be disabled under software control, in order to save power; low leakage currents enable extended standby/off time in portable battery-powered applications.

Versatile GPIO functionality is provided, with support for button/accessory detect inputs, or for clock, system status, or programmable logic level output for control of additional external circuitry. Interrupt logic, status readback and de-bouncing options are supported within this functionality.

ANALOGUE INPUT SIGNAL PATH

The WM8958 has eight highly flexible analogue input channels, configurable in a large number of combinations:

1. Up to four fully differential or single-ended microphone inputs
2. Up to eight mono line inputs or 4 stereo line inputs
3. A dedicated mono differential input from external voice CODEC

These inputs may be mixed together or independently routed to different combinations of output drivers. An internal record path is provided at the input mixers to allow DAC output to be mixed with the input signal path (e.g. for voice call recording).

The WM8958 input signal paths and control registers are illustrated in Figure 8.

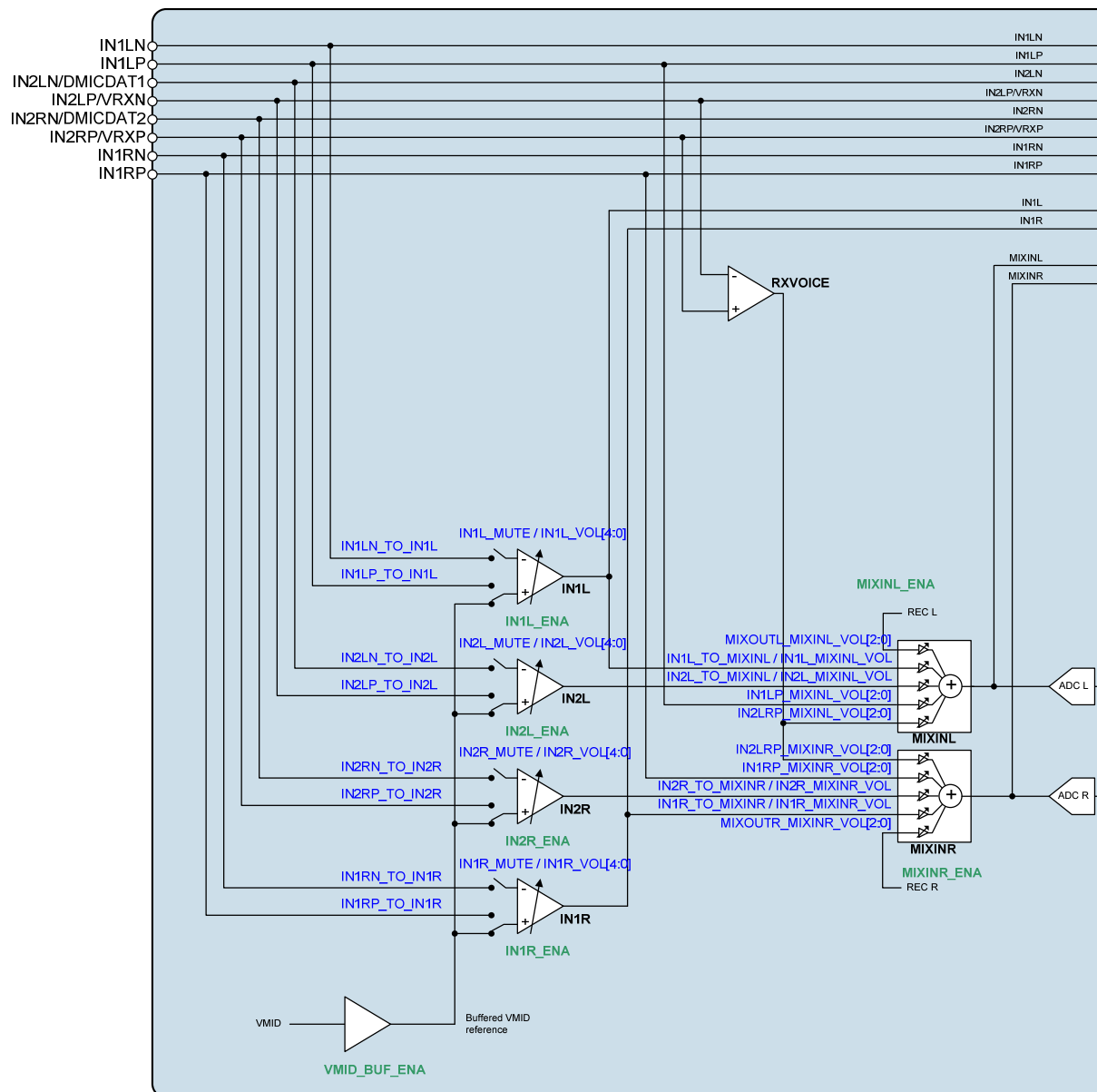

Figure 8 Control Registers for Input Signal Path

MICROPHONE INPUTS

Up to four analogue microphones can be connected to the WM8958, either in single-ended or differential mode. A dedicated PGA is provided for each microphone input. Two low noise microphone bias circuits are provided, reducing the need for external components.

For single-ended microphone inputs, the microphone signal is connected to the inverting input of the PGAs (IN1LN, IN2LN, IN1RN or IN2RN). The non-inverting inputs of the PGAs are internally connected to VMID in this configuration. The non-inverting input pins IN1LP, IN2LP, IN1RP and IN2RP are free to be used as line connections to the input or output mixers in this configuration.

For differential microphone inputs, the non-inverted microphone signal is connected to the non-inverting input of the PGAs (IN1LP, IN2LP, IN1RP or IN2RP), whilst the inverted (or 'noisy ground') signal is connected to the inverting input pins (IN1LN, IN2LN, IN1RN and IN2RN).

The gain of the input PGAs is controlled via register settings, as defined in Table 4. Note that the input impedance of both inverting and non-inverting inputs changes with the input PGA gain setting, as described under "Electrical Characteristics". See also the "Applications Information" for details of input resistance at all PGA Gain settings.

The microphone input configurations are illustrated in Figure 9 and Figure 10. Note that any PGA input pin that is used in either microphone configuration is not available for use as a line input path at the same time.

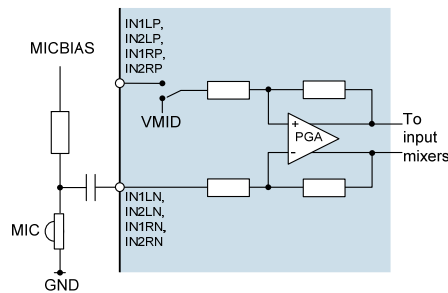

Figure 9 Single-Ended Microphone Input

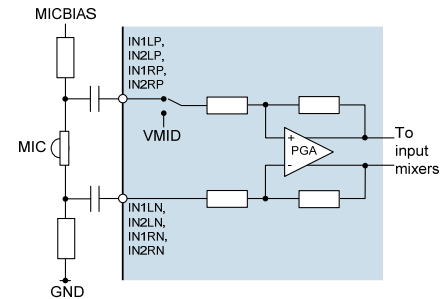

Figure 10 Differential Microphone Input

MICROPHONE BIAS CONTROL

There are two MICBIAS generators which provide low noise reference voltages suitable for powering silicon (MEMS) microphones or biasing electret condenser (ECM) type microphones via an external resistor. Refer to the "Applications Information" section for recommended external components.

The MICBIAS outputs can be independently enabled using the MICB1_ENA and MICB2_ENA register bits. Under default conditions, a smooth pop-free profile of the MICBIAS outputs is implemented when MICB1_ENA or MICB2_ENA is enabled or disabled; a faster transition can be selected by setting the MICB1_RATE and MICB2_RATE registers as described in Table 1.

When a MICBIAS output is disabled, the output pin can be configured to be floating or to be actively discharged. This is selected using the MICB1_DISCH and MICB2_DISCH register bits.

The MICBIAS generators can each operate as a voltage regulator or in bypass mode.

In Regulator mode, the output voltage is selected using the MICB1_LVL and MICB2_LVL register bits. In this mode, AVDD1 must be at least 200mV greater than the required MICBIAS output voltages. The MICBIAS outputs are powered from the AVDD1 supply pin, and use the internal bandgap circuit as a reference.

Note that, in Regulator mode, the MICBIAS regulators are designed to operate without external decoupling capacitors. It is important that parasitic capacitances on the MICBIAS1 or MICBIAS2 pins do not exceed the specified limit in Regulator mode (see "Electrical Characteristics").

In Bypass mode, the output pin (MICBIAS1 or MICBIAS2) is connected directly to AVDD1. This enables a low power operating state. Note that, if a capacitive load is connected to MICBIAS1 or MICBIAS2 (eg. for a digital microphone supply), then the respective MICBIAS generator must be configured in Bypass mode.

The MICBIAS configuration is illustrated in Figure 11.

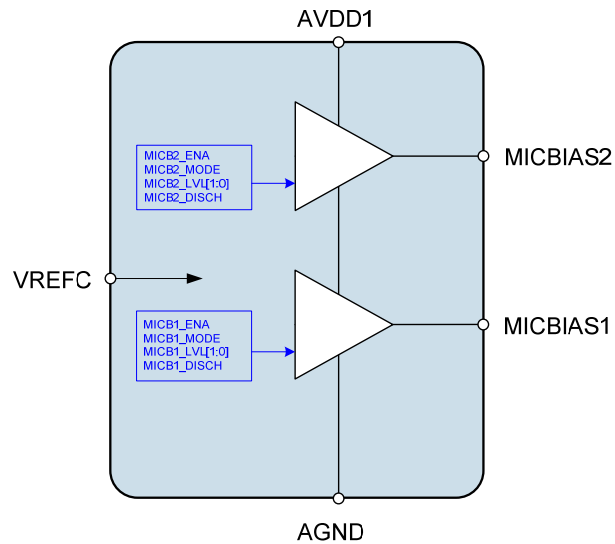

Figure 11 MICBIAS Generator

REGISTER ADDRESS	BIT	LABEL	DEFAULT	DESCRIPTION
R1 (0001h) Power Management (1)	5	MICB2_ENA	0	Microphone Bias 2 Enable 0 = Disabled 1 = Enabled
	4	MICB1_ENA	0	Microphone Bias 1 Enable 0 = Disabled 1 = Enabled
R61 (003Dh) MICBIAS 1	5	MICB1_RATE	1	Microphone Bias 1 Rate 0 = Fast start-up / shut-down 1 = Pop-free start-up / shut-down
	4	MICB1_MODE	1	Microphone Bias 1 Mode 0 = Regulator mode 1 = Bypass mode
	3:1	MICB1_LVL [2:0]	100	Microphone Bias 1 Voltage Control (when MICB1_MODE = 0) 000 = 1.5V 001 = 1.8V 010 = 1.9V 011 = 2.0V 100 = 2.2V 101 = 2.4V 110 = 2.5V 111 = 2.6V
	0	MICB1_DISCH	1	Microphone Bias 1 Discharge 0 = MICBIAS1 floating when disabled 1 = MICBIAS1 discharged when disabled
R62 (003Eh) MICBIAS 2	5	MICB2_RATE	1	Microphone Bias 2 Rate 0 = Fast start-up / shut-down 1 = Pop-free start-up / shut-down
	4	MICB2_MODE	1	Microphone Bias 2 Mode 0 = Regulator mode 1 = Bypass mode

REGISTER ADDRESS	BIT	LABEL	DEFAULT	DESCRIPTION
	3:1	MICB2_LVL [2:0]	100	Microphone Bias 2 Voltage Control (when MICB2_MODE = 0) 000 = 1.5V 001 = 1.8V 010 = 1.9V 011 = 2.0V 100 = 2.2V 101 = 2.4V 110 = 2.5V 111 = 2.6V
	0	MICB2_DISCH	1	Microphone Bias 2 Discharge 0 = MICBIAS2 floating when disabled 1 = MICBIAS2 discharged when disabled

Table 1 Microphone Bias Control

Note that the maximum source current capability for MICBIAS1 and MICBIAS2 is 2.4mA each in Regulator mode. The external biasing resistance must be large enough to limit each MICBIAS current to 2.4mA across the full microphone impedance range. The maximum source current for MICBIAS1 and MICBIAS2 is 3.6mA each in Bypass mode, as described in the “Electrical Characteristics”.

MICROPHONE ACCESSORY DETECT

The WM8958 provides a microphone detection function, which uses impedance measurement to detect one or more different external accessory connections. This feature is described in the “External Accessory Detection” section.

LINE AND VOICE CODEC INPUTS

All eight analogue input pins may be used as line inputs. Each line input has different signal path options, providing flexibility, high performance and low power consumption for many different usage modes.

IN1LN and IN1RN can operate as single-ended line inputs to the input PGAs IN1L and IN1R respectively. These inputs provide a high gain path if required for low input signal levels.

IN2LN and IN2RN can operate as single-ended line inputs to the input PGAs IN2L and IN2R respectively, providing further high gain signal paths. These pins can also be connected to either of the output mixers MIXOUTL and MIXOUTR.

IN1LP and IN1RP can operate as single-ended line inputs to the input mixers MIXINL and MIXINR, or to the speaker mixers SPKMIXL and SPKMIXR. These signal paths enable power consumption to be reduced, by allowing the input PGAs and other circuits to be disabled if not required.

IN2LP/VRXN and IN2RP/VRXP can operate in three different ways:

- Mono differential ‘RXVOICE’ input (e.g. from an external voice CODEC) to the input mixers MIXINL and MIXINR.
- Single-ended line inputs to either of the output mixers MIXOUTL and MIXOUTR.
- Ultra-low power mono differential ‘Direct Voice’ input (e.g. from an external voice CODEC) to the ear speaker driver on HPOUT2, or to either of the speaker drivers on SPKOUTL and SPKOUTR.

Signal path configuration to the input PGAs and input mixers is detailed later in this section. Signal path configuration to the output mixers and speaker mixers is described in “Analogue Output Signal Path”.

The line input and voice CODEC input configurations are illustrated in Figure 12 through to Figure 15.

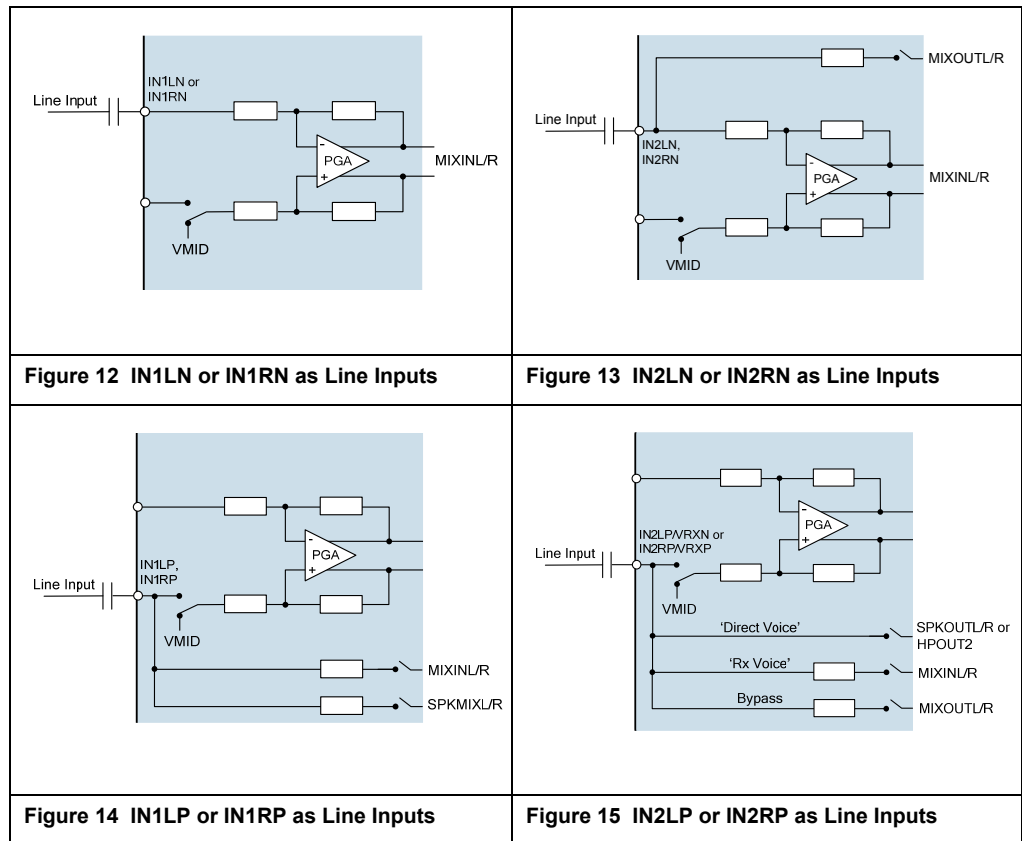

INPUT PGA ENABLE

The Input PGAs are enabled using register bits IN1L_ENA, IN2L_ENA, IN1R_ENA and IN2R_ENA, as described in Table 2. The Input PGAs must be enabled for microphone input on the respective input pins, or for line input on the inverting input pins IN1LN, IN1RN, IN2LN, IN2RN.

REGISTER ADDRESS	BIT	LABEL	DEFAULT	DESCRIPTION
R2 (0002h) Power Management (2)	7	IN2L_ENA	0	IN2L Input PGA Enable 0 = Disabled 1 = Enabled
	6	IN1L_ENA	0	IN1L Input PGA Enable 0 = Disabled 1 = Enabled
	5	IN2R_ENA	0	IN2R Input PGA Enable 0 = Disabled 1 = Enabled
	4	IN1R_ENA	0	IN1R Input PGA Enable 0 = Disabled 1 = Enabled

Table 2 Input PGA Enable

For normal operation of the input PGAs, the reference voltage VMID and the bias current must also be enabled. See "Reference Voltages and Master Bias" for details of the associated controls VMID_SEL and BIAS_ENA.

INPUT PGA CONFIGURATION

Each of the Input PGAs can operate in a single-ended or differential mode. In differential mode, both inputs to the PGA are connected to the input source. In single-ended mode, the non-inverting input to the PGA must be connected to VMID. Configuration of the PGA inputs to the WM8958 input pins is controlled using the register bits shown in Table 3.

Single-ended microphone operation is configured by connecting the input source to the inverting input of the applicable PGA. The non-inverting input of the PGA must be connected to the buffered VMID reference. Note that the buffered VMID reference must be enabled, using the VMID_BUF_ENA register, as described in "Reference Voltages and Master Bias".

Differential microphone operation is configured by connecting the input source to both inputs of the applicable PGA.

Line inputs to the input pins IN1LN, IN2LN, IN1RN and IN2RN must be connected to the applicable PGA. The non-inverting input of the PGA must be connected to VMID.

Line inputs to the input pins IN1LP, IN2LP, IN1RP or IN2RP do not connect to the input PGAs. The non-inverting inputs of the associated PGAs must be connected to VMID. The inverting inputs of the associated PGAs may be used as separate mic/line inputs if required.

The maximum available attenuation on any of these input paths is achieved by using register bits shown in Table 3 to disconnect the input pins from the applicable PGA.

REGISTER ADDRESS	BIT	LABEL	DEFAULT	DESCRIPTION
R40 (0028h) Input Mixer (2)	7	IN2LP_TO_IN2L	0	IN2L PGA Non-Inverting Input Select 0 = Connected to VMID 1 = Connected to IN2LP Note that VMID_BUF_ENA must be set when using IN2L connected to VMID.
	6	IN2LN_TO_IN2L	0	IN2L PGA Inverting Input Select 0 = Not connected 1 = Connected to IN2LN
	5	IN1LP_TO_IN1L	0	IN1L PGA Non-Inverting Input Select 0 = Connected to VMID 1 = Connected to IN1LP Note that VMID_BUF_ENA must be set when using IN1L connected to VMID.
	4	IN1LN_TO_IN1L	0	IN1L PGA Inverting Input Select 0 = Not connected 1 = Connected to IN1LN
	3	IN2RP_TO_IN2R	0	IN2R PGA Non-Inverting Input Select 0 = Connected to VMID 1 = Connected to IN2RP Note that VMID_BUF_ENA must be set when using IN2R connected to VMID.
	2	IN2RN_TO_IN2R	0	IN2R PGA Inverting Input Select 0 = Not connected 1 = Connected to IN2RN
	1	IN1RP_TO_IN1R	0	IN1R PGA Non-Inverting Input Select 0 = Connected to VMID 1 = Connected to IN1RP Note that VMID_BUF_ENA must be set when using IN1R connected to VMID.
	0	IN1RN_TO_IN1R	0	IN1R PGA Inverting Input Select 0 = Not connected 1 = Connected to IN1RN

Table 3 Input PGA Configuration

INPUT PGA VOLUME CONTROL

Each of the four Input PGAs has an independently controlled gain range of -16.5dB to +30dB in 1.5dB steps. The gains on the inverting and non-inverting inputs to the PGAs are always equal. Each Input PGA can be independently muted using the PGA mute bits as described in Table 4, with maximum mute attenuation achieved by simultaneously disconnecting the corresponding inputs described in Table 3.

Note that, under default conditions (following power-up or software reset), the PGA mute register bits are set to '1', but the mute functions will only become effective after the respective bit has been toggled to '0' and then back to '1'. The Input PGAs will be un-muted (Mute disabled) after power-up or software reset, regardless of the readback value of the respective PGA mute bits.

To prevent "zipper noise", a zero-cross function is provided on the input PGAs. When this feature is enabled, volume updates will not take place until a zero-crossing is detected. In the case of a long period without zero-crossings, a timeout function is provided. When the zero-cross function is enabled, the volume will update after the timeout period if no earlier zero-cross has occurred. The timeout clock is enabled using TOCLK_ENA, the timeout period is set by TOCLK_DIV. See "Clocking and Sample Rates" for more information on these fields.

The IN1_VU and IN2_VU bits control the loading of the input PGA volume data. When IN1_VU and IN2_VU are set to 0, the PGA volume data will be loaded into the respective control register, but will not actually change the gain setting. The IN1L and IN1R volume settings are both updated when a 1 is written to IN1_VU; the IN2L and IN2R volume settings are both updated when a 1 is written to IN2_VU. This makes it possible to update the gain of the left and right signal paths simultaneously.

The Input PGA Volume Control register fields are described in Table 4 and Table 5.

REGISTER ADDRESS	BIT	LABEL	DEFAULT	DESCRIPTION
R24 (0018h) Left Line Input 1&2 Volume	8	IN1_VU	N/A	Input PGA Volume Update Writing a 1 to this bit will cause IN1L and IN1R input PGA volumes to be updated simultaneously
	7	IN1L_MUTE	1	IN1L PGA Mute 0 = Disable Mute 1 = Enable Mute
	6	IN1L_ZC	0	IN1L PGA Zero Cross Detector 0 = Change gain immediately 1 = Change gain on zero cross only
	4:0	IN1L_VOL [4:0]	01011 (0dB)	IN1L Volume -16.5dB to +30dB in 1.5dB steps (See Table 5 for volume range)
R25 (0019h) Left Line Input 3&4 Volume	8	IN2_VU	N/A	Input PGA Volume Update Writing a 1 to this bit will cause IN2L and IN2R input PGA volumes to be updated simultaneously
	7	IN2L_MUTE	1	IN2L PGA Mute 0 = Disable Mute 1 = Enable Mute
	6	IN2L_ZC	0	IN2L PGA Zero Cross Detector 0 = Change gain immediately 1 = Change gain on zero cross only
	4:0	IN2L_VOL [4:0]	01011 (0dB)	IN2L Volume -16.5dB to +30dB in 1.5dB steps (See Table 5 for volume range)
R26 (001Ah) Right Line Input 1&2 Volume	8	IN1_VU	N/A	Input PGA Volume Update Writing a 1 to this bit will cause IN1L and IN1R input PGA volumes to be updated simultaneously
	7	IN1R_MUTE	1	IN1R PGA Mute 0 = Disable Mute 1 = Enable Mute
	6	IN1R_ZC	0	IN1R PGA Zero Cross Detector 0 = Change gain immediately 1 = Change gain on zero cross only
	4:0	IN1R_VOL [4:0]	01011 (0dB)	IN1R Volume -16.5dB to +30dB in 1.5dB steps (See Table 5 for volume range)
R27 (001Bh) Right Line Input 3&4 Volume	8	IN2_VU	N/A	Input PGA Volume Update Writing a 1 to this bit will cause IN2L and IN2R input PGA volumes to be updated simultaneously
	7	IN2R_MUTE	1	IN2R PGA Mute 0 = Disable Mute 1 = Enable Mute
	6	IN2R_ZC	0	IN2R PGA Zero Cross Detector 0 = Change gain immediately 1 = Change gain on zero cross only
	4:0	IN2R_VOL [4:0]	01011 (0dB)	IN2R Volume -16.5dB to +30dB in 1.5dB steps (See Table 5 for volume range)

Table 4 Input PGA Volume Control

IN1L_VOL[4:0], IN2L_VOL[4:0], IN1R_VOL[4:0], IN2R_VOL[4:0]	VOLUME (dB)
00000	-16.5
00001	-15.0
00010	-13.5
00011	-12.0
00100	-10.5
00101	-9.0
00110	-7.5
00111	-6.0
01000	-4.5
01001	-3.0
01010	-1.5
01011	0
01100	+1.5
01101	+3.0
01110	+4.5
01111	+6.0
10000	+7.5
10001	+9.0
10010	+10.5
10011	+12.0
10100	+13.5
10101	+15.0
10110	+16.5
10111	+18.0
11000	+19.5
11001	+21.0
11010	+22.5
11011	+24.0
11100	+25.5
11101	+27.0
11110	+28.5
11111	+30.0

Table 5 Input PGA Volume Range

INPUT MIXER ENABLE

The WM8958 has two analogue input mixers which allow the Input PGAs and Line Inputs to be combined in a number of ways and output to the ADCs, Output Mixers, or directly to the output drivers via bypass paths.

The input mixers MIXINL and MIXINR are enabled by the MIXINL_ENA and MIXINR_ENA register bits, as described in Table 6. These control bits also enable the RXVOICE input path, described in the following section.

For normal operation of the input mixers, the reference voltage VMID and the bias current must also be enabled. See "Reference Voltages and Master Bias" for details of the associated controls VMID_SEL and BIAS_ENA.

REGISTER ADDRESS	BIT	LABEL	DEFAULT	DESCRIPTION
R2 (0002h) Power Management (2)	9	MIXINL_ENA	0	Left Input Mixer Enable (Enables MIXINL and RXVOICE input to MIXINL) 0 = Disabled 1 = Enabled
	8	MIXINR_ENA	0	Right Input Mixer Enable (Enables MIXINR and RXVOICE input to MIXINR) 0 = Disabled 1 = Enabled

Table 6 Input Mixer Enable

INPUT MIXER CONFIGURATION AND VOLUME CONTROL

The left and right channel input mixers MIXINL and MIXINR can be configured to take input from up to five sources:

1. IN1L or IN1R Input PGA
2. IN2L or IN2R Input PGA
3. IN1LP or IN1RP pin (PGA bypass)
4. RXVOICE mono differential input from IN2LP/VRXN and IN2RP/VRXP
5. MIXOUTL or MIXOUTR Output Mixer (Record path)

The Input Mixer configuration and volume controls are described in Table 7 for the Left input mixer (MIXINL) and Table 8 for the Right input mixer (MIXINR). The signal levels from the Input PGAs may be set to Mute, 0dB or 30dB boost. Gain controls for the PGA bypass, RXVOICE and Record paths provide adjustment from -12dB to +6dB in 3dB steps.

When using the IN1LP or IN1RP signal paths direct to the input mixers (PGA bypass paths), a signal gain of +15dB can be selected using the IN1RP_MIXINR_BOOST or IN1LP_MIXINL_BOOST register bits. See Table 7 and Table 8 for further details.

When using the IN1LP or IN1RP signal paths direct to the input mixers (PGA bypass paths), the buffered VMID reference must be enabled, using the VMID_BUF_ENA register, as described in "Reference Voltages and Master Bias".

To prevent pop noise, it is recommended that gain and mute controls for the input mixers are not modified while the signal paths are active. If volume control is required on these signal paths, it is recommended that this is implemented using the input PGA volume controls or the ADC volume controls. The ADC volume controls are described in the "Analogue to Digital Converter (ADC)" section.

REGISTER ADDRESS	BIT	LABEL	DEFAULT	DESCRIPTION
R21 (0015h) Input Mixer (1)	7	IN1LP_MIXINL_BOOST	0	IN1LP Pin (PGA Bypass) to MIXINL Gain Boost. This bit selects the maximum gain setting of the IN1LP_MIXINL_VOL register. 0 = Maximum gain is +6dB 1 = Maximum gain is +15dB
R41 (0029h) Input Mixer (3)	8	IN2L_TO_MIXINL	0	IN2L PGA Output to MIXINL Mute 0 = Mute 1 = Un-Mute
	7	IN2L_MIXINL_VOL	0	IN2L PGA Output to MIXINL Gain 0 = 0dB 1 = +30dB
	5	IN1L_TO_MIXINL	0	IN1L PGA Output to MIXINL Mute 0 = Mute 1 = Un-Mute
	4	IN1L_MIXINL_VOL	0	IN1L PGA Output to MIXINL Gain 0 = 0dB 1 = +30dB
	2:0	MIXOUTL_MIXINL_VOL [2:0]	000 (Mute)	Record Path MIXOUTL to MIXINL Gain and Mute 000 = Mute 001 = -12dB 010 = -9dB 011 = -6dB 100 = -3dB 101 = 0dB 110 = +3dB 111 = +6dB
R43 (002Bh) Input Mixer (5)	8:6	IN1LP_MIXINL_VOL [2:0]	000 (Mute)	IN1LP Pin (PGA Bypass) to MIXINL Gain and Mute 000 = Mute 001 = -12dB 010 = -9dB 011 = -6dB 100 = -3dB 101 = 0dB 110 = +3dB 111 = +6dB (see note below). When IN1LP_MIXINL_BOOST is set, then the maximum gain setting is increased to +15dB, ie. 111 = +15dB. Note that VMID_BUF_ENA must be set when using the IN1LP (PGA Bypass) input to MIXINL.

REGISTER ADDRESS	BIT	LABEL	DEFAULT	DESCRIPTION
	2:0	IN2LRP_MIXINL_VOL [2:0]	000 (Mute)	RXVOICE Differential Input (VRXP-VRXN) to MIXINL Gain and Mute 000 = Mute 001 = -12dB 010 = -9dB 011 = -6dB 100 = -3dB 101 = 0dB 110 = +3dB 111 = +6dB

Table 7 Left Input Mixer (MIXINL) Volume Control

REGISTER ADDRESS	BIT	LABEL	DEFAULT	DESCRIPTION
R21 (0015h) Input Mixer (1)	8	IN1RP_MIXINR_BOOST	0	IN1RP Pin (PGA Bypass) to MIXINR Gain Boost. This bit selects the maximum gain setting of the IN1RP_MIXINR_VOL register. 0 = Maximum gain is +6dB 1 = Maximum gain is +15dB
R42 (002A) Input Mixer (4)	8	IN2R_TO_MIXINR	0	IN2R PGA Output to MIXINR Mute 0 = Mute 1 = Un-Mute
	7	IN2R_MIXINR_VOL	0	IN2R PGA Output to MIXINR Gain 0 = 0dB 1 = +30dB
	5	IN1R_TO_MIXINR	0	IN1R PGA Output to MIXINR Mute 0 = Mute 1 = Un-Mute
	4	IN1R_MIXINR_VOL	0	IN1R PGA Output to MIXINR Gain 0 = 0dB 1 = +30dB
	2:0	MIXOUTR_MIXINR_VOL [2:0]	000 (Mute)	Record Path MIXOUTR to MIXINR Gain and Mute 000 = Mute 001 = -12dB 010 = -9dB 011 = -6dB 100 = -3dB 101 = 0dB 110 = +3dB 111 = +6dB

REGISTER ADDRESS	BIT	LABEL	DEFAULT	DESCRIPTION
R44 (002Ch) Input Mixer (6)	8:6	IN1RP_MIXINR_VOL [2:0]	000 (Mute)	IN1RP Pin (PGA Bypass) to MIXINR Gain and Mute 000 = Mute 001 = -12dB 010 = -9dB 011 = -6dB 100 = -3dB 101 = 0dB 110 = +3dB 111 = +6dB (see note below). When IN1RP_MIXINR_BOOST is set, then the maximum gain setting is increased to +15dB, ie. 111 = +15dB. Note that VMID_BUF_ENA must be set when using the IN1RP (PGA Bypass) input to MIXINR.
	2:0	IN2LRP_MIXINR_VOL [2:0]	000 (Mute)	RXVOICE Differential Input (VRXP-VRXN) to MIXINR Gain and Mute 000 = Mute 001 = -12dB 010 = -9dB 011 = -6dB 100 = -3dB 101 = 0dB 110 = +3dB 111 = +6dB

Table 8 Right Input Mixer (MIXINR) Volume Control

DIGITAL MICROPHONE INTERFACE

The WM8958 supports a four-channel digital microphone interface. Two channels of audio data are multiplexed on the DMICDAT1 pin and a further two channels are multiplexed on the DMICDAT2 pin. All four channels are clocked using the DMICCLK output pin.

The DMICDAT1 function is shared with the IN2LN pin; the analogue signal paths from IN2LN cannot be used when this pin is used for DMICDAT1 digital microphone input.

The DMICDAT2 function is shared with the IN2RN pin; the analogue signal paths from IN2RN cannot be used when this pin is used for DMICDAT2 digital microphone input.

The digital microphone interface is referenced to the MICBIAS1 voltage domain; the MICBIAS1 output must be enabled (MICB1_ENA = 1) when using the digital microphone interface.

The MICBIAS1 generator is suitable for use as a low noise supply for the digital microphones. Note that, if the capacitive load on the MICBIAS1 generator exceeds the specified limit (eg. due to a decoupling capacitor or long PCB trace), then the MICBIAS1 generator must be configured in Bypass mode. See “Analogue Input Signal Path” for details of the MICBIAS1 generator.

When digital microphone input is enabled, the WM8958 outputs a clock signal on the DMICCLK pin.

A pair of digital microphones is connected as illustrated in Figure 16. The microphones must be configured to ensure that the Left mic transmits a data bit when DMICCLK is high, and the Right mic transmits a data bit when DMICCLK is low. The WM8958 samples the digital microphone data at the end of each DMICCLK phase. Each microphone must tri-state its data output when the other microphone is transmitting.

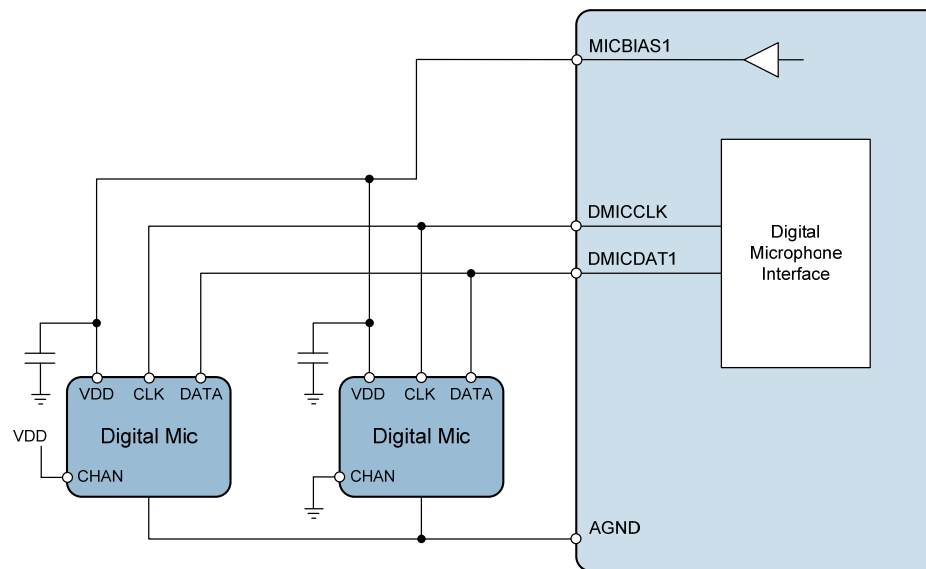

Figure 16 Digital Microphone Input

The DMICDAT1 digital microphone channels are enabled using DMIC1L_ENA and DMIC1R_ENA. When these signal paths are enabled, the respective ADC path is disconnected and the digital microphone data is routed to the digital mixing input bus, as illustrated in “Digital Mixing”.

The DMICDAT2 digital microphone channels are enabled using DMIC2L_ENA and DMIC2R_ENA. When these signal paths are enabled, the digital microphone data is routed to the digital mixing input bus, as illustrated in “Digital Mixing”.

Two microphone channels are interleaved on DMICDAT1; another two channels are interleaved on DMICDAT2. The timing is illustrated in Figure 17. Each microphone must tri-state its data output when the other microphone is transmitting.

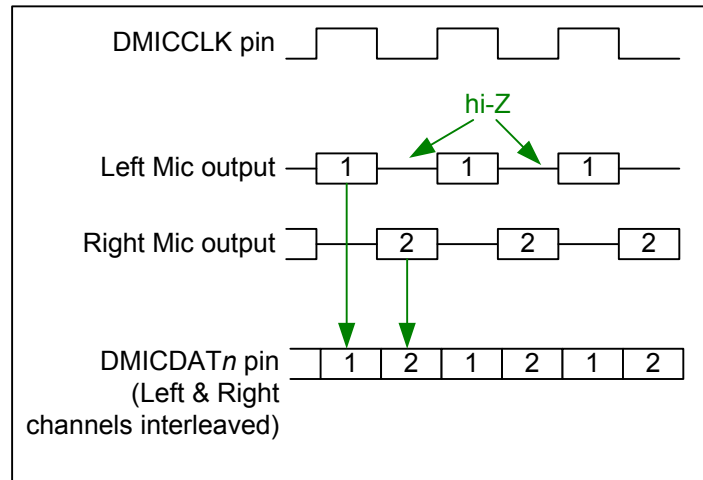

Figure 17 Digital Microphone Interface Timing

The four digital microphone channels can be routed to one of the four timeslots on AIF1. The DMICDAT1 microphones, when enabled, are routed to the Left/Right channels of AIF1 Timeslot 0. The DMICDAT2 microphones, when enabled, are routed to the Left/Right channels of AIF1 Timeslot 1.

Digital volume control of the digital microphone channels in the AIF1 signal paths is provided using the registers described in the “Digital Volume and Filter Control” section.

The digital microphone channels can be routed, in a limited number of configurations, to the digital mixing output bus, via the digital sidetone signal paths. See “Digital Mixing” for further details.

Digital volume control of the digital microphone channels in the digital sidetone signal paths is provided using the registers described in the “Digital Mixing” section.

The digital microphone interface control fields are described in Table 9.

REGISTER ADDRESS	BIT	LABEL	DEFAULT	DESCRIPTION
R4 (0004h) Power Management (4)	5	DMIC2L_ENA	0	Digital microphone DMICDAT2 Left channel enable 0 = Disabled 1 = Enabled
	4	DMIC2R_ENA	0	Digital microphone DMICDAT2 Right channel enable 0 = Disabled 1 = Enabled
	3	DMIC1L_ENA	0	Digital microphone DMICDAT1 Left channel enable 0 = Disabled 1 = Enabled
	2	DMIC1R_ENA	0	Digital microphone DMICDAT1 Right channel enable 0 = Disabled 1 = Enabled

Table 9 Digital Microphone Interface Control

Clocking for the Digital Microphone interface is derived from SYSCLK. The DMICCLK frequency is configured automatically, according to the AIFn_SR, AIFnCLK_RATE and ADC_OSR128 registers. (See "Clocking and Sample Rates" for further details of the system clocks and control registers.)

The DMICCLK is enabled whenever a digital microphone input path is enabled on the DMICDAT1 or DMICDAT2 pin(s). Note that the SYSDSPCLK_ENA register must also be set.

When AIF1CLK is selected as the SYSCLK source (SYSCLK_SRC = 0), then the DMICCLK frequency is controlled by the AIF1_SR and AIF1CLK_RATE registers.

When AIF2CLK is selected as the SYSCLK source (SYSCLK_SRC = 1), then the DMICCLK frequency is controlled by the AIF2_SR and AIF2CLK_RATE registers.

The DMICCLK frequency is as described in Table 10 (for ADC_OSR128=1) and Table 11 (for ADC_OSR128=0). The ADC_OSR128 bit is set by default, giving best audio performance. Note that the only valid DMICCLK configurations are the ones listed in Table 10 and Table 11.

The applicable clocks (SYSCLK, and AIF1CLK or AIF2CLK) must be present and enabled when using the digital microphone interface.

SAMPLE RATE (kHz)	SYSCLK RATE (AIFnCLK / fs ratio)							
	128	192	256	384	512	768	1024	1536
8					2.048		2.048	2.048
11.025					2.8224		2.8224	
12					3.072		3.072	
16			2.048		2.048	2.048		
22.05			2.8224		2.8224			
24			3.072		3.072			
32			2.048					
44.1			2.8224					
48			3.072					
88.2								
96								

Note that, when ADC_OSR128=1, digital microphone operation is only supported for the above DMICCLK configurations.

Table 10 DMICCLK Frequency (MHz) - ADC_OSR128 = 1 (Default)

SAMPLE RATE (kHz)	SYSCLK RATE (AIFnCLK / fs ratio)							
	128	192	256	384	512	768	1024	1536
8			1.024		1.024	1.024	1.024	1.024
11.025			1.4112		1.4112	1.4112	1.4112	
12			1.536		1.536	1.536	1.536	
16			1.024	1.024	1.024	1.024		
22.05			1.4112	1.4112	1.4112			
24			1.536	1.536	1.536			
32			2.048	2.048				
44.1			2.8224					
48			3.072					
88.2								
96								

Note that, when ADC_OSR128=0, digital microphone operation is only supported for the above DMICCLK configurations.

Table 11 DMICCLK Frequency (MHz) - ADC_OSR128 = 0

DIGITAL PULL-UP AND PULL-DOWN

The WM8958 provides integrated pull-up and pull-down resistors on the DMICDAT1 and DMICDAT2 pins. This provides a flexible capability for interfacing with other devices. Each of the pull-up and pull-down resistors can be configured independently using the register bits described in Table 12.

Note that, if the DMICDAT1 or DMICDAT2 digital microphone channels are disabled, or if DMICDATn_PU and DMICDATn_PD are both set, then the pull-up and pull-down will be disabled on the respective pin.

REGISTER ADDRESS	BIT	LABEL	DEFAULT	DESCRIPTION
R1824 (0720h) Pull Control (1)	11	DMICDAT2_PU	0	DMICDAT2 Pull-Up enable 0 = Disabled 1 = Enabled
	10	DMICDAT2_PD	0	DMICDAT2 Pull-Down enable 0 = Disabled 1 = Enabled
	9	DMICDAT1_PU	0	DMICDAT1 Pull-Up enable 0 = Disabled 1 = Enabled
	8	DMICDAT1_PD	0	DMICDAT1 Pull-Down enable 0 = Disabled 1 = Enabled

Table 12 Digital Pull-Up and Pull-Down Control

ANALOGUE TO DIGITAL CONVERTER (ADC)

The WM8958 uses stereo 24-bit sigma-delta ADCs. The use of multi-bit feedback and high oversampling rates reduces the effects of jitter and high frequency noise. The oversample rate can be adjusted, if required, to reduce power consumption - see "Clocking and Sample Rates" for details. The ADC full scale input level is proportional to AVDD1 - see "Electrical Characteristics". Any input signal greater than full scale may overload the ADC and cause distortion.

The ADCs are enabled by the ADCL_ENA and ADCR_ENA register bits.

REGISTER ADDRESS	BIT	LABEL	DEFAULT	DESCRIPTION
R4 (0004h) Power Management (4)	1	ADCL_ENA	0	Left ADC Enable 0 = Disabled 1 = Enabled
	0	ADCR_ENA	0	Right ADC Enable 0 = Disabled 1 = Enabled

Table 13 ADC Enable Control

The outputs of the ADCs can be routed to the Left/Right channels of AIF1 (Timeslot 0).

Digital volume control of the ADC outputs in the AIF1 signal paths is provided using the registers described in the "Digital Volume and Filter Control" section.

The outputs of the ADCs can be routed, in a limited number of configurations, to the digital mixing output bus, via the digital sidetone signal paths. See "Digital Mixing" for further details.

Digital volume control of the ADC outputs in the digital sidetone signal paths is provided using the registers described in the "Digital Mixing" section.

ADC CLOCKING CONTROL

Clocking for the ADCs is derived from SYSCLK. The required clock is enabled when the SYSDSPCLK_ENA register is set.

The ADC clock rate is configured automatically, according to the AIFn_SR, AIFnCLK_RATE and ADC_OSR128 registers. (See “Clocking and Sample Rates” for further details of the system clocks and control registers.)

When AIF1CLK is selected as the SYSCLK source (SYSCLK_SRC = 0), then the ADC clocking is controlled by the AIF1_SR and AIF1CLK_RATE registers.

When AIF2CLK is selected as the SYSCLK source (SYSCLK_SRC = 1), then the ADC clocking is controlled by the AIF2_SR and AIF2CLK_RATE registers.

The supported ADC clocking configurations are described in Table 14 (for ADC_OSR128=1) and Table 15 (for ADC_OSR128=0). The ADC_OSR128 bit is set by default, giving best audio performance.

SAMPLE RATE (kHz)	SYSCLK RATE (AIFnCLK / fs ratio)							
	128	192	256	384	512	768	1024	1536
8					✓		✓	✓
11.025					✓		✓	
12					✓		✓	
16			✓	✓	✓	✓		
22.05			✓	✓	✓			
24			✓	✓	✓			
32			✓	✓				
44.1			✓					
48			✓					
88.2								
96								

When ADC_OSR128=1, ADC operation is only supported for the configurations indicated above

Table 14 ADC Clocking - ADC_OSR128 = 1 (Default)

SAMPLE RATE (kHz)	SYSCLK RATE (AIFnCLK / fs ratio)							
	128	192	256	384	512	768	1024	1536
8			✓	✓	✓	✓	✓	✓
11.025			✓	✓	✓	✓	✓	
12			✓	✓	✓	✓	✓	
16			✓	✓	✓	✓		
22.05			✓	✓	✓			
24			✓	✓	✓			
32			✓	✓				
44.1			✓					
48			✓					
88.2								
96								

When ADC_OSR128=0, ADC operation is only supported for the configurations indicated above

Table 15 ADC Clocking - ADC_OSR128 = 0

The clocking requirements in Table 14 and Table 15 are only applicable to the AIFnCLK that is selected as the SYSCLK source. Note that both clocks (AIF1CLK and AIF2CLK) must satisfy the requirements noted in the “Clocking and Sample Rates” section.

The applicable clocks (SYSCLK, and AIF1CLK or AIF2CLK) must be present and enabled when using the Analogue to Digital Converters (ADCs).

DIGITAL CORE ARCHITECTURE

The WM8958 Digital Core provides an extensive set of mixing and signal processing features. The Digital Core Architecture is illustrated in Figure 18, which also identifies the datasheet sections applicable to each portion of the Digital Core.

Audio Interface 1 (AIF1) supports audio input and output on two stereo timeslots simultaneously, making a total of four inputs and four outputs. The mixing of the four AIF1 output paths is described in "Audio Interface 1 (AIF1) Output Mixing".

A digital mixing path from the ADCs or Digital Microphones to the DAC output paths provides a high quality sidetone for voice calls or other applications. The sidetone configuration is described in "Digital Sidetone Mixing"; the associated filter and volume control is described in "Digital Sidetone Volume and Filter Control".

Each of the four hi-fi DACs has a dedicated mixer for controlling the signal paths to that DAC. The configuration of these signal paths is described in "DAC Output Digital Mixing".

Each DAC is provided with digital volume control, soft mute / un-mute and a low pass filter. The associated controls are defined in the "Digital to Analogue Converter (DAC)" section.

Digital processing can be applied to the four input channels of AIF1 and the two input channels of AIF2. The available features include multiband compression (MBC), 5-band equalization (EQ), 3D stereo expansion and dynamic range control (DRC).

The MBC provides a function to maximise the loudness of the audio signal, using independent compression and boost of different frequency bands without overdriving the loudspeakers. The RMS Limiter within the MBC function enables the maximum signal level to be matched to the application requirements and/or power rating of the loudspeaker. The MBC controls are described in "Multiband Compressor". The EQ provides the capability to tailor the audio path according to the frequency characteristics of an earpiece or loudspeaker, and/or according to user preferences. The EQ controls are described in "ReTune™ Mobile Parametric Equalizer (EQ)".

The DRC provides adaptive signal level control to improve the handling of unpredictable signal levels and to improve intelligibility in the presence of transients and impulsive noises. The DRC controls are described in "Dynamic Range Control (DRC)". 3D stereo expansion provides a stereo enhancement effect; the depth of the effect is programmable, as described in "3D Stereo Expansion".

The input channels of AIF1 and AIF2 are also equipped with digital volume control and soft mute / un-mute control; see "Digital Volume and Filter Control" for details of these features.

The output channels of AIF1 and AIF2 can be configured using the digital volume control and a programmable high-pass filter (HPF). The Dynamic Range Control (DRC) circuit can also be applied here, with the restriction that a DRC cannot be enabled in the input and output path of one AIF channel at the same time. The AIF output volume and filter controls are described in "Digital Volume and Filter Control".

The WM8958 provides an ultrasonic mode on the output paths of AIF1, allowing high frequency signals (such as ultrasonic microphone signals) to be output. See "Ultrasonic (4FS) AIF Output Mode" for further details.

The WM8958 provides two full audio interfaces, AIF1 and AIF2. Each interface supports a number of protocols, including I²S, DSP, MSB-first left/right justified, and can operate in master or slave modes. PCM operation is supported in the DSP mode. A-law and μ -law companding are also supported. Time division multiplexing (TDM) is available to allow multiple devices to stream data simultaneously on the same bus, saving space and power.

Four-channel input and output is supported using TDM on AIF1. Two-channel input and output is supported on AIF2. A third interface, AIF3, is partially supported, using multiplexers to re-configure alternate connections to AIF1 or AIF2.

Signal mixing between audio interfaces is possible. The WM8958 performs stereo full-duplex sample rate conversion between the audio interfaces as required. (Note that sample rate conversion is not supported on some signal paths, as noted in Figure 18.)

The audio interfaces AIF1, AIF2 and AIF3 are referenced to DBVDD1, DBVDD2 and DBVDD3 respectively; this provides additional capability to interface between different sub-systems within an application.

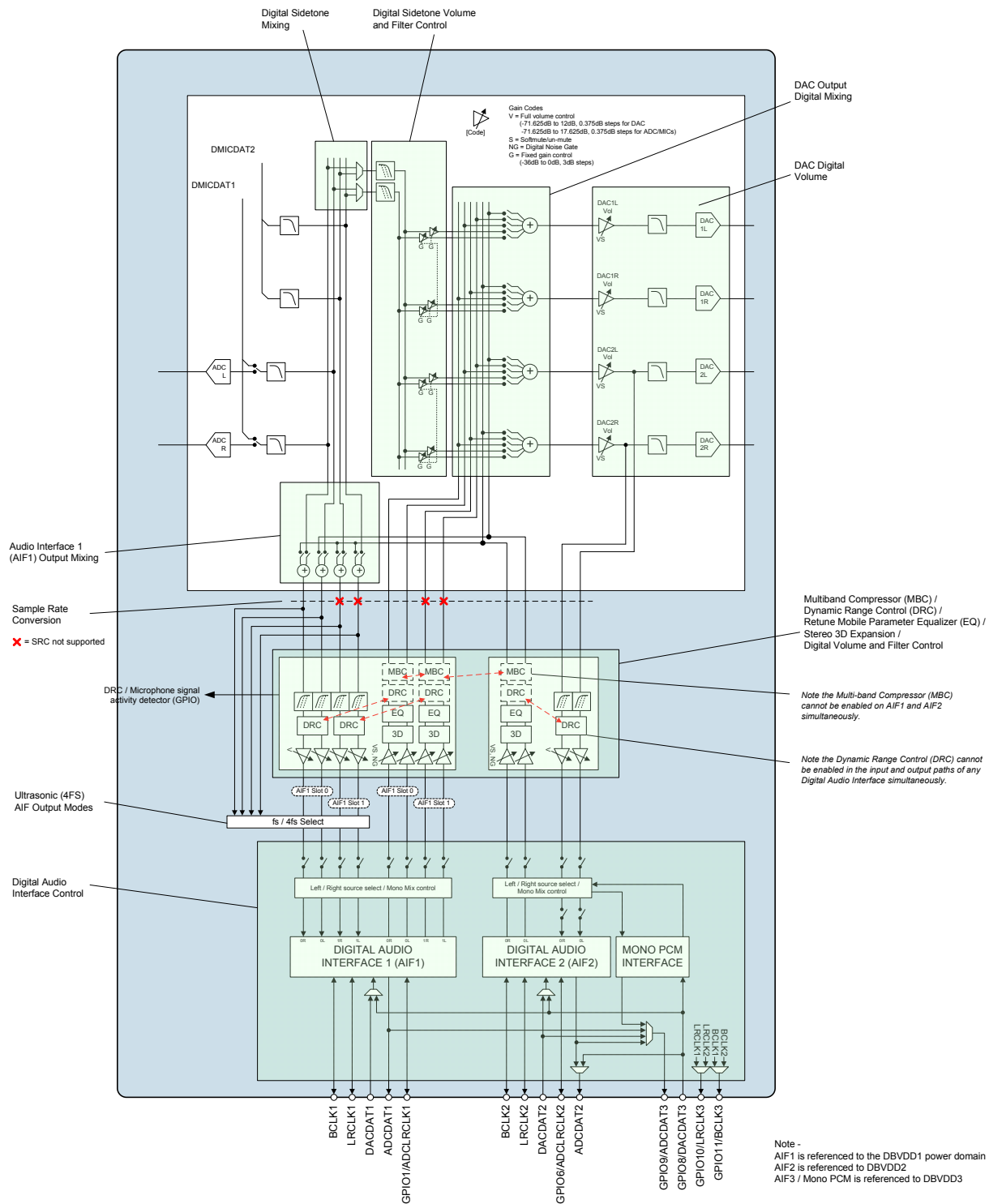

Figure 18 Digital Core Architecture

DIGITAL MIXING

This section describes the digital mixing functions of the WM8958.

Digital audio mixing is provided on four AIF1 output paths, two digital sidetone paths, and four Digital to Analogue converters (DACs).

Note that the two AIF2 output paths are connected to the DAC2L and DAC2R signal paths.

The digital mixing functions and associated control registers are illustrated in Figure 19.

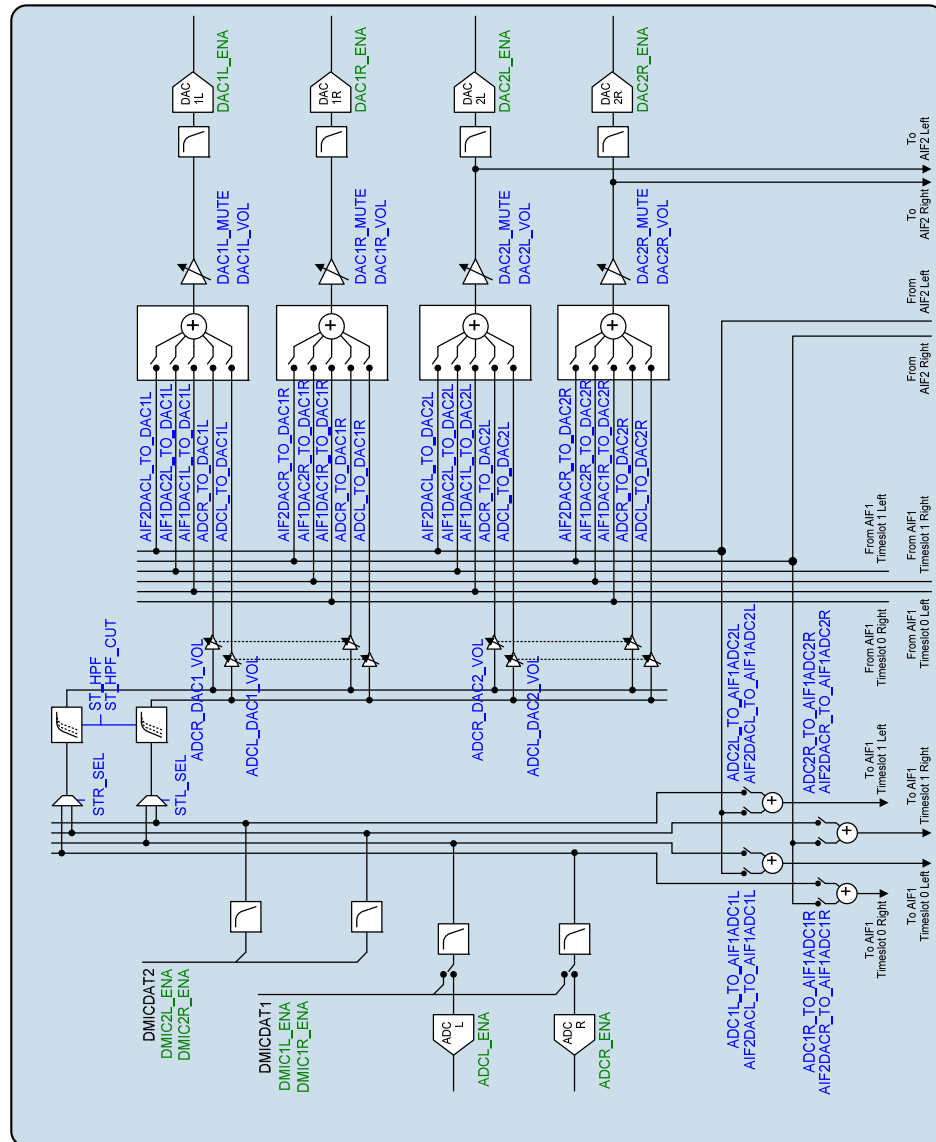

Figure 19 Digital Mixing Block Diagram

AUDIO INTERFACE 1 (AIF1) OUTPUT MIXING

There are four AIF1 digital mixers, one for each AIF1 audio channel (ie. Left/Right channels on Timeslots 0/1). The inputs to each AIF1 mixer comprise signals from the ADC / Digital Microphone inputs and from AIF2.

Note that the Left/Right channels of AIF1 can be inverted or interchanged if required; see "Digital Audio Interface Control".

The AIF1 Left Timeslot 0 output channel is derived from the ADCL / DMIC1 (Left) and AIF2 (Left) inputs. The ADCL / DMIC1 (Left) path is enabled by ADC1L_TO_AIF1ADC1L, whilst the AIF2 (Left) path is enabled by AIF2DACL_TO_AIF1ADC1L.

The AIF1 Right Timeslot 0 output channel is derived from the ADCR / DMIC1 (Right) and AIF2 (Right) inputs. The ADCR / DMIC1 (Right) path is enabled by ADC1R_TO_AIF1ADC1R, whilst the AIF2 (Right) path is enabled by AIF2DACR_TO_AIF1ADC1R.

The AIF1 Left Timeslot 1 output channel is derived from the DMIC2 (Left) and AIF2 (Left) inputs. The DMIC2 (Left) path is enabled by ADC2L_TO_AIF1ADC2L, whilst the AIF2 (Left) path is enabled by AIF2DACL_TO_AIF1ADC2L.

The AIF1 Right Timeslot 1 output channel is derived from the DMIC2 (Right) and AIF2 (Right) inputs. The DMIC2 (Right) path is enabled by ADC2R_TO_AIF1ADC2R, whilst the AIF2 (Right) path is enabled by AIF2DACR_TO_AIF1ADC2R.

The AIF1 output mixer controls are defined in Table 16.

REGISTER ADDRESS	BIT	LABEL	DEFAULT	DESCRIPTION
R1542 (0606h) AIF1 ADC1 Left Mixer Routing	1	ADC1L_TO_AIF1ADC1L	0	Enable ADCL / DMIC1 (Left) to AIF1 (Timeslot 0, Left) output 0 = Disabled 1 = Enabled
	0	AIF2DACL_TO_AIF1ADC1L	0	Enable AIF2 (Left) to AIF1 (Timeslot 0, Left) output 0 = Disabled 1 = Enabled
R1543 (0607h) AIF1 ADC1 Right Mixer Routing	1	ADC1R_TO_AIF1ADC1R	0	Enable ADCR / DMIC1 (Right) to AIF1 (Timeslot 0, Right) output 0 = Disabled 1 = Enabled
	0	AIF2DACR_TO_AIF1ADC1R	0	Enable AIF2 (Right) to AIF1 (Timeslot 0, Right) output 0 = Disabled 1 = Enabled
R1544 (0608h) AIF1 ADC2 Left Mixer Routing	1	ADC2L_TO_AIF1ADC2L	0	Enable DMIC2 (Left) to AIF1 (Timeslot 1, Left) output 0 = Disabled 1 = Enabled
	0	AIF2DACL_TO_AIF1ADC2L	0	Enable AIF2 (Left) to AIF1 (Timeslot 1, Left) output 0 = Disabled 1 = Enabled
R1545 (0609h) AIF1 ADC2 Right Mixer Routing	1	ADC2R_TO_AIF1ADC2R	0	Enable DMIC2 (Right) to AIF1 (Timeslot 1, Right) output 0 = Disabled 1 = Enabled
	0	AIF2DACR_TO_AIF1ADC2R	0	Enable AIF2 (Right) to AIF1 (Timeslot 1, Right) output 0 = Disabled 1 = Enabled

Table 16 AIF1 Output Mixing

DIGITAL SIDETONE MIXING

There are two digital sidetone signal paths, STL and STR. The sidetone sources are selectable for each path. The sidetone mixer outputs are inputs to the DAC signal mixers.

The following sources can be selected for sidetone path STL.

- ADCL or DMICDAT1 (Left) channel
- DMICDAT2 (Left) channel

The following sources can be selected for sidetone path STR.

- ADCR or DMICDAT1 (Right) channel
- DMICDAT2 (Right) channel

The sidetone signal sources are selected using STR_SEL and STL_SEL as described in Table 17. Note that, when STR_SEL = 0 or STL_SEL = 0, and the respective ADC is enabled (for analogue inputs), then the ADC data will be selected for applicable sidetone path.

REGISTER ADDRESS	BIT	LABEL	DEFAULT	DESCRIPTION
R1569 (0621h) Sidetone	1	STR_SEL	0	Select source for sidetone STR path 0 = ADCR / DMICDAT1 (Right) 1 = DMICDAT2 (Right)
	0	STL_SEL	0	Select source for sidetone STL path 0 = ADCL / DMICDAT1 (Left) 1 = DMICDAT2 (Left)

Table 17 Digital Sidetone Mixing

DIGITAL SIDETONE VOLUME AND FILTER CONTROL

A digital volume control is provided for the digital sidetone paths. The associated register controls are described in Table 18.

A digital high-pass filter can be enabled in the sidetone paths to remove DC offsets. This filter is enabled using the ST_HPF register bit; the cut-off frequency is configured using ST_HPF_CUT. When the filter is enabled, it is enabled in both digital sidetone paths.

Note that the sidetone filter cut-off frequency scales according to the sample rate of AIF1 or AIF2. When AIF1CLK is selected as the SYSCLK source (SYSCLK_SRC = 0), then the ST_HPF cut-off frequency is scaled according to the AIF1_SR register. When AIF2CLK is selected as the SYSCLK source (SYSCLK_SRC = 1), then the ST_HPF cut-off frequency is scaled according to the AIF2_SR register. See "Clocking and Sample Rates" for further details of the system clocks and control registers.

REGISTER ADDRESS	BIT	LABEL	DEFAULT	DESCRIPTION
R1536 (0600h) DAC1 Mixer Volumes	8:5	ADCR_DAC1_V OL [3:0]	0000	Sidetone STR to DAC1L and DAC1R Volume 0000 = -36dB 0001 = -33dB (3dB steps) 1011 = -3dB 1100 = 0dB (see Table 19 for gain range)

REGISTER ADDRESS	BIT	LABEL	DEFAULT	DESCRIPTION
	3:0	ADCL_DAC1_V OL [3:0]	0000	Sidetone STL to DAC1L and DAC1R Volume 0000 = -36dB 0001 = -33dB (3dB steps) 1011 = -3dB 1100 = 0dB (see Table 19 for gain range)
R1539 (0603h) DAC2 Mixer Volumes	8:5	ADCR_DAC2_V OL [3:0]	0000	Sidetone STR to DAC2L and DAC2R Volume 0000 = -36dB 0001 = -33dB (3dB steps) 1011 = -3dB 1100 = 0dB (see Table 19 for gain range)
	3:0	ADCL_DAC2_V OL [3:0]	0000	Sidetone STL to DAC2L and DAC2R Volume 0000 = -36dB 0001 = -33dB (3dB steps) 1011 = -3dB 1100 = 0dB (see Table 19 for gain range)
R1569 (0621h) Sidetone	9:7	ST_HPF_CUT [2:0]	000	Sidetone HPF cut-off frequency (relative to 44.1kHz sample rate) 000 = 2.7kHz 001 = 1.35kHz 010 = 675Hz 011 = 370Hz 100 = 180Hz 101 = 90Hz 110 = 45Hz 111 = Reserved Note - the cut-off frequencies scale with the Digital Mixing (SYSCLK) clocking rate. The quoted figures apply to 44.1kHz sample rate.
	6	ST_HPF	0	Digital Sidetone HPF Select 0 = Disabled 1 = Enabled

Table 18 Digital Sidetone Volume Control

ADCR_DAC1_VOL, ADCL_DAC2_VOL, ADCR_DAC1_VOL or ADCL_DAC2_VOL	SIDETONE GAIN (dB)
0000	-36
0001	-33
0010	-30
0011	-27
0100	-24
0101	-21
0110	-18
0111	-15
1000	-12
1001	-9
1010	-6
1011	-3
1100	0
1101	0
1110	0
1111	0

Table 19 Digital Sidetone Volume Range

DAC OUTPUT DIGITAL MIXING

There are four DAC digital mixers, one for each DAC. The inputs to each DAC mixer comprise signals from AIF1, AIF2 and the digital sidetone signals.

Note that the Left/Right channels of the AIF1 and AIF2 inputs can be inverted or interchanged if required; see "Digital Audio Interface Control".

REGISTER ADDRESS	BIT	LABEL	DEFAULT	DESCRIPTION
R1537 (0601h) DAC1 Left Mixer Routing	5	ADCR_TO_DAC 1L	0	Enable Sidetone STR to DAC1L 0 = Disabled 1 = Enabled
	4	ADCL_TO_DAC 1L	0	Enable Sidetone STL to DAC1L 0 = Disabled 1 = Enabled
	2	AIF2DACL_TO_ DAC1L	0	Enable AIF2 (Left) to DAC1L 0 = Disabled 1 = Enabled
	1	AIF1DAC2L_TO _DAC1L	0	Enable AIF1 (Timeslot 1, Left) to DAC1L 0 = Disabled 1 = Enabled
	0	AIF1DAC1L_TO _DAC1L	0	Enable AIF1 (Timeslot 0, Left) to DAC1L 0 = Disabled 1 = Enabled
R1538 (0602h) DAC1 Right Mixer Routing	5	ADCR_TO_DAC 1R	0	Enable Sidetone STR to DAC1R 0 = Disabled 1 = Enabled
	4	ADCL_TO_DAC 1R	0	Enable Sidetone STL to DAC1R 0 = Disabled 1 = Enabled
	2	AIF2DACR_TO_ DAC1R	0	Enable AIF2 (Right) to DAC1R 0 = Disabled 1 = Enabled

REGISTER ADDRESS	BIT	LABEL	DEFAULT	DESCRIPTION
	1	AIF1DAC2R_TO_DAC1R	0	Enable AIF1 (Timeslot 1, Right) to DAC1R 0 = Disabled 1 = Enabled
	0	AIF1DAC1R_TO_DAC1R	0	Enable AIF1 (Timeslot 0, Right) to DAC1R 0 = Disabled 1 = Enabled
R1540 (0604h) DAC2 Left Mixer Routing	5	ADCR_TO_DAC2L	0	Enable Sidetone STR to DAC2L 0 = Disabled 1 = Enabled
	4	ADCL_TO_DAC2L	0	Enable Sidetone STL to DAC2L 0 = Disabled 1 = Enabled
	2	AIF2DACL_TO_DAC2L	0	Enable AIF2 (Left) to DAC2L 0 = Disabled 1 = Enabled
	1	AIF1DAC2L_TO_DAC2L	0	Enable AIF1 (Timeslot 1, Left) to DAC2L 0 = Disabled 1 = Enabled
	0	AIF1DAC1L_TO_DAC2L	0	Enable AIF1 (Timeslot 0, Left) to DAC2L 0 = Disabled 1 = Enabled
R1541 (0605h) DAC2 Right Mixer Routing	5	ADCR_TO_DAC2R	0	Enable Sidetone STR to DAC2R 0 = Disabled 1 = Enabled
	4	ADCL_TO_DAC2R	0	Enable Sidetone STL to DAC2R 0 = Disabled 1 = Enabled
	2	AIF2DACR_TO_DAC2R	0	Enable AIF2 (Right) to DAC2R 0 = Disabled 1 = Enabled
	1	AIF1DAC2R_TO_DAC2R	0	Enable AIF1 (Timeslot 1, Right) to DAC2R 0 = Disabled 1 = Enabled
	0	AIF1DAC1R_TO_DAC2R	0	Enable AIF1 (Timeslot 0, Right) to DAC2R 0 = Disabled 1 = Enabled

Table 20 DAC Output Digital Mixing

AUDIO INTERFACE 2 (AIF2) DIGITAL MIXING

There are two output channels on AIF2. The audio source for these two channels is the same as the selected source for DAC2L and DAC2R, as described in "DAC Output Digital Mixing".

Note that the Left/Right channels of AIF2 can be inverted or interchanged if required; see "Digital Audio Interface Control".

ULTRASONIC (4FS) AIF OUTPUT MODE

The WM8958 provides an ultrasonic mode on the output paths of the AIF1 audio interface. The ultrasonic mode enables high frequency signals (such as ultrasonic microphone signals) to be output.

Ultrasonic mode is enabled on AIF1 using the AIF1ADC_4FS register bit. When the ultrasonic mode is selected, the AIF1 output sample rate is increased by a factor of 4. For example, a 48kHz sample rate will be output at 192kHz in ultrasonic mode.

Ultrasonic mode is only supported in AIF Master mode and uses the ADCLRCLK output (not the LRCLK). When ultrasonic mode is enabled, the AIF1 must be configured in Master mode, as described in "Digital Audio Interface Control". See "General Purpose Input/Output" to configure the GPIO1 pin as ADCLRCLK1. The ADCLRCLK1 rate is controlled as described in "Digital Audio Interface Control".

When ultrasonic mode is enabled, the audio band filtering and digital volume controls (see "Digital Volume and Filter Control") are bypassed on the affected output paths.

The Dynamic Range Control (DRC) function is not available on the AIF1 output signal paths in ultrasonic mode. Note, however, that the DRC is still available on the AIF input paths in this case.

The ultrasonic (4FS) signal paths are illustrated in Figure 20. The AIF1ADC_4FS register bit is defined in Table 21.

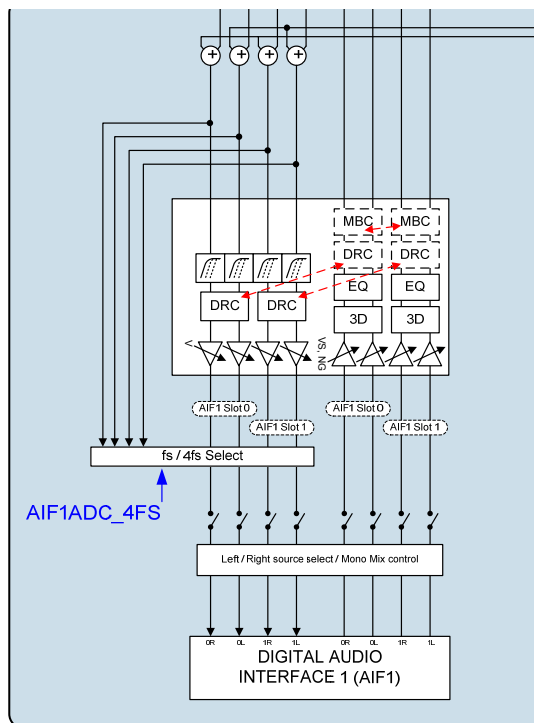

Figure 20 Ultrasonic (4FS) Signal Paths

REGISTER ADDRESS	BIT	LABEL	DEFAULT	DESCRIPTION
R1040 (0410h) AIF1 ADC1 Filters	15	AIF1ADC_4FS	0	Enable AIF1ADC ultrasonic mode (4FS) output, bypassing all AIF1 baseband output filtering 0 = Disabled 1 = Enabled

Table 21 Ultrasonic (4FS) Mode Control

MULTIBAND COMPRESSOR (MBC)

The Multiband Compressor (MBC) is a DSP function which can be enabled in the digital playback path of the WM8958 audio interfaces. The normal function of the MBC is to maximise the loudness of the audio signal.

The MBC uses selective processing of the received digital audio signal to control the loudness; independent gain control algorithms are applied to different audio frequency bands. The effect of this is to increase the perceived loudness of the audio path, producing an enhanced audio signal without overdriving the output transducers (eg. loudspeakers).

The MBC provides two internal signal paths, allowing low frequencies and high frequencies to be processed separately. Each signal path incorporates a programmable compressor which can be used to dynamically control the level of each frequency band.

The most significant advantage of multiband compression is that a signal peak in one frequency band will not cause gain reduction in the other frequency band. Similarly, gain can be applied to one frequency band without boosting (and potentially distorting) the other. This provides a powerful capability to maximise the loudness of the signal path.

The two signal paths are re-combined at the output of the MBC. If necessary, any difference in tonal balance between the frequency bands can be restored by changing the levels of the two signal paths relative to each other.

The MBC incorporates a high-pass and a low-pass filter, which set the lower and upper frequency limits of the MBC signal path. The crossover frequency that divides the two frequency bands can be adjusted according to the system requirements. The attack and decay times of the compressors are separately programmable on each frequency band.

An RMS Limiter is included within the MBC function. This is a signal limiter that responds to the RMS output level of the digital playback path, allowing the maximum signal level to be matched to the application requirements and/or the power rating of the loudspeaker.

The WM8958 provides one stereo Multiband Compressor (MBC). The MBC can be enabled on the input path of AIF1 timeslot 0, AIF1 timeslot 1 or on the input path of AIF2. Note that the MBC cannot be enabled on more than one of these paths simultaneously.

A Dynamic Range Control (DRC) function is also available on the digital playback paths. Note that the DRC and MBC functions should not be enabled simultaneously on the same playback path. The DRC is enabled using the registers described in Table 27.

The MBC signal paths and control parameters are illustrated in Figure 21.

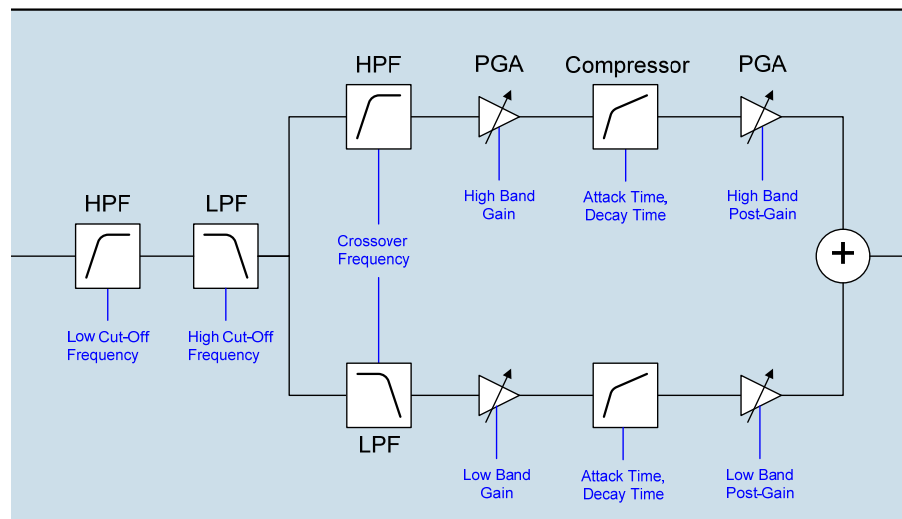

Figure 21 Multiband Compressor

The MBC filter cut-off frequencies are shown in Table 22.

PARAMETER	MIN	DEFAULT	MAX
Low Cut-Off Frequency	20Hz	350Hz	1kHz
Crossover Frequency	500Hz	2.5kHz	7.9kHz
High Cut-Off Frequency	11kHz	12kHz	16kHz

Table 22 Multiband Compressor Cut-Off Frequencies

RMS LIMITER

An RMS Limiter is included within the MBC function. This is a signal limiter that responds to the RMS output level of the digital playback path, allowing the maximum signal level to be matched to the application requirements and/or the power rating of the loudspeaker.

The Wolfson WISCE™ software must be used to derive the register settings for the RMS Limiter. The WISCE™ software allows users to select the desired RMS voltage level of the analogue output.

Note that the selected RMS voltage level applies to each output pin. For differential (BTL) outputs, note that a limit of 1.0Vrms on each pin equates to 2.0Vrms across the load.

The MBC operates within the digital core of the WM8958, and the playback signal may be subject to boost or attenuation in the digital and/or analogue stages of the output signal path. Therefore, the RMS Limiter configuration must take account of the applicable gain settings of the output signal path.

The WISCE™ software allows the user to input the amount of gain (dB) applicable to the relevant output signal path. (This is the total signal gain of the applicable DACs, output/boost mixers and PGA volume controls.) Note that the register settings for the RMS Limiter will only be valid for the specified gain level.

MBC CLOCKING CONTROL

Clocking for the MBC is derived from DSP2CLK. This clock is derived from the output of the AIF1CLK_SRC or AIF2CLK_SRC multiplexers, according to the SYSCLK_SRC register. This is illustrated in Figure 22, and described further in the “Clocking and Sample Rates” section.

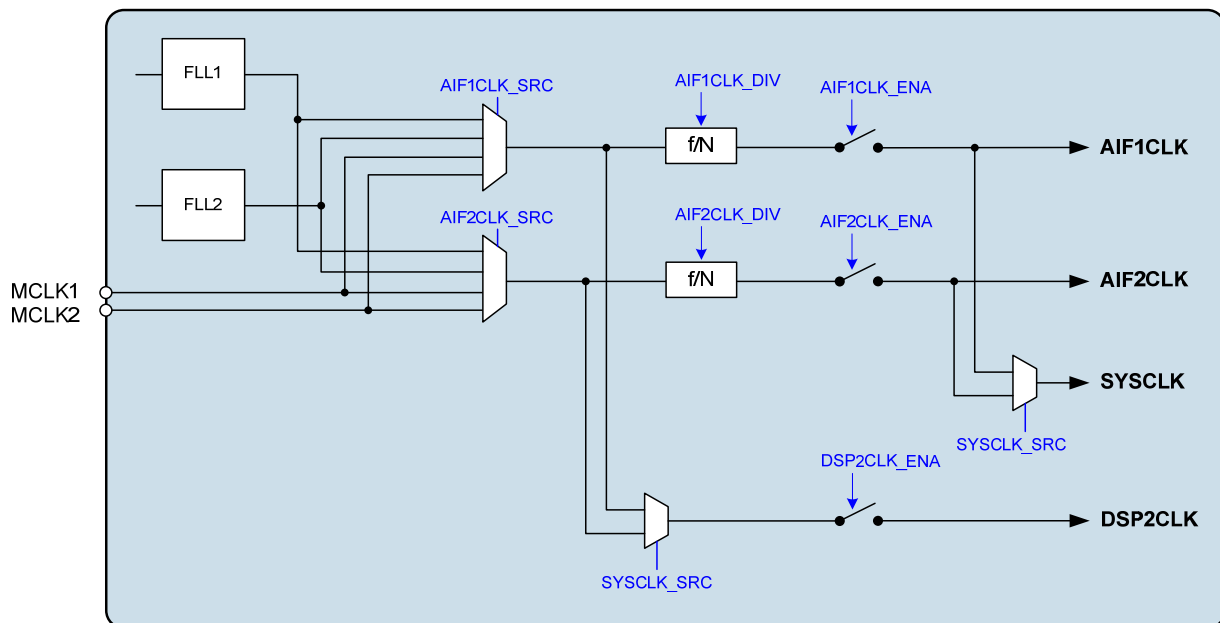

Figure 22 Audio Interface Clock Control

The MBC can be enabled on the AIF1 or AIF2 input paths, regardless of the SYSCLK_SRC setting, provided that the minimum clocking requirement for the MBC is satisfied.

To support the MBC function, it is required that $DSP2CLK \geq 256 \times fs$ (where fs is the sample rate of the AIF on which the MBC is enabled). When the MBC is enabled on either of the AIF1 input paths, it is required that $DSP2CLK \geq 256 \times AIF1_SR$; when the MBC is enabled on the AIF2 input path, it is required that $DSP2CLK \geq 256 \times AIF2_SR$.

The MBC is supported in 44.1kHz and 48kHz AIF sample rate modes only; note that these modes require clocking rates of $AIFnCLK = 256 \times fs$. (See "Digital to Analogue Converter (DAC)" for details of the valid clocking rates.)

The DSP2CLK clock for the MBC is enabled when the DSP2CLK_ENA register is set. The DSP2CLK clock is required for running the MBC function, and also for accessing any of the MBC configuration registers. Note that the applicable source clock must also be present when using DSP2CLK.

See "Clocking and Sample Rates" for details of the WM8958 clocking control registers.

MBC CONTROL SEQUENCES

Specific control sequences must be followed when enabling or configuring the MBC function; these sequences are described in Table 23 to Table 25. The associated MBC control registers are described in Table 26.

Note that the WM8958 is provided with a working set of default MBC configuration parameters, allowing the MBC feature to be enabled easily in a default operating mode. For user-specific configuration of the MBC, the Wolfson WISCE™ software must be used to derive the configuration parameters (refer to WISCE™ for further information).

The control sequence for enabling the MBC is described in Table 23. It is recommended that the applicable DAC playback path is muted during this sequence, as described below.

For user-specific configuration of the MBC, the configuration parameters should be written in Step 7 of the control sequence. For default MBC operation, Step 7 can be omitted.

STEP	DESCRIPTION	NOTES
1	Mute the applicable DAC output(s)	The DAC Volume and Mute controls are described in Table 57.
2	Set DSP2CLK_ENA = 1	
3	Set DSP2_ENA = 1	
4	Set Register R2568 (0A08h) = 007Bh	
5	Set Register R2569 (0A09h) = 0007h	
6	Set Register R2570 (0A0Ah) = 0073h	
7	Set the configuration parameters	Refer to WISCE™ for register settings. Omit this step for default MBC configuration.
8	Write DSP2_RUNR = 1	
9	Set MBC_SEL as required	For AIF1DAC1 path, set MBC_SEL = 00. For AIF1DAC2 path, set MBC_SEL = 01. For AIF2DAC path, set MBC_SEL = 10.
	Set MBC_ENA = 1	
10	Un-mute the applicable DAC output(s)	

Table 23 MBC Enable Sequence

The control sequence for disabling the MBC is described in Table 24. It is recommended that the applicable DAC playback path is muted during this sequence, as described below.

STEP	DESCRIPTION	NOTES
1	Mute the applicable DAC output(s)	The DAC Volume and Mute controls are described in Table 57.
2	Set MBC_ENA = 0	
3	Un-mute the applicable DAC output(s)	
4	Set DSP2_ENA = 0	
5	Set DSP2CLK_ENA = 0	

Table 24 MBC Disable Sequence

The control sequence for updating the MBC configuration parameters is described in Table 25. It is recommended that the applicable DAC playback paths are muted during this sequence, as described below.

The same sequence is required when reading the MBC configuration parameters; note that readback of these registers is not possible when the MBC function is active.

STEP	DESCRIPTION	NOTES
1	Mute the applicable DAC output(s)	The DAC Volume and Mute controls are described in Table 57. (If changing the MBC from one signal path to another, then both DAC paths should be muted.)
2	Set MBC_ENA = 0	
3	Write DSP2_STOP = 1	
4	Readback the MBC configuration parameters	Refer to WISCE™ for register settings.
5	Set Register R2568 (0A08h) = 007Bh Set Register R2569 (0A09h) = 0007h Set Register R2570 (0A0Ah) = 0073h Set the configuration parameters	Refer to WISCE™ for register settings. Note that these actions are only required for user-specific MBC configuration.
6	Write DSP2_RUNR = 1	
7	Set MBC_SEL	For AIF1DAC1 path, set MBC_SEL = 00. For AIF1DAC2 path, set MBC_SEL = 01. For AIF2DAC path, set MBC_SEL = 10.
	Set MBC_ENA = 1	
8	Un-mute the applicable DAC output(s)	

Table 25 MBC Update / Readback Sequence

The MBC control registers are described in Table 26.

REGISTER ADDRESS	BIT	LABEL	DEFAULT	DESCRIPTION
R2304 (0900h) DSP2_Program	0	DSP2_ENA	0	DSP2 Audio Processor Enable. 0 = Disabled 1 = Enabled This bit must be set before the MBC is enabled. It must remain set whenever the MBC is enabled.
R2305 (0901h) DSP2_Config	5:4	MBC_SEL [1:0]	00	MBC Signal Path select 00 = AIF1DAC1 input path (AIF1, Timeslot 0) 01 = AIF1DAC2 input path (AIF1, Timeslot 1) 10 = AIF2DAC input path 11 = Reserved
	0	MBC_ENA	0	MBC Enable 0 = Disabled 1 = Enabled
R2573 (0A0Dh) DSP2_ExecControl	2	DSP2_STOP	0	Stop the DSP2 audio processor Writing a 1 to this bit will cause the DSP2 processor to stop processing audio data
	1	DSP2_RUNR	0	Start the DSP2 audio processor Writing a 1 to this bit will cause the DSP2 processor to start processing audio data

Table 26 Multiband Compressor (MBC) Control

DYNAMIC RANGE CONTROL (DRC)

The Dynamic Range Control (DRC) is a circuit which can be enabled in the digital playback or digital record paths of the WM8958 audio interfaces. The function of the DRC is to adjust the signal gain in conditions where the input amplitude is unknown or varies over a wide range, e.g. when recording from microphones built into a handheld system.

The DRC can apply Compression and Automatic Level Control to the signal path. It incorporates 'anti-clip' and 'quick release' features for handling transients in order to improve intelligibility in the presence of loud impulsive noises.

The DRC also incorporates a Noise Gate function, which provides additional attenuation of very low-level input signals. This means that the signal path is quiet when no signal is present, giving an improvement in background noise level under these conditions.

The WM8958 provides three stereo Dynamic Range Controllers (DRCs); these are associated with AIF1 timeslot 0, AIF1 timeslot 1 and AIF2 respectively. Each DRC can be enabled either in the DAC playback (AIF input) path or in the ADC record (AIF output) path, as described in the "Digital Core Architecture" section.

The DRCs are enabled in the DAC or ADCs audio signal paths using the register bits described in Table 27. Note that enabling any DRC in the DAC and ADC paths simultaneously is an invalid selection.

A Multiband Compressor (MBC) function is also available on the digital playback paths. Note that the DRC and MBC functions should not be enabled simultaneously on the same playback path. The MBC control registers are described in Table 26.

When the DRC is enabled in any of the ADC (digital record) paths, the associated High Pass Filter (HPF) must be enabled also; this ensures that DC offsets are removed prior to the DRC processing. The output path HPF control registers are described in Table 41 (for AIF1 output paths) and Table 49 (for AIF2 output paths). These are described in the "Digital Volume and Filter Control" section.

Note that, when ultrasonic (4FS) mode is selected on AIF1, then the DRC function is bypassed on the respective ADC (output) signal paths. The DRC may still be selected on the AIF1 DAC (input) signal paths.

REGISTER ADDRESS	BIT	LABEL	DEFAULT	DESCRIPTION
R1088 (0440h) AIF1 DRC1 (1)	2	AIF1DAC1_DRC_ENA	0	Enable DRC in AIF1DAC1 playback path (AIF1, Timeslot 0) 0 = Disabled 1 = Enabled
	1	AIF1ADC1L_DR_C_ENA	0	Enable DRC in AIF1ADC1 (Left) record path (AIF1, Timeslot 0) 0 = Disabled 1 = Enabled
	0	AIF1ADC1R_DR_C_ENA	0	Enable DRC in AIF1ADC1 (Right) record path (AIF1, Timeslot 0) 0 = Disabled 1 = Enabled
R1104 (0450h) AIF1 DRC2 (1)	2	AIF1DAC2_DRC_ENA	0	Enable DRC in AIF1DAC2 playback path (AIF1, Timeslot 1) 0 = Disabled 1 = Enabled
	1	AIF1ADC2L_DR_C_ENA	0	Enable DRC in AIF1ADC2 (Left) record path (AIF1, Timeslot 1) 0 = Disabled 1 = Enabled
	0	AIF1ADC2R_DR_C_ENA	0	Enable DRC in AIF1ADC2 (Right) record path (AIF1, Timeslot 1) 0 = Disabled 1 = Enabled

REGISTER ADDRESS	BIT	LABEL	DEFAULT	DESCRIPTION
R1344 (0540h) AIF2 DRC (1)	2	AIF2DAC_DRC_ENA	0	Enable DRC in AIF2DAC playback path 0 = Disabled 1 = Enabled
	1	AIF2ADCL_DRC_ENA	0	Enable DRC in AIF2ADC (Left) record path 0 = Disabled 1 = Enabled
	0	AIF2ADCR_DRC_ENA	0	Enable DRC in AIF2ADC (Right) record path 0 = Disabled 1 = Enabled

Table 27 DRC Enable

The following description of the DRC is applicable to all three DRCs. The associated register control fields are described in Table 29, Table 30 and Table 31 for the respective DRCs.

Note that, where the following description refers to register names, the generic prefix *[DRC]* is quoted:

- For the DRC associated with AIF1 timeslot 0, *[DRC]* = AIF1DRC1.
- For the DRC associated with AIF1 timeslot 1, *[DRC]* = AIF1DRC2.
- For the DRC associated with AIF2, *[DRC]* = AIF2DRC.

DRC COMPRESSION / EXPANSION / LIMITING

The DRC supports two different compression regions, separated by a “Knee” at a specific input amplitude. In the region above the knee, the compression slope *[DRC]_HI_COMP* applies; in the region below the knee, the compression slope *[DRC]_LO_COMP* applies.

The DRC also supports a noise gate region, where low-level input signals are heavily attenuated. This function can be enabled or disabled according to the application requirements. The DRC response in this region is defined by the expansion slope *[DRC]_NG_EXP*.

For additional attenuation of signals in the noise gate region, an additional “knee” can be defined (shown as “Knee2” in Figure 23). When this knee is enabled, this introduces an infinitely steep drop-off in the DRC response pattern between the *[DRC]_LO_COMP* and *[DRC]_NG_EXP* regions.

The overall DRC compression characteristic in “steady state” (i.e. where the input amplitude is near-constant) is illustrated in Figure 23.

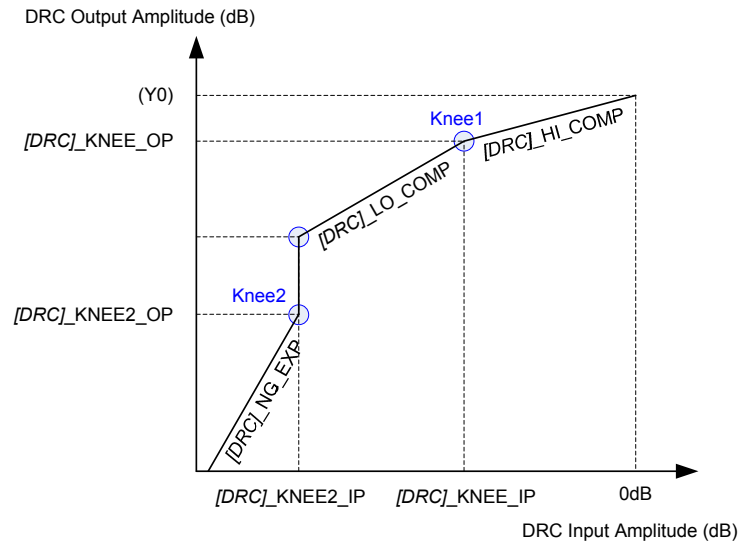

Figure 23 DRC Response Characteristic

The slope of the DRC response is determined by register fields *[DRC]_HI_COMP* and *[DRC]_LO_COMP*. A slope of 1 indicates constant gain in this region. A slope less than 1 represents compression (i.e. a change in input amplitude produces only a smaller change in output amplitude). A slope of 0 indicates that the target output amplitude is the same across a range of input amplitudes; this is infinite compression.

When the noise gate is enabled, the DRC response in this region is determined by the *[DRC]_NG_EXP* register. A slope of 1 indicates constant gain in this region. A slope greater than 1 represents expansion (ie. a change in input amplitude produces a larger change in output amplitude).

When the *DRC_KNEE2_OP* knee is enabled (“Knee2” in Figure 23), this introduces the vertical line in the response pattern illustrated, resulting in infinitely steep attenuation at this point in the response.

The DRC parameters are listed in Table 28.

REF	PARAMETER	DESCRIPTION
1	<i>[DRC]_KNEE_IP</i>	Input level at Knee1 (dB)
2	<i>[DRC]_KNEE_OP</i>	Output level at Knee2 (dB)
3	<i>[DRC]_HI_COMP</i>	Compression ratio above Knee1
4	<i>[DRC]_LO_COMP</i>	Compression ratio below Knee1
5	<i>[DRC]_KNEE2_IP</i>	Input level at Knee2 (dB)
6	<i>[DRC]_NG_EXP</i>	Expansion ratio below Knee2
7	<i>[DRC]_KNEE2_OP</i>	Output level at Knee2 (dB)

Table 28 DRC Response Parameters

The noise gate is enabled when the *[DRC]_NG_ENA* register is set. When the noise gate is not enabled, parameters 5, 6, 7 above are ignored, and the *[DRC]_LO_COMP* slope applies to all input signal levels below Knee1.

The *DRC_KNEE2_OP* knee is enabled when the *[DRC]_KNEE2_OP_ENA* register is set. When this bit is not set, then parameter 7 above is ignored, and the Knee2 position always coincides with the low end of the *[DRC]_LO_COMP* region.

The “Knee1” point in Figure 23 is determined by register fields *[DRC]_KNEE_IP* and *[DRC]_KNEE_OP*.

Parameter Y0, the output level for a 0dB input, is not specified directly, but can be calculated from the other parameters, using the equation:

$$Y0 = [DRC]_KNEE_OP - ([DRC]_KNEE_IP * [DRC]_HI_COMP)$$

GAIN LIMITS

The minimum and maximum gain applied by the DRC is set by register fields *[DRC]_MINGAIN*, *[DRC]_MAXGAIN* and *[DRC]_NG_MINGAIN*. These limits can be used to alter the DRC response from that illustrated in Figure 23. If the range between maximum and minimum gain is reduced, then the extent of the dynamic range control is reduced.

The minimum gain in the Compression regions of the DRC response is set by *[DRC]_MINGAIN*. The minimum gain in the Noise Gate region is set by *[DRC]_NG_MINGAIN*. The minimum gain limit prevents excessive attenuation of the signal path.

The maximum gain limit set by *[DRC]_MAXGAIN* prevents quiet signals (or silence) from being excessively amplified.

DYNAMIC CHARACTERISTICS

The dynamic behaviour determines how quickly the DRC responds to changing signal levels. Note that the DRC responds to the average (RMS) signal amplitude over a period of time.

The *[DRC]_ATK* determines how quickly the DRC gain decreases when the signal amplitude is high. The *[DRC]_DCY* determines how quickly the DRC gain increases when the signal amplitude is low.

These register fields are described in Table 29, Table 30 and Table 31. Note that the register defaults are suitable for general purpose microphone use.

ANTI-CLIP CONTROL

The DRC includes an Anti-Clip feature to avoid signal clipping when the input amplitude rises very quickly. This feature uses a feed-forward technique for early detection of a rising signal level. Signal clipping is avoided by dynamically increasing the gain attack rate when required. The Anti-Clip feature is enabled using the *[DRC]_ANTICLIP* bit.

Note that the feed-forward processing increases the latency in the input signal path.

Note that the Anti-Clip feature operates entirely in the digital domain. It cannot be used to prevent signal clipping in the analogue domain nor in the source signal. Analogue clipping can only be prevented by reducing the analogue signal gain or by adjusting the source signal.

Note that the Anti-Clip feature should not be enabled at the same time as the Quick Release feature (described below) on the same DRC.

QUICK RELEASE CONTROL

The DRC includes a Quick-Release feature to handle short transient peaks that are not related to the intended source signal. For example, in handheld microphone recording, transient signal peaks sometimes occur due to user handling, key presses or accidental tapping against the microphone. The Quick Release feature ensures that these transients do not cause the intended signal to be masked by the longer time constants of *[DRC]_DCY*.

The Quick-Release feature is enabled by setting the *[DRC]_QR* bit. When this bit is enabled, the DRC measures the crest factor (peak to RMS ratio) of the input signal. A high crest factor is indicative of a transient peak that may not be related to the intended source signal. If the crest factor exceeds the level set by *[DRC]_QR_THR*, then the normal decay rate (*[DRC]_DCY*) is ignored and a faster decay rate (*[DRC]_QR_DCY*) is used instead.

Note that the Quick Release feature should not be enabled at the same time as the Anti-Clip feature (described above) on the same DRC.

SIGNAL ACTIVITY DETECT

The DRC incorporates a configurable signal detect function, allowing the signal level at the DRC input to be monitored and to be used to trigger other events. This can be used to detect the presence of a microphone signal on an ADC or digital mic channel, or can be used to detect an audio signal received over the digital audio interface.

The Peak signal level or the RMS signal level of the DRC input can be selected as the detection threshold. When the threshold condition is exceeded, an interrupt or GPIO output can be generated. See "General Purpose Input/Output" for a full description of the applicable control fields.

DRC REGISTER CONTROLS

The AIF1DRC1 control registers are described in Table 29. The AIF1DRC2 control registers are described in Table 30. The AIF2DRC control registers are described in Table 31.

REGISTER ADDRESS	BIT	LABEL	DEFAULT	DESCRIPTION
R1088 (0440h) AIF1 DRC1 (1)	8	AIF1DRC1_NG_ENA	0	AIF1 DRC1 Noise Gate Enable 0 = Disabled 1 = Enabled
	5	AIF1DRC1_KNEE2_OP_ENA	0	AIF1 DRC1 KNEE2_OP Enable 0 = Disabled 1 = Enabled
	4	AIF1DRC1_QR	1	AIF1 DRC1 Quick-release Enable 0 = Disabled 1 = Enabled
	3	AIF1DRC1_ANTI_CLIP	1	AIF1 DRC1 Anti-clip Enable 0 = Disabled 1 = Enabled

REGISTER ADDRESS	BIT	LABEL	DEFAULT	DESCRIPTION
R1089 (0441h) AIF1 DRC1 (2)	12:9	AIF1DRC1_ATK [3:0]	0100	AIF1 DRC1 Gain attack rate (seconds/6dB) 0000 = Reserved 0001 = 181us 0010 = 363us 0011 = 726us 0100 = 1.45ms 0101 = 2.9ms 0110 = 5.8ms 0111 = 11.6ms 1000 = 23.2ms 1001 = 46.4ms 1010 = 92.8ms 1011 = 185.6ms 1100-1111 = Reserved
	8:5	AIF1DRC1_DCY [3:0]	0010	AIF1 DRC1 Gain decay rate (seconds/6dB) 0000 = 186ms 0001 = 372ms 0010 = 743ms 0011 = 1.49s 0100 = 2.97s 0101 = 5.94s 0110 = 11.89s 0111 = 23.78s 1000 = 47.56s 1001-1111 = Reserved
	4:2	AIF1DRC1_MIN GAIN [2:0]	001	AIF1 DRC1 Minimum gain to attenuate audio signals 000 = 0dB 001 = -12dB (default) 010 = -18dB 011 = -24dB 100 = -36dB 101 = Reserved 11X = Reserved
	1:0	AIF1DRC1_MAX GAIN [1:0]	01	AIF1 DRC1 Maximum gain to boost audio signals (dB) 00 = 12dB 01 = 18dB 10 = 24dB 11 = 36dB

REGISTER ADDRESS	BIT	LABEL	DEFAULT	DESCRIPTION
R1090 (0442h) AIF1 DRC1 (3)	15:12	AIF1DRC1_NG_MINGAIN [3:0]	0000	AIF1 DRC1 Minimum gain to attenuate audio signals when the noise gate is active. 0000 = -36dB 0001 = -30dB 0010 = -24dB 0011 = -18dB 0100 = -12dB 0101 = -6dB 0110 = 0dB 0111 = 6dB 1000 = 12dB 1001 = 18dB 1010 = 24dB 1011 = 30dB 1100 = 36dB 1101 to 1111 = Reserved
	11:10	AIF1DRC1_NG_EXP [1:0]	00	AIF1 DRC1 Noise Gate slope 00 = 1 (no expansion) 01 = 2 10 = 4 11 = 8
	9:8	AIF1DRC1_QR_THR [1:0]	00	AIF1 DRC1 Quick-release threshold (crest factor in dB) 00 = 12dB 01 = 18dB 10 = 24dB 11 = 30dB
	7:6	AIF1DRC1_QR_DCY [1:0]	00	AIF1 DRC1 Quick-release decay rate (seconds/6dB) 00 = 0.725ms 01 = 1.45ms 10 = 5.8ms 11 = Reserved
	5:3	AIF1DRC1_HI_COMP [2:0]	000	AIF1 DRC1 Compressor slope (upper region) 000 = 1 (no compression) 001 = 1/2 010 = 1/4 011 = 1/8 100 = 1/16 101 = 0 110 = Reserved 111 = Reserved
	2:0	AIF1DRC1_LO_COMP [2:0]	000	AIF1 DRC1 Compressor slope (lower region) 000 = 1 (no compression) 001 = 1/2 010 = 1/4 011 = 1/8 100 = 0 101 = Reserved 11X = Reserved

REGISTER ADDRESS	BIT	LABEL	DEFAULT	DESCRIPTION
R1091 (0443h) AIF1 DRC1 (4)	10:5	AIF1DRC1_KNE E_IP [5:0]	000000	AIF1 DRC1 Input signal level at the Compressor 'Knee'. 000000 = 0dB 000001 = -0.75dB 000010 = -1.5dB ... (-0.75dB steps) 111100 = -45dB 111101 = Reserved 11111X = Reserved
	4:0	AIF1DRC1_KNE E_OP [4:0]	00000	AIF1 DRC1 Output signal at the Compressor 'Knee'. 00000 = 0dB 00001 = -0.75dB 00010 = -1.5dB ... (-0.75dB steps) 11110 = -22.5dB 11111 = Reserved
R1092 (0444h) AIF1 DRC1 (5)	9:5	AIF1DRC1_KNE E2_IP [4:0]	00000	AIF1 DRC1 Input signal level at the Noise Gate threshold 'Knee2'. 00000 = -36dB 00001 = -37.5dB 00010 = -39dB ... (-1.5dB steps) 11110 = -81dB 11111 = -82.5dB Only applicable when AIF1DRC1_NG_ENA = 1.
	4:0	AIF1DRC1_KNE E2_OP [4:0]	00000	AIF1 DRC1 Output signal at the Noise Gate threshold 'Knee2'. 00000 = -30dB 00001 = -31.5dB 00010 = -33dB ... (-1.5dB steps) 11110 = -75dB 11111 = -76.5dB Only applicable when AIF1DRC1_KNEE2_OP_ENA = 1.

Table 29 AIF1 Timeslot 0 DRC Controls

REGISTER ADDRESS	BIT	LABEL	DEFAULT	DESCRIPTION
R1104 (0450h) AIF1 DRC2 (1)	8	AIF1DRC2_NG_ ENA	0	AIF1 DRC2 Noise Gate Enable 0 = Disabled 1 = Enabled
	5	AIF1DRC2_KNE E2_OP_ENA	0	AIF1 DRC2 KNEE2_OP Enable 0 = Disabled 1 = Enabled
	4	AIF1DRC2_QR	1	AIF1 DRC2 Quick-release Enable 0 = Disabled 1 = Enabled
	3	AIF1DRC2_ANTI CLIP	1	AIF1 DRC2 Anti-clip Enable 0 = Disabled 1 = Enabled

REGISTER ADDRESS	BIT	LABEL	DEFAULT	DESCRIPTION
R1105 (0451h) AIF1 DRC2 (2)	12:9	AIF1DRC2_ATK [3:0]	0100	AIF1 DRC2 Gain attack rate (seconds/6dB) 0000 = Reserved 0001 = 181us 0010 = 363us 0011 = 726us 0100 = 1.45ms 0101 = 2.9ms 0110 = 5.8ms 0111 = 11.6ms 1000 = 23.2ms 1001 = 46.4ms 1010 = 92.8ms 1011 = 185.6ms 1100-1111 = Reserved
	8:5	AIF1DRC2_DCY [3:0]	0010	AIF1 DRC2 Gain decay rate (seconds/6dB) 0000 = 186ms 0001 = 372ms 0010 = 743ms 0011 = 1.49s 0100 = 2.97s 0101 = 5.94s 0110 = 11.89s 0111 = 23.78s 1000 = 47.56s 1001-1111 = Reserved
	4:2	AIF1DRC2_MIN GAIN [2:0]	001	AIF1 DRC2 Minimum gain to attenuate audio signals 000 = 0dB 001 = -12dB (default) 010 = -18dB 011 = -24dB 100 = -36dB 101 = Reserved 11X = Reserved
	1:0	AIF1DRC2_MAX GAIN [1:0]	01	AIF1 DRC2 Maximum gain to boost audio signals (dB) 00 = 12dB 01 = 18dB 10 = 24dB 11 = 36dB

REGISTER ADDRESS	BIT	LABEL	DEFAULT	DESCRIPTION
R1106 (0452h) AIF1 DRC2 (3)	15:12	AIF1DRC2_NG_MINGAIN [3:0]	0000	AIF1 DRC2 Minimum gain to attenuate audio signals when the noise gate is active. 0000 = -36dB 0001 = -30dB 0010 = -24dB 0011 = -18dB 0100 = -12dB 0101 = -6dB 0110 = 0dB 0111 = 6dB 1000 = 12dB 1001 = 18dB 1010 = 24dB 1011 = 30dB 1100 = 36dB 1101 to 1111 = Reserved
	11:10	AIF1DRC2_NG_EXP [1:0]	00	AIF1 DRC2 Noise Gate slope 00 = 1 (no expansion) 01 = 2 10 = 4 11 = 8
	9:8	AIF1DRC2_QR_THR [1:0]	00	AIF1 DRC2 Quick-release threshold (crest factor in dB) 00 = 12dB 01 = 18dB 10 = 24dB 11 = 30dB
	7:6	AIF1DRC2_QR_DCY [1:0]	00	AIF1 DRC2 Quick-release decay rate (seconds/6dB) 00 = 0.725ms 01 = 1.45ms 10 = 5.8ms 11 = Reserved
	5:3	AIF1DRC2_HI_COMP [2:0]	000	AIF1 DRC2 Compressor slope (upper region) 000 = 1 (no compression) 001 = 1/2 010 = 1/4 011 = 1/8 100 = 1/16 101 = 0 110 = Reserved 111 = Reserved
	2:0	AIF1DRC2_LO_COMP [2:0]	000	AIF1 DRC2 Compressor slope (lower region) 000 = 1 (no compression) 001 = 1/2 010 = 1/4 011 = 1/8 100 = 0 101 = Reserved 11X = Reserved

REGISTER ADDRESS	BIT	LABEL	DEFAULT	DESCRIPTION
R1107 (0453h) AIF1 DRC2 (4)	10:5	AIF1DRC2_KNE E_IP [5:0]	000000	AIF1 DRC2 Input signal level at the Compressor 'Knee'. 000000 = 0dB 000001 = -0.75dB 000010 = -1.5dB ... (-0.75dB steps) 111100 = -45dB 111101 = Reserved 11111X = Reserved
	4:0	AIF1DRC2_KNE E_OP [4:0]	00000	AIF1 DRC2 Output signal at the Compressor 'Knee'. 00000 = 0dB 00001 = -0.75dB 00010 = -1.5dB ... (-0.75dB steps) 11110 = -22.5dB 11111 = Reserved
R1108 (0454h) AIF1 DRC2 (5)	9:5	AIF1DRC2_KNE E2_IP [4:0]	00000	AIF1 DRC2 Input signal level at the Noise Gate threshold 'Knee2'. 00000 = -36dB 00001 = -37.5dB 00010 = -39dB ... (-1.5dB steps) 11110 = -81dB 11111 = -82.5dB Only applicable when AIF1DRC2_NG_ENA = 1.
	4:0	AIF1DRC2_KNE E2_OP [4:0]	00000	AIF1 DRC2 Output signal at the Noise Gate threshold 'Knee2'. 00000 = -30dB 00001 = -31.5dB 00010 = -33dB ... (-1.5dB steps) 11110 = -75dB 11111 = -76.5dB Only applicable when AIF1DRC2_KNEE2_OP_ENA = 1.

Table 30 AIF1 Timeslot 1 DRC Controls

REGISTER ADDRESS	BIT	LABEL	DEFAULT	DESCRIPTION
R1344 (0540h) AIF2 DRC (1)	8	AIF2DRC_NG_ENA	0	AIF2 DRC Noise Gate Enable 0 = Disabled 1 = Enabled
	5	AIF2DRC_KNEE2_OP_ENA	0	AIF2 DRC KNEE2_OP Enable 0 = Disabled 1 = Enabled
	4	AIF2DRC_QR	1	AIF2 DRC Quick-release Enable 0 = Disabled 1 = Enabled
	3	AIF2DRC_ANTI_CLIP	1	AIF2 DRC Anti-clip Enable 0 = Disabled 1 = Enabled

REGISTER ADDRESS	BIT	LABEL	DEFAULT	DESCRIPTION
R1345 (0541h) AIF2 DRC (2)	12:9	AIF2DRC_ATK [3:0]	0100	AIF2 DRC Gain attack rate (seconds/6dB) 0000 = Reserved 0001 = 181us 0010 = 363us 0011 = 726us 0100 = 1.45ms 0101 = 2.9ms 0110 = 5.8ms 0111 = 11.6ms 1000 = 23.2ms 1001 = 46.4ms 1010 = 92.8ms 1011 = 185.6ms 1100-1111 = Reserved
	8:5	AIF2DRC_DCY [3:0]	0010	AIF2 DRC Gain decay rate (seconds/6dB) 0000 = 186ms 0001 = 372ms 0010 = 743ms 0011 = 1.49s 0100 = 2.97s 0101 = 5.94s 0110 = 11.89s 0111 = 23.78s 1000 = 47.56s 1001-1111 = Reserved
	4:2	AIF2DRC_MINING AIN [2:0]	001	AIF2 DRC Minimum gain to attenuate audio signals 000 = 0dB 001 = -12dB (default) 010 = -18dB 011 = -24dB 100 = -36dB 101 = Reserved 11X = Reserved
	1:0	AIF2DRC_MAX GAIN [1:0]	01	AIF2 DRC Maximum gain to boost audio signals (dB) 00 = 12dB 01 = 18dB 10 = 24dB 11 = 36dB

REGISTER ADDRESS	BIT	LABEL	DEFAULT	DESCRIPTION
R1346 (0542h) AIF2 DRC (3)	15:12	AIF2DRC_NG_MINGAIN [3:0]	0000	AIF2 DRC Minimum gain to attenuate audio signals when the noise gate is active. 0000 = -36dB 0001 = -30dB 0010 = -24dB 0011 = -18dB 0100 = -12dB 0101 = -6dB 0110 = 0dB 0111 = 6dB 1000 = 12dB 1001 = 18dB 1010 = 24dB 1011 = 30dB 1100 = 36dB 1101 to 1111 = Reserved
	11:10	AIF2DRC_NG_EXP [1:0]	00	AIF2 DRC Noise Gate slope 00 = 1 (no expansion) 01 = 2 10 = 4 11 = 8
	9:8	AIF2DRC_QR_THR [1:0]	00	AIF2 DRC Quick-release threshold (crest factor in dB) 00 = 12dB 01 = 18dB 10 = 24dB 11 = 30dB
	7:6	AIF2DRC_QR_DECY [1:0]	00	AIF2 DRC Quick-release decay rate (seconds/6dB) 00 = 0.725ms 01 = 1.45ms 10 = 5.8ms 11 = Reserved
	5:3	AIF2DRC_HI_COMP [2:0]	000	AIF2 DRC Compressor slope (upper region) 000 = 1 (no compression) 001 = 1/2 010 = 1/4 011 = 1/8 100 = 1/16 101 = 0 110 = Reserved 111 = Reserved
	2:0	AIF2DRC_LO_COMP [2:0]	000	AIF2 DRC Compressor slope (lower region) 000 = 1 (no compression) 001 = 1/2 010 = 1/4 011 = 1/8 100 = 0 101 = Reserved 11X = Reserved

REGISTER ADDRESS	BIT	LABEL	DEFAULT	DESCRIPTION
R1347 (0543h) AIF2 DRC (4)	10:5	AIF2DRC_KNEE_IP [5:0]	000000	AIF2 DRC Input signal level at the Compressor 'Knee'. 000000 = 0dB 000001 = -0.75dB 000010 = -1.5dB ... (-0.75dB steps) 111100 = -45dB 111101 = Reserved 11111X = Reserved
	4:0	AIF2DRC_KNEE_OP [4:0]	00000	AIF2 DRC Output signal at the Compressor 'Knee'. 00000 = 0dB 00001 = -0.75dB 00010 = -1.5dB ... (-0.75dB steps) 11110 = -22.5dB 11111 = Reserved
R1348 (0544h) AIF2 DRC (5)	9:5	AIF2DRC_KNEE2_IP [4:0]	00000	AIF2 DRC Input signal level at the Noise Gate threshold 'Knee2'. 00000 = -36dB 00001 = -37.5dB 00010 = -39dB ... (-1.5dB steps) 11110 = -81dB 11111 = -82.5dB Only applicable when AIF2DRC_NG_ENA = 1.
	4:0	AIF2DRC_KNEE2_OP [4:0]	00000	AIF2 DRC Output signal at the Noise Gate threshold 'Knee2'. 00000 = -30dB 00001 = -31.5dB 00010 = -33dB ... (-1.5dB steps) 11110 = -75dB 11111 = -76.5dB Only applicable when AIF2DRC_KNEE2_OP_ENA = 1.

Table 31 AIF2 DRC Controls

RETUNE™ MOBILE PARAMETRIC EQUALIZER (EQ)

The ReTune™ Mobile Parametric EQ is a circuit which can be enabled in the digital playback path of the WM8958 audio interfaces. The function of the EQ is to adjust the frequency characteristic of the output in order to compensate for unwanted frequency characteristics in the loudspeaker (or other output transducer). It can also be used to tailor the response according to user preferences, for example to accentuate or attenuate specific frequency bands to emulate different sound profiles or environments e.g. concert hall, rock etc.

The WM8958 provides three stereo EQ circuits; these are associated with AIF1 timeslot 0, AIF1 timeslot 1 and AIF2 respectively. The EQ is enabled in these three signal paths using the register bits described in Table 32.

REGISTER ADDRESS	BIT	LABEL	DEFAULT	DESCRIPTION
R1152 (0480h) AIF1 DAC1 EQ Gains (1)	0	AIF1DAC1_EQ_ENA	0	Enable EQ in AIF1DAC1 playback path (AIF1, Timeslot 0) 0 = Disabled 1 = Enabled
R1184 (04A0h) AIF1 DAC2 EQ Gains (1)	0	AIF1DAC2_EQ_ENA	0	Enable EQ in AIF1DAC2 playback path (AIF1, Timeslot 1) 0 = Disabled 1 = Enabled
R1408 (0580h) AIF2 EQ Gains (1)	0	AIF2DAC_EQ_ENA	0	Enable EQ in AIF2DAC playback path 0 = Disabled 1 = Enabled

Table 32 ReTune™ Mobile Parametric EQ Enable

The following description of the EQ is applicable to all three EQ circuits. The associated register control fields are described in Table 34, Table 35 and Table 36 for the respective EQs. The EQ provides selective control of 5 frequency bands as described below.

The low frequency band (Band 1) filter can be configured either as a peak filter or a shelving filter. When configured as a shelving filter, it provides adjustable gain below the Band 1 cut-off frequency. As a peak filter, it provides adjustable gain within a defined frequency band that is centred on the Band 1 frequency.

The mid frequency bands (Band 2, Band 3, Band 4) filters are peak filters, which provide adjustable gain around the respective centre frequency.

The high frequency band (Band 5) filter is a shelving filter, which provides adjustable gain above the Band 5 cut-off frequency.

The EQ can be configured to operate in two modes - "Default" mode or "ReTune™ Mobile" mode.

DEFAULT MODE (5-BAND PARAMETRIC EQ)

In default mode, the cut-off / centre frequencies are fixed as per Table 33. The filter bandwidths are also fixed in default mode. The gain of the individual bands (-12dB to +12dB) can be controlled as described in Table 34.

The cut-off / centre frequencies noted in Table 33 are applicable to a sample rate of 48kHz. When using other sample rates, these frequencies will be scaled in proportion to the selected sample rate for the associated Audio Interface (AIF1 or AIF2).

If AIF1 and AIF2 are operating at different sample rates, then the cut-off / centre frequencies will be different for the two interfaces. Note that the frequencies can be set to other values by using the features described in "ReTune™ Mobile Mode".

EQ BAND	CUT-OFF/CENTRE FREQUENCY
1	100 Hz
2	300 Hz
3	875 Hz
4	2400 Hz
5	6900 Hz

Table 33 EQ Band Cut-off / Centre Frequencies

REGISTER ADDRESS	BIT	LABEL	DEFAULT	DESCRIPTION
R1152 (0480h) AIF1 DAC1 EQ Gains (1)	15:11	AIF1DAC1_EQ _B1_GAIN [4:0]	01100 (0dB)	AIF1DAC1 (AIF1, Timeslot 0) EQ Band 1 Gain -12dB to +12dB in 1dB steps (see Table 37 for gain range)
	10:6	AIF1DAC1_EQ _B2_GAIN [4:0]	01100 (0dB)	AIF1DAC1 (AIF1, Timeslot 0) EQ Band 2 Gain -12dB to +12dB in 1dB steps (see Table 37 for gain range)
	5:1	AIF1DAC1_EQ _B3_GAIN [4:0]	01100 (0dB)	AIF1DAC1 (AIF1, Timeslot 0) EQ Band 3 Gain -12dB to +12dB in 1dB steps (see Table 37 for gain range)
R1153 (0481h) AIF1 DAC1 EQ Gains (2)	15:11	AIF1DAC1_EQ _B4_GAIN [4:0]	01100 (0dB)	AIF1DAC1 (AIF1, Timeslot 0) EQ Band 4 Gain -12dB to +12dB in 1dB steps (see Table 37 for gain range)
	10:6	AIF1DAC1_EQ _B5_GAIN [4:0]	01100 (0dB)	AIF1DAC1 (AIF1, Timeslot 0) EQ Band 5 Gain -12dB to +12dB in 1dB steps (see Table 37 for gain range)
	0	AIF1DAC1_EQ _MODE	0	AIF1DAC1 (AIF1, Timeslot 0) EQ Band 1 Mode 0 = Shelving filter 1 = Peak filter

Table 34 AIF1 Timeslot 0 EQ Band Gain Control

REGISTER ADDRESS	BIT	LABEL	DEFAULT	DESCRIPTION
R1184 (04A0h) AIF1 DAC2 EQ Gains (1)	15:11	AIF1DAC2_EQ _B1_GAIN [4:0]	01100 (0dB)	AIF1DAC2 (AIF1, Timeslot 1) EQ Band 1 Gain -12dB to +12dB in 1dB steps (see Table 37 for gain range)
	10:6	AIF1DAC2_EQ _B2_GAIN [4:0]	01100 (0dB)	AIF1DAC2 (AIF1, Timeslot 1) EQ Band 2 Gain -12dB to +12dB in 1dB steps (see Table 37 for gain range)
	5:1	AIF1DAC2_EQ _B3_GAIN [4:0]	01100 (0dB)	AIF1DAC2 (AIF1, Timeslot 1) EQ Band 3 Gain -12dB to +12dB in 1dB steps (see Table 37 for gain range)
R1185 (04A1h) AIF1 DAC2 EQ Gains (2)	15:11	AIF1DAC2_EQ _B4_GAIN [4:0]	01100 (0dB)	AIF1DAC2 (AIF1, Timeslot 1) EQ Band 4 Gain -12dB to +12dB in 1dB steps (see Table 37 for gain range)
	10:6	AIF1DAC2_EQ _B5_GAIN [4:0]	01100 (0dB)	AIF1DAC2 (AIF1, Timeslot 1) EQ Band 5 Gain -12dB to +12dB in 1dB steps (see Table 37 for gain range)
	0	AIF1DAC2_EQ _MODE	0	AIF1DAC2 (AIF1, Timeslot 1) EQ Band 1 Mode 0 = Shelving filter 1 = Peak filter

Table 35 AIF1 Timeslot 1 EQ Band Gain Control

REGISTER ADDRESS	BIT	LABEL	DEFAULT	DESCRIPTION
R1408 (0580h) AIF2 EQ Gains (1)	15:11	AIF2DAC_EQ_ B1_GAIN [4:0]	01100 (0dB)	AIF2 EQ Band 1 Gain -12dB to +12dB in 1dB steps (see Table 37 for gain range)
	10:6	AIF2DAC_EQ_ B2_GAIN [4:0]	01100 (0dB)	AIF2 EQ Band 2 Gain -12dB to +12dB in 1dB steps (see Table 37 for gain range)
	5:1	AIF2DAC_EQ_ B3_GAIN [4:0]	01100 (0dB)	AIF2 EQ Band 3 Gain -12dB to +12dB in 1dB steps (see Table 37 for gain range)
R1409 (0581h) AIF2 EQ Gains (2)	15:11	AIF2DAC_EQ_ B4_GAIN [4:0]	01100 (0dB)	AIF2 EQ Band 4 Gain -12dB to +12dB in 1dB steps (see Table 37 for gain range)
	10:6	AIF2DAC_EQ_ B5_GAIN [4:0]	01100 (0dB)	AIF2 EQ Band 5 Gain -12dB to +12dB in 1dB steps (see Table 37 for gain range)
	0	AIF2DAC_EQ_ MODE	0	AIF2 EQ Band 1 Mode 0 = Shelving filter 1 = Peak filter

Table 36 AIF2 EQ Band Gain Control

EQ GAIN SETTING	GAIN (dB)
00000	-12
00001	-11
00010	-10
00011	-9
00100	-8
00101	-7
00110	-6
00111	-5
01000	-4
01001	-3
01010	-2
01011	-1
01100	0
01101	+1
01110	+2
01111	+3
10000	+4
10001	+5
10010	+6
10011	+7
10100	+8
10101	+9
10110	+10
10111	+11
11000	+12
11001 to 11111	Reserved

Table 37 EQ Gain Control Range

RETUNE™ MOBILE MODE

ReTune™ Mobile mode provides a comprehensive facility for the user to define the cut-off/centre frequencies and filter bandwidth for each EQ band, in addition to the gain controls already described. This enables the EQ to be accurately customised for a specific transducer characteristic or desired sound profile.

The EQ enable and EQ gain controls are the same as defined for the default mode. The additional coefficients used in ReTune™ Mobile mode are held in registers R1154 to R1172 for AIF1DAC1, registers R1186 to R1204 for AIF1DAC2 and registers R1410 to R1428 for AIF2. These coefficients are derived using tools provided in Wolfson's WISCE™ evaluation board control software.

Please contact your local Wolfson representative for more details.

Note that the WM8958 audio interfaces may operate at different sample rates concurrently. The EQ settings for each interface must be programmed relative to the applicable sample rate of the corresponding audio interface. If the audio interface sample rate is changed, then different EQ register settings will be required to achieve a given EQ response.

EQ FILTER CHARACTERISTICS

The filter characteristics for each frequency band are shown in Figure 24 to Figure 28. These figures show the frequency response for all available gain settings, using default cut-off/centre frequencies and bandwidth. Note that EQ Band 1 can also be configured as a Peak Filter if required.

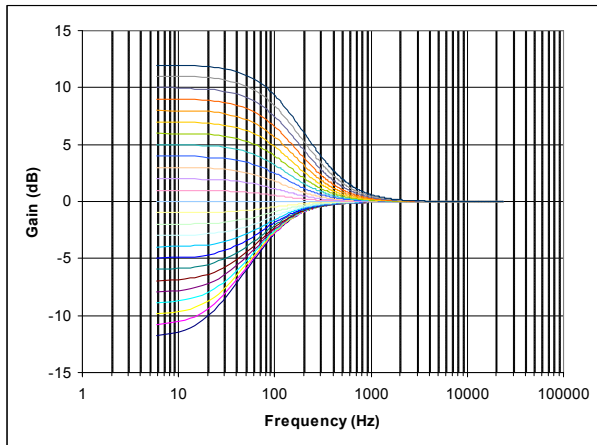

Figure 24 EQ Band 1 – Low Freq Shelf Filter Response

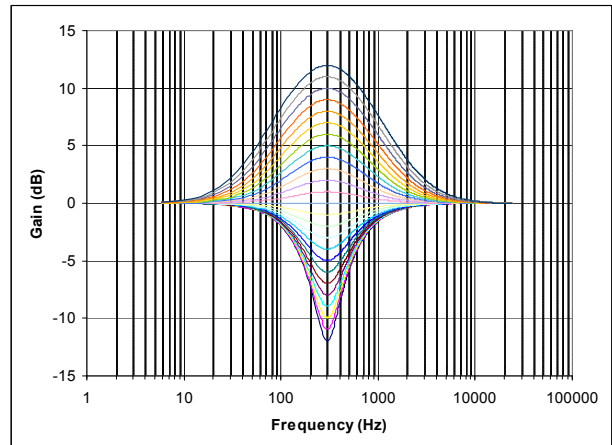

Figure 25 EQ Band 2 – Peak Filter Response

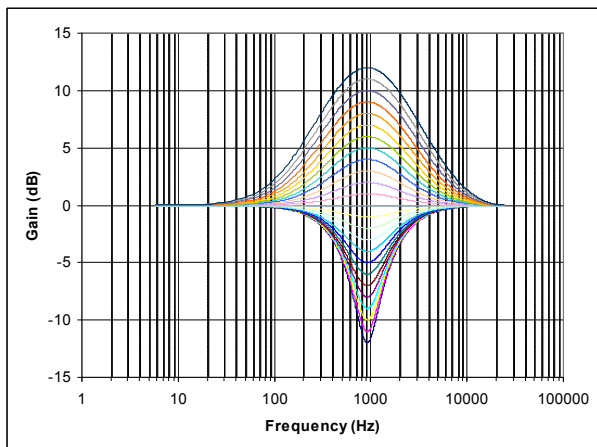

Figure 26 EQ Band 3 – Peak Filter Response

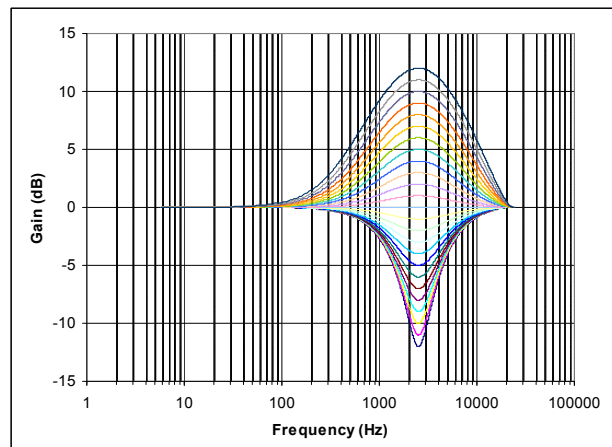

Figure 27 EQ Band 4 – Peak Filter Response

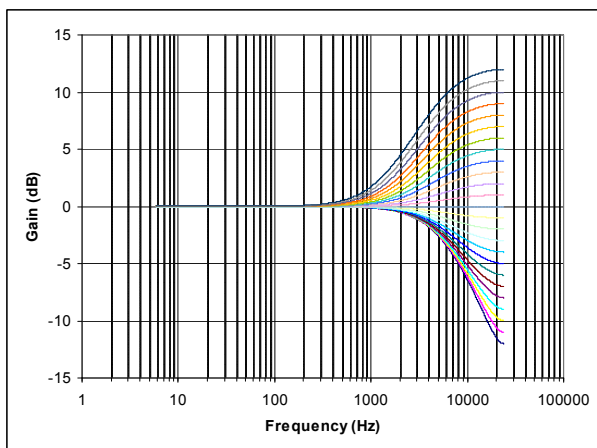

Figure 28 EQ Band 5 – High Freq Shelf Filter Response

3D STEREO EXPANSION

The 3D Stereo Expansion is an audio enhancement feature which can be enabled in the digital playback path of the WM8958 audio interfaces. This feature uses configurable cross-talk mechanisms to adjust the depth or width of the stereo audio.

The WM8958 provides three 3D Stereo Expansion circuits; these are associated with AIF1 timeslot 0, AIF1 timeslot 1 and AIF2 respectively. The 3D Stereo Expansion is enabled and controlled in these signal paths using the register bits described in Table 38.

REGISTER ADDRESS	BIT	LABEL	DEFAULT	DESCRIPTION
R1057 (0421h) AIF1 DAC1 Filters (2)	13:9	AIF1DAC1_3D_G AIN	00000	AIF1DAC1 playback path (AIF1, Timeslot 0) 3D Stereo depth 00000 = Off 00001 = Minimum (-16dB) ...(0.915dB steps) 11111 = Maximum (+11.45dB)
	8	AIF1DAC1_3D_E NA	0	Enable 3D Stereo in AIF1DAC1 playback path (AIF1, Timeslot 0) 0 = Disabled 1 = Enabled
R1059 (0423h) AIF1 DAC2 Filters (2)	13:9	AIF1DAC2_3D_G AIN	00000	AIF1DAC2 playback path (AIF1, Timeslot 1) 3D Stereo depth 00000 = Off 00001 = Minimum (-16dB) ...(0.915dB steps) 11111 = Maximum (+11.45dB)
	8	AIF1DAC2_3D_E NA	0	Enable 3D Stereo in AIF1DAC2 playback path (AIF1, Timeslot 1) 0 = Disabled 1 = Enabled
R1313 (0521h) AIF2 DAC Filters (2)	13:9	AIF2DAC_3D_GA IN	00000	AIF2DAC playback path 3D Stereo depth 00000 = Off 00001 = Minimum (-16dB) ...(0.915dB steps) 11111 = Maximum (+11.45dB)
	8	AIF2DAC_3D_EN A	0	Enable 3D Stereo in AIF2DAC playback path 0 = Disabled 1 = Enabled

Table 38 3D Stereo Expansion Control

DIGITAL VOLUME AND FILTER CONTROL

This section describes the digital volume and filter controls of the WM8958 AIF paths.

Digital volume control and High Pass Filter (HPF) control is provided on four AIF1 output (digital record) paths and two AIF2 output (digital record) paths.

Note that, when ultrasonic (4FS) mode is selected on AIF1, then the digital volume control and high pass filter (HPF) control are bypassed on the respective ADC (output) signal paths.

Digital volume, soft-mute and mono mix control is provided on four AIF1 input (digital playback) paths and two AIF2 input (digital playback) paths. A configurable noise gate function is available on each of the digital playback paths.

AIF1 - OUTPUT PATH VOLUME CONTROL

The AIF1 interface supports up to four output channels. A digital volume control is provided on each of these output signal paths, allowing attenuation in the range -71.625dB to +17.625dB in 0.375dB steps. The level of attenuation for an eight-bit code X is given by:

$$0.375 \times (X-192) \text{ dB for } 1 \leq X \leq 239; \quad \text{MUTE for } X = 0 \quad +17.625\text{dB for } 239 \leq X \leq 255$$

The AIF1ADC1_VU and AIF1ADC2_VU bits control the loading of digital volume control data. When the volume update bit is set to 0, the associated volume control data will be loaded into the respective control register, but will not actually change the digital gain setting.

The AIF1ADC1L and AIF1ADC1R gain settings are updated when a 1 is written to AIF1ADC1_VU. The AIF1ADC2L and AIF1ADC2R gain settings are updated when a 1 is written to AIF1ADC2_VU. This makes it possible to update the gain of left and right channels simultaneously.

REGISTER ADDRESS	BIT	LABEL	DEFAULT	DESCRIPTION
R1024 (0400h) AIF1 ADC1 Left Volume	8	AIF1ADC1_VU	N/A	AIF1ADC1 output path (AIF1, Timeslot 0) Volume Update Writing a 1 to this bit will cause the AIF1ADC1L and AIF1ADC1R volume to be updated simultaneously
	7:0	AIF1ADC1L_VOL [7:0]	C0h (0dB)	AIF1ADC1 (Left) output path (AIF1, Timeslot 0) Digital Volume 00h = MUTE 01h = -71.625dB ... (0.375dB steps) EFh = +17.625dB (See Table 40 for volume range)
R1025 (0401h) AIF1 ADC1 Right Volume	8	AIF1ADC1_VU	N/A	AIF1ADC1 output path (AIF1, Timeslot 0) Volume Update Writing a 1 to this bit will cause the AIF1ADC1L and AIF1ADC1R volume to be updated simultaneously
	7:0	AIF1ADC1R_VOL [7:0]	C0h (0dB)	AIF1ADC1 (Right) output path (AIF1, Timeslot 0) Digital Volume 00h = MUTE 01h = -71.625dB ... (0.375dB steps) EFh = +17.625dB (See Table 40 for volume range)
R1028 (0404h) AIF1 ADC2 Left Volume	8	AIF1ADC2_VU	N/A	AIF1ADC2 output path (AIF1, Timeslot 1) Volume Update Writing a 1 to this bit will cause the AIF1ADC2L and AIF1ADC2R volume to be updated simultaneously

REGISTER ADDRESS	BIT	LABEL	DEFAULT	DESCRIPTION
	7:0	AIF1ADC2L_VOL [7:0]	C0h (0dB)	AIF1ADC2 (Left) output path (AIF1, Timeslot 1) Digital Volume 00h = MUTE 01h = -71.625dB ... (0.375dB steps) EFh = +17.625dB (See Table 40 for volume range)
R1029 (0405h) AIF1 ADC2 Right Volume	8	AIF1ADC2_VU	N/A	AIF1ADC2 output path (AIF1, Timeslot 1) Volume Update Writing a 1 to this bit will cause the AIF1ADC2L and AIF1ADC2R volume to be updated simultaneously
	7:0	AIF1ADC2R_VOL [7:0]	C0h (0dB)	AIF1ADC2 (Right) output path (AIF1, Timeslot 1) Digital Volume 00h = MUTE 01h = -71.625dB ... (0.375dB steps) EFh = +17.625dB (See Table 40 for volume range)

Table 39 AIF1 Output Path Volume Control

AIF1/AIF2 Output Volume	Volume (dB)	AIF1/AIF2 Output Volume	Volume (dB)	AIF1/AIF2 Output Volume	Volume (dB)	AIF1/AIF2 Output Volume	Volume (dB)
0h	MUTE	40h	-48.000	80h	-24.000	C0h	0.000
1h	-71.625	41h	-47.625	81h	-23.625	C1h	0.375
2h	-71.250	42h	-47.250	82h	-23.250	C2h	0.750
3h	-70.875	43h	-46.875	83h	-22.875	C3h	1.125
4h	-70.500	44h	-46.500	84h	-22.500	C4h	1.500
5h	-70.125	45h	-46.125	85h	-22.125	C5h	1.875
6h	-69.750	46h	-45.750	86h	-21.750	C6h	2.250
7h	-69.375	47h	-45.375	87h	-21.375	C7h	2.625
8h	-69.000	48h	-45.000	88h	-21.000	C8h	3.000
9h	-68.625	49h	-44.625	89h	-20.625	C9h	3.375
Ah	-68.250	4Ah	-44.250	8Ah	-20.250	CAh	3.750
Bh	-67.875	4Bh	-43.875	8Bh	-19.875	CBh	4.125
Ch	-67.500	4Ch	-43.500	8Ch	-19.500	CCh	4.500
Dh	-67.125	4Dh	-43.125	8Dh	-19.125	CDh	4.875
Eh	-66.750	4Eh	-42.750	8Eh	-18.750	CEh	5.250
Fh	-66.375	4Fh	-42.375	8Fh	-18.375	CFh	5.625
10h	-66.000	50h	-42.000	90h	-18.000	D0h	6.000
11h	-65.625	51h	-41.625	91h	-17.625	D1h	6.375
12h	-65.250	52h	-41.250	92h	-17.250	D2h	6.750
13h	-64.875	53h	-40.875	93h	-16.875	D3h	7.125
14h	-64.500	54h	-40.500	94h	-16.500	D4h	7.500
15h	-64.125	55h	-40.125	95h	-16.125	D5h	7.875
16h	-63.750	56h	-39.750	96h	-15.750	D6h	8.250
17h	-63.375	57h	-39.375	97h	-15.375	D7h	8.625
18h	-63.000	58h	-39.000	98h	-15.000	D8h	9.000
19h	-62.625	59h	-38.625	99h	-14.625	D9h	9.375
1Ah	-62.250	5Ah	-38.250	9Ah	-14.250	DAh	9.750
1Bh	-61.875	5Bh	-37.875	9Bh	-13.875	DBh	10.125
1Ch	-61.500	5Ch	-37.500	9Ch	-13.500	DCh	10.500
1Dh	-61.125	5Dh	-37.125	9Dh	-13.125	DDh	10.875
1Eh	-60.750	5Eh	-36.750	9Eh	-12.750	DEh	11.250
1Fh	-60.375	5Fh	-36.375	9Fh	-12.375	DFh	11.625
20h	-60.000	60h	-36.000	A0h	-12.000	E0h	12.000
21h	-59.625	61h	-35.625	A1h	-11.625	E1h	12.375
22h	-59.250	62h	-35.250	A2h	-11.250	E2h	12.750
23h	-58.875	63h	-34.875	A3h	-10.875	E3h	13.125
24h	-58.500	64h	-34.500	A4h	-10.500	E4h	13.500
25h	-58.125	65h	-34.125	A5h	-10.125	E5h	13.875
26h	-57.750	66h	-33.750	A6h	-9.750	E6h	14.250
27h	-57.375	67h	-33.375	A7h	-9.375	E7h	14.625
28h	-57.000	68h	-33.000	A8h	-9.000	E8h	15.000
29h	-56.625	69h	-32.625	A9h	-8.625	E9h	15.375
2Ah	-56.250	6Ah	-32.250	AAh	-8.250	EAh	15.750
2Bh	-55.875	6Bh	-31.875	ABh	-7.875	EBh	16.125
2Ch	-55.500	6Ch	-31.500	ACh	-7.500	ECh	16.500
2Dh	-55.125	6Dh	-31.125	ADh	-7.125	EDh	16.875
2Eh	-54.750	6Eh	-30.750	A Eh	-6.750	EEh	17.250
2Fh	-54.375	6Fh	-30.375	AFh	-6.375	EFh	17.625
30h	-54.000	70h	-30.000	B0h	-6.000	F0h	17.625
31h	-53.625	71h	-29.625	B1h	-5.625	F1h	17.625
32h	-53.250	72h	-29.250	B2h	-5.250	F2h	17.625
33h	-52.875	73h	-28.875	B3h	-4.875	F3h	17.625
34h	-52.500	74h	-28.500	B4h	-4.500	F4h	17.625
35h	-52.125	75h	-28.125	B5h	-4.125	F5h	17.625
36h	-51.750	76h	-27.750	B6h	-3.750	F6h	17.625
37h	-51.375	77h	-27.375	B7h	-3.375	F7h	17.625
38h	-51.000	78h	-27.000	B8h	-3.000	F8h	17.625
39h	-50.625	79h	-26.625	B9h	-2.625	F9h	17.625
3Ah	-50.250	7Ah	-26.250	BAh	-2.250	FAh	17.625
3Bh	-49.875	7Bh	-25.875	BBh	-1.875	FBh	17.625
3Ch	-49.500	7Ch	-25.500	BCh	-1.500	FCh	17.625
3Dh	-49.125	7Dh	-25.125	BDh	-1.125	FDh	17.625
3Eh	-48.750	7Eh	-24.750	BEh	-0.750	FEh	17.625
3Fh	-48.375	7Fh	-24.375	BFh	-0.375	FFh	17.625

Table 40 AIF1 Output Path Digital Volume Range

AIF1 - OUTPUT PATH HIGH PASS FILTER

A digital high-pass filter can be enabled in the AIF1 output paths to remove DC offsets. This filter is enabled independently in the four AIF1 output channels using the register bits described in Table 41.

The HPF cut-off frequency for the AIF1 Timeslot 0 channels is set using AIF1ADC1_HPF_CUT. The HPF cut-off frequency for the AIF1 Timeslot 1 channels is set using AIF1ADC2_HPF_CUT.

In hi-fi mode, the high pass filter is optimised for removing DC offsets without degrading the bass response and has a cut-off frequency of 3.7Hz when the sample rate (f_s) = 44.1kHz.

In voice modes, the high pass filter is optimised for voice communication; it is recommended to set the cut-off frequency below 300Hz.

Note that the cut-off frequencies scale with the AIF1 sample rate. (The AIF1 sample rate is set using the AIF1_SR register, as described in the “Clocking and Sample Rates” section.) See Table 42 for the HPF cut-off frequencies at all supported sample rates.

REGISTER ADDRESS	BIT	LABEL	DEFAULT	DESCRIPTION
R1040 (0410h) AIF1 ADC1 Filters	14:13	AIF1ADC1_ HPF_CUT [1:0]	00	AIF1ADC1 output path (AIF1, Timeslot 0) Digital HPF cut-off frequency (fc) 00 = Hi-fi mode (fc = 4Hz at f_s = 48kHz) 01 = Voice mode 1 (fc = 64Hz at f_s = 8kHz) 10 = Voice mode 2 (fc = 130Hz at f_s = 8kHz) 11 = Voice mode 3 (fc = 267Hz at f_s = 8kHz)
	12	AIF1ADC1L_ HPF	0	AIF1ADC1 (Left) output path (AIF1, Timeslot 0) Digital HPF Enable 0 = Disabled 1 = Enabled
	11	AIF1ADC1R_ HPF	0	AIF1ADC1 (Right) output path (AIF1, Timeslot 0) Digital HPF Enable 0 = Disabled 1 = Enabled
R1041 (0411h) AIF1 ADC2 Filters	14:13	AIF1ADC2_ HPF_CUT [1:0]	00	AIF1ADC2 output path (AIF1, Timeslot 1) Digital HPF cut-off frequency (fc) 00 = Hi-fi mode (fc = 4Hz at f_s = 48kHz) 01 = Voice mode 1 (fc = 64Hz at f_s = 8kHz) 10 = Voice mode 2 (fc = 130Hz at f_s = 8kHz) 11 = Voice mode 3 (fc = 267Hz at f_s = 8kHz)
	12	AIF1ADC2L_ HPF	0	AIF1ADC2 (Left) output path (AIF1, Timeslot 1) Digital HPF Enable 0 = Disabled 1 = Enabled
	11	AIF1ADC2R_ HPF	0	AIF1ADC2 (Right) output path (AIF1, Timeslot 1) Digital HPF Enable 0 = Disabled 1 = Enabled

Table 41 AIF1 Output Path High Pass Filter

Sample Frequency (kHz)	Cut-Off Frequency (Hz) for given value of AIF n ADC n _HPF_CUT			
	00	01	10	11
8.000	0.7	64	130	267
11.025	0.9	88	178	367
16.000	1.3	127	258	532
22.050	1.9	175	354	733
24.000	2.0	190	386	798
32.000	2.7	253	514	1063
44.100	3.7	348	707	1464
48.000	4.0	379	770	1594
88.200	7.4	696	1414	2928
96.000	8.0	758	1540	3188

Table 42 AIF1 Output Path High Pass Filter Cut-Off Frequencies

AIF1 - INPUT PATH VOLUME CONTROL

The AIF1 interface supports up to four input channels. A digital volume control is provided on each of these input signal paths, allowing attenuation in the range -71.625dB to 0dB in 0.375dB steps. The level of attenuation for an eight-bit code X is given by:

$$0.375 \times (X-192) \text{ dB for } 1 \leq X \leq 192; \quad \text{MUTE for } X = 0 \quad 0\text{dB for } 192 \leq X \leq 255$$

The AIF1DAC1_VU and AIF1DAC2_VU bits control the loading of digital volume control data. When the volume update bit is set to 0, the associated volume control data will be loaded into the respective control register, but will not actually change the digital gain setting.

The AIF1DAC1L and AIF1DAC1R gain settings are updated when a 1 is written to AIF1DAC1_VU. The AIF1DAC2L and AIF1DAC2R gain settings are updated when a 1 is written to AIF1DAC2_VU. This makes it possible to update the gain of left and right channels simultaneously.

Note that a digital gain function is also available at the audio interface input, to boost the DAC volume when a small signal is received on DACDAT1. See "Digital Audio Interface Control" for further details.

Digital volume control is also possible at the DAC stage of the signal path, after the audio signal has passed through the DAC digital mixers. See "Digital to Analogue Converter (DAC)" for further details.

REGISTER ADDRESS	BIT	LABEL	DEFAULT	DESCRIPTION
R1026 (0402h) AIF1 DAC1 Left Volume	8	AIF1DAC1_VU	N/A	AIF1DAC1 input path (AIF1, Timeslot 0) Volume Update Writing a 1 to this bit will cause the AIF1DAC1L and AIF1DAC1R volume to be updated simultaneously
	7:0	AIF1DAC1L_VOL [7:0]	C0h (0dB)	AIF1DAC1 (Left) input path (AIF1, Timeslot 0) Digital Volume 00h = MUTE 01h = -71.625dB ... (0.375dB steps) C0h = 0dB FFh = 0dB (See Table 44 for volume range)
R1027 (0403h) AIF1 DAC1 Right Volume	8	AIF1DAC1_VU	N/A	AIF1DAC1 input path (AIF1, Timeslot 0) Volume Update Writing a 1 to this bit will cause the AIF1DAC1L and AIF1DAC1R volume to be updated simultaneously
	7:0	AIF1DAC1R_VOL [7:0]	C0h (0dB)	AIF1DAC1 (Right) input path (AIF1, Timeslot 0) Digital Volume 00h = MUTE 01h = -71.625dB ... (0.375dB steps) C0h = 0dB FFh = 0dB (See Table 44 for volume range)
R1030 (0406h) AIF1 DAC2 Left Volume	8	AIF1DAC2_VU	N/A	AIF1DAC2 input path (AIF1, Timeslot 1) Volume Update Writing a 1 to this bit will cause the AIF1DAC2L and AIF1DAC2R volume to be updated simultaneously

REGISTER ADDRESS	BIT	LABEL	DEFAULT	DESCRIPTION
	7:0	AIF1DAC2L_VOL [7:0]	C0h (0dB)	AIF1DAC2 (Left) input path (AIF1, Timeslot 1) Digital Volume 00h = MUTE 01h = -71.625dB ... (0.375dB steps) C0h = 0dB FFh = 0dB (See Table 44 for volume range)
R1031 (0407h) AIF1 DAC2 Right Volume	8	AIF1DAC2_VU	N/A	AIF1DAC2 input path (AIF1, Timeslot 1) Volume Update Writing a 1 to this bit will cause the AIF1DAC2L and AIF1DAC2R volume to be updated simultaneously
	7:0	AIF1DAC2R_VOL [7:0]	C0h (0dB)	AIF1DAC2 (Right) input path (AIF1, Timeslot 1) Digital Volume 00h = MUTE 01h = -71.625dB ... (0.375dB steps) C0h = 0dB FFh = 0dB (See Table 44 for volume range)

Table 43 AIF1 Input Path Volume Control

AIF1/AIF2 Input Volume	Volume (dB)	AIF1/AIF2 Input Volume	Volume (dB)	AIF1/AIF2 Input Volume	Volume (dB)	AIF1/AIF2 Input Volume	Volume (dB)
0h	MUTE	40h	-48.000	80h	-24.000	C0h	0.000
1h	-71.625	41h	-47.625	81h	-23.625	C1h	0.000
2h	-71.250	42h	-47.250	82h	-23.250	C2h	0.000
3h	-70.875	43h	-46.875	83h	-22.875	C3h	0.000
4h	-70.500	44h	-46.500	84h	-22.500	C4h	0.000
5h	-70.125	45h	-46.125	85h	-22.125	C5h	0.000
6h	-69.750	46h	-45.750	86h	-21.750	C6h	0.000
7h	-69.375	47h	-45.375	87h	-21.375	C7h	0.000
8h	-69.000	48h	-45.000	88h	-21.000	C8h	0.000
9h	-68.625	49h	-44.625	89h	-20.625	C9h	0.000
Ah	-68.250	4Ah	-44.250	8Ah	-20.250	CAh	0.000
Bh	-67.875	4Bh	-43.875	8Bh	-19.875	CBh	0.000
Ch	-67.500	4Ch	-43.500	8Ch	-19.500	CCh	0.000
Dh	-67.125	4Dh	-43.125	8Dh	-19.125	CDh	0.000
Eh	-66.750	4Eh	-42.750	8Eh	-18.750	CEh	0.000
Fh	-66.375	4Fh	-42.375	8Fh	-18.375	CFh	0.000
10h	-66.000	50h	-42.000	90h	-18.000	D0h	0.000
11h	-65.625	51h	-41.625	91h	-17.625	D1h	0.000
12h	-65.250	52h	-41.250	92h	-17.250	D2h	0.000
13h	-64.875	53h	-40.875	93h	-16.875	D3h	0.000
14h	-64.500	54h	-40.500	94h	-16.500	D4h	0.000
15h	-64.125	55h	-40.125	95h	-16.125	D5h	0.000
16h	-63.750	56h	-39.750	96h	-15.750	D6h	0.000
17h	-63.375	57h	-39.375	97h	-15.375	D7h	0.000
18h	-63.000	58h	-39.000	98h	-15.000	D8h	0.000
19h	-62.625	59h	-38.625	99h	-14.625	D9h	0.000
1Ah	-62.250	5Ah	-38.250	9Ah	-14.250	DAh	0.000
1Bh	-61.875	5Bh	-37.875	9Bh	-13.875	DBh	0.000
1Ch	-61.500	5Ch	-37.500	9Ch	-13.500	DCh	0.000
1Dh	-61.125	5Dh	-37.125	9Dh	-13.125	DDh	0.000
1Eh	-60.750	5Eh	-36.750	9Eh	-12.750	DEh	0.000
1Fh	-60.375	5Fh	-36.375	9Fh	-12.375	DFh	0.000
20h	-60.000	60h	-36.000	A0h	-12.000	E0h	0.000
21h	-59.625	61h	-35.625	A1h	-11.625	E1h	0.000
22h	-59.250	62h	-35.250	A2h	-11.250	E2h	0.000
23h	-58.875	63h	-34.875	A3h	-10.875	E3h	0.000
24h	-58.500	64h	-34.500	A4h	-10.500	E4h	0.000
25h	-58.125	65h	-34.125	A5h	-10.125	E5h	0.000
26h	-57.750	66h	-33.750	A6h	-9.750	E6h	0.000
27h	-57.375	67h	-33.375	A7h	-9.375	E7h	0.000
28h	-57.000	68h	-33.000	A8h	-9.000	E8h	0.000
29h	-56.625	69h	-32.625	A9h	-8.625	E9h	0.000
2Ah	-56.250	6Ah	-32.250	AAh	-8.250	EAh	0.000
2Bh	-55.875	6Bh	-31.875	ABh	-7.875	EBh	0.000
2Ch	-55.500	6Ch	-31.500	ACh	-7.500	ECh	0.000
2Dh	-55.125	6Dh	-31.125	ADh	-7.125	EDh	0.000
2Eh	-54.750	6Eh	-30.750	A Eh	-6.750	EEh	0.000
2Fh	-54.375	6Fh	-30.375	AFh	-6.375	EFh	0.000
30h	-54.000	70h	-30.000	B0h	-6.000	F0h	0.000
31h	-53.625	71h	-29.625	B1h	-5.625	F1h	0.000
32h	-53.250	72h	-29.250	B2h	-5.250	F2h	0.000
33h	-52.875	73h	-28.875	B3h	-4.875	F3h	0.000
34h	-52.500	74h	-28.500	B4h	-4.500	F4h	0.000
35h	-52.125	75h	-28.125	B5h	-4.125	F5h	0.000
36h	-51.750	76h	-27.750	B6h	-3.750	F6h	0.000
37h	-51.375	77h	-27.375	B7h	-3.375	F7h	0.000
38h	-51.000	78h	-27.000	B8h	-3.000	F8h	0.000
39h	-50.625	79h	-26.625	B9h	-2.625	F9h	0.000
3Ah	-50.250	7Ah	-26.250	BAh	-2.250	FAh	0.000
3Bh	-49.875	7Bh	-25.875	BBh	-1.875	FBh	0.000
3Ch	-49.500	7Ch	-25.500	BCh	-1.500	FCh	0.000
3Dh	-49.125	7Dh	-25.125	BDh	-1.125	FDh	0.000
3Eh	-48.750	7Eh	-24.750	BEh	-0.750	FEh	0.000
3Fh	-48.375	7Fh	-24.375	BFh	-0.375	FFh	0.000

Table 44 AIF1 Input Path Digital Volume Range

AIF1 - INPUT PATH SOFT MUTE CONTROL

The WM8958 provides a soft mute function for each of the AIF1 interface input paths. When the soft-mute function is selected, the WM8958 gradually attenuates the associated signal paths until the path is entirely muted.

When the soft-mute function is de-selected, the gain will either return instantly to the digital gain setting, or will gradually ramp back to the digital gain setting, depending on the applicable `_UNMUTE_RAMP` register field.

The mute and un-mute ramp rate is selectable between two different rates.

The AIF1 input paths are soft-muted by default. To play back an audio signal, the soft-mute must first be de-selected by setting the applicable Mute bit to 0.

The soft un-mute would typically be used during playback of audio data so that when the Mute is subsequently disabled, a smooth transition is scheduled to the previous volume level and pop noise is avoided. This is desirable when resuming playback after pausing during a track.

The soft un-mute would typically not be required when un-muting at the start of a music file, in order that the first part of the music track is not attenuated. The instant un-mute behaviour is desirable in this case, when starting playback of a new track. See "DAC Soft Mute and Soft Un-Mute" (Figure 29) for an illustration of the soft mute function.

REGISTER ADDRESS	BIT	LABEL	DEFAULT	DESCRIPTION
R1056 (0420h) AIF1 DAC1 Filters (1)	9	AIF1DAC1_MUTE	1	AIF1DAC1 input path (AIF1, Timeslot 0) Soft Mute Control 0 = Un-mute 1 = Mute
	5	AIF1DAC1_MUTERATE	0	AIF1DAC1 input path (AIF1, Timeslot 0) Soft Mute Ramp Rate 0 = Fast ramp (fs/2, maximum ramp time is 10.7ms at fs=48k) 1 = Slow ramp (fs/32, maximum ramp time is 171ms at fs=48k) (Note: ramp rate scales with sample rate.)
	4	AIF1DAC1_UNMUTE_RAMP	0	AIF1DAC1 input path (AIF1, Timeslot 0) Unmute Ramp select 0 = Disabling soft-mute (AIF1DAC1_MUTE=0) will cause the volume to change immediately to AIF1DAC1L_VOL and AIF1DAC1R_VOL settings 1 = Disabling soft-mute (AIF1DAC1_MUTE=0) will cause the DAC volume to ramp up gradually to the AIF1DAC1L_VOL and AIF1DAC1R_VOL settings
R1058 (0422h) AIF1 DAC2 Filters (1)	9	AIF1DAC2_MUTE	1	AIF1DAC2 input path (AIF1, Timeslot 1) Soft Mute Control 0 = Un-mute 1 = Mute
	5	AIF1DAC2_MUTERATE	0	AIF1DAC2 input path (AIF1, Timeslot 1) Soft Mute Ramp Rate 0 = Fast ramp (fs/2, maximum ramp time is 10.7ms at fs=48k) 1 = Slow ramp (fs/32, maximum ramp time is 171ms at fs=48k) (Note: ramp rate scales with sample rate.)
	4	AIF1DAC2_UNMUTE_RAMP	0	AIF1DAC2 input path (AIF1, Timeslot 1) Unmute Ramp select 0 = Disabling soft-mute (AIF1DAC2_MUTE=0) will cause the volume to change immediately to AIF1DAC2L_VOL and AIF1DAC2R_VOL settings

REGISTER ADDRESS	BIT	LABEL	DEFAULT	DESCRIPTION
				1 = Disabling soft-mute (AIF1DAC2_MUTE=0) will cause the DAC volume to ramp up gradually to the AIF1DAC2L_VOL and AIF1DAC2R_VOL settings

Table 45 AIF1 Input Path Soft Mute Control

AIF1 - INPUT PATH NOISE GATE CONTROL

The WM8958 provides a digital noise gate function for the AIF1 input paths. The noise gate ensures best noise performance when the signal path is idle. When the noise gate is enabled, and the signal level is below the noise gate threshold, then the noise gate is activated, causing the signal path to be muted.

The AIF1 Timeslot 0 input path noise gate is enabled using the AIF1DAC1_NG_ENA register. The AIF1 Timeslot 1 input path noise gate is enabled using the AIF1DAC2_NG_ENA register.

The noise gate threshold (the signal level below which the noise gate is activated) is set using AIF1DAC1_NG_THR or AIF1DAC2_NG_THR.

To prevent erroneous triggering, a time delay is applied before the gate is activated; the signal path is only muted when the signal level stays below the threshold for longer than 'hold time', determined by the AIF1DAC1_NG_HLD or AIF1DAC2_NG_HLD registers.

When the noise gate is activated, the WM8958 gradually attenuates the associated AIF1 input signal paths until each is entirely muted. When the signal level increases, and the noise gate is de-activated, the gain will return to the AIF1DACnL_VOL and AIF1DACnR_VOL digital gain settings (where n = 1 for AIF1 Timeslot 0, and n = 2 for AIF1 Timeslot 1). The un-mute behaviour can be immediate or gradual; this is determined by the AIF1DACn_MUTERATE and AIF1DACn_UNMUTE_RAMP registers described in Table 45.

REGISTER ADDRESS	BIT	LABEL	DEFAULT	DESCRIPTION
R1072 (0430h) AIF1 DAC1 Noise Gate	6:5	AIF1DAC1_NG_HLD [1:0]	11	AIF1DAC1 input path (AIF1, Timeslot 0) Noise Gate Hold Time (delay before noise gate is activated) 00 = 30ms 01 = 125ms 10 = 250ms 11 = 500ms
	3:1	AIF1DAC1_NG_THR [2:0]	100	AIF1DAC1 input path (AIF1, Timeslot 0) Noise Gate Threshold 000 = -60dB 001 = -66dB 010 = -72dB 011 = -78dB 100 = -84dB 101 = -90dB 110 = -96dB 111 = -102dB
	0	AIF1DAC1_NG_ENA	0	AIF1DAC1 input path (AIF1, Timeslot 0) Noise Gate Enable 0 = Disabled 1 = Enabled
R1073 (0431h) AIF1 DAC2 Noise Gate	6:5	AIF1DAC2_NG_HLD [1:0]	11	AIF1DAC2 input path (AIF1, Timeslot 1) Noise Gate Hold Time (delay before noise gate is activated) 00 = 30ms 01 = 125ms 10 = 250ms

REGISTER ADDRESS	BIT	LABEL	DEFAULT	DESCRIPTION
				11 = 500ms
	3:1	AIF1DAC2_ NG_THR [2:0]	100	AIF1DAC2 input path (AIF1, Timeslot 1) Noise Gate Threshold 000 = -60dB 001 = -66dB 010 = -72dB 011 = -78dB 100 = -84dB 101 = -90dB 110 = -96dB 111 = -102dB
	0	AIF1DAC2_ NG_ENA	0	AIF1DAC2 input path (AIF1, Timeslot 1) Noise Gate Enable 0 = Disabled 1 = Enabled

Table 46 AIF1 Input Path Noise Gate Control

AIF1 - INPUT PATH MONO MIX CONTROL

A digital mono mix can be selected on one or both pairs of AIF1 input channels. The mono mix is generated as the sum of the Left and Right AIF channel data. When the mono mix function is enabled, the combined mono signal is applied to the Left channel and the Right channel of the respective AIF1 signal processing and digital mixing paths. To prevent clipping, 6dB attenuation is applied to the mono mix.

REGISTER ADDRESS	BIT	LABEL	DEFAULT	DESCRIPTION
R1056 (0420h) AIF1 DAC1 Filters (1)	7	AIF1DAC1_ MONO	0	AIF1DAC1 input path (AIF1, Timeslot 0) Mono Mix Control 0 = Disabled 1 = Enabled
R1058 (0422h) AIF1 DAC2 Filters (1)	7	AIF1DAC2_ MONO	0	AIF1DAC2 input path (AIF1, Timeslot 1) Mono Mix Control 0 = Disabled 1 = Enabled

Table 47 AIF1 Input Path Mono Mix Control

AIF2 - OUTPUT PATH VOLUME CONTROL

The AIF2 interface supports two output channels. A digital volume control is provided on each output signal path, allowing attenuation in the range -71.625dB to +17.625dB in 0.375dB steps. The level of attenuation for an eight-bit code X is given by:

$$0.375 \times (X-192) \text{ dB for } 1 \leq X \leq 239; \quad \text{MUTE for } X = 0 \quad +17.625\text{dB for } 239 \leq X \leq 255$$

The AIF2ADC_VU bit controls the loading of digital volume control data. When AIF2ADC_VU bit is set to 0, the AIF2ADCL_VOL and AIF2ADCR_VOL control data will be loaded into the respective control register, but will not actually change the digital gain setting. Both left and right gain settings are updated when a 1 is written to AIF2ADC_VU. This makes it possible to update the gain of left and right channels simultaneously.

REGISTER ADDRESS	BIT	LABEL	DEFAULT	DESCRIPTION
R1280 (0500h) AIF2 ADC Left Volume	8	AIF2ADC_V U	N/A	AIF2ADC output path Volume Update Writing a 1 to this bit will cause the AIF2ADCL and AIF2ADCR volume to be updated simultaneously
	7:0	AIF2ADCL_ VOL [7:0]	C0h (0dB)	AIF2ADC (Left) output path Digital Volume 00h = MUTE 01h = -71.625dB ... (0.375dB steps) EFh = +17.625dB (See Table 40 for volume range)
R1281 (0501h) AIF2 ADC Right Volume	8	AIF2ADC_V U	N/A	AIF2ADC output path Volume Update Writing a 1 to this bit will cause the AIF2ADCL and AIF2ADCR volume to be updated simultaneously
	7:0	AIF2ADCR_ VOL [7:0]	C0h (0dB)	AIF2ADC (Right) output path Digital Volume 00h = MUTE 01h = -71.625dB ... (0.375dB steps) EFh = +17.625dB (See Table 40 for volume range)

Table 48 AIF2 Output Path Volume Control

AIF2 - OUTPUT PATH HIGH PASS FILTER

A digital high-pass filter can be enabled in the AIF2 output paths to remove DC offsets. This filter is enabled independently in the two AIF2 output channels using the register bits described in Table 49.

The HPF cut-off frequency for the AIF2 channels is set using AIF2ADC_HPF_CUT.

In hi-fi mode, the high pass filter is optimised for removing DC offsets without degrading the bass response and has a cut-off frequency of 3.7Hz when the sample rate (f_s) = 44.1kHz.

In voice modes, the high pass filter is optimised for voice communication; it is recommended to set the cut-off frequency below 300Hz.

Note that the cut-off frequencies scale with the AIF2 sample rate. (The AIF2 sample rate is set using the AIF2_SR register, as described in the "Clocking and Sample Rates" section.) See Table 42 for the HPF cut-off frequencies at all supported sample rates.

REGISTER ADDRESS	BIT	LABEL	DEFAULT	DESCRIPTION
R1296 (0510h) AIF2 ADC Filters	14:13	AIF2ADC_H PF_CUT [1:0]	00	AIF2ADC output path Digital HPF Cut-Off Frequency (f_c) 00 = Hi-fi mode (f_c = 4Hz at f_s = 48kHz) 01 = Voice mode 1 (f_c = 127Hz at f_s = 8kHz) 10 = Voice mode 2 (f_c = 130Hz at f_s = 8kHz) 11 = Voice mode 3 (f_c = 267Hz at f_s = 8kHz)
	12	AIF2ADCL_ HPF	0	AIF2ADC (Left) output path Digital HPF Enable 0 = Disabled 1 = Enabled
	11	AIF2ADCR_ HPF	0	AIF2ADC (Right) output path Digital HPF Enable 0 = Disabled 1 = Enabled

Table 49 AIF2 Output Path High Pass Filter

AIF2 - INPUT PATH VOLUME CONTROL

The AIF2 interface supports two input channels. A digital volume control is provided on each input signal path, allowing attenuation in the range -71.625dB to 0dB in 0.375dB steps. The level of attenuation for an eight-bit code X is given by:

$$0.375 \times (X-192) \text{ dB for } 1 \leq X \leq 192; \quad \text{MUTE for } X = 0 \quad 0\text{dB for } 192 \leq X \leq 255$$

The AIF2DAC_VU bit controls the loading of digital volume control data. When AIF2DAC_VU bit is set to 0, the AIF2DACL_VOL and AIF2DACR_VOL control data will be loaded into the respective control register, but will not actually change the digital gain setting. Both left and right gain settings are updated when a 1 is written to AIF2DAC_VU. This makes it possible to update the gain of left and right channels simultaneously.

Note that a digital gain function is also available at the audio interface input, to boost the DAC volume when a small signal is received on DACDAT2. See "Digital Audio Interface Control" for further details.

Digital volume control is also possible at the DAC stage of the signal path, after the audio signal has passed through the DAC digital mixers. See "Digital to Analogue Converter (DAC)" for further details.

REGISTER ADDRESS	BIT	LABEL	DEFAULT	DESCRIPTION
R1282 (0502h) AIF2 DAC Left Volume	8	AIF2DAC_VU	N/A	AIF2DAC input path Volume Update Writing a 1 to this bit will cause the AIF2DACL and AIF2DACR volume to be updated simultaneously
	7:0	AIF2DACL_VOL [7:0]	C0h (0dB)	AIF2DAC (Left) input path Digital Volume 00h = MUTE 01h = -71.625dB ... (0.375dB steps) C0h = 0dB FFh = 0dB (See Table 44 for volume range)
R1283 (0503h) AIF2 DAC Right Volume	8	AIF2DAC_VU	N/A	AIF2DAC input path Volume Update Writing a 1 to this bit will cause the AIF2DACL and AIF2DACR volume to be updated simultaneously
	7:0	AIF2DACR_VOL [7:0]	C0h (0dB)	AIF2DAC (Right) input path Digital Volume 00h = MUTE 01h = -71.625dB ... (0.375dB steps) C0h = 0dB FFh = 0dB (See Table 44 for volume range)

Table 50 AIF2 Input Path Volume Control

AIF2 - INPUT PATH SOFT MUTE CONTROL

The WM8958 provides a soft mute function for each of the AIF2 interface input paths. When the soft-mute function is selected, the WM8958 gradually attenuates the associated signal paths until the path is entirely muted.

When the soft-mute function is de-selected, the gain will either return instantly to the digital gain setting, or will gradually ramp back to the digital gain setting, depending on the AIF2DAC_UNMUTE_RAMP register field.

The mute and un-mute ramp rate is selectable between two different rates.

The AIF2 input paths are soft-muted by default. To play back an audio signal, the soft-mute must first be de-selected by setting AIF2DAC_MUTE = 0.

The soft un-mute would typically be used during playback of audio data so that when the Mute is subsequently disabled, a smooth transition is scheduled to the previous volume level and pop noise is avoided. This is desirable when resuming playback after pausing during a track.

The soft un-mute would typically not be required when un-muting at the start of a music file, in order that the first part of the music track is not attenuated. The instant un-mute behaviour is desirable in this case, when starting playback of a new track. See "DAC Soft Mute and Soft Un-Mute" (Figure 29) for an illustration of the soft mute function.

REGISTER ADDRESS	BIT	LABEL	DEFAULT	DESCRIPTION
R1312 (0520h) AIF2 DAC Filters (1)	9	AIF2DAC_MUTE	1	AIF2DAC input path Soft Mute Control 0 = Un-mute 1 = Mute
	5	AIF2DAC_MUTERATE	0	AIF2DAC input path Soft Mute Ramp Rate 0 = Fast ramp (fs/2, maximum ramp time is 10.7ms at fs=48k) 1 = Slow ramp (fs/32, maximum ramp time is 171ms at fs=48k) (Note: ramp rate scales with sample rate.)
	4	AIF2DAC_UNMUTE_RAMP	0	AIF2DAC input path Unmute Ramp select 0 = Disabling soft-mute (AIF2DAC_MUTE=0) will cause the volume to change immediately to AIF2DACL_VOL and AIF2DACR_VOL settings 1 = Disabling soft-mute (AIF2DAC_MUTE=0) will cause the DAC volume to ramp up gradually to the AIF2DACL_VOL and AIF2DACR_VOL settings

Table 51 AIF2 Input Path Soft Mute Control

AIF2 - INPUT PATH NOISE GATE CONTROL

The WM8958 provides a digital noise gate function for the AIF2 input paths. The noise gate ensures best noise performance when the signal path is idle. When the noise gate is enabled, and the signal level is below the noise gate threshold, then the noise gate is activated, causing the signal path to be muted.

The AIF2 input path noise gate is enabled using the AIF2DAC_NG_ENA register.

The noise gate threshold (the signal level below which the noise gate is activated) is set using AIF2DAC_NG_THR.

To prevent erroneous triggering, a time delay is applied before the gate is activated; the signal path is only muted when the signal level stays below the threshold for longer than 'hold time', determined by the AIF2DAC_NG_HLD register.

When the noise gate is activated, the WM8958 gradually attenuates the AIF2 input signal paths until each is entirely muted. When the signal level increases, and the noise gate is de-activated, the gain will return to the AIF2DACL_VOL and AIF2DACR_VOL digital gain settings. The un-mute behaviour

can be immediate or gradual; this is determined by the AIF2DAC_MUTERATE and AIF2DAC_UNMUTE_RAMP registers described in Table 51.

REGISTER ADDRESS	BIT	LABEL	DEFAULT	DESCRIPTION
R1328 (0530h) AIF2 DAC Noise Gate	6:5	AIF2DAC_ NG_HLD [1:0]	11	AIF2DAC input path Noise Gate Hold Time (delay before noise gate is activated) 00 = 30ms 01 = 125ms 10 = 250ms 11 = 500ms
	3:1	AIF2DAC_ NG_THR [2:0]	100	AIF2DAC input path Noise Gate Threshold 000 = -60dB 001 = -66dB 010 = -72dB 011 = -78dB 100 = -84dB 101 = -90dB 110 = -96dB 111 = -102dB
	0	AIF2DAC_ NG_ENA	0	AIF2DAC input path Noise Gate Enable 0 = Disabled 1 = Enabled

Table 52 AIF2 Input Path Noise Gate Control

AIF2 - INPUT PATH MONO MIX CONTROL

A digital mono mix can be selected on the AIF2 input channels. The mono mix is generated as the sum of the Left and Right AIF channel data. When the mono mix function is enabled, the combined mono signal is applied to the Left channel and the Right channel of the AIF2 signal processing and digital mixing paths. To prevent clipping, 6dB attenuation is applied to the mono mix.

REGISTER ADDRESS	BIT	LABEL	DEFAULT	DESCRIPTION
R1312 (0520h) AIF2 DAC Filters (1)	7	AIF2DAC_M ONO	0	AIF2DAC input path Mono Mix Control 0 = Disabled 1 = Enabled

Table 53 AIF2 Input Path Mono Mix Control

DIGITAL TO ANALOGUE CONVERTER (DAC)

The WM8958 DACs receive digital input data from the DAC mixers - see "Digital Mixing". The digital audio data is converted to oversampled bit streams in the on-chip, true 24-bit digital interpolation filters. The bitstream data enters four multi-bit, sigma-delta DACs, which convert them to high quality analogue audio signals. The multi-bit DAC architecture reduces high frequency noise and sensitivity to clock jitter. It also uses a Dynamic Element Matching technique for high linearity and low distortion.

A high performance mode of DAC operation can be selected by setting the DAC_OSR128 bit - see "Clocking and Sample Rates" for details.

The analogue outputs from the DACs can be mixed with analogue line/mic inputs using the line output mixers MIXOUTL / MIXOUTR and the speaker output mixers SPKMIXL / SPKMIXR.

The DACs are enabled using the register bits defined in Table 54.

Note that the DAC clock must be enabled whenever the DACs are enabled.

REGISTER ADDRESS	BIT	LABEL	DEFAULT	DESCRIPTION
R5 (0005h) Power Management (5)	3	DAC2L_EN A	0	Left DAC2 Enable 0 = Disabled 1 = Enabled
	2	DAC2R_EN A	0	Right DAC2 Enable 0 = Disabled 1 = Enabled
	1	DAC1L_EN A	0	Left DAC1 Enable 0 = Disabled 1 = Enabled
	0	DAC1R_EN A	0	Right DAC1 Enable 0 = Disabled 1 = Enabled

Table 54 DAC Enable Control

DAC CLOCKING CONTROL

Clocking for the DACs is derived from SYSCLK. The required clock is enabled when the SYDSPCLK_ENA register is set.

The DAC clock rate is configured automatically, according to the AIFn_SR, AIFnCLK_RATE and DAC_OSR128 registers. (See "Clocking and Sample Rates" for further details of the system clocks and control registers.)

When AIF1CLK is selected as the SYSCLK source (SYSCLK_SRC = 0), then the DAC clocking is controlled by the AIF1_SR and AIF1CLK_RATE registers.

When AIF2CLK is selected as the SYSCLK source (SYSCLK_SRC = 1), then the DAC clocking is controlled by the AIF2_SR and AIF2CLK_RATE registers.

The supported DAC clocking configurations are described in Table 55 (for DAC_OSR128=0) and Table 56 (for DAC_OSR128=1). Under default conditions, the DAC_OSR128 bit is not set.

SAMPLE RATE (kHz)	SYSCLK RATE (AIFnCLK / fs ratio)							
	128	192	256	384	512	768	1024	1536
8			✓	✓	✓	✓	✓	✓
11.025		Note 1	✓	✓	✓	✓	✓	
12		Note 1	✓	✓	✓	✓	✓	
16	Note 1	Note 1	✓	✓	✓	✓		
22.05	Note 1	Note 1	✓	✓	✓			
24	Note 1	Note 1	✓	✓	✓			
32	Note 1	Note 1	✓	✓				
44.1	Note 1	Note 1	✓					
48	Note 1	Note 1	✓					
88.2	Note 1							
96	Note 1							

When DAC_OSR128=0, DAC operation is only supported for the configurations indicated above

Table 55 DAC Clocking - DAC_OSR128 = 0 (Default)

SAMPLE RATE (kHz)	SYSCLK RATE (AIFnCLK / fs ratio)							
	128	192	256	384	512	768	1024	1536
8					✓	✓	✓	✓
11.025				✓	✓	✓	✓	
12				✓	✓	✓	✓	
16			✓	✓	✓	✓		
22.05		Note 1	✓	✓	✓			
24		Note 1	✓	✓	✓			
32	Note 1	Note 1	✓	✓				
44.1	Note 1	Note 1	✓					
48	Note 1	Note 1	✓					
88.2	Note 1							
96	Note 1							

When DAC_OSR128=1, DAC operation is only supported for the configurations indicated above

Table 56 DAC Clocking - DAC_OSR128 = 1

Note 1 - These clocking rates are only supported for 'simple' DAC-only playback modes, under the following conditions:

- AIF input is enabled on a single interface (AIF1 or AIF2) only, or is enabled on AIF1 and AIF2 simultaneously provided AIF1 and AIF2 are synchronised (ie. AIF1CLK_SRC = AIF2CLK_SRC)
- All AIF output paths are disabled
- All DSP functions (ReTune™ Mobile Parametric Equaliser, 3D stereo expansion and Dynamic Range Control) are disabled

The clocking requirements in Table 55 and Table 56 are only applicable to the AIFnCLK that is selected as the SYSCLK source. Note that both clocks (AIF1CLK and AIF2CLK) must satisfy the requirements noted in the "Clocking and Sample Rates" section.

The applicable clocks (SYSCLK, and AIF1CLK or AIF2CLK) must be present and enabled when using the Digital to Analogue Converters (DACs).

Note that the presence of a suitable clock is automatically detected by the WM8958; if the clock signal is absent, then any speaker or earpiece output driver(s) associated with the DAC signal paths will be disabled. (This is applicable to the SPKOUTL, SPKOUTR and HPOUT2 outputs only, whenever one or more DAC is routed to these output drivers.)

DAC DIGITAL VOLUME

The output level of each DAC can be controlled digitally over a range from -71.625dB to +12dB in 0.375dB steps. The level of attenuation for an eight-bit code X is given by:

$$0.375 \times (X-192) \text{ dB for } 1 \leq X \leq 224; \quad \text{MUTE for } X = 0; \quad 12\text{dB to } 224 \leq X \leq 255$$

Each of the DACs can be muted using the soft mute control bits described in Table 57. The WM8958 always applies a soft mute, where the volume is decreased gradually. The un-mute behaviour is configurable, as described in the “DAC Soft Mute and Soft Un-Mute” section.

The DAC1_VU and DAC2_VU bits control the loading of digital volume control data. When DAC1_VU is set to 0, the DAC1L_VOL or DAC1R_VOL control data will be loaded into the respective control register, but will not actually change the digital gain setting. Both left and right gain settings are updated when a 1 is written to DAC1_VU. This makes it possible to update the gain of both channels simultaneously. A similar function for DAC2L and DAC2R is controlled by the DAC2_VU register bit.

REGISTER ADDRESS	BIT	LABEL	DEFAULT	DESCRIPTION
R1552 (0610h) DAC1 Left Volume	9	DAC1L_MUTE	1	DAC1L Soft Mute Control 0 = DAC Un-mute 1 = DAC Mute
	8	DAC1_VU	N/A	DAC1L and DAC1R Volume Update Writing a 1 to this bit will cause the DAC1L and DAC1R volume to be updated simultaneously
	7:0	DAC1L_VOL [7:0]	C0h (0dB)	DAC1L Digital Volume 00h = MUTE 01h = -71.625dB ... (0.375dB steps) C0h = 0dB ... (0.375dB steps) E0h = 12dB FFh = 12dB (See Table 58 for volume range)
R1553 (0611h) DAC1 Right Volume	9	DAC1R_MUTE	1	DAC1R Soft Mute Control 0 = DAC Un-mute 1 = DAC Mute
	8	DAC1_VU	N/A	DAC1L and DAC1R Volume Update Writing a 1 to this bit will cause the DAC1L and DAC1R volume to be updated simultaneously
	7:0	DAC1R_VOL [7:0]	C0h (0dB)	DAC1R Digital Volume 00h = MUTE 01h = -71.625dB ... (0.375dB steps) C0h = 0dB ... (0.375dB steps) E0h = 12dB FFh = 12dB (See Table 58 for volume range)
R1554 (0612h) DAC2 Left Volume	9	DAC2L_MUTE	1	DAC2L Soft Mute Control 0 = DAC Un-mute 1 = DAC Mute
	8	DAC2_VU	N/A	DAC2L and DAC2R Volume Update Writing a 1 to this bit will cause the DAC2L and DAC2R volume to be updated simultaneously

REGISTER ADDRESS	BIT	LABEL	DEFAULT	DESCRIPTION
	7:0	DAC2L_VO L [7:0]	C0h (0dB)	DAC2L Digital Volume 00h = MUTE 01h = -71.625dB ... (0.375dB steps) C0h = 0dB ... (0.375dB steps) E0h = 12dB FFh = 12dB (See Table 58 for volume range)
R1555 (0613h) DAC2 Right Volume	9	DAC2R_MU TE	1	DAC2R Soft Mute Control 0 = DAC Un-mute 1 = DAC Mute
	8	DAC2_VU	N/A	DAC2R and DAC2R Volume Update Writing a 1 to this bit will cause the DAC2R and DAC2R volume to be updated simultaneously
	7:0	DAC2R_VO L [7:0]	C0h (0dB)	DAC2R Digital Volume 00h = MUTE 01h = -71.625dB ... (0.375dB steps) C0h = 0dB ... (0.375dB steps) E0h = 12dB FFh = 12dB (See Table 58 for volume range)

Table 57 DAC Digital Volume Control

DAC Volume	Volume (dB)	DAC Volume	Volume (dB)	DAC Volume	Volume (dB)	DAC Volume	Volume (dB)
0h	MUTE	40h	-48.000	80h	-24.000	C0h	0.000
1h	-71.625	41h	-47.625	81h	-23.625	C1h	0.375
2h	-71.250	42h	-47.250	82h	-23.250	C2h	0.750
3h	-70.875	43h	-46.875	83h	-22.875	C3h	1.125
4h	-70.500	44h	-46.500	84h	-22.500	C4h	1.500
5h	-70.125	45h	-46.125	85h	-22.125	C5h	1.875
6h	-69.750	46h	-45.750	86h	-21.750	C6h	2.250
7h	-69.375	47h	-45.375	87h	-21.375	C7h	2.625
8h	-69.000	48h	-45.000	88h	-21.000	C8h	3.000
9h	-68.625	49h	-44.625	89h	-20.625	C9h	3.375
Ah	-68.250	4Ah	-44.250	8Ah	-20.250	CAh	3.750
Bh	-67.875	4Bh	-43.875	8Bh	-19.875	CBh	4.125
Ch	-67.500	4Ch	-43.500	8Ch	-19.500	CCh	4.500
Dh	-67.125	4Dh	-43.125	8Dh	-19.125	CDh	4.875
Eh	-66.750	4Eh	-42.750	8Eh	-18.750	CEh	5.250
Fh	-66.375	4Fh	-42.375	8Fh	-18.375	CFh	5.625
10h	-66.000	50h	-42.000	90h	-18.000	D0h	6.000
11h	-65.625	51h	-41.625	91h	-17.625	D1h	6.375
12h	-65.250	52h	-41.250	92h	-17.250	D2h	6.750
13h	-64.875	53h	-40.875	93h	-16.875	D3h	7.125
14h	-64.500	54h	-40.500	94h	-16.500	D4h	7.500
15h	-64.125	55h	-40.125	95h	-16.125	D5h	7.875
16h	-63.750	56h	-39.750	96h	-15.750	D6h	8.250
17h	-63.375	57h	-39.375	97h	-15.375	D7h	8.625
18h	-63.000	58h	-39.000	98h	-15.000	D8h	9.000
19h	-62.625	59h	-38.625	99h	-14.625	D9h	9.375
1Ah	-62.250	5Ah	-38.250	9Ah	-14.250	DAh	9.750
1Bh	-61.875	5Bh	-37.875	9Bh	-13.875	DBh	10.125
1Ch	-61.500	5Ch	-37.500	9Ch	-13.500	DCh	10.500
1Dh	-61.125	5Dh	-37.125	9Dh	-13.125	DDh	10.875
1Eh	-60.750	5Eh	-36.750	9Eh	-12.750	DEh	11.250
1Fh	-60.375	5Fh	-36.375	9Fh	-12.375	DFh	11.625
20h	-60.000	60h	-36.000	A0h	-12.000	E0h	12.000
21h	-59.625	61h	-35.625	A1h	-11.625	E1h	12.000
22h	-59.250	62h	-35.250	A2h	-11.250	E2h	12.000
23h	-58.875	63h	-34.875	A3h	-10.875	E3h	12.000
24h	-58.500	64h	-34.500	A4h	-10.500	E4h	12.000
25h	-58.125	65h	-34.125	A5h	-10.125	E5h	12.000
26h	-57.750	66h	-33.750	A6h	-9.750	E6h	12.000
27h	-57.375	67h	-33.375	A7h	-9.375	E7h	12.000
28h	-57.000	68h	-33.000	A8h	-9.000	E8h	12.000
29h	-56.625	69h	-32.625	A9h	-8.625	E9h	12.000
2Ah	-56.250	6Ah	-32.250	AAh	-8.250	EAh	12.000
2Bh	-55.875	6Bh	-31.875	ABh	-7.875	EBh	12.000
2Ch	-55.500	6Ch	-31.500	ACH	-7.500	ECh	12.000
2Dh	-55.125	6Dh	-31.125	ADh	-7.125	EDh	12.000
2Eh	-54.750	6Eh	-30.750	A Eh	-6.750	EEh	12.000
2Fh	-54.375	6Fh	-30.375	AFh	-6.375	EFh	12.000
30h	-54.000	70h	-30.000	B0h	-6.000	F0h	12.000
31h	-53.625	71h	-29.625	B1h	-5.625	F1h	12.000
32h	-53.250	72h	-29.250	B2h	-5.250	F2h	12.000
33h	-52.875	73h	-28.875	B3h	-4.875	F3h	12.000
34h	-52.500	74h	-28.500	B4h	-4.500	F4h	12.000
35h	-52.125	75h	-28.125	B5h	-4.125	F5h	12.000
36h	-51.750	76h	-27.750	B6h	-3.750	F6h	12.000
37h	-51.375	77h	-27.375	B7h	-3.375	F7h	12.000
38h	-51.000	78h	-27.000	B8h	-3.000	F8h	12.000
39h	-50.625	79h	-26.625	B9h	-2.625	F9h	12.000
3Ah	-50.250	7Ah	-26.250	BAh	-2.250	FAh	12.000
3Bh	-49.875	7Bh	-25.875	BBh	-1.875	FBh	12.000
3Ch	-49.500	7Ch	-25.500	BCh	-1.500	FCh	12.000
3Dh	-49.125	7Dh	-25.125	BDh	-1.125	FDh	12.000
3Eh	-48.750	7Eh	-24.750	BEh	-0.750	FEh	12.000
3Fh	-48.375	7Fh	-24.375	BFh	-0.375	FFh	12.000

Table 58 DAC Digital Volume Range

DAC SOFT MUTE AND SOFT UN-MUTE

The WM8958 has a soft mute function which ensures that a gradual attenuation is applied to the DAC outputs when the mute is asserted. The soft mute rate can be selected using the DAC_MUTERATE bit.

When a mute bit is disabled, the gain will either gradually ramp back up to the digital gain setting, or return instantly to the digital gain setting, depending on the DAC_SOFTMUTEMODE register bit. If the gradual un-mute ramp is selected (DAC_SOFTMUTEMODE = 1), then the un-mute rate is determined by the DAC_MUTERATE bit.

Note that each DAC is soft-muted by default. To play back an audio signal, the mute must first be disabled by setting the applicable mute control to 0 (see Table 57).

Soft Mute Mode would typically be enabled (DAC_SOFTMUTEMODE = 1) when using mute during playback of audio data so that when the mute is subsequently disabled, the volume increase will not create pop noise by jumping immediately to the previous volume level (e.g. resuming playback after pausing during a track).

Soft Mute Mode would typically be disabled (DAC_SOFTMUTEMODE = 0) when un-muting at the start of a music file, in order that the first part of the track is not attenuated (e.g. when starting playback of a new track, or resuming playback after pausing between tracks).

The DAC soft-mute function is illustrated in Figure 29 for DAC1L and DAC1R. The same function is applicable to DAC2L and DAC2R also.

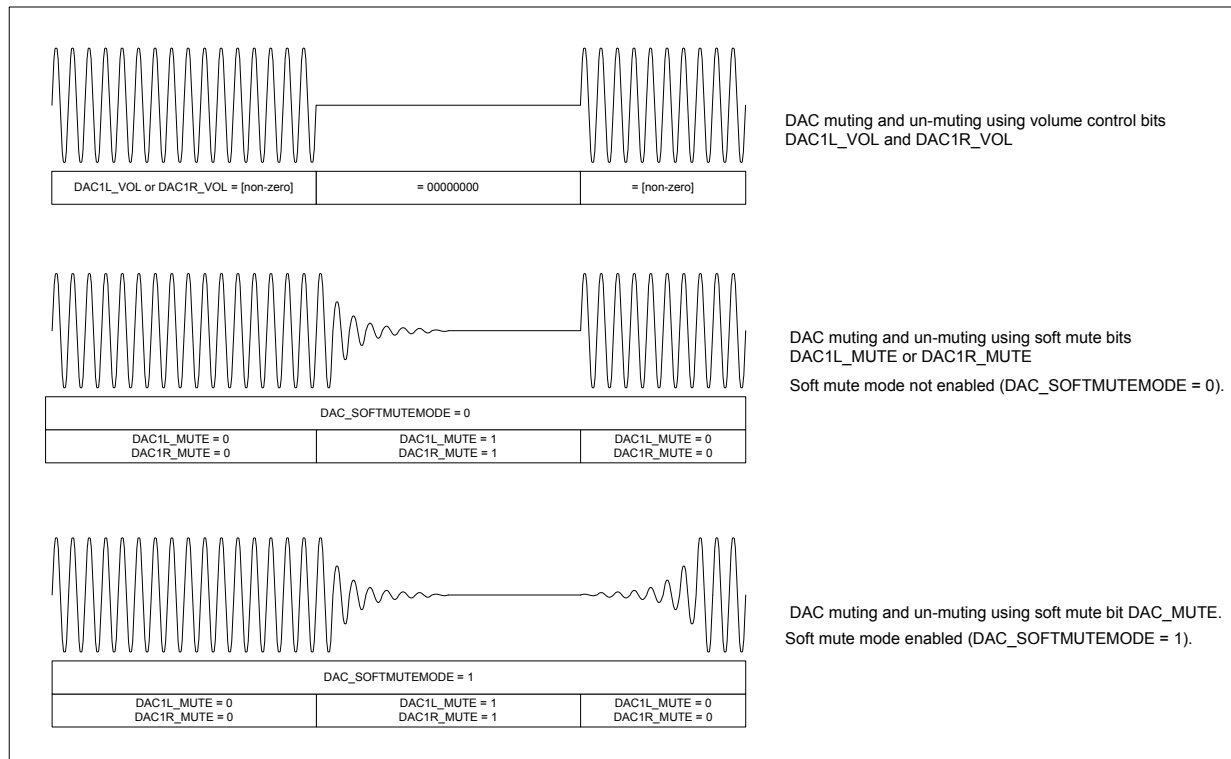

Figure 29 DAC Soft Mute Control

The DAC Soft Mute register controls are defined in Table 59.

The volume ramp rate during soft mute and un-mute is controlled by the DAC_MUTERATE bit. Ramp rates of $fs/32$ and $fs/2$ are selectable. The ramp rate determines the rate at which the volume will be increased or decreased. Note that the actual ramp time depends on the extent of the difference between the muted and un-muted volume settings.

REGISTER ADDRESS	BIT	LABEL	DEFAULT	DESCRIPTION
R1556 (0614h) DAC Softmute	1	DAC_SOFT MUTEMODE	0	DAC Unmute Ramp select 0 = Disabling soft-mute (DAC[1/2][L/R]_MUTE=0) will cause the DAC volume to change immediately to DAC[1/2][L/R]_VOL settings 1 = Disabling soft-mute (DAC[1/2][L/R]_MUTE=0) will cause the DAC volume to ramp up gradually to the DAC[1/2][L/R]_VOL settings
	0	DAC_MUTE RATE	0	DAC Soft Mute Ramp Rate 0 = Fast ramp ($fs/2$, maximum ramp time is 10.7ms at $fs=48k$) 1 = Slow ramp ($fs/32$, maximum ramp time is 171ms at $fs=48k$) (Note: ramp rate scales with sample rate.)

Table 59 DAC Soft-Mute Control

ANALOGUE OUTPUT SIGNAL PATH

The WM8958 output routing and mixers provide a high degree of flexibility, allowing operation of many simultaneous signal paths through the device to a variety of analogue outputs. The outputs include a ground referenced headphone driver, two switchable Class D/AB loudspeaker drivers, an ear speaker driver and four highly flexible line drivers. See “Analogue Outputs” for further details of these outputs.

The WM8958 output signal paths and control registers are illustrated in Figure 30.

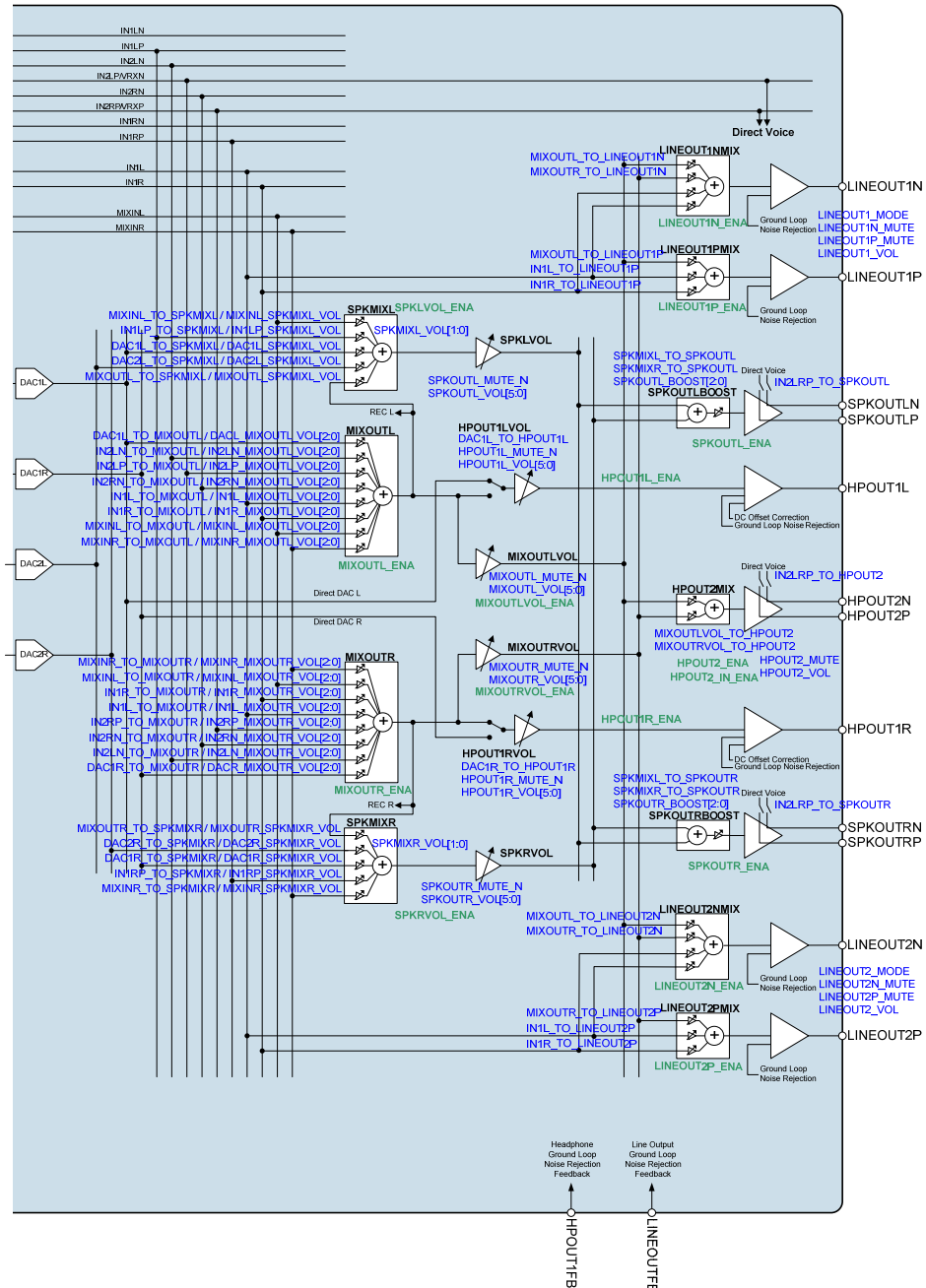

Figure 30 Control Registers for Output Signal Path

OUTPUT SIGNAL PATHS ENABLE

The output mixers and drivers can be independently enabled and disabled as described in Table 60.

The supply rails for headphone outputs HPOUT1L and HPOUT1R are generated using an integrated dual-mode Charge Pump, which must be enabled whenever the headphone outputs are used. See the “Charge Pump” section for details on enabling and configuring this circuit.

Note that the headphone outputs HPOUT1L and HPOUT1R have dedicated output PGAs and volume controls. As a result, a low power consumption DAC playback path can be supported without needing to enable the output mixers MIXOUTL / MIXOUTR or the mixer output PGAs MIXOUTLVOL / MIXOUTRVOL.

Note that the Headphone Outputs are also controlled by fields located within Register R96, which provide suppression of pops & clicks when enabling and disabling the HPOUT1L and HPOUT1R signal paths. These registers are described in the following “Headphone Signal Paths Enable” section.

Under recommended usage conditions, the Headphone Pop Suppression control bits will be configured by scheduling the default Start-Up and Shutdown sequences as described in the “Control Write Sequencer” section. In these cases, the user does not need to set the register fields in R1 and R96 directly.

For normal operation of the output signal paths, the reference voltage VMID and the bias current must also be enabled. See “Reference Voltages and Master Bias” for details of the associated controls VMID_SEL and BIAS_ENA.

REGISTER ADDRESS	BIT	LABEL	DEFAULT	DESCRIPTION
R1 (0001h) Power Management (1)	13	SPKOUTR_ENA	0	SPKMIXR Mixer, SPKRVOL PGA and SPKOUTR Output Enable 0 = Disabled 1 = Enabled
	12	SPKOUTL_ENA	0	SPKMIXL Mixer, SPKLVOL PGA and SPKOUTL Output Enable 0 = Disabled 1 = Enabled
	11	HPOUT2_ENA	0	HPOUT2 Output Stage Enable 0 = Disabled 1 = Enabled
	9	HPOUT1L_ENA	0	Enables HPOUT1L input stage 0 = Disabled 1 = Enabled For normal operation, this bit should be set as the first step of the HPOUT1L Enable sequence.
	8	HPOUT1R_ENA	0	Enables HPOUT1R input stage 0 = Disabled 1 = Enabled For normal operation, this bit should be set as the first step of the HPOUT1R Enable sequence.
R3 (0003h) Power Management (3)	13	LINEOUT1N_ENA	0	LINEOUT1N Line Out and LINEOUT1NMIX Enable 0 = Disabled 1 = Enabled
	12	LINEOUT1P_ENA	0	LINEOUT1P Line Out and LINEOUT1PMIX Enable 0 = Disabled 1 = Enabled
	11	LINEOUT2N_ENA	0	LINEOUT2N Line Out and LINEOUT2NMIX Enable 0 = Disabled 1 = Enabled

REGISTER ADDRESS	BIT	LABEL	DEFAULT	DESCRIPTION
	10	LINEOUT2P_ENA	0	LINEOUT2P Line Out and LINEOUT2PMIX Enable 0 = Disabled 1 = Enabled
	9	SPKRVOL_ENA	0	SPKMIXR Mixer and SPKRVOL PGA Enable 0 = Disabled 1 = Enabled Note that SPKMIXR and SPKRVOL are also enabled when SPKOUTR_ENA is set.
	8	SPKLVOL_ENA	0	SPKMIXL Mixer and SPKLVOL PGA Enable 0 = Disabled 1 = Enabled Note that SPKMIXL and SPKLVOL are also enabled when SPKOUTL_ENA is set.
	7	MIXOUTLVOL_ENA	0	MIXOUTL Left Volume Control Enable 0 = Disabled 1 = Enabled
	6	MIXOUTRVOL_ENA	0	MIXOUTR Right Volume Control Enable 0 = Disabled 1 = Enabled
	5	MIXOUTL_ENA	0	MIXOUTL Left Output Mixer Enable 0 = Disabled 1 = Enabled
	4	MIXOUTR_ENA	0	MIXOUTR Right Output Mixer Enable 0 = Disabled 1 = Enabled
R56 (0038h) AntiPOP (1)	6	HPOUT2_IN_ENA	0	HPOUT2MIX Mixer and Input Stage Enable 0 = Disabled 1 = Enabled

Table 60 Output Signal Paths Enable

HEADPHONE SIGNAL PATHS ENABLE

The HPOUT1L and HPOUT1R output paths can be actively discharged to AGND through internal resistors if desired. This is desirable at start-up in order to achieve a known output stage condition prior to enabling the VMID reference voltage. This is also desirable in shutdown to prevent the external connections from being affected by the internal circuits. The HPOUT1L and HPOUT1R outputs are shorted to AGND by default; the short circuit is removed on each of these paths by setting the applicable fields HPOUT1L_RMV_SHORT or HPOUT1R_RMV_SHORT.

The ground-referenced Headphone output drivers are designed to suppress pops and clicks when enabled or disabled. However, it is necessary to control the drivers in accordance with a defined sequence in start-up and shutdown to achieve the pop suppression. It is also necessary to schedule the DC Servo offset correction at the appropriate point in the sequence (see “DC Servo”). Table 61 and Table 62 describe the recommended sequences for enabling and disabling these output drivers.

SEQUENCE	HEADPHONE ENABLE
Step 1	HPOUT1L_ENA = 1 HPOUT1R_ENA = 1
Step 2	20 μ s delay
Step 3	HPOUT1L_DLY = 1 HPOUT1R_DLY = 1
Step 4	DC offset correction
Step 5	HPOUT1L_OUTP = 1 HPOUT1L_RMV_SHORT = 1 HPOUT1R_OUTP = 1 HPOUT1R_RMV_SHORT = 1

Table 61 Headphone Output Enable Sequence

SEQUENCE	HEADPHONE DISABLE
Step 1	HPOUT1L_RMV_SHORT = 0 HPOUT1L_DLY = 0 HPOUT1L_OUTP = 0 HPOUT1R_RMV_SHORT = 0 HPOUT1R_DLY = 0 HPOUT1R_OUTP = 0
Step 2	HPOUT1L_ENA = 0 HPOUT1R_ENA = 0

Table 62 Headphone Output Disable Sequence

The register bits relating to pop suppression control are defined in Table 63.

REGISTER ADDRESS	BIT	LABEL	DEFAULT	DESCRIPTION
R1 (0001h) Power Management (1)	9	HPOUT1L_ENA	0	Enables HPOUT1L input stage 0 = Disabled 1 = Enabled For normal operation, this bit should be set as the first step of the HPOUT1L Enable sequence.
	8	HPOUT1R_ENA	0	Enables HPOUT1R input stage 0 = Disabled 1 = Enabled For normal operation, this bit should be set as the first step of the HPOUT1R Enable sequence.
R96 (0060h) Analogue HP (1)	7	HPOUT1L_RMV_SHORT	0	Removes HPOUT1L short 0 = HPOUT1L short enabled 1 = HPOUT1L short removed For normal operation, this bit should be set as the final step of the HPOUT1L Enable sequence.
	6	HPOUT1L_OUTP	0	Enables HPOUT1L output stage 0 = Disabled 1 = Enabled For normal operation, this bit should be set to 1 after the DC offset cancellation has been scheduled.
	5	HPOUT1L_DLY	0	Enables HPOUT1L intermediate stage 0 = Disabled 1 = Enabled For normal operation, this bit should be set to 1 after the output signal path has been configured, and before DC offset cancellation is scheduled. This bit should be set with at least 20us delay after HPOUT1L_ENA.
	3	HPOUT1R_RMV_SHORT	0	Removes HPOUT1R short 0 = HPOUT1R short enabled 1 = HPOUT1R short removed For normal operation, this bit should be set as the final step of the HPOUT1R Enable sequence.
	2	HPOUT1R_OUTP	0	Enables HPOUT1R output stage 0 = Disabled 1 = Enabled For normal operation, this bit should be set to 1 after the DC offset cancellation has been scheduled.
	1	HPOUT1R_DLY	0	Enables HPOUT1R intermediate stage 0 = Disabled 1 = Enabled For normal operation, this bit should be set to 1 after the output signal path has been configured, and before DC offset cancellation is scheduled. This bit should be set with at least 20us delay after HPOUT1R_ENA.

Table 63 Headphone Output Signal Paths Control

OUTPUT MIXER CONTROL

The Output Mixer path select and volume controls are described in Table 64 for the Left Channel (MIXOUTL) and Table 65 for the Right Channel (MIXOUTR). The gain of each of input path may be controlled independently in the range 0dB to -9dB.

Note that the DAC input levels may also be controlled by the DAC digital volume controls (see “Digital to Analogue Converter (DAC)”) and the Audio Interface digital volume controls (see “Digital Volume and Filter Control”).

When using the IN2LP, IN2LN, IN2RP or IN2RN signal paths to the output mixers, the buffered VMID reference must be enabled, using the VMID_BUF_ENA register, as described in “Reference Voltages and Master Bias”.

REGISTER ADDRESS	BIT	LABEL	DEFAULT	DESCRIPTION
R45 (002Dh) Output Mixer (1)	5	IN2RN_TO_MIXOUTL	0	IN2RN to MIXOUTL Mute 0 = Mute 1 = Un-mute Note that VMID_BUF_ENA must be set when using the IN2RN input to MIXOUTL.
R49 (0031h) Output Mixer (5)	8:6	IN2RN_MIXOUTL_VOL [2:0]	000	IN2RN to MIXOUTL Volume 0dB to -9dB in 3dB steps X00 = 0dB X01 = -3dB X10 = -6dB X11 = -9dB
R45 (002Dh) Output Mixer (1)	4	IN2LN_TO_MIXOUTL	0	IN2LN to MIXOUTL Mute 0 = Mute 1 = Un-mute Note that VMID_BUF_ENA must be set when using the IN2LN input to MIXOUTL.
R47 (002Fh) Output Mixer (3)	8:6	IN2LN_MIXOUTL_VOL [2:0]	000	IN2LN to MIXOUTL Volume 0dB to -9dB in 3dB steps X00 = 0dB X01 = -3dB X10 = -6dB X11 = -9dB
R45 (002Dh) Output Mixer (1)	2	IN1L_TO_MIXOUTL	0	IN1L PGA Output to MIXOUTL Mute 0 = Mute 1 = Un-mute
R47 (002Fh) Output Mixer (3)	2:0	IN1L_MIXOUTL_VOL [2:0]	000	IN1L PGA Output to MIXOUTL Volume 0dB to -9dB in 3dB steps X00 = 0dB X01 = -3dB X10 = -6dB X11 = -9dB
R45 (002Dh) Output Mixer (1)	3	IN1R_TO_MIXOUTL	0	IN1R PGA Output to MIXOUTL Mute 0 = Mute 1 = Un-mute

REGISTER ADDRESS	BIT	LABEL	DEFAULT	DESCRIPTION
R47 (002Fh) Output Mixer (3)	5:3	IN1R_MIXOUTL_VOL [2:0]	000	IN1R PGA Output to MIXOUTL Volume 0dB to -9dB in 3dB steps X00 = 0dB X01 = -3dB X10 = -6dB X11 = -9dB
R45 (002Dh) Output Mixer (1)	1	IN2LP_TO_MIXOUTL	0	IN2LP to MIXOUTL Mute 0 = Mute 1 = Un-mute Note that VMID_BUF_ENA must be set when using the IN2LP input to MIXOUTL.
R47 (002Fh) Output Mixer (3)	11:9	IN2LP_MIXOUTL_VOL [2:0]	000	IN2LP to MIXOUTL Volume 0dB to -9dB in 3dB steps X00 = 0dB X01 = -3dB X10 = -6dB X11 = -9dB
R45 (002Dh) Output Mixer (1)	7	MIXINR_TO_MIXOUTL	0	MIXINR Output (Right ADC bypass) to MIXOUTL Mute 0 = Mute 1 = Un-mute
R49 (0031h) Output Mixer (5)	5:3	MIXINR_MIXOUTL_VO L [2:0]	000	MIXINR Output (Right ADC bypass) to MIXOUTL Volume 0dB to -9dB in 3dB steps X00 = 0dB X01 = -3dB X10 = -6dB X11 = -9dB
R45 (002Dh) Output Mixer (1)	6	MIXINL_TO_MIXOUTL	0	MIXINL Output (Left ADC bypass) to MIXOUTL Mute 0 = Mute 1 = Un-mute
R49 (0031h) Output Mixer (5)	2:0	MIXINL_MIXOUTL_VOL [2:0]	000	MIXINL Output (Left ADC bypass) to MIXOUTL Volume 0dB to -9dB in 3dB steps X00 = 0dB X01 = -3dB X10 = -6dB X11 = -9dB
R45 (002Dh) Output Mixer (1)	0	DAC1L_TO_MIXOUTL	0	Left DAC1 to MIXOUTL Mute 0 = Mute 1 = Un-mute
R49 (0031h) Output Mixer (5)	11:9	DAC1L_MIXOUTL_VOL [2:0]	000	Left DAC1 to MIXOUTL Volume 0dB to -9dB in 3dB steps X00 = 0dB X01 = -3dB X10 = -6dB X11 = -9dB

Table 64 Left Output Mixer (MIXOUTL) Control

REGISTER ADDRESS	BIT	LABEL	DEFAULT	DESCRIPTION
R46 (002Eh) Output Mixer (2)	5	IN2LN_TO_MIXOUTR	0	IN2LN to MIXOUTR Mute 0 = Mute 1 = Un-mute Note that VMID_BUF_ENA must be set when using the IN2LN input to MIXOUTR.
R50 (0032h) Output Mixer (6)	8:6	IN2LN_MIXOUTR_VOL [2:0]	000	IN2LN to MIXOUTR Volume 0dB to -9dB in 3dB steps X00 = 0dB X01 = -3dB X10 = -6dB X11 = -9dB
R46 (002Eh) Output Mixer (2)	4	IN2RN_TO_MIXOUTR	0	IN2RN to MIXOUTR Mute 0 = Mute 1 = Un-mute Note that VMID_BUF_ENA must be set when using the IN2RN input to MIXOUTR.
R48 (0030h) Output Mixer (4)	8:6	IN2RN_MIXOUTR_VOL [2:0]	000	IN2RN to MIXOUTR Volume 0dB to -9dB in 3dB steps X00 = 0dB X01 = -3dB X10 = -6dB X11 = -9dB
R46 (002Eh) Output Mixer (2)	3	IN1L_TO_MIXOUTR	0	IN1L PGA Output to MIXOUTR Mute 0 = Mute 1 = Un-mute
R48 (0030h) Output Mixer (4)	5:3	IN1L_MIXOUTR_VOL [2:0]	000	IN1L PGA Output to MIXOUTR Volume 0dB to -9dB in 3dB steps X00 = 0dB X01 = -3dB X10 = -6dB X11 = -9dB
R46 (002Eh) Output Mixer (2)	2	IN1R_TO_MIXOUTR	0	IN1R PGA Output to MIXOUTR Mute 0 = Mute 1 = Un-mute
R48 (0030h) Output Mixer (4)	2:0	IN1R_MIXOUTR_VOL [2:0]	000	IN1R PGA Output to MIXOUTR Volume 0dB to -9dB in 3dB steps X00 = 0dB X01 = -3dB X10 = -6dB X11 = -9dB
R46 (002Eh) Output Mixer (2)	1	IN2RP_TO_MIXOUTR	0	IN2RP to MIXOUTR Mute 0 = Mute 1 = Un-mute Note that VMID_BUF_ENA must be set when using the IN2RP input to MIXOUTR.

REGISTER ADDRESS	BIT	LABEL	DEFAULT	DESCRIPTION
R48 (0030h) Output Mixer (4)	11:9	IN2RP_MIXOUTR_VOL [2:0]	000	IN2RP to MIXOUTR Volume 0dB to -9dB in 3dB steps X00 = 0dB X01 = -3dB X10 = -6dB X11 = -9dB
R46 (002Eh) Output Mixer (2)	7	MIXINL_TO_MIXOUTR	0	MIXINL Output (Left ADC bypass) to MIXOUTR Mute 0 = Mute 1 = Un-mute
R50 (0032h) Output Mixer (6)	5:3	MIXINL_MIXOUTR_VO L[2:0]	000	MIXINL Output (Left ADC bypass) to MIXOUTR Volume 0dB to -9dB in 3dB steps X00 = 0dB X01 = -3dB X10 = -6dB X11 = -9dB
R46 (002Eh) Output Mixer (2)	6	MIXINR_TO_MIXOUTR	0	MIXINR Output (Right ADC bypass) to MIXOUTR Mute 0 = Mute 1 = Un-mute
R50 (0032h) Output Mixer (6)	2:0	MIXINR_MIXOUTR_VO L [2:0]	000	MIXINR Output (Right ADC bypass) to MIXOUTR Volume 0dB to -9dB in 3dB steps X00 = 0dB X01 = -3dB X10 = -6dB X11 = -9dB
R46 (002Eh) Output Mixer (2)	0	DAC1R_TO_MIXOUTR	0	Right DAC1 to MIXOUTR Mute 0 = Mute 1 = Un-mute
R50 (0032h) Output Mixer (6)	11:9	DAC1R_MIXOUTR_VO L [2:0]	000	Right DAC1 to MIXOUTR Volume 0dB to -9dB in 3dB steps X00 = 0dB X01 = -3dB X10 = -6dB X11 = -9dB

Table 65 Right Output Mixer (MIXOUTR) Control

SPEAKER MIXER CONTROL

The Speaker Mixer path select and volume controls are described in Table 66 for the Left Channel (SPKMIXL) and Table 67 for the Right Channel (SPKMIXR).

Care should be taken when enabling more than one path to a speaker mixer in order to avoid clipping. The gain of each input path is adjustable using a selectable -3dB control in each path to facilitate this. Each Speaker Mixer output is also controlled by an additional independent volume control.

Note that the DAC input levels may also be controlled by the DAC digital volume controls (see "Digital to Analogue Converter (DAC)") and the Audio Interface digital volume controls (see "Digital Volume and Filter Control").

When using the IN1LP or IN1RP signal paths to the speaker mixers, the buffered VMID reference must be enabled, using the VMID_BUF_ENA register, as described in "Reference Voltages and Master Bias".

REGISTER ADDRESS	BIT	LABEL	DEFAULT	DESCRIPTION
R54 (0034h) Speaker Mixer	9	DAC2L_TO_SPKMIXL	0	Left DAC2 to SPKMIXL Mute 0 = Mute 1 = Un-mute
	7	MIXINL_TO_SPKMIXL	0	MIXINL (Left ADC bypass) to SPKMIXL Mute 0 = Mute 1 = Un-mute
	5	IN1LP_TO_SPKMIXL	0	IN1LP to SPKMIXL Mute 0 = Mute 1 = Un-mute Note that VMID_BUF_ENA must be set when using the IN1LP input to SPKMIXL.
	3	MIXOUTL_TO_SPKMIXL	0	Left Mixer Output to SPKMIXL Mute 0 = Mute 1 = Un-mute
	1	DAC1L_TO_SPKMIXL	0	Left DAC1 to SPKMIXL Mute 0 = Mute 1 = Un-mute
R34 (0022h) SPKMIXL Attenuation	6	DAC2L_SPKMIXL_VOL	0	Left DAC2 to SPKMIXL Fine Volume Control 0 = 0dB 1 = -3dB
	5	MIXINL_SPKMIXL_VOL	0	MIXINL (Left ADC bypass) to SPKMIXL Fine Volume Control 0 = 0dB 1 = -3dB
	4	IN1LP_SPKMIXL_VOL	0	IN1LP to SPKMIXL Fine Volume Control 0 = 0dB 1 = -3dB
	3	MIXOUTL_SPKMIXL_VOL	0	Left Mixer Output to SPKMIXL Fine Volume Control 0 = 0dB 1 = -3dB
	2	DAC1L_SPKMIXL_VOL	0	Left DAC1 to SPKMIXL Fine Volume Control 0 = 0dB 1 = -3dB
	1:0	SPKMIXL_VOL [1:0]	11	Left Speaker Mixer Volume Control 00 = 0dB 01 = -6dB 10 = -12dB 11 = Mute

Table 66 Left Speaker Mixer (SPKMIXL) Control

REGISTER ADDRESS	BIT	LABEL	DEFAULT	DESCRIPTION
R54 (0034h) Speaker Mixer	8	DAC2R_TO_SPKMIXR	0	Right DAC2 to SPKMIXR Mute 0 = Mute 1 = Un-mute
	6	MIXINR_TO_SPKMIXR	0	MIXINR (Right ADC bypass) to SPKMIXR Mute 0 = Mute 1 = Un-mute
	4	IN1RP_TO_SPKMIXR	0	IN1RP to SPKMIXR Mute 0 = Mute 1 = Un-mute Note that VMID_BUF_ENA must be set when using the IN1RP input to SPKMIXR.
	2	MIXOUTR_TO_SPKMIXR	0	Right Mixer Output to SPKMIXR Mute 0 = Mute 1 = Un-mute
	0	DAC1R_TO_SPKMIXR	0	Right DAC1 to SPKMIXR Mute 0 = Mute 1 = Un-mute
R35 (0023h) SPKMIXR Attenuation	6	DAC2R_SPKMIXR_VOL	0	Right DAC2 to SPKMIXR Fine Volume Control 0 = 0dB 1 = -3dB
	5	MIXINR_SPKMIXR_VOL	0	MIXINR (Right ADC bypass) to SPKMIXR Fine Volume Control 0 = 0dB 1 = -3dB
	4	IN1RP_SPKMIXR_VOL	0	IN1RP to SPKMIXR Fine Volume Control 0 = 0dB 1 = -3dB
	3	MIXOUTR_SPKMIXR_VOL	0	Right Mixer Output to SPKMIXR Fine Volume Control 0 = 0dB 1 = -3dB
	2	DAC1R_SPKMIXR_VOL	0	Right DAC1 to SPKMIXR Fine Volume Control 0 = 0dB 1 = -3dB
	1:0	SPKMIXR_VOL [1:0]	11	Right Speaker Mixer Volume Control 00 = 0dB 01 = -6dB 10 = -12dB 11 = Mute

Table 67 Right Speaker Mixer (SPKMIXR) Control

OUTPUT SIGNAL PATH VOLUME CONTROL

There are six output PGAs - MIXOUTLVOL, MIXOUTRVOL, HPOUT1LVOL, HPOUT1RVOL, SPKLVOL and SPKRVOL. Each can be independently controlled, with MIXOUTLVOL and MIXOUTRVOL providing volume control to both the earpiece and line drivers, HPOUT1LVOL and HPOUT1RVOL to the headphone driver, and SPKLVOL and SPKRVOL to the speaker drivers.

The volume control of each of these output PGAs can be adjusted over a wide range of values. To minimise pop noise, it is recommended that only the MIXOUTLVOL, MIXOUTRVOL, HPOUT1LVOL, HPOUT1RVOL, SPKLVOL and SPKRVOL are modified while the output signal path is active. Other gain controls are provided in the signal paths to provide scaling of signals from different sources, and to prevent clipping when multiple signals are mixed. However, to prevent pop noise, it is recommended that those other gain controls should not be modified while the signal path is active.

To prevent "zipper noise", a zero-cross function is provided on the output PGAs. When this feature is enabled, volume updates will not take place until a zero-crossing is detected. In the case of a long period without zero-crossings, a timeout function is provided. When the zero-cross function is enabled, the volume will update after the timeout period if no earlier zero-cross has occurred. The timeout clock is enabled using TOCLK_ENA; the timeout period is set by TOCLK_DIV. See "Clocking and Sample Rates" for more information on these fields.

The mixer output PGA controls are shown in Table 68. The MIXOUT_VU bits control the loading of the output mixer PGA volume data. When MIXOUT_VU is set to 0, the volume control data will be loaded into the respective control register, but will not actually change the gain setting. The output mixer PGA volume settings are both updated when a 1 is written to either MIXOUT_VU bit. This makes it possible to update the gain of both output paths simultaneously.

REGISTER ADDRESS	BIT	LABEL	DEFAULT	DESCRIPTION
R32 (0020h) Left OPGA Volume	8	MIXOUT_VU	N/A	Mixer Output PGA Volume Update Writing a 1 to this bit will update MIXOUTLVOL and MIXOUTRVOL volumes simultaneously.
	7	MIXOUTL_ZC	0	MIXOUTLVOL (Left Mixer Output PGA) Zero Cross Enable 0 = Zero cross disabled 1 = Zero cross enabled
	6	MIXOUTL_MUTE_N	1	MIXOUTLVOL (Left Mixer Output PGA) Mute 0 = Mute 1 = Un-mute
	5:0	MIXOUTL_VOL [5:0]	39h (0dB)	MIXOUTLVOL (Left Mixer Output PGA) Volume -57dB to +6dB in 1dB steps 00_0000 = -57dB 00_0001 = -56dB ... (1dB steps) 11_1111 = +6dB (See Table 71 for output PGA volume control range)
R33 (0021h) Right OPGA Volume	8	MIXOUT_VU	N/A	Mixer Output PGA Volume Update Writing a 1 to this bit will update MIXOUTLVOL and MIXOUTRVOL volumes simultaneously.
	7	MIXOUTR_ZC	0	MIXOUTRVOL (Right Mixer Output PGA) Zero Cross Enable 0 = Zero cross disabled 1 = Zero cross enabled
	6	MIXOUTR_MUTE_N	1	MIXOUTRVOL (Right Mixer Output PGA) Mute 0 = Mute 1 = Un-mute

REGISTER ADDRESS	BIT	LABEL	DEFAULT	DESCRIPTION
	5:0	MIXOUTR_VOL [5:0]	39h (0dB)	MIXOUTRVOL (Right Mixer Output PGA) Volume -57dB to +6dB in 1dB steps 00_0000 = -57dB 00_0001 = -56dB ... (1dB steps) 11_1111 = +6dB (See Table 71 for output PGA volume control range)

Table 68 Mixer Output PGA (MIXOUTLVOL, MIXOUTRVOL) Control

The headphone output PGA is configurable between two input sources. The default input to each headphone output PGA is the respective output mixer (MIXOUTL or MIXOUTR). A direct path from the DAC1L or DAC1R can be selected using the DAC1L_TO_HPOUT1L and DAC1R_TO_HPOUT1R register bits. When these bits are selected, a DAC to Headphone playback path is possible without using the output mixers; this offers reduced power consumption by allowing the output mixers to be disabled in this typical usage case.

The headphone output PGA controls are shown in Table 69. The HPOUT1_VU bits control the loading of the headphone PGA volume data. When HPOUT1_VU is set to 0, the volume control data will be loaded into the respective control register, but will not actually change the gain setting. The headphone PGA volume settings are both updated when a 1 is written to either HPOUT1_VU bit. This makes it possible to update the gain of both output paths simultaneously.

REGISTER ADDRESS	BIT	LABEL	DEFAULT	DESCRIPTION
R28 (001Ch) Left Output Volume	8	HPOUT1_VU	N/A	Headphone Output PGA Volume Update Writing a 1 to this bit will update HPOUT1LVOL and HPOUT1RVOL volumes simultaneously.
	7	HPOUT1L_ZC	0	HPOUT1LVOL (Left Headphone Output PGA) Zero Cross Enable 0 = Zero cross disabled 1 = Zero cross enabled
	6	HPOUT1L_MUTE_N	1	HPOUT1LVOL (Left Headphone Output PGA) Mute 0 = Mute 1 = Un-mute
	5:0	HPOUT1L_VOL [5:0]	2Dh (-12dB)	HPOUT1LVOL (Left Headphone Output PGA) Volume -57dB to +6dB in 1dB steps 00_0000 = -57dB 00_0001 = -56dB ... (1dB steps) 11_1111 = +6dB (See Table 71 for output PGA volume control range)
R45 (002Dh) Output Mixer (1)	8	DAC1L_TO_HPOUT1L	0	HPOUT1LVOL (Left Headphone Output PGA) Input Select 0 = MIXOUTL 1 = DAC1L
R29 (001Dh) Right Output Volume	8	HPOUT1_VU	N/A	Headphone Output PGA Volume Update Writing a 1 to this bit will update HPOUT1LVOL and HPOUT1RVOL volumes simultaneously.

REGISTER ADDRESS	BIT	LABEL	DEFAULT	DESCRIPTION
	7	HPOUT1R_ZC	0	HPOUT1RVOL (Right Headphone Output PGA) Zero Cross Enable 0 = Zero cross disabled 1 = Zero cross enabled
	6	HPOUT1R_MUTE_N	1	HPOUT1RVOL (Right Headphone Output PGA) Mute 0 = Mute 1 = Un-mute
	5:0	HPOUT1R_VOL [5:0]	2Dh (-12dB)	HPOUT1RVOL (Right Headphone Output PGA) Volume -57dB to +6dB in 1dB steps 00_0000 = -57dB 00_0001 = -56dB ... (1dB steps) 11_1111 = +6dB (See Table 71 for output PGA volume control range)
R46 (002Eh) Output Mixer (2)	8	DAC1R_TO_HPOUT1R	0	HPOUT1RVOL (Right Headphone Output PGA) Input Select 0 = MIXOUTR 1 = DAC1R

Table 69 Headphone Output PGA (HPOUT1LVOL, HPOUT1RVOL) Control

The speaker output PGA controls are shown in Table 70. The SPKOUT_VU bits control the loading of the speaker PGA volume data. When SPKOUT_VU is set to 0, the volume control data will be loaded into the respective control register, but will not actually change the gain setting. The speaker PGA volume settings are both updated when a 1 is written to either SPKOUT_VU bit. This makes it possible to update the gain of both output paths simultaneously.

REGISTER ADDRESS	BIT	LABEL	DEFAULT	DESCRIPTION
R38 (0026h) Speaker Volume Left	8	SPKOUT_VU	N/A	Speaker Output PGA Volume Update Writing a 1 to this bit will update SPKLVOL and SPKRVOL volumes simultaneously.
	7	SPKOUTL_ZC	0	SPKLVOL (Left Speaker Output PGA) Zero Cross Enable 0 = Zero cross disabled 1 = Zero cross enabled
	6	SPKOUTL_MUTE_N	1	SPKLVOL (Left Speaker Output PGA) Mute 0 = Mute 1 = Un-mute
	5:0	SPKOUTL_VOL [5:0]	39h (0dB)	SPKLVOL (Left Speaker Output PGA) Volume -57dB to +6dB in 1dB steps 00_0000 = -57dB 00_0001 = -56dB ... (1dB steps) 11_1111 = +6dB (See Table 71 for output PGA volume control range)

REGISTER ADDRESS	BIT	LABEL	DEFAULT	DESCRIPTION
R39 (0027h) Speaker Volume Right	8	SPKOUT_VU	N/A	Speaker PGA Volume Update Writing a 1 to this bit will update SPKLVOL and SPKRVOL volumes simultaneously.
	7	SPKOUTR_ZC	0	SPKRVOL (Right Speaker Output PGA) Zero Cross Enable 0 = Zero cross disabled 1 = Zero cross enabled
	6	SPKOUTR_MUTE_N	1	SPKRVOL (Right Speaker Output PGA) Mute 0 = Mute 1 = Un-mute
	5:0	SPKOUTR_VOL [5:0]	39h (0dB)	SPKRVOL (Right Speaker Output PGA) Volume -57dB to +6dB in 1dB steps 00_0000 = -57dB 00_0001 = -56dB ... (1dB steps) 11_1111 = +6dB (See Table 71 for output PGA volume control range)

Table 70 Speaker Output PGA (SPKLVOL, SPKRVOL) Control

PGA GAIN SETTING	VOLUME (dB)	PGA GAIN SETTING	VOLUME (dB)
00h	-57	20h	-25
01h	-56	21h	-24
02h	-55	22h	-23
03h	-54	23h	-22
04h	-53	24h	-21
05h	-52	25h	-20
06h	-51	26h	-19
07h	-50	27h	-18
08h	-49	28h	-17
09h	-48	29h	-16
0Ah	-47	2Ah	-15
0Bh	-46	2Bh	-14
0Ch	-45	2Ch	-13
0Dh	-44	2Dh	-12
0Eh	-43	2Eh	-11
0Fh	-42	2Fh	-10
10h	-41	30h	-9
11h	-40	31h	-8
12h	-39	32h	-7
13h	-38	33h	-6
14h	-37	34h	-5
15h	-36	35h	-4
16h	-35	36h	-3
17h	-34	37h	-2
18h	-33	38h	-1
19h	-32	39h	0
1Ah	-31	3Ah	+1
1Bh	-30	3Bh	+2
1Ch	-29	3Ch	+3

PGA GAIN SETTING	VOLUME (dB)	PGA GAIN SETTING	VOLUME (dB)
1Dh	-28	3Dh	+4
1Eh	-27	3Eh	+5
1Fh	-26	3Fh	+6

Table 71 Output PGA Volume Range

SPEAKER BOOST MIXER

Each Class D/AB speaker driver has its own boost mixer which performs a dual role. It allows the output from the left speaker mixer (via SPKLVOL), right speaker mixer (via SPKRVOL), or the 'Direct Voice' path to be routed to either speaker driver. The speaker boost mixers are controlled using the registers defined in Table 72 below.

The 'Direct Voice' path is the differential input, VRXN-VRXP, routed directly to the output drivers, providing a low power differential path from baseband voice to loudspeakers. Note that a phase inversion exists between VRXP and SPKOUTxP. The 'Direct Voice' path output therefore represents $V_{VRXN} - V_{VRXP}$.

The second function of the speaker boost mixers is that they provide an additional AC gain (boost) function to shift signal levels between the AVDD1 and SPKVDD voltage domains for maximum output power. The AC gain (boost) function is described in the "Analogue Outputs" section.

REGISTER ADDRESS	BIT	LABEL	DEFAULT	DESCRIPTION
R36 (0024h) SPKOUT Mixers	5	IN2LRP_TO_SPKOUT L	0	Direct Voice (VRXN-VRXP) to Left Speaker Mute 0 = Mute 1 = Un-mute
	4	SPKMIXL_TO_SPKOU TL	1	SPKMIXL Left Speaker Mixer to Left Speaker Mute 0 = Mute 1 = Un-mute
	3	SPKMIXR_TO_SPKO UTL	0	SPKMIXR Right Speaker Mixer to Left Speaker Mute 0 = Mute 1 = Un-mute
	2	IN2LRP_TO_SPKOUT R	0	Direct Voice (VRXN-VRXP) to Right Speaker Mute 0 = Mute 1 = Un-mute
	1	SPKMIXL_TO_SPKOU TR	0	SPKMIXL Left Speaker Mixer to Right Speaker Mute 0 = Mute 1 = Un-mute
	0	SPKMIXR_TO_SPKO UTR	1	SPKMIXR Right Speaker Mixer to Right Speaker Mute 0 = Mute 1 = Un-mute

Table 72 Speaker Boost Mixer (SPKOUTLBOOST, SPKOUTRBOOST) Control

EARPIECE DRIVER MIXER

The earpiece driver has a dedicated mixer, HPOUT2MIX, which is controlled using the registers defined in Table 73. The earpiece driver is configurable to select output from the left output mixer (via MIXOUTLVOL), the right output mixer (via MIXOUTRVOL), or the 'Direct Voice' path.

The 'Direct Voice' path is the differential input, VRXN-VRXP, routed directly to the output drivers, providing a low power differential path from baseband voice to earpiece. Note that a phase inversion exists between VRXP and HPOUT2P. The 'Direct Voice' path output therefore represents $V_{VRXN} - V_{VRXP}$.

Care should be taken to avoid clipping when enabling more than one path to the earpiece driver. The HPOUT2VOL volume control can be used to avoid clipping when more than one full scale signal is input to the mixer.

REGISTER ADDRESS	BIT	LABEL	DEFAULT	DESCRIPTION
R31 (001Fh) HPOUT2 Volume	5	HPOUT2_MUTE	1	HPOUT2 (Earpiece Driver) Mute 0 = Un-mute 1 = Mute
	4	HPOUT2_VOL	0	HPOUT2 (Earpiece Driver) Volume 0 = 0dB 1 = -6dB
R51 (0033h) HPOUT2 Mixer	5	IN2LRP_TO_HPOUT2	0	Direct Voice (VRXN-VRXP) to Earpiece Driver 0 = Mute 1 = Un-mute
	4	MIXOUTLVOL_TO_HP OUT2	0	MIXOUTLVOL (Left Output Mixer PGA) to Earpiece Driver 0 = Mute 1 = Un-mute
	3	MIXOUTRVOL_TO_HP OUT2	0	MIXOUTRVOL (Right Output Mixer PGA) to Earpiece Driver 0 = Mute 1 = Un-mute

Table 73 Earpiece Driver Mixer (HPOUT2MIX) Control

LINE OUTPUT MIXERS

The WM8958 provides two pairs of line outputs, both with highly configurable output mixers. The outputs LINEOUT1N and LINEOUT1P can be configured as two single-ended outputs or as a differential output. In the same manner, LINEOUT2N and LINEOUT2P can be configured either as two single-ended outputs or as a differential output. The respective line output mixers can be configured in single-ended mode or differential mode; each mode supports multiple signal path configurations.

LINEOUT1 single-ended mode is selected by setting LINEOUT1_MODE = 1. In single-ended mode, any of three possible signal paths may be enabled:

- MIXOUTL (left output mixer) to LINEOUT1P
- MIXOUTR (right output mixer) to LINEOUT1N
- MIXOUTL (left output mixer) to LINEOUT1N

LINEOUT1 differential mode is selected by setting LINEOUT1_MODE = 0. In differential mode, any of three possible signal paths may be enabled:

- MIXOUTL (left output mixer) to LINEOUT1N and LINEOUT1P
- IN1L (input PGA) to LINEOUT1N and LINEOUT1P
- IN1R (input PGA) to LINEOUT1N and LINEOUT1P

The LINEOUT1 output mixers are controlled as described in Table 74. Care should be taken to avoid clipping when enabling more than one path to the line output mixers. The LINEOUT1_VOL control can be used to provide -6dB attenuation when more than one full scale signal is applied.

When using the LINEOUT1 mixers in single-ended mode, a buffered VMID must be enabled. This is achieved by setting LINEOUT_VMID_BUF_ENA, as described in the "Analogue Outputs" section.

REGISTER ADDRESS	BIT	LABEL	DEFAULT	DESCRIPTION
R30 (001Eh) Line Outputs Volume	6	LINEOUT1N_MUTE	1	LINEOUT1N Line Output Mute 0 = Un-mute 1 = Mute
	5	LINEOUT1P_MUTE	1	LINEOUT1P Line Output Mute 0 = Un-mute 1 = Mute
	4	LINEOUT1_VOL	0	LINEOUT1 Line Output Volume 0 = 0dB 1 = -6dB Applies to both LINEOUT1N and LINEOUT1P
R52 (0034h) Line Mixer (1)	6	MIXOUTL_TO_LINEO UT1N	0	MIXOUTL to Single-Ended Line Output on LINEOUT1N 0 = Mute 1 = Un-mute (LINEOUT1_MODE = 1)
	5	MIXOUTR_TO_LINE OUT1N	0	MIXOUTR to Single-Ended Line Output on LINEOUT1N 0 = Mute 1 = Un-mute (LINEOUT1_MODE = 1)
	4	LINEOUT1_MODE	0	LINEOUT1 Mode Select 0 = Differential 1 = Single-Ended
	2	IN1R_TO_LINEOUT1 P	0	IN1R Input PGA to Differential Line Output on LINEOUT1 0 = Mute 1 = Un-mute (LINEOUT1_MODE = 0)
	1	IN1L_TO_LINEOUT1 P	0	IN1L Input PGA to Differential Line Output on LINEOUT1 0 = Mute 1 = Un-mute (LINEOUT1_MODE = 0)
	0	MIXOUTL_TO_LINEO UT1P	0	Differential Mode (LINEOUT1_MODE = 0): MIXOUTL to Differential Output on LINEOUT1 0 = Mute 1 = Un-mute Single Ended Mode (LINEOUT1_MODE = 1): MIXOUTL to Single-Ended Line Output on LINEOUT1P 0 = Mute 1 = Un-mute

Table 74 LINEOUT1N and LINEOUT1P Control

LINEOUT2 single-ended mode is selected by setting `LINEOUT2_MODE = 1`. In single-ended mode, any of three possible signal paths may be enabled:

- MIXOUTR (right output mixer) to LINEOUT2P
- MIXOUTL (left output mixer) to LINEOUT2N
- MIXOUTR (right output mixer) to LINEOUT2N

LINEOUT2 differential mode is selected by setting `LINEOUT2_MODE = 0`. In differential mode, any of three possible signal paths may be enabled:

- MIXOUTR (right output mixer) to LINEOUT2N and LINEOUT2P
- IN1L (input PGA) to LINEOUT2P and LINEOUT2N
- IN1R (input PGA) to LINEOUT2N and LINEOUT2P

The LINEOUT2 output mixers are controlled as described in Table 75. Care should be taken to avoid clipping when enabling more than one path to the line output mixers. The `LINEOUT2_VOL` control can be used to provide -6dB attenuation when more than one full scale signal is applied.

When using the LINEOUT2 mixers in single-ended mode, a buffered VMID must be enabled. This is achieved by setting `LINEOUT_VMID_BUF_ENA`, as described in the "Analogue Outputs" section.

REGISTER ADDRESS	BIT	LABEL	DEFAULT	DESCRIPTION
R30 (001Eh) Line Outputs Volume	2	LINEOUT2N_MUTE	1	LINEOUT2N Line Output Mute 0 = Un-mute 1 = Mute
	1	LINEOUT2P_MUTE	1	LINEOUT2P Line Output Mute 0 = Un-mute 1 = Mute
	0	LINEOUT2_VOL	0	LINEOUT2 Line Output Volume 0 = 0dB 1 = -6dB Applies to both LINEOUT2N and LINEOUT2P
R53 (0035h) Line Mixer (2)	6	MIXOUTR_TO_LINEO UT2N	0	MIXOUTR to Single-Ended Line Output on LINEOUT2N 0 = Mute 1 = Un-mute (LINEOUT2_MODE = 1)
	5	MIXOUTL_TO_LINEO UT2N	0	MIXOUTL to Single-Ended Line Output on LINEOUT2N 0 = Mute 1 = Un-mute (LINEOUT2_MODE = 1)
	4	LINEOUT2_MODE	0	LINEOUT2 Mode Select 0 = Differential 1 = Single-Ended
	2	IN1L_TO_LINEOUT2P	0	IN1L Input PGA to Differential Line Output on LINEOUT2 0 = Mute 1 = Un-mute (LINEOUT2_MODE = 0)
	1	IN1R_TO_LINEOUT2P	0	IN1R Input PGA to Differential Line Output on LINEOUT2 0 = Mute 1 = Un-mute (LINEOUT2_MODE = 0)
	0	MIXOUTR_TO_LINEO UT2P	0	Differential Mode (LINEOUT2_MODE = 0): MIXOUTR to Differential Output on LINEOUT2 0 = Mute 1 = Un-mute Single-Ended Mode (LINEOUT2_MODE = 0): MIXOUTR to Single-Ended Line Output on LINEOUT2P 0 = Mute 1 = Un-mute

Table 75 LINEOUT2N and LINEOUT2P Control

CHARGE PUMP

The WM8958 incorporates a dual-mode Charge Pump which generates the supply rails for the headphone output drivers, HPOUT1L and HPOUT1R.

The Charge Pump has a single supply input, CPVDD, and generates split rails CPVOUTP and CPVOUTN according to the selected mode of operation.

The Charge Pump connections are illustrated in Figure 31 (see “Applications Information” for external component values). An input decoupling capacitor may also be required at CPVDD, depending upon the system configuration.

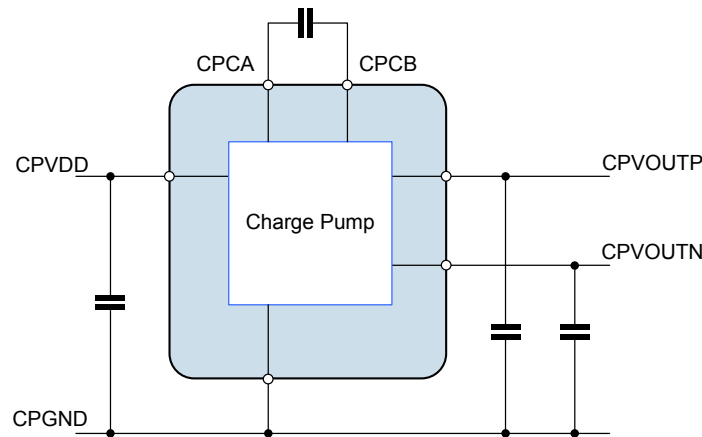

Figure 31 Charge Pump External Connections

The Charge Pump is enabled by setting the CP_ENA bit. When enabled, the charge pump adjusts the output voltages (CPVOUTP and CPVOUTN) as well as the switching frequency in order to optimise the power consumption according to the operating conditions. This can take two forms, which are selected using the CP_DYN_PWR register bit.

- Register control (CP_DYN_PWR = 0)
- Dynamic control (CP_DYN_PWR = 1)

Under Register control, the HPOUT1L_VOL and HPOUT1R_VOL register settings are used to control the charge pump mode of operation.

Under Dynamic control, the audio signal level in the digital audio interface is used to control the charge pump mode of operation. The CP_DYN_SRC_SEL register determines which of the digital signal paths is used for this function - this may be AIF1 Timeslot 0, AIF Timeslot 1 or AIF2. The CP_DYN_SRC_SEL should be set according to the active source for the HPOUT1L and HPOUT1R outputs.

The Dynamic Charge Pump Control mode is the Wolfson ‘Class W’ mode, which allows the power consumption to be optimised in real time, but can only be used if a single AIF source is the only signal source. The Class W mode should not be used if any of the bypass paths are used to feed analogue inputs into the output signal path, or if more than one AIF source is used to feed the headphone output via the Digital Mixers.

Under the recommended usage conditions of the WM8958, the Charge Pump will be enabled by running the default headphone Start-Up sequence as described in the “Control Write Sequence” section. (Similarly, it will be disabled by running the Shut-Down sequence.) In these cases, the user does not need to write to the CP_ENA bit. The Charge Pump operating mode defaults to Register control; Dynamic control may be selected by setting the CP_DYN_PWR register bit, if appropriate.

Note that the charge pump clock is derived from internal clock SYSCLK; either MCLK or the FLL output selectable using the SYSCLK_SRC bit. Under normal circumstances an external clock signal must be present for the charge pump to function. However, the FLL has a free-running mode that does not require an external clock but will generate an internal clock suitable for running the charge pump. The clock division from SYSCLK is handled transparently by the WM8958 without user

intervention, as long as SYSCLK and sample rates are set correctly. Refer to the “Clocking and Sample Rates” section for more detail on the FLL and clocking configuration.

When the Charge Pump is disabled, the output can be left floating or can be actively discharged, depending on the CP_DISCH control bit.

If the headphone output drivers (HPOUT1L and HPOUT1R) are not used, then the Charge Pump and the associated external components are not required. The Charge Pump and Headphone drivers should not be enabled in this case (CP_ENA=0, HPOUT1L_ENA=0, HPOUT1R_ENA=0).

If the Charge Pump is not used, and the associated external components are omitted, then the CPCA and CPCB pins can be left floating; the CPVOUTP and CPVOUTN pins should be grounded as illustrated in Figure 32.

Note that, when the Charge Pump is disabled, it is still recommended that the CPVDD pin is kept within its recommended operating conditions.

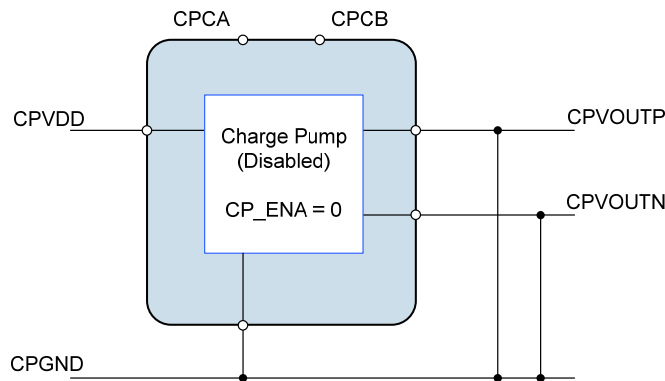

Figure 32 External Configuration when Charge Pump not used

The Charge Pump control fields are described in Table 76.

REGISTER ADDRESS	BIT	LABEL	DEFAULT	DESCRIPTION
R76 (004Ch) Charge Pump (1)	15	CP_ENA	0	Enable charge-pump digits 0 = Disable 1 = Enable
R77 (004Dh) Charge Pump (2)	15	CP_DISCH	1	Charge Pump Discharge Select 0 = Charge Pump outputs floating when disabled 1 = Charge Pump outputs discharged when disabled
R81 (0051h) Class W (1)	9:8	CP_DYN_SRC_SEL	00	Selects the digital audio source for envelope tracking 00 = AIF1, DAC Timeslot 0 01 = AIF1, DAC Timeslot 1 10 = AIF2, DAC data 11 = Reserved
	0	CP_DYN_PWR	0	Enable dynamic charge pump power control 0 = charge pump controlled by volume register settings (Class G) 1 = charge pump controlled by real-time audio level (Class W)

Table 76 Charge Pump Control

DC SERVO

The WM8958 provides a DC servo circuit on the headphone outputs HPOUT1L and HPOUT1R in order to remove DC offset from these ground-referenced outputs. When enabled, the DC servo ensures that the DC level of these outputs remains within 1mV of ground. Removal of the DC offset is important because any deviation from GND at the output pin will cause current to flow through the load under quiescent conditions, resulting in increased power consumption. Additionally, the presence of DC offsets can result in audible pops and clicks at power up and power down.

The recommended usage of the DC Servo is initialised by running the default Start-Up sequence as described in the “Control Write Sequencer” section. The default Start-Up sequence executes a series of DC offset corrections, after which the measured offset correction is maintained on the headphone output channels. If a different usage is required, eg. if a periodic DC offset correction is required, then the default Start-Up sequence may be modified according to specific requirements. The relevant control fields are described in the following paragraphs and are defined in Table 77.

DC SERVO ENABLE AND START-UP

The DC Servo circuit is enabled on HPOUT1L and HPOUT1R by setting DCS_ENA_CHAN_0 and DCS_ENA_CHAN_1 respectively. When the DC Servo is enabled, the DC offset correction can be commanded in a number of different ways, including single-shot and periodically recurring events.

Writing a logic 1 to DCS_TRIG_STARTUP_n initiates a series of DC offset measurements and applies the necessary correction to the associated output; ('n' = 0 for Left channel, 1 for Right channel). On completion, the headphone output will be within 1mV of AGND. This is the DC Servo mode selected by the default Start-Up sequence. Completion of the DC offset correction triggered in this way is indicated by the DCS_STARTUP_COMPLETE field, as described in Table 77. Typically, this operation takes 86ms per channel.

For correct operation of the DC Servo Start-Up mode, it is important that there is no active audio signal present on the signal path while the mode is running. The DC Servo Start-Up mode should be scheduled at the correct position within the Headphone Output Enable sequence, as described in the “Analogue Output Signal Path” section. All other stages of the analogue signal path should be fully enabled prior to commanding the Start-Up mode; the DAC Digital Mute function should be used, where appropriate, to ensure there is no active audio signal present during the DC Servo measurements.

Writing a logic 1 to DCS_TRIG_DAC_WR_n causes the DC offset correction to be set to the value contained in the DCS_DAC_WR_VAL_n fields in Register R87. This mode is useful if the required offset correction has already been determined and stored; it is faster than the DCS_TRIG_STARTUP_n mode, but relies on the accuracy of the stored settings. Completion of the DC offset correction triggered in this way is indicated by the DCS_DAC_WR_COMPLETE field, as described in Table 77. Typically, this operation takes 2ms per channel.

For pop-free operation of the DC Servo DAC Write mode, it is important that the mode is scheduled at the correct position within the Headphone Output Enable sequence, as described in the “Analogue Output Signal Path” section.

The current DC offset value for each Headphone output channel can be read from the DCS_DAC_WR_VAL_n fields. These values may form the basis of settings that are subsequently used by the DC Servo in DAC Write mode. Note that these fields have a different definition for Read and Write, as described in Table 77.

When using either of the DC Servo options above, the status of the DC offset correction process is indicated by the DCS_CAL_COMPLETE field; this is the logical OR of the DCS_STARTUP_COMPLETE and DCS_DAC_WR_COMPLETE fields.

The DCS_DAC_WR_COMPLETE bits can be used as inputs to the Interrupt control circuit or used to generate an external logic signal on a GPIO pin. See “Interrupts” and “General Purpose Input/Output” for further details.

The DC Servo control fields associated with start-up operation are described in Table 77. It is important to note that, to minimise audible pops/clicks, the Start-Up and DAC Write modes of DC Servo operation should be commanded as part of a control sequence which includes muting and shorting of the headphone outputs; a suitable sequence is defined in the default Start-Up sequence.

REGISTER ADDRESS	BIT	LABEL	DEFAULT	DESCRIPTION
R84 (0054h) DC Servo (1)	5	DCS_TRIG_START UP_1	0	Writing 1 to this bit selects Start-Up DC Servo mode for HPOUT1R. In readback, a value of 1 indicates that the DC Servo Start-Up correction is in progress.
	4	DCS_TRIG_START UP_0	0	Writing 1 to this bit selects Start-Up DC Servo mode for HPOUT1L. In readback, a value of 1 indicates that the DC Servo Start-Up correction is in progress.
	3	DCS_TRIG_DAC_W R_1	0	Writing 1 to this bit selects DAC Write DC Servo mode for HPOUT1R. In readback, a value of 1 indicates that the DC Servo DAC Write correction is in progress.
	2	DCS_TRIG_DAC_W R_0	0	Writing 1 to this bit selects DAC Write DC Servo mode for HPOUT1L. In readback, a value of 1 indicates that the DC Servo DAC Write correction is in progress.
	1	DCS_ENA_CHAN_1	0	DC Servo enable for HPOUT1R 0 = Disabled 1 = Enabled
	0	DCS_ENA_CHAN_0	0	DC Servo enable for HPOUT1L 0 = Disabled 1 = Enabled
R87 (0057h) DC Servo (4)	15:8	DCS_DAC_WR_VA L_1 [7:0]	00h	Writing to this field sets the DC Offset value for HPOUT1R in DAC Write DC Servo mode. Reading this field gives the current DC Offset value for HPOUT1R. Two's complement format. LSB is 0.25mV. Range is -32mV to +31.75mV
	7:0	DCS_DAC_WR_VA L_0 [7:0]	00h	Writing to this field sets the DC Offset value for HPOUT1L in DAC Write DC Servo mode. Reading this field gives the current DC Offset value for HPOUT1L. Two's complement format. LSB is 0.25mV. Range is -32mV to +31.75mV
R88 (0058h) DC Servo Readback	9:8	DCS_CAL_COMPL ETE [1:0]	00	DC Servo Complete status 0 = DAC Write or Start-Up DC Servo mode not completed. 1 = DAC Write or Start-Up DC Servo mode complete. Bit [1] = HPOUT1R Bit [0] = HPOUT1L

REGISTER ADDRESS	BIT	LABEL	DEFAULT	DESCRIPTION
	5:4	DCS_DAC_WR_COMPLETE [1:0]	00	DC Servo DAC Write status 0 = DAC Write DC Servo mode not completed. 1 = DAC Write DC Servo mode complete. Bit [1] = HPOUT1R Bit [0] = HPOUT1L
	1:0	DCS_STARTUP_COMPLETE [1:0]	00	DC Servo Start-Up status 0 = Start-Up DC Servo mode not completed. 1 = Start-Up DC Servo mode complete. Bit [1] = HPOUT1R Bit [0] = HPOUT1L

Table 77 DC Servo Enable and Start-Up Modes

DC SERVO ACTIVE MODES

The DC Servo modes described above are suitable for initialising the DC offset correction circuit on the Headphone outputs as part of a controlled start-up sequence which is executed before the signal path is fully enabled. Additional modes are available for use whilst the signal path is active; these modes may be of benefit following a large change in signal gain, which can lead to a change in DC offset level. Periodic updates may also be desirable to remove slow drifts in DC offset caused by changes in parameters such as device temperature.

The DC Servo circuit is enabled on HPOUT1L and HPOUT1R by setting DCS_ENA_CHAN_0 and DCS_ENA_CHAN_1 respectively, as described earlier in Table 77.

Writing a logic 1 to DCS_TRIG_SINGLE_n initiates a single DC offset measurement and adjustment to the associated output; ('n' = 0 for Left channel, 1 for Right channel). This will adjust the DC offset correction on the selected channel by no more than 1LSB (0.25mV).

Setting DCS_TIMER_PERIOD_01 to a non-zero value will cause a single DC offset measurement and adjustment to be scheduled on a periodic basis. Periodic rates ranging from every 0.52s to in excess of 2 hours can be selected.

Writing a logic 1 to DCS_TRIG_SERIES_n initiates a series of DC offset measurements and applies the necessary correction to the associated output. The number of DC Servo operations performed is determined by DCS_SERIES_NO_01. A maximum of 128 operations may be selected, though a much lower value will be sufficient in most applications.

The DC Servo control fields associated with active modes (suitable for use on a signal path that is in active use) are described in Table 78.

REGISTER ADDRESS	BIT	LABEL	DEFAULT	DESCRIPTION
R84 (0054h) DC Servo (1)	13	DCS_TRIG_SINGLE_1	0	Writing 1 to this bit selects a single DC offset correction for HPOUT1R. In readback, a value of 1 indicates that the DC Servo single correction is in progress.
	12	DCS_TRIG_SINGLE_0	0	Writing 1 to this bit selects a single DC offset correction for HPOUT1L. In readback, a value of 1 indicates that the DC Servo single correction is in progress.
	9	DCS_TRIG_SERIES_1	0	Writing 1 to this bit selects a series of DC offset corrections for HPOUT1R. In readback, a value of 1 indicates that the DC Servo DAC Write correction is in progress.
	8	DCS_TRIG_SERIES_0	0	Writing 1 to this bit selects a series of DC offset corrections for HPOUT1L. In readback, a value of 1 indicates that the DC Servo DAC Write correction is in progress.
R85 (0055h) DC Servo (2)	11:5	DCS_SERIES_NO_01 [6:0]	010 1010	Number of DC Servo updates to perform in a series event. 0 = 1 update 1 = 2 updates ... 127 = 128 updates
	3:0	DCS_TIMER_PERIOD_01 [3:0]	1010	Time between periodic updates. Time is calculated as $0.251s \times (2^{\text{PERIOD}})$, where PERIOD = DCS_TIMER_PERIOD_01. 0000 = Off 0001 = 0.502s 1010 = 257s (4min 17s) 1111 = 8225s (2hr 17min)

Table 78 DC Servo Active Modes

GPIO / INTERRUPT OUTPUTS FROM DC SERVO

When using the DC Servo Start-Up or DAC Write modes, the DCS_CAL_COMPLETE register provides readback of the status of the DC offset correction. This can be read from register R88 as described in Table 77.

The DCS_CAL_COMPLETE bits can also be used as inputs to the Interrupt control circuit and used to trigger an Interrupt event - see "Interrupts".

The DCS_CAL_COMPLETE bits can also be used as inputs to the GPIO function and used to generate external logic signals indicating the DC Servo status. See "General Purpose Input/Output" for details of how to configure a GPIO pin to output the DC Servo status.

ANALOGUE OUTPUTS

The speaker, headphone, earpiece and line outputs are highly configurable and may be used in many different ways.

SPEAKER OUTPUT CONFIGURATIONS

The speaker outputs SPKOUTL and SPKOUTR can be driven by either of the speaker mixers, SPKMIXL or SPKMIXR, or by the low power, differential Direct Voice path from IN2LP/VRXN and IN2RP/VRXP. Fine volume control is available on the speaker mixer paths using the SPKLVOL and SPKRVOL PGAs. A boost function is available on both the speaker mixer paths and the Direct Voice path. For information on the speaker mixing options, refer to the “Analogue Output Signal Path” section.

The speaker outputs SPKOUTL and SPKOUTR operate in a BTL configuration in Class AB or Class D amplifier modes. The default mode is Class D, but Class AB mode can be selected by setting the SPKOUT_CLASSAB register bit, as defined in Table 80.

The speaker outputs can be configured as a pair of stereo outputs, or as a single mono output. Note that, for applications requiring only a single speaker output, it is possible to improve the THD performance by configuring the speaker outputs in mono mode. See “Typical Performance” for further details.

The mono configuration is selected by applying a logic high input to the SPKMODE pin (A4), as described in Table 79. For Stereo mode this pin should be connected to GND. Note that SPKMODE is referenced to DBVDD1.

An internal pull-up resistor is enabled by default on the SPKMODE pin; this can be configured using the SPKMODE_PU register bit described in Table 80.

SPEAKER CONFIGURATION	SPKMODE PIN (A4)
Stereo Mode	GND
Mono Mode	DBVDD1

Table 79 SPKMODE Pin Function

In the mono configuration, the P channels, SPKOUTLP and SPKOUTRP should be connected together on the PCB, and similarly with the N channels, SPKOUTLN and SPKOUTRN, as illustrated in Figure 33. In this configuration both left and right speaker drivers should be enabled (SPKOUTL_ENA=1 and SPKOUTR_ENA=1), but path selection and volume controls are available on left channel only (SPKMIXL, SPKLVOL and SPKOUTLBOOST).

Note that the minimum speaker load resistance and the maximum power output has a dependency on the SPKMODE output configuration, and also on the Class D/AB mode selection. See “Electrical Characteristics” for further details.

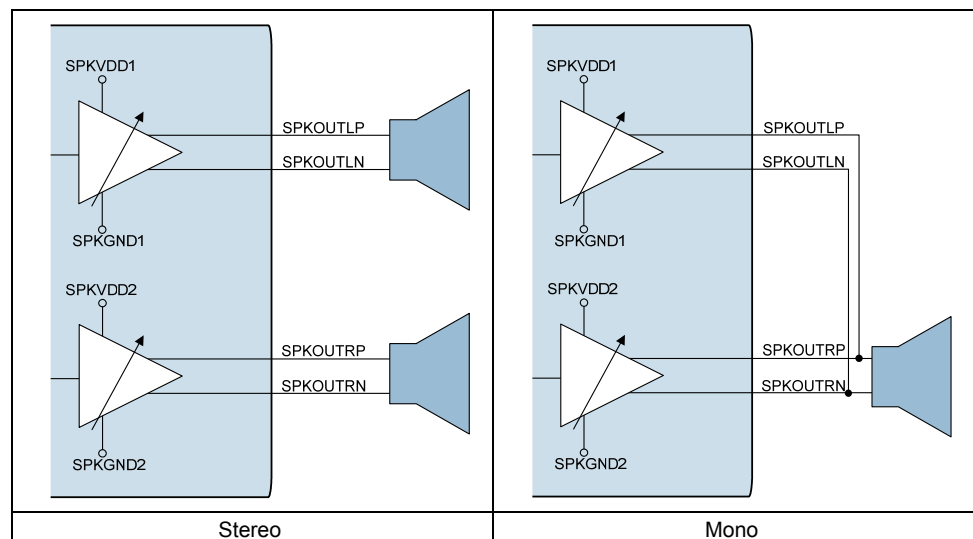

Figure 33 Stereo / Mono Speaker Output Configurations

Eight levels of AC signal boost are provided in order to deliver maximum output power for many commonly-used SPKVDD/AVDD1 combinations. (Note that SPKVDD1 powers the Left Speaker driver, and SPKVDD2 powers the Right Speaker driver; it is assumed that SPKVDD1 = SPKVDD2 = SPKVDD.)

The signal boost options are available in both Class AB and Class D modes. The AC boost levels from 0dB to +12dB are selected using register bits SPKOUTL_BOOST and SPKOUTR_BOOST. To prevent pop noise, SPKOUTL_BOOST and SPKOUTR_BOOST should not be modified while the speaker outputs are enabled. Figure 34 illustrates the speaker outputs and the mixing and gain/boost options available.

Ultra-low leakage and high PSRR allow the speaker supply SPKVDD to be directly connected to a lithium battery. Note that an appropriate SPKVDD supply voltage must be provided to prevent waveform clipping when speaker boost is used.

DC gain is applied automatically in both Class AB and Class D modes with a shift from VMID to SPKVDD/2. This provides optimum signal swing for maximum output power. In Class AB mode, an ultra-high PSRR mode is available, in which the DC reference for the speaker driver is fixed at VMID. This mode is selected by enabling the SPKAB_REF_SEL bit (see Table 80). In this mode, the output power is limited but the driver will still be capable of driving more than 500mW in 8Ω while maintaining excellent suppression of noise on SPKVDD (for example, TDMA noise in a GSM phone application).

The AC and DC gain functions are illustrated in Figure 34.

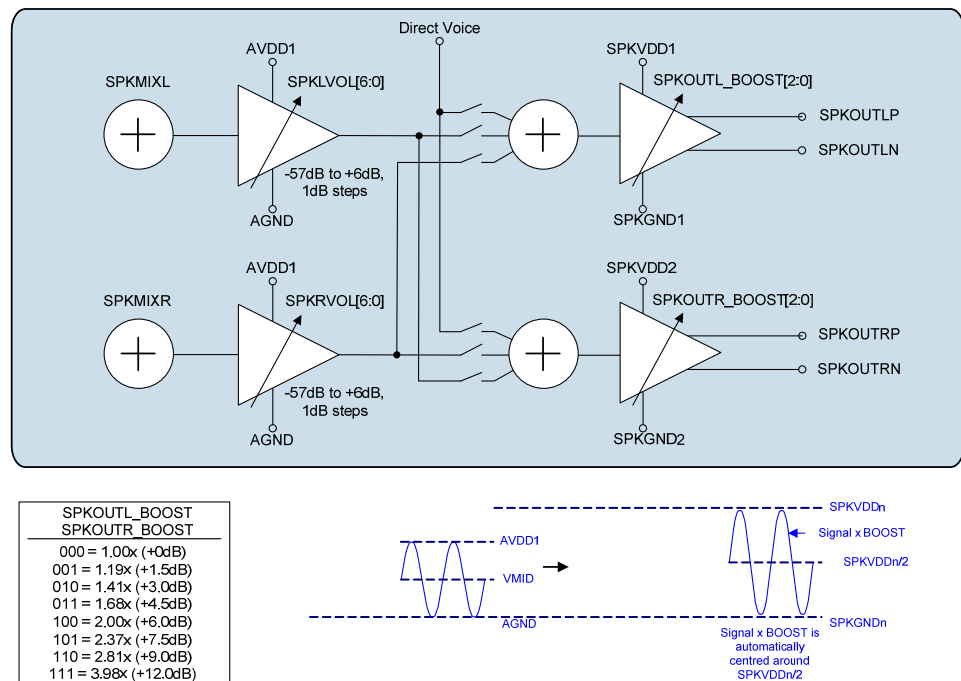

Figure 34 Speaker Output Configuration and AC Boost Operation

REGISTER ADDRESS	BIT	LABEL	DEFAULT	DESCRIPTION
R35 (0023h) SPKMIXR Attenuation	8	SPKOUT_CLASSAB	0	Speaker Class AB Mode Enable 0 = Class D mode 1 = Class AB mode
R37 (0025h) ClassD	5:3	SPKOUTL_BOOST [2:0]	000 (1.0x)	Left Speaker Gain Boost 000 = 1.00x boost (+0dB) 001 = 1.19x boost (+1.5dB) 010 = 1.41x boost (+3.0dB) 011 = 1.68x boost (+4.5dB) 100 = 2.00x boost (+6.0dB) 101 = 2.37x boost (+7.5dB) 110 = 2.81x boost (+9.0dB) 111 = 3.98x boost (+12.0dB)
	2:0	SPKOUTR_BOOST [2:0]	000 (1.0x)	Right Speaker Gain Boost 000 = 1.00x boost (+0dB) 001 = 1.19x boost (+1.5dB) 010 = 1.41x boost (+3.0dB) 011 = 1.68x boost (+4.5dB) 100 = 2.00x boost (+6.0dB) 101 = 2.37x boost (+7.5dB) 110 = 2.81x boost (+9.0dB) 111 = 3.98x boost (+12.0dB)
R34 (0022h) SPKMIXL Attenuation	8	SPKAB_REF_SEL	0	Selects Reference for Speaker in Class AB mode 0 = SPKVDD/2 1 = VMID
R1825 (0721h) Pull Control (2)	1	SPKMODE_PU	1	SPKMODE Pull-up enable 0 = Disabled 1 = Enabled

Table 80 Speaker Mode and Boost Control

Clocking of the Class D output driver is derived from SYSCLK. The clocking frequency division is configured automatically, according to the AIFn_SR and AIFnCLK_RATE registers. (See “Clocking and Sample Rates” for further details of the system clocks and control registers.)

The Class D switching clock is enabled whenever SPKOUTL_ENA or SPKOUTR_ENA is set, provided also that SPKOUT_CLASSAB = 0. The frequency is as described in Table 81.

When AIF1CLK is selected as the SYSCLK source (SYSCLK_SRC = 0), then the Class D clock frequency is controlled by the AIF1_SR and AIF1CLK_RATE registers.

When AIF2CLK is selected as the SYSCLK source (SYSCLK_SRC = 1), then the Class D clock frequency is controlled by the AIF2_SR and AIF2CLK_RATE registers.

Note that the applicable clocks (SYSCLK, AIF1CLK or AIF2CLK) must be present and enabled when using the speaker outputs in Class D mode.

SAMPLE RATE (kHz)	SYSCLK RATE (AIFnCLK / fs ratio)							
	128	192	256	384	512	768	1024	1536
8	256	256	341.3	256	341.3	256	341.3	256
11.025	352.8	352.8	352.8	352.8	352.8	352.8	352.8	
12	384	384	384	384	384	384	384	
16	341.3	384	341.3	384	341.3	384		
22.05	352.8	352.8	352.8	352.8	352.8			
24	384	384	384	384	384			
32	341.3	384	341.3	384				
44.1	352.8	352.8	352.8					
48	384	384	384					
88.2	352.8							
96	384							

Table 81 Class D Switching Frequency (kHz)

HEADPHONE OUTPUT CONFIGURATIONS

The headphone outputs HPOUT1L and HPOUT1R are driven by the headphone output PGAs HPOUT1LVOL and HPOUT1RVOL. Each PGA has its own dedicated volume control, as described in the “Analogue Output Signal Path” section. The input to these PGAs can be either the output mixers MIXOUTL and MIXOUTR or the direct DAC1 outputs DAC1L and DAC1R.

The headphone output driver is capable of driving up to 30mW into a 16Ω load or 25mW into a 32Ω load such as a stereo headset or headphones. The outputs are ground-referenced, eliminating any requirement for AC coupling capacitors. This is achieved by having separate positive and negative supply rails powered by an on-chip charge pump. A DC Servo circuit removes any DC offset from the headphone outputs, suppressing ‘pop’ noise and minimising power consumption. The Charge Pump and DC Servo are described separately (see “Charge Pump” and “DC Servo” respectively).

It is recommended to connect a zobel network to the headphone output pins HPOUT1L and HPOUT1R for best audio performance in all applications. The components of the zobel network have the effect of dampening high frequency oscillations or instabilities that can arise outside the audio band under certain conditions. Possible sources of these instabilities include the inductive load of a headphone coil or an active load in the form of an external line amplifier. The capacitance of lengthy cables or PCB tracks can also lead to amplifier instability. The zobel network should comprise of a 20Ω resistor and 100nF capacitor in series with each other, as illustrated in Figure 35.

If any ground-referenced headphone output is not used, then the zobel network components can be omitted from the corresponding output pin, and the pin can be left floating. The respective headphone driver(s) should not be enabled in this case.

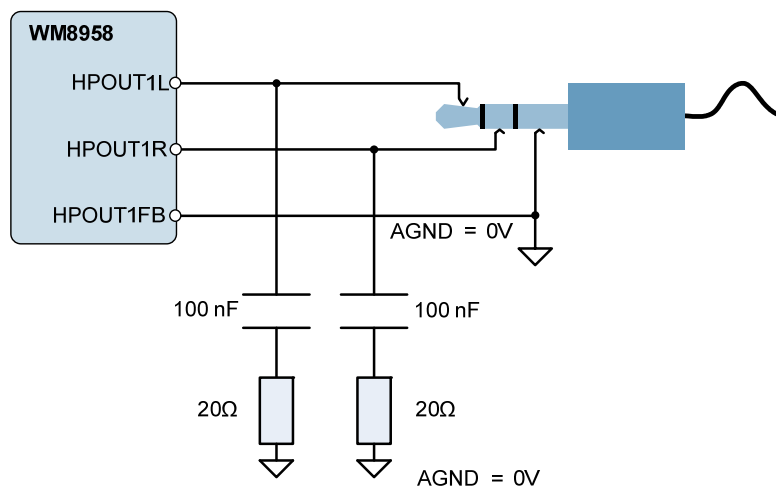

Figure 35 Zobel Network Components for HPOUT1L and HPOUT1R

The headphone output incorporates a common mode, or ground loop, feedback path which provides rejection of system-related ground noise. The return path is via HPOUT1FB. This pin must be connected to ground for normal operation of the headphone output. No register configuration is required.

Note that the HPOUT1FB pin should be connected to GND close to the headphone jack, as illustrated in Figure 35.

EARPIECE DRIVER OUTPUT CONFIGURATIONS

The earpiece driver outputs HPOUT2P and HPOUT2N are driven by the HPOUT2MIX output mixer, which can take inputs from the mixer output PGAs MIXOUTLVOL and MIXOUTRVOL, or from the low power, differential Direct Voice path IN2LP/VRXN and IN2RP/VRXP. Fine volume control is available on the output mixer paths using MIXOUTLVOL and MIXOUTRVOL. A selectable -6dB attenuation is available on the HPOUT2MIX output, as described in Table 73 (refer to the “Analogue Output Signal Path” section).

The earpiece outputs are designed to operate in a BTL configuration, driving 50mW into a typical 16Ω ear speaker.

For suppression of pop noise there are two separate enables for the earpiece driver; HPOUT2_ENA enables the output stage and HPOUT2_IN_ENA enables the mixer and input stage. HPOUT2_IN_ENA should be enabled a minimum of 50μs before HPOUT2_ENA – see “Control Write Sequencer” section for an example power sequence.

LINE OUTPUT CONFIGURATIONS

The four line outputs LINEOUT1P, LINEOUT1N, LINEOUT2P and LINEOUT2N provide a highly flexible combination of differential and single-ended configurations, each driven by a dedicated output mixer. There is a selectable -6dB gain option in each mixer to avoid clipping when mixing more than one signal into a line output. Additional volume control is available at other locations within each of the supported signal paths. For more information about the line output mixing options, refer to the “Analogue Output Signal Path” section.

Typical applications for the line outputs (single-ended or differential) are:

- Handset or headset microphone output to external voice CODEC
- Stereo line output
- Output to external speaker driver(s) to support additional loudspeakers

When single-ended mode is selected for either LINEOUT1 or LINEOUT2, a buffered VMID must be enabled as a reference for the outputs. This is enabled by setting the LINEOUT_VMID_BUF_ENA bit as defined in Table 82.

REGISTER ADDRESS	BIT	LABEL	DEFAULT	DESCRIPTION
R56 (0038h) AntiPOP (1)	7	LINEOUT_VMID_BUF_ENA	0	Enables VMID reference for line outputs in single-ended mode 0 = Disabled 1 = Enabled

Table 82 LINEOUT VMID Buffer for Single-Ended Operation

Some example line output configurations are listed and illustrated below.

- Differential line output from Mic/Line input on IN1L PGA
- Differential line output from Mic/Line input on IN1R PGA
- Stereo differential line output from output mixers MIXOUTL and MIXOUTR
- Stereo single-ended line output from output mixer to either LINEOUT1 or LINEOUT2
- Mono single-ended line output from output mixer

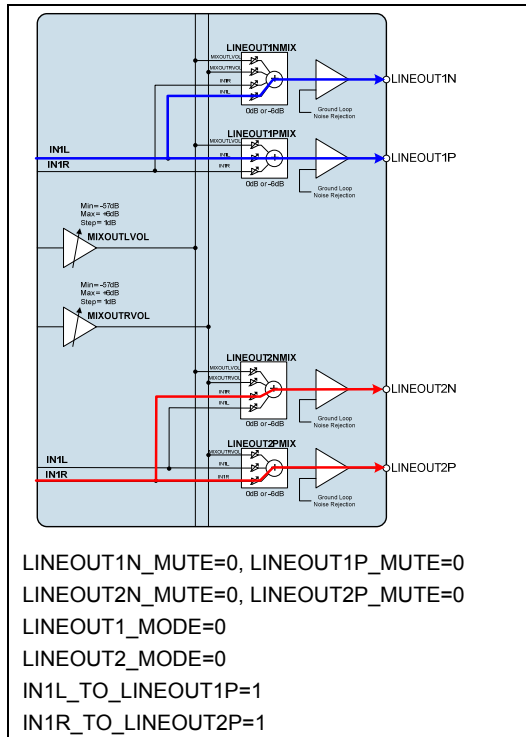

Figure 36 Differential Line Out from input PGA IN1L (to LINEOUT1) and IN1R (to LINEOUT2)

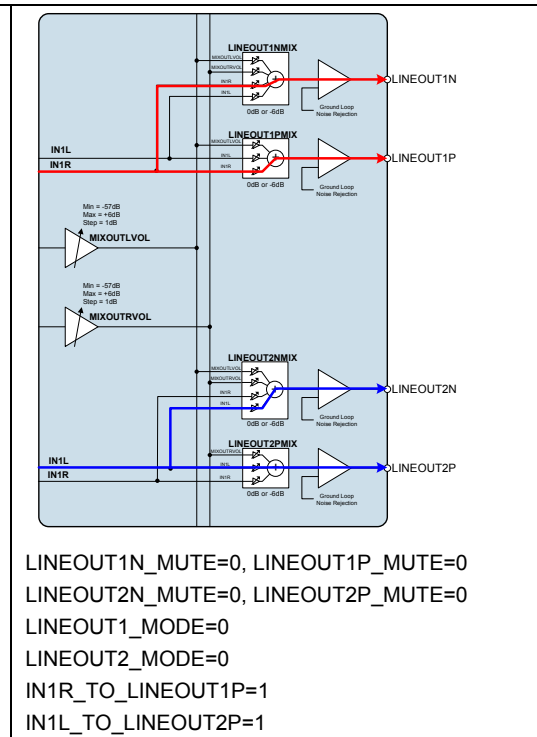

Figure 37 Differential Line Out from input PGA IN1R (to LINEOUT1) and IN1L (to LINEOUT2)

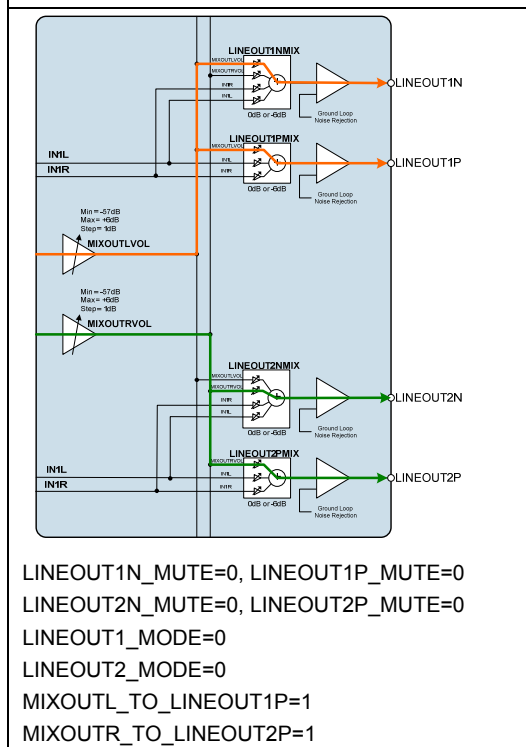

Figure 38 Stereo Differential Line Out from MIXOUTL and MIXOUTR

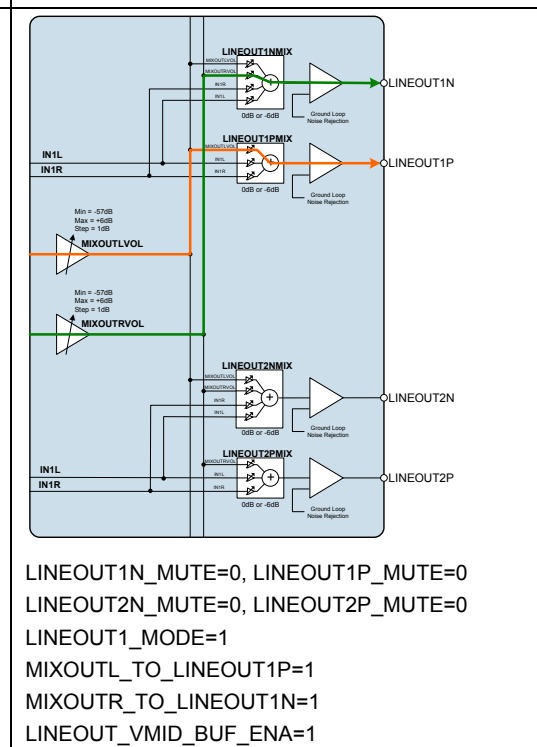
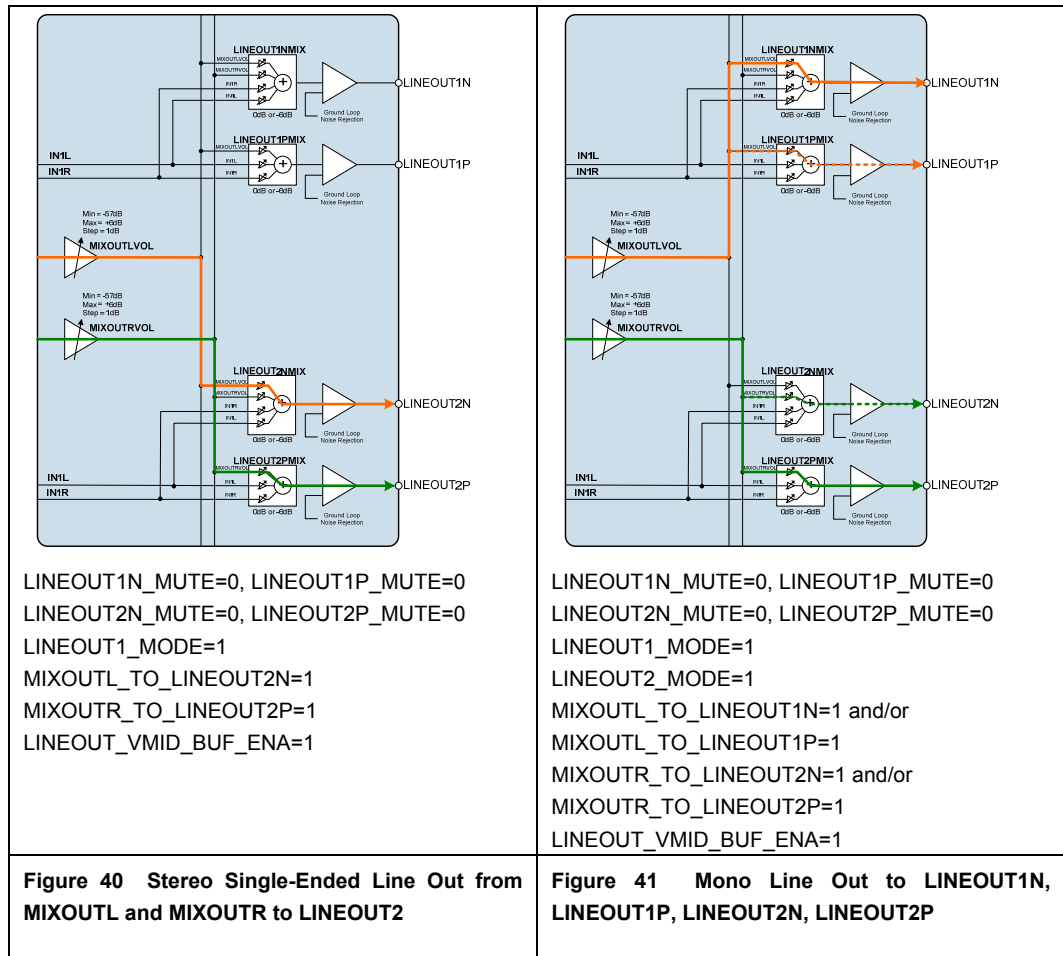

Figure 39 Stereo Single-Ended Line Out from MIXOUTL and MIXOUTR to LINEOUT1



The line outputs incorporate a common mode, or ground loop, feedback path which provides rejection of system-related ground noise. The return path, via LINEOUTFB, is enabled separately for LINEOUT1 and LINEOUT2 using the LINEOUT1_FB and LINEOUT2_FB bits as defined in Table 83.

Ground loop feedback is a benefit to single-ended line outputs only; it is not applicable to differential outputs, which already inherently offer common mode noise rejection.

REGISTER ADDRESS	BIT	LABEL	DEFAULT	DESCRIPTION
R55 (0037h) Additional Control	7	LINEOUT1_FB	0	Enable ground loop noise feedback on LINEOUT1 0 = Disabled 1 = Enabled
	6	LINEOUT2_FB	0	Enable ground loop noise feedback on LINEOUT2 0 = Disabled 1 = Enabled

Table 83 Line Output Ground Loop Feedback Enable

EXTERNAL ACCESSORY DETECTION

The WM8958 accessory detection circuit measures the impedance of an external load connected to the MICDET pin. This feature can be used to detect the insertion or removal of a microphone, and the status of the associated hookswitch. It can also be used to detect push-button status or the connection of other external accessories.

The microphone detection circuit measures the impedance connected to MICDET, and reports whether the measured impedance lies within one of 9 pre-defined levels (including the 'no accessory detected' level). This means it can detect the presence of a typical microphone and up to 7 push-buttons. One of the impedance levels is specifically designed to detect a video accessory (typical 75 Ω) load if required.

The microphone detection circuit uses the MICBIAS2 output as a reference. The WM8958 will automatically enable MICBIAS2 when required in order to perform the detection function; this allows the detection function to be supported in low-power standby operating conditions.

Microphone detection is enabled by setting the MICD_ENA register. When microphone detection is enabled, the WM8958 performs a number of measurements in order to determine the MICDET impedance. The measurement process is repeated at a cyclic rate controlled by MICD_RATE. (The MICD_RATE register selects the delay between completion of one measurement and the start of the next.)

For best accuracy, the measured impedance is only deemed valid after more than one successive measurement has produced the same result. The MICD_DBTIME register provides control of the de-bounce period; this can be either 2 measurements or 4 measurements.

When the microphone detection result has settled (ie. after the applicable de-bounce period), the WM8958 indicates valid data by setting the MICD_VALID bit. The measured impedance is indicated using the MICD_LVL and MICD_STS register bits, as described in Table 84.

The MICD_VALID bit, when set, remains asserted for as long as the microphone detection function is enabled (ie. while MICD_ENA = 1). If the detected impedance changes, then the MICD_LVL and MICD_STS fields will change, but the MICD_VALID bit will remain set, indicating valid data at all times.

Note that the impedance levels quoted in the MICD_LVL description assume that a microphone (475 Ω to 30k Ω impedance) is also present on the MICDET pin. The limits quoted in the "Electrical Characteristics" refer to the combined effective impedance on the MICDET pin. Typical external components are described in the "Applications Information" section.

The microphone detection reports a measurement result in one of the pre-defined impedance levels. Each measurement level can be enabled or disabled independently; this provides flexibility according to the required thresholds, and offers a faster measurement time in some applications. The MICD_LVL_SEL register is described in detail later in this section.

Clocking for the microphone detection function is derived from SYSCLK (defined in the "Clocking and Sample Rates" section).

When AIF1CLK is selected as the SYSCLK source (SYSCLK_SRC = 0), then AIF1CLK must be present and enabled when using the accessory detect function. The AIF1_SR and AIF1CLK_RATE registers must be set to values that are consistent with the available AIF1CLK frequency.

When AIF2CLK is selected as the SYSCLK source (SYSCLK_SRC = 1), then AIF2CLK must be present and enabled when using the accessory detect function. The AIF2_SR and AIF2CLK_RATE registers must be set to values that are consistent with the available AIF2CLK frequency.

The Frequency Locked Loop (FLL) free-running mode provides flexibility to clock the microphone detection function without any external reference clock, eg. in low-power standby operating conditions. See "Clocking and Sample Rates" for details of the WM8958 clocking options and FLL.

The accessory detection function can also be supported using a low frequency (eg. 32kHz) clock, as described later in this section, see "Accessory Detection with Low Frequency SYSCLK".

The microphone detection function is an input to the Interrupt control circuit and can be used to trigger an Interrupt event every time an accessory insertion, removal or impedance change is detected. See "Interrupts" for further details.

The microphone detection function can also generate a GPIO output, providing an external indication of the microphone detection. This GPIO output is pulsed every time an accessory insertion, removal or impedance change is detected. See “General Purpose Input/Output” for details of how to configure a GPIO pin to output the microphone detection signal.

The register fields associated with Microphone Detection (or other accessories) are described in Table 84. The external circuit configuration is illustrated in Figure 42.

REGISTER ADDRESS	BIT	LABEL	DEFAULT	DESCRIPTION
R208 (00D0h) Mic Detect 1	15:12	MICD_BIAS_STARTTIME [3:0]	0101	Mic Detect Bias Startup Delay (If MICBIAS2 is not enabled already, this field selects the delay time allowed for MICBIAS2 to startup prior to performing the MICDET function.) 0000 = 0ms (continuous) 0001 = 0.25ms 0010 = 0.5ms 0011 = 1ms 0100 = 2ms 0101 = 4ms 0110 = 8ms 0111 = 16ms 1000 = 32ms 1001 = 64ms 1010 = 128ms 1011 = 256ms 1100 to 1111 = 512ms
	11:8	MICD_RATE [3:0]	0110	Mic Detect Rate (Selects the delay between successive Mic Detect measurements.) 0000 = 0ms (continuous) 0001 = 0.25ms 0010 = 0.5ms 0011 = 1ms 0100 = 2ms 0101 = 4ms 0110 = 8ms 0111 = 16ms 1000 = 32ms 1001 = 64ms 1010 = 128ms 1011 = 256ms 1100 to 1111 = 512ms
	1	MICD_DBTIME	0	Mic Detect De-bounce 0 = 2 measurements 1 = 4 measurements
	0	MICD_ENA	0	Mic Detect Enable 0 = Disabled 1 = Enabled

REGISTER ADDRESS	BIT	LABEL	DEFAULT	DESCRIPTION
R209 (00D1h) Mic Detect 2	7:0	MICD_LVL_SEL [7:0]	0111_ 1111	Mic Detect Level Select (enables Mic Detection in specific impedance ranges) [7] = Not used - must be set to 0 [6] = Enable >475 ohm detection [5] = Enable 326 ohm detection [4] = Enable 152 ohm detection [3] = Enable 77 ohm detection [2] = Enable 47.6 ohm detection [1] = Enable 29.4 ohm detection [0] = Enable 14 ohm detection Note that the impedance values quoted assume that a microphone (475ohm-30kohm) is also present on the MICDET pin.
R210 (00D2h) Mic Detect 3	10:2	MICD_LVL [8:0]	0_0000_ 0000	Mic Detect Level (indicates the measured impedance) [8] = Not used [7] = >475 ohm, <30k ohm [6] = 326 ohm [5] = 152 ohm [4] = 77 ohm [3] = 47.6 ohm [2] = 29.4 ohm [1] = 14 ohm [0] = <3 ohm Note that the impedance values quoted assume that a microphone (475ohm-30kohm) is also present on the MICDET pin.
	1	MICD_VALID	0	Mic Detect Data Valid 0 = Not Valid 1 = Valid
	0	MICD_STS	0	Mic Detect Status 0 = No Mic Accessory present (impedance is >30k ohm) 1 = Mic Accessory is present (impedance is <30k ohm)

Table 84 Microphone Detect Control

The external connections for the Microphone Detect circuit are illustrated in Figure 42. In typical applications, it can be used to detect a microphone or button press.

The microphone detection function uses MICBIAS2 as a reference. The microphone detection function will automatically enable MICBIAS2 when required for MICDET impedance measurement.

If MICBIAS2 is not already enabled (ie. if MICB2_ENA = 0), then MICBIAS2 will be enabled for short periods of time only, every time the impedance measurement is scheduled. To allow time for the MICBIAS2 source to start-up, a time delay is applied before the measurement is performed; this is configured using the MICD_BIAS_STARTTIME register, as described in Table 84.

The MICD_BIAS_STARTTIME register should be set to 16ms or more if MICB2_RATE = 1 (pop-free start-up / shut-down). The MICD_BIAS_STARTTIME register should be set to 0.25ms or more if MICB2_RATE = 0 (fast start-up / shut-down).

If the MICBIAS2 reference is not enabled continuously (ie. if MICB2_ENA = 0), then the MICBIAS2 discharge bit (MICB2_DISCH) should be set to 0.

The MICBIAS sources are configured using the registers described in Table 1, in the “Analogue Input Signal Path” section.

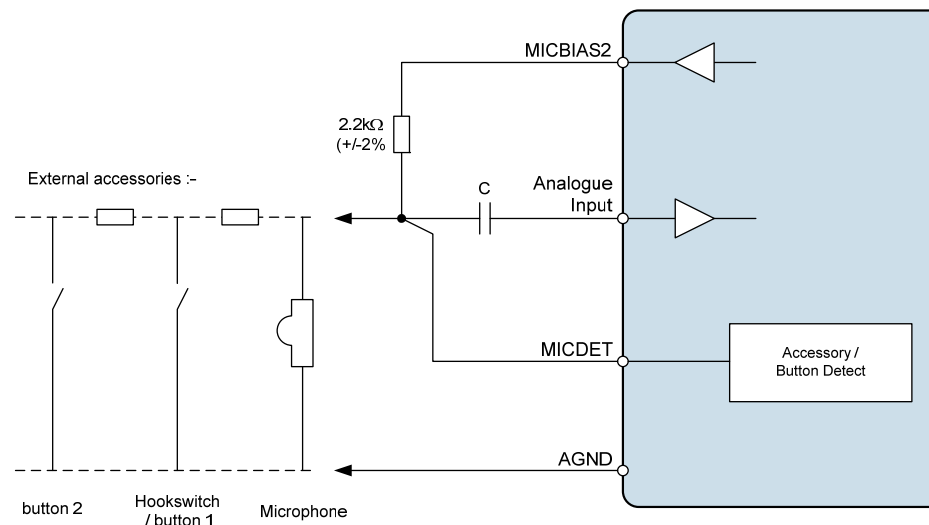

Figure 42 Microphone Detect Interface

The MICD_LVL_SEL [7:0] register bits allow each of the impedance measurement levels to be enabled or disabled independently. This allows the function to be tailored to the particular application requirements.

If one or more bits within the MICD_LVL_SEL register is set to 0, then the corresponding impedance level will be disabled. Any measured impedance which lies in a disabled level will be reported as the next lowest, enabled level.

For example, the MICD_LVL_SEL [3] bit enables the detection of impedances around 77Ω. If MICD_LVL_SEL [3] = 0, then an external impedance of 77Ω will not be indicated as 77Ω but will be indicated as 47Ω; this would be reported in the MICD_LVL register as MICD_LVL [3] = 1.

With all measurement levels enabled, the WM8958 can detect the presence of a typical microphone and up to 7 push-buttons. The microphone detect function is specifically designed to detect a video accessory (typical 75Ω) load if required.

See “Applications Information” for typical recommended external components for microphone, video or push-button accessory detection.

The microphone detection circuit assumes that a 2.2kΩ (2%) resistor is connected to MICBIAS2, as illustrated. Different resistor values will lead to inaccuracy in the impedance measurement.

The measurement accuracy of the microphone detect function is assured whenever the connected load is within the applicable limits specified in the “Electrical Characteristics”. Note that a 2.2kΩ (2%) resistor must also be connected between MICDET and MICBIAS2.

Note that the connection of a microphone will change the measured impedance on the MICDET pin; see “Applications Information” for recommended components for typical applications.

The measurement time varies between 100μs and 500μs according to the impedance of the external load. A high impedance will be measured faster than a low impedance.

The timing of the microphone detect function is illustrated in Figure 43. Two different cases are shown, according to whether MICBIAS2 is enabled periodically by the impedance measurement function (MICB2_ENA=0), or is enabled at all times (MICB2_ENA=1).

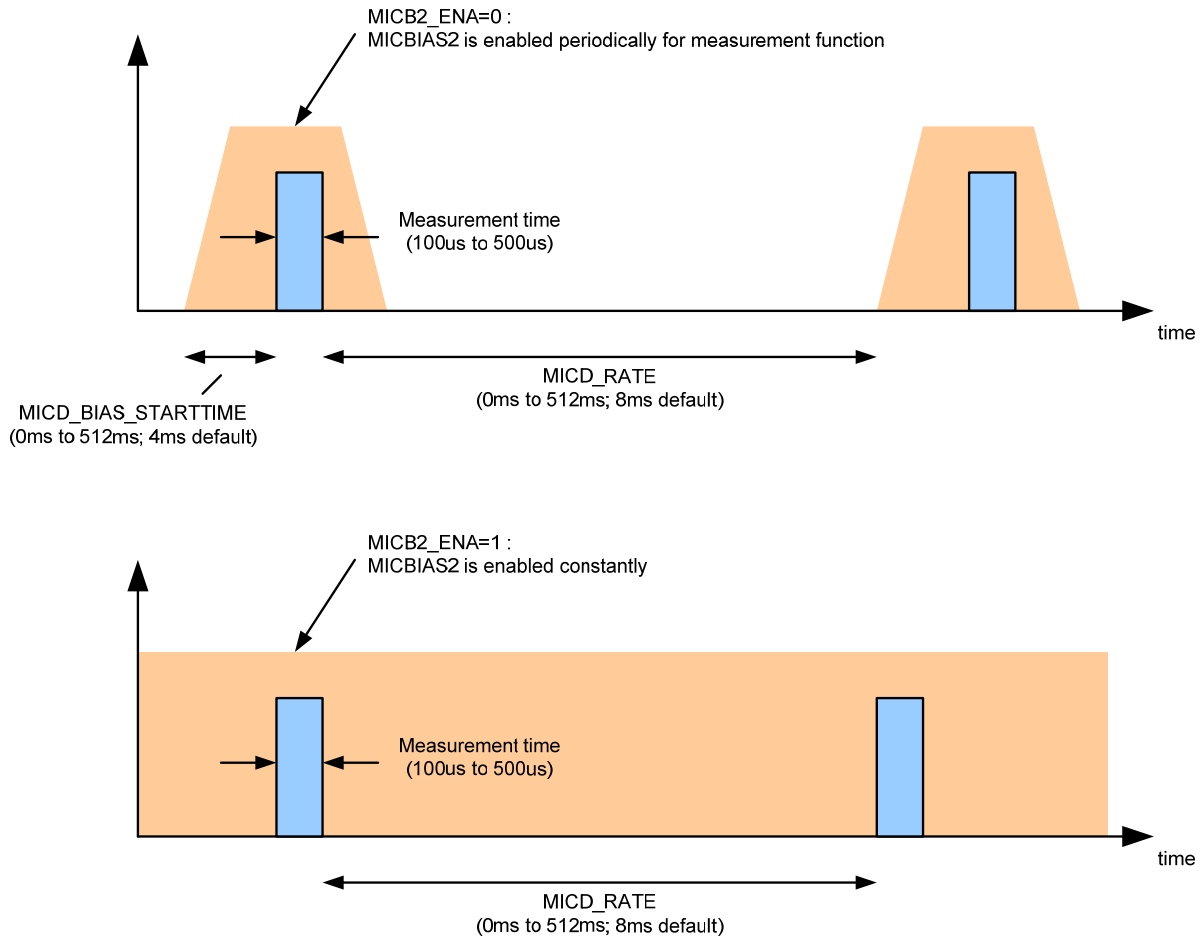

Figure 43 Microphone Detect Timing

ACCESSORY DETECTION WITH LOW FREQUENCY SYSCLK

Clocking for the microphone detection function can be derived from AIF1CLK or AIF2CLK, as described earlier.

Under normal circumstances, the AIFn_SR and AIFnCLK_RATE registers must be set to values that are consistent with the available AIFnCLK frequency. The register settings support AIFnCLK frequencies of 1.024MHz or higher.

The microphone detection function can also be supported using a low frequency (eg. 32kHz) clock. In this case, the selected SYSCLK source (AIF1CLK or AIF2CLK) should be configured with the following register settings:

- AIFnCLK_RATE = 0001 (AIFnCLK / fs = 128)
- AIFn_SR = 0000 (fs = 8kHz).

The register settings above configure the WM8958 for AIFnCLK = 1.024MHz. If the available clock is a different frequency (eg. 32kHz), then the timings set by the MICD_RATE and MICD_BIAS_STARTUP registers will be scaled accordingly. In the case of a 32kHz clock, these times will be extended by a factor of 32 (calculated as 1024000 / 32000).

For example, under normal circumstances, setting MICD_RATE = 0011 selects a 1ms delay between successive measurements. Using a 32kHz reference clock, and the register settings above, then MICD_RATE = 0011 will select a 32ms delay.

GENERAL PURPOSE INPUT/OUTPUT

The WM8958 provides a number of GPIO functions to enable interfacing and detection of external hardware and to provide logic outputs to other devices. The input functions can be polled directly or can be used to generate an Interrupt (IRQ) event. The GPIO and Interrupt circuits support the following functions:

- Alternate interface functions (AIF2, AIF3)
- Button detect (GPIO input)
- Logic '1' and logic '0' output (GPIO output)
- Interrupt (IRQ) status output
- Over-Temperature detection
- Microphone accessory status detection
- Frequency Locked Loop (FLL) Lock status output
- Sample Rate Conversion (SRC) Lock status output
- Dynamic Range Control (DRC) Signal activity detection
- Control Write Sequencer status output
- Digital Core FIFO error status output
- Clock output (SYSCLK divided by OPCLK_DIV)
- Frequency Locked Loop (FLL) Clock output

GPIO CONTROL

For each GPIO, the selected function is determined by the GPn_FN field, where n identifies the GPIO pin (1, 6, 8, 9, 10, 11). The pin direction, set by GPn_DIR, must be set according to function selected by GPn_FN.

The alternate audio interfaces AIF2 and AIF3 are both supported using GPIO pins; the applicable pin functions are selected by setting the corresponding GPn_FN register to 00h. See Table 86 for the definition of which AIF function is available on each GPIO pin.

See "Digital Audio Interface Control" for details of AIF2 and AIF3.

When a pin is configured as a GPIO input (GPn_DIR = 1), the logic level at the pin can be read from the respective GPn_LVL bit. Note that GPn_LVL is not affected by the GPn_POL bit.

A de-bounce circuit can be enabled on any GPIO input, to avoid false event triggers. This is enabled on each pin by setting the respective GPn_DB bit.

When a pin is configured as a Logic Level output (GPn_DIR = 0, GPn_FN = 01h), its level can be set to logic 0 or logic 1 using the GPn_LVL field.

When a pin is configured as an output (GPn_DIR = 0), the polarity can be inverted using the GPn_POL bit. When GPn_POL = 1, then the selected output function is inverted. In the case of Logic Level output (GPn_FN = 01h), the external output will be the opposite logic level to GPn_LVL when GPn_POL = 1.

A GPIO output can be either CMOS driven or Open Drain. This is selected on each pin using the respective GPn_OP_CFG bit.

Internal pull-up and pull-down resistors may be enabled using the GPn_PU and GPn_PD fields; this allows greater flexibility to interface with different signals from other devices. (Note that if GPn_PU and GPn_PD are both set for any GPIO pin, then the pull-up and pull-down will be disabled.)

Each of the GPIO pins is an input to the Interrupt control circuit and can be used to trigger an Interrupt event. An interrupt event is triggered on the rising and falling edge of the GPIO input. The associated interrupt bit is latched once set; it can be polled at any time or used to control the IRQ signal. See "Interrupts" for more details of the Interrupt event handling.

The register fields that control the GPIO pins are described in Table 85.

REGISTER ADDRESS	BIT	LABEL	DEFAULT	DESCRIPTION
R1792 (0700h) GPIO 1	15	GPn_DIR	1	GPIO Pin Direction 0 = Output 1 = Input
R1797 (0705h) GPIO 6	14	GPn_PU	0	GPIO Pull-Up Enable 0 = Disabled 1 = Enabled
	13	GPn_PD	1	GPIO Pull-Down Enable 0 = Disabled 1 = Enabled
R1799 (0707h) GPIO 8	10	GPn_POL	0	GPIO Polarity Select 0 = Non-inverted (Active High) 1 = Inverted (Active Low)
to	9	GPn_OP_CFG	0	GPIO Output Configuration 0 = CMOS 1 = Open Drain
R1802 (070Ah) GPIO 11	8	GPn_DB	1	GPIO Input De-bounce 0 = Disabled 1 = Enabled
	6	GPn_LVL	0	GPIO level. Write to this bit to set a GPIO output. Read from this bit to read GPIO input level. For output functions only, when GPn_POL is set, the register contains the opposite logic level to the external pin.
	4:0	GPn_FN [4:0]		GPIO Pin Function (see Table 86 for details) GP1_FN default = 0000 GP6_FN default = 0001 GP8_FN default = 0001 GP9_FN default = 0001 GP10_FN default = 0001 GP11_FN default = 0001
Note: <i>n</i> is a number (1, 6, 8, 9, 10, 11) that identifies the individual GPIO.				

Table 85 GPIO1, GPIO6, GPIO8, GPIO9, GPIO10 to GPIO11 Control

GPIO FUNCTION SELECT

The available GPIO functions are described in Table 86. The function of each GPIO is set using the GPn_FN register, where *n* identifies the GPIO pin (1, 6, 8, 9, 10, 11). Note that the respective GPn_DIR must also be set according to whether the function is an input or output.

GPn_FN	DESCRIPTION	COMMENTS
00h	GPIO1 - ADCLRCLK1 GPIO6 - ADCLRCLK2 GPIO8 - DACDAT3 GPIO9 - ADCDAT3 GPIO10 - LRCLK3 GPIO11 - BCLK3	Alternate Audio Interface connections.
01h	Button detect input / Logic level output	GPn_DIR = 0: GPIO pin logic level is set by GPn_LVL. GPn_DIR = 1: Button detect or logic level input.
02h	Reserved	

GPn_FN	DESCRIPTION	COMMENTS
03h	IRQ	Interrupt (IRQ) output 0 = IRQ not asserted 1 = IRQ asserted
04h	Temperature (Shutdown) status output	Indicates Temperature Shutdown Sensor status 0 = Temperature is below shutdown level 1 = Temperature is above shutdown level
05h	Microphone Detect	Microphone Detect (MICDET accessory) IRQ output A single 31 μ s pulse is output whenever an accessory insertion, removal or impedance change is detected.
06h	Reserved	
07h	Reserved	
08h	Reserved	
09h	FLL1 Lock	Indicates FLL1 Lock status 0 = Not locked 1 = Locked
0Ah	FLL2 Lock	Indicates FLL2 Lock status 0 = Not locked 1 = Locked
0Bh	SRC1 Lock	Indicates SRC1 Lock status 0 = Not locked 1 = Locked
0Ch	SRC2 Lock	Indicates SRC2 Lock status 0 = Not locked 1 = Locked
0Dh	AIF1 DRC1 Signal Detect	Indicates AIF1 DRC1 Signal Detect status 0 = Signal threshold not exceeded 1 = Signal threshold exceeded
0Eh	AIF1 DRC2 Signal Detect	Indicates AIF1 DRC2 Signal Detect status 0 = Signal threshold not exceeded 1 = Signal threshold exceeded
0Fh	AIF2 DRC Signal Detect	Indicates AIF2 DRC Signal Detect status 0 = Signal threshold not exceeded 1 = Signal threshold exceeded
10h	Write Sequencer Status	Indicates Write Sequencer status 0 = Write Sequencer Idle 1 = Write Sequence Busy
11h	FIFO Error	Indicates a Digital Core FIFO Error condition 0 = Normal operation 1 = FIFO Error
12h	Clock Output OPCLK	GPIO Clock derived from SYSCLK
13h	Temperature (Warning) status output	Indicates Temperature Warning Sensor status 0 = Temperature is below warning level 1 = Temperature is above warning level
14h	DC Servo Done	Indicates DC Servo status on HPOUT1L and HPOUT1R 0 = DC Servo not complete 1 = DC Servo complete
15h	FLL1 Clock Output	Clock output from FLL1
16h	FLL2 Clock Output	Clock output from FLL2
17h to 1Fh	Reserved	

Table 86 GPIO Function Select

BUTTON DETECT (GPIO INPUT)

Button detect functionality can be selected on any GPIO pin by setting the respective GPIO registers as described in "GPIO Control". The same functionality can be used to support a Jack Detect input function.

It is recommended to enable the GPIO input de-bounce feature when using GPIOs as button input or Jack Detect input.

The GPn_LVL fields may be read to determine the logic levels on a GPIO input, after the selectable de-bounce controls. Note that GPn_LVL is not affected by the GPn_POL bit.

The de-bounced GPIO signals are also inputs to the Interrupt control circuit. An interrupt event is triggered on the rising and falling edge of the GPIO input. The associated interrupt bits are latched once set; it can be polled at any time or used to control the IRQ signal. See "Interrupts" for more details of the Interrupt event handling.

LOGIC '1' AND LOGIC '0' OUTPUT (GPIO OUTPUT)

The WM8958 can be programmed to drive a logic high or logic low level on any GPIO pin by selecting the "GPIO Output" function as described in "GPIO Control". The output logic level is selected using the respective GPn_LVL bit.

Note that the polarity of the GPIO output can be inverted using the GPn_POL registers. If GPn_POL = 1, then the external output will be the opposite logic level to GPn_LVL.

INTERRUPT (IRQ) STATUS OUTPUT

The WM8958 has an Interrupt Controller which can be used to indicate when any selected Interrupt events occur. An interrupt can be generated by any of the events described throughout the GPIO function definition above. Individual interrupts may be masked in order to configure the Interrupt as required. See "Interrupts" for further details.

The Interrupt (IRQ) status may be output directly on any GPIO pin by setting the respective GPIO registers as described in "GPIO Control".

OVER-TEMPERATURE DETECTION

The WM8958 incorporates a temperature sensor which detects when the device temperature is within normal limits or if the device is approaching a hazardous temperature condition.

The Temperature status may be output directly on any GPIO pin by setting the respective GPIO registers as described in "GPIO Control". Any GPIO pin can be used to indicate either a Warning Temperature event or the Shutdown Temperature event. De-bounce can be applied to the applicable signal using the register bits described in Table 87.

The Warning Temperature and Shutdown Temperature status are inputs to the Interrupt control circuit, after the selectable de-bounce. An interrupt event may be triggered on the rising and falling edges of these signals. The associated interrupt bit is latched once set; it can be polled at any time or used to control the IRQ signal. See "Interrupts" for more details of the Interrupt event handling.

Note that the temperature sensor can be configured to automatically disable the audio outputs of the WM8958 (see "Thermal Shutdown"). In some applications, it may be preferable to manage the temperature sensor event through GPIO or Interrupt functions, allowing a host processor to implement a controlled system response to an over-temperature condition.

The temperature sensor must be enabled by setting the TSHUT_ENA register bit. When the TSHUT_OPDIS is also set, then a device over-temperature condition will cause the speaker outputs (SPKOUTL and SPKOUTR) of the WM8958 to be disabled.

REGISTER ADDRESS	BIT	LABEL	DEFAULT	DESCRIPTION
R2 (0002h) Power Management (2)	14	TSHUT_ENA	1	Thermal sensor enable 0 = Disabled 1 = Enabled
	13	TSHUT_OPDIS	1	Thermal shutdown control (Causes audio outputs to be disabled if an overtemperature occurs. The thermal sensor must also be enabled.) 0 = Disabled 1 = Enabled
R1864 (0748h) IRQ Debounce	0	TEMP_WARN_DB	0	Thermal Warning de-bounce 0 = Disabled 1 = Enabled
	0	TEMP_SHUT_T_DB	0	Thermal shutdown de-bounce 0 = Disabled 1 = Enabled

Table 87 Temperature Sensor Enable and GPIO/Interrupt Control

MICROPHONE ACCESSORY STATUS DETECTION

The WM8958 provides an impedance measurement circuit on the MICDET pin to detect the connection of a microphone or other external accessory. See “External Accessory Detection” for further details.

A logic signal from the microphone detect circuit may be output directly on any GPIO pin by setting the respective GPIO registers as described in “GPIO Control”. This logic signal is set high for a single pulse duration of 31µs whenever an accessory insertion, removal or impedance change is detected.

The microphone detection circuit is also an input to the Interrupt control circuit. An interrupt event is triggered whenever an accessory insertion, removal or impedance change is detected. The associated interrupt bit is latched once set; it can be polled at any time or used to control the IRQ signal. See “Interrupts” for more details of the Interrupt event handling.

FREQUENCY LOCKED LOOP (FLL) LOCK STATUS OUTPUT

The WM8958 maintains a flag indicating the lock status of each of FLLs, which may be used to control other events if required. See “Clocking and Sample Rates” for more details of the FLL.

The FLL Lock signals may be output directly on any GPIO pin by setting the respective GPIO registers as described in “GPIO Control”.

The FLL Lock signals are inputs to the Interrupt control circuit. An interrupt event is triggered on the rising and falling edges of the FLL Lock signals. The associated interrupt bits are latched once set; they can be polled at any time or used to control the IRQ signal. See “Interrupts” for more details of the Interrupt event handling.

SAMPLE RATE CONVERTER (SRC) LOCK STATUS OUTPUT

The WM8958 maintains a flag indicating the lock status of each of Sample Rate Converters, which may be used to control other events if required. See “Sample Rate Conversion” for more details of the Sample Rate Converters.

The SRC Lock signals may be output directly on any GPIO pin by setting the respective GPIO registers as described in “GPIO Control”.

The SRC Lock signals are inputs to the Interrupt control circuit, after the selectable de-bounce. An interrupt event is triggered on the rising and falling edges of the SRC Lock signals. The associated interrupt bits are latched once set; they can be polled at any time or used to control the IRQ signal. See “Interrupts” for more details of the Interrupt event handling.

DYNAMIC RANGE CONTROL (DRC) SIGNAL ACTIVITY DETECTION

Signal activity detection is provided on each of the Dynamic Range Controllers (DRCs). These may be configured to indicate when a signal is present on the respective signal path. The signal activity status signals may be used to control other events if required. See “Digital Core Architecture” for more details of the DRCs and the available digital signal paths.

When a DRC is enabled, as described in “Dynamic Range Control (DRC)”, then signal activity detection can be enabled by setting the respective *[DRC]_SIG_DET* register bit. The applicable threshold can be defined either as a Peak level (Crest Factor) or an RMS level, depending on the *[DRC]_SIG_DET_MODE* register bit. When Peak level is selected, the threshold is determined by *[DRC]_SIG_DET_PK*, which defines the applicable Crest Factor (Peak to RMS ratio) threshold. If RMS level is selected, then the threshold is set using *[DRC]_SIG_DET_RMS*. These register fields are set independently for each of the three Dynamic Range Controllers, as described in Table 88.

When the DRC is enabled in any of the ADC (digital record) paths, the associated High Pass Filter (HPF) must be enabled also; this ensures that DC offsets are removed prior to the DRC processing. The output path HPF control registers are described in Table 41 (for AIF1 output paths) and Table 49 (for AIF2 output paths). These are described in the “Digital Volume and Filter Control” section.

The DRC Signal Detect signals may be output directly on any GPIO pin by setting the respective GPIO registers as described in “GPIO Control”.

The DRC Signal Detect signals are inputs to the Interrupt control circuit. An interrupt event is triggered on the rising edge of the DRC Signal Detect signals. The associated interrupt bits are latched once set; they can be polled at any time or used to control the IRQ signal. See “Interrupts” for more details of the Interrupt event handling.

REGISTER ADDRESS	BIT	LABEL	DEFAULT	DESCRIPTION
R1088 (0440h) AIF1 DRC1 (1)	15:11	AIF1DRC1_SIG_DET_RMS [4:0]	00000	AIF1 DRC1 Signal Detect RMS Threshold. This is the RMS signal level for signal detect to be indicated when AIF1DRC1_SIG_DET_MODE=1. 00000 = -30dB 00001 = -31.5dB (1.5dB steps) 11110 = -75dB 11111 = -76.5dB
	10:9	AIF1DRC1_SIG_DET_PK [1:0]	00	AIF1 DRC1 Signal Detect Peak Threshold. This is the Peak/RMS ratio, or Crest Factor, level for signal detect to be indicated when AIF1DRC1_SIG_DET_MODE=0. 00 = 12dB 01 = 18dB 10 = 24dB 11 = 30dB
	7	AIF1DRC1_SIG_DET_MODE	1	AIF1 DRC1 Signal Detect Mode 0 = Peak threshold mode 1 = RMS threshold mode
	6	AIF1DRC1_SIG_DET	0	AIF1 DRC1 Signal Detect Enable 0 = Disabled 1 = Enabled

REGISTER ADDRESS	BIT	LABEL	DEFAULT	DESCRIPTION
R1104 (0450h) AIF1 DRC2 (1)	15:11	AIF1DRC2_SIG_DET_RMS [4:0]	00000	AIF1 DRC2 Signal Detect RMS Threshold. This is the RMS signal level for signal detect to be indicated when AIF1DRC2_SIG_DET_MODE=1. 00000 = -30dB 00001 = -31.5dB (1.5dB steps) 11110 = -75dB 11111 = -76.5dB
	10:9	AIF1DRC2_SIG_DET_PK [1:0]	00	AIF1 DRC2 Signal Detect Peak Threshold. This is the Peak/RMS ratio, or Crest Factor, level for signal detect to be indicated when AIF1DRC2_SIG_DET_MODE=0. 00 = 12dB 01 = 18dB 10 = 24dB 11 = 30dB
	7	AIF1DRC2_SIG_DET_MODE	1	AIF1 DRC2 Signal Detect Mode 0 = Peak threshold mode 1 = RMS threshold mode
	6	AIF1DRC2_SIG_DET	0	AIF1 DRC2 Signal Detect Enable 0 = Disabled 1 = Enabled
R1344 (0540h) AIF2 DRC (1)	15:11	AIF2DRC_SIG_DET_RMS [4:0]	00000	AIF2 DRC Signal Detect RMS Threshold. This is the RMS signal level for signal detect to be indicated when AIF2DRC_SIG_DET_MODE=1. 00000 = -30dB 00001 = -31.5dB (1.5dB steps) 11110 = -75dB 11111 = -76.5dB
	10:9	AIF2DRC_SIG_DET_PK [1:0]	00	AIF2 DRC Signal Detect Peak Threshold. This is the Peak/RMS ratio, or Crest Factor, level for signal detect to be indicated when AIF2DRC_SIG_DET_MODE=0. 00 = 12dB 01 = 18dB 10 = 24dB 11 = 30dB
	7	AIF2DRC_SIG_DET_MODE	1	AIF2 DRC Signal Detect Mode 0 = Peak threshold mode 1 = RMS threshold mode
	6	AIF2DRC_SIG_DET	0	AIF2 DRC Signal Detect Enable 0 = Disabled 1 = Enabled

Table 88 DRC Signal Activity Detect GPIO/Interrupt Control

CONTROL WRITE SEQUENCER STATUS DETECTION

The WM8958 Control Write Sequencer (WSEQ) can be used to execute a sequence of register write operations in response to a simple trigger event. When the Control Write Sequencer is executing a sequence, normal access to the register map via the Control Interface is restricted. See “Control Write Sequencer” for details of the Control Write Sequencer.

The WM8958 generates a signal indicating the status of the Control Write Sequencer, in order to signal to the host processor whether the Control Interface functionality is restricted due to an ongoing Control Sequence. The WSEQ_DONE flag indicates that the sequencer has completed the commanded sequence.

The Write Sequencer status may be output directly on any GPIO pin by setting the respective GPIO registers as described in “GPIO Control”.

The Write Sequencer status is an input to the Interrupt control circuit. An interrupt event is triggered on completion of a Control Sequence. The associated interrupt bit is latched once set; it can be polled at any time or used to control the IRQ signal. See “Interrupts” for more details of the Interrupt event handling.

DIGITAL CORE FIFO ERROR STATUS DETECTION

The WM8958 monitors the Digital Core for error conditions which may occur if a clock rate mismatch is detected. Under these conditions, the digital audio may become corrupted.

The most likely cause of a Digital Core FIFO Error condition is an incorrect system clocking configuration. See “Clocking and Sample Rates” for the WM8958 system clocking requirements.

The Digital Core FIFO Error function is provided in order that the system configuration can be verified during product development.

The FIFO Error signal may be output directly on any GPIO pin by setting the respective GPIO registers as described in “GPIO Control”.

The FIFO Error signal is an input to the Interrupt control circuit. An interrupt event is triggered on the rising edge of the FIFO Error signal. The associated interrupt bit is latched once set; it can be polled at any time or used to control the IRQ signal. See “Interrupts” for more details of the Interrupt event handling.

OPCLK CLOCK OUTPUT

A clock output (OPCLK) derived from SYSCLK may be output on any GPIO pin by setting the respective GPIO registers as described in “GPIO Control”. This clock is enabled by register bit OPCLK_ENA, and its frequency is controlled by OPCLK_DIV.

See “Clocking and Sample Rates” for more details of the System Clock (SYSCLK).

REGISTER ADDRESS	BIT	LABEL	DEFAULT	DESCRIPTION
R2 (0002h) Power Management (2)	11	OPCLK_ENA	0	GPIO Clock Output (OPCLK) Enable 0 = Disabled 1 = Enabled
R521 (0209h) Clocking 1	2:0	OPCLK_DIV	000	GPIO Output Clock (OPCLK) Divider 000 = SYSCLK 001 = SYSCLK / 2 010 = SYSCLK / 3 011 = SYSCLK / 4 100 = SYSCLK / 6 101 = SYSCLK / 8 110 = SYSCLK / 12 111 = SYSCLK / 16

Table 89 OPCLK Control

FLL CLOCK OUTPUT

The FLL Clock outputs may be output directly on any GPIO pin by setting the respective GPIO registers as described in "GPIO Control".

See "Clocking and Sample Rates" for more details of the WM8958 system clocking and for details of how to enable and configure the Frequency Locked Loops.

INTERRUPTS

The Interrupt Controller has multiple inputs. These include the GPIO input pins, the FLL Lock circuits, SRC Lock circuit, Microphone activity detection, Over-temperature indication, Digital FIFO error detection and the Write Sequencer status flag. Any combination of these inputs can be used to trigger an Interrupt Request (IRQ) event.

There is an Interrupt register field associated with each of the interrupt inputs. These fields are asserted whenever a logic edge is detected on the respective input. Some inputs are triggered on rising edges only; some are triggered on both edges, as noted in Table 90. The Interrupt register fields are held in Registers R1840 and R1841. The Interrupt flags can be polled at any time from these registers, or else in response to the Interrupt Request (IRQ) output being signalled via a GPIO pin.

All of the Interrupts are edge-triggered, as noted above. Many of these are triggered on both the rising and falling edges and, therefore, the Interrupt registers cannot indicate which edge has been detected. The "Raw Status" fields in Register R1842 provide readback of the current value of selected inputs to the Interrupt Controller. Note that the logic levels of any GPIO inputs can be read using the GPN_LVL registers, as described in Table 85.

Individual mask bits can select or deselect different functions from the Interrupt controller. These are listed within the Interrupt Status Mask registers, as described in Table 90. Note that the Interrupt register fields remain valid, even when masked, but the masked interrupts will not cause the Interrupt Request (IRQ) output to be asserted.

The Interrupt Request (IRQ) output represents the logical 'OR' of all the unmasked interrupts. The Interrupt register fields are latching fields and, once they are set, they are not reset until a '1' is written to the respective register bit(s). The Interrupt Request (IRQ) output is not reset until each of the unmasked interrupts has been reset.

De-bouncing of the GPIO inputs can be enabled using the register bits described in Table 85. De-bouncing is also available on the Temperature Warning and Temperature Shutdown inputs to the Interrupt Controller, in order to avoid false detections - see Table 90 for the associated registers.

The Interrupt Request (IRQ) output can be globally masked by setting the IM_IRQ register. Under default conditions, the Interrupt Request (IRQ) is not masked.

The Interrupt Request (IRQ) flag may be output on a GPIO pin - see "General Purpose Input/Output".

The WM8958 Interrupt Controller circuit is illustrated in Figure 44. (Note that not all interrupt inputs are shown.) The associated control fields are described in Table 90.

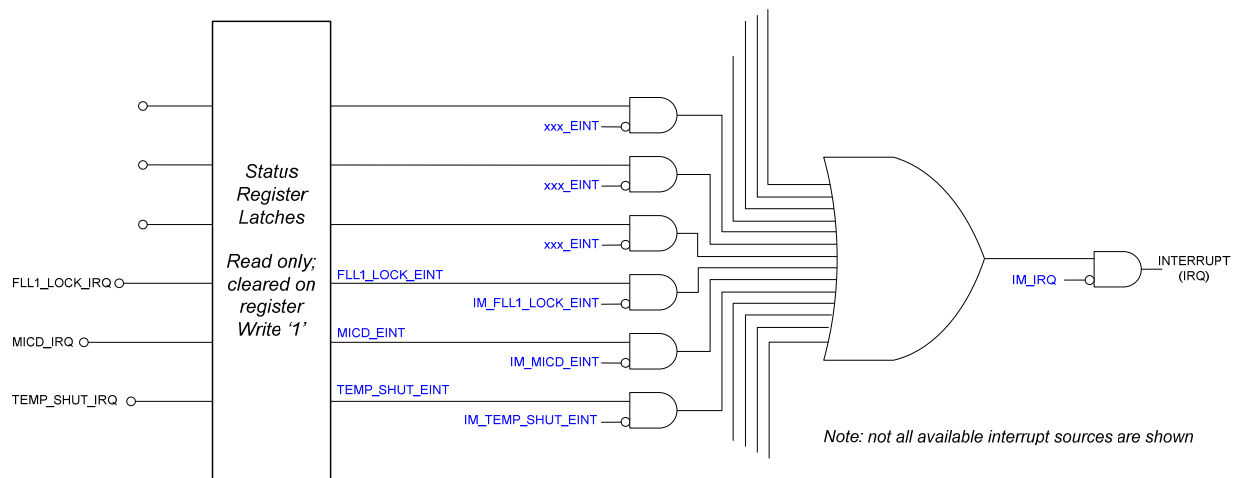

Figure 44 Interrupt Controller

REGISTER ADDRESS	BIT	LABEL	DEFAULT	DESCRIPTION
R1840 (0730h) Interrupt Status 1	10	GP11_EINT	0	GPIO11 Interrupt (Rising and falling edge triggered) Note: Cleared when a '1' is written.
	9	GP10_EINT	0	GPIO10 Interrupt (Rising and falling edge triggered) Note: Cleared when a '1' is written.
	8	GP9_EINT	0	GPIO9 Interrupt (Rising and falling edge triggered) Note: Cleared when a '1' is written.
	7	GP8_EINT	0	GPIO8 Interrupt (Rising and falling edge triggered) Note: Cleared when a '1' is written.
	5	GP6_EINT	0	GPIO6 Interrupt (Rising and falling edge triggered) Note: Cleared when a '1' is written.
	0	GP1_EINT	0	GPIO1 Interrupt (Rising and falling edge triggered) Note: Cleared when a '1' is written.
R1841 (0731h) Interrupt Status 2	15	TEMP_WARN_EINT	0	Temperature Warning Interrupt (Rising and falling edge triggered) Note: Cleared when a '1' is written.
	14	DCS_DONE_EINT	0	DC Servo Interrupt (Rising edge triggered) Note: Cleared when a '1' is written.
	13	WSEQ_DONE_EINT	0	Write Sequencer Interrupt (Rising edge triggered) Note: Cleared when a '1' is written.
	12	FIFOS_ERR_EINT	0	Digital Core FIFO Error Interrupt (Rising edge triggered) Note: Cleared when a '1' is written.
	11	AIF2DRC_SIG_DET_INTERRUPT	0	AIF2 DRC Activity Detect Interrupt (Rising edge triggered) Note: Cleared when a '1' is written.
	10	AIF1DRC2_SIG_DET_INTERRUPT	0	AIF1 DRC2 (Timeslot 1) Activity Detect Interrupt (Rising edge triggered) Note: Cleared when a '1' is written.
	9	AIF1DRC1_SIG_DET_INTERRUPT	0	AIF1 DRC1 (Timeslot 0) Activity Detect Interrupt (Rising edge triggered) Note: Cleared when a '1' is written.
	8	SRC2_LOCK_EINT	0	SRC2 Lock Interrupt (Rising and falling edge triggered) Note: Cleared when a '1' is written.
	7	SRC1_LOCK_EINT	0	SRC1 Lock Interrupt (Rising and falling edge triggered) Note: Cleared when a '1' is written.
	6	FLL2_LOCK_EINT	0	FLL2 Lock Interrupt (Rising and falling edge triggered) Note: Cleared when a '1' is written.
5	FLL1_LOCK_EINT	0	FLL1 Lock Interrupt (Rising and falling edge triggered) Note: Cleared when a '1' is written.	

REGISTER ADDRESS	BIT	LABEL	DEFAULT	DESCRIPTION
	1	MICD_EINT	0	Microphone Detection Interrupt (Rising edge triggered) Note: Cleared when a '1' is written.
	0	TEMP_SHUT_EINT	0	Temperature Shutdown Interrupt (Rising and falling edge triggered) Note: Cleared when a '1' is written.
R1842 (0732h) Interrupt Raw Status 2	15	TEMP_WARN_STS	0	Temperature Warning status 0 = Temperature is below warning level 1 = Temperature is above warning level
	14	DCS_DONE_STS	0	DC Servo status 0 = DC Servo not complete 1 = DC Servo complete
	13	WSEQ_DONE_STS	0	Write Sequencer status 0 = Sequencer Busy (sequence in progress) 1 = Sequencer Idle
	12	FIFOS_ERR_STS	0	Digital Core FIFO Error status 0 = Normal operation 1 = FIFO Error
	11	AIF2DRC_SIG_DETECT_STS	0	AIF2 DRC Signal Detect status 0 = Signal threshold not exceeded 1 = Signal threshold exceeded
	10	AIF1DRC2_SIG_DETECT_STS	0	AIF1 DRC2 (Timeslot 1) Signal Detect status 0 = Signal threshold not exceeded 1 = Signal threshold exceeded
	9	AIF1DRC1_SIG_DETECT_STS	0	AIF1 DRC1 (Timeslot 0) Signal Detect status 0 = Signal threshold not exceeded 1 = Signal threshold exceeded
	8	SRC2_LOCK_STS	0	SRC2 Lock status 0 = Not locked 1 = Locked
	7	SRC1_LOCK_STS	0	SRC1 Lock status 0 = Not locked 1 = Locked
	6	FLL2_LOCK_STS	0	FLL2 Lock status 0 = Not locked 1 = Locked
	5	FLL1_LOCK_STS	0	FLL1 Lock status 0 = Not locked 1 = Locked
	0	TEMP_SHUT_STS	0	Temperature Shutdown status 0 = Temperature is below shutdown level 1 = Temperature is above shutdown level
R1848 (0738h) Interrupt Status 1 Mask	10	IM_GP11_INTERRUPT	1	GPIO11 Interrupt mask. 0 = Do not mask interrupt. 1 = Mask interrupt.
	9	IM_GP10_INTERRUPT	1	GPIO10 Interrupt mask. 0 = Do not mask interrupt. 1 = Mask interrupt.
	8	IM_GP9_INTERRUPT	1	GPIO9 Interrupt mask. 0 = Do not mask interrupt. 1 = Mask interrupt.

REGISTER ADDRESS	BIT	LABEL	DEFAULT	DESCRIPTION
	7	IM_GP8_EINT	1	GPIO8 Interrupt mask. 0 = Do not mask interrupt. 1 = Mask interrupt.
	5	IM_GP6_EINT	1	GPIO6 Interrupt mask. 0 = Do not mask interrupt. 1 = Mask interrupt.
	0	IM_GP1_EINT	1	GPIO1 Interrupt mask. 0 = Do not mask interrupt. 1 = Mask interrupt.
R1849 (0739h) Interrupt Status 2 Mask	15	IM_TEMP_WARN_EINT	1	Temperature Warning Interrupt mask. 0 = Do not mask interrupt. 1 = Mask interrupt.
	14	IM_DCS_DONE_EINT	1	DC Servo Interrupt mask. 0 = Do not mask interrupt. 1 = Mask interrupt.
	13	IM_WSEQ_DONE_EINT	1	Write Sequencer Interrupt mask. 0 = Do not mask interrupt. 1 = Mask interrupt.
	12	IM_FIFOS_ERR_EINT	1	Digital Core FIFO Error Interrupt mask. 0 = Do not mask interrupt. 1 = Mask interrupt.
	11	IM_AIF2DR_C_SIG_DET_EINT	1	AIF2 DRC Activity Detect Interrupt mask. 0 = Do not mask interrupt. 1 = Mask interrupt.
	10	IM_AIF1DR_C2_SIG_DET_EINT	1	AIF1 DRC2 (Timeslot 1) Activity Detect Interrupt mask. 0 = Do not mask interrupt. 1 = Mask interrupt.
	9	IM_AIF1DR_C1_SIG_DET_EINT	1	AIF1 DRC1 (Timeslot 0) Activity Detect Interrupt mask. 0 = Do not mask interrupt. 1 = Mask interrupt.
	8	IM_SRC2_LOCK_EINT	1	SRC2 Lock Interrupt mask. 0 = Do not mask interrupt. 1 = Mask interrupt.
	7	IM_SRC1_LOCK_EINT	1	SRC1 Lock Interrupt mask. 0 = Do not mask interrupt. 1 = Mask interrupt.
	6	IM_FLL2_LOCK_EINT	1	FLL2 Lock Interrupt mask. 0 = Do not mask interrupt. 1 = Mask interrupt.
	5	IM_FLL1_LOCK_EINT	1	FLL1 Lock Interrupt mask. 0 = Do not mask interrupt. 1 = Mask interrupt.
		1	IM_MICD_EINT	1
	0	IM_TEMP_SHUT_EINT	1	Temperature Shutdown Interrupt mask. 0 = Do not mask interrupt. 1 = Mask interrupt.
R1856 (0740h) Interrupt Control	0	IM_IRQ	0	IRQ Output Interrupt mask. 0 = Do not mask interrupt. 1 = Mask interrupt.

REGISTER ADDRESS	BIT	LABEL	DEFAULT	DESCRIPTION
R1864 (0748h) IRQ Debounce	5	TEMP_WAR N_DB	1	Temperature Warning de-bounce 0 = Disabled 1 = Enabled
	0	TEMP_SHU T_DB	1	Temperature Shutdown de-bounce 0 = Disabled 1 = Enabled

Table 90 Interrupt Configuration

DIGITAL AUDIO INTERFACE

The WM8958 provides digital audio interfaces for inputting DAC data and outputting ADC or Digital Microphone data. Flexible routing options also allow digital audio to be switched or mixed between interfaces without involving any DAC or ADC.

The WM8958 provides two full audio interfaces, AIF1 and AIF2. A third interface, AIF3, supports Mono PCM digital audio paths to/from the AIF2 DSP functions. AIF3 can also be configured using multiplexers to provide alternate connections to AIF1 or AIF2.

The digital audio interfaces provide flexible connectivity with multiple processors (eg. Applications processor, Baseband processor and Wireless transceiver). A typical configuration is illustrated in Figure 45.

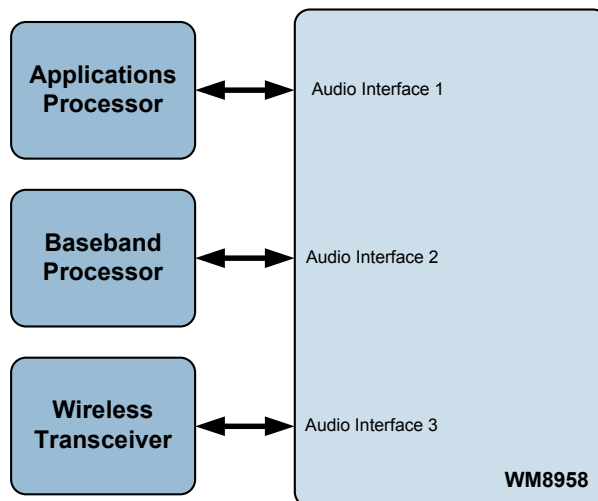

Figure 45 Typical AIF Connections

In the general case, the digital audio interface uses four pins:

- ADCDAT: ADC data output
- DACDAT: DAC data input
- LRCLK: Left/Right data alignment clock
- BCLK: Bit clock, for synchronisation

In master interface mode, the clock signals BCLK and LRCLK are outputs from the WM8958. In slave mode, these signals are inputs, as illustrated below.

As an option, a GPIO pin can be configured as the Left/Right clock for the ADC. In this case, the LRCLK pin is dedicated to the DAC, allowing the ADC and DAC to be clocked independently.

Four different audio data formats are supported each digital audio interface:

- Left justified
- Right justified
- I²S
- DSP mode

All four of these modes are MSB first. They are described in the following sections. Refer to the "Signal Timing Requirements" section for timing information.

Time Division Multiplexing (TDM) is available in all four data format modes. On AIF1, the WM8958 can transmit and receive data on two stereo pairs of timeslots simultaneously. On AIF2, the applicable timeslot pair is selectable using register control bits.

Two variants of DSP mode are supported - 'Mode A' and 'Mode B'. Mono operation can be selected on either audio interface in both DSP modes. PCM operation is supported using the DSP mode.

MASTER AND SLAVE MODE OPERATION

The WM8958 digital audio interfaces can operate as a master or slave as shown in Figure 46 and Figure 47. The associated control bits are described in "Digital Audio Interface Control".

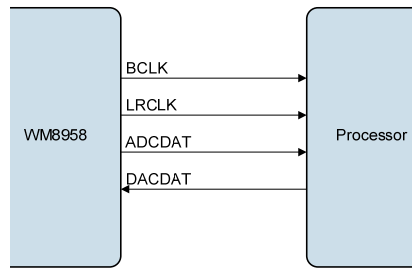

Figure 46 Master Mode

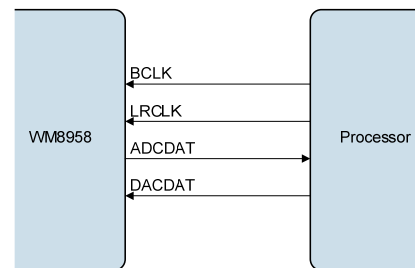

Figure 47 Slave Mode

OPERATION WITH TDM

Time division multiplexing (TDM) allows multiple devices to transfer data simultaneously on the same bus. The WM8958 ADCs and DACs support TDM in master and slave modes for all data formats and word lengths. TDM is enabled and configured using register bits defined in the "Digital Audio Interface Control" section.

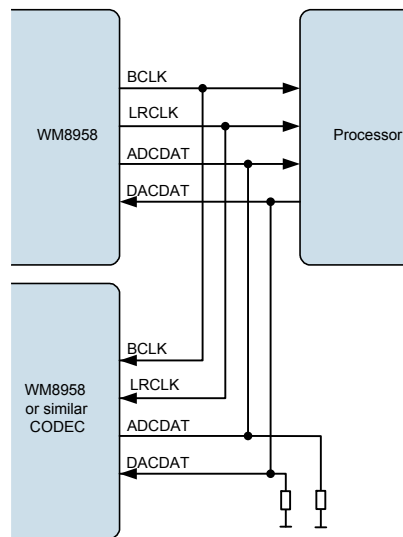

Figure 48 TDM with WM8958 as Master

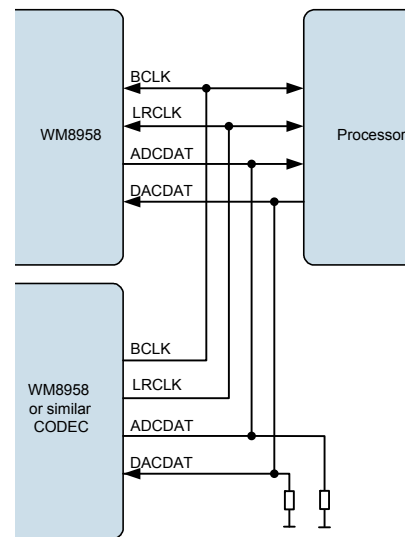

Figure 49 TDM with Other CODEC as Master

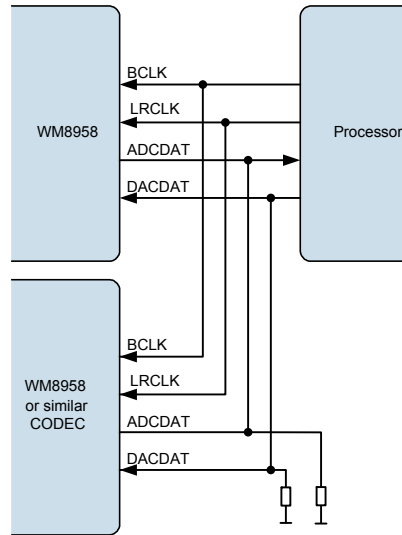

Figure 50 TDM with Processor as Master

Note: The WM8958 is a 24-bit device. If the user operates the WM8958 in 32-bit mode then the 8 LSBs will be ignored on the receiving side and not driven on the transmitting side. It is therefore recommended to add a pull-down resistor if necessary to the DACDAT line and the ADCDAT line in TDM mode.

AUDIO DATA FORMATS (NORMAL MODE)

The audio data modes supported by the WM8958 are described below. Note that the polarity of the BCLK and LRCLK signals can be inverted if required; the following descriptions all assume the default, non-inverted polarity of these signals.

In Right Justified mode, the LSB is available on the last rising edge of BCLK before a LRCLK transition. All other bits are transmitted before (MSB first). Depending on word length, BCLK frequency and sample rate, there may be unused BCLK cycles after each LRCLK transition.

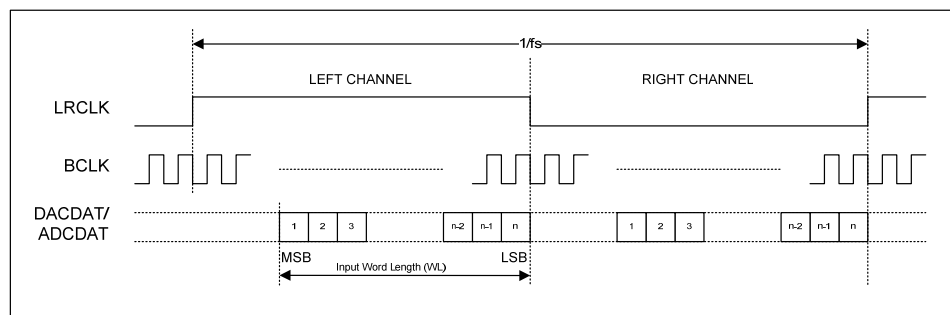

Figure 51 Right Justified Audio Interface (assuming n-bit word length)

In Left Justified mode, the MSB is available on the first rising edge of BCLK following a LRCLK transition. The other bits up to the LSB are then transmitted in order. Depending on word length, BCLK frequency and sample rate, there may be unused BCLK cycles before each LRCLK transition.

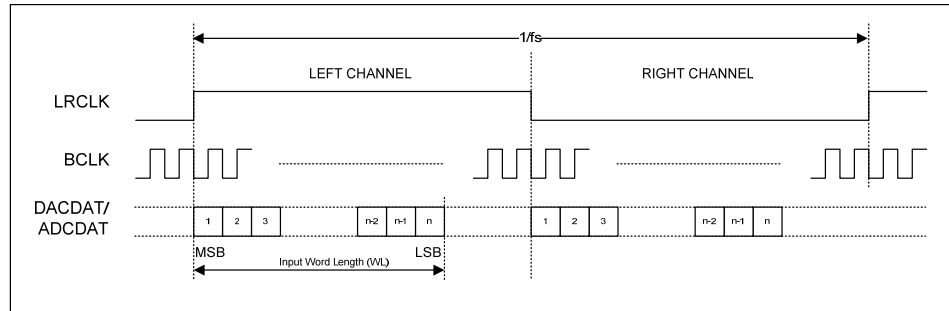

Figure 52 Left Justified Audio Interface (assuming n-bit word length)

In I²S mode, the MSB is available on the second rising edge of BCLK following a LRCLK transition. The other bits up to the LSB are then transmitted in order. Depending on word length, BCLK frequency and sample rate, there may be unused BCLK cycles between the LSB of one sample and the MSB of the next.

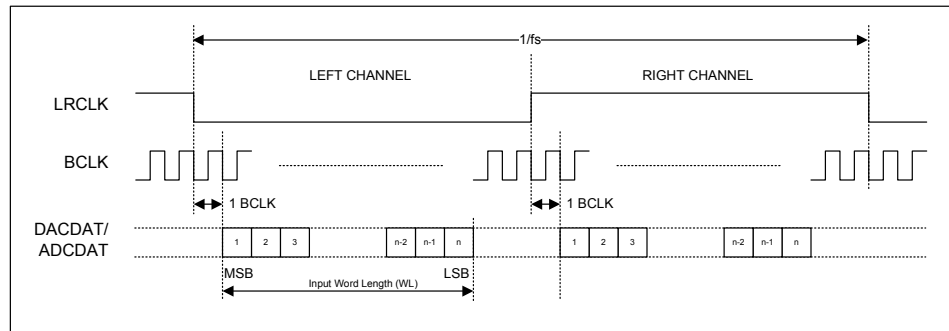

Figure 53 I2S Justified Audio Interface (assuming n-bit word length)

In DSP mode, the left channel MSB is available on either the 1st (mode B) or 2nd (mode A) rising edge of BCLK following a rising edge of LRCLK. Right channel data immediately follows left channel data. Depending on word length, BCLK frequency and sample rate, there may be unused BCLK cycles between the LSB of the right channel data and the next sample.

The selected mode (Mode A or Mode B) is determined by the AIFnDAC_LRCLK_INV bits for the AIFn digital input (playback) signal paths, and by the AIFnADC_LRCLK_INV bits for the AIFn digital output (record) signal paths.

Note that the DSP Mode is selected independently for the input/output paths of each digital audio interface.

In device master mode, the LRCLK output will resemble the frame pulse shown in Figure 54 and Figure 55. In device slave mode, Figure 56 and Figure 57, it is possible to use any length of frame pulse less than 1/fs, providing the falling edge of the frame pulse occurs greater than one BCLK period before the rising edge of the next frame pulse.

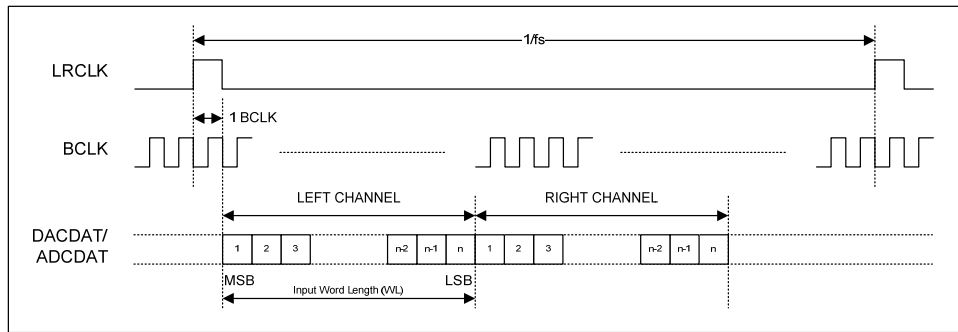

Figure 54 DSP Mode A (AIFnDAC_LRCLK_INV / AIFnADC_LRCLK_INV=0, Master)

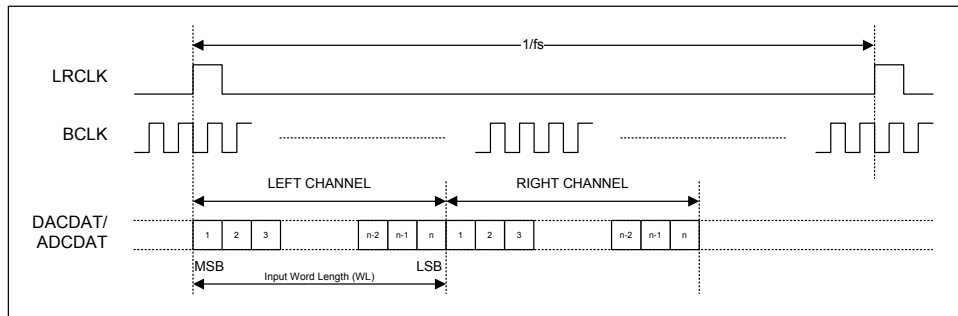

Figure 55 DSP B Mode (AIFnDAC_LRCLK_INV / AIFnADC_LRCLK_INV=1, Master)

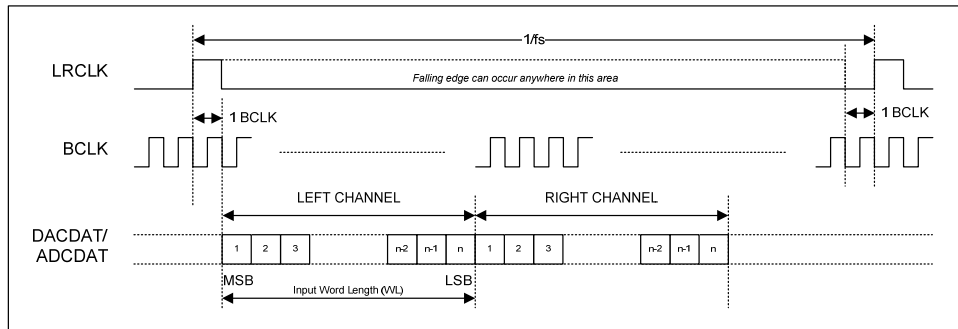

Figure 56 DSP Mode A (AIFnDAC_LRCLK_INV / AIFnADC_LRCLK_INV =0, Slave)

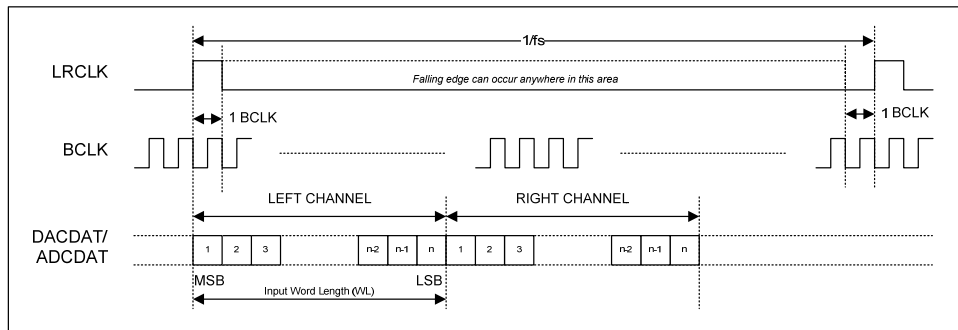

Figure 57 DSP Mode B (AIFnDAC_LRCLK_INV / AIFnADC_LRCLK_INV =1, Slave)

Mono mode operation is available in DSP interface mode. When Mono mode is enabled, the audio data is transmitted or received starting on either the 1st (mode B) or 2nd (mode A) rising edge of BCLK following a rising edge of LRCLK.

PCM operation is supported in DSP interface mode. WM8958 ADC data that is output on the Left Channel will be read as mono PCM data by the receiving equipment. Mono PCM data received by the WM8958 will be treated as Left Channel data. This data may be routed to the Left/Right DACs using the control fields described in the “Digital Mixing” and “Digital Audio Interface Control” sections.

AUDIO DATA FORMATS (TDM MODE)

TDM is supported in master and slave modes. All audio interface data formats support time division multiplexing (TDM) for ADC and DAC data.

When more than one pair of ADC or DAC data channels is enabled on AIF1, the WM8958 will transmit and receive data in both Slot 0 and Slot 1.

In the case of AIF2, the ADC or DAC data can be transmitted or received in either timeslot; the required timeslot is selected using register control bits when TDM is enabled.

When TDM is enabled, the ADCDAT pin will be tri-stated immediately before and immediately after data transmission, to allow another ADC device to drive this signal line for the remainder of the sample period. Note that it is important that two ADC devices do not attempt to drive the data pin simultaneously. A short circuit may occur if the transmission time of the two ADC devices overlap with each other. See “Audio Interface Timing” for details of the ADCDAT output relative to BCLK signal. Note that it is possible to ensure a gap exists between transmissions by setting the transmitted word length to a value higher than the actual length of the data. For example, if 32-bit word length is selected where only 24-bit data is available, then the WM8958 interface will tri-state after transmission of the 24-bit data, ensuring a gap after the WM8958 TDM slot.

On AIF1, TDM can be used to transmit or receive up to four signal paths. Each enabled signal path is transmitted (on ADCDAT) or received (on DACDAT) sequentially. If one or more of the signal paths is disabled, then the position of remaining data blocks within the LRCLK frame may differ from those illustrated in Figure 58 to Figure 62, as the affected channel(s) will revert to the ‘normal’ (non-TDM) format. When the AIF1ADC_TDM register is set, then the ADCDAT1 output is tri-stated when not outputting data.

On AIF2, the TDM format is enabled by register control (AIF2ADC_TDM and AIF2DAC_TDM for the output and input paths respectively). When TDM is enabled on AIF2, the data formats shown in Figure 58 to Figure 62 are always selected, and the WM8958 transmits or receives data in one of the two available timeslots; the ADCDAT2 output is tri-stated when not outputting data.

In all cases, the BCLK frequency must be high enough to allow data from the relevant time slots to be transferred. The relative timing of Slot 0 and Slot 1 depends upon the selected data format; the TDM timing for four input or output channels is shown in Figure 58 to Figure 62.

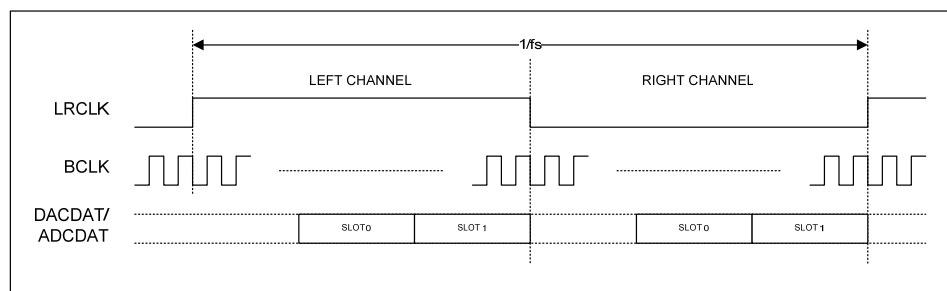

Figure 58 TDM in Right-Justified Mode

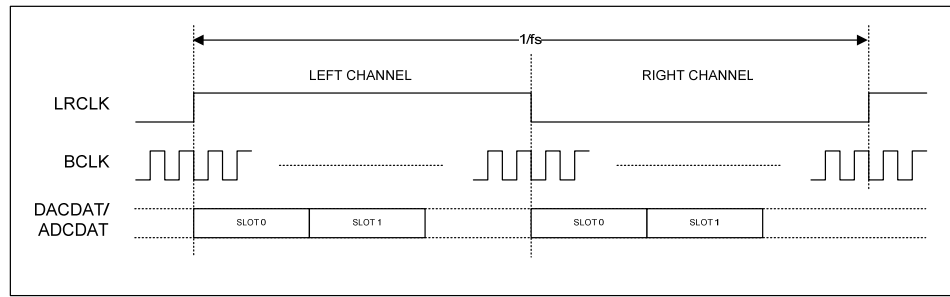

Figure 59 TDM in Left-Justified Mode

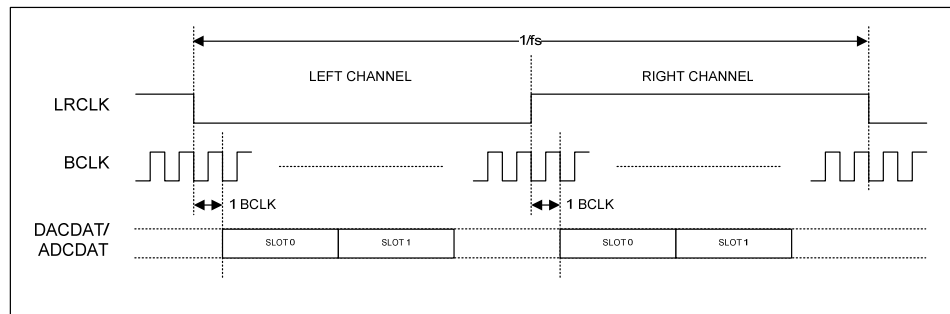

Figure 60 TDM in I²S Mode

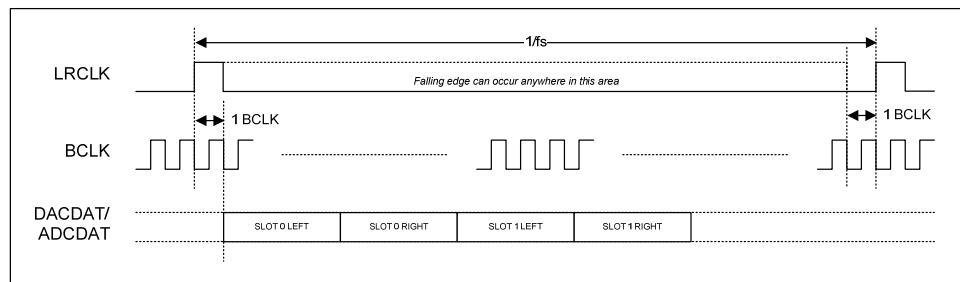

Figure 61 TDM in DSP Mode A

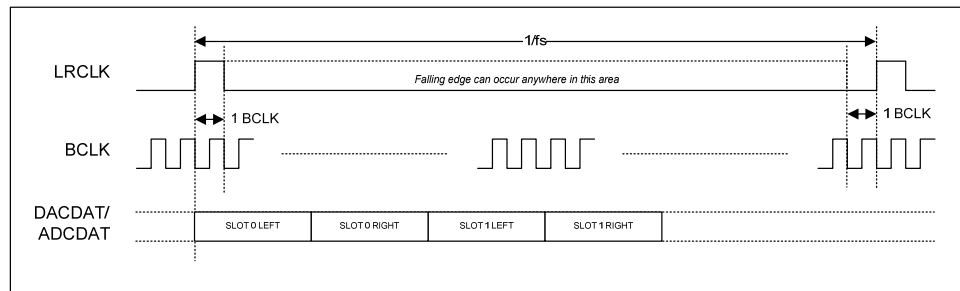

Figure 62 TDM in DSP Mode B

DIGITAL AUDIO INTERFACE CONTROL

This section describes the configuration of the WM8958 digital audio interface paths.

Interfaces AIF1 and AIF2 can be configured as Master or Slave, or can be tri-stated. Each input and output signal path can be independently enabled or disabled. AIF output (digital record) and AIF input (digital playback) paths can use a common Left/Right clock, or can use separate clocks for mixed sample rates.

Interfaces AIF1 and AIF2 each support flexible formats, word-length, TDM configuration, channel swapping and input path digital boost functions. 8-bit companding modes and digital loopback is also possible.

A third interface, AIF3, supports Mono PCM digital audio paths to/from the AIF2 DSP functions. AIF3 can also be configured using multiplexers to provide alternate connections to AIF1 or AIF2. Note that AIF3 operates in Master mode only.

AIF1 - MASTER / SLAVE AND TRI-STATE CONTROL

The Digital Audio Interface AIF1 can operate in Master or Slave modes, selected by AIF1_MSTR. In Master mode, the BCLK1 and LRCLK1 signals are generated by the WM8958 when one or more AIF1 channels is enabled.

When AIF1_LRCLK_FRC or AIF1_CLK_FRC is set in Master mode, then LRCLK1 and ADCLRCLK1 are output at all times, including when none of the AIF1 audio channels is enabled. Note that LRCLK1 and ADCLRCLK1 are derived from BCLK1, and either an internal or external BCLK1 signal must also be present to generate LRCLK1 or ADCLRCLK1.

When AIF1_CLK_FRC is set in Master mode, then BCLK1 is output at all times, including when none of the AIF1 audio channels is enabled.

The AIF1 interface can be tri-stated by setting the AIF1_TRI register. When this bit is set, then all of the AIF1 outputs are un-driven (high-impedance). Note that the GPIO1/ADCLRCLK1 pin is a configurable pin which may take different functions independent of AIF1. The AIF1_TRI register only controls the GPIO1/ADCLRCLK1 pin when its function is set to ADCLRCLK1. See "General Purpose Input/Output" to configure the GPIO1 pin.

REGISTER ADDRESS	BIT	LABEL	DEFAULT	DESCRIPTION
R770 (0302h) AIF1 Master/Slave	15	AIF1_TRI	0	AIF1 Audio Interface tri-state 0 = AIF1 pins operate normally 1 = Tri-state all AIF1 interface pins Note that the GPIO1 pin is controlled by this register only when configured as ADCLRCLK1.
	14	AIF1_MSTR	0	AIF1 Audio Interface Master Mode Select 0 = Slave mode 1 = Master mode
	13	AIF1_CLK_FRC	0	Forces BCLK1, LRCLK1 and ADCLRCLK1 to be enabled when all AIF1 audio channels are disabled. 0 = Normal 1 = BCLK1, LRCLK1 and ADCLRCLK1 always enabled in Master mode
	12	AIF1_LRCLK_FRC	0	Forces LRCLK1 and ADCLRCLK1 to be enabled when all AIF1 audio channels are disabled. 0 = Normal 1 = LRCLK1 and ADCLRCLK1 always enabled in Master mode

Table 91 AIF1 Master / Slave and Tri-state Control

AIF1 - SIGNAL PATH ENABLE

The AIF1 interface supports up to four input channels and up to four output channels. All enabled channels are transmitted (on ADCDAT) or received (on DACDAT) sequentially, using time division multiplexing (TDM).

Each of the available channels can be enabled or disabled using the register bits defined in Table 92. These register controls are illustrated in Figure 67.

REGISTER ADDRESS	BIT	LABEL	DEFAULT	DESCRIPTION
R4 (0004h) Power Management (4)	11	AIF1ADC2L_ENA	0	Enable AIF1ADC2 (Left) output path (AIF1, Timeslot 1) 0 = Disabled 1 = Enabled
	10	AIF1ADC2R_ENA	0	Enable AIF1ADC2 (Right) output path (AIF1, Timeslot 1) 0 = Disabled 1 = Enabled
	9	AIF1ADC1L_ENA	0	Enable AIF1ADC1 (Left) output path (AIF1, Timeslot 0) 0 = Disabled 1 = Enabled
	8	AIF1ADC1R_ENA	0	Enable AIF1ADC1 (Right) output path (AIF1, Timeslot 0) 0 = Disabled 1 = Enabled
R5 (0005h) Power Management (5)	11	AIF1DAC2L_ENA	0	Enable AIF1DAC2 (Left) input path (AIF1, Timeslot 1) 0 = Disabled 1 = Enabled
	10	AIF1DAC2R_ENA	0	Enable AIF1DAC2 (Right) input path (AIF1, Timeslot 1) 0 = Disabled 1 = Enabled
	9	AIF1DAC1L_ENA	0	Enable AIF1DAC1 (Left) input path (AIF1, Timeslot 0) 0 = Disabled 1 = Enabled
	8	AIF1DAC1R_ENA	0	Enable AIF1DAC1 (Right) input path (AIF1, Timeslot 0) 0 = Disabled 1 = Enabled

Table 92 AIF1 Signal Path Enable

AIF1 - BCLK AND LRCLK CONTROL

The BCLK1 frequency is controlled relative to AIF1CLK by the AIF1_BCLK_DIV divider. See “Clocking and Sample Rates” for details of the AIF1 clock, AIF1CLK.

The LRCLK1 frequency is controlled relative to BCLK1 by the AIF1DAC_RATE divider.

In Master mode, the LRCLK1 output is generated by the WM8958 when any of the AIF1 channels is enabled. (Note that, when GPIO1 is configured as ADCLRCLK1, then only the AIF1 DAC channels will cause LRCLK1 to be output.)

In Slave mode, the LRCLK1 output is disabled by default to allow another digital audio interface to drive this pin. It is also possible to force the LRCLK1 signal to be output, using the AIF1DAC_LRCLK_DIR or AIF1ADC_LRCLK_DIR register bits, allowing mixed master and slave modes. (Note that, when GPIO1 is configured as ADCLRCLK1, then only the AIF1DAC_LRCLK_DIR bit will force the LRCLK1 signal.)

When the GPIO1 pin is configured as ADCLRCLK1, then the ADCLRCLK1 frequency is controlled relative to BCLK1 by the AIF1ADC_RATE divider. In this case, the ADCLRCLK1 is dedicated to AIF1 output, and the LRCLK1 pin is dedicated to AIF1 input, allowing different sample rates to be supported in the two paths.

In Master mode, with GPIO1 pin configured as ADCLRCLK1, this output is enabled when any of the AIF1 ADC channels is enabled. The ADCLRCLK1 signal can also be enabled in Slave mode, using the AIF1ADC_LRCLK_DIR bit, allowing mixed master and slave modes.

When the GPIO1 pin is not configured as ADCLRCLK1, then the LRCLK1 signal applies to the ADC and DAC channels, at a rate set by AIF1ADC_RATE.

See “General Purpose Input/Output” for the configuration of GPIO1. Note that, in Ultrasonic (4FS) mode, the GPIO1 pin must be configured as ADCLRCLK1.

The BCLK1 output can be inverted using the AIF1_BCLK_INV register bit. The LRCLK1 and ADCLRCLK1 output (when selected) can be inverted using the AIF1DAC_LRCLK_INV and AIF1ADC_LRCLK_INV register controls respectively.

Note that in Slave mode, when BCLK1 is an input, the AIF1_BCLK_INV register selects the polarity of the received BCLK1 signal. Under default conditions, DACDAT1 input is captured on the rising edge of BCLK1, as illustrated in Figure 5. When AIF1_BCLK_INV = 1, DACDAT1 input is captured on the falling edge of BCLK1.

The AIF1 clock generators are controlled as illustrated in Figure 63.

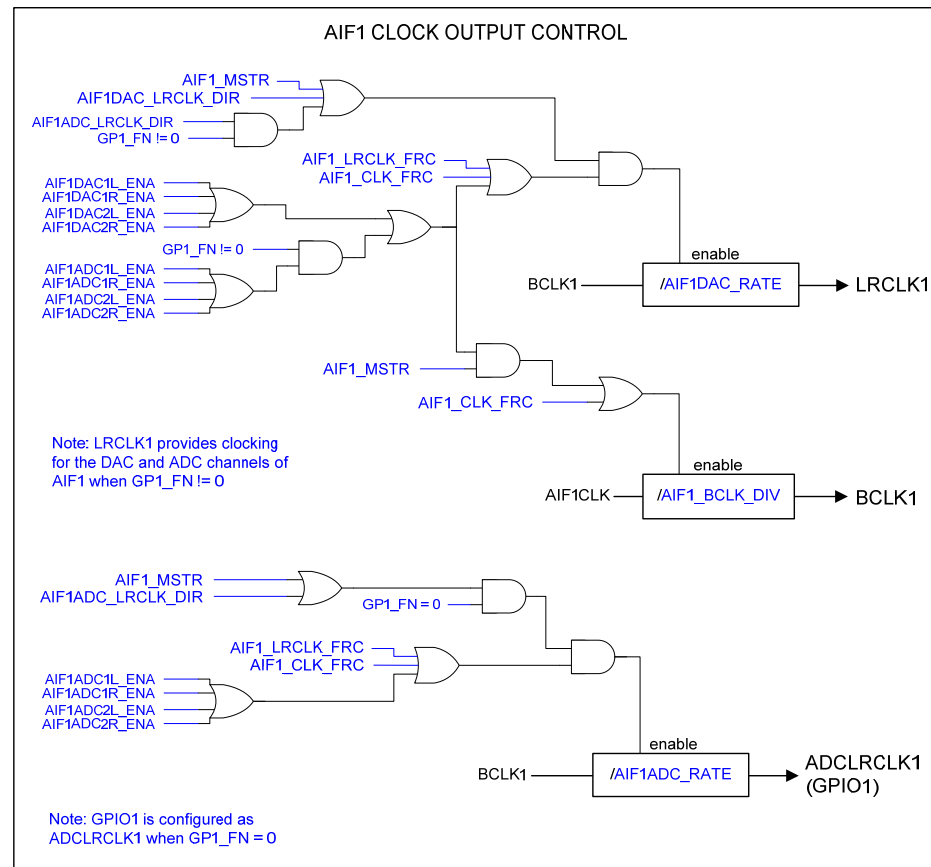

Figure 63 Audio Interface 1 - BCLK and LRCLK Control

REGISTER ADDRESS	BIT	LABEL	DEFAULT	DESCRIPTION
R768 (0300h) AIF1 Control (1)	8	AIF1_BCLK_INV	0	BCLK1 Invert 0 = BCLK1 not inverted 1 = BCLK1 inverted Note that AIF1_BCLK_INV selects the BCLK1 polarity in Master mode and in Slave mode.
R771 (0303h) AIF1 BCLK	8:4	AIF1_BCLK_DIV [4:0]	00100	BCLK1 Rate 00000 = AIF1CLK 00001 = AIF1CLK / 1.5 00010 = AIF1CLK / 2 00011 = AIF1CLK / 3 00100 = AIF1CLK / 4 00101 = AIF1CLK / 5 00110 = AIF1CLK / 6 00111 = AIF1CLK / 8 01000 = AIF1CLK / 11 01001 = AIF1CLK / 12 01010 = AIF1CLK / 16 01011 = AIF1CLK / 22 01100 = AIF1CLK / 24 01101 = AIF1CLK / 32 01110 = AIF1CLK / 44 01111 = AIF1CLK / 48 10000 = AIF1CLK / 64 10001 = AIF1CLK / 88 10010 = AIF1CLK / 96 10011 = AIF1CLK / 128 10100 = AIF1CLK / 176 10101 = AIF1CLK / 192 10110 - 11111 = Reserved
R772 (0304h) AIF1ADC LRCLK	12	AIF1ADC_LRCLK_INV	0	Right, left and I ² S modes – ADCLRCLK1 polarity 0 = normal ADCLRCLK1 polarity 1 = invert ADCLRCLK1 polarity Note that AIF1ADC_LRCLK_INV selects the ADCLRCLK1 polarity in Master mode and in Slave mode. DSP Mode – mode A/B select 0 = MSB is available on 2nd BCLK1 rising edge after ADCLRCLK1 rising edge (mode A) 1 = MSB is available on 1st BCLK1 rising edge after ADCLRCLK1 rising edge (mode B)
	11	AIF1ADC_LRCLK_DIR	0	Allows ADCLRCLK1 to be enabled in Slave mode 0 = Normal 1 = ADCLRCLK1 enabled in Slave mode
	10:0	AIF1ADC_RATE [10:0]	040h	ADCLRCLK1 Rate ADCLRCLK1 clock output = BCLK1 / AIF1ADC_RATE Integer (LSB = 1) Valid from 8..2047

REGISTER ADDRESS	BIT	LABEL	DEFAULT	DESCRIPTION
R773 (0305h) AIF1DAC LRCLK	12	AIF1DAC_L RCLK_INV	0	Right, left and I ² S modes – LRCLK1 polarity 0 = normal LRCLK1 polarity 1 = invert LRCLK1 polarity Note that AIF1DAC_LRCLK_INV selects the LRCLK1 polarity in Master mode and in Slave mode. DSP Mode – mode A/B select 0 = MSB is available on 2nd BCLK1 rising edge after LRCLK1 rising edge (mode A) 1 = MSB is available on 1st BCLK1 rising edge after LRCLK1 rising edge (mode B)
	11	AIF1DAC_L RCLK_DIR	0	Allows LRCLK1 to be enabled in Slave mode 0 = Normal 1 = LRCLK1 enabled in Slave mode
	10:0	AIF1DAC_R ATE [10:0]	040h	LRCLK1 Rate LRCLK1 clock output = BCLK1 / AIF1DAC_RATE Integer (LSB = 1) Valid from 8..2047

Table 93 AIF1 BCLK and LRCLK Control

AIF1 - DIGITAL AUDIO DATA CONTROL

The register bits controlling the audio data format, word length, left/right channel selection and TDM control for AIF1 are described in Table 94.

In DSP mode, the left channel MSB is available on either the 1st (mode B) or 2nd (mode A) rising edge of BCLK following a rising edge of LRCLK (assuming default BCLK polarity).

When the AIF1DAC_LRCLK_INV bit is set in DSP mode, then DSP Mode B is selected for the AIF1 digital input (playback) signal path. When the AIF1DAC_LRCLK_INV bit is not set, then DSP Mode A is selected.

When the AIF1ADC_LRCLK_INV bit is set in DSP mode, then DSP Mode B is selected for the AIF1 digital output (record) signal path. When the AIF1ADC_LRCLK_INV bit is not set, then DSP Mode A is selected.

Note that the DSP Mode is selected independently for the input/output paths of each digital audio interface. Also note that the AIF1ADCLRCLK_INV bits remain valid even when the LRCLK signal is common for both paths. See Table 93 for details of the AIF1DAC_LRCLK_INV and AIF1ADC_LRCLK_INV register fields.

A digital gain function is available at the audio interface input path to boost the DAC volume when a small signal is received on DACDAT1. This is controlled using the AIF1DAC_BOOST register. To prevent clipping, this function should not be used when the boosted data is expected to be greater than 0dBFS.

REGISTER ADDRESS	BIT	LABEL	DEFAULT	DESCRIPTION
R768 (0300h) AIF1 Control (1)	15	AIF1ADCL_ SRC	0	AIF1 Left Digital Audio interface source 0 = Left ADC data is output on left channel 1 = Right ADC data is output on left channel
	14	AIF1ADCR_ SRC	1	AIF1 Right Digital Audio interface source 0 = Left ADC data is output on right channel 1 = Right ADC data is output on right channel

REGISTER ADDRESS	BIT	LABEL	DEFAULT	DESCRIPTION
	13	AIF1ADC_TDM	0	AIF1 transmit (ADC) TDM Control 0 = ADCDAT1 drives logic '0' when not transmitting data 1 = ADCDAT1 is tri-stated when not transmitting data
	6:5	AIF1_WL [1:0]	10	AIF1 Digital Audio Interface Word Length 00 = 16 bits 01 = 20 bits 10 = 24 bits 11 = 32 bits Note - 8-bit modes can be selected using the "Companding" control bits.
	4:3	AIF1_FMT [1:0]	10	AIF1 Digital Audio Interface Format 00 = Right justified 01 = Left justified 10 = I ² S Format 11 = DSP Mode
R769 (0301h) AIF1 Control (2)	15	AIF1DACL_SRC	0	AIF1 Left Receive Data Source Select 0 = Left DAC receives left interface data 1 = Left DAC receives right interface data
	14	AIF1DACR_SRC	1	AIF1 Right Receive Data Source Select 0 = Right DAC receives left interface data 1 = Right DAC receives right interface data
	11:10	AIF1DAC_BOOST [1:0]	00	AIF1 Input Path Boost 00 = 0dB 01 = +6dB (input must not exceed -6dBFS) 10 = +12dB (input must not exceed -12dBFS) 11 = +18dB (input must not exceed -18dBFS)
R774 (0306h) AIF1 DAC Data	1	AIF1DACL_DAT_INV	0	AIF1 Left Receive Data Invert 0 = Not inverted 1 = Inverted
	0	AIF1DACR_DAT_INV	0	AIF1 Right Receive Data Invert 0 = Not inverted 1 = Inverted
R775 (0307h) AIF1 ADC Data	1	AIF1ADCL_DAT_INV	0	AIF1 Left Transmit Data Invert 0 = Not inverted 1 = Inverted
	0	AIF1ADCR_DAT_INV	0	AIF1 Right Transmit Data Invert 0 = Not inverted 1 = Inverted

Table 94 AIF1 Digital Audio Data Control

AIF1 - MONO MODE

AIF1 can be configured to operate in mono DSP mode by setting AIF1_MONO = 1 as described in Table 95. Note that mono mode is only supported in DSP mode, ie when AIF1_FMT = 11.

In mono mode, the Left channel data or the Right channel data may be selected for output on ADCDAT1. The selected channel is determined by the AIF1ADC1L_ENA and AIF1ADC1R_ENA bits. (If both bits are set, then the Right channel data is selected.)

In mono mode, the DACDAT1 input can be enabled on the Left and/or Right signal paths using the AIF1DAC1L_ENA and AIF1DAC1R_ENA bits. The mono input can be enabled on both paths at the same time if required.

Note that AIF1 TDM mode and AIF1 Mono mode cannot be supported simultaneously.

REGISTER ADDRESS	BIT	LABEL	DEFAULT	DESCRIPTION
R769 (0301h) AIF1 Control (2)	8	AIF1_MONO	0	AIF1 DSP Mono Mode 0 = Disabled 1 = Enabled Note that Mono Mode is only supported when AIF1_FMT = 11.

Table 95 AIF1 Mono Mode Control

AIF1 - COMPANDING

The WM8958 supports A-law and μ -law companding on both transmit (ADC) and receive (DAC) sides of AIF1. This is configured using the register bits described in Table 96.

REGISTER ADDRESS	BIT	LABEL	DEFAULT	DESCRIPTION
R769 (0301h) AIF1 Control (2)	4	AIF1DAC_C OMP	0	AIF1 Receive Companding Enable 0 = Disabled 1 = Enabled
	3	AIF1DAC_C OMPMODE	0	AIF1 Receive Companding Type 0 = μ -law 1 = A-law
	2	AIF1ADC_C OMP	0	AIF1 Transmit Companding Enable 0 = Disabled 1 = Enabled
	1	AIF1ADC_C OMPMODE	0	AIF1 Transmit Companding Type 0 = μ -law 1 = A-law

Table 96 AIF1 Companding

Companding involves using a piecewise linear approximation of the following equations (as set out by ITU-T G.711 standard) for data compression:

μ -law (where $\mu=255$ for the U.S. and Japan):

$$F(x) = \ln(1 + \mu|x|) / \ln(1 + \mu) \quad \} \text{ for } -1 \leq x \leq 1$$

A-law (where $A=87.6$ for Europe):

$$F(x) = A|x| / (1 + \ln A) \quad \} \text{ for } x \leq 1/A$$

$$F(x) = (1 + \ln A|x|) / (1 + \ln A) \quad \} \text{ for } 1/A \leq x \leq 1$$

The companded data is also inverted as recommended by the G.711 standard (all 8 bits are inverted for μ -law, all even data bits are inverted for A-law). The data will be transmitted as the first 8 MSBs of data.

Companding converts 13 bits (μ -law) or 12 bits (A-law) to 8 bits using non-linear quantization. This provides greater precision for low amplitude signals than for high amplitude signals, resulting in a greater usable dynamic range than 8 bit linear quantization. The companded signal is an 8-bit word comprising sign (1 bit), exponent (3 bits) and mantissa (4 bits).

AIF1 8-bit mode is selected whenever AIF1DAC_COMP=1 or AIF1ADC_COMP=1. The use of 8-bit data allows samples to be passed using as few as 8 BCLK1 cycles per LRCLK1 frame. When using DSP mode B, 8-bit data words may be transferred consecutively every 8 BCLK1 cycles.

AIF1 8-bit mode (without Companding) may be enabled by setting AIF1DAC_COMPMODE=1 or AIF1ADC_COMPMODE=1, when AIF1DAC_COMP=0 and AIF1ADC_COMP=0.

BIT7	BIT[6:4]	BIT[3:0]
SIGN	EXPONENT	MANTISSA

Table 97 8-bit Companded Word Composition

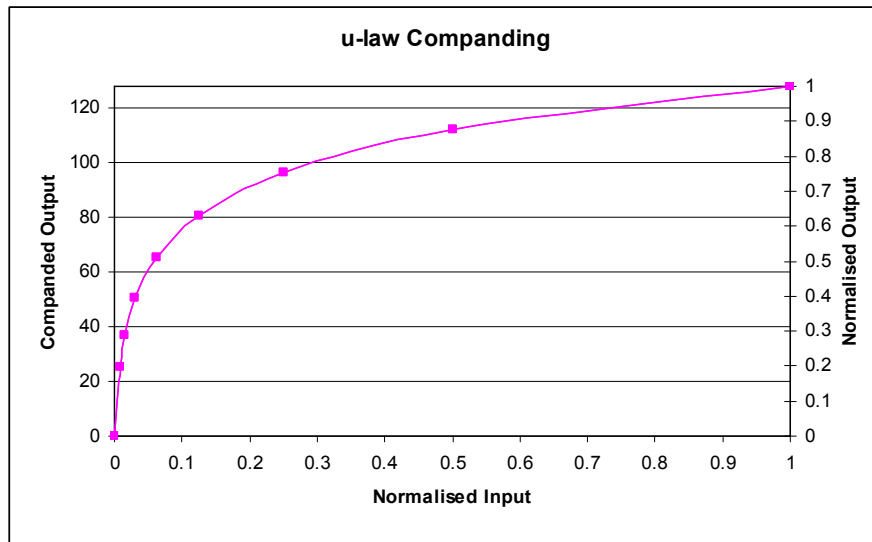

Figure 64 μ -Law Companding

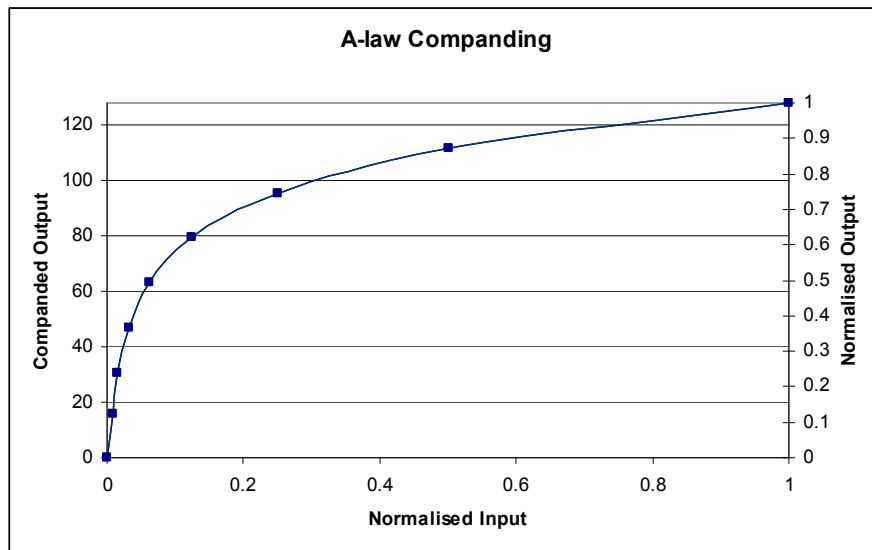

Figure 65 A-Law Companding

AIF1 - LOOPBACK

The AIF1 interface can provide a Loopback option. When the AIF1_LOOPBACK bit is set, then AIF1 digital audio output is routed to the AIF1 digital audio input. The normal input (DACDAT1) is not used when AIF1 Loopback is enabled.

REGISTER ADDRESS	BIT	LABEL	DEFAULT	DESCRIPTION
R769 (0301h) AIF1 Control (2)	0	AIF1_LOOPBACK	0	AIF1 Digital Loopback Function 0 = No loopback 1 = Loopback enabled (ADCDAT1 data output is directly input to DACDAT1 data input).

Table 98 AIF1 Loopback**AIF1 - DIGITAL PULL-UP AND PULL-DOWN**

The WM8958 provides integrated pull-up and pull-down resistors on each of the DACDAT1, LRCLK1 and BCLK1 pins. This provides a flexible capability for interfacing with other devices.

Each of the pull-up and pull-down resistors can be configured independently using the register bits described in Table 99. Note that if the Pull-up and Pull-down are both enabled for any pin, then the pull-up and pull-down will be disabled.

REGISTER ADDRESS	BIT	LABEL	DEFAULT	DESCRIPTION
R1824 (0720h) Pull Control (1)	5	DACDAT1_PU	0	DACDAT1 Pull-up enable 0 = Disabled 1 = Enabled
	4	DACDAT1_PD	0	DACDAT1 Pull-down enable 0 = Disabled 1 = Enabled
	3	DACLCLK1_PU	0	LRCLK1 Pull-up enable 0 = Disabled 1 = Enabled
	2	DACLCLK1_PD	0	LRCLK1 Pull-down enable 0 = Disabled 1 = Enabled
	1	BCLK1_PU	0	BCLK1 Pull-up enable 0 = Disabled 1 = Enabled
	0	BCLK1_PD	0	BCLK1 Pull-down enable 0 = Disabled 1 = Enabled

Table 99 AIF1 Digital Pull-Up and Pull-Down Control

AIF2 - MASTER / SLAVE AND TRI-STATE CONTROL

The Digital Audio Interface AIF2 can operate in Master or Slave modes, selected by AIF2_MSTR. In Master mode, the BCLK2 and LRCLK2 signals are generated by the WM8958 when one or more AIF2 channels is enabled.

When AIF2_LRCLK_FRC or AIF2_CLK_FRC is set in Master mode, then LRCLK2 and ADCLRCLK2 are output at all times, including when none of the AIF2 audio channels is enabled. Note that LRCLK2 and ADCLRCLK2 are derived from BCLK2, and either an internal or external BCLK2 signal must also be present to generate LRCLK2 or ADCLRCLK2.

When AIF2_CLK_FRC is set in Master mode, then BCLK2 is output at all times, including when none of the AIF2 audio channels is enabled.

Note that the ADCLRCLK2 pin is also a GPIO pin, whose function is configurable. This pin must be configured for AIF functionality when used as audio interface pin. See "General Purpose Input/Output".

The AIF2 interface can be tri-stated by setting the AIF2_TRI register. When this bit is set, then all of the AIF2 outputs are un-driven (high-impedance). The AIF2_TRI register only affects those pins which are configured for AIF2 functions; it does not affect pins which are configured for other functions.

REGISTER ADDRESS	BIT	LABEL	DEFAULT	DESCRIPTION
R786 (0312h) AIF2 Master/Slave	15	AIF2_TRI	0	AIF2 Audio Interface tri-state 0 = AIF2 pins operate normally 1 = Tri-state all AIF2 interface pins Note that pins not configured as AIF2 functions are not affected by this register.
	14	AIF2_MSTR	0	AIF2 Audio Interface Master Mode Select 0 = Slave mode 1 = Master mode
	13	AIF2_CLK_FRC	0	Forces BCLK2, LRCLK2 and ADCLRCLK2 to be enabled when all AIF2 audio channels are disabled. 0 = Normal 1 = BCLK2, LRCLK2 and ADCLRCLK2 always enabled in Master mode
	12	AIF2_LRCLK_FRC	0	Forces LRCLK2 and ADCLRCLK2 to be enabled when all AIF2 audio channels are disabled. 0 = Normal 1 = LRCLK2 and ADCLRCLK2 always enabled in Master mode

Table 100 AIF2 Master / Slave and Tri-state Control

AIF2 - SIGNAL PATH ENABLE

The AIF2 interface supports two input channels and two output channels. Each of the available channels can be enabled or disabled using the register bits defined in Table 101. These register controls are illustrated in Figure 67.

REGISTER ADDRESS	BIT	LABEL	DEFAULT	DESCRIPTION
R4 (0004h) Power Management (4)	13	AIF2ADCL_ENA	0	Enable AIF2ADC (Left) output path 0 = Disabled 1 = Enabled This bit must be set for AIF2 or AIF3 output of the AIF2ADC (Left) signal.
	12	AIF2ADCR_ENA	0	Enable AIF2ADC (Right) output path 0 = Disabled 1 = Enabled This bit must be set for AIF2 or AIF3 output of the AIF2ADC (Left) signal.
R5 (0005h) Power Management (5)	13	AIF2DAACL_ENA	0	Enable AIF2DAC (Left) input path 0 = Disabled 1 = Enabled
	12	AIF2DACR_ENA	0	Enable AIF2DAC (Right) input path 0 = Disabled 1 = Enabled
R784 (0310h) AIF2 Control (1)	1	AIF2TXL_ENA	1	Enable AIF2DAC (Left) input path 0 = Disabled 1 = Enabled This bit must be set for AIF2 output of the AIF2ADC (Left) signal. For AIF3 output only, this bit can be set to 0.
	0	AIF2TXR_ENA	1	Enable AIF2DAC (Right) input path 0 = Disabled 1 = Enabled This bit must be set for AIF2 output of the AIF2ADC (Left) signal. For AIF3 output only, this bit can be set to 0.

Table 101 AIF2 Signal Path Enable

AIF2 - BCLK AND LRCLK CONTROL

The BCLK2 frequency is controlled relative to AIF2CLK by the AIF2_BCLK_DIV divider. See “Clocking and Sample Rates” for details of the AIF2 clock, AIF2CLK.

The LRCLK2 frequency is controlled relative to BCLK2 by the AIF2DAC_RATE divider.

In Master mode, the LRCLK2 output is generated by the WM8958 when any of the AIF2 channels is enabled. (Note that, when GPIO6 is configured as ADCLRCLK2, then only the AIF2 DAC channels will cause LRCLK2 to be output.)

In Slave mode, the LRCLK2 output is disabled by default to allow another digital audio interface to drive this pin. It is also possible to force the LRCLK2 signal to be output, using the AIF2DAC_LRCLK_DIR or AIF2ADC_LRCLK_DIR register bits, allowing mixed master and slave modes. (Note that, when GPIO6 is configured as ADCLRCLK2, then only the AIF2DAC_LRCLK_DIR bit will force the LRCLK2 signal.)

When the GPIO6 pin is configured as ADCLRCLK2, then the ADCLRCLK2 frequency is controlled relative to BCLK2 by the AIF2ADC_RATE divider. In this case, the ADCLRCLK2 is dedicated to AIF2 output, and the LRCLK2 pin is dedicated to AIF2 input, allowing different sample rates to be supported in the two paths.

In Master mode, with GPIO6 pin configured as ADCLRCLK2, this output is enabled when any of the AIF2 ADC channels is enabled. The ADCLRCLK2 signal can also be enabled in Slave mode, using the AIF2ADC_LRCLK_DIR bit, allowing mixed master and slave modes.

See “General Purpose Input/Output” for the configuration of GPIO6.

The BCLK2 output can be inverted using the AIF2_BCLK_INV register bit. The LRCLK2 and ADCLRCLK2 output (when selected) can be inverted using the AIF2DAC_LRCLK_INV and AIF2ADC_LRCLK_INV register controls respectively.

Note that in Slave mode, when BCLK2 is an input, the AIF2_BCLK_INV register selects the polarity of the received BCLK2 signal. Under default conditions, DACDAT2 input is captured on the rising edge of BCLK2, as illustrated in Figure 5. When AIF2_BCLK_INV = 1, DACDAT2 input is captured on the falling edge of BCLK2.

The AIF2 clock generators are controlled as illustrated in Figure 66.

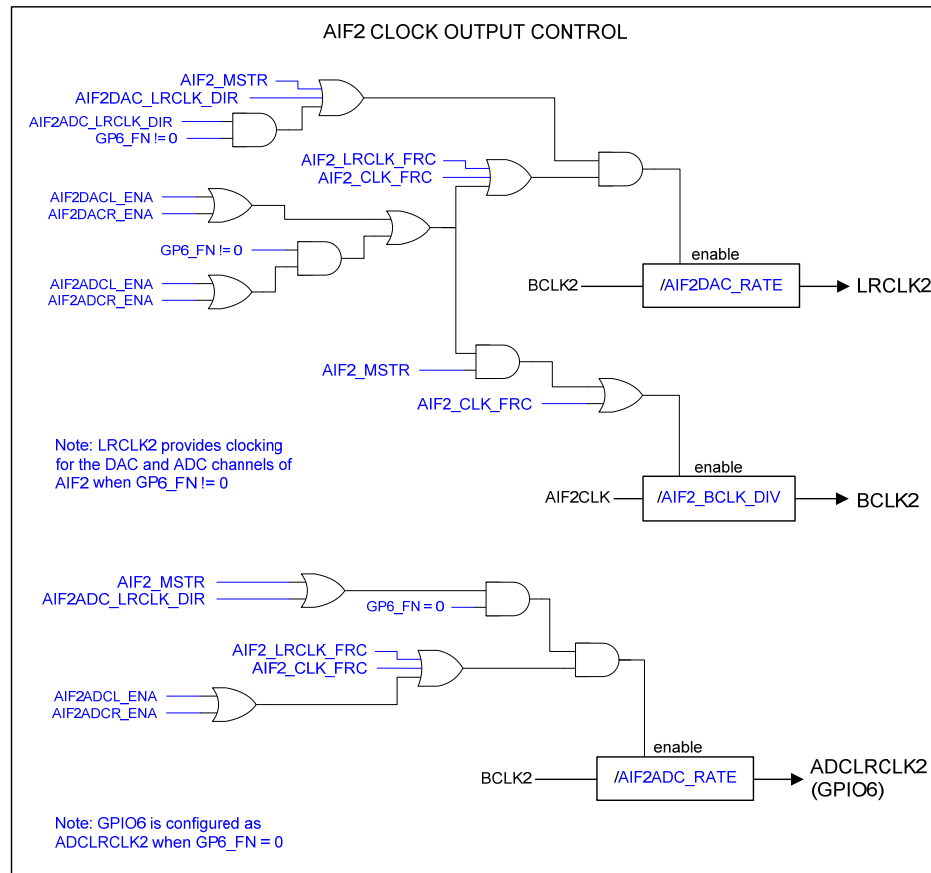

Figure 66 Audio Interface 2 - BCLK and LRCLK Control

REGISTER ADDRESS	BIT	LABEL	DEFAULT	DESCRIPTION
R784 (0310h) AIF2 Control (1)	8	AIF2_BCLK_INV	0	BCLK2 Invert 0 = BCLK2 not inverted 1 = BCLK2 inverted Note that AIF2_BCLK_INV selects the BCLK2 polarity in Master mode and in Slave mode.
R787 (0313h) AIF2 BCLK	8:4	AIF2_BCLK_DIV [4:0]	00100	BCLK2 Rate 00000 = AIF2CLK 00001 = AIF2CLK / 1.5 00010 = AIF2CLK / 2 00011 = AIF2CLK / 3 00100 = AIF2CLK / 4 00101 = AIF2CLK / 5 00110 = AIF2CLK / 6 00111 = AIF2CLK / 8 01000 = AIF2CLK / 11 01001 = AIF2CLK / 12 01010 = AIF2CLK / 16 01011 = AIF2CLK / 22 01100 = AIF2CLK / 24 01101 = AIF2CLK / 32 01110 = AIF2CLK / 44 01111 = AIF2CLK / 48 10000 = AIF2CLK / 64 10001 = AIF2CLK / 88 10010 = AIF2CLK / 96 10011 = AIF2CLK / 128 10100 = AIF2CLK / 176 10101 = AIF2CLK / 192 10110 - 11111 = Reserved
R788 (0314h) AIF2ADC LRCLK	12	AIF2ADC_LRCLK_INV	0	Right, left and I ² S modes – ADCLRCLK2 polarity 0 = normal ADCLRCLK2 polarity 1 = invert ADCLRCLK2 polarity Note that AIF2ADC_LRCLK_INV selects the ADCLRCLK2 polarity in Master mode and in Slave mode.
				DSP Mode – mode A/B select 0 = MSB is available on 2nd BCLK2 rising edge after ADCLRCLK2 rising edge (mode A) 1 = MSB is available on 1st BCLK2 rising edge after ADCLRCLK2 rising edge (mode B)
	11	AIF2ADC_LRCLK_DIR	0	Allows ADCLRCLK2 to be enabled in Slave mode 0 = Normal 1 = ADCLRCLK2 enabled in Slave mode
	10:0	AIF2ADC_RATE [10:0]	040h	ADCLRCLK2 Rate ADCLRCLK2 clock output = BCLK2 / AIF2ADC_RATE Integer (LSB = 1) Valid from 8..2047
R789 (0315h) AIF2DAC LRCLK	12	AIF2DAC_LRCLK_INV	0	Right, left and I ² S modes – LRCLK2 polarity 0 = normal LRCLK2 polarity 1 = invert LRCLK2 polarity Note that AIF2DAC_LRCLK_INV selects the LRCLK2 polarity in Master mode and in Slave mode.

REGISTER ADDRESS	BIT	LABEL	DEFAULT	DESCRIPTION
				DSP Mode – mode A/B select 0 = MSB is available on 2nd BCLK2 rising edge after LRCLK2 rising edge (mode A) 1 = MSB is available on 1st BCLK2 rising edge after LRCLK2 rising edge (mode B)
	11	AIF2DAC_L RCLK_DIR	0	Allows LRCLK2 to be enabled in Slave mode 0 = Normal 1 = LRCLK2 enabled in Slave mode
	10:0	AIF2DAC_R ATE [10:0]	040h	LRCLK2 Rate LRCLK2 clock output = BCLK2 / AIF2DAC_RATE Integer (LSB = 1) Valid from 8..2047

Table 102 AIF2 BCLK and LRCLK Control

AIF2 - DIGITAL AUDIO DATA CONTROL

The register bits controlling the audio data format, word length, left/right channel selection and TDM control for AIF2 are described in Table 103.

When TDM mode is enabled on AIF2, the WM8958 can transmit and receive audio data in Slot 0 or Slot 1. In this case, the ADCDAT2 output is tri-stated during the unused timeslot, allowing another device to transmit data on the same pin. See “Signal Timing Requirements” for the associated timing details. (Note that, when TDM is not enabled on AIF2, the ADCDAT2 output is driven logic ‘0’ during the unused timeslot.)

In DSP mode, the left channel MSB is available on either the 1st (mode B) or 2nd (mode A) rising edge of BCLK following a rising edge of LRCLK (assuming default BCLK polarity).

When the AIF2DAC_LRCLK_INV bit is set in DSP mode, then DSP Mode B is selected for the AIF2 digital input (playback) signal path. When the AIF2DAC_LRCLK_INV bit is not set, then DSP Mode A is selected.

When the AIF2ADC_LRCLK_INV bit is set in DSP mode, then DSP Mode B is selected for the AIF2 digital output (record) signal path. When the AIF2ADC_LRCLK_INV bit is not set, then DSP Mode A is selected.

Note that the DSP Mode is selected independently for the input/output paths of each digital audio interface. Also note that the AIF2ADCLRCLK_INV bits remain valid even when the LRCLK signal is common for both paths. See Table 102 for details of the AIF2DAC_LRCLK_INV and AIF2ADC_LRCLK_INV register fields.

A digital gain function is available at the audio interface input path to boost the DAC volume when a small signal is received on ADCDAT2. This is controlled using the AIF2DAC_BOOST register. To prevent clipping, this function should not be used when the boosted data is expected to be greater than 0dBFS.

REGISTER ADDRESS	BIT	LABEL	DEFAULT	DESCRIPTION
R784 (0310h) AIF2 Control (1)	15	AIF2ADCL_ SRC	0	AIF2 Left Digital Audio interface source 0 = Left ADC data is output on left channel 1 = Right ADC data is output on left channel
	14	AIF2ADCR_ SRC	1	AIF2 Right Digital Audio interface source 0 = Left ADC data is output on right channel 1 = Right ADC data is output on right channel
	13	AIF2ADC_ TDM	0	AIF2 transmit (ADC) TDM Enable 0 = Normal ADCDAT2 operation 1 = TDM enabled on ADCDAT2

REGISTER ADDRESS	BIT	LABEL	DEFAULT	DESCRIPTION
	12	AIF2ADC_TDM_CHAN	0	AIF2 transmit (ADC) TDM Slot Select 0 = Slot 0 1 = Slot 1
	6:5	AIF2_WL [1:0]	10	AIF2 Digital Audio Interface Word Length 00 = 16 bits 01 = 20 bits 10 = 24 bits 11 = 32 bits Note - 8-bit modes can be selected using the "Companding" control bits.
	4:3	AIF2_FMT [1:0]	10	AIF2 Digital Audio Interface Format 00 = Right justified 01 = Left justified 10 = I ² S Format 11 = DSP Mode
R785 (0311h) AIF2 Control (2)	15	AIF2DACL_SRC	0	AIF2 Left Receive Data Source Select 0 = Left DAC receives left interface data 1 = Left DAC receives right interface data
	14	AIF2DACR_SRC	1	AIF2 Right Receive Data Source Select 0 = Right DAC receives left interface data 1 = Right DAC receives right interface data
	13	AIF2DAC_TDM	0	AIF2 receive (DAC) TDM Enable 0 = Normal DACDAT2 operation 1 = TDM enabled on DACDAT2
	12	AIF2DAC_TDM_CHAN	0	AIF2 receive (DAC) TDM Slot Select 0 = Slot 0 1 = Slot 1
	11:10	AIF2DAC_BOOST [1:0]	00	AIF2 Input Path Boost 00 = 0dB 01 = +6dB (input must not exceed -6dBFS) 10 = +12dB (input must not exceed -12dBFS) 11 = +18dB (input must not exceed -18dBFS)
R790 (0316h) AIF2 DAC Data	1	AIF2DACL_DAT_INV	0	AIF2 Left Receive Data Invert 0 = Not inverted 1 = Inverted
	0	AIF2DACR_DAT_INV	0	AIF2 Right Receive Data Invert 0 = Not inverted 1 = Inverted
R791 (0317h) AIF2 ADC Data	1	AIF2ADCL_DAT_INV	0	AIF2 Left Transmit Data Invert 0 = Not inverted 1 = Inverted
	0	AIF2ADCR_DAT_INV	0	AIF2 Right Transmit Data Invert 0 = Not inverted 1 = Inverted

Table 103 AIF2 Digital Audio Data Control

AIF2 - MONO MODE

AIF2 can be configured to operate in mono DSP mode by setting AIF2_MONO = 1 as described in Table 104. Note that mono mode is only supported in DSP mode, ie when AIF2_FMT = 11.

In mono mode, the Left channel data or the Right channel data may be selected for output on ADCDAT2. The selected channel is determined by the AIF2ADCL_ENA and AIF2ADCR_ENA bits. (If both bits are set, then the Right channel data is selected.)

In mono mode, the DACDAT2 input can be enabled on the Left and/or Right signal paths using the AIF2ADCL_ENA and AIF2ADCR_ENA bits. The mono input can be enabled on both paths at the same time if required.

REGISTER ADDRESS	BIT	LABEL	DEFAULT	DESCRIPTION
R785 (0311h) AIF2 Control (2)	8	AIF2_MONO	0	AIF2 DSP Mono Mode 0 = Disabled 1 = Enabled Note that Mono Mode is only supported when AIF2_FMT = 11.

Table 104 AIF2 Mono Mode Control**AIF2 - COMPANDING**

The WM8958 supports A-law and μ -law companding on both transmit (ADC) and receive (DAC) sides of AIF2. This is configured using the register bits described in Table 105.

For more details on Companding, see the Audio Interface AIF1 description above.

REGISTER ADDRESS	BIT	LABEL	DEFAULT	DESCRIPTION
R785 (0311h) AIF2 Control (2)	4	AIF2DAC_C OMP	0	AIF2 Receive Companding Enable 0 = Disabled 1 = Enabled
	3	AIF2DAC_C OMPMODE	0	AIF2 Receive Companding Type 0 = μ -law 1 = A-law
	2	AIF2ADC_C OMP	0	AIF2 Transmit Companding Enable 0 = Disabled 1 = Enabled
	1	AIF2ADC_C OMPMODE	0	AIF2 Transmit Companding Type 0 = μ -law 1 = A-law

Table 105 AIF2 Companding**AIF2 - LOOPBACK**

The AIF2 interface can provide a Loopback option. When the AIF2_LOOPBACK bit is set, then AIF2 digital audio output is routed to the AIF2 digital audio input. The normal input (DACDAT2) is not used when AIF2 Loopback is enabled.

REGISTER ADDRESS	BIT	LABEL	DEFAULT	DESCRIPTION
R785 (0311h) AIF2 Control (2)	0	AIF2_LOOP BACK	0	AIF2 Digital Loopback Function 0 = No loopback 1 = Loopback enabled (ADC DAT2 data output is directly input to DAC DAT2 data input).

Table 106 AIF2 Loopback

AIF2 - DIGITAL PULL-UP AND PULL-DOWN

The WM8958 provides integrated pull-up and pull-down resistors on each of the DACDAT2, DACLRCLK2 and BCLK2 pins. This provides a flexible capability for interfacing with other devices.

Each of the pull-up and pull-down resistors can be configured independently using the register bits described in Table 107. Note that if the Pull-up and Pull-down are both enabled for any pin, then the pull-up and pull-down will be disabled.

Note that pull-up and pull-down resistors are also provided on the GPIO6/ADCLRCLK2 pin; this is described in the "General Purpose Input/Output" section.

REGISTER ADDRESS	BIT	LABEL	DEFAULT	DESCRIPTION
R1794 (0702h) Pull Control (BCLK2)	14	BCLK2_PU	0	BCLK2 Pull-up enable 0 = Disabled 1 = Enabled
	13	BCLK2_PD	1	BCLK2 Pull-down enable 0 = Disabled 1 = Enabled
R1795 (0703h) Pull Control (DACLRCLK2)	14	DACLRCLK2_PU	0	DACLRCLK2 Pull-up enable 0 = Disabled 1 = Enabled
	13	DACLRCLK2_PD	1	DACLRCLK2 Pull-down enable 0 = Disabled 1 = Enabled
R1796 (0704h) Pull Control (DACDAT2)	14	DACDAT2_PU	0	DACDAT2 Pull-up enable 0 = Disabled 1 = Enabled
	13	DACDAT2_PD	1	DACDAT2 Pull-down enable 0 = Disabled 1 = Enabled

Table 107 AIF2 Digital Pull-Up and Pull-Down Control

AIF3 - SIGNAL PATH CONFIGURATION AND TRI-STATE CONTROL

The AIF3 interface provides Mono PCM digital audio paths to/from the AIF2 DSP functions. The AIF3 interface can also support stereo digital audio paths via multiplexers to provide alternate connections to AIF1 or AIF2. The relevant multiplexers are illustrated in Figure 67.

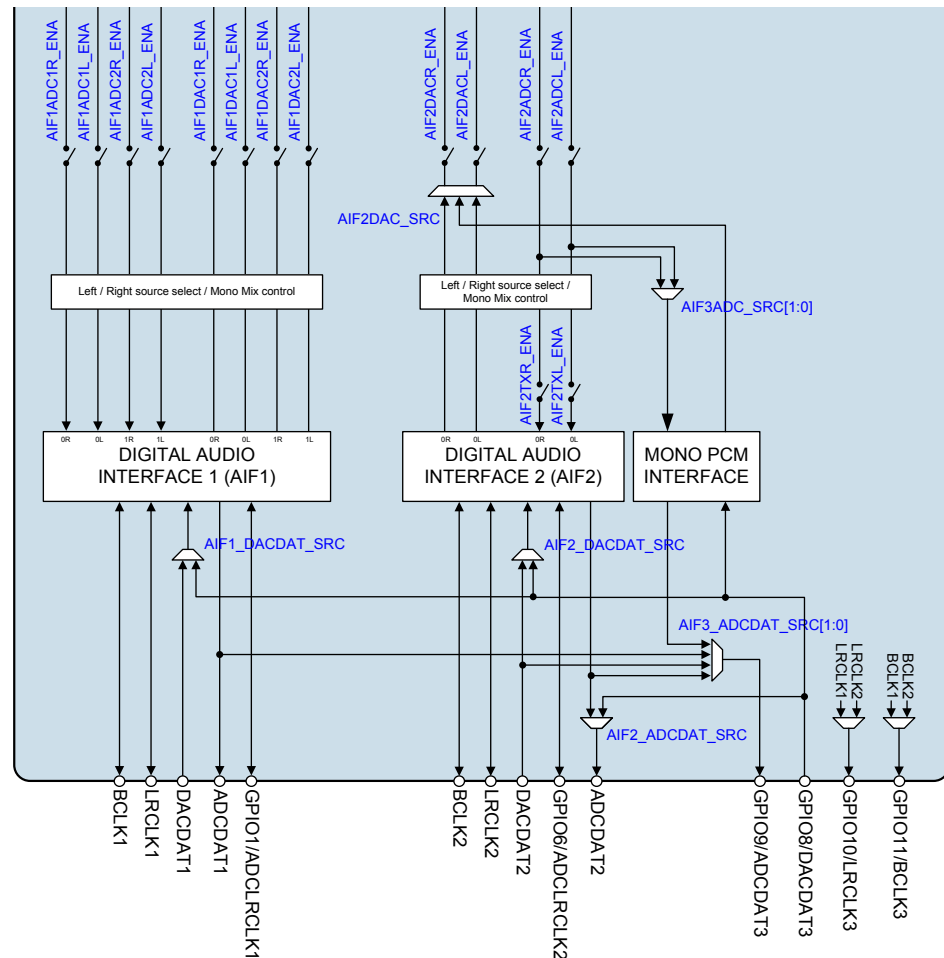

Figure 67 Audio Interface AIF3 Configuration

Note that all of the AIF3 connections are supported on pins which also provide GPIO functions. These pins must be configured as AIF functions when used as audio interface pins. See “General Purpose Input/Output”.

The GPIO8 pin supports the DACDAT3 function, which provides the input to the AIF3 Mono PCM interface.

When AIF3 Mono PCM input is used, this must be configured as an input to the AIF2 input paths using the AIF2DAC_SRC register as described in Table 108. The AIF3 Mono input may be selected on either channel (Left or Right), with AIF2 input enabled on the opposite channel at the same time.

When AIF3 Mono PCM input is used, the AIF2 input paths must be enabled using the AIF2DACR_ENA and AIF2DACL_ENA register bits defined in Table 101.

The DACDAT3 input pin can also be used as an input (mono or stereo) to AIF1 or AIF2. The data input source for AIF1 is selected using the AIF1_DACDAT_SRC register. The data input source for AIF2 is selected using the AIF2_DACDAT_SRC register.

The DACDAT3 input pin can also be routed to the ADCDAT2 output. The ADCDAT2 source is selected using the AIF2_ADCCDAT_SRC register.

The GPIO9 pin supports the ADCDAT3 function, which supports the output from the AIF3 Mono PCM interface. The source for the ADCDAT3 pin is selected using the AIF3_ADCDAT_SRC register.

When AIF3 Mono PCM output is used, the data source must be configured using the AIF3ADC_SRC register; this selects either the Left or Right AIF2 output paths as the data source.

When AIF3 Mono PCM output is used, the AIF2 output paths must be enabled using the AIF2ADCR_ENA and AIF2ADCL_ENA register bits. Note that, if AIF3 Mono PCM output is required and AIF2 output is not used, then the AIF2 output can be disabled using the AIF2TXL_ENA and AIF2TXR_ENA registers. See Table 101 for details of these registers.

The ADCDAT3 pin can also be used as an alternate data output (mono or stereo) from AIF1 or AIF2, or can be connected to the DACDAT2 data input.

The AIF3 interface can be tri-stated by setting the AIF3_TRI register. When this bit is set, then all of the AIF3 outputs are un-driven (high-impedance). The AIF3_TRI register only affects those pins which are configured for AIF3 functions; it does not affect pins which are configured for other functions.

The AIF3 control registers are described in Table 108.

REGISTER ADDRESS	BIT	LABEL	DEFAULT	DESCRIPTION
R6 (0006h) Power Management (6)	10:9	AIF3ADC_SRC [1:0]	00	AIF3 Mono PCM output source select 00 = None 01 = AIF2ADC (Left) output path 10 = AIF2ADC (Right) output path 11 = Reserved
	8:7	AIF2DAC_SRC [1:0]	00	AIF2 input path select 00 = Left and Right inputs from AIF2 01 = Left input from AIF2; Right input from AIF3 10 = Left input from AIF3; Right input from AIF2 11 = Reserved
	5	AIF3_TRI	0	AIF3 Audio Interface tri-state 0 = AIF3 pins operate normally 1 = Tri-state all AIF3 interface pins Note that pins not configured as AIF3 functions are not affected by this register.
	4:3	AIF3_ADCDAT_SRC [1:0]	00	GPIO9/ADCDAT3 Source select 00 = AIF1 ADCDAT1 01 = AIF2 ADCDAT2 10 = DACDAT2 11 = AIF3 Mono PCM output Note that GPIO9 must be configured as ADCDAT3.
	2	AIF2_ADCDAT_SRC	0	ADCDAT2 Source select 0 = AIF2 ADCDAT2 1 = GPIO8/DACDAT3 For selection 1, the GPIO8 pin must also be configured as DACDAT3.
	1	AIF2_DACDAT_SRC	0	AIF2 DACDAT Source select 0 = DACDAT2 1 = GPIO8/DACDAT3 For selection 1, the GPIO8 pin must also be configured as DACDAT3.

REGISTER ADDRESS	BIT	LABEL	DEFAULT	DESCRIPTION
	0	AIF1_DACD AT_SRC	0	AIF1 DACDAT Source select 0 = DACDAT1 1 = GPIO8/DACDAT3 Note that, for selection 1, the GPIO8 pin must be configured as DACDAT3.

Table 108 AIF3 Signal Path Configuration

AIF3 - BCLK AND LRCLK CONTROL

The GPIO10 pin supports the LRCLK3 function. When configured as LRCLK3, this pin outputs the LRCLK signal from AIF1 or AIF2. The applicable AIF source is determined automatically as defined in Table 109. Note that the LRCLK3 signal is also controlled by the logic illustrated in Figure 63 (AIF1) or Figure 66 (AIF2), depending on the selected AIF source.

The GPIO11 pin supports the BCLK3 function. When configured as BCLK3, this pin outputs the BCLK signal from AIF1 or AIF2. The applicable AIF source is determined automatically as defined in Table 109. Note that the BCLK3 signal is also controlled by the logic illustrated in Figure 63 (AIF1) or Figure 66 (AIF2), depending on the selected AIF source.

CONDITION	DESCRIPTION
AIF1_DACDAT_SRC = 1 (DACDAT3 selected as AIF1 data input) or AIF3_ADCDAT_SRC[1:0] = 00 (AIF1 data output selected on ADCDAT3)	AIF1 selected as BCLK3 / LRCLK3 source
All other conditions	AIF2 selected as BCLK3 / LRCLK3 source

Table 109 BCLK3 / LRCLK3 Configuration

The LRCLK3 output can be inverted by setting the AIF3_LRCLK_INV register. Note that AIF3 operates in Master mode only.

REGISTER ADDRESS	BIT	LABEL	DEFAULT	DESCRIPTION
R800 (0320h) AIF3 Control (1)	7	AIF3_LRCL K_INV	0	Right, left and I ² S modes – LRCLK3 polarity 0 = normal LRCLK3 polarity 1 = invert LRCLK3 polarity DSP Mode – mode A/B select 0 = MSB is available on 2nd BCLK3 rising edge after LRCLK3 rising edge (mode A) 1 = MSB is available on 1st BCLK3 rising edge after LRCLK3 rising edge (mode B)

Table 110 AIF3 LRCLK Control

AIF3 - DIGITAL AUDIO DATA CONTROL

The register bits controlling the AIF3 Mono PCM interface are described in Table 111.

Note that these registers control the AIF3 Mono PCM interface only; they are not applicable to the ADCDAT3 and DACDAT3 signal paths when these pins are selected as alternate inputs to the AIF1 or AIF2 interfaces.

The audio data format for AIF3 is set the same as AIF2; this is controlled using the AIF2_FMT register, as described in see Table 103.

In DSP mode, the AIF3 Mono channel MSB is available on either the 1st (mode B) or 2nd (mode A) rising edge of BCLK following a rising edge of LRCLK. The applicable DSP mode is selected using the AIF3_LRCLK_INV bit, as described in Table 110.

In Left justified, Right justified and I2S modes, the AIF3 Mono interface data is transmitted and received in the Left channel data bits of the ADCDAT3 and DACDAT3 channels.

A digital gain function is available at the audio interface input path to boost the DAC volume when a small signal is received on DACDAT3. This is controlled using the AIF3DAC_BOOST register. To prevent clipping, this function should not be used when the boosted data is expected to be greater than 0dBFS.

REGISTER ADDRESS	BIT	LABEL	DEFAULT	DESCRIPTION
R800 (0320h) AIF3 Control (1)	6:5	AIF3_WL [1:0]	10	AIF3 Digital Audio Interface Word Length 00 = 16 bits 01 = 20 bits 10 = 24 bits 11 = 32 bits Note - 8-bit modes can be selected using the "Companding" control bits. Note that this controls the AIF3 Mono PCM interface path only; it does not affect AIF3 inputs/outputs routed to AIF1 or AIF2.
R801 (0321h) AIF3 Control (2)	11:10	AIF3DAC_BOOST [1:0]	00	AIF3 Input Path Boost 00 = 0dB 01 = +6dB (input must not exceed -6dBFS) 10 = +12dB (input must not exceed -12dBFS) 11 = +18dB (input must not exceed -18dBFS) Note that this controls the AIF3 Mono PCM interface path only; it does not affect DACDAT3 input to AIF1 or AIF2.
R802 (0322h) AIF3DAC Data	0	AIF3DAC_DATA_INV	0	AIF3 Receive Data Invert 0 = Not inverted 1 = Inverted Note that this controls the AIF3 Mono PCM interface path only; it does not affect DACDAT3 input to AIF1 or AIF2.
R803 (0323h) AIF3ADC Data	0	AIF3ADC_DATA_INV	0	AIF3 Transmit Data Invert 0 = Not inverted 1 = Inverted Note that this controls the AIF3 Mono PCM interface path only; it does not affect ADCDAT3 output from AIF1 or AIF2.

Table 111 AIF3 Digital Audio Data Control

AIF3 - COMPANDING

The WM8958 supports A-law and μ -law companding on both transmit (ADC) and receive (DAC) sides of AIF3. This is configured using the register bits described in Table 112.

Note that these registers control the AIF3 Mono PCM interface only; they are not applicable to the ADCDAT3 and DACDAT3 signal paths when these pins are selected as alternate inputs to the AIF1 or AIF2 interfaces.

For more details on Companding, see the Audio Interface AIF1 description above.

REGISTER ADDRESS	BIT	LABEL	DEFAULT	DESCRIPTION
R801 (0321h) AIF3 Control (2)	4	AIF3DAC_C OMP	0	AIF3 Receive Companding Enable 0 = Disabled 1 = Enabled Note that this controls the AIF3 Mono PCM interface path only; it does not affect DACDAT3 input to AIF1 or AIF2.
	3	AIF3DAC_C OMPMODE	0	AIF3 Receive Companding Type 0 = μ -law 1 = A-law Note that this controls the AIF3 Mono PCM interface path only; it does not affect DACDAT3 input to AIF1 or AIF2.
	2	AIF3ADC_C OMP	0	AIF3 Transmit Companding Enable 0 = Disabled 1 = Enabled Note that this controls the AIF3 Mono PCM interface path only; it does not affect ADCDAT3 output from AIF1 or AIF2.
	1	AIF3ADC_C OMPMODE	0	AIF3 Transmit Companding Type 0 = μ -law 1 = A-law Note that this controls the AIF3 Mono PCM interface path only; it does not affect ADCDAT3 output from AIF1 or AIF2.

Table 112 AIF3 Companding

AIF3 - LOOPBACK

The AIF3 interface can provide a Loopback option. When the AIF3_LOOPBACK bit is set, then AIF3 Mono PCM output is routed to the AIF3 Mono PCM input. The normal input (DACDAT3) is not used when AIF3 Loopback is enabled.

REGISTER ADDRESS	BIT	LABEL	DEFAULT	DESCRIPTION
R801 (0321h) AIF3 Control (2)	0	AIF3_LOOP BACK	0	AIF3 Digital Loopback Function 0 = No loopback 1 = Loopback enabled (AIF3 Mono PCM data output is directly input to AIF3 Mono PCM data input).

Table 113 AIF3 Loopback

CLOCKING AND SAMPLE RATES

The WM8958 requires a clock for each of the Digital Audio Interfaces (AIF1 and AIF2). These may be derived from a common clock reference, or from independent references. Under typical clocking configurations, many commonly-used audio sample rates can be derived directly from the external reference; for additional flexibility, the WM8958 incorporates two Frequency Locked Loop (FLL) circuits to perform frequency conversion and filtering.

External clock signals may be connected via MCLK1 and MCLK2. In AIF Slave modes, the BCLK or LRCLK signals may be used as a reference for the AIF clocks.

The WM8958 performs stereo full-duplex sample rate conversion between the audio interfaces AIF1 and AIF2, enabling digital audio to be routed between the interfaces, and asynchronous audio data to be mixed together. See "Sample Rate Conversion" for further details.

In AIF Slave modes, it is important to ensure the applicable AIF clock (AIF1CLK or AIF2CLK) is synchronised with the associated external LRCLK. This can be achieved by selecting an MCLK input that is derived from the same reference as the LRCLK, or can be achieved by selecting the external BCLK or LRCLK signals as a reference input to one of the FLLs, as a source for the AIF clock.

If the AIF clock is not synchronised with the LRCLK, then clicks arising from dropped or repeated audio samples will occur, due to the inherent tolerances of multiple, asynchronous, system clocks. See "Applications Information" for further details on valid clocking configurations.

Clocking for the Audio Interfaces is provided by AIF1CLK and AIF2CLK for AIF1 and AIF2 respectively. An additional internal clock, SYSCLK is derived from either AIF1CLK or AIF2CLK in order to support the DSP core functions, Charge Pump, Class D switching amplifier, DC servo control, Control Write Sequencer and other internal functions. A further clock, DSP2CLK, is derived from either AIF1CLK or AIF2CLK in order to support the Multiband Compressor (MBC) function.

The following operating limits must be observed when configuring the WM8958 clocks. Failure to observe these limits will result in degraded performance and/or incorrect system functionality. Latency in the WM8958 signal paths is reduced at high SYSCLK frequencies; power consumption is reduced at low SYSCLK frequencies.

- $\text{SYSCLK} \leq 12.5\text{MHz}$
- $\text{SYSCLK} \geq 4.096\text{MHz}$
- $\text{SYSCLK} \geq 256 \times f_s$ (where f_s = fastest audio sample rate in use)

- $\text{AIF1CLK} \leq 12.5\text{MHz}$
- $\text{AIF1CLK} \geq 256 \times \text{AIF1 sample rate (AIF1_SR)}$

- $\text{AIF2CLK} \leq 12.5\text{MHz}$
- $\text{AIF2CLK} \geq 256 \times \text{AIF2 sample rate (AIF2_SR)}$

- $\text{DSP2CLK} \geq 256 \times \text{AIFn sample rate (when MBC is enabled on the AIFn playback path)}$

Note that, if $\text{DAC_OSR128} = 0$ and $\text{ADC_OSR128} = 0$, then a slower SYSCLK frequency is possible; in this case, the requirement is $\text{SYSCLK} \geq 2.048\text{MHz}$.

Note that, under specific operating conditions, clocking ratios of $128 \times f_s$ and $192 \times f_s$ are possible; this is described in the "Digital to Analogue Converter (DAC)" section.

The SYSCLK frequency must be $\geq 256 \times f_s$, (where f_s is the faster rate of AIF1_SR or AIF2_SR). The SYSCLK frequency is derived from AIF1CLK or AIF2CLK, as selected by the SYSCLK_SRC register (see Table 118).

Note that the bandwidth of the digital audio mixing paths will be determined by the sample rate of whichever AIF is selected as the SYSCLK source. When using only one audio interface, the active interface should be selected as the SYSCLK source. For best audio performance when using AIF1 and AIF2 simultaneously, the SYSCLK source must select the AIF with the highest sample rate (AIF_n_SR).

The AIF_nCLK / fs ratio is the ratio of AIF_nCLK to the AIF_n sample rate, where 'n' identifies the applicable audio interface AIF1 or AIF2. The AIF clocking ratio and sample rate are set by the AIF_nCLK_RATE and AIF_n_SR register fields, defined in Table 115 and Table 117.

Note that, in the case of mixed input/output path sample rates on either interface, then AIF_nCLK_RATE and AIF_n_SR are set according to the higher of the two sample rates.

The clocking configuration for AIF1CLK, AIF2CLK, SYSCLK and DSP2CLK is illustrated in Figure 68. The SYSCLK_SRC register is defined in Table 118.

The WM8958 provides integrated pull-up and pull-down resistors on the MCLK1 and MCLK2 pins. This provides a flexible capability for interfacing with other devices. This is configured as described in Table 118. Note that if the Pull-up and Pull-down are both enabled for any pin, then the pull-up and pull-down will be disabled.

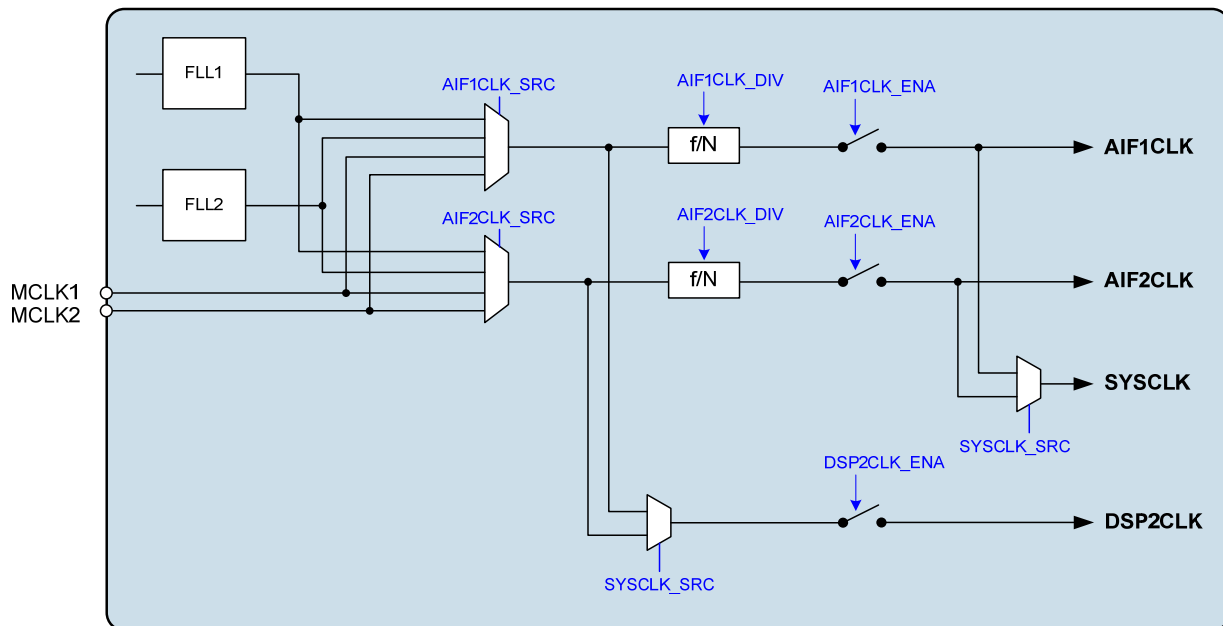

Figure 68 Audio Interface Clock Control

AIF1CLK ENABLE

The AIF1CLK_SRC register is used to select the AIF1CLK source. The source may be MCLK1, MCLK2, FLL1 or FLL2. If either of the Frequency Locked Loops is selected as the source, then the FLL(s) must be enabled and configured as described later.

The AIF1CLK clock may be adjusted by the AIF1CLK_DIV divider, which provides a divide-by-two option. The selected source may also be inverted by setting the AIF1CLK_INV bit.

The maximum AIF1CLK frequency is specified in the "Electrical Characteristics" section. Note that, when AIF1CLK_DIV = 1, the maximum frequency limit applies to the divided-down AIF1CLK frequency.

The AIF1CLK is enabled by the register bit AIF1CLK_ENA. This bit should be set to 0 when reconfiguring the clock sources. It is not recommended to change AIF1CLK_SRC while the AIF1CLK_ENA bit is set.

REGISTER ADDRESS	BIT	LABEL	DEFAULT	DESCRIPTION
R512 (0200h) AIF 1 Clocking (1)	4:3	AIF1CLK_SR C	00	AIF1CLK Source Select 00 = MCLK1 01 = MCLK2 10 = FLL1 11 = FLL2
	2	AIF1CLK_INV	0	AIF1CLK Invert 0 = AIF1CLK not inverted 1 = AIF1CLK inverted
	1	AIF1CLK_DIV	0	AIF1CLK Divider 0 = AIF1CLK 1 = AIF1CLK / 2
	0	AIF1CLK_EN A	0	AIF1CLK Enable 0 = Disabled 1 = Enabled

Table 114 AIF1CLK Enable

AIF1 CLOCKING CONFIGURATION

The WM8958 supports a wide range of standard audio sample rates from 8kHz to 96kHz. The AIF1 clocking configuration is selected using 4 control fields, which are set according to the required AIF digital audio sample rate, and the ADC/DAC clocking rate.

The AIF1_SR register is set according to the AIF1 sample rate. Note that 88.2kHz and 96kHz modes are supported for AIF1 input (DAC playback) only.

The AIF1CLK_RATE register is set according to the ratio of AIF1CLK to the AIF1 sample rate. Note that there are some restrictions on the supported clocking ratios, depending on the selected sample rate and operating conditions. The supported configurations are detailed in the "Digital Microphone Interface", "Analogue to Digital Converter (ADC)" and "Digital to Analogue Converter (DAC)" sections, according to each applicable function.

The audio interface can support different sample rates for the input data (DAC path) and output data (ADC path) simultaneously. In this case, the AIF1_SR and AIF1CLK_RATE fields should be set according to the faster of the two sample rates.

When different sample rates are used for input data (DAC path) and output data (ADC path), the clocking of the slower path is set using AIF1DAC_DIV (if the AIF input path has the slower sample rate) or AIF1ADC_DIV (if the AIF output path has the slower sample rate). The appropriate divider is set according to the ratio of the two sample rates.

For example, if AIF1 input uses 48kHz sample rate, and AIF1 output uses 8kHz, then AIF1ADC_DIV should be set to 110b (divide by 6).

Note that the audio interface cannot support every possible combination of input and output sample rate simultaneously, but only where the ratio of the sample rates matches the available AIF1ADC_DIV or AIF1DAC_DIV divider settings.

Note that the WM8958 performs sample rate conversion, where necessary, to provide digital mixing and interconnectivity between the Audio Interfaces and the DSP Core functions. One stereo Sample Rate Converter (SRC) is provided for audio input; a second stereo SRC is provided for audio output. Each SRC is automatically configured on AIF1 or AIF2, depending on the selected Clocking and Sample Rate settings. The WM8958 cannot support configurations that would require SRC on the input or output paths of both interfaces simultaneously. See "Sample Rate Conversion" for further details.

REGISTER ADDRESS	BIT	LABEL	DEFAULT	DESCRIPTION
R513 (0201h) AIF 1 Clocking (2)	5:3	AIF1DAC_DIV	000	<p>Selects the AIF1 input path sample rate relative to the AIF1 output path sample rate.</p> <p>This field should only be changed from default in modes where the AIF1 input path sample rate is slower than the AIF1 output path sample rate.</p> <p>000 = Divide by 1 001 = Divide by 1.5 010 = Divide by 2 011 = Divide by 3 100 = Divide by 4 101 = Divide by 5.5 110 = Divide by 6 111 = Reserved</p>
	2:0	AIF1ADC_DIV	000	<p>Selects the AIF1 output path sample rate relative to the AIF1 input path sample rate.</p> <p>This field should only be changed from default in modes where the AIF1 output path sample rate is slower than the AIF1 input path sample rate.</p> <p>000 = Divide by 1 001 = Divide by 1.5 010 = Divide by 2 011 = Divide by 3 100 = Divide by 4 101 = Divide by 5.5 110 = Divide by 6 111 = Reserved</p>
R528 (0210h) AIF1 Rate	7:4	AIF1_SR	1000	<p>Selects the AIF1 Sample Rate (fs)</p> <p>0000 = 8kHz 0001 = 11.025kHz 0010 = 12kHz 0011 = 16kHz 0100 = 22.05kHz 0101 = 24kHz 0110 = 32kHz 0111 = 44.1kHz 1000 = 48kHz 1001 = 88.2kHz 1010 = 96kHz</p> <p>All other codes = Reserved</p> <p>Note that 88.2kHz and 96kHz modes are supported for AIF1 input (DAC playback) only.</p>
	3:0	AIF1CLK_RAT E	0011	<p>Selects the AIF1CLK / fs ratio</p> <p>0000 = Reserved 0001 = 128 0010 = 192 0011 = 256 0100 = 384 0101 = 512 0110 = 768 0111 = 1024 1000 = 1408 1001 = 1536</p> <p>All other codes = Reserved</p>

Table 115 AIF1 Clocking Configuration

AIF2CLK ENABLE

The AIF2CLK_SRC register is used to select the AIF2CLK source. The source may be MCLK1, MCLK2, FLL1 or FLL2. If either of the Frequency Locked Loops is selected as the source, then the FLL(s) must be enabled and configured as described later.

The AIF2CLK clock may be adjusted by the AIF2CLK_DIV divider, which provides a divide-by-two option. The selected source may also be inverted by setting the AIF2CLK_INV bit.

The maximum AIF2CLK frequency is specified in the “Electrical Characteristics” section. Note that, when AIF2CLK_DIV = 1, the maximum frequency limit applies to the divided-down AIF2CLK frequency.

The AIF2CLK is enabled by the register bit AIF2CLK_ENA. This bit should be set to 0 when reconfiguring the clock sources. It is not recommended to change AIF2CLK_SRC while the AIF2CLK_ENA bit is set.

REGISTER ADDRESS	BIT	LABEL	DEFAULT	DESCRIPTION
R516 (0204h) AIF 2 Clocking (1)	4:3	AIF2CLK_SRC	00	AIF2CLK Source Select 00 = MCLK1 01 = MCLK2 10 = FLL1 11 = FLL2
	2	AIF2CLK_INV	0	AIF2CLK Invert 0 = AIF2CLK not inverted 1 = AIF2CLK inverted
	1	AIF2CLK_DIV	0	AIF2CLK Divider 0 = AIF2CLK 1 = AIF2CLK / 2
	0	AIF2CLK_ENA	0	AIF2CLK Enable 0 = Disabled 1 = Enabled

Table 116 AIF2CLK Enable

AIF2 CLOCKING CONFIGURATION

The WM8958 supports a wide range of standard audio sample rates from 8kHz to 96kHz. The AIF2 clocking configuration is selected using 4 control fields, which are set according to the required AIF digital audio sample rate, and the ADC/DAC clocking rate.

The AIF2_SR register is set according to the AIF2 sample rate. Note that 88.2kHz and 96kHz modes are supported for AIF2 input (DAC playback) only.

The AIF2CLK_RATE register is set according to the ratio of AIF2CLK to the AIF2 sample rate. Note that there are some restrictions on the supported clocking ratios, depending on the selected sample rate and operating conditions. The supported configurations are detailed in the “Digital Microphone Interface”, “Analogue to Digital Converter (ADC)” and “Digital to Analogue Converter (DAC)” sections, according to each applicable function.

The audio interface can support different sample rates for the input data (DAC path) and output data (ADC path) simultaneously. In this case, the AIF2_SR and AIF2CLK_RATE fields should be set according to the faster of the two sample rates.

When different sample rates are used for input data (DAC path) and output data (ADC path), the clocking of the slower path is set using AIF2DAC_DIV (if the AIF input path has the slower sample rate) or AIF2ADC_DIV (if the AIF output path has the slower sample rate). The appropriate divider is set according to the ratio of the two sample rates.

For example, if AIF2 input uses 48kHz sample rate, and AIF2 output uses 8kHz, then AIF2ADC_DIV should be set to 110b (divide by 6).

Note that the audio interface cannot support every possible combination of input and output sample rate simultaneously, but only where the ratio of the sample rates matches the available AIF2ADC_DIV or AIF2DAC_DIV divider settings.

Note that the WM8958 performs sample rate conversion, where necessary, to provide digital mixing and interconnectivity between the Audio Interfaces and the DSP Core functions. One stereo Sample Rate Converter (SRC) is provided for audio input; a second stereo SRC is provided for audio output. Each SRC is automatically configured on AIF1 or AIF2, depending on the selected Clocking and Sample Rate settings. The WM8958 cannot support configurations that would require SRC on the input or output paths of both interfaces simultaneously. See "Sample Rate Conversion" for further details.

REGISTER ADDRESS	BIT	LABEL	DEFAULT	DESCRIPTION
R517 (0205h) AIF 2 Clocking (2)	5:3	AIF2DAC_DIV	000	Selects the AIF2 input path sample rate relative to the AIF2 output path sample rate. This field should only be changed from default in modes where the AIF2 input path sample rate is slower than the AIF2 output path sample rate. 000 = Divide by 1 001 = Divide by 1.5 010 = Divide by 2 011 = Divide by 3 100 = Divide by 4 101 = Divide by 5.5 110 = Divide by 6 111 = Reserved
	2:0	AIF2ADC_DIV	000	Selects the AIF2 output path sample rate relative to the AIF2 input path sample rate. This field should only be changed from default in modes where the AIF2 output path sample rate is slower than the AIF2 input path sample rate. 000 = Divide by 1 001 = Divide by 1.5 010 = Divide by 2 011 = Divide by 3 100 = Divide by 4 101 = Divide by 5.5 110 = Divide by 6 111 = Reserved
R529 (0211h) AIF2 Rate	7:4	AIF2_SR	1000	Selects the AIF2 Sample Rate (fs) 0000 = 8kHz 0001 = 11.025kHz 0010 = 12kHz 0011 = 16kHz 0100 = 22.05kHz 0101 = 24kHz 0110 = 32kHz 0111 = 44.1kHz 1000 = 48kHz 1001 = 88.2kHz 1010 = 96kHz All other codes = Reserved Note that 88.2kHz and 96kHz modes are supported for AIF2 input (DAC playback) only.

REGISTER ADDRESS	BIT	LABEL	DEFAULT	DESCRIPTION
	3:0	AIF2CLK_RATE	0011	Selects the AIF2CLK / fs ratio 0000 = Reserved 0001 = 128 0010 = 192 0011 = 256 0100 = 384 0101 = 512 0110 = 768 0111 = 1024 1000 = 1408 1001 = 1536 All other codes = Reserved

Table 117 AIF2 Clocking Configuration

MISCELLANEOUS CLOCK CONTROLS

SYSCLK provides clocking for many of the WM8958 functions. SYSCLK clock is required to support DSP Core functions and also the Charge Pump, Class D switching amplifier, DC servo control, Control Write Sequencer and other internal functions.

The SYSCLK_SRC register is used to select the SYSCLK source. The source may be AIF1CLK or AIF2CLK, as illustrated in Figure 69. Note that the bandwidth of the digital audio mixing paths will be determined by the sample rate of whichever AIF is selected as the SYSCLK source. When using only one audio interface, the active interface should be selected as the SYSCLK source. For best audio performance when using AIF1 and AIF2 simultaneously, the SYSCLK source must select the AIF with the highest sample rate (AIFn_SR).

The SYSCLK_SRC register is also used to select the DSP2CLK source; the DSP2CLK clock is required for the Multiband Compressor (MBC) function. The MBC can be enabled on the AIF1 or AIF2 input paths, regardless of the SYSCLK_SRC setting, provided that the minimum clocking requirement for the MBC is satisfied. See "Multiband Compressor" for further details.

The MBC clocking is enabled using the DSP2CLK_ENA bit, as illustrated in Figure 69. See "Multiband Compressor" for further details of the MBC clocking requirements.

The AIF1 DSP processing clock is derived from SYSCLK, and enabled by AIF1DSPCLK_ENA.

The AIF2 DSP processing clock is derived from SYSCLK, and enabled by AIF2DSPCLK_ENA.

The clocking of the WM8958 ADC, DAC, digital mixer and digital microphone functions is enabled by setting SYSDSPCLK_ENA. See "Digital Microphone Interface" for details of the DMICCLK frequency.

Two modes of ADC / Digital Microphone operation can be selected using the ADC_OSR128 bit. This bit is enabled by default, giving best audio performance. De-selecting this bit provides a low power alternative setting.

A high performance mode of DAC operation can be selected by setting the DAC_OSR128 bit. When the DAC_OSR128 bit is set, the audio performance is improved, but power consumption is also increased.

A clock is required for the Charge Pump circuit when the ground-referenced headphone outputs (HPOUT1L and HPOUT1R) are enabled. The Charge Pump clock is derived from SYSCLK whenever the Charge Pump is enabled. The Charge Pump clock division is configured automatically.

A clock is required for the Class D speaker driver circuit when the speaker outputs (SPKOUTL and SPKOUTR) are enabled. The Class D clock is derived from SYSCLK whenever these outputs are enabled in Class D mode. The Class D clock division is configured automatically. See "Analogue Outputs" for details of the Class D switching frequency.

A clock output (OPCLK) derived from SYSCLK may be output on a GPIO pin. This clock is enabled by register bit OPCLK_ENA, and its frequency of this clock is controlled by OPCLK_DIV. See "General Purpose Input/Output" to configure a GPIO pin for this function.

A slow clock (TOCLK) is derived internally in order to control volume update timeouts when the zero-cross option is selected. This clock is enabled by register bit TOCLK_ENA, and its frequency is controlled by TOCLK_DIV.

A de-bounce control is provided for GPIO inputs and for other functions that may be selected as GPIO outputs. The de-bounced clock frequency is controlled by DBCLK_DIV.

The WM8958 generates a 256kHz clock for internal functions; TOCLK and DBCLK are derived from this 256kHz clock. In order to generate this clock correctly when SYSCLK_SRC = 0, valid settings are required for AIF1_SR and AIF1CLK_RATE. To generate this clock correctly when SYSCLK_SRC = 1, valid settings are required for AIF2_SR and AIF2CLK_RATE.

The WM8958 Clocking is illustrated in Figure 69.

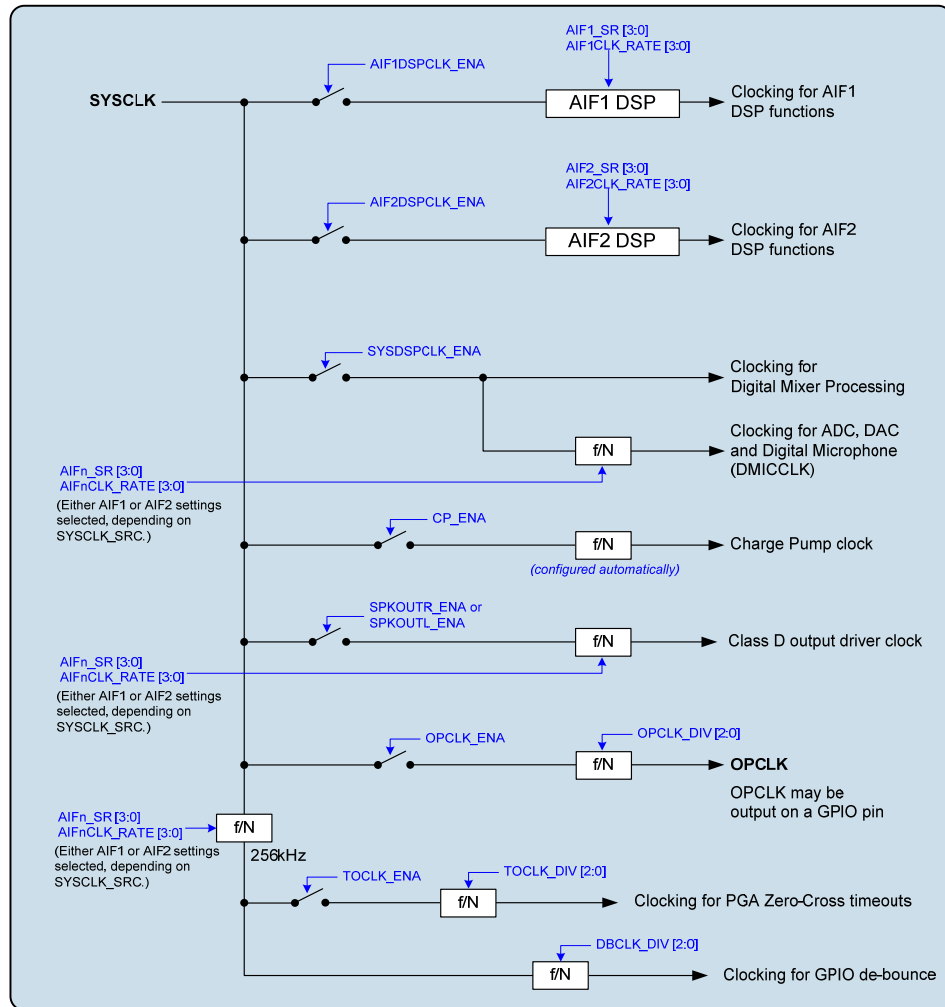

Figure 69 System Clocking

REGISTER ADDRESS	BIT	LABEL	DEFAULT	DESCRIPTION
R2 (0002h) Power Management (2)	11	OPCLK_ENA	0	GPIO Clock Output (OPCLK) Enable 0 = Disabled 1 = Enabled
R520 (0208h) Clocking (1)	14	DSP2CLK_ENA	0	MBC Processor Clock Enable 0 = Disabled 1 = Enabled
	4	TOCLK_ENA	0	Slow Clock (TOCLK) Enable 0 = Disabled 1 = Enabled This clock is required for zero-cross timeout.
	3	AIF1DSPCLK_ENA	0	AIF1 Processing Clock Enable 0 = Disabled 1 = Enabled
	2	AIF2DSPCLK_ENA	0	AIF2 Processing Clock Enable 0 = Disabled 1 = Enabled
	1	SYDSPCLK_ENA	0	Digital Mixing Processor Clock Enable 0 = Disabled 1 = Enabled
	0	SYSCLK_SRC	0	SYSCLK Source Select 0 = AIF1CLK 1 = AIF2CLK
R521 (0209h) Clocking (2)	10:8	TOCLK_DIV	000	Slow Clock (TOCLK) Divider (Sets TOCLK rate relative to 256kHz.) 000 = Divide by 256 (1kHz) 001 = Divide by 512 (500Hz) 010 = Divide by 1024 (250Hz) 011 = Divide by 2048 (125Hz) 100 = Divide by 4096 (62.5Hz) 101 = Divide by 8192 (31.2Hz) 110 = Divide by 16384 (15.6Hz) 111 = Divide by 32768 (7.8Hz)
	6:4	DBCLK_DIV	000	De-bounce Clock (DBCLK) Divider (Sets DBCLK rate relative to 256kHz.) 000 = Divide by 256 (1kHz) 001 = Divide by 2048 (125Hz) 010 = Divide by 4096 (62.5Hz) 011 = Divide by 8192 (31.2Hz) 100 = Divide by 16384 (15.6Hz) 101 = Divide by 32768 (7.8Hz) 110 = Divide by 65536 (3.9Hz) 111 = Divide by 131072 (1.95Hz)

REGISTER ADDRESS	BIT	LABEL	DEFAULT	DESCRIPTION
	2:0	OPCLK_DIV	000	GPIO Output Clock (OPCLK) Divider 0000 = SYSCLK 0001 = SYSCLK / 2 0010 = SYSCLK / 3 0011 = SYSCLK / 4 0100 = SYSCLK / 5.5 0101 = SYSCLK / 6 0110 = SYSCLK / 8 0111 = SYSCLK / 12 1000 = SYSCLK / 16 1001 to 1111 = Reserved
R1568 (0620h) Oversampling	1	ADC_OS128	1	ADC / Digital Microphone Oversample Rate Select 0 = Low Power 1 = High Performance
	0	DAC_OS128	0	DAC Oversample Rate Select 0 = Low Power 1 = High Performance
R1793 (0701h) Pull Control (MCLK2)	14	MCLK2_PU	0	MCLK2 Pull-up enable 0 = Disabled 1 = Enabled
	13	MCLK2_PD	1	MCLK2 Pull-down enable 0 = Disabled 1 = Enabled
R1824 (0720h) Pull Control (1)	7	MCLK1_PU	0	MCLK1 Pull-up enable 0 = Disabled 1 = Enabled
	6	MCLK1_PD	0	MCLK1 Pull-down enable 0 = Disabled 1 = Enabled

Table 118 System Clocking

BCLK AND LRCLK CONTROL

The digital audio interfaces (AIF1 and AIF2) use BCLK and LRCLK signals for synchronisation. In master mode, these are output signals, generated by the WM8958. In slave mode, these are input signals to the WM8958. It is also possible to support mixed master/slave operation.

The BCLK and LRCLK signals are controlled as illustrated in Figure 70. See the "Digital Audio Interface Control" section for further details of the relevant control registers.

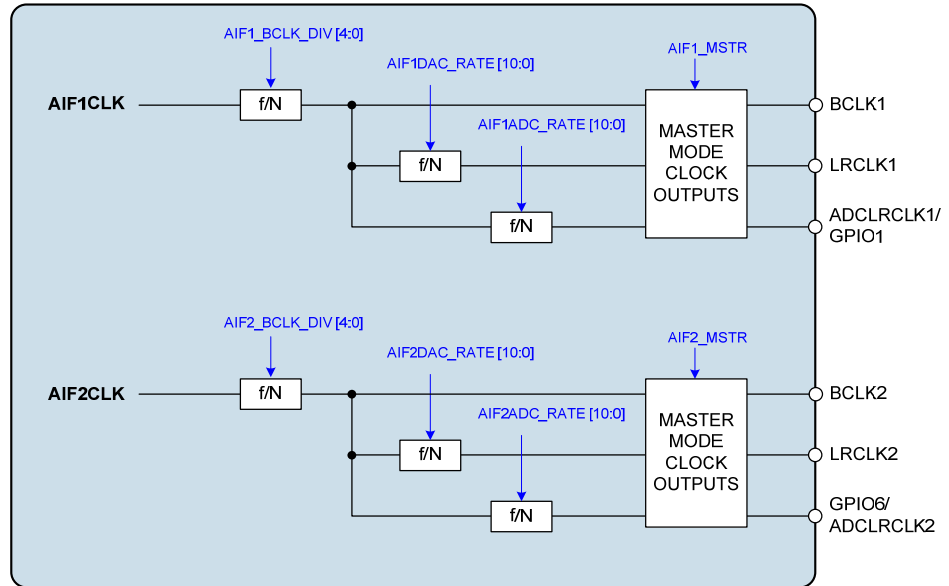

Figure 70 BCLK and LRCLK Control

CONTROL INTERFACE CLOCKING

Register map access is possible with or without a system clock. Clocking is provided from SYSCLK; the SYSCLK_SRC register selects either AIF1CLK or AIF2CLK as the applicable SYSCLK source.

When AIF1CLK is the SYSCLK source (ie. SYSCLK_SRC = 0), and AIF1CLK_ENA = 1, then an active clock source for AIF1CLK must be present for control interface clocking. If the AIF1CLK source is stopped, then AIF1CLK_ENA must be set to 0 for control register access.

When AIF2CLK is the SYSCLK source (ie. SYSCLK_SRC = 1), and AIF2CLK_ENA = 1, then an active clock source for AIF2CLK must be present for control interface clocking. If the AIF2CLK source is stopped, then AIF2CLK_ENA must be set to 0 for control register access.

FREQUENCY LOCKED LOOP (FLL)

Two integrated FLLs are provided to support the clocking requirements of the WM8958. These can be enabled and configured independently according to the available reference clocks and the application requirements. The reference clock may be a high frequency (eg. 12.288MHz) or low frequency (eg. 32.768kHz).

The FLL is tolerant of jitter and may be used to generate a stable AIF clock from a less stable input reference. The FLL characteristics are summarised in "Electrical Characteristics". Note that the FLL can be used to generate a free-running clock in the absence of an external reference source. This is described in the "Free-Running FLL Clock" section below.

The input reference for FLL1 is selected using FLL1_REFCLK_SRC. The available options are MCLK1, MCLK2, BCLK1 or LRCLK1. The input reference for FLL2 is selected using FLL2_REFCLK_SRC. The available options are MCLK1, MCLK2, BCLK2 or LRCLK2.

The FLLs can be bypassed using the FLL1_BYP or FLL2_BYP registers. This allows the BCLK_n clock to be used as the AIF_nCLK reference, without enabling the respective FLL.

The FLL input reference and bypass configurations are illustrated in Figure 71.

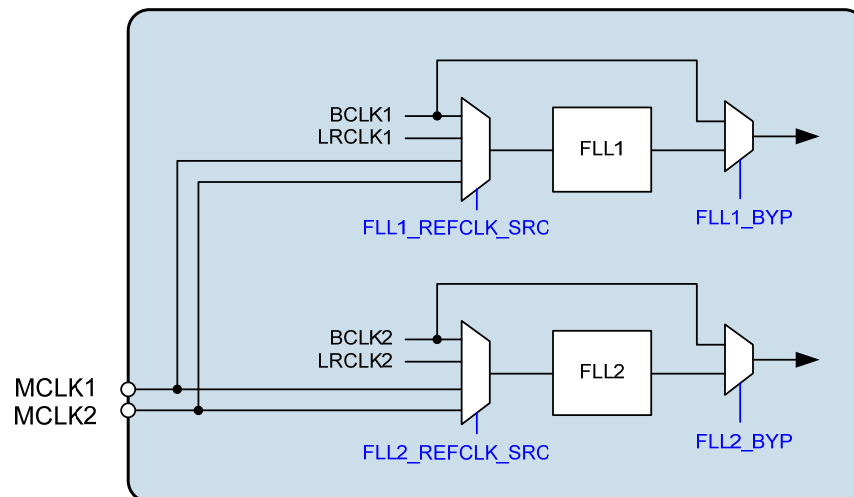

Figure 71 FLL Input Reference Selection

The following description is applicable to FLL1 and FLL2. The associated register control fields are described in Table 121 for FLL1 and Table 122 for FLL2.

The FLL control registers are illustrated in Figure 72.

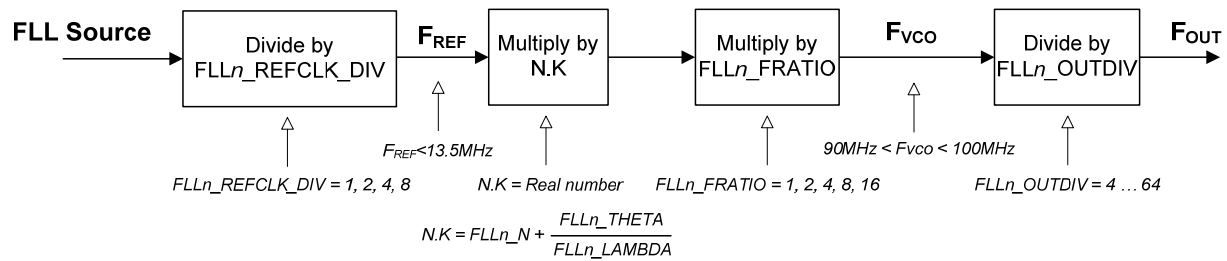

Figure 72 FLL Configuration

The FLL is enabled using the $FLLn_ENA$ register bit (where $n = 1$ for FLL1 and $n = 2$ for FLL2). Note that the other FLL registers should be configured before enabling the FLL; the $FLLn_ENA$ register bit should be set as the final step of the $FLLn$ enable sequence.

When changing FLL settings, it is recommended that the digital circuit be disabled via $FLLn_ENA$ and then re-enabled after the other register settings have been updated. When changing the input reference frequency F_{REF} , it is recommended that the FLL be reset by setting $FLLn_ENA$ to 0.

The field $FLLn_REFCLK_DIV$ provides the option to divide the input reference (MCLK, BCLK or LRCLK) by 1, 2, 4 or 8. This field should be set to bring the reference down to 13.5MHz or below. For best performance, it is recommended that the highest possible frequency - within the 13.5MHz limit - should be selected.

The FLL output frequency is directly determined from $FLLn_FRATIO$, $FLLn_OUTDIV$ and the real number represented by $N.K$.

The integer value, N , is held in the $FLLn_N$ register field. The fractional portion, K , is determined by the ratio $FLLn_THETA / FLLn_LAMBDA$.

Note that the $FLLn_EFS_ENA$ register bit must be enabled in fractional mode (ie. whenever $FLLn_THETA > 0$).

The FLL output frequency is generated according to the following equation:

$$F_{OUT} = (F_{VCO} / FLLn_OUTDIV)$$

The FLL operating frequency, F_{VCO} is set according to the following equation:

$$F_{VCO} = (F_{REF} \times N.K \times FLLn_FRATIO)$$

F_{REF} is the input frequency, as determined by $FLLn_REFCLK_DIV$.

F_{VCO} must be in the range 90-100 MHz. Frequencies outside this range cannot be supported.

Note that the output frequencies that do not lie within the ranges quoted above cannot be guaranteed across the full range of device operating conditions.

In order to follow the above requirements for F_{VCO} , the value of $FLLn_OUTDIV$ should be selected according to the desired output F_{OUT} . The divider, $FLLn_OUTDIV$, must be set so that F_{VCO} is in the range 90-100MHz. The available divisions are integers from 4 to 64. Some typical settings of $FLLn_OUTDIV$ are noted in Table 119.

OUTPUT FREQUENCY F_{OUT}	$FLLn_OUTDIV$
1.875 MHz - 2.0833 MHz	101111 (divide by 48)
2.8125 MHz - 3.125 MHz	011111 (divide by 32)
3.75 MHz - 4.1667 MHz	010111 (divide by 24)
5.625 MHz - 6.25 MHz	001111 (divide by 16)
11.25 MHz - 12.5 MHz	000111 (divide by 8)
18 MHz - 20 MHz	000100 (divide by 5)
22.5 MHz - 25 MHz	000011 (divide by 4)

Table 119 Selection of $FLLn_OUTDIV$

The value of $FLLn_FRATIO$ should be selected as described in Table 120.

REFERENCE FREQUENCY F_{REF}	$FLLn_FRATIO$
1MHz - 13.5MHz	0h (divide by 1)
256kHz - 1MHz	1h (divide by 2)
128kHz - 256kHz	2h (divide by 4)
64kHz - 128kHz	3h (divide by 8)
Less than 64kHz	4h (divide by 16)

Table 120 Selection of $FLLn_FRATIO$

In order to determine the remaining FLL parameters, the FLL operating frequency, F_{VCO} , must be calculated, as given by the following equation:

$$F_{VCO} = (F_{OUT} \times FLLn_OUTDIV)$$

The value of N.K can then be determined as follows:

$$N.K = F_{VCO} / (FLLn_FRATIO \times F_{REF})$$

Note that, in the above equations:

$FLLn_OUTDIV$ is the F_{OUT} clock ratio.

F_{REF} is the input frequency, after division by FLL_REFCLK_DIV , where applicable.

$FLLn_FRATIO$ is the F_{VCO} clock ratio (1, 2, 4, 8 or 16).

The value of N is held in the $FLLn_N$ register field.

The value of K is determined by the ratio $FLLn_THETA / FLLn_LAMBDA$.

The $FLLn_N$, $FLLn_THETA$ and $FLLn_LAMBDA$ fields are all coded as integers (LSB = 1).

In Fractional Mode ($FLLn_THETA > 0$ and $FLLn_EFS_ENA = 1$), the register fields $FLLn_THETA$ and $FLLn_LAMBDA$ can be calculated as follows:

Calculate $GCD(FLL)$ using the 'Greatest Common Denominator' function:

$$GCD(FLL) = GCD(FLLn_FRATIO \times F_{REF}, F_{VCO})$$

where $GCD(x, y)$ is the greatest common denominator of x and y

Next, calculate $FLLn_THETA$ and $FLLn_LAMBDA$ using the following equations:

$$FLLn_THETA = (F_{VCO} - (FLLn_N \times FLLn_FRATIO \times F_{REF})) / GCD(FLL)$$

$$FLLn_LAMBDA = (FLLn_FRATIO \times F_{REF}) / GCD(FLL)$$

Note that, in Fractional Mode, the values of $FLLn_THETA$ and $FLLn_LAMBDA$ must be co-prime (ie. not divisible by any common integer). The calculation above ensures that the values will be co-prime.

The value of K must be a fraction less than 1 (ie. $FLLn_THETA$ must be less than $FLLn_LAMBDA$).

The FLL1 control registers are described in Table 121. The FLL2 control registers are described in Table 122. Example settings for a variety of reference frequencies and output frequencies are shown in Table 124.

REGISTER ADDRESS	BIT	LABEL	DEFAULT	DESCRIPTION
R544 (0220h) FLL1 Control (1)	0	FLL1_ENA	0	FLL1 Enable 0 = Disabled 1 = Enabled This should be set as the final step of the FLL1 enable sequence, ie. after the other FLL registers have been configured.
R545 (0221h) FLL1 Control (2)	13:8	FLL1_OUTDIV [5:0]	000000	FLL1 F_{OUT} clock divider 000000 = Reserved 000001 = Reserved 000010 = Reserved 000011 = 4 000100 = 5 000101 = 6 ... 111110 = 63 111111 = 64 ($F_{OUT} = F_{VCO} / FLL1_OUTDIV$)
	2:0	FLL1_FRATIO [2:0]	000	FLL1 F_{VCO} clock divider 000 = 1 001 = 2 010 = 4 011 = 8 1XX = 16
R546 (0222h) FLL1 Control (3)	15:0	FLL1_THETA [15:0]	0000h	FLL Fractional multiply for F_{REF} This field sets the numerator (multiply) part of the $FLL1_THETA / FLL1_LAMBDA$ ratio. Coded as $LSB = 1$.
R547 (0223h) FLL1 Control (4)	14:5	FLL1_N [9:0]	000h	FLL1 Integer multiply for F_{REF} ($LSB = 1$)

REGISTER ADDRESS	BIT	LABEL	DEFAULT	DESCRIPTION
R548 (0224h) FLL1 Control (5)	15	FLL1_BYP	0	FLL1 Bypass Select 0 = Disabled 1 = Enabled When FLL1_BYP is set, the FLL1 output is derived directly from BCLK1. In this case, FLL1 can be disabled.
	4:3	FLL1_REFCLK_DIV [1:0]	00	FLL1 Clock Reference Divider 00 = MCLK / 1 01 = MCLK / 2 10 = MCLK / 4 11 = MCLK / 8 MCLK (or other input reference) must be divided down to <=13.5MHz. For lower power operation, the reference clock can be divided down further if desired.
	1:0	FLL1_REFCLK_SRC [1:0]	00	FLL1 Clock source 00 = MCLK1 01 = MCLK2 10 = LRCLK1 11 = BCLK1
R550 (0226h) FLL1 EFS1	15:0	FLL1_LAMBDA [15:0]	0000h	FLL Fractional multiply for F _{REF} This field sets the denominator (dividing) part of the FLL1_THETA / FLL1_LAMBDA ratio. Coded as LSB = 1.
R551 (0227h) FLL1 EFS2	2:1		11	Reserved - Do not change
	0	FLL1_EFS_ENA	0	FLL Fractional Mode EFS enable 0 = Integer Mode 1 = Fractional Mode This bit should be set to 1 when FLL1_THETA > 0.

Table 121 FLL1 Register Map

REGISTER ADDRESS	BIT	LABEL	DEFAULT	DESCRIPTION
R576 (0240h) FLL2 Control (1)	0	FLL2_ENA	0	FLL2 Enable 0 = Disabled 1 = Enabled This should be set as the final step of the FLL2 enable sequence, ie. after the other FLL registers have been configured.

REGISTER ADDRESS	BIT	LABEL	DEFAULT	DESCRIPTION
R577 (0241h) FLL2 Control (2)	13:8	FLL2_OUTDIV [5:0]	000000	FLL2 F _{OUT} clock divider 000000 = Reserved 000001 = Reserved 000010 = Reserved 000011 = 4 000100 = 5 000101 = 6 ... 111110 = 63 111111 = 64 (F _{OUT} = F _{VCO} / FLL2_OUTDIV)
	2:0	FLL2_FRATIO [2:0]	000	FLL2 F _{VCO} clock divider 000 = 1 001 = 2 010 = 4 011 = 8 1XX = 16
R578 (0242h) FLL2 Control (3)	15:0	FLL2_THETA [15:0]	0000h	FLL Fractional multiply for F _{REF} This field sets the numerator (multiply) part of the FLL2_THETA / FLL2_LAMBDA ratio. Coded as LSB = 1.
R579 (0243h) FLL2 Control (4)	14:5	FLL2_N [9:0]	000h	FLL2 Integer multiply for F _{REF} (LSB = 1)
R580 (0244h) FLL2 Control (5)	15	FLL2_BYP	0	FLL2 Bypass Select 0 = Disabled 1 = Enabled When FLL2_BYP is set, the FLL2 output is derived directly from BCLK2. In this case, FLL2 can be disabled.
	4:3	FLL2_REFCLK_DIV [1:0]	00	FLL2 Clock Reference Divider 00 = MCLK / 1 01 = MCLK / 2 10 = MCLK / 4 11 = MCLK / 8 MCLK (or other input reference) must be divided down to <=13.5MHz. For lower power operation, the reference clock can be divided down further if desired.
	1:0	FLL2_REFCLK_SRC [1:0]	00	FLL2 Clock source 00 = MCLK1 01 = MCLK2 10 = LRCLK2 11 = BCLK2
R582 (0246h) FLL2 EFS1	15:0	FLL2_LAMBDA [15:0]	0000h	FLL Fractional multiply for F _{REF} This field sets the denominator (dividing) part of the FLL2_THETA / FLL2_LAMBDA ratio. Coded as LSB = 1.
R583 (0247h)	2:1		11	Reserved - Do not change

REGISTER ADDRESS	BIT	LABEL	DEFAULT	DESCRIPTION
FLL2 EFS2	0	FLL2_EFS_ENA	0	FLL Fractional Mode EFS enable 0 = Integer Mode 1 = Fractional Mode This bit should be set to 1 when FLL2_THETA > 0.

Table 122 FLL2 Register Map

FREE-RUNNING FLL CLOCK

The FLL can generate a clock signal even when no external reference is available. However, it should be noted that the accuracy of this clock is reduced, and a reference source should always be used where possible. The free-running FLL modes are not sufficiently accurate for hi-fi ADC or DAC operations, but are suitable for clocking most other functions, including the Write Sequencer, Charge Pump, DC Servo and Class D loudspeaker driver. The free-running FLL operation is ideal for clocking the accessory detection function during low-power standby operating conditions (see "External Accessory Detection").

If an accurate reference clock is initially available, then the FLL should be configured as described above. The FLL will continue to generate a stable output clock after the reference input is stopped or disconnected.

If no reference clock is available at the time of starting up the FLL, then an internal clock frequency of approximately 12MHz can be generated by implementing the following sequence:

- Enable the FLL Analogue Oscillator (FLLn_OSC_ENA = 1)
- Set the FOUT clock divider to divide by 8 (FLLn_OUTDIV = 000111)
- Configure the oscillator frequency by setting FLLn_FRC_NCO = 1 and FLLn_FRC_NCO_VAL = 19h

Note that the free-running FLL mode is not suitable for hi-fi CODEC applications. In the absence of any reference clock, the FLL output is subject to a very wide tolerance; see "Electrical Characteristics" for details of the FLL accuracy.

Note that the free-running FLL clock is selected as SYSCLK using the registers noted in Figure 68.

The free-running FLL clock may be used to support analogue functions, for which the digital audio interface is not used, and there is no applicable Sample Rate (fs). When SYSCLK is required for circuits such as the Class D, DC Servo, Control Write Sequencer or Charge Pump, then valid Sample Rate register settings are still required, even though the digital audio interface is not active.

For correct functionality when SYSCLK_SRC = 0, valid settings are required for AIF1_SR and AIF1CLK_RATE. In the case where SYSCLK_SRC = 1, then valid settings are required for AIF2_SR and AIF2CLK_RATE.

The control registers applicable to FLL free-running modes are described in Table 123.

REGISTER ADDRESS	BIT	LABEL	DEFAULT	DESCRIPTION
R544 (0220h) FLL1 Control (1)	1	FLL1_OSC_ENA	0	FLL1 Oscillator enable 0 = Disabled 1 = Enabled (Note that this field is required for free-running FLL1 modes only)
R548 (0224h) FLL1 Control (5)	12:7	FLL1_FRC_NCO_VAL [5:0]	19h	FLL1 Forced oscillator value Valid range is 000000 to 111111 0x19h (011001) = 12MHz approx (Note that this field is required for free-running FLL modes only)
	6	FLL1_FRC_NCO	0	FLL1 Forced control select 0 = Normal 1 = FLL1 oscillator controlled by FLL1_FRC_NCO_VAL (Note that this field is required for free-running FLL modes only)
R576 (0240h) FLL2 Control (1)	1	FLL2_OSC_ENA	0	FLL2 Oscillator enable 0 = Disabled 1 = Enabled (Note that this field is required for free-running FLL2 modes only)
R580 (0244h) FLL2 Control (5)	12:7	FLL2_FRC_NCO_VAL [5:0]	19h	FLL2 Forced oscillator value Valid range is 000000 to 111111 0x19h (011001) = 12MHz approx (Note that this field is required for free-running FLL modes only)
	6	FLL2_FRC_NCO	0	FLL2 Forced control select 0 = Normal 1 = FLL2 oscillator controlled by FLL2_FRC_NCO_VAL (Note that this field is required for free-running FLL modes only)

Table 123 FLL Free-Running Mode

GPIO OUTPUTS FROM FLL

For each FLL, the WM8958 has an internal signal which indicates whether the FLL Lock has been achieved. The FLL Lock status is an input to the Interrupt control circuit and can be used to trigger an Interrupt event - see "Interrupts".

The FLL Lock signal can be output directly on a GPIO pin as an external indication of FLL Lock. See "General Purpose Input/Output" for details of how to configure a GPIO pin to output the FLL Lock signal.

The FLL Clock can be output directly on a GPIO pin as a clock signal for other circuits. Note that the FLL Clock may be output even if the FLL is not selected as the WM8958 SYSCLK source. The FLL clocking configuration is illustrated in Figure 71. See "General Purpose Input/Output" for details of how to configure a GPIO pin to output the FLL Clock.

EXAMPLE FLL CALCULATION

The following example illustrates how to derive the FLL1 registers to generate 12.288 MHz output (F_{OUT}) from a 12.000 MHz reference clock (F_{REF}):

- Set FLL1_REFCLK_DIV in order to generate $F_{REF} \leq 13.5\text{MHz}$:
FLL1_REFCLK_DIV = 00 (divide by 1)
- Set FLL1_OUTDIV for the required output frequency as shown in Table 119:-
 $F_{OUT} = 12.288\text{ MHz}$, therefore FLL1_OUTDIV = 7h (divide by 8)
- Set FLL1_FRATIO for the given reference frequency as shown in Table 120:
 $F_{REF} = 12\text{MHz}$, therefore FLL1_FRATIO = 0h (divide by 1)
- Calculate F_{VCO} as given by $F_{VCO} = F_{OUT} \times FLL1_OUTDIV$:-
 $F_{VCO} = 12.288 \times 8 = 98.304\text{MHz}$
- Calculate N.K as given by $N.K = F_{VCO} / (FLL1_FRATIO \times F_{REF})$:
 $N.K = 98.304 / (1 \times 12) = 8.192$
- Set FLL1_EFS_ENA according to whether N.K is an integer.
N.K has a fractional part, therefore FLL1_EFS_ENA = 1
- Determine FLL1_N from the integer portion of N.K:-
FLL1_N = 8.
- Determine GCD(FLL), as given by $GCD(FLL) = GCD(FLL1_FRATIO \times F_{REF}, F_{VCO})$:
 $GCD(FLL) = GCD(1 \times 12000000, 98304000) = 96000$
- Determine FLL1_THETA, as given by
 $FLL1_THETA = (F_{VCO} - (FLL1_N \times FLL1_FRATIO \times F_{REF})) / GCD(FLL)$:
 $FLL1_THETA = (98304000 - (8 \times 1 \times 12000000)) / 96000$
FLL1_THETA = 24 (0018h)
- Determine FLL1_LAMBDA, as given by
 $FLL1_LAMBDA = (FLL1_FRATIO \times F_{REF}) / GCD(FLL)$:
 $FLL1_LAMBDA = (1 \times 12000000) / 96000$
FLL1_LAMBDA = 125 (007Dh)

EXAMPLE FLL SETTINGS

Table 124 provides example FLL settings for generating common SYSCLK frequencies from a variety of low and high frequency reference inputs.

F _{SOURCE}	F _{OUT} (MHz)	F _{REF} Divider	N.K	FRATIO	F _{VCCO} (MHz)	OUTDIV	FLLn_N	FLLn_ EFS_ENA	FLLn_ THETA	FLLn_ LAMBDA
32.000 kHz	12.288	1	192	16	98.304	8	0C0h	0		
32.000 kHz	11.2896	1	176.4	16	90.3168	8	0B0h	1	0002h	0005h
32.768 kHz	12.288	1	187.5	16	98.304	8	0BBh	1	0001h	0002h
32.768 kHz	11.2896	1	172.2656	16	90.3168	8	0ACh	1	0011h	0040h
44.1 kHz	11.2896	1	128	16	90.3168	8	080h	0		
48 kHz	12.288	1	128	16	98.304	8	080h	0		
128 kHz	2.048	1	96	8	98.304	48	060h	0		
128 kHz	12.288	1	96	8	98.304	8	060h	0		
512 kHz	2.048	1	96	2	98.304	48	060h	0		
512 kHz	12.288	1	96	2	98.304	8	060h	0		
1.4112 MHz	11.2896	1	64	1	90.3168	8	040h	0		
2.8224 MHz	11.2896	1	32	1	90.3168	8	020h	0		
1.536 MHz	12.288	1	64	1	98.304	8	040h	0		
3.072 MHz	12.288	1	32	1	98.304	8	020h	0		
11.2896	12.288	1	8.7075	1	98.304	8	008h	1	0068h	0093h
12.000 MHz	12.288	1	8.192	1	98.304	8	008h	1	0018h	007Dh
12.000 MHz	11.2896	1	7.5264	1	90.3168	8	007h	1	0149h	0271h
12.288 MHz	12.288	1	8	1	98.304	8	008h	0		
12.288 MHz	11.2896	1	7.35	1	90.3168	8	007h	1	0007h	0014h
13.000 MHz	12.288	1	7.5618	1	98.304	8	007h	1	0391h	0659h
13.000 MHz	11.2896	1	6.9474	1	90.3168	8	006h	1	1E12h	1FBDh
19.200 MHz	12.288	2	10.24	1	98.304	8	00Ah	1	0006h	0019h
19.200 MHz	11.2896	2	9.408	1	90.3168	8	009h	1	0033h	007Dh
24 MHz	12.288	2	8.192	1	98.304	8	008h	1	0018h	007Dh
24 MHz	11.2896	2	7.5264	1	90.3168	8	007h	1	0149h	0271h
26 MHz	12.288	2	7.5618	1	98.304	8	007h	1	0391h	0659h
26 MHz	11.2896	2	6.9474	1	90.3168	8	006h	1	1E12h	1FBDh
27 MHz	12.288	2	7.2818	1	98.304	8	007h	1	013Dh	0465h
27 MHz	11.2896	2	6.6901	1	90.3168	8	006h	1	050Eh	0753h

$F_{OUT} = (F_{SOURCE} / F_{REF} \text{ Divider}) * N.K * FRATIO / OUTDIV$
 The values of N and K are contained in the FLLn_N, FLLn_THETA and FLLn_LAMBDA registers as shown above.
 See Table 121 and Table 122 for the coding of the FLLn_REFCLK_DIV, FLLn_FRATIO and FLLn_OUTDIV registers.

Table 124 Example FLL Settings

SAMPLE RATE CONVERSION

The WM8958 supports two main digital audio interfaces, AIF1 and AIF2. These interfaces are configured independently and may operate entirely asynchronously to each other. The WM8958 performs stereo full-duplex sample rate conversion between the audio interfaces, allowing digital audio to be routed between the interfaces, and allowing asynchronous audio data to be mixed together.

The Sample Rate Converters (SRCs) are configured automatically within the WM8958, and no user settings are required. The SRCs are enabled automatically when required and are disabled at other times. Synchronisation between the audio interfaces is not instantaneous when the clocking or sample rate configurations are updated; the lock status of the SRCs is signalled via the GPIO or Interrupt circuits, as described in “General Purpose Input/Output” and “Interrupts”.

Separate clocks can be used for AIF1 and AIF2, allowing asynchronous operation on these interfaces. The digital mixing core is clocked by SYSCLK, which is linked to either AIF1CLK or AIF2CLK, as described in “Clocking and Sample Rates”. The digital mixing core is, therefore, always synchronised to AIF1, or to AIF2, or to both interfaces at once.

SAMPLE RATE CONVERTER 1 (SRC1)

SRC1 performs sample rate conversion of digital audio data input to the WM8958. Sample Rate Conversion is required when digital audio data is received on an audio interface that is not synchronised to the digital mixing core.

SRC1 is automatically configured on AIF1 or AIF2, depending on the selected Clocking and Sample Rate configuration. Note that SRC1 cannot convert input data on AIF1 and AIF2 simultaneously. Sample Rate conversion on AIF1 is only supported on TDM Timeslot 0.

The SRC1 Lock status indicates when audio data can be received on the interface channel that is not synchronised to the digital mixing core. No audio will be present on this signal path until SRC1 Lock is achieved.

SAMPLE RATE CONVERTER 2 (SRC2)

SRC2 performs sample rate conversion of digital audio data output from the WM8958. Sample Rate Conversion is required when digital audio data is transmitted on an audio interface that is not synchronised to the digital mixing core.

SRC2 is automatically configured on AIF1 or AIF2, depending on the selected Clocking and Sample Rate configuration. Note that SRC2 cannot convert output data on AIF1 and AIF2 simultaneously. Sample Rate conversion on AIF1 is only supported on TDM Timeslot 0.

The SRC2 Lock status indicates when audio data can be transmitted on the interface channel that is not synchronised to the digital mixing core. No audio will be present on this signal path until SRC2 Lock is achieved.

SAMPLE RATE CONVERTER RESTRICTIONS

The following restrictions apply to the configuration of the WM8958 Sample Rate Converters.

No SRC on AIF1 Timeslot 1. Sample Rate Conversion on audio interface AIF1 is not supported on the TDM Timeslot 1. Therefore, it is not possible to route digital audio between AIF1 Timeslot 1 and AIF2, or to mix together audio from these interface paths. Note that this only applies when the SRC is applied to AIF1.

Maximum of three sample rates in the system. The audio sample rate of AIF1 input and AIF1 output may be different to each other. The audio sample rate of AIF2 input and AIF2 output may be different to each other. However, it is not possible to have four different sample rates operating simultaneously, as this would require sample rate conversion in too many paths. A maximum of three different sample rates can be supported in the system.

No SRC capability when using 88.2kHz or 96kHz AIF input (DAC playback). If either interface is configured for 88.2kHz or 96kHz sample rate, then the digital mixing core must also be configured for this sample rate. Sample Rate Conversion cannot be supported in this mode, therefore AIF output is not supported at any sample rate under these conditions.

Restricted Sample Rate options when AIF1 and AIF2 are synchronised. When the same clock source is used for AIF1CLK and AIF2CLK, and mixed sample rates are selected on both interfaces, then the DAC sample rate of one interface must be the same as the ADC sample rate of the other.

- If AIF1CLK_SRC = AIF2CLK_SRC
- And AIF1DAC_DIV ≠ AIF1ADC_DIV
- And AIF2DAC_DIV ≠ AIF2ADC_DIV
- Then the DAC sample rate of one interface must be the same as the ADC sample rate of the other.

Restricted Sample Rate options when AIF1 and AIF2 are not synchronised. When a different clock source is used for AIF1CLK and AIF2CLK, then the AIF to which the SYSCLK is synchronised cannot be mixed sample rates.

- If AIF1CLK_SRC ≠ AIF2CLK_SRC
- And SYSCLK_SRC = 0
- Then AIF1DAC_DIV and AIF1ADC_DIV must be set to 000

- If AIF1CLK_SRC ≠ AIF2CLK_SRC
- And SYSCLK_SRC = 1
- Then AIF2DAC_DIV and AIF2ADC_DIV must be set to 000

SAMPLE RATE CONVERTER CONFIGURATION ERROR INDICATION

The WM8958 verifies the register settings relating to Clocking, Sample Rates and Sample Rate Conversion. If an invalid configuration is attempted, then the SR_ERROR register will indicate the error by showing a non-zero value. This read-only field may be checked to confirm that the WM8958 can support the selected Clocking and Sample Rate settings.

REGISTER ADDRESS	BIT	LABEL	DEFAULT	DESCRIPTION
R530 (0212h) Rate Status	3:0	SR_ERROR [3:0]	0000	<p>Sample Rate Configuration status</p> <p>Indicates an error with the register settings related to sample rate configuration</p> <p>0000 = No errors</p> <p>0001 = Invalid sample rate</p> <p>0010 = Invalid AIF divide</p> <p>0011 = ADC and DAC divides both set in an interface</p> <p>0100 = Invalid combination of AIF divides and sample-rate</p> <p>0101 = Invalid set of enables for 96kHz mode</p> <p>0110 = Invalid SYSCLK rate (derived from AIF1CLK_RATE or AIF2CLK_RATE)</p> <p>0111 = Mixed ADC and DAC rates in SYSCLK AIF when AIFs are asynchronous</p> <p>1000 = Invalid combination of sample rates when both AIFs are from the same clock source</p> <p>1001 = Invalid combination of mixed ADC/DAC AIFs when both from the same clock source</p> <p>1010 = AIF1DAC2 (Timeslot 1) ports enabled when SRCs connected to AIF1</p>

Table 125 Sample Rate Converter Configuration Status

CONTROL INTERFACE

The WM8958 is controlled by writing to registers through a 2-wire serial control interface. Readback is available for all registers, including Chip ID and power management status.

Note that the Control Interface function can be supported with or without system clocking. Where possible, the register map access is synchronised with SYSCLK in order to ensure predictable operation of cross-domain functions. See "Clocking and Sample Rates" for further details of Control Interface clocking.

The WM8958 is a slave device on the control interface; SCLK is a clock input, while SDAT is a bi-directional data pin. To allow arbitration of multiple slaves (and/or multiple masters) on the same interface, the WM8958 transmits logic 1 by tri-stating the SDAT pin, rather than pulling it high. An external pull-up resistor is required to pull the SDAT line high so that the logic 1 can be recognised by the master.

In order to allow many devices to share a single 2-wire control bus, every device on the bus has a unique 8-bit device ID (this is not the same as the address of each register in the WM8958). The device ID is selectable on the WM8958, using the ADDR pin as shown in Table 126. The LSB of the Device ID is the Read/Write bit; this bit is set to logic 1 for "Read" and logic 0 for "Write".

An internal pull-down resistor is enabled by default on the ADDR pin; this can be configured using the ADDR_PD register bit described in Table 128.

ADDR	DEVICE ID
Low	0011 0100 (34h)
High	0011 0110 (36h)

Table 126 Control Interface Device ID Selection

The WM8958 operates as a slave device only. The controller indicates the start of data transfer with a high to low transition on SDAT while SCLK remains high. This indicates that a device ID, register address and data will follow. The WM8958 responds to the start condition and shifts in the next eight bits on SDAT (8-bit device ID, including Read/Write bit, MSB first). If the device ID received matches the device ID of the WM8958, then the WM8958 responds by pulling SDAT low on the next clock pulse (ACK). If the device ID is not recognised or the R/W bit is set incorrectly, the WM8958 returns to the idle condition and waits for a new start condition and valid address.

If the device ID matches the device ID of the WM8958, the data transfer continues as described below. The controller indicates the end of data transfer with a low to high transition on SDAT while SCLK remains high. After receiving a complete address and data sequence the WM8958 returns to the idle state and waits for another start condition. If a start or stop condition is detected out of sequence at any point during data transfer (i.e. SDAT changes while SCLK is high), the device returns to the idle condition.

The WM8958 supports the following read and write operations:

- Single write
- Single read
- Multiple write using auto-increment
- Multiple read using auto-increment

The sequence of signals associated with a single register write operation is illustrated in Figure 73.

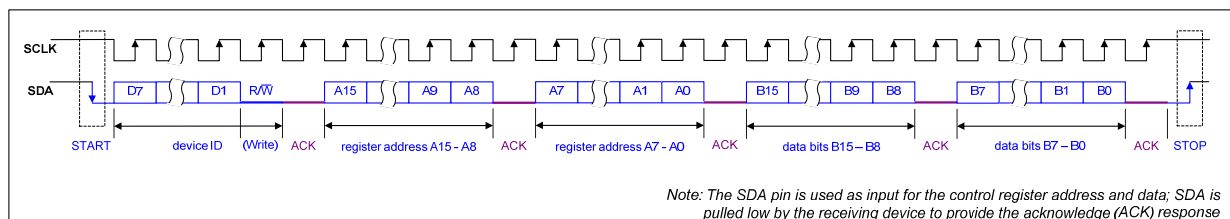

Figure 73 Control Interface 2-wire (I2C) Register Write

The sequence of signals associated with a single register read operation is illustrated in Figure 74.

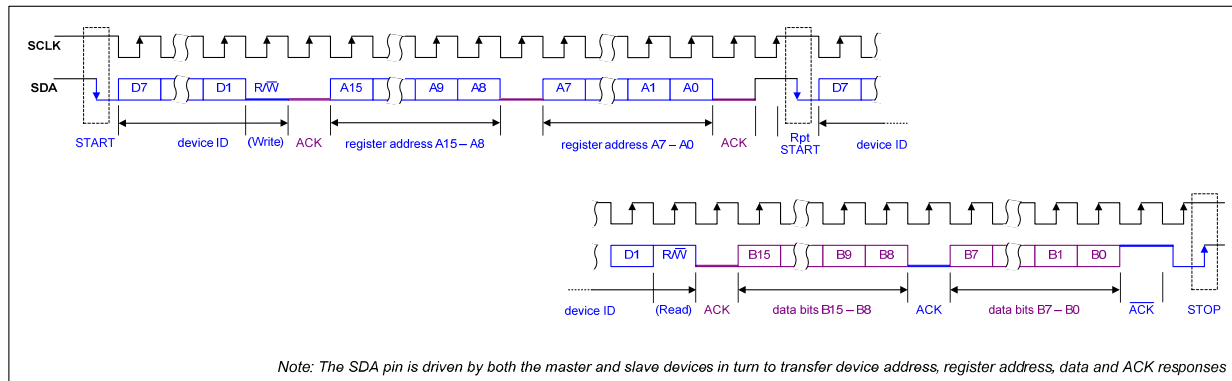

Figure 74 Control Interface 2-wire (I2C) Register Read

The Control Interface also supports other register operations, as listed above. The interface protocol for these operations is summarised below. The terminology used in the following figures is detailed in Table 127.

Note that, for multiple write and multiple read operations, the auto-increment option must be enabled. This feature is enabled by default, as noted in Table 128.

TERMINOLOGY		DESCRIPTION
S		Start Condition
Sr		Repeated start
A		Acknowledge (SDA Low)
\bar{A}		Not Acknowledge (SDA High)
P		Stop Condition
R/W	ReadNotWrite	0 = Write 1 = Read
[White field]		Data flow from bus master to WM8958
[Grey field]		Data flow from WM8958 to bus master

Table 127 Control Interface Terminology

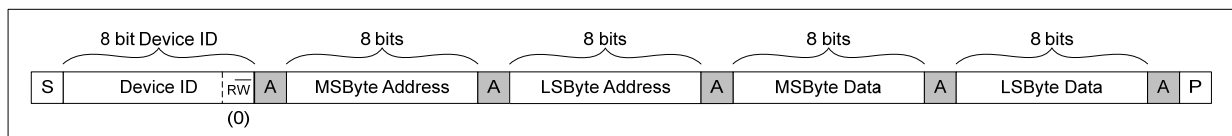

Figure 75 Single Register Write to Specified Address

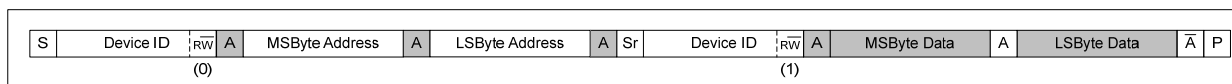

Figure 76 Single Register Read from Specified Address

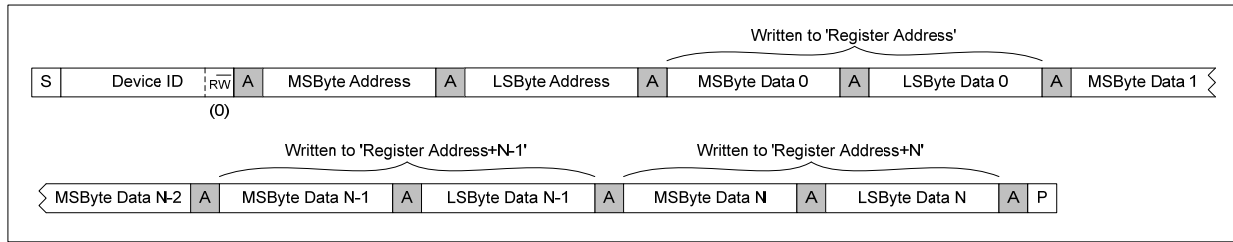

Figure 77 Multiple Register Write to Specified Address using Auto-increment

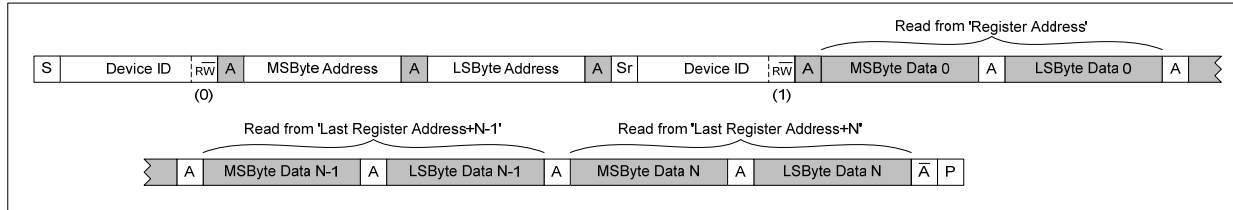

Figure 78 Multiple Register Read from Specified Address using Auto-increment

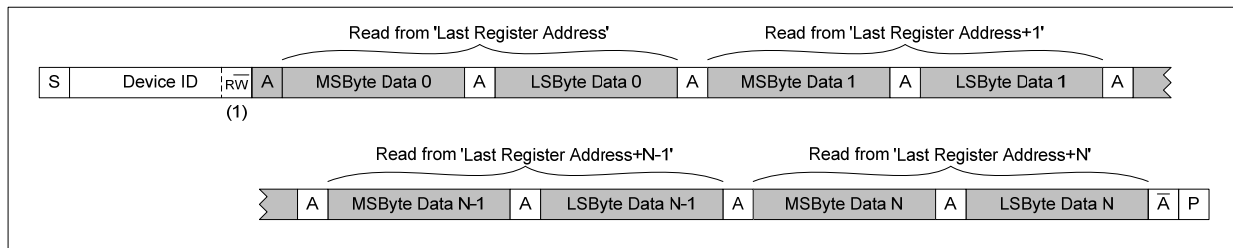

Figure 79 Multiple Register Read from Last Address using Auto-increment

Multiple Write and Multiple Read operations enable the host processor to access sequential blocks of the data in the WM8958 register map faster than is possible with single register operations. The auto-increment option is enabled when the AUTO_INC register bit is set. This bit is defined in Table 128. Auto-increment is enabled by default.

REGISTER ADDRESS	BIT	LABEL	DEFAULT	DESCRIPTION
R257 (0101h) Control Interface	2	AUTO_INC	1	Enables address auto-increment 0 = Disabled 1 = Enabled
R1825 (0721h) Pull Control (2)	8	ADDR_PD	1	ADDR Pull-down enable 0 = Disabled 1 = Enabled

Table 128 Control Interface Configuration

CONTROL WRITE SEQUENCER

The Control Write Sequencer is a programmable unit that forms part of the WM8958 control interface logic. It provides the ability to perform a sequence of register write operations with the minimum of demands on the host processor - the sequence may be initiated by a single operation from the host processor and then left to execute independently.

Default sequences for Start-Up of each output driver and Shut-Down are provided (see “Default Sequences” section). It is recommended that these default sequences are used unless changes become necessary.

When a sequence is initiated, the sequencer performs a series of pre-defined register writes. The host processor informs the sequencer of the start index of the required sequence within the sequencer’s memory. At each step of the sequence, the contents of the selected register fields are read from the sequencer’s memory and copied into the WM8958 control registers. This continues sequentially through the sequencer’s memory until an “End of Sequence” bit is encountered; at this point, the sequencer stops and an Interrupt status flag is asserted. For cases where the timing of the write sequence is important, a programmable delay can be set for specific steps within the sequence.

Note that the Control Write Sequencer’s internal clock is derived from the internal clock SYS_CLK which must be enabled as described in “Clocking and Sample Rates”. The clock division from SYS_CLK is handled transparently by the WM8958 without user intervention, provided that SYS_CLK is configured as specified in “Clocking and Sample Rates”.

INITIATING A SEQUENCE

The Register fields associated with running the Control Write Sequencer are described in Table 129. Note that the operation of the Control Write Sequencer also requires the internal clock SYS_CLK to be configured as described in “Clocking and Sample Rates”.

The Write Sequencer is enabled by setting the WSEQ_ENA bit. The start index of the required sequence must be written to the WSEQ_START_INDEX field.

The Write Sequencer stores up to 128 register write commands. These are defined in Registers R12288 to R12799. There are 4 registers used to define each of the 128 possible commands. The value of WSEQ_START_INDEX selects the registers applicable to the first write command in the selected sequence.

Setting the WSEQ_START bit initiates the sequencer at the given start index. The Write Sequencer can be interrupted by writing a logic 1 to the WSEQ_ABORT bit.

The current status of the Write Sequencer can be read using two further register fields - when the WSEQ_BUSY bit is asserted, this indicates that the Write Sequencer is busy. Note that, whilst the Control Write Sequencer is running a sequence (indicated by the WSEQ_BUSY bit), normal read/write operations to the Control Registers cannot be supported. The index of the current step in the Write Sequencer can be read from the WSEQ_CURRENT_INDEX field; this is an indicator of the sequencer’s progress. On completion of a sequence, this field holds the index of the last step within the last commanded sequence.

When the Write Sequencer reaches the end of a sequence, it asserts the WSEQ_DONE_EINT flag in Register R1841 (see Table 90). This flag can be used to generate an Interrupt Event on completion of the sequence. Note that the WSEQ_DONE_EINT flag is asserted to indicate that the WSEQ is NOT Busy.

REGISTER ADDRESS	BIT	LABEL	DEFAULT	DESCRIPTION
R272 (0110h) Write Sequencer Ctrl (1)	15	WSEQ_ENA	0	Write Sequencer Enable. 0 = Disabled 1 = Enabled
	9	WSEQ_ABORT	0	Writing a 1 to this bit aborts the current sequence and returns control of the device back to the serial control interface.
	8	WSEQ_START	0	Writing a 1 to this bit starts the write sequencer at the index location selected by WSEQ_START_INDEX. The sequence continues until it reaches an "End of sequence" flag. At the end of the sequence, this bit will be reset by the Write Sequencer.
	6:0	WSEQ_START_INDEX [6:0]	000_0000	Sequence Start Index. This field determines the memory location of the first command in the selected sequence. There are 127 Write Sequencer RAM addresses: 00h = WSEQ_ADDR0 (R12288) 01h = WSEQ_ADDR1 (R12292) 02h = WSEQ_ADDR2 (R12296) 7Fh = WSEQ_ADDR127 (R12796)
R273 (0111h) Write Sequencer Ctrl (2)	8	WSEQ_BUSY (read only)	0	Sequencer Busy flag (Read Only). 0 = Sequencer idle 1 = Sequencer busy Note: it is not possible to write to control registers via the control interface while the Sequencer is Busy.
	6:0	WSEQ_CURRENT_INDEX [6:0] (read only)	000_0000	Sequence Current Index. This indicates the memory location of the most recently accessed command in the write sequencer memory. Coding is the same as WSEQ_START_INDEX.

Table 129 Write Sequencer Control - Initiating a Sequence

PROGRAMMING A SEQUENCE

A sequence consists of write operations to data bits (or groups of bits) within the control registers. Each write operation is defined by a block of 4 registers, which contain 6 fields as described in this section.

The block of 4 registers is the same for up to 128 steps held in the sequencer memory. Multiple sequences can be held in the memory at the same time; each sequence occupies its own range within the 128 available register blocks.

The following 6 fields are replicated 128 times - one for each of the sequencer's 128 steps. In the following descriptions, the term 'n' is used to denote the step number, from 0 to 127.

WSEQ_ADDR_n is a 14-bit field containing the Control Register Address in which the data should be written.

WSEQ_DATA_n is an 8-bit field which contains the data to be written to the selected Control Register. The WSEQ_DATA_WIDTH_n field determines how many of these bits are written to the selected register; the most significant bits (above the number indicated by WSEQ_DATA_WIDTH_n) are ignored.

WSEQ_DATA_START n is a 4-bit field which identifies the LSB position within the selected Control Register to which the data should be written. For example, setting WSEQ_DATA_START n = 0100 will select bit 4 as the LSB position; in this case, 4-bit data would be written to bits 7:4.

WSEQ_DATA_WIDTH n is a 3-bit field which identifies the width of the data block to be written. This enables selected portions of a Control Register to be updated without any concern for other bits within the same register, eliminating the need for read-modify-write procedures. Values of 0 to 7 correspond to data widths of 1 to 8 respectively. For example, setting WSEQ_DATA_WIDTH n = 010 will cause a 3-bit data block to be written. Note that the maximum value of this field corresponds to an 8-bit data block; writing to register fields greater than 8 bits wide must be performed using two separate operations of the Control Write Sequencer.

WSEQ_DELAY n is a 4-bit field which controls the waiting time between the current step and the next step in the sequence i.e. the delay occurs after the write in which it was called. The total delay time per step (including execution) is defined below, giving a useful range of execution/delay times from 562 μ s up to 2.048s per step:

$$T = k \times (2^{\text{WSEQ_DELAY}} + 8)$$

where $k = 62.5\mu\text{s}$ (under recommended operating conditions)

WSEQ_EOS n is a 1-bit field which indicates the End of Sequence. If this bit is set, then the Control Write Sequencer will automatically stop after this step has been executed.

The register definitions for Step 0 are described in Table 130. The equivalent definitions also apply to Step 1 through to Step 127, in the subsequent register address locations.

REGISTER ADDRESS	BIT	LABEL	DEFAULT	DESCRIPTION
R12288 (3000h) Write Sequencer 0	13:0	WSEQ_ADDR 0 [13:0]	0000h	Control Register Address to be written to in this sequence step.
R12289 (3001h) Write Sequencer 1	7:0	WSEQ_DATA 0 [7:0]	00h	Data to be written in this sequence step. When the data width is less than 8 bits, then one or more of the MSBs of WSEQ_DATA n are ignored. It is recommended that unused bits be set to 0.
R12290 (3002h) Write Sequencer 2	10:8	WSEQ_DATA _WIDTH0 [2:0]	000	Width of the data block written in this sequence step. 000 = 1 bit 001 = 2 bits 010 = 3 bits 011 = 4 bits 100 = 5 bits 101 = 6 bits 110 = 7 bits 111 = 8 bits
	3:0	WSEQ_DATA _START0 [3:0]	0000	Bit position of the LSB of the data block written in this sequence step. 0000 = Bit 0 ... 1111 = Bit 15
R12291 (3003h) Write Sequencer 3	8	WSEQ_EOS0	0	End of Sequence flag. This bit indicates whether the Control Write Sequencer should stop after executing this step. 0 = Not end of sequence 1 = End of sequence (Stop the sequencer after this step).
	3:0	WSEQ_DELA Y0 [3:0]	0000	Time delay after executing this step. Total time per step (including execution) = $62.5\mu\text{s} \times (2^{\text{WSEQ_DELAY}} + 8)$

Table 130 Write Sequencer Control - Programming a Sequence

Note that a 'Dummy' write can be inserted into a control sequence by commanding the sequencer to write a value of 0 to bit 0 of Register R255 (00FFh). This is effectively a write to a non-existent register location. This can be used in order to create placeholders ready for easy adaptation of a control sequence. For example, a sequence could be defined to power-up a mono signal path from DACL to headphone, with a 'dummy' write included to leave space for easy modification to a stereo signal path configuration. Dummy writes can also be used in order to implement additional time delays between register writes. Dummy writes are included in both of the Headphone start-up sequences - see Table 131 and Table 132.

In summary, the Control Register to be written is set by the WSEQ_ADDR n field. The data bits that are written are determined by a combination of WSEQ_DATA_START n , WSEQ_DATA_WIDTH n and WSEQ_DATA n . This is illustrated below for an example case of writing to the VMID_SEL field within Register R1 (0001h).

In this example, the Start Position is bit 01 (WSEQ_DATA_START n = 0001b) and the Data width is 2 bits (WSEQ_DATA_WIDTH n = 0001b). With these settings, the Control Write Sequencer would update the Control Register R1 [2:1] with the contents of WSEQ_DATA n [1:0].

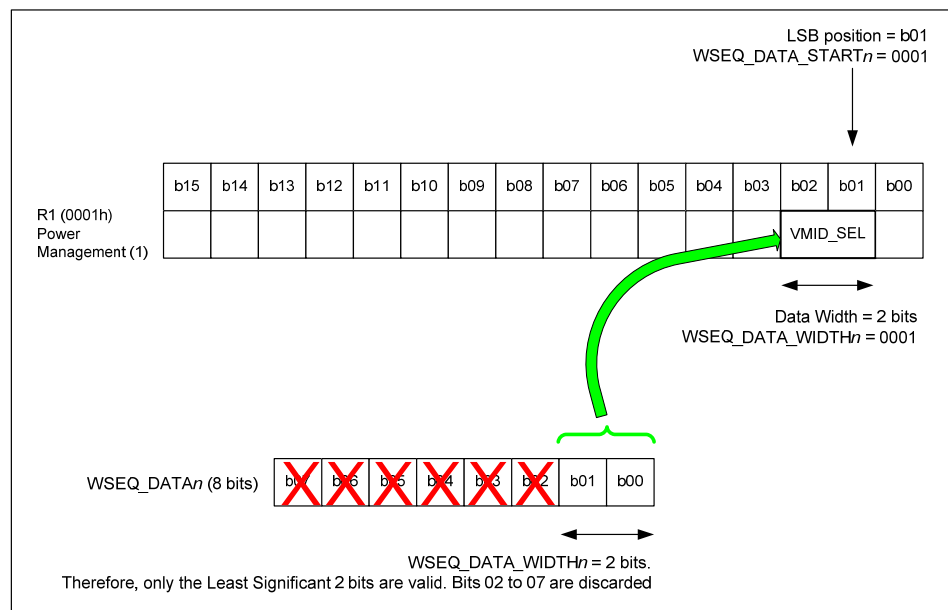

Figure 80 Control Write Sequencer Example

DEFAULT SEQUENCES

When the WM8958 is powered up, a number of Control Write Sequences are available through default settings in the sequencer memory locations. The pre-programmed default settings include Start-Up and Shut-Down sequences for each of the output drivers. Note that the default sequences do not include audio signal path or gain setting configuration; this must be implemented prior to scheduling any of the default Start-Up sequences.

The entire sequencer memory may be programmed to users' own settings at any time, as described in "Programming a Sequence". Users' own settings remain in memory regardless of WSEQ_ENA, and are not affected by software resets (i.e. writing to Register R0). However, any non-default sequences are lost when the device is powered down.

The following default control sequences are provided:

1. Headphone Cold Start-Up - This sequence powers up the headphone driver and charge pump. It commands the DC Servo to perform offset correction. It enables the master bias required for analogue functions. This sequence is intended for enabling the headphone output after initial power-on, when DC offset correction has not previously been run.

2. Headphone Warm Start-Up - This sequence is similar to the Headphone Cold Start-Up, but does not include the DC Servo operation. This sequence is intended for fast enabling of the headphone output when DC offset correction has previously been scheduled and provided the analogue gain settings have not been updated since scheduling the DC offset correction.
3. Speaker Start-Up - This sequence powers up the stereo speaker driver. It also enables the master bias required for analogue functions.
4. Earpiece Start-Up - This sequence powers up the earpiece driver. It also enables the master bias required for analogue functions. The soft-start VMID option is used in order to suppress pops when the driver is enabled. This sequence is intended for enabling the earpiece driver when the master bias has not previously been enabled.
5. Line Output Start-Up - This sequence powers up the line outputs. Active discharge of the line outputs is selected, followed by the soft-start VMID enable, followed by selection of the master bias and un-muting of the line outputs. This sequence is intended for enabling the line drivers when the master bias has not previously been enabled.
6. Speaker and Headphone Fast Shut-Down - This sequence implements a fast shutdown of the speaker and headphone drivers. It also disables the DC Servo and charge pump circuits, and disables the analogue bias circuits using the soft-start (ramp) feature. This sequence is intended as a shut-down sequence when only the speaker or headphone drivers are enabled.
7. Generic Shut-Down - This sequence shuts down all of the WM8958 output drivers, DC Servo, charge pump and analogue bias circuits. It is similar to the Fast Shut-Down sequence, with the additional control of the earpiece and line output drivers. Active discharge of the line outputs is included and all drivers are disabled as part of this sequence.

Specific details of each of these sequences is provided below.

Headphone Cold Start-Up

The Headphone Cold Start-Up sequence is initiated by writing 8100h to Register 272 (0110h). This single operation starts the Control Write Sequencer at Index Address 0 (00h) and executes the sequence defined in Table 131.

This sequence takes approximately 296ms to run.

WSEQ INDEX	REGISTER ADDRESS	WIDTH	START	DATA	DELAY	EOS	DESCRIPTION
0 (00h)	R57 (0039h)	5 bits	Bit 2	1Bh	0h	0b	STARTUP_BIAS_ENA = 1 VMID_BUF_ENA = 1 VMID_RAMP[1:0] = 11b (delay = 0.5625ms)
1 (01h)	R1 (0001h)	3 bits	Bit 0	03h	9h	0b	BIAS_ENA = 1 VMID_SEL[1:0] = 01b (delay = 32.5ms)
2 (02h)	R76 (004Ch)	1 bit	Bit 15	01h	6h	0b	CP_ENA = 1 (delay = 4.5ms)
3 (03h)	R1 (0001h)	2 bits	Bit 8	03h	0h	0b	HPOUT1R_ENA = 1 HPOUT1L_ENA = 1 (delay = 0.5625ms)
4 (04h)	R96 (0060h)	5 bits	Bit 1	11h	0h	0b	HPOUT1R_DLY = 1 HPOUT1L_DLY = 1 (delay = 0.5625ms)
5 (05h)	R84 (0054h)	6 bits	Bit 0	33h	Ch	0b	DCS_ENA_CHAN_0 = 1 DCS_ENA_CHAN_1 = 1 DCS_TRIG_STARTUP_0 = 1 DCS_TRIG_STARTUP_1 = 1 (delay = 256.5ms)

WSEQ INDEX	REGISTER ADDRESS	WIDTH	START	DATA	DELAY	EOS	DESCRIPTION
6 (06h)	R255 (00FFh)	1 bit	Bit 0	00h	0h	0b	Dummy Write for expansion (delay = 0.5625ms)
7 (07h)	R96 (0060h)	6 bits	Bit 2	3Bh	0h	1b	HPOUT1R_OUTP = 1 HPOUT1R_RMV_SHORT = 1 HPOUT1_DLY = 1 HPOUT1L_OUTP = 1 HPOUT1L_RMV_SHORT = 1 (delay = 0.5625ms)

Table 131 Headphone Cold Start-Up Default Sequence

Headphone Warm Start-Up

The Headphone Warm Start-Up sequence can be initiated by writing 8108h to Register 272 (0110h). This single operation starts the Control Write Sequencer at Index Address 8 (08h) and executes the sequence defined in Table 132.

This sequence takes approximately 40ms to run.

WSEQ INDEX	REGISTER ADDRESS	WIDTH	START	DATA	DELAY	EOS	DESCRIPTION
8 (08h)	R57 (0039h)	5 bits	Bit 2	1Bh	0h	0b	STARTUP_BIAS_ENA = 1 VMID_BUF_ENA = 1 VMID_RAMP[1:0] = 11b (delay = 0.5625ms)
9 (09h)	R1 (0001h)	3 bits	Bit 0	03h	9h	0b	BIAS_ENA = 1 VMID_SEL[1:0] = 01b (delay = 32.5ms)
10 (0Ah)	R76 (004Ch)	1 bits	Bit 15	01h	6h	0b	CP_ENA = 1 (delay = 4.5ms)
11 (0Bh)	R1 (0001h)	2 bits	Bit 8	03h	0h	0b	HPOUT1R_ENA = 1 HPOUT1L_ENA = 1 (delay = 0.5625ms)
12 (0Ch)	R96 (0060h)	5 bits	Bit 1	11h	0h	0b	HPOUT1R_DLY = 1 HPOUT1L_DLY = 1 (delay = 0.5625ms)
13 (0Dh)	R84 (0054h)	2 bits	Bit 0	03h	0h	0b	DCS_ENA_CHAN_0 = 1 DCS_ENA_CHAN_1 = 1 (delay = 0.5625ms)
14 (0Eh)	R255 (00FFh)	1 bits	Bit 0	00h	0h	0b	Dummy Write for expansion (delay = 0.5625ms)
15 (0Fh)	R96 (0060h)	6 bits	Bit 2	3Bh	0h	1b	HPOUT1R_OUTP = 1 HPOUT1R_RMV_SHORT = 1 HPOUT1_DLY = 1 HPOUT1L_OUTP = 1 HPOUT1L_RMV_SHORT = 1 (delay = 0.5625ms)

Table 132 Headphone Warm Start-Up Default Sequence

Speaker Start-Up

The Speaker Start-Up sequence can be initiated by writing 8110h to Register 272 (0110h). This single operation starts the Control Write Sequencer at Index Address 16 (10h) and executes the sequence defined in Table 133.

This sequence takes approximately 34ms to run.

WSEQ INDEX	REGISTER ADDRESS	WIDTH	START	DATA	DELAY	EOS	DESCRIPTION
16 (10h)	R57 (39h)	5 bits	Bit 2	1Bh	0h	0b	STARTUP_BIAS_ENA = 1 VMID_BUF_ENA = 1 VMID_RAMP[1:0] = 11b (delay = 0.5625ms)
17 (11h)	R1 (01h)	3 bits	Bit 0	03h	9h	0b	BIAS_ENA = 1 VMID_SEL[1:0] = 01b (delay = 32.5ms)
18 (12h)	R1 (01h)	2 bits	Bit 12	03h	0h	1b	SPKOUTL_ENA = 1 SPKOUTR_ENA = 1 (delay = 0.5625ms)

Table 133 Speaker Start-Up Default Sequence

Earpiece Start-Up

The Earpiece Start-Up sequence can be initiated by writing 8113h to Register 272 (0110h). This single operation starts the Control Write Sequencer at Index Address 19 (13h) and executes the sequence defined in Table 134.

This sequence takes approximately 259ms to run.

WSEQ INDEX	REGISTER ADDRESS	WIDTH	START	DATA	DELAY	EOS	DESCRIPTION
19 (13h)	R57 (39h)	6 bits	Bit 1	27h	0h	0b	BIAS_SRC = 1 STARTUP_BIAS_ENA = 1 VMID_BUF_ENA = 1 VMID_RAMP[1:0] = 10b (delay = 0.5625ms)
20 (14h)	R56 (38h)	1 bit	Bit 6	01h	0h	0b	HPOUT2_IN_ENA = 1 (delay = 0.5625ms)
21 (15h)	R31 (1Fh)	1 bit	Bit 5	00h	0h	1b	HPOUT2_MUTE = 0 (delay = 0.5625ms)
22 (16h)	R1 (01h)	1 bit	Bit 11	01h	0h	0b	HPOUT2_ENA = 1 (delay = 0.5625ms)
23 (17h)	R1 (01h)	3 bits	Bit 0	03h	Ch	0b	BIAS_ENA = 1 VMID_SEL[1:0] = 01b (delay = 256.5ms)
24 (18h)	R57 (39h)	1 bit	Bit 1	00h	0h	0b	BIAS_SRC = 0 (delay = 0.5625ms)

Table 134 Earpiece Start-Up Default Sequence

Line Output Start-Up

The Line Output Start-Up sequence can be initiated by writing 8119h to Register 272 (0110h). This single operation starts the Control Write Sequencer at Index Address 25 (19h) and executes the sequence defined in Table 135.

This sequence takes approximately 517ms to run.

WSEQ INDEX	REGISTER ADDRESS	WIDTH	START	DATA	DELAY	EOS	DESCRIPTION
25 (19h)	R56 (38h)	2 bits	Bit 4	03h	0h	0b	LINEOUT2_DISCH = 1 LINEOUT1_DISCH = 1 (delay = 0.5625ms)
26 (1Ah)	R57 (39h)	6 bits	Bit 1	27h	0h	0b	BIAS_SRC = 1 STARTUP_BIAS_ENA = 1 VMID_BUF_ENA = 1 VMID_RAMP[1:0] = 10b (delay = 0.5625ms)
27 (1Bh)	R56 (38h)	1 bit	Bit 7	01h	0h	0b	LINEOUT_VMID_BUF_ENA = 1 (delay = 0.5625ms)
28 (1Ch)	R3 (03h)	4 bits	Bit 10	0Fh	0h	0b	LINEOUT2P_ENA = 1 LINEOUT2N_ENA = 1 LINEOUT1P_ENA = 1 LINEOUT1N_ENA = 1 (delay = 0.5625ms)
29 (1Dh)	R56 (38h)	2 bits	Bit 4	00h	0h	0b	LINEOUT2_DISCH = 0 LINEOUT1_DISCH = 0 (delay = 0.5625ms)
30 (1Eh)	R1 (01h)	3 bits	Bit 0	03h	Dh	0b	BIAS_ENA = 1 VMID_SEL = 01b (delay = 512.5ms)
31 (1Fh)	R57 (39h)	1 bit	Bit 1	00h	0h	0b	BIAS_SRC = 0 (delay = 0.5625ms)
32 (20h)	R30 (1Eh)	2 bits	Bit 5	00h	0h	0b	LINEOUT1P_MUTE = 0 LINEOUT1N_MUTE = 0 (delay = 0.5625ms)
33 (21h)	R30 (1Eh)	2 bits	Bit 1	00h	0h	1b	LINEOUT2P_MUTE = 0 LINEOUT2N_MUTE = 0 (delay = 0.5625ms)

Table 135 Line Output Start-Up Default Sequence

Speaker and Headphone Fast Shut-Down

The Speaker and Headphone Fast Shut-Down sequence can be initiated by writing 8122h to Register 272 (0110h). This single operation starts the Control Write Sequencer at Index Address 34 (22h) and executes the sequence defined in Table 136.

This sequence takes approximately 37ms to run.

WSEQ INDEX	REGISTER ADDRESS	WIDTH	START	DATA	DELAY	EOS	DESCRIPTION
34 (22h)	R96 (60h)	7 bits	Bit 1	00h	0h	0b	HPOUT1R_DLY = 0 HPOUT1R_OUTP = 0 HPOUT1R_RMV_SHORT = 0 HPOUT1L_DLY = 0 HPOUT1L_OUTP = 0 HPOUT1L_RMV_SHORT = 0 (delay = 0.5625ms)
35 (23h)	R84 (54h)	2 bits	Bit 0	00h	0h	0b	DCS_ENA_CHAN_0 = 0 DCS_ENA_CHAN_1 = 0 (delay = 0.5625ms)
36 (24h)	R1 (01h)	2 bits	Bit 8	00h	0h	0b	HPOUT1R_ENA = 0 HPOUT1L_ENA = 0 (delay = 0.5625ms)
37 (25h)	R76 (4Ch)	1 bit	Bit 15	00h	0h	0b	CP_ENA = 0 (delay = 0.5625ms)
38 (26h)	R1 (01h)	2 bits	Bit 12	00h	0h	0b	SPKOUTL_ENA = 0 SPKOUTR_ENA = 0 (delay = 0.5625ms)
39 (27h)	R57 (39h)	6 bits	Bit 1	37h	0h	0b	BIAS_SRC = 1 STARTUP_BIAS_ENA = 1 VMID_BUF_ENA = 1 VMID_RAMP[1:0] = 11b (delay = 0.5625ms)
40 (28h)	R1 (01h)	3 bits	Bit 0	00h	9h	0b	BIAS_ENA = 0 VMID_SEL = 00b (delay = 32.5ms)
41 (29h)	R57 (39h)	6 bits	Bit 1	00h	0h	1b	BIAS_SRC = 0 STARTUP_BIAS_ENA = 0 VMID_BUF_ENA = 0 VMID_RAMP[1:0] = 00b (delay = 0.5625ms)

Table 136 Speaker and Headphone Fast Shut-Down Default Sequence

Generic Shut-Down

The Generic Shut-Down sequence can be initiated by writing 812Ah to Register 272 (0110h). This single operation starts the Control Write Sequencer at Index Address 42 (2Ah) and executes the sequence defined in Table 137.

This sequence takes approximately 522ms to run.

WSEQ INDEX	REGISTER ADDRESS	WIDTH	START	DATA	DELAY	EOS	DESCRIPTION
42 (2Ah)	R31 (1Fh)	1 bit	Bit 5	01h	0h	0b	HPOUT2_MUTE = 1 (delay = 0.5625ms)
43 (2Bh)	R30 (1Eh)	6 bits	Bit 1	33h	0h	0b	LINEOUT2P_MUTE = 1 LINEOUT2N_MUTE = 1 LINEOUT1P_MUTE = 1 LINEOUT1N_MUTE = 1 (delay = 0.5625ms)
44 (2Ch)	R96 (60h)	7 bits	Bit 1	00h	0h	0b	HPOUT1R_DLY = 0 HPOUT1R_OUTP = 0 HPOUT1R_RMV_SHORT = 0 HPOUT1L_DLY = 0 HPOUT1L_OUTP = 0 HPOUT1L_RMV_SHORT = 0 (delay = 0.5625ms)
45 (2Dh)	R84 (54h)	2 bits	Bit 0	00h	0h	0b	DCS_ENA_CHAN_0 = 0 DCS_ENA_CHAN_1 = 0 (delay = 0.5625ms)
46 (2Eh)	R1 (01h)	2 bits	Bit 8	00h	0h	0b	HPOUT1R_ENA = 0 HPOUT1L_ENA = 0 (delay = 0.5625ms)
47 (2Fh)	R76 (4Ch)	1 bit	Bit 15	00h	0h	0b	CP_ENA = 0 (delay = 0.5625ms)
48 (30h)	R1 (01h)	2 bits	Bit 12	00h	0h	0b	SPKOUTL_ENA = 0 SPKOUTR_ENA = 0 (delay = 0.5625ms)
49 (31h)	R57 (39h)	6 bits	Bit 1	17h	0h	0b	BIAS_SRC = 1 STARTUP_BIAS_ENA = 1 VMID_BUF_ENA = 1 VMID_RAMP[1:0] = 01b (delay = 0.5625ms)
50 (32h)	R1 (01h)	3 bits	Bit 0	00h	Dh	0b	BIAS_ENA = 0 VMID_SEL = 00b (delay = 512.5ms)
51 (33h)	R1 (01h)	1 bit	Bit 11	00h	0h	0b	HPOUT2_ENA = 0 (delay = 0.5625ms)
52 (34h)	R56 (38h)	2 bits	Bit 4	03h	0h	0b	LINEOUT2_DISCH = 1 LINEOUT1_DISCH = 1 (delay = 0.5625ms)
53 (35h)	R55 (37h)	1 bit	Bit 0	01h	0h	0b	VROI = 1 (delay = 0.5625ms)
54 (36h)	R56 (38h)	1 bit	Bit 6	00h	0h	0b	HPOUT2_IN_ENA = 0 (delay = 0.5625ms)
55 (37h)	R3 (03h)	4 bits	Bit 10	00h	0h	0b	LINEOUT2P_ENA = 0 LINEOUT2N_ENA = 0 LINEOUT1P_ENA = 0 LINEOUT1N_ENA = 0 (delay = 0.5625ms)

WSEQ INDEX	REGISTER ADDRESS	WIDTH	START	DATA	DELAY	EOS	DESCRIPTION
56 (38h)	R56 (38h)	1 bit	Bit 7	00h	0h	0b	LINEOUT_VMID_BUF_ENA = 0 (delay = 0.5625ms)
57 (39h)	R55 (37h)	1 bit	Bit 0	00h	0h	0b	VROI = 0 (delay = 0.5625ms)
58 (3Ah)	R57 (39h)	6 bits	Bit 1	00h	0h	1b	BIAS_SRC = 0 STARTUP_BIAS_ENA = 0 VMID_BUF_ENA = 0 VMID_RAMP[1:0] = 00b (delay = 0.5625ms)

Table 137 Generic Shut-Down Default Sequence

POP SUPPRESSION CONTROL

The WM8958 incorporates a number of features, including Wolfson's SilentSwitch™ technology, designed to suppress pops normally associated with Start-Up, Shut-Down or signal path control. To achieve maximum benefit from these features, careful attention is required to the sequence and timing of these controls. Note that, under the recommended usage conditions of the WM8958, these features will be configured by running the default Start-Up and Shut-Down sequences as described in the "Control Write Sequencer" section. In these cases, the user does not need to set these register fields directly.

The Pop Suppression controls relating to the Headphone / Line Output drivers are described in the "Analogue Output Signal Path" section.

Additional bias controls, also pre-programmed into Control Write Sequencer, are described in the "Reference Voltages and Master Bias" section.

DISABLED LINE OUTPUT CONTROL

The line outputs are biased to VMID in normal operation. To avoid audible pops caused by a disabled signal path dropping to AGND, the WM8958 can maintain these connections at VMID when the relevant output stage is disabled. This is achieved by connecting a buffered VMID reference to the output.

The buffered VMID reference is enabled by setting VMID_BUF_ENA. The output resistance is selectable, using the VROI register bit.

Note that, if LINEOUTn_DISCH=1 (see Table 139), then the respective output will be discharged to AGND, and will not be connected to VMID.

REGISTER ADDRESS	BIT	LABEL	DEFAULT	DESCRIPTION
R55 (0037h) Additional Control	0	VROI	0	Buffered VMID to Analogue Line Output Resistance (Disabled Outputs) 0 = 20kΩ from buffered VMID to output 1 = 500Ω from buffered VMID to output
R57 (0039h) AntiPOP (2)	3	VMID_BUF_ENA	0	VMID Buffer Enable 0 = Disabled 1 = Enabled (provided VMID_SEL > 00)

Table 138 Disabled Line Output Control

LINE OUTPUT DISCHARGE CONTROL

The line output paths can be actively discharged to AGND through internal resistors if desired. This is desirable at start-up in order to achieve a known output stage condition prior to enabling the soft-start VMID reference voltage. This is also desirable in shut-down to prevent the external connections from being affected by the internal circuits.

The line outputs LINEOUT1P and LINEOUT1N are discharged to AGND by setting LINEOUT1_DISCH. The line outputs LINEOUT2P and LINEOUT2N are discharged to AGND by setting LINEOUT2_DISCH.

The discharge resistance is dependent upon the respective LINEOUTn_ENA bit, and also according to the VROI bit (see Table 138). The discharge resistance is noted in the “Electrical Characteristics” section.

REGISTER ADDRESS	BIT	LABEL	DEFAULT	DESCRIPTION
R56 (0038h) AntiPOP (1)	5	LINEOUT1_DISCH H	0	Discharges LINEOUT1P and LINEOUT1N outputs 0 = Not active 1 = Actively discharging LINEOUT1P and LINEOUT1N
	4	LINEOUT2_DISCH H	0	Discharges LINEOUT2P and LINEOUT2N outputs 0 = Not active 1 = Actively discharging LINEOUT2P and LINEOUT2N

Table 139 Line Output Discharge Control

VMID REFERENCE DISCHARGE CONTROL

The VMID reference can be actively discharged to AGND through internal resistors. This is desirable at start-up in order to achieve a known initial condition prior to enabling the soft-start VMID reference; this ensures maximum suppression of audible pops associated with start-up. VMID is discharged by setting VMID_DISCH.

REGISTER ADDRESS	BIT	LABEL	DEFAULT	DESCRIPTION
R57 (0039h) AntiPOP (2)	0	VMID_DISCH	0	Connects VMID to ground 0 = Disabled 1 = Enabled

Table 140 VMID Reference Discharge Control

INPUT VMID CLAMPS

The analogue inputs can be clamped to Vmid using the INPUTS_CLAMP bit described below. This allows pre-charging of the input AC coupling capacitors during power-up. Note that all eight inputs are clamped using the same control bit.

Note that INPUTS_CLAMP must be set to 0 when the analogue input signal paths are in use.

REGISTER ADDRESS	BIT	LABEL	DEFAULT	DESCRIPTION
R21 (15h) Input Mixer (1)	6	INPUTS_CLAMP	0	Input pad VMID clamp 0 = Clamp de-activated 1 = Clamp activated

Table 141 Input VMID Clamps

LDO REGULATORS

The WM8958 provides two integrated Low Drop-Out Regulators (LDOs). These are provided to generate the appropriate power supplies for internal circuits, simplifying and reducing the requirements for external supplies and associated components. A reference circuit powered by AVDD2 ensures the accuracy of the LDO regulator voltage settings.

Note that the integrated LDOs are only intended for generating the AVDD1 and DCVDD supply rails for the WM8958; they are not suitable for powering any additional or external loads.

LDO1 is intended for generating AVDD1 - the primary analogue power domain of the WM8958. LDO1 is powered by LDO1VDD and is enabled when a logic '1' is applied to the LDO1ENA pin. The logic level is determined with respect to the DBVDD1 voltage domain. The LDO1 start-up time is dependent on the external AVDD1 and VREFC capacitors; the start-up time is noted in the "Electrical Characteristics" section for the recommended external component conditions.

When LDO1 is enabled, the output voltage is controlled by the LDO1_VSEL register field. Note that the LDO1 voltage difference LDO1VDD - AVDD1 must be higher than the LDO1 Drop-Out voltage (see "Electrical Characteristics").

When LDO1 is disabled (by applying a logic '0' to the LDO1ENA pin), the output can be left floating or can be actively discharged, depending on the LDO1_DISCH control bit.

It is possible to supply AVDD1 from an external supply. If AVDD1 is supplied externally, then LDO1 should be disabled, and the LDO1 output left floating (LDO1DISCH = 0). Note that the LDO1VDD voltage must be greater than or equal to AVDD1; this ensures that there is no leakage path through the LDO for the external supply.

Note that the WM8958 can operate with AVDD1 tied to 0V; power consumption may be reduced, but the analogue audio functions will not be supported.

LDO2 is intended for generating the DCVDD power domain which supplies the digital core functions on the WM8958. LDO2 is powered by DBVDD1 and is enabled when a logic '1' is applied to the LDO2ENA pin. The logic level is determined with respect to the DBVDD1 voltage domain. The LDO2 start-up time is dependent on the external DCVDD and VREFC capacitors; the start-up time is noted in the "Electrical Characteristics" section for the recommended external component conditions.

When LDO2 is enabled, the output voltage is controlled by the LDO2_VSEL register field.

When LDO2 is disabled (by applying a logic '0' to the LDO2ENA pin), the output can be left floating or can be actively discharged, depending on the LDO2_DISCH control bit.

It is possible to supply DCVDD from an external supply. If DCVDD is supplied externally, the LDO2ENA and LDO2DISCH bits should be set to 0. Note that the DBVDD1 voltage must be greater than or equal to DCVDD; this ensures that there is no leakage path through the LDO for the external supply.

An internal pull-down resistor is enabled by default on the LDO1ENA and LDO2ENA pins. These pull-down resistors can be configured using the register bits described in Table 142.

Decoupling capacitors should be connected to the voltage reference pin, VREFC, and also to the LDO outputs, AVDD1 and DCVDD. See "Applications Information" for further details.

The LDO Regulator connections and controls are illustrated in Figure 81. The register controls are defined in Table 142.

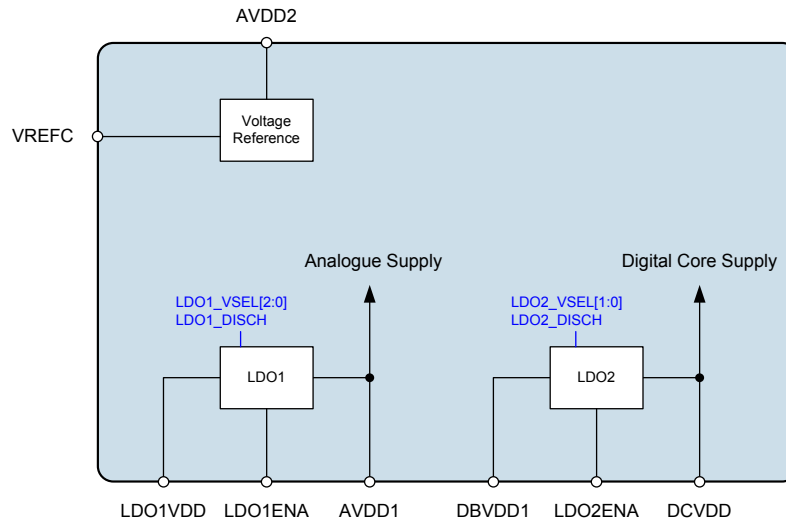

Figure 81 LDO Regulators

REGISTER ADDRESS	BIT	LABEL	DEFAULT	DESCRIPTION
R59 (003Bh) LDO 1	3:1	LDO1_VSEL [2:0]	110	LDO1 Output Voltage Select 2.4V to 3.1V in 100mV steps 000 = 2.4V 001 = 2.5V 010 = 2.6V 011 = 2.7V 100 = 2.8V 101 = 2.9V 110 = 3.0V 111 = 3.1V
	0	LDO1_DISCH	1	LDO1 Discharge Select 0 = LDO1 floating when disabled 1 = LDO1 discharged when disabled
R60 (003Ch) LDO 2	2:1	LDO2_VSEL [1:0]	10	LDO2 Output Voltage Select 1.1V to 1.3V in 100mV steps 00 = Reserved 01 = 1.1V 10 = 1.2V 11 = 1.3V
	0	LDO2_DISCH	1	LDO2 Discharge Select 0 = LDO2 floating when disabled 1 = LDO2 discharged when disabled
R1825 (0721h) Pull Control (2)	6	LDO2ENA_PD	1	LDO2ENA Pull-down enable 0 = Disabled 1 = Enabled
	4	LDO1ENA_PD	1	LDO1ENA Pull-down enable 0 = Disabled 1 = Enabled

Table 142 LDO Regulator Control

REFERENCE VOLTAGES AND MASTER BIAS

This section describes the analogue reference voltage and bias current controls. It also describes the VMID soft-start circuit for pop suppressed start-up and shut-down.

The analogue circuits in the WM8958 require a mid-rail analogue reference voltage, VMID. This reference is generated from AVDD1 via a programmable resistor chain. Together with the external VMID decoupling capacitor, the programmable resistor chain determines the charging characteristic on VMID. This is controlled by VMID_SEL[1:0], and can be used to optimise the reference for normal operation or low power standby as described in Table 143.

A buffered mid-rail reference voltage is provided. This is required for the single-ended configuration of the Input PGAs, and also for direct signal paths from the input pins to the Input Mixers, Output Mixers or Speaker Mixers. These requirements are noted in the relevant "Analogue Input Signal Path" and "Analogue Output Signal Path" sections. The buffered mid-rail reference is enabled by setting the VMID_BUF_ENA register bit.

The analogue circuits in the WM8958 require a bias current. The normal bias current is enabled by setting BIAS_ENA. Note that the normal bias current source requires VMID to be enabled also.

REGISTER ADDRESS	BIT	LABEL	DEFAULT	DESCRIPTION
R1 (0001h) Power Management (1)	2:1	VMID_SEL [1:0]	00	VMID Divider Enable and Select 00 = VMID disabled (for OFF mode) 01 = 2 x 40kΩ divider (for normal operation) 10 = 2 x 240kΩ divider (for low power standby) 11 = Reserved
	0	BIAS_ENA	0	Enables the Normal bias current generator (for all analogue functions) 0 = Disabled 1 = Enabled
R57 (0039h) AntiPOP (2)	3	VMID_BUF_ENA	0	VMID Buffer Enable 0 = Disabled 1 = Enabled (provided VMID_SEL > 00)

Table 143 Reference Voltages and Master Bias Enable

A pop-suppressed start-up requires VMID to be enabled smoothly, without the step change normally associated with the initial stage of the VMID capacitor charging. A pop-suppressed start-up also requires the analogue bias current to be enabled throughout the signal path prior to the VMID reference voltage being applied. The WM8958 incorporates pop-suppression circuits which address these requirements.

An alternate bias current source (Start-Up Bias) is provided for pop-free start-up; this is enabled by the STARTUP_BIAS_ENA register bit. The start-up bias is selected (in place of the normal bias) using the BIAS_SRC bit. It is recommended that the start-up bias is used during start-up, before switching back to the higher quality, normal bias.

A soft-start circuit is provided in order to control the switch-on of the VMID reference. The soft-start control circuit offers two slew rates for enabling the VMID reference; these are selected and enabled by VMID_RAMP. When the soft-start circuit is enabled prior to enabling VMID_SEL, the reference voltage rises smoothly, without the step change that would otherwise occur. It is recommended that the soft-start circuit and the output signal path be enabled before VMID is enabled by VMID_SEL.

A soft shut-down is provided, using the soft-start control circuit and the start-up bias current generator. The soft shut-down of VMID is achieved by setting VMID_RAMP, STARTUP_BIAS_ENA and BIAS_SRC to select the start-up bias current and soft-start circuit prior to setting VMID_SEL=00.

Note that, if the VMID_RAMP function is enabled for soft start-up or soft shut-down then, after setting VMID_SEL = 00 to disable VMID, the soft-start circuit must be reset before re-enabling VMID. The soft-start circuit is reset by setting VMID_RAMP = 00. After resetting the soft-start circuit, the VMID_RAMP register may be updated to the required setting for the next VMID transition.

The VMID soft-start register controls are defined in Table 144.

REGISTER ADDRESS	BIT	LABEL	DEFAULT	DESCRIPTION
R57 (0039h) AntiPOP (2)	6:5	VMID_RAMP [1:0]	10	VMID soft start enable / slew rate control 00 = Normal slow start 01 = Normal fast start 10 = Soft slow start 11 = Soft fast start If VMID_RAMP = 1X is selected for VMID start-up or shut-down, then the soft-start circuit must be reset by setting VMID_RAMP=00 after VMID is disabled, before VMID is re-enabled. VMID is disabled / enabled using the VMID_SEL register.
	2	STARTUP_BIAS_ENA	0	Enables the Start-Up bias current generator 0 = Disabled 1 = Enabled
	1	BIAS_SRC	1	Selects the bias current source 0 = Normal bias 1 = Start-Up bias

Table 144 Soft Start Control

POWER MANAGEMENT

The WM8958 has control registers that allow users to select which functions are active. For minimum power consumption, unused functions should be disabled. To minimise pop or click noise, it is important to enable or disable functions in the correct order. See “Control Write Sequencer” for details of recommended control sequences.

REGISTER ADDRESS	BIT	LABEL	DEFAULT	DESCRIPTION
R1 (0001h) Power Management (1)	13	SPKOUTR_ENA	0	SPKMIXR Mixer, SPKRVOL PGA and SPKOUTR Output Enable 0 = Disabled 1 = Enabled
	12	SPKOUTL_ENA	0	SPKMIXL Mixer, SPKLVOL PGA and SPKOUTL Output Enable 0 = Disabled 1 = Enabled
	11	HPOUT2_ENA	0	HPOUT2 and HPOUT2MIX Enable 0 = Disabled 1 = Enabled
	9	HPOUT1L_ENA	0	Enables HPOUT1L input stage 0 = Disabled 1 = Enabled
	8	HPOUT1R_ENA	0	Enables HPOUT1R input stage 0 = Disabled 1 = Enabled
	5	MICB2_ENA	0	Microphone Bias 2 Enable 0 = Disabled 1 = Enabled
	4	MICB1_ENA	0	Microphone Bias 1 Enable 0 = Disabled 1 = Enabled
	2:1	VMID_SEL [1:0]	00	VMID Divider Enable and Select 00 = VMID disabled (for OFF mode) 01 = 2 x 40kΩ divider (Normal mode) 10 = 2 x 240kΩ divider (Standby mode) 11 = Reserved
	0	BIAS_ENA	0	Enables the Normal bias current generator (for all analogue functions) 0 = Disabled 1 = Enabled
R2 (0002h) Power Management (2)	14	TSHUT_ENA	1	Thermal Sensor Enable 0 = Disabled 1 = Enabled
	13	TSHUT_OPDIS	1	Thermal Shutdown Control (Causes audio outputs to be disabled if an over-temperature occurs. The thermal sensor must also be enabled.) 0 = Disabled 1 = Enabled
	11	OPCLK_ENA	0	GPIO Clock Output (OPCLK) Enable 0 = Disabled 1 = Enabled
	9	MIXINL_ENA	0	Left Input Mixer Enable (Enables MIXINL and RXVOICE input to MIXINL) 0 = Disabled 1 = Enabled

REGISTER ADDRESS	BIT	LABEL	DEFAULT	DESCRIPTION
	8	MIXINR_ENA	0	Right Input Mixer Enable (Enables MIXINR and RXVOICE input to MIXINR) 0 = Disabled 1 = Enabled
	7	IN2L_ENA	0	IN2L Input PGA Enable 0 = Disabled 1 = Enabled
	6	IN1L_ENA	0	IN1L Input PGA Enable 0 = Disabled 1 = Enabled
	5	IN2R_ENA	0	IN2R Input PGA Enable 0 = Disabled 1 = Enabled
	4	IN1R_ENA	0	IN1R Input PGA Enable 0 = Disabled 1 = Enabled
R3 (0003h) Power Management (3)	13	LINEOUT1N_ENA	0	LINEOUT1N Line Out and LINEOUT1NMIX Enable 0 = Disabled 1 = Enabled
	12	LINEOUT1P_ENA	0	LINEOUT1P Line Out and LINEOUT1PMIX Enable 0 = Disabled 1 = Enabled
	11	LINEOUT2N_ENA	0	LINEOUT2N Line Out and LINEOUT2NMIX Enable 0 = Disabled 1 = Enabled
	10	LINEOUT2P_ENA	0	LINEOUT2P Line Out and LINEOUT2PMIX Enable 0 = Disabled 1 = Enabled
	9	SPKRVOL_ENA	0	SPKMIXR Mixer and SPKRVOL PGA Enable 0 = Disabled 1 = Enabled Note that SPKMIXR and SPKRVOL are also enabled when SPKOUTR_ENA is set.
	8	SPKLVOL_ENA	0	SPKMIXL Mixer and SPKLVOL PGA Enable 0 = Disabled 1 = Enabled Note that SPKMIXL and SPKLVOL are also enabled when SPKOUTL_ENA is set.
	7	MIXOUTLVOL_ENA	0	MIXOUTL Left Volume Control Enable 0 = Disabled 1 = Enabled
	6	MIXOUTRVOL_ENA	0	MIXOUTR Right Volume Control Enable 0 = Disabled 1 = Enabled
	5	MIXOUTL_ENA	0	MIXOUTL Left Output Mixer Enable 0 = Disabled

REGISTER ADDRESS	BIT	LABEL	DEFAULT	DESCRIPTION
				1 = Enabled
	4	MIXOUTR_ENA	0	MIXOUTR Right Output Mixer Enable 0 = Disabled 1 = Enabled
R4 (0004h) Power Management (4)	13	AIF2ADCL_ENA	0	Enable AIF2ADC (Left) output path 0 = Disabled 1 = Enabled This bit must be set for AIF2 or AIF3 output of the AIF2ADC (Left) signal.
	12	AIF2ADCR_ENA	0	Enable AIF2ADC (Right) output path 0 = Disabled 1 = Enabled This bit must be set for AIF2 or AIF3 output of the AIF2ADC (Left) signal.
	11	AIF1ADC2L_ENA	0	Enable AIF1ADC2 (Left) output path (AIF1, Timeslot 1) 0 = Disabled 1 = Enabled
	10	AIF1ADC2R_ENA	0	Enable AIF1ADC2 (Right) output path (AIF1, Timeslot 1) 0 = Disabled 1 = Enabled
	9	AIF1ADC1L_ENA	0	Enable AIF1ADC1 (Left) output path (AIF1, Timeslot 0) 0 = Disabled 1 = Enabled
	8	AIF1ADC1R_ENA	0	Enable AIF1ADC1 (Right) output path (AIF1, Timeslot 0) 0 = Disabled 1 = Enabled
	5	DMIC2L_ENA	0	Digital microphone DMICDAT2 Left channel enable 0 = Disabled 1 = Enabled
	4	DMIC2R_ENA	0	Digital microphone DMICDAT2 Right channel enable 0 = Disabled 1 = Enabled
	3	DMIC1L_ENA	0	Digital microphone DMICDAT1 Left channel enable 0 = Disabled 1 = Enabled
	2	DMIC1R_ENA	0	Digital microphone DMICDAT1 Right channel enable 0 = Disabled 1 = Enabled
	1	ADCL_ENA	0	Left ADC Enable 0 = ADC disabled 1 = ADC enabled
	0	ADCR_ENA	0	Right ADC Enable 0 = ADC disabled 1 = ADC enabled
R5 (0005h) Power Management	13	AIF2DACL_ENA	0	Enable AIF2DAC (Left) input path 0 = Disabled 1 = Enabled

REGISTER ADDRESS	BIT	LABEL	DEFAULT	DESCRIPTION
(5)	12	AIF2DACR_ENA	0	Enable AIF2DAC (Right) input path 0 = Disabled 1 = Enabled
	11	AIF1DAC2L_ENA	0	Enable AIF1DAC2 (Left) input path (AIF1, Timeslot 1) 0 = Disabled 1 = Enabled
	10	AIF1DAC2R_ENA	0	Enable AIF1DAC2 (Right) input path (AIF1, Timeslot 1) 0 = Disabled 1 = Enabled
	9	AIF1DAC1L_ENA	0	Enable AIF1DAC1 (Left) input path (AIF1, Timeslot 0) 0 = Disabled 1 = Enabled
	8	AIF1DAC1R_ENA	0	Enable AIF1DAC1 (Right) input path (AIF1, Timeslot 0) 0 = Disabled 1 = Enabled
	3	DAC2L_ENA	0	Left DAC2 Enable 0 = DAC disabled 1 = DAC enabled
	2	DAC2R_ENA	0	Right DAC2 Enable 0 = DAC disabled 1 = DAC enabled
	1	DAC1L_ENA	0	Left DAC1 Enable 0 = DAC disabled 1 = DAC enabled
	0	DAC1R_ENA	0	Right DAC1 Enable 0 = DAC disabled 1 = DAC enabled
R76 (004Ch) Charge Pump (1)	15	CP_ENA	0	Enable charge-pump digits 0 = Disable 1 = Enable
R84 (0054h) DC Servo (1)	1	DCS_ENA_CHAN_1	0	DC Servo enable for HPOUT1R 0 = Disabled 1 = Enabled
	0	DCS_ENA_CHAN_0	0	DC Servo enable for HPOUT1L 0 = Disabled 1 = Enabled
R272 (0110h) Write Sequencer Ctrl (1)	8	WSEQ_ENA	0	Write Sequencer Enable. 0 = Disabled 1 = Enabled
R512 (0200h) AIF 1 Clocking (1)	0	AIF1CLK_ENA	0	AIF1CLK Enable 0 = Disabled 1 = Enabled
R516 (0204h) AIF 2 Clocking (1)	0	AIF2CLK_ENA	0	AIF2CLK Enable 0 = Disabled 1 = Enabled
R520 (0208h) Clocking (1)	4	TOCLK_ENA	0	Slow Clock (TOCLK) Enable 0 = Disabled 1 = Enabled This clock is required for zero-cross timeout.

REGISTER ADDRESS	BIT	LABEL	DEFAULT	DESCRIPTION
	3	AIF1DSPCLK_EN A	0	AIF1 Processing Clock Enable 0 = Disabled 1 = Enabled
	2	AIF2DSPCLK_EN A	0	AIF2 Processing Clock Enable 0 = Disabled 1 = Enabled
	1	SYSDSPCLK_EN A	0	Digital Mixing Processor Clock Enable 0 = Disabled 1 = Enabled
R544 (0220h) FLL1 Control (1)	0	FLL1_ENA	0	FLL1 Enable 0 = Disabled 1 = Enabled This should be set as the final step of the FLL1 enable sequence, ie. after the other FLL registers have been configured.
R576 (0240h) FLL2 Control (1)	0	FLL2_ENA	0	FLL2 Enable 0 = Disabled 1 = Enabled This should be set as the final step of the FLL2 enable sequence, ie. after the other FLL registers have been configured.

Table 145 Power Management

THERMAL SHUTDOWN

The WM8958 incorporates a temperature sensor which detects when the device temperature is within normal limits or if the device is approaching a hazardous temperature condition. The temperature sensor can be configured to automatically disable the audio outputs of the WM8958 in response to an overtemperature condition (approximately 150°C).

The temperature status can be output directly on a GPIO pin, as described in the “General Purpose Input/Output” section. The temperature sensor can also be used to generate Interrupt events, as described in the “Interrupts” section. The GPIO and Interrupt functions can be used to indicate either a Warning Temperature event or the Shutdown Temperature event.

The temperature sensor is enabled by setting the TSHUT_ENA register bit. When the TSHUT_OPDIS is also set, then a device over-temperature condition will cause the speaker outputs (SPKOUTL and SPKOUTR) of the WM8958 to be disabled; this response is likely to prevent any damage to the device attributable to the large currents of the output drivers.

Note that, to prevent pops and clicks, TSHUT_ENA and TSHUT_OPDIS should only be updated whilst the speaker and headphone outputs are disabled.

REGISTER ADDRESS	BIT	LABEL	DEFAULT	DESCRIPTION
R2 (0002h) Power Management (2)	14	TSHUT_ENA	1	Thermal sensor enable 0 = Disabled 1 = Enabled
	13	TSHUT_OPDIS	1	Thermal shutdown control (Causes audio outputs to be disabled if an overtemperature occurs. The thermal sensor must also be enabled.) 0 = Disabled 1 = Enabled

Table 146 Thermal Shutdown

POWER ON RESET

The WM8958 includes a Power-On Reset (POR) circuit, which is used to reset the digital logic into a default state after power up. The POR circuit derives its output from AVDD2 and DCVDD. The internal $\overline{\text{POR}}$ signal is asserted low when AVDD2 and DCVDD are below minimum thresholds.

The specific behaviour of the circuit will vary, depending on relative timing of the supply voltages. Typical scenarios are illustrated in Figure 82 and Figure 83.

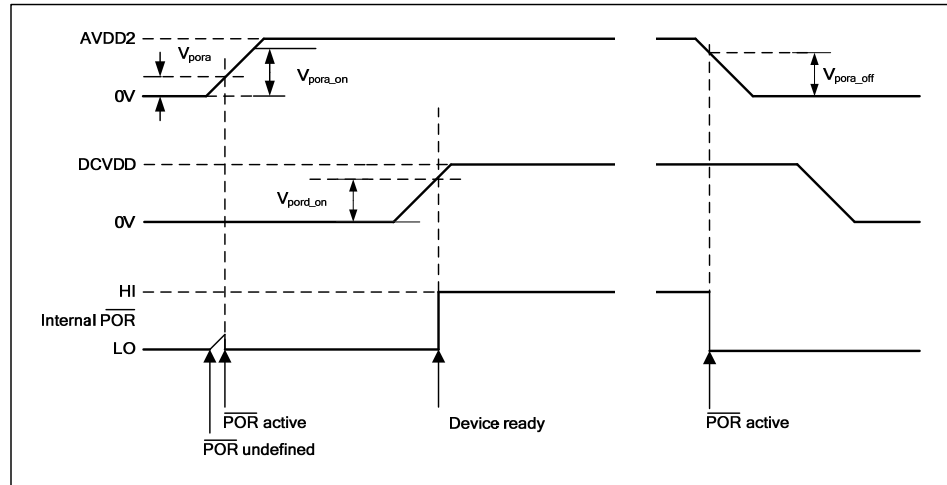

Figure 82 Power On Reset Timing – AVDD2 enabled/disabled first

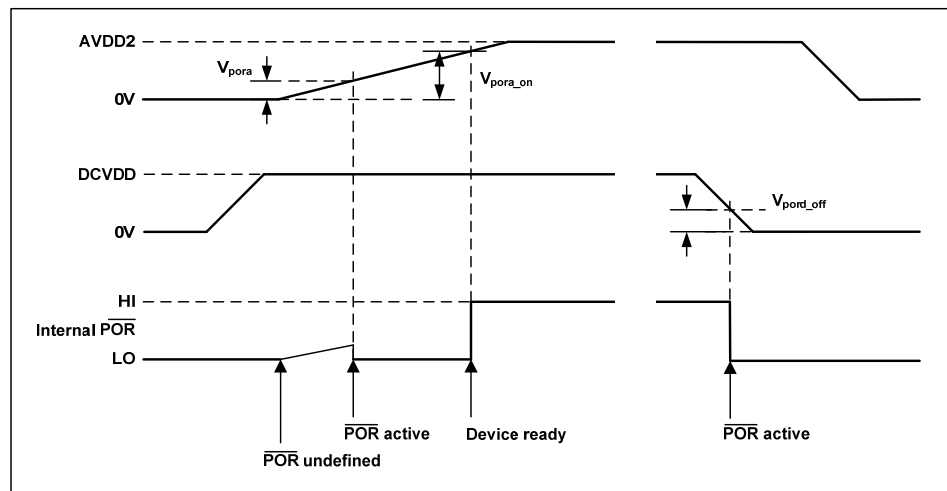

Figure 83 Power On Reset Timing - DCVDD enabled/disabled first

The $\overline{\text{POR}}$ signal is undefined until AVDD2 has exceeded the minimum threshold, V_{pora} . Once this threshold has been exceeded, $\overline{\text{POR}}$ is asserted low and the chip is held in reset. In this condition, all writes to the control interface are ignored. Once AVDD2 and DCVDD have reached their respective power on thresholds, $\overline{\text{POR}}$ is released high, all registers are in their default state, and writes to the control interface may take place.

Note that a power-on reset period, T_{POR} , applies after AVDD2 and DCVDD have reached their respective power on thresholds. This specification is guaranteed by design rather than test.

On power down, $\overline{\text{POR}}$ is asserted low when either AVDD2 or DCVDD falls below their respective power-down thresholds.

Typical Power-On Reset parameters for the WM8958 are defined in Table 147.

SYMBOL	DESCRIPTION	TYP	UNIT
V _{pora_on}	Power-On threshold (AVDD2)	1.15	V
V _{pora_off}	Power-Off threshold (AVDD2)	1.14	V
V _{pard_on}	Power-On threshold (DCVDD)	0.56	V
V _{pard_off}	Power-Off threshold (DCVDD)	0.55	V
T _{POR}	Minimum Power-On Reset period	100	ns

Table 147 Typical Power-On Reset Parameters

Table 148 describes the status of the WM8958 digital I/O pins when the Power On Reset has completed, prior to any register writes. The same conditions apply on completion of a Software Reset (described in the “Software Reset and Device ID” section).

PIN NO	NAME	TYPE	RESET STATUS
DBVDD1 power domain			
A4	SPKMODE	Digital Input	Pull-up to DBVDD1
C3	LDO1ENA	Digital Input	Pull-down to DGND
D3	ADDR	Digital Input	Pull-down to DGND
D5	LDO2ENA	Digital Input	Pull-down to DGND
E3	SCLK	Digital Input	Digital input
G2	SDA	Digital Input/Output	Digital input
E1	MCLK1	Digital Input	Digital input
D2	MCLK2	Digital Input	Pull-down to DGND
F2	BCLK1	Digital Input/Output	Digital input
D4	LRCLK1	Digital Input/Output	Digital input
H1	GPIO1/ADCLRCLK1	Digital Input/Output	Digital input
G1	DACDAT1	Digital Input	Digital input
F1	ADCDAT1	Digital Output	Digital output
DBVDD2 power domain			
G3	BCLK2	Digital Input/Output	Digital input, Pull-down to DGND
H2	LRCLK2	Digital Input/Output	Digital input, Pull-down to DGND
H3	GPIO6/ADCLRCLK2	Digital Input/Output	Digital input, Pull-down to DGND
E4	DACDAT2	Digital Input	Pull-down to DGND
F4	ADCDAT2	Digital Output	Digital output
DBVDD3 power domain			
E5	GPIO11/BCLK3	Digital Input/Output	Digital input, Pull-down to DGND
F5	GPIO10/LRCLK3	Digital Input/Output	Digital input, Pull-down to DGND
G4	GPIO8/DACDAT3	Digital Input/Output	Digital input, Pull-down to DGND
H4	GPIO9/ADCDAT3	Digital Input/Output	Digital input, Pull-down to DGND
MICBIAS1 power domain			
D6	DMICCLK	Digital Output	Digital output
A8	IN2RN/DMICDAT2	Analogue Input/Digital Input	Analogue input
B9	IN2LN/DMICDAT1	Analogue Input/Digital Input	Analogue input

Table 148 WM8958 Digital I/O Status in Reset

Note that the dual function IN2LN/DMICDAT1 and IN2RN/DMICDAT2 pins default to IN2LN or IN2RN (analogue input) after Power On Reset is completed. The IN2LN and IN2RN functions are referenced to the AVDD1 power domain.

QUICK START-UP AND SHUTDOWN

The default control sequences (see “Control Write Sequencer”) contain only the register writes necessary to enable or disable specific output drivers. It is therefore necessary to configure the signal path and gain settings before commanding any of the default start-up sequences.

This section describes minimum control sequences to configure the WM8958 for DAC to Headphone playback. Note that these sequences are provided for guidance only; application software should be verified and tailored to ensure optimum performance.

Table 149 describes an example control sequence to enable DAC playback to HPOUT1L and HPOUT1R path. This involves DAC enable, signal path configuration and mute control, together with the default “Headphone Cold Start-Up” sequence. Table 150 describes an example control sequence to disable the direct DAC to Headphone path.

REGISTER	VALUE	DESCRIPTION
R5 (0005h)	0003h	Enable DAC1L and DAC1R
R45 (002Dh)	0100h	Enable path from DAC1L to HPOUT1L
R46 (002Eh)	0100h	Enable path from DAC1R to HPOUT1R
R272 (0110h)	8100h	Initiate Control Write Sequencer at Index Address 0 (00h) (Headphone Cold Start-Up sequence)
		Delay 300ms Note: Delay must be inserted in the sequence to allow the Control Write Sequencer to finish. Any control interface writes to the CODEC will be ignored while the Control Write Sequencer is running.
R1056 (0420h)	0000h	Soft un-mute DAC1L and DAC1R

Table 149 DAC to Headphone Direct Start-Up Sequence

REGISTER	VALUE	DESCRIPTION
R1056 (0420h)	0200h	Soft mute DAC1L and DAC1R
R272 (0110h)	812Ah	Initiate Control Write Sequencer at Index Address 42 (2Ah) (Generic Shut-Down)
		Delay 525ms Note: Delay must be inserted in the sequence to allow the Control Write Sequencer to finish. Any control interface writes to the CODEC will be ignored while the Control Write Sequencer is running.
R45 (002Dh)	0000h	Disable path from DAC1L to HPOUT1L
R46 (002Eh)	0000h	Disable path from DAC1R to HPOUT1R
R5 (0005h)	0000h	Disable DAC1L and DAC1R

Table 150 DAC to Headphone Direct Shut-Down Sequence

In both cases, the WSEQ_BUSY bit (in Register R272, see Table 129) will be set to 1 while the Control Write Sequence runs. When this bit returns to 0, the remaining steps of the sequence may be executed.

SOFTWARE RESET AND DEVICE ID

The device ID can be read back from register R0. Writing to this register will reset the device.

The software reset causes most control registers to be reset to their default state. Note that the Control Write Sequencer registers R12288 (3000h) through to R12799 (31FFh) are not affected by a software reset; the Control Sequences defined in these registers are retained unchanged.

The status of the WM8958 digital I/O pins following a software reset is described in Table 148.

The device revision can be read back from register R256.

REGISTER ADDRESS	BIT	LABEL	DEFAULT	DESCRIPTION
R0 (0000h) Software Reset	15:0	SW_RESET [15:0]	8958h	Writing to this register resets all registers to their default state. (Note - Control Write Sequencer registers are not affected by Software Reset.) Reading from this register will indicate device ID 8958h.
R256 (0100h) Chip Revision	3:0	CHIP_REV [3:0]		Chip revision

Table 151 Chip Reset and ID

REGISTER MAP

The WM8958 control registers are listed below. Note that only the register addresses described here should be accessed; writing to other addresses may result in undefined behaviour. Register bits that are not documented should not be changed from the default values.

REG	NAME	15	14	13	12	11	10	9	8	7	6	5	4	3	2	1	0	DEFAULT
R0 (0h)	Software Reset	SW_RESET [15:0]																0000h
R1 (1h)	Power Management (1)	0	0	SPKOUTR_ENA	SPKOUTL_ENA	HPOUT2_ENA	0	HPOUT1L_ENA	HPOUT1R_ENA	0	0	MICB2_ENA	MICB1_ENA	0	VMID_SEL [1:0]		BIAS_ENA	0000h
R2 (2h)	Power Management (2)	0	TSHUT_ENA	TSHUT_OPDIS	0	OPCLK_ENA	0	MIXINL_ENA	MIXINR_ENA	IN2L_ENA	IN1L_ENA	IN2R_ENA	IN1R_ENA	0	0	0	0	6000h
R3 (3h)	Power Management (3)	0	0	LINEOUT1N_ENA	LINEOUT1P_ENA	LINEOUT2N_ENA	LINEOUT2P_ENA	SPKRVOL_ENA	SPKLVOL_ENA	MIXOUTLV_ENA	MIXOUTRV_ENA	MIXOUTL_ENA	MIXOUTR_ENA	0	0	0	0	0000h
R4 (4h)	Power Management (4)	0	0	AIF2ADCL_ENA	AIF2ADCR_ENA	AIF1ADC2L_ENA	AIF1ADC2R_ENA	AIF1ADC1L_ENA	AIF1ADC1R_ENA	0	0	DMIC2L_ENA	DMIC2R_ENA	DMIC1L_ENA	DMIC1R_ENA	ADCL_ENA	ADCR_ENA	0000h
R5 (5h)	Power Management (5)	0	0	AIF2DACL_ENA	AIF2DACR_ENA	AIF1DAC2L_ENA	AIF1DAC2R_ENA	AIF1DAC1L_ENA	AIF1DAC1R_ENA	0	0	0	0	DAC2L_ENA	DAC2R_ENA	DAC1L_ENA	DAC1R_ENA	0000h
R6 (6h)	Power Management (6)	0	0	0	0	0	AIF3ADC_SRC [1:0]		AIF2DAC_SRC [1:0]		0	AIF3_TRI	AIF3_ADCDAT_SRC [1:0]		AIF2_ADCDAT_SR	AIF2_DACDAT_SR	AIF1_DACDAT_SR	0000h
R21 (15h)	Input Mixer (1)	0	0	0	0	0	0	0	IN1RPNR_BOOST	IN1LPNL_BOOST	INPUTS_CLAMP	0	0	0	0	0	0	0000h
R24 (18h)	Left Line Input 1&2 Volume	0	0	0	0	0	0	0	IN1_VU	IN1L_MUTE	IN1L_ZC	0	IN1L_VOL [4:0]				008Bh	
R25 (19h)	Left Line Input 3&4 Volume	0	0	0	0	0	0	0	IN2_VU	IN2L_MUTE	IN2L_ZC	0	IN2L_VOL [4:0]				008Bh	
R26 (1Ah)	Right Line Input 1&2 Volume	0	0	0	0	0	0	0	IN1_VU	IN1R_MUTE	IN1R_ZC	0	IN1R_VOL [4:0]				008Bh	
R27 (1Bh)	Right Line Input 3&4 Volume	0	0	0	0	0	0	0	IN2_VU	IN2R_MUTE	IN2R_ZC	0	IN2R_VOL [4:0]				008Bh	
R28 (1Ch)	Left Output Volume	0	0	0	0	0	0	0	HPOUT1_VU	HPOUT1L_ZC	HPOUT1L_MUTE_N	HPOUT1L_VOL [5:0]					006Dh	
R29 (1Dh)	Right Output Volume	0	0	0	0	0	0	0	HPOUT1_VU	HPOUT1R_ZC	HPOUT1R_MUTE_N	HPOUT1R_VOL [5:0]					006Dh	
R30 (1Eh)	Line Outputs Volume	0	0	0	0	0	0	0	0	0	LINEOUT1P_MUTE	LINEOUT1P_VOL	LINEOUT1V_MUTE	0	LINEOUT2N_MUTE	LINEOUT2P_MUTE	LINEOUT2V_MUTE	0066h
R31 (1Fh)	HPOUT2 Volume	0	0	0	0	0	0	0	0	0	0	HPOUT2_MUTE	HPOUT2_VOL	0	0	0	0	0020h
R32 (20h)	Left OPGA Volume	0	0	0	0	0	0	0	MIXOUT_VU	MIXOUTL_ZC	MIXOUTL_MUTE_N	MIXOUTL_VOL [5:0]					0079h	

REG	NAME	15	14	13	12	11	10	9	8	7	6	5	4	3	2	1	0	DEFAULT
R33 (21h)	Right OPGA Volume	0	0	0	0	0	0	0	MIXO UT_V U	MIXO UTR_Z C	MIXO UTR_MUTE_N	MIXOUTR_VOL [5:0]					0079h	
R34 (22h)	SPKMIXL Attenuation	0	0	0	0	0	0	0	SPKA B_REF_SEL	0	DAC2L_SPK MIXL_VOL	MIXIN L_SPK MIXL_VOL	IN1LP_SPK MIXL_VOL	MIXO UTL_SPK MIXL_VOL	DAC1L_SPK MIXL_VOL	SPKMIXL_VOL [1:0]		0003h
R35 (23h)	SPKMIXR Attenuation	0	0	0	0	0	0	0	SPKO UT_CL ASSA B	0	DAC2 R_SP KMIXR_VOL	MIXIN R_SP KMIXR_VOL	IN1RP_SPK MIXR_VOL	MIXO UTR_SPK MIXR_VOL	DAC1 R_SP KMIXR_VOL	SPKMIXR_VO L [1:0]		0003h
R36 (24h)	SPKOUT Mixers	0	0	0	0	0	0	0	0	0	0	IN2LR_P_TO_SPK UTL	SPKMI XL_TO_SPK OUTL	SPKMI XR_T O_SP KOUT L	IN2LR_P_TO_SPK UTR	SPKMI XL_TO_SPK OUTR	SPKMI XR_T O_SP KOUT R	0011h
R37 (25h)	ClassD	0	0	0	0	0	0	0	1	0	1	SPKOUTL_BOOST [2:0]			SPKOUTR_BOOST [2:0]		0140h	
R38 (26h)	Speaker Volume Left	0	0	0	0	0	0	0	SPKO UT_V U	SPKO UTL_Z C	SPKO UTL_MUTE_N	SPKOUTL_VOL [5:0]					0079h	
R39 (27h)	Speaker Volume Right	0	0	0	0	0	0	0	SPKO UT_V U	SPKO UTR_Z C	SPKO UTR_MUTE_N	SPKOUTR_VOL [5:0]					0079h	
R40 (28h)	Input Mixer (2)	0	0	0	0	0	0	0	0	IN2LP_TO_I N2L	IN2LN_TO_I N2L	IN1LP_TO_I N1L	IN1LN_TO_I N1L	IN2RP_TO_I N2R	IN2RN_TO_I N2R	IN1RP_TO_I N1R	IN1RN_TO_I N1R	0000h
R41 (29h)	Input Mixer (3)	0	0	0	0	0	0	0	IN2L_TO_MI XINL	IN2L_TO_MI XINL_VOL	0	IN1L_TO_MI XINL	IN1L_TO_MI XINL_VOL	0	MIXOUTL_MIXINL_VO L [2:0]			0000h
R42 (2Ah)	Input Mixer (4)	0	0	0	0	0	0	0	IN2R_TO_MI XINR	IN2R_TO_MI XINR_VOL	0	IN1R_TO_MI XINR	IN1R_TO_MI XINR_VOL	0	MIXOUTR_MIXINR_VO L [2:0]			0000h
R43 (2Bh)	Input Mixer (5)	0	0	0	0	0	0	0	IN1LP_MIXINL_VOL [2:0]		0	0	0	IN2LRP_MIXINL_VOL [2:0]			0000h	
R44 (2Ch)	Input Mixer (6)	0	0	0	0	0	0	0	IN1RP_MIXINR_VOL [2:0]		0	0	0	IN2LRP_MIXINR_VOL [2:0]			0000h	
R45 (2Dh)	Output Mixer (1)	0	0	0	0	0	0	0	DAC1L_TO_H POUT 1L	MIXIN R_TO_MIXO UTL	MIXIN L_TO_MIXO UTL	IN2RN_TO_MIXO UTL	IN2LN_TO_MIXO UTL	IN1R_TO_MI XOUT L	IN1L_TO_MI XOUT L	IN2LP_TO_MIXO UTL	DAC1L_TO_MIXO UTL	0000h
R46 (2Eh)	Output Mixer (2)	0	0	0	0	0	0	0	DAC1 R_TO_H POUT 1R	MIXIN L_TO_MIXO UTR	MIXIN R_TO_MIXO UTR	IN2LN_TO_MIXO UTR	IN2RN_TO_MIXO UTR	IN1L_TO_MI XOUT R	IN1R_TO_MI XOUT R	IN2RP_TO_MIXO UTR	DAC1 R_TO_MIXO UTR	0000h
R47 (2Fh)	Output Mixer (3)	0	0	0	0	IN2LP_MIXOUTL_VOL [2:0]			IN2LN_MIXOUTL_VOL [2:0]			IN1R_MIXOUTL_VOL [2:0]			IN1L_MIXOUTL_VOL [2:0]		0000h	
R48 (30h)	Output Mixer (4)	0	0	0	0	IN2RP_MIXOUTR_VOL [2:0]			IN2RN_MIXOUTR_VOL [2:0]			IN1L_MIXOUTR_VOL [2:0]			IN1R_MIXOUTR_VOL [2:0]		0000h	
R49 (31h)	Output Mixer (5)	0	0	0	0	DAC1L_MIXOUTL_VOL [2:0]			IN2RN_MIXOUTL_VOL [2:0]			MIXINR_MIXOUTL_VO L [2:0]			MIXINL_MIXOUTL_VO L [2:0]		0000h	
R50 (32h)	Output Mixer (6)	0	0	0	0	DAC1R_MIXOUTR_VO L [2:0]			IN2LN_MIXOUTR_VOL [2:0]			MIXINL_MIXOUTR_VO L [2:0]			MIXINR_MIXOUTR_VO L [2:0]		0000h	

REG	NAME	15	14	13	12	11	10	9	8	7	6	5	4	3	2	1	0	DEFAULT	
R51 (33h)	HPOUT2 Mixer	0	0	0	0	0	0	0	0	0	0	IN2LR P_TO_ HPOU T2	MIXO UTLV OL_T O_HP OUT2	MIXO UTRV OL_T O_HP OUT2	0	0	0	0000h	
R52 (34h)	Line Mixer (1)	0	0	0	0	0	0	0	0	0	MIXO UTL_T O_LIN EOUT 1N	MIXO UTR_T O_LIN EOUT 1N	LINEO UT1_ MODE	0	IN1R_ TO_LI NEOU T1P	IN1L_ TO_LI NEOU T1P	MIXO UTL_T O_LIN EOUT 1P	0000h	
R53 (35h)	Line Mixer (2)	0	0	0	0	0	0	0	0	0	MIXO UTR_T O_LIN EOUT 2N	MIXO UTL_T O_LIN EOUT 2N	LINEO UT2_ MODE	0	IN1L_ TO_LI NEOU T2P	IN1R_ TO_LI NEOU T2P	MIXO UTR_T O_LIN EOUT 2P	0000h	
R54 (36h)	Speaker Mixer	0	0	0	0	0	0	DAC2L _TO_S PKMIX L	DAC2 R_TO_ SPKMI XR	MIXIN L_TO_ SPKMI XL	MIXIN R_TO_ SPKMI XR	IN1LP _TO_S PKMIX L	IN1RP _TO_S PKMIX R	MIXO UTL_T O_SP KMIXL	MIXO UTR_T O_SP KMIXR	DAC1L _TO_S PKMIX L	DAC1 R_TO_ SPKMI XR	0000h	
R55 (37h)	Additional Control	0	0	0	0	0	0	0	0	LINEO UT1_F B	LINEO UT2_F B	0	0	0	0	0	0	VROI	0000h
R56 (38h)	AntiPOP (1)	0	0	0	0	0	0	0	0	LINEO UT_V MID_B UF_E NA	HPOU T2_IN _ENA	LINEO UT1_D ISCH	LINEO UT2_D ISCH	0	0	0	0	0	0000h
R57 (39h)	AntiPOP (2)	0	0	0	0	0	0	0	1	1	VMID_RAMP [1:0]	0	VMID_ BUF_E NA	STAR TUP_B IAS_E NA	BIAS_ SRC	VMID_ DISCH	0180h		
R59 (3Bh)	LDO 1	0	0	0	0	0	0	0	0	0	0	0	0	LDO1_VSEL [2:0]		LDO1_ DISCH	000Dh		
R60 (3Ch)	LDO 2	0	0	0	0	0	0	0	0	0	0	0	0	LDO2_VSEL [1:0]	LDO2_ DISCH	0005h			
R61 (3Dh)	MICBIAS1	0	0	0	0	0	0	0	0	0	0	MICB1 _RATE	MICB1 _MOD E	MICB1_LVL [2:0]		MICB1 _DISC H	0039h		
R62 (3Eh)	MICBIAS2	0	0	0	0	0	0	0	0	0	0	MICB2 _RATE	MICB2 _MOD E	MICB2_LVL [2:0]		MICB2 _DISC H	0039h		
R76 (4Ch)	Charge Pump (1)	CP_E NA	0	0	1	1	1	1	1	0	0	1	0	0	1	0	1	1F25h	
R77 (4Dh)	Charge Pump (2)	CP_DI SCH	0	1	0	1	0	1	1	0	0	0	1	1	0	0	1	AB19h	
R81 (51h)	Class W (1)	0	0	0	0	0	0	CP_DYN_SRC _SEL [1:0]		0	0	0	0	0	1	0	CP_D YN_P WR	0004h	
R84 (54h)	DC Servo (1)	0	0	DCS_ TRIG_ SINGL E_1	DCS_ TRIG_ SINGL E_0	0	0	DCS_ TRIG_ SERIE S_1	DCS_ TRIG_ SERIE S_0	0	0	DCS_ TRIG_ STAR TUP_1	DCS_ TRIG_ STAR TUP_0	DCS_ TRIG_ DAC_ WR_1	DCS_ TRIG_ DAC_ WR_0	DCS_ ENA_ CHAN _1	DCS_ ENA_ CHAN _0	0000h	
R85 (55h)	DC Servo (2)	0	0	0	0	DCS_SERIES_NO_01 [6:0]						0	DCS_TIMER_PERIOD_01 [3:0]			054Ah			
R87 (57h)	DC Servo (4)	DCS_DAC_WR_VAL_1 [7:0]						DCS_DAC_WR_VAL_0 [7:0]									0000h		
R88 (58h)	DC Servo Readback	0	0	0	0	0	0	DCS_CAL_CO MPLETE [1:0]		0	0	DCS_DAC_WR _COMPLETE [1:0]		0	0	DCS_STARTU P_COMPLETE [1:0]		0000h	
R96 (60h)	Analogue HP (1)	0	0	0	0	0	0	0	0	HPOU T1L_R MV_S HORT	HPOU T1L_O UTP	HPOU T1L_D LY	0	HPOU T1R_R MV_S HORT	HPOU T1R_O UTP	HPOU T1R_D LY	0	0000h	

REG	NAME	15	14	13	12	11	10	9	8	7	6	5	4	3	2	1	0	DEFAULT
R208 (D0h)	Mic Detect 1	MICD_BIAS_STARTTIME [3:0]				MICD_RATE [3:0]				0	0	0	0	0	0	MICD_DBTIME	MICD_ENA	5600h
R209 (D1h)	Mic Detect 2	0	0	0	0	0	0	0	0	MICD_LVL_SEL [7:0]							007Fh	
R210 (D2h)	Mic Detect 3	0	0	0	0	0	MICD_LVL [8:0]							MICD_VALID	MICD_STS	0000h		
R256 (100h)	Chip Revision	0	0	0	0	0	0	0	0	0	0	0	0	CHIP_REV [3:0]			000Xh	
R257 (101h)	Control Interface	1	0	0	0	0	0	0	0	0	0	0	0	AUTO_INC	0	0	8004h	
R272 (110h)	Write Sequencer Ctrl (1)	WSEQ_ENA	0	0	0	0	0	WSEQ_ABORT	WSEQ_START	0	WSEQ_START_INDEX [6:0]						0000h	
R273 (111h)	Write Sequencer Ctrl (2)	0	0	0	0	0	0	0	WSEQ_BUSY	0	WSEQ_CURRENT_INDEX [6:0]						0000h	
R512 (200h)	AIF1 Clocking (1)	0	0	0	0	0	0	0	0	0	0	AIF1CLK_SRC [1:0]	AIF1CLK_INV	AIF1CLK_DI	AIF1CLK_ENA	0000h		
R513 (201h)	AIF1 Clocking (2)	0	0	0	0	0	0	0	0	0	AIF1DAC_DIV [2:0]	AIF1ADC_DIV [2:0]			0000h			
R516 (204h)	AIF2 Clocking (1)	0	0	0	0	0	0	0	0	0	0	AIF2CLK_SRC [1:0]	AIF2CLK_INV	AIF2CLK_DI	AIF2CLK_ENA	0000h		
R517 (205h)	AIF2 Clocking (2)	0	0	0	0	0	0	0	0	0	AIF2DAC_DIV [2:0]	AIF2ADC_DIV [2:0]			0000h			
R520 (208h)	Clocking (1)	0	DSP2_CLK_ENA	0	0	0	0	0	0	0	0	TOCLK_ENA	AIF1D_SPCLK_ENA	AIF2D_SPCLK_ENA	SYSD_SPCLK_ENA	SYSC_LK_SRC	0000h	
R521 (209h)	Clocking (2)	0	0	0	0	0	TOCLK_DIV [2:0]		0	DBCLK_DIV [2:0]		0	OPCLK_DIV [2:0]		0000h			
R528 (210h)	AIF1 Rate	0	0	0	0	0	0	0	AIF1_SR [3:0]			AIF1CLK_RATE [3:0]			0083h			
R529 (211h)	AIF2 Rate	0	0	0	0	0	0	0	AIF2_SR [3:0]			AIF2CLK_RATE [3:0]			0083h			
R530 (212h)	Rate Status	0	0	0	0	0	0	0	0	0	0	SR_ERROR [3:0]			0000h			
R544 (220h)	FLL1 Control (1)	0	0	0	0	0	0	0	0	0	0	0	0	FLL1_OSC_ENA	FLL1_ENA	0000h		
R545 (221h)	FLL1 Control (2)	0	0	FLL1_OUTDIV [5:0]						0	0	0	0	FLL1_FRATIO [2:0]		0000h		
R546 (222h)	FLL1 Control (3)	FLL1_THETA [15:0]															0000h	
R547 (223h)	FLL1 Control (4)	0	FLL1_N [9:0]									0	0	0	0	0	0000h	
R548 (224h)	FLL1 Control (5)	FLL1_BYP	0	0	FLL1_FRC_NCO_VAL [5:0]					FLL1_FRC_NCO	0	FLL1_REFCLK_DIV [1:0]		FLL1_REFCLK_SRC [1:0]		0C80h		
R550 (226h)	FLL1 EFS1	FLL2_LAMBDA [15:0]															0000h	
R551 (227h)	FLL1 EFS2	0	0	0	0	0	0	0	0	0	0	0	0	1	1	FLL1_EFS_ENA	0006h	
R576 (240h)	FLL2 Control (1)	0	0	0	0	0	0	0	0	0	0	0	0	0	FLL2_OSC_ENA	FLL2_ENA	0000h	
R577 (241h)	FLL2 Control (2)	0	0	FLL2_OUTDIV [5:0]						0	0	0	0	FLL2_FRATIO [2:0]		0000h		
R578 (242h)	FLL2 Control (3)	FLL2_THETA [15:0]															0000h	
R579 (243h)	FLL2 Control (4)	0	FLL2_N [9:0]									0	0	0	0	0	0000h	
R580 (244h)	FLL2 Control (5)	FLL2_BYP	0	0	FLL2_FRC_NCO_VAL [5:0]					FLL2_FRC_NCO	0	FLL2_REFCLK_DIV [1:0]		FLL2_REFCLK_SRC [1:0]		0C80h		
R582 (246h)	FLL2 EFS1	FLL2_LAMBDA [15:0]															0000h	
R583 (247h)	FLL2 EFS2	0	0	0	0	0	0	0	0	0	0	0	0	1	1	FLL2_EFS_ENA	0006h	

REG	NAME	15	14	13	12	11	10	9	8	7	6	5	4	3	2	1	0	DEFAULT
R768 (300h)	AIF1 Control (1)	AIF1A DCL_S RC	AIF1A DCR_ SRC	AIF1A DC_T DM	0	0	0	0	AIF1_ BCLK_ INV	0	AIF1_WL [1:0]		AIF1_FMT [1:0]		0	0	0	4050h
R769 (301h)	AIF1 Control (2)	AIF1D ACL_S RC	AIF1D ACR_ SRC	0	0	AIF1DAC_BOO ST [1:0]		0	AIF1_ MONO	0	0	0	AIF1D AC_C OMP	AIF1D AC_C OMPM ODE	AIF1A DC_C OMP	AIF1A DC_C OMPM ODE	AIF1_L OOPB ACK	4000h
R770 (302h)	AIF1 Master/Slave	AIF1_ TRI	AIF1_ MSTR	AIF1_ CLK_F RC	AIF1_L RCLK_ FRC	0	0	0	0	0	0	0	0	0	0	0	0	0000h
R771 (303h)	AIF1 BCLK	0	0	0	0	0	0	0	AIF1_BCLK_DIV [4:0]				0	0	0	0	0040h	
R772 (304h)	AIF1ADC LRCLK	0	0	0	AIF1A DC_LR CLK_I NV	AIF1A DC_LR CLK_D IR	AIF1ADC_RATE [10:0]											0040h
R773 (305h)	AIF1DAC LRCLK	0	0	0	AIF1D AC_LR CLK_I NV	AIF1D AC_LR CLK_D IR	AIF1DAC_RATE [10:0]											0040h
R774 (306h)	AIF1DAC Data	0	0	0	0	0	0	0	0	0	0	0	0	0	0	AIF1D ACL_D AT_IN V	AIF1D ACR_ DAT_I NV	0000h
R775 (307h)	AIF1ADC Data	0	0	0	0	0	0	0	0	0	0	0	0	0	0	AIF1A DCL_D AT_IN V	AIF1A DCR_ DAT_I NV	0000h
R784 (310h)	AIF2 Control (1)	AIF2A DCL_S RC	AIF2A DCR_ SRC	AIF2A DC_T DM	AIF2A DC_T DM_C HAN	0	0	0	AIF2_ BCLK_ INV	0	AIF2_WL [1:0]		AIF2_FMT [1:0]		0	AIF2T XL_EN A	AIF2T XR_E NA	4053h
R785 (311h)	AIF2 Control (2)	AIF2D ACL_S RC	AIF2D ACR_ SRC	AIF2D AC_T DM	AIF2D AC_T DM_C HAN	AIF2DAC_BOO ST [1:0]		0	AIF2_ MONO	0	0	0	AIF2D AC_C OMP	AIF2D AC_C OMPM ODE	AIF2A DC_C OMP	AIF2A DC_C OMPM ODE	AIF2_L OOPB ACK	4000h
R786 (312h)	AIF2 Master/Slave	AIF2_ TRI	AIF2_ MSTR	AIF2_ CLK_F RC	AIF2_L RCLK_ FRC	0	0	0	0	0	0	0	0	0	0	0	0	0000h
R787 (313h)	AIF2 BCLK	0	0	0	0	0	0	0	AIF2_BCLK_DIV [4:0]				0	0	0	0	0040h	
R788 (314h)	AIF2ADC LRCLK	0	0	0	AIF2A DC_LR CLK_I NV	AIF2A DC_LR CLK_D IR	AIF2ADC_RATE [10:0]											0040h
R789 (315h)	AIF2DAC LRCLK	0	0	0	AIF2D AC_LR CLK_I NV	AIF2D AC_LR CLK_D IR	AIF2DAC_RATE [10:0]											0040h
R790 (316h)	AIF2DAC Data	0	0	0	0	0	0	0	0	0	0	0	0	0	0	AIF2D ACL_D AT_IN V	AIF2D ACR_ DAT_I NV	0000h
R791 (317h)	AIF2ADC Data	0	0	0	0	0	0	0	0	0	0	0	0	0	0	AIF2A DCL_D AT_IN V	AIF2A DCR_ DAT_I NV	0000h
R800 (320h)	AIF3 Control (1)	0	0	0	0	0	0	0	0	AIF3_L RCLK_ INV	AIF3_WL [1:0]		0	0	0	0	0	0040h

REG	NAME	15	14	13	12	11	10	9	8	7	6	5	4	3	2	1	0	DEFAULT	
R801 (321h)	AIF3 Control (2)	0	0	0	0	AIF3DAC_BOOST [1:0]		0	0	0	0	0	AIF3D AC_C OMP	AIF3D AC_C OMPM ODE	AIF3A DC_C OMP	AIF3A DC_C OMPM ODE	AIF3_L OOPB ACK	0000h	
R802 (322h)	AIF3DAC Data	0	0	0	0	0	0	0	0	0	0	0	0	0	0	0	AIF3D AC_D AT_IN V	0000h	
R803 (323h)	AIF3ADC Data	0	0	0	0	0	0	0	0	0	0	0	0	0	0	0	AIF3A DC_D AT_IN V	0000h	
R1024 (400h)	AIF1 ADC1 Left Volume	0	0	0	0	0	0	0	AIF1A DC1_V U	AIF1ADC1L_VOL [7:0]							00C0h		
R1025 (401h)	AIF1 ADC1 Right Volume	0	0	0	0	0	0	0	AIF1A DC1_V U	AIF1ADC1R_VOL [7:0]							00C0h		
R1026 (402h)	AIF1 DAC1 Left Volume	0	0	0	0	0	0	0	AIF1D AC1_V U	AIF1DAC1L_VOL [7:0]							00C0h		
R1027 (403h)	AIF1 DAC1 Right Volume	0	0	0	0	0	0	0	AIF1D AC1_V U	AIF1DAC1R_VOL [7:0]							00C0h		
R1028 (404h)	AIF1 ADC2 Left Volume	0	0	0	0	0	0	0	AIF1A DC2_V U	AIF1ADC2L_VOL [7:0]							00C0h		
R1029 (405h)	AIF1 ADC2 Right Volume	0	0	0	0	0	0	0	AIF1A DC2_V U	AIF1ADC2R_VOL [7:0]							00C0h		
R1030 (406h)	AIF1 DAC2 Left Volume	0	0	0	0	0	0	0	AIF1D AC2_V U	AIF1DAC2L_VOL [7:0]							00C0h		
R1031 (407h)	AIF1 DAC2 Right Volume	0	0	0	0	0	0	0	AIF1D AC2_V U	AIF1DAC2R_VOL [7:0]							00C0h		
R1040 (410h)	AIF1 ADC1 Filters	AIF1A DC_4F S	AIF1ADC1_HP F_CUT [1:0]		AIF1A DC1L_ HPF	AIF1A DC1R_ HPF	0	0	0	0	0	0	0	0	0	0	0	0000h	
R1041 (411h)	AIF1 ADC2 Filters	0	AIF1ADC2_HP F_CUT [1:0]		AIF1A DC2L_ HPF	AIF1A DC2R_ HPF	0	0	0	0	0	0	0	0	0	0	0	0000h	
R1056 (420h)	AIF1 DAC1 Filters (1)	0	0	0	0	0	0	AIF1D AC1_ MUTE	0	AIF1D AC1_ MONO	0	AIF1D AC1_ MUTE RATE	AIF1D AC1_U NMUT E_RA MP	0	0	0	0	0200h	
R1057 (421h)	AIF1 DAC1 Filters (2)	0	0	AIF1DAC1_3D_GAIN [4:0]				AIF1D AC1_3 D_EN A	0	0	0	0	1	0	0	0	0	0	0010h
R1058 (422h)	AIF1 DAC2 Filters (1)	0	0	0	0	0	0	AIF1D AC2_ MUTE	0	AIF1D AC2_ MONO	0	AIF1D AC2_ MUTE RATE	AIF1D AC2_U NMUT E_RA MP	0	0	0	0	0200h	
R1059 (423h)	AIF1 DAC2 Filters (2)	0	0	AIF1DAC2_3D_GAIN [4:0]				AIF1D AC2_3 D_EN A	0	0	0	0	1	0	0	0	0	0	0010h

REG	NAME	15	14	13	12	11	10	9	8	7	6	5	4	3	2	1	0	DEFAULT
R1072 (430h)	AIF1 DAC1 Noise Gate	0	0	0	0	0	0	0	0	0	AIF1DAC1_NG_HLD [1:0]		0	AIF1DAC1_NG_THR [2:0]		AIF1D AC1_N G_EN A		0068h
R1073 (431h)	AIF1 DAC2 Noise Gate	0	0	0	0	0	0	0	0	0	AIF1DAC2_NG_HLD [1:0]		0	AIF1DAC2_NG_THR [2:0]		AIF1D AC2_N G_EN A		0068h
R1088 (440h)	AIF1 DRC1 (1)	AIF1DRC1_SIG_DET_RMS [4:0]				AIF1DRC1_SIG_DET_PK [1:0]			AIF1D RC1_N G_EN A	AIF1D RC1_S IG_DE T_MO DE	AIF1D RC1_S IG_DE T	AIF1D RC1_K NEE2_ OP_E NA	AIF1D RC1_QR	AIF1D RC1_A NTICLI P	AIF1D AC1_D RC_E NA	AIF1A DC1L_ DRC_ ENA	AIF1A DC1R_ DRC_ ENA	0098h
R1089 (441h)	AIF1 DRC1 (2)	0	0	0	AIF1DRC1_ATK [3:0]			AIF1DRC1_DCY [3:0]			AIF1DRC1_MINGAIN [2:0]		AIF1DRC1_MAXGAIN [1:0]		0845h			
R1090 (442h)	AIF1 DRC1 (3)	AIF1DRC1_NG_MINGAIN [3:0]			AIF1DRC1_NG_EXP [1:0]		AIF1DRC1_QR_THR [1:0]	AIF1DRC1_QR_DCY [1:0]	AIF1DRC1_HI_COMP [2:0]		AIF1DRC1_LO_COMP [2:0]		0000h					
R1091 (443h)	AIF1 DRC1 (4)	0	0	0	0	0	AIF1DRC1_KNEE_IP [5:0]				AIF1DRC1_KNEE_OP [4:0]				0000h			
R1092 (444h)	AIF1 DRC1 (5)	0	0	0	0	0	AIF1DRC1_KNEE2_IP [4:0]				AIF1DRC1_KNEE2_OP [4:0]				0000h			
R1104 (450h)	AIF1 DRC2 (1)	AIF1DRC2_SIG_DET_RMS [4:0]				AIF1DRC2_SIG_DET_PK [1:0]			AIF1D RC2_N G_EN A	AIF1D RC2_S IG_DE T_MO DE	AIF1D RC2_S IG_DE T	AIF1D RC2_K NEE2_ OP_E NA	AIF1D RC2_QR	AIF1D RC2_A NTICLI P	AIF1D AC2_D RC_E NA	AIF1A DC2L_ DRC_ ENA	AIF1A DC2R_ DRC_ ENA	0098h
R1105 (451h)	AIF1 DRC2 (2)	0	0	0	AIF1DRC2_ATK [3:0]			AIF1DRC2_DCY [3:0]			AIF1DRC2_MINGAIN [2:0]		AIF1DRC2_MAXGAIN [1:0]		0845h			
R1106 (452h)	AIF1 DRC2 (3)	AIF1DRC2_NG_MINGAIN [3:0]			AIF1DRC2_NG_EXP [1:0]		AIF1DRC2_QR_THR [1:0]	AIF1DRC2_QR_DCY [1:0]	AIF1DRC2_HI_COMP [2:0]		AIF1DRC2_LO_COMP [2:0]		0000h					
R1107 (453h)	AIF1 DRC2 (4)	0	0	0	0	0	AIF1DRC2_KNEE_IP [5:0]				AIF1DRC2_KNEE_OP [4:0]				0000h			
R1108 (454h)	AIF1 DRC2 (5)	0	0	0	0	0	AIF1DRC2_KNEE2_IP [4:0]				AIF1DRC2_KNEE2_OP [4:0]				0000h			
R1152 (480h)	AIF1 DAC1 EQ Gains (1)	AIF1DAC1_EQ_B1_GAIN [4:0]				AIF1DAC1_EQ_B2_GAIN [4:0]				AIF1DAC1_EQ_B3_GAIN [4:0]				AIF1D AC1_E Q_EN A		6318h		
R1153 (481h)	AIF1 DAC1 EQ Gains (2)	AIF1DAC1_EQ_B4_GAIN [4:0]				AIF1DAC1_EQ_B5_GAIN [4:0]				0	0	0	0	0	AIF1D AC1_E Q_MO DE		6300h	
R1154 (482h)	AIF1 DAC1 EQ Band 1 A	AIF1DAC1_EQ_B1_A [15:0]																0FCAh
R1155 (483h)	AIF1 DAC1 EQ Band 1 B	AIF1DAC1_EQ_B1_B [15:0]																0400h
R1156 (484h)	AIF1 DAC1 EQ Band 1 PG	AIF1DAC1_EQ_B1_PG [15:0]																00D8h
R1157 (485h)	AIF1 DAC1 EQ Band 2 A	AIF1DAC1_EQ_B2_A [15:0]																1EB5h
R1158 (486h)	AIF1 DAC1 EQ Band 2 B	AIF1DAC1_EQ_B2_B [15:0]																F145h
R1159 (487h)	AIF1 DAC1 EQ Band 2 C	AIF1DAC1_EQ_B2_C [15:0]																0B75h
R1160 (488h)	AIF1 DAC1 EQ Band 2 PG	AIF1DAC1_EQ_B2_PG [15:0]																01C5h
R1161 (489h)	AIF1 DAC1 EQ Band 3 A	AIF1DAC1_EQ_B3_A [15:0]																1C58h
R1162 (48Ah)	AIF1 DAC1 EQ Band 3 B	AIF1DAC1_EQ_B3_B [15:0]																F373h
R1163 (48Bh)	AIF1 DAC1 EQ Band 3 C	AIF1DAC1_EQ_B3_C [15:0]																0A54h
R1164 (48Ch)	AIF1 DAC1 EQ Band 3 PG	AIF1DAC1_EQ_B3_PG [15:0]																0558h

REG	NAME	15	14	13	12	11	10	9	8	7	6	5	4	3	2	1	0	DEFAULT	
R1165 (48Dh)	AIF1 DAC1 EQ Band 4 A	AIF1DAC1_EQ_B4_A [15:0]																168Eh	
R1166 (48Eh)	AIF1 DAC1 EQ Band 4 B	AIF1DAC1_EQ_B4_B [15:0]																F829h	
R1167 (48Fh)	AIF1 DAC1 EQ Band 4 C	AIF1DAC1_EQ_B4_C [15:0]																07ADh	
R1168 (490h)	AIF1 DAC1 EQ Band 4 PG	AIF1DAC1_EQ_B4_PG [15:0]																1103h	
R1169 (491h)	AIF1 DAC1 EQ Band 5 A	AIF1DAC1_EQ_B5_A [15:0]																0564h	
R1170 (492h)	AIF1 DAC1 EQ Band 5 B	AIF1DAC1_EQ_B5_B [15:0]																0559h	
R1171 (493h)	AIF1 DAC1 EQ Band 5 PG	AIF1DAC1_EQ_B5_PG [15:0]																4000h	
R1172 (494h)	AIF1 DAC1 EQ Band 1 C	AIF1DAC1_EQ_B1_C [15:0]																0000h	
R1184 (4A0h)	AIF1 DAC2 EQ Gains (1)	AIF1DAC2_EQ_B1_GAIN [4:0]				AIF1DAC2_EQ_B2_GAIN [4:0]				AIF1DAC2_EQ_B3_GAIN [4:0]				AIF1D AC2_E Q_EN A				6318h	
R1185 (4A1h)	AIF1 DAC2 EQ Gains (2)	AIF1DAC2_EQ_B4_GAIN [4:0]				AIF1DAC2_EQ_B5_GAIN [4:0]				0	0	0	0	0	AIF1D AC2_E Q_MO DE				6300h
R1186 (4A2h)	AIF1 DAC2 EQ Band 1 A	AIF1DAC2_EQ_B1_A [15:0]																0FCAh	
R1187 (4A3h)	AIF1 DAC2 EQ Band 1 B	AIF1DAC2_EQ_B1_B [15:0]																0400h	
R1188 (4A4h)	AIF1 DAC2 EQ Band 1 PG	AIF1DAC2_EQ_B1_PG [15:0]																00D8h	
R1189 (4A5h)	AIF1 DAC2 EQ Band 2 A	AIF1DAC2_EQ_B2_A [15:0]																1EB5h	
R1190 (4A6h)	AIF1 DAC2 EQ Band 2 B	AIF1DAC2_EQ_B2_B [15:0]																F145h	
R1191 (4A7h)	AIF1 DAC2 EQ Band 2 C	AIF1DAC2_EQ_B2_C [15:0]																0B75h	
R1192 (4A8h)	AIF1 DAC2 EQ Band 2 PG	AIF1DAC2_EQ_B2_PG [15:0]																01C5h	
R1193 (4A9h)	AIF1 DAC2 EQ Band 3 A	AIF1DAC2_EQ_B3_A [15:0]																1C58h	
R1194 (4AAh)	AIF1 DAC2 EQ Band 3 B	AIF1DAC2_EQ_B3_B [15:0]																F373h	
R1195 (4ABh)	AIF1 DAC2 EQ Band 3 C	AIF1DAC2_EQ_B3_C [15:0]																0A54h	
R1196 (4ACh)	AIF1 DAC2 EQ Band 3 PG	AIF1DAC2_EQ_B3_PG [15:0]																0558h	
R1197 (4ADh)	AIF1 DAC2 EQ Band 4 A	AIF1DAC2_EQ_B4_A [15:0]																168Eh	
R1198 (4AEh)	AIF1 DAC2 EQ Band 4 B	AIF1DAC2_EQ_B4_B [15:0]																F829h	
R1199 (4AFh)	AIF1 DAC2 EQ Band 4 C	AIF1DAC2_EQ_B4_C [15:0]																07ADh	
R1200 (4B0h)	AIF1 DAC2 EQ Band 4 PG	AIF1DAC2_EQ_B4_PG [15:0]																1103h	
R1201 (4B1h)	AIF1 DAC2 EQ Band 5 A	AIF1DAC2_EQ_B5_A [15:0]																0564h	
R1202 (4B2h)	AIF1 DAC2 EQ Band 5 B	AIF1DAC2_EQ_B5_B [15:0]																0559h	

REG	NAME	15	14	13	12	11	10	9	8	7	6	5	4	3	2	1	0	DEFAULT		
R1203 (4B3h)	AIF1 DAC2 EQ Band 5 PG	AIF1DAC2_EQ_B5_PG [15:0]																4000h		
R1204 (4B4h)	AIF1 DAC2 EQ Band 1 C	AIF1DAC2_EQ_B1_C [15:0]																0000h		
R1280 (500h)	AIF2 ADC Left Volume	0	0	0	0	0	0	0	AIF2A DC_V U	AIF2ADCL_VOL [7:0]							00C0h			
R1281 (501h)	AIF2 ADC Right Volume	0	0	0	0	0	0	0	AIF2A DC_V U	AIF2ADCR_VOL [7:0]							00C0h			
R1282 (502h)	AIF2 DAC Left Volume	0	0	0	0	0	0	0	AIF2D AC_V U	AIF2DACL_VOL [7:0]							00C0h			
R1283 (503h)	AIF2 DAC Right Volume	0	0	0	0	0	0	0	AIF2D AC_V U	AIF2DACR_VOL [7:0]							00C0h			
R1296 (510h)	AIF2 ADC Filters	0	AIF2ADC_HPF_CUT [1:0]		AIF2A DCL_H PF	AIF2A DCR_H PF	0	0	0	0	0	0	0	0	0	0	0	0000h		
R1312 (520h)	AIF2 DAC Filters (1)	0	0	0	0	0	0	AIF2D AC_M UTE	0	AIF2D AC_M ONO	0	AIF2D AC_M UTER ATE	AIF2D AC_U NMUT E_RA MP	0	0	0	0	0200h		
R1313 (521h)	AIF2 DAC Filters (2)	0	0	AIF2DAC_3D_GAIN [4:0]				AIF2D AC_3D _ENA	0	0	0	0	1	0	0	0	0	0	0010h	
R1328 (531h)	AIF2 DAC Noise Gate	0	0	0	0	0	0	0	0	0	AIF2DAC_NG_HLD [1:0]	0	AIF2DAC_NG_THR [2:0]		AIF2D AC_N G_EN A	0	0068h			
R1344 (540h)	AIF2 DRC (1)	AIF2DRC_SIG_DET_RMS [4:0]				AIF2DRC_SIG_DET_PK [1:0]			AIF2D RC_N G_EN A	AIF2D RC_SI G_DE T_MO DE	AIF2D RC_SI G_DE T	AIF2D RC_K NEE2_OP_E NA	AIF2D RC_Q R	AIF2D RC_A NTICLI P	AIF2D AC_D RC_E NA	AIF2A DCL_D RC_E NA	AIF2A DCR_DRC_ENA	0	0098h	
R1345 (541h)	AIF2 DRC (2)	0	0	0	AIF2DRC_ATK [3:0]			AIF2DRC_DCY [3:0]			AIF2DRC_MINGAIN [2:0]		AIF2DRC_MAXGAIN [1:0]		0	0	0	0	0	0845h
R1346 (542h)	AIF2 DRC (3)	AIF2DRC_NG_MINGAIN [3:0]			AIF2DRC_NG_EXP [1:0]		AIF2DRC_QR_THR [1:0]	AIF2DRC_QR_DCY [1:0]	AIF2DRC_HI_COMP [2:0]		AIF2DRC_LO_COMP [2:0]		0	0	0	0	0	0	0	0000h
R1347 (543h)	AIF2 DRC (4)	0	0	0	0	0	AIF2DRC_KNEE_IP [5:0]				AIF2DRC_KNEE_OP [4:0]				0	0	0	0	0	0000h
R1348 (544h)	AIF2 DRC (5)	0	0	0	0	0	AIF2DRC_KNEE2_IP [4:0]				AIF2DRC_KNEE2_OP [4:0]				0	0	0	0	0	0000h
R1408 (580h)	AIF2 EQ Gains (1)	AIF2DAC_EQ_B1_GAIN [4:0]				AIF2DAC_EQ_B2_GAIN [4:0]				AIF2DAC_EQ_B3_GAIN [4:0]				AIF2D AC_E Q_EN A	0	0	0	0	0	6318h
R1409 (581h)	AIF2 EQ Gains (2)	AIF2DAC_EQ_B4_GAIN [4:0]				AIF2DAC_EQ_B5_GAIN [4:0]				0	0	0	0	0	AIF2D AC_E Q_MO DE	0	0	0	0	6300h
R1410 (582h)	AIF2 EQ Band 1 A	AIF2DAC_EQ_B1_A [15:0]																0FCAh		
R1411 (583h)	AIF2 EQ Band 1 B	AIF2DAC_EQ_B1_B [15:0]																0400h		
R1412 (584h)	AIF2 EQ Band 1 PG	AIF2DAC_EQ_B1_PG [15:0]																00D8h		
R1413 (585h)	AIF2 EQ Band 2 A	AIF2DAC_EQ_B2_A [15:0]																1EB5h		
R1414 (586h)	AIF2 EQ Band 2 B	AIF2DAC_EQ_B2_B [15:0]																F145h		
R1415 (587h)	AIF2 EQ Band 2 C	AIF2DAC_EQ_B2_C [15:0]																0B75h		
R1416 (588h)	AIF2 EQ Band 2 PG	AIF2DAC_EQ_B2_PG [15:0]																01C5h		
R1417 (589h)	AIF2 EQ Band 3 A	AIF2DAC_EQ_B3_A [15:0]																1C58h		

REG	NAME	15	14	13	12	11	10	9	8	7	6	5	4	3	2	1	0	DEFAULT
R1418 (58Ah)	AIF2 EQ Band 3 B	AIF2DAC_EQ_B3_B [15:0]																F373h
R1419 (58Bh)	AIF2 EQ Band 3 C	AIF2DAC_EQ_B3_C [15:0]																0A54h
R1420 (58Ch)	AIF2 EQ Band 3 PG	AIF2DAC_EQ_B3_PG [15:0]																0558h
R1421 (58Dh)	AIF2 EQ Band 4 A	AIF2DAC_EQ_B4_A [15:0]																168Eh
R1422 (58Eh)	AIF2 EQ Band 4 B	AIF2DAC_EQ_B4_B [15:0]																F829h
R1423 (58Fh)	AIF2 EQ Band 4 C	AIF2DAC_EQ_B4_C [15:0]																07ADh
R1424 (590h)	AIF2 EQ Band 4 PG	AIF2DAC_EQ_B4_PG [15:0]																1103h
R1425 (591h)	AIF2 EQ Band 5 A	AIF2DAC_EQ_B5_A [15:0]																0564h
R1426 (592h)	AIF2 EQ Band 5 B	AIF2DAC_EQ_B5_B [15:0]																0559h
R1427 (593h)	AIF2 EQ Band 5 PG	AIF2DAC_EQ_B5_PG [15:0]																4000h
R1428 (594h)	AIF2 EQ Band 1 C	AIF2DAC_EQ_B1_C [15:0]																0000h
R1536 (600h)	DAC1 Mixer Volumes	0	0	0	0	0	0	0	ADCR_DAC1_VOL [3:0]			0	ADCL_DAC1_VOL [3:0]			0000h		
R1537 (601h)	DAC1 Left Mixer Routing	0	0	0	0	0	0	0	0	0	0	ADCR_TO_D AC1L	ADCL_TO_D AC1L	0	AIF2D ACL_T O_DA C1L	AIF1D AC2L TO_D AC1L	AIF1D AC1L TO_D AC1L	0000h
R1538 (602h)	DAC1 Right Mixer Routing	0	0	0	0	0	0	0	0	0	0	ADCR_TO_D AC1R	ADCL_TO_D AC1R	0	AIF2D ACR_ TO_D AC1R	AIF1D AC2R_ TO_D AC1R	AIF1D AC1R_ TO_D AC1R	0000h
R1539 (603h)	DAC2 Mixer Volumes	0	0	0	0	0	0	0	ADCR_DAC2_VOL [3:0]			0	ADCL_DAC2_VOL [3:0]			0000h		
R1540 (604h)	DAC2 Left Mixer Routing	0	0	0	0	0	0	0	0	0	0	ADCR_TO_D AC2L	ADCL_TO_D AC2L	0	AIF2D ACL_T O_DA C2L	AIF1D AC2L TO_D AC2L	AIF1D AC1L_ TO_D AC2L	0000h
R1541 (605h)	DAC2 Right Mixer Routing	0	0	0	0	0	0	0	0	0	0	ADCR_TO_D AC2R	ADCL_TO_D AC2R	0	AIF2D ACR_ TO_D AC2R	AIF1D AC2R_ TO_D AC2R	AIF1D AC1R_ TO_D AC2R	0000h
R1542 (606h)	AIF1 ADC1 Left Mixer Routing	0	0	0	0	0	0	0	0	0	0	0	0	0	0	ADC1L _TO_A IF1AD C1L	AIF2D ACL_T O_AIF 1ADC1 L	0000h
R1543 (607h)	AIF1 ADC1 Right Mixer Routing	0	0	0	0	0	0	0	0	0	0	0	0	0	0	ADC1 R_TO_ AIF1A DC1R	AIF2D ACR_ TO_AI F1AD C1R	0000h
R1544 (608h)	AIF1 ADC2 Left Mixer Routing	0	0	0	0	0	0	0	0	0	0	0	0	0	0	ADC2L _TO_A IF1AD C2L	AIF2D ACL_T O_AIF 1ADC2 L	0000h
R1545 (609h)	AIF1 ADC2 Right mixer Routing	0	0	0	0	0	0	0	0	0	0	0	0	0	0	ADC2 R_TO_ AIF1A DC2R	AIF2D ACR_ TO_AI F1AD C2R	0000h
R1552 (610h)	DAC1 Left Volume	0	0	0	0	0	0	DAC1L _MUT E	DAC1_ VU	DAC1L_VOL [7:0]							02C0h	
R1553 (611h)	DAC1 Right Volume	0	0	0	0	0	0	DAC1 R_MU TE	DAC1_ VU	DAC1R_VOL [7:0]							02C0h	

REG	NAME	15	14	13	12	11	10	9	8	7	6	5	4	3	2	1	0	DEFAULT	
R1554 (612h)	DAC2 Left Volume	0	0	0	0	0	0	DAC2L_MUTE	DAC2_VU	DAC2L_VOL [7:0]							02C0h		
R1555 (613h)	DAC2 Right Volume	0	0	0	0	0	0	DAC2R_MUTE	DAC2_VU	DAC2R_VOL [7:0]							02C0h		
R1556 (614h)	DAC Softmute	0	0	0	0	0	0	0	0	0	0	0	0	0	0	DAC_SOFTMUTE_MODE	DAC_MUTE_RATE	0000h	
R1568 (620h)	Oversampling	0	0	0	0	0	0	0	0	0	0	0	0	0	0	ADC_OSR1_28	DAC_OSR1_28	0002h	
R1569 (621h)	Sidetone	0	0	0	0	0	0	ST_HPF_CUT [2:0]		ST_HPF	0	0	0	0	STR_STEL	STL_STEL	0000h		
R1792 (700h)	GPIO 1	GP1_DIR	GP1_PU	GP1_PD	0	0	GP1_POL	GP1_OP_CFG	GP1_DB	0	GP1_LVL	0	GP1_FN [4:0]				8100h		
R1793 (701h)	Pull Control (MCLK2)	1	MCLK2_PU	MCLK2_PD	0	0	0	0	1	0	0	0	0	0	0	0	1	A101h	
R1794 (702h)	Pull Control (BCLK2)	1	BCLK2_PU	BCLK2_PD	0	0	0	0	1	0	0	0	0	0	0	0	1	A101h	
R1795 (703h)	Pull Control (DACLRCLK2)	1	DACL_RCLK2_PU	DACL_RCLK2_PD	0	0	0	0	1	0	0	0	0	0	0	0	1	A101h	
R1796 (704h)	Pull Control (DACDAT2)	1	DACD_AT2_PU	DACD_AT2_PD	0	0	0	0	1	0	0	0	0	0	0	0	1	A101h	
R1797 (705h)	GPIO 6	GP6_DIR	GP6_PU	GP6_PD	0	0	GP6_POL	GP6_OP_CFG	GP6_DB	0	GP6_LVL	0	GP6_FN [4:0]				A101h		
R1799 (707h)	GPIO 8	GP8_DIR	GP8_PU	GP8_PD	0	0	GP8_POL	GP8_OP_CFG	GP8_DB	0	GP8_LVL	0	GP8_FN [4:0]				A101h		
R1800 (708h)	GPIO 9	GP9_DIR	GP9_PU	GP9_PD	0	0	GP9_POL	GP9_OP_CFG	GP9_DB	0	GP9_LVL	0	GP9_FN [4:0]				A101h		
R1801 (709h)	GPIO 10	GP10_DIR	GP10_PU	GP10_PD	0	0	GP10_POL	GP10_OP_CFG	GP10_DB	0	GP10_LVL	0	GP10_FN [4:0]				A101h		
R1802 (70Ah)	GPIO 11	GP11_DIR	GP11_PU	GP11_PD	0	0	GP11_POL	GP11_OP_CFG	GP11_DB	0	GP11_LVL	0	GP11_FN [4:0]				A101h		
R1824 (720h)	Pull Control (1)	0	0	0	0	DMIC_DAT2_PU	DMIC_DAT2_PD	DMIC_DAT1_PU	DMIC_DAT1_PD	MCLK1_PU	MCLK1_PD	DACD_AT1_PU	DACD_AT1_PD	DACL_RCLK1_PU	DACL_RCLK1_PD	BCLK1_PU	BCLK1_PD	0000h	
R1825 (721h)	Pull Control (2)	0	0	0	0	0	0	0	ADDR_PD	0	LDO2_ENA_PD	0	LDO1_ENA_PD	0	1	SPKM_ODE_PU	0	0156h	
R1840 (730h)	Interrupt Status 1	0	0	0	0	0	GP11_EINT	GP10_EINT	GP9_EINT	GP8_EINT	0	GP6_EINT	0	0	0	0	GP1_EINT	0000h	
R1841 (731h)	Interrupt Status 2	TEMP_WARN_EINT	DCS_DONE_EINT	WSEQ_DON_EINT	FIFOS_ERR_EINT	AIF2D_RC_SIG_DE_T_EINT	AIF1D_RC_SIG_DE_T_EINT	AIF1D_RC1_SIG_DE_T_EINT	SRC2_LOCK_EINT	SRC1_LOCK_EINT	FLL2_LOCK_EINT	FLL1_LOCK_EINT	0	0	0	0	MICD_EINT	TEMP_SHUT_EINT	0000h
R1842 (732h)	Interrupt Raw Status 2	TEMP_WARN_STS	DCS_DONE_STS	WSEQ_DON_STS	FIFOS_ERR_STS	AIF2D_RC_SIG_DE_T_STS	AIF1D_RC_SIG_DE_T_STS	AIF1D_RC1_SIG_DE_T_STS	SRC2_LOCK_STS	SRC1_LOCK_STS	FLL2_LOCK_STS	FLL1_LOCK_STS	0	0	0	0	0	TEMP_SHUT_STS	0000h

REG	NAME	15	14	13	12	11	10	9	8	7	6	5	4	3	2	1	0	DEFAULT
R1848 (738h)	Interrupt Status 1 Mask	0	0	0	0	0	IM_GP11_EINT	IM_GP10_EINT	IM_GP9_EINT	IM_GP8_EINT	1	IM_GP6_EINT	1	1	1	1	IM_GP1_EINT	07FFh
R1849 (739h)	Interrupt Status 2 Mask	IM_TEMPL_WARN_EINT	IM_DCS_DOE_EINT	IM_WSEQ_DONE_EINT	IM_FIFOS_EINT	IM_AIF2DRC_SIG_DET_EINT	IM_AIF1DRC2_SIG_DET_EINT	IM_AIF1DRC1_SIG_DET_EINT	IM_SRC2_LOCK_EINT	IM_SRC1_LOCK_EINT	IM_FL2_LOCK_EINT	IM_FL1_LOCK_EINT	1	1	1	IM_MICD_EINT	IM_TEMPL_SHUT_EINT	FFFFh
R1856 (740h)	Interrupt Control	0	0	0	0	0	0	0	0	0	0	0	0	0	0	0	IM_IRQ	0000h
R1864 (748h)	IRQ Debounce	0	0	0	0	0	0	0	0	0	0	TEMP_WARN_DB	1	1	1	1	TEMP_SHUT_DB	003Fh
R2304 (900h)	DSP2_Program	0	0	0	1	1	1	0	0	0	0	0	0	0	0	0	DSP2_ENA	1C00h
R2305 (901h)	DSP2_Config	0	0	0	0	0	0	0	0	0	0	MBC_SEL [1:0]	0	0	0	0	MBC_ENA	0000h
R2573 (A0Dh)	DSP2_ExecControl	0	0	0	0	0	0	0	0	0	0	0	0	0	DSP2_STOP	DSP2_RUNR	0	0000h
R12288 (3000h)	Write Sequencer 0	0	0	WSEQ_ADDR0 [13:0]													0039h	
R12289 (3001h)	Write Sequencer 1	0	0	0	0	0	0	0	0	WSEQ_DATA0 [7:0]							001Bh	
R12290 (3002h)	Write Sequencer 2	0	0	0	0	0	WSEQ_DATA_WIDTH0 [2:0]			0	0	0	0	WSEQ_DATA_START0 [3:0]			0402h	
R12291 (3003h)	Write Sequencer 3	0	0	0	0	0	0	0	WSEQ_EOS0	0	0	0	0	WSEQ_DELAY0 [3:0]			0000h	
R12292 (3004h)	Write Sequencer 4	0	0	WSEQ_ADDR1 [13:0]													0001h	
R12293 (3005h)	Write Sequencer 5	0	0	0	0	0	0	0	0	WSEQ_DATA1 [7:0]							0003h	
R12294 (3006h)	Write Sequencer 6	0	0	0	0	0	WSEQ_DATA_WIDTH1 [2:0]			0	0	0	0	WSEQ_DATA_START1 [3:0]			0200h	
R12295 (3007h)	Write Sequencer 7	0	0	0	0	0	0	0	WSEQ_EOS1	0	0	0	0	WSEQ_DELAY1 [3:0]			0009h	
		[similar for WSEQ address 2 ... 126]																
		[similar for WSEQ address 2 ... 126]																
		[similar for WSEQ address 2 ... 126]																
R12796 (31FCh)	Write Sequencer 508	0	0	WSEQ_ADDR127 [13:0]													0000h	
R12797 (31FDh)	Write Sequencer 509	0	0	0	0	0	0	0	0	WSEQ_DATA127 [7:0]							0000h	
R12798 (31FEh)	Write Sequencer 510	0	0	0	0	0	WSEQ_DATA_WIDTH127 [2:0]			0	0	0	0	WSEQ_DATA_START127 [3:0]			0000h	
R12799 (31FFh)	Write Sequencer 511	0	0	0	0	0	0	0	WSEQ_EOS127	0	0	0	0	WSEQ_DELAY127 [3:0]			0000h	

REGISTER BITS BY ADDRESS

REGISTER ADDRESS	BIT	LABEL	DEFAULT	DESCRIPTION	REFER TO
R0 (00h) Software Reset	15:0	SW_RESET [15:0]	0000_0000 _0000_000 0	Writing to this register resets all registers to their default state. (Note - Control Write Sequencer registers are not affected by Software Reset.) Reading from this register will indicate device ID 8958h.	

Register 00h Software Reset

REGISTER ADDRESS	BIT	LABEL	DEFAULT	DESCRIPTION	REFER TO
R1 (01h) Power Management (1)	13	SPKOUTR_ENA	0	SPKMIXR Mixer, SPKRVOL PGA and SPKOUTR Output Enable 0 = Disabled 1 = Enabled	
	12	SPKOUTL_ENA	0	SPKMIXL Mixer, SPKLVOL PGA and SPKOUTL Output Enable 0 = Disabled 1 = Enabled	
	11	HPOUT2_ENA	0	HPOUT2 Output Stage Enable 0 = Disabled 1 = Enabled	
	9	HPOUT1L_ENA	0	Enables HPOUT1L input stage 0 = Disabled 1 = Enabled For normal operation, this bit should be set as the first step of the HPOUT1L Enable sequence.	
	8	HPOUT1R_ENA	0	Enables HPOUT1R input stage 0 = Disabled 1 = Enabled For normal operation, this bit should be set as the first step of the HPOUT1R Enable sequence.	
	5	MICB2_ENA	0	Microphone Bias 2 Enable 0 = Disabled 1 = Enabled	
	4	MICB1_ENA	0	Microphone Bias 1 Enable 0 = Disabled 1 = Enabled	
	2:1	VMID_SEL [1:0]	00	VMID Divider Enable and Select 00 = VMID disabled (for OFF mode) 01 = 2 x 40k divider (for normal operation) 10 = 2 x 240k divider (for low power standby) 11 = Reserved	
	0	BIAS_ENA	0	Enables the Normal bias current generator (for all analogue functions) 0 = Disabled 1 = Enabled	

Register 01h Power Management (1)

REGISTER ADDRESS	BIT	LABEL	DEFAULT	DESCRIPTION	REFER TO
R2 (02h) Power Management (2)	14	TSHUT_ENA	1	Thermal sensor enable 0 = Disabled 1 = Enabled	
	13	TSHUT_OPDIS	1	Thermal shutdown control (Causes audio outputs to be disabled if an overtemperature occurs. The thermal sensor must also be enabled.) 0 = Disabled 1 = Enabled	
	11	OPCLK_ENA	0	GPIO Clock Output (OPCLK) Enable 0 = Disabled 1 = Enabled	
	9	MIXINL_ENA	0	Left Input Mixer Enable (Enables MIXINL and RXVOICE input to MIXINL) 0 = Disabled 1 = Enabled	
	8	MIXINR_ENA	0	Right Input Mixer Enable (Enables MIXINR and RXVOICE input to MIXINR) 0 = Disabled 1 = Enabled	
	7	IN2L_ENA	0	IN2L Input PGA Enable 0 = Disabled 1 = Enabled	
	6	IN1L_ENA	0	IN1L Input PGA Enable 0 = Disabled 1 = Enabled	
	5	IN2R_ENA	0	IN2R Input PGA Enable 0 = Disabled 1 = Enabled	
	4	IN1R_ENA	0	IN1R Input PGA Enable 0 = Disabled 1 = Enabled	

Register 02h Power Management (2)

REGISTER ADDRESS	BIT	LABEL	DEFAULT	DESCRIPTION	REFER TO
R3 (03h) Power Management (3)	13	LINEOUT1N_EN A	0	LINEOUT1N Line Out and LINEOUT1NMIX Enable 0 = Disabled 1 = Enabled	
	12	LINEOUT1P_EN A	0	LINEOUT1P Line Out and LINEOUT1PMIX Enable 0 = Disabled 1 = Enabled	
	11	LINEOUT2N_EN A	0	LINEOUT2N Line Out and LINEOUT2NMIX Enable 0 = Disabled 1 = Enabled	
	10	LINEOUT2P_EN A	0	LINEOUT2P Line Out and LINEOUT2PMIX Enable 0 = Disabled 1 = Enabled	
	9	SPKRVOL_ENA	0	SPKMIXR Mixer and SPKRVOL PGA Enable 0 = Disabled 1 = Enabled Note that SPKMIXR and SPKRVOL are also enabled when SPKOUTR_ENA is set.	

REGISTER ADDRESS	BIT	LABEL	DEFAULT	DESCRIPTION	REFER TO
	8	SPKLVOL_ENA	0	SPKMIXL Mixer and SPKLVOL PGA Enable 0 = Disabled 1 = Enabled Note that SPKMIXL and SPKLVOL are also enabled when SPKOUTL_ENA is set.	
	7	MIXOUTLVOL_ENA	0	MIXOUTL Left Volume Control Enable 0 = Disabled 1 = Enabled	
	6	MIXOUTRVOL_ENA	0	MIXOUTR Right Volume Control Enable 0 = Disabled 1 = Enabled	
	5	MIXOUTL_ENA	0	MIXOUTL Left Output Mixer Enable 0 = Disabled 1 = Enabled	
	4	MIXOUTR_ENA	0	MIXOUTR Right Output Mixer Enable 0 = Disabled 1 = Enabled	

Register 03h Power Management (3)

REGISTER ADDRESS	BIT	LABEL	DEFAULT	DESCRIPTION	REFER TO
R4 (04h) Power Management (4)	13	AIF2ADCL_ENA	0	Enable AIF2ADC (Left) output path 0 = Disabled 1 = Enabled	
	12	AIF2ADCR_ENA	0	Enable AIF2ADC (Right) output path 0 = Disabled 1 = Enabled	
	11	AIF1ADC2L_ENA	0	Enable AIF1ADC2 (Left) output path (AIF1, Timeslot 1) 0 = Disabled 1 = Enabled	
	10	AIF1ADC2R_ENA	0	Enable AIF1ADC2 (Right) output path (AIF1, Timeslot 1) 0 = Disabled 1 = Enabled	
	9	AIF1ADC1L_ENA	0	Enable AIF1ADC1 (Left) output path (AIF1, Timeslot 0) 0 = Disabled 1 = Enabled	
	8	AIF1ADC1R_ENA	0	Enable AIF1ADC1 (Right) output path (AIF1, Timeslot 0) 0 = Disabled 1 = Enabled	
	5	DMIC2L_ENA	0	Digital microphone DMICDAT2 Left channel enable 0 = Disabled 1 = Enabled	
	4	DMIC2R_ENA	0	Digital microphone DMICDAT2 Right channel enable 0 = Disabled 1 = Enabled	
	3	DMIC1L_ENA	0	Digital microphone DMICDAT1 Left channel enable 0 = Disabled 1 = Enabled	
	2	DMIC1R_ENA	0	Digital microphone DMICDAT1 Right channel enable 0 = Disabled 1 = Enabled	
	1	ADCL_ENA	0	Left ADC Enable	

REGISTER ADDRESS	BIT	LABEL	DEFAULT	DESCRIPTION	REFER TO
				0 = Disabled 1 = Enabled	
	0	ADCR_ENA	0	Right ADC Enable 0 = Disabled 1 = Enabled	

Register 04h Power Management (4)

REGISTER ADDRESS	BIT	LABEL	DEFAULT	DESCRIPTION	REFER TO
R5 (05h) Power Management (5)	13	AIF2DACL_ENA	0	Enable AIF2DAC (Left) input path 0 = Disabled 1 = Enabled	
	12	AIF2DACR_ENA	0	Enable AIF2DAC (Right) input path 0 = Disabled 1 = Enabled	
	11	AIF1DAC2L_ENA	0	Enable AIF1DAC2 (Left) input path (AIF1, Timeslot 1) 0 = Disabled 1 = Enabled	
	10	AIF1DAC2R_ENA	0	Enable AIF1DAC2 (Right) input path (AIF1, Timeslot 1) 0 = Disabled 1 = Enabled	
	9	AIF1DAC1L_ENA	0	Enable AIF1DAC1 (Left) input path (AIF1, Timeslot 0) 0 = Disabled 1 = Enabled	
	8	AIF1DAC1R_ENA	0	Enable AIF1DAC1 (Right) input path (AIF1, Timeslot 0) 0 = Disabled 1 = Enabled	
	3	DAC2L_ENA	0	Left DAC2 Enable 0 = Disabled 1 = Enabled	
	2	DAC2R_ENA	0	Right DAC2 Enable 0 = Disabled 1 = Enabled	
	1	DAC1L_ENA	0	Left DAC1 Enable 0 = Disabled 1 = Enabled	
	0	DAC1R_ENA	0	Right DAC1 Enable 0 = Disabled 1 = Enabled	

Register 05h Power Management (5)

REGISTER ADDRESS	BIT	LABEL	DEFAULT	DESCRIPTION	REFER TO
R6 (06h) Power Management (6)	10:9	AIF3ADC_SRC [1:0]	00	AIF3 Mono PCM output source select 00 = None 01 = AIF2ADC (Left) output path 10 = AIF2ADC (Right) output path 11 = Reserved	
	8:7	AIF2DAC_SRC [1:0]	00	AIF2 input path select 00 = Left and Right inputs from AIF2 01 = Left input from AIF2; Right input from AIF3 10 = Left input from AIF3; Right input from AIF2 11 = Reserved	
	5	AIF3_TRI	0	AIF3 Audio Interface tri-state 0 = AIF3 pins operate normally 1 = Tri-state all AIF3 interface pins Note that pins not configured as AIF3 functions are not affected by this register.	
	4:3	AIF3_ADCDAT_SRC [1:0]	00	GPIO9/ADC DAT3 Source select 00 = AIF1 ADCDAT1 01 = AIF2 ADCDAT2 10 = DACDAT2 11 = AIF3 Mono PCM output Note that GPIO9 must be configured as ADCDAT3.	
	2	AIF2_ADCDAT_SRC	0	ADC DAT2 Source select 0 = AIF2 ADCDAT2 1 = GPIO8/DACDAT3 For selection 1, the GPIO8 pin must also be configured as DACDAT3.	
	1	AIF2_DACDAT_SRC	0	AIF2 DACDAT Source select 0 = DACDAT2 1 = GPIO8/DACDAT3 For selection 1, the GPIO8 pin must also be configured as DACDAT3.	
	0	AIF1_DACDAT_SRC	0	AIF1 DACDAT Source select 0 = DACDAT1 1 = GPIO8/DACDAT3 Note that, for selection 1, the GPIO8 pin must be configured as DACDAT3.	

Register 06h Power Management (6)

REGISTER ADDRESS	BIT	LABEL	DEFAULT	DESCRIPTION	REFER TO
R21 (15h) Input Mixer (1)	8	IN1RP_MIXINR_BOOST	0	IN1RP Pin (PGA Bypass) to MIXINR Gain Boost. This bit selects the maximum gain setting of the IN1RP_MIXINR_VOL register. 0 = Maximum gain is +6dB 1 = Maximum gain is +15dB	
	7	IN1LP_MIXINL_BOOST	0	IN1LP Pin (PGA Bypass) to MIXINL Gain Boost. This bit selects the maximum gain setting of the IN1LP_MIXINL_VOL register. 0 = Maximum gain is +6dB 1 = Maximum gain is +15dB	

REGISTER ADDRESS	BIT	LABEL	DEFAULT	DESCRIPTION	REFER TO
	6	INPUTS_CLAMP	0	Input pad VMID clamp 0 = Clamp de-activated 1 = Clamp activated	

Register 15h Input Mixer (1)

REGISTER ADDRESS	BIT	LABEL	DEFAULT	DESCRIPTION	REFER TO
R24 (18h) Left Line Input 1&2 Volume	8	IN1_VU	0	Input PGA Volume Update Writing a 1 to this bit will cause IN1L and IN1R input PGA volumes to be updated simultaneously	
	7	IN1L_MUTE	1	IN1L PGA Mute 0 = Disable Mute 1 = Enable Mute	
	6	IN1L_ZC	0	IN1L PGA Zero Cross Detector 0 = Change gain immediately 1 = Change gain on zero cross only	
	4:0	IN1L_VOL [4:0]	0_1011	IN1L Volume -16.5dB to +30dB in 1.5dB steps	

Register 18h Left Line Input 1&2 Volume

REGISTER ADDRESS	BIT	LABEL	DEFAULT	DESCRIPTION	REFER TO
R25 (19h) Left Line Input 3&4 Volume	8	IN2_VU	0	Input PGA Volume Update Writing a 1 to this bit will cause IN2L and IN2R input PGA volumes to be updated simultaneously	
	7	IN2L_MUTE	1	IN2L PGA Mute 0 = Disable Mute 1 = Enable Mute	
	6	IN2L_ZC	0	IN2L PGA Zero Cross Detector 0 = Change gain immediately 1 = Change gain on zero cross only	
	4:0	IN2L_VOL [4:0]	0_1011	IN2L Volume -16.5dB to +30dB in 1.5dB steps	

Register 19h Left Line Input 3&4 Volume

REGISTER ADDRESS	BIT	LABEL	DEFAULT	DESCRIPTION	REFER TO
R26 (1Ah) Right Line Input 1&2 Volume	8	IN1_VU	0	Input PGA Volume Update Writing a 1 to this bit will cause IN1L and IN1R input PGA volumes to be updated simultaneously	
	7	IN1R_MUTE	1	IN1R PGA Mute 0 = Disable Mute 1 = Enable Mute	
	6	IN1R_ZC	0	IN1R PGA Zero Cross Detector 0 = Change gain immediately 1 = Change gain on zero cross only	
	4:0	IN1R_VOL [4:0]	0_1011	IN1R Volume -16.5dB to +30dB in 1.5dB steps	

Register 1Ah Right Line Input 1&2 Volume

REGISTER ADDRESS	BIT	LABEL	DEFAULT	DESCRIPTION	REFER TO
R27 (1Bh) Right Line Input 3&4 Volume	8	IN2_VU	0	Input PGA Volume Update Writing a 1 to this bit will cause IN2L and IN2R input PGA volumes to be updated simultaneously	
	7	IN2R_MUTE	1	IN2R PGA Mute 0 = Disable Mute 1 = Enable Mute	
	6	IN2R_ZC	0	IN2R PGA Zero Cross Detector 0 = Change gain immediately 1 = Change gain on zero cross only	
	4:0	IN2R_VOL [4:0]	0_1011	IN2R Volume -16.5dB to +30dB in 1.5dB steps	

Register 1Bh Right Line Input 3&4 Volume

REGISTER ADDRESS	BIT	LABEL	DEFAULT	DESCRIPTION	REFER TO
R28 (1Ch) Left Output Volume	8	HPOUT1_VU	0	Headphone Output PGA Volume Update Writing a 1 to this bit will update HPOUT1LVOL and HPOUT1RVOL volumes simultaneously.	
	7	HPOUT1L_ZC	0	HPOUT1LVOL (Left Headphone Output PGA) Zero Cross Enable 0 = Zero cross disabled 1 = Zero cross enabled	
	6	HPOUT1L_MUTE_N	1	HPOUT1LVOL (Left Headphone Output PGA) Mute 0 = Mute 1 = Un-mute	
	5:0	HPOUT1L_VOL [5:0]	10_1101	HPOUT1LVOL (Left Headphone Output PGA) Volume -57dB to +6dB in 1dB steps 00_0000 = -57dB 00_0001 = -56dB ... (1dB steps) 11_1111 = +6dB	

Register 1Ch Left Output Volume

REGISTER ADDRESS	BIT	LABEL	DEFAULT	DESCRIPTION	REFER TO
R29 (1Dh) Right Output Volume	8	HPOUT1_VU	0	Headphone Output PGA Volume Update Writing a 1 to this bit will update HPOUT1LVOL and HPOUT1RVOL volumes simultaneously.	
	7	HPOUT1R_ZC	0	HPOUT1RVOL (Right Headphone Output PGA) Zero Cross Enable 0 = Zero cross disabled 1 = Zero cross enabled	
	6	HPOUT1R_MUTE_N	1	HPOUT1RVOL (Right Headphone Output PGA) Mute 0 = Mute 1 = Un-mute	
	5:0	HPOUT1R_VOL [5:0]	10_1101	HPOUT1RVOL (Right Headphone Output PGA) Volume -57dB to +6dB in 1dB steps 00_0000 = -57dB 00_0001 = -56dB ... (1dB steps) 11_1111 = +6dB	

Register 1Dh Right Output Volume

REGISTER ADDRESS	BIT	LABEL	DEFAULT	DESCRIPTION	REFER TO
R30 (1Eh) Line Outputs Volume	6	LINEOUT1N_MUTE	1	LINEOUT1N Line Output Mute 0 = Un-mute 1 = Mute	
	5	LINEOUT1P_MUTE	1	LINEOUT1P Line Output Mute 0 = Un-mute 1 = Mute	
	4	LINEOUT1_VOL	0	LINEOUT1 Line Output Volume 0 = 0dB 1 = -6dB Applies to both LINEOUT1N and LINEOUT1P	
	2	LINEOUT2N_MUTE	1	LINEOUT2N Line Output Mute 0 = Un-mute 1 = Mute	
	1	LINEOUT2P_MUTE	1	LINEOUT2P Line Output Mute 0 = Un-mute 1 = Mute	
	0	LINEOUT2_VOL	0	LINEOUT2 Line Output Volume 0 = 0dB 1 = -6dB Applies to both LINEOUT2N and LINEOUT2P	

Register 1Eh Line Outputs Volume

REGISTER ADDRESS	BIT	LABEL	DEFAULT	DESCRIPTION	REFER TO
R31 (1Fh) HPOUT2 Volume	5	HPOUT2_MUTE	1	HPOUT2 (Earpiece Driver) Mute 0 = Un-mute 1 = Mute	
	4	HPOUT2_VOL	0	HPOUT2 (Earpiece Driver) Volume 0 = 0dB 1 = -6dB	

Register 1Fh HPOUT2 Volume

REGISTER ADDRESS	BIT	LABEL	DEFAULT	DESCRIPTION	REFER TO
R32 (20h) Left OPGA Volume	8	MIXOUT_VU	0	Mixer Output PGA Volume Update Writing a 1 to this bit will update MIXOUTLVOL and MIXOUTRVOL volumes simultaneously.	
	7	MIXOUTL_ZC	0	MIXOUTLVOL (Left Mixer Output PGA) Zero Cross Enable 0 = Zero cross disabled 1 = Zero cross enabled	
	6	MIXOUTL_MUTE_N	1	MIXOUTLVOL (Left Mixer Output PGA) Mute 0 = Mute 1 = Un-mute	
	5:0	MIXOUTL_VOL [5:0]	11_1001	MIXOUTLVOL (Left Mixer Output PGA) Volume -57dB to +6dB in 1dB steps 00_0000 = -57dB 00_0001 = -56dB ... (1dB steps) 11_1111 = +6dB	

Register 20h Left OPGA Volume

REGISTER ADDRESS	BIT	LABEL	DEFAULT	DESCRIPTION	REFER TO
R33 (21h) Right OPGA Volume	8	MIXOUT_VU	0	Mixer Output PGA Volume Update Writing a 1 to this bit will update MIXOUTLVOL and MIXOUTRVOL volumes simultaneously.	
	7	MIXOUTR_ZC	0	MIXOUTRVOL (Right Mixer Output PGA) Zero Cross Enable 0 = Zero cross disabled 1 = Zero cross enabled	
	6	MIXOUTR_MUTE_N	1	MIXOUTLVOL (Right Mixer Output PGA) Mute 0 = Mute 1 = Un-mute	
	5:0	MIXOUTR_VOL [5:0]	11_1001	MIXOUTRVOL (Right Mixer Output PGA) Volume -57dB to +6dB in 1dB steps 00_0000 = -57dB 00_0001 = -56dB ... (1dB steps) 11_1111 = +6dB	

Register 21h Right OPGA Volume

REGISTER ADDRESS	BIT	LABEL	DEFAULT	DESCRIPTION	REFER TO
R34 (22h) SPKMIXL Attenuation	8	SPKAB_REF_SEL	0	Selects Reference for Speaker in Class AB mode 0 = SPKVDD/2 1 = VMID	
	6	DAC2L_SPKMIXL_VOL	0	Left DAC2 to SPKMIXL Fine Volume Control 0 = 0dB 1 = -3dB	
	5	MIXINL_SPKMIXL_VOL	0	MIXINL (Left ADC bypass) to SPKMIXL Fine Volume Control 0 = 0dB 1 = -3dB	
	4	IN1LP_SPKMIXL_VOL	0	IN1LP to SPKMIXL Fine Volume Control 0 = 0dB 1 = -3dB	
	3	MIXOUTL_SPKMIXL_VOL	0	Left Mixer Output to SPKMIXL Fine Volume Control 0 = 0dB 1 = -3dB	
	2	DAC1L_SPKMIXL_VOL	0	Left DAC1 to SPKMIXL Fine Volume Control 0 = 0dB 1 = -3dB	
	1:0	SPKMIXL_VOL [1:0]	11	Left Speaker Mixer Volume Control 00 = 0dB 01 = -6dB 10 = -12dB 11 = Mute	

Register 22h SPKMIXL Attenuation

REGISTER ADDRESS	BIT	LABEL	DEFAULT	DESCRIPTION	REFER TO
R35 (23h) SPKMIXR Attenuation	8	SPKOUT_CLAS SAB	0	Speaker Class AB Mode Enable 0 = Class D mode 1 = Class AB mode	
	6	DAC2R_SPKMI XR_VOL	0	Right DAC2 to SPKMIXR Fine Volume Control 0 = 0dB 1 = -3dB	
	5	MIXINR_SPKMI XR_VOL	0	MIXINR (Right ADC bypass) to SPKMIXR Fine Volume Control 0 = 0dB 1 = -3dB	
	4	IN1RP_SPKMIX R_VOL	0	IN1RP to SPKMIXR Fine Volume Control 0 = 0dB 1 = -3dB	
	3	MIXOUTR_SPK MIXR_VOL	0	Right Mixer Output to SPKMIXR Fine Volume Control 0 = 0dB 1 = -3dB	
	2	DAC1R_SPKMI XR_VOL	0	Right DAC1 to SPKMIXR Fine Volume Control 0 = 0dB 1 = -3dB	
	1:0	SPKMIXR_VOL [1:0]	11	Right Speaker Mixer Volume Control 00 = 0dB 01 = -6dB 10 = -12dB 11 = Mute	

Register 23h SPKMIXR Attenuation

REGISTER ADDRESS	BIT	LABEL	DEFAULT	DESCRIPTION	REFER TO
R36 (24h) SPKOUT Mixers	5	IN2LRP_TO_SP KOUTL	0	Direct Voice (VRXN-VRXP) to Left Speaker Mute 0 = Mute 1 = Un-mute	
	4	SPKMIXL_TO_S PKOUTL	1	SPKMIXL Left Speaker Mixer to Left Speaker Mute 0 = Mute 1 = Un-mute	
	3	SPKMIXR_TO_ SPKOUTL	0	SPKMIXR Right Speaker Mixer to Left Speaker Mute 0 = Mute 1 = Un-mute	
	2	IN2LRP_TO_SP KOUTR	0	Direct Voice (VRXN-VRXP) to Right Speaker Mute 0 = Mute 1 = Un-mute	
	1	SPKMIXL_TO_S PKOUTR	0	SPKMIXL Left Speaker Mixer to Right Speaker Mute 0 = Mute 1 = Un-mute	
	0	SPKMIXR_TO_ SPKOUTR	1	SPKMIXR Right Speaker Mixer to Right Speaker Mute 0 = Mute 1 = Un-mute	

Register 24h SPKOUT Mixers

REGISTER ADDRESS	BIT	LABEL	DEFAULT	DESCRIPTION	REFER TO
R37 (25h) ClassD	5:3	SPKOUTL_BOOST [2:0]	000	Left Speaker Gain Boost 000 = 1.00x boost (+0dB) 001 = 1.19x boost (+1.5dB) 010 = 1.41x boost (+3.0dB) 011 = 1.68x boost (+4.5dB) 100 = 2.00x boost (+6.0dB) 101 = 2.37x boost (+7.5dB) 110 = 2.81x boost (+9.0dB) 111 = 3.98x boost (+12.0dB)	
	2:0	SPKOUTR_BOOST [2:0]	000	Right Speaker Gain Boost 000 = 1.00x boost (+0dB) 001 = 1.19x boost (+1.5dB) 010 = 1.41x boost (+3.0dB) 011 = 1.68x boost (+4.5dB) 100 = 2.00x boost (+6.0dB) 101 = 2.37x boost (+7.5dB) 110 = 2.81x boost (+9.0dB) 111 = 3.98x boost (+12.0dB)	

Register 25h ClassD

REGISTER ADDRESS	BIT	LABEL	DEFAULT	DESCRIPTION	REFER TO
R38 (26h) Speaker Volume Left	8	SPKOUT_VU	0	Speaker Output PGA Volume Update Writing a 1 to this bit will update SPKLVOL and SPKRVOL volumes simultaneously.	
	7	SPKOUTL_ZC	0	SPKLVOL (Left Speaker Output PGA) Zero Cross Enable 0 = Zero cross disabled 1 = Zero cross enabled	
	6	SPKOUTL_MUTE_N	1	SPKLVOL (Left Speaker Output PGA) Mute 0 = Mute 1 = Un-mute	
	5:0	SPKOUTL_VOL [5:0]	11_1001	SPKLVOL (Left Speaker Output PGA) Volume -57dB to +6dB in 1dB steps 00_0000 = -57dB 00_0001 = -56dB ... (1dB steps) 11_1111 = +6dB	

Register 26h Speaker Volume Left

REGISTER ADDRESS	BIT	LABEL	DEFAULT	DESCRIPTION	REFER TO
R39 (27h) Speaker Volume Right	8	SPKOUT_VU	0	Speaker Output PGA Volume Update Writing a 1 to this bit will update SPKLVOL and SPKRVOL volumes simultaneously.	
	7	SPKOUTR_ZC	0	SPKRVOL (Right Speaker Output PGA) Zero Cross Enable 0 = Zero cross disabled 1 = Zero cross enabled	
	6	SPKOUTR_MUTE_N	1	SPKRVOL (Right Speaker Output PGA) Mute 0 = Mute 1 = Un-mute	
	5:0	SPKOUTR_VOL	11_1001	SPKRVOL (Right Speaker Output PGA) Volume	

REGISTER ADDRESS	BIT	LABEL	DEFAULT	DESCRIPTION	REFER TO
		[5:0]		-57dB to +6dB in 1dB steps 00_0000 = -57dB 00_0001 = -56dB ... (1dB steps) 11_1111 = +6dB	

Register 27h Speaker Volume Right

REGISTER ADDRESS	BIT	LABEL	DEFAULT	DESCRIPTION	REFER TO
R40 (28h) Input Mixer (2)	7	IN2LP_TO_IN2L	0	IN2L PGA Non-Inverting Input Select 0 = Connected to VMID 1 = Connected to IN2LP Note that VMID_BUF_ENA must be set when using IN2L connected to VMID.	
	6	IN2LN_TO_IN2L	0	IN2L PGA Inverting Input Select 0 = Not connected 1 = Connected to IN2LN	
	5	IN1LP_TO_IN1L	0	IN1L PGA Non-Inverting Input Select 0 = Connected to VMID 1 = Connected to IN1LP Note that VMID_BUF_ENA must be set when using IN1L connected to VMID.	
	4	IN1LN_TO_IN1L	0	IN1L PGA Inverting Input Select 0 = Not connected 1 = Connected to IN1LN	
	3	IN2RP_TO_IN2R	0	IN2R PGA Non-Inverting Input Select 0 = Connected to VMID 1 = Connected to IN2RP Note that VMID_BUF_ENA must be set when using IN2R connected to VMID.	
	2	IN2RN_TO_IN2R	0	IN2R PGA Inverting Input Select 0 = Not connected 1 = Connected to IN2RN	
	1	IN1RP_TO_IN1R	0	IN1R PGA Non-Inverting Input Select 0 = Connected to VMID 1 = Connected to IN1RP Note that VMID_BUF_ENA must be set when using IN1R connected to VMID.	
	0	IN1RN_TO_IN1R	0	IN1R PGA Inverting Input Select 0 = Not connected 1 = Connected to IN1RN	

Register 28h Input Mixer (2)

REGISTER ADDRESS	BIT	LABEL	DEFAULT	DESCRIPTION	REFER TO
R41 (29h) Input Mixer (3)	8	IN2L_TO_MIXINL	0	IN2L PGA Output to MIXINL Mute 0 = Mute 1 = Un-Mute	
	7	IN2L_MIXINL_VOL	0	IN2L PGA Output to MIXINL Gain 0 = 0dB 1 = +30dB	
	5	IN1L_TO_MIXINL	0	IN1L PGA Output to MIXINL Mute 0 = Mute 1 = Un-Mute	
	4	IN1L_MIXINL_VOL	0	IN1L PGA Output to MIXINL Gain 0 = 0dB 1 = +30dB	
	2:0	MIXOUTL_MIXINL_VOL [2:0]	000	Record Path MIXOUTL to MIXINL Gain and Mute 000 = Mute 001 = -12dB 010 = -9dB 011 = -6dB 100 = -3dB 101 = 0dB 110 = +3dB 111 = +6dB	

Register 29h Input Mixer (3)

REGISTER ADDRESS	BIT	LABEL	DEFAULT	DESCRIPTION	REFER TO
R42 (2Ah) Input Mixer (4)	8	IN2R_TO_MIXINR	0	IN2R PGA Output to MIXINR Mute 0 = Mute 1 = Un-Mute	
	7	IN2R_MIXINR_VOL	0	IN2R PGA Output to MIXINR Gain 0 = 0dB 1 = +30dB	
	5	IN1R_TO_MIXINR	0	IN1R PGA Output to MIXINR Mute 0 = Mute 1 = Un-Mute	
	4	IN1R_MIXINR_VOL	0	IN1R PGA Output to MIXINR Gain 0 = 0dB 1 = +30dB	
	2:0	MIXOUTR_MIXINR_VOL [2:0]	000	Record Path MIXOUTR to MIXINR Gain and Mute 000 = Mute 001 = -12dB 010 = -9dB 011 = -6dB 100 = -3dB 101 = 0dB 110 = +3dB 111 = +6dB	

Register 2Ah Input Mixer (4)

REGISTER ADDRESS	BIT	LABEL	DEFAULT	DESCRIPTION	REFER TO
R43 (2Bh) Input Mixer (5)	8:6	IN1LP_MIXINL_VOL [2:0]	000	IN1LP Pin (PGA Bypass) to MIXINL Gain and Mute 000 = Mute 001 = -12dB 010 = -9dB 011 = -6dB 100 = -3dB 101 = 0dB 110 = +3dB 111 = +6dB (see note below). When IN1LP_MIXINL_BOOST is set, then the maximum gain setting is increased to +15dB, ie. 111 = +15dB. Note that VMID_BUF_ENA must be set when using the IN1LP (PGA Bypass) input to MIXINL.	
	2:0	IN2LRP_MIXINL_VOL [2:0]	000	RXVOICE Differential Input (VRXP-VRXN) to MIXINL Gain and Mute 000 = Mute 001 = -12dB 010 = -9dB 011 = -6dB 100 = -3dB 101 = 0dB 110 = +3dB 111 = +6dB	

Register 2Bh Input Mixer (5)

REGISTER ADDRESS	BIT	LABEL	DEFAULT	DESCRIPTION	REFER TO
R44 (2Ch) Input Mixer (6)	8:6	IN1RP_MIXINR_VOL [2:0]	000	IN1RP Pin (PGA Bypass) to MIXINR Gain and Mute 000 = Mute 001 = -12dB 010 = -9dB 011 = -6dB 100 = -3dB 101 = 0dB 110 = +3dB 111 = +6dB (see note below). When IN1RP_MIXINR_BOOST is set, then the maximum gain setting is increased to +15dB, ie. 111 = +15dB. Note that VMID_BUF_ENA must be set when using the IN1RP (PGA Bypass) input to MIXINR.	
	2:0	IN2LRP_MIXINR_VOL [2:0]	000	RXVOICE Differential Input (VRXP-VRXN) to MIXINR Gain and Mute 000 = Mute 001 = -12dB 010 = -9dB 011 = -6dB 100 = -3dB 101 = 0dB 110 = +3dB 111 = +6dB	

Register 2Ch Input Mixer (6)

REGISTER ADDRESS	BIT	LABEL	DEFAULT	DESCRIPTION	REFER TO
R45 (2Dh) Output Mixer (1)	8	DAC1L_TO_HP OUT1L	0	HPOUT1LVOL (Left Headphone Output PGA) Input Select 0 = MIXOUTL 1 = DAC1L	
	7	MIXINR_TO_MI XOUTL	0	MIXINR Output (Right ADC bypass) to MIXOUTL Mute 0 = Mute 1 = Un-mute	
	6	MIXINL_TO_MI XOUTL	0	MIXINL Output (Left ADC bypass) to MIXOUTL Mute 0 = Mute 1 = Un-mute	
	5	IN2RN_TO_MIX OUTL	0	IN2RN to MIXOUTL Mute 0 = Mute 1 = Un-mute Note that VMID_BUF_ENA must be set when using the IN2RN input to MIXOUTL.	
	4	IN2LN_TO_MIX OUTL	0	IN2LN to MIXOUTL Mute 0 = Mute 1 = Un-mute Note that VMID_BUF_ENA must be set when using the IN2LN input to MIXOUTL.	
	3	IN1R_TO_MIXO UTL	0	IN1R PGA Output to MIXOUTL Mute 0 = Mute 1 = Un-mute	
	2	IN1L_TO_MIXO UTL	0	IN1L PGA Output to MIXOUTL Mute 0 = Mute 1 = Un-mute	
	1	IN2LP_TO_MIX OUTL	0	IN2LP to MIXOUTL Mute 0 = Mute 1 = Un-mute Note that VMID_BUF_ENA must be set when using the IN2LP input to MIXOUTL.	
	0	DAC1L_TO_MIX OUTL	0	Left DAC1 to MIXOUTL Mute 0 = Mute 1 = Un-mute	

Register 2Dh Output Mixer (1)

REGISTER ADDRESS	BIT	LABEL	DEFAULT	DESCRIPTION	REFER TO
R46 (2Eh) Output Mixer (2)	8	DAC1R_TO_HP OUT1R	0	HPOUT1RVOL (Right Headphone Output PGA) Input Select 0 = MIXOUTR 1 = DAC1R	
	7	MIXINL_TO_MI XOUTR	0	MIXINL Output (Left ADC bypass) to MIXOUTR Mute 0 = Mute 1 = Un-mute	
	6	MIXINR_TO_MI XOUTR	0	MIXINR Output (Right ADC bypass) to MIXOUTR Mute 0 = Mute 1 = Un-mute	
	5	IN2LN_TO_MIX OUTR	0	IN2LN to MIXOUTR Mute 0 = Mute 1 = Un-mute Note that VMID_BUF_ENA must be set when using the IN2LN input to MIXOUTR.	

REGISTER ADDRESS	BIT	LABEL	DEFAULT	DESCRIPTION	REFER TO
	4	IN2RN_TO_MIXOUTR	0	IN2RN to MIXOUTR Mute 0 = Mute 1 = Un-mute Note that VMID_BUF_ENA must be set when using the IN2RN input to MIXOUTR.	
	3	IN1L_TO_MIXOUTR	0	IN1L PGA Output to MIXOUTR Mute 0 = Mute 1 = Un-mute	
	2	IN1R_TO_MIXOUTR	0	IN1R PGA Output to MIXOUTR Mute 0 = Mute 1 = Un-mute	
	1	IN2RP_TO_MIXOUTR	0	IN2RP to MIXOUTR Mute 0 = Mute 1 = Un-mute Note that VMID_BUF_ENA must be set when using the IN2RP input to MIXOUTR.	
	0	DAC1R_TO_MIXOUTR	0	Right DAC1 to MIXOUTR Mute 0 = Mute 1 = Un-mute	

Register 2Eh Output Mixer (2)

REGISTER ADDRESS	BIT	LABEL	DEFAULT	DESCRIPTION	REFER TO
R47 (2Fh) Output Mixer (3)	11:9	IN2LP_MIXOUTL_VOL [2:0]	000	IN2LP to MIXOUTL Volume 0dB to -9dB in 3dB steps X00 = 0dB X01 = -3dB X10 = -6dB X11 = -9dB	
	8:6	IN2LN_MIXOUTL_VOL [2:0]	000	IN2LN to MIXOUTL Volume 0dB to -9dB in 3dB steps X00 = 0dB X01 = -3dB X10 = -6dB X11 = -9dB	
	5:3	IN1R_MIXOUTL_VOL [2:0]	000	IN1R PGA Output to MIXOUTL Volume 0dB to -9dB in 3dB steps X00 = 0dB X01 = -3dB X10 = -6dB X11 = -9dB	
	2:0	IN1L_MIXOUTL_VOL [2:0]	000	IN1L PGA Output to MIXOUTL Volume 0dB to -9dB in 3dB steps X00 = 0dB X01 = -3dB X10 = -6dB X11 = -9dB	

Register 2Fh Output Mixer (3)

REGISTER ADDRESS	BIT	LABEL	DEFAULT	DESCRIPTION	REFER TO
R48 (30h) Output Mixer (4)	11:9	IN2RP_MIXOUT R_VOL [2:0]	000	IN2RP to MIXOUTR Volume 0dB to -9dB in 3dB steps X00 = 0dB X01 = -3dB X10 = -6dB X11 = -9dB	
	8:6	IN2RN_MIXOUT R_VOL [2:0]	000	IN2RN to MIXOUTR Volume 0dB to -9dB in 3dB steps X00 = 0dB X01 = -3dB X10 = -6dB X11 = -9dB	
	5:3	IN1L_MIXOUTR _VOL [2:0]	000	IN1L PGA Output to MIXOUTR Volume 0dB to -9dB in 3dB steps X00 = 0dB X01 = -3dB X10 = -6dB X11 = -9dB	
	2:0	IN1R_MIXOUTR _VOL [2:0]	000	IN1R PGA Output to MIXOUTR Volume 0dB to -9dB in 3dB steps X00 = 0dB X01 = -3dB X10 = -6dB X11 = -9dB	

Register 30h Output Mixer (4)

REGISTER ADDRESS	BIT	LABEL	DEFAULT	DESCRIPTION	REFER TO
R49 (31h) Output Mixer (5)	11:9	DAC1L_MIXOU TL_VOL [2:0]	000	Left DAC1 to MIXOUTL Volume 0dB to -9dB in 3dB steps X00 = 0dB X01 = -3dB X10 = -6dB X11 = -9dB	
	8:6	IN2RN_MIXOUT L_VOL [2:0]	000	IN2RN to MIXOUTL Volume 0dB to -9dB in 3dB steps X00 = 0dB X01 = -3dB X10 = -6dB X11 = -9dB	
	5:3	MIXINR_MIXOU TL_VOL [2:0]	000	MIXINR Output (Right ADC bypass) to MIXOUTL Volume 0dB to -9dB in 3dB steps X00 = 0dB X01 = -3dB X10 = -6dB X11 = -9dB	
	2:0	MIXINL_MIXOU TL_VOL [2:0]	000	MIXINL Output (Left ADC bypass) to MIXOUTL Volume 0dB to -9dB in 3dB steps X00 = 0dB X01 = -3dB X10 = -6dB X11 = -9dB	

Register 31h Output Mixer (5)

REGISTER ADDRESS	BIT	LABEL	DEFAULT	DESCRIPTION	REFER TO
R50 (32h) Output Mixer (6)	11:9	DAC1R_MIXOUTR_VOL [2:0]	000	Right DAC1 to MIXOUTR Volume 0dB to -9dB in 3dB steps X00 = 0dB X01 = -3dB X10 = -6dB X11 = -9dB	
	8:6	IN2LN_MIXOUTR_VOL [2:0]	000	IN2LN to MIXOUTR Volume 0dB to -9dB in 3dB steps X00 = 0dB X01 = -3dB X10 = -6dB X11 = -9dB	
	5:3	MIXINL_MIXOUTR_VOL [2:0]	000	MIXINL Output (Left ADC bypass) to MIXOUTR Volume 0dB to -9dB in 3dB steps X00 = 0dB X01 = -3dB X10 = -6dB X11 = -9dB	
	2:0	MIXINR_MIXOUTR_VOL [2:0]	000	MIXINR Output (Right ADC bypass) to MIXOUTR Volume 0dB to -9dB in 3dB steps X00 = 0dB X01 = -3dB X10 = -6dB X11 = -9dB	

Register 32h Output Mixer (6)

REGISTER ADDRESS	BIT	LABEL	DEFAULT	DESCRIPTION	REFER TO
R51 (33h) HPOUT2 Mixer	5	IN2LRP_TO_HP OUT2	0	Direct Voice (VRXN-VRXP) to Earpiece Driver 0 = Mute 1 = Un-mute	
	4	MIXOUTLVOL_ TO_HPOUT2	0	MIXOUTLVOL (Left Output Mixer PGA) to Earpiece Driver 0 = Mute 1 = Un-mute	
	3	MIXOUTRVOL_ TO_HPOUT2	0	MIXOUTRVOL (Right Output Mixer PGA) to Earpiece Driver 0 = Mute 1 = Un-mute	

Register 33h HPOUT2 Mixer

REGISTER ADDRESS	BIT	LABEL	DEFAULT	DESCRIPTION	REFER TO
R52 (34h) Line Mixer (1)	6	MIXOUTL_TO_L INEOUT1N	0	MIXOUTL to Single-Ended Line Output on LINEOUT1N 0 = Mute 1 = Un-mute (LINEOUT1_MODE = 1)	
	5	MIXOUTR_TO_ LINEOUT1N	0	MIXOUTR to Single-Ended Line Output on LINEOUT1N 0 = Mute 1 = Un-mute (LINEOUT1_MODE = 1)	

REGISTER ADDRESS	BIT	LABEL	DEFAULT	DESCRIPTION	REFER TO
	4	LINEOUT1_MODE	0	LINEOUT1 Mode Select 0 = Differential 1 = Single-Ended	
	2	IN1R_TO_LINEOUT1P	0	IN1R Input PGA to Differential Line Output on LINEOUT1 0 = Mute 1 = Un-mute (LINEOUT1_MODE = 0)	
	1	IN1L_TO_LINEOUT1P	0	IN1L Input PGA to Differential Line Output on LINEOUT1 0 = Mute 1 = Un-mute (LINEOUT1_MODE = 0)	
	0	MIXOUTL_TO_LINEOUT1P	0	Differential Mode (LINEOUT1_MODE = 0): MIXOUTL to Differential Output on LINEOUT1 0 = Mute 1 = Un-mute Single Ended Mode (LINEOUT1_MODE = 1): MIXOUTL to Single-Ended Line Output on LINEOUT1P 0 = Mute 1 = Un-mute	

Register 34h Line Mixer (1)

REGISTER ADDRESS	BIT	LABEL	DEFAULT	DESCRIPTION	REFER TO
R53 (35h) Line Mixer (2)	6	MIXOUTR_TO_LINEOUT2N	0	MIXOUTR to Single-Ended Line Output on LINEOUT2N 0 = Mute 1 = Un-mute (LINEOUT2_MODE = 1)	
	5	MIXOUTL_TO_LINEOUT2N	0	MIXOUTL to Single-Ended Line Output on LINEOUT2N 0 = Mute 1 = Un-mute (LINEOUT2_MODE = 1)	
	4	LINEOUT2_MODE	0	LINEOUT2 Mode Select 0 = Differential 1 = Single-Ended	
	2	IN1L_TO_LINEOUT2P	0	IN1L Input PGA to Differential Line Output on LINEOUT2 0 = Mute 1 = Un-mute (LINEOUT2_MODE = 0)	
	1	IN1R_TO_LINEOUT2P	0	IN1R Input PGA to Differential Line Output on LINEOUT2 0 = Mute 1 = Un-mute (LINEOUT2_MODE = 0)	
	0	MIXOUTR_TO_LINEOUT2P	0	Differential Mode (LINEOUT2_MODE = 0): MIXOUTR to Differential Output on LINEOUT2 0 = Mute 1 = Un-mute Single-Ended Mode (LINEOUT2_MODE = 0): MIXOUTR to Single-Ended Line Output on LINEOUT2P 0 = Mute 1 = Un-mute	

Register 35h Line Mixer (2)

REGISTER ADDRESS	BIT	LABEL	DEFAULT	DESCRIPTION	REFER TO
R54 (36h) Speaker Mixer	9	DAC2L_TO_SP KMIXL	0	Left DAC2 to SPKMIXL Mute 0 = Mute 1 = Un-mute	
	8	DAC2R_TO_SP KMIXR	0	Right DAC2 to SPKMIXR Mute 0 = Mute 1 = Un-mute	
	7	MIXINL_TO_SP KMIXL	0	MIXINL (Left ADC bypass) to SPKMIXL Mute 0 = Mute 1 = Un-mute	
	6	MIXINR_TO_SP KMIXR	0	MIXINR (Right ADC bypass) to SPKMIXR Mute 0 = Mute 1 = Un-mute	
	5	IN1LP_TO_SPK MIXL	0	IN1LP to SPKMIXL Mute 0 = Mute 1 = Un-mute Note that VMID_BUF_ENA must be set when using the IN1LP input to SPKMIXL.	
	4	IN1RP_TO_SPK MIXR	0	IN1RP to SPKMIXR Mute 0 = Mute 1 = Un-mute Note that VMID_BUF_ENA must be set when using the IN1RP input to SPKMIXR.	
	3	MIXOUTL_TO_ SPKMIXL	0	Left Mixer Output to SPKMIXL Mute 0 = Mute 1 = Un-mute	
	2	MIXOUTR_TO_ SPKMIXR	0	Right Mixer Output to SPKMIXR Mute 0 = Mute 1 = Un-mute	
	1	DAC1L_TO_SP KMIXL	0	Left DAC1 to SPKMIXL Mute 0 = Mute 1 = Un-mute	
	0	DAC1R_TO_SP KMIXR	0	Right DAC1 to SPKMIXR Mute 0 = Mute 1 = Un-mute	

Register 36h Speaker Mixer

REGISTER ADDRESS	BIT	LABEL	DEFAULT	DESCRIPTION	REFER TO
R55 (37h) Additional Control	7	LINEOUT1_FB	0	Enable ground loop noise feedback on LINEOUT1 0 = Disabled 1 = Enabled	
	6	LINEOUT2_FB	0	Enable ground loop noise feedback on LINEOUT2 0 = Disabled 1 = Enabled	
	0	VROI	0	Buffered VMID to Analogue Line Output Resistance (Disabled Outputs) 0 = 20kΩ from buffered VMID to output 1 = 500Ω from buffered VMID to output	

Register 37h Additional Control

REGISTER ADDRESS	BIT	LABEL	DEFAULT	DESCRIPTION	REFER TO
R56 (38h) AntiPOP (1)	7	LINEOUT_VMID_BUF_ENA	0	Enables VMID reference for line outputs in single-ended mode 0 = Disabled 1 = Enabled	
	6	HPOUT2_IN_ENA	0	HPOUT2MIX Mixer and Input Stage Enable 0 = Disabled 1 = Enabled	
	5	LINEOUT1_DISCH	0	Discharges LINEOUT1P and LINEOUT1N outputs 0 = Not active 1 = Actively discharging LINEOUT1P and LINEOUT1N	
	4	LINEOUT2_DISCH	0	Discharges LINEOUT2P and LINEOUT2N outputs 0 = Not active 1 = Actively discharging LINEOUT2P and LINEOUT2N	

Register 38h AntiPOP (1)

REGISTER ADDRESS	BIT	LABEL	DEFAULT	DESCRIPTION	REFER TO
R57 (39h) AntiPOP (2)	6:5	VMID_RAMP [1:0]	00	VMID soft start enable / slew rate control 00 = Normal slow start 01 = Normal fast start 10 = Soft slow start 11 = Soft fast start If VMID_RAMP = 1X is selected for VMID start-up or shut-down, then the soft-start circuit must be reset by setting VMID_RAMP=00 after VMID is disabled, before VMID is re-enabled. VMID is disabled / enabled using the VMID_SEL register.	
	3	VMID_BUF_ENA	0	VMID Buffer Enable 0 = Disabled 1 = Enabled (provided VMID_SEL > 00)	
	2	STARTUP_BIAS_ENA	0	Enables the Start-Up bias current generator 0 = Disabled 1 = Enabled	
	1	BIAS_SRC	0	Selects the bias current source 0 = Normal bias 1 = Start-Up bias	
	0	VMID_DISCH	0	Connects VMID to ground 0 = Disabled 1 = Enabled	

Register 39h AntiPOP (2)

REGISTER ADDRESS	BIT	LABEL	DEFAULT	DESCRIPTION	REFER TO
R59 (3Bh) LDO 1	3:1	LDO1_VSEL [2:0]	110	LDO1 Output Voltage Select 2.4V to 3.1V in 100mV steps 000 = 2.4V 001 = 2.5V 010 = 2.6V 011 = 2.7V 100 = 2.8V 101 = 2.9V 110 = 3.0V	

REGISTER ADDRESS	BIT	LABEL	DEFAULT	DESCRIPTION	REFER TO
				111 = 3.1V	
	0	LDO1_DISCH	1	LDO1 Discharge Select 0 = LDO1 floating when disabled 1 = LDO1 discharged when disabled	

Register 3Bh LDO 1

REGISTER ADDRESS	BIT	LABEL	DEFAULT	DESCRIPTION	REFER TO
R60 (3Ch) LDO 2	2:1	LDO2_VSEL [1:0]	10	LDO2 Output Voltage Select 1.1V to 1.3V in 100mV steps 00 = Reserved 01 = 1.1V 10 = 1.2V 11 = 1.3V	
	0	LDO2_DISCH	1	LDO2 Discharge Select 0 = LDO2 floating when disabled 1 = LDO2 discharged when disabled	

Register 3Ch LDO 2

REGISTER ADDRESS	BIT	LABEL	DEFAULT	DESCRIPTION	REFER TO
R61 (3Dh) MICBIAS1	5	MICB1_RATE	1	Microphone Bias 1 Rate 0 = Fast start-up / shut-down 1 = Pop-free start-up / shut-down	
	4	MICB1_MODE	1	Microphone Bias 1 Mode 0 = Regulator mode 1 = Bypass mode	
	3:1	MICB1_LVL [2:0]	100	Microphone Bias 1 Voltage Control (when MICB1_MODE = 0) 000 = 1.5V 001 = 1.8V 010 = 1.9V 011 = 2.0V 100 = 2.2V 101 = 2.4V 110 = 2.5V 111 = 2.6V	
	0	MICB1_DISCH	1	Microphone Bias 1 Discharge 0 = MICBIAS1 floating when disabled 1 = MICBIAS1 discharged when disabled	

Register 3Dh MICBIAS1

REGISTER ADDRESS	BIT	LABEL	DEFAULT	DESCRIPTION	REFER TO
R62 (3Eh) MICBIAS2	5	MICB2_RATE	1	Microphone Bias 2 Rate 0 = Fast start-up / shut-down 1 = Pop-free start-up / shut-down	
	4	MICB2_MODE	1	Microphone Bias 2 Mode 0 = Regulator mode 1 = Bypass mode	

REGISTER ADDRESS	BIT	LABEL	DEFAULT	DESCRIPTION	REFER TO
	3:1	MICB2_LVL [2:0]	100	Microphone Bias 2 Voltage Control (when MICB2_MODE = 0) 000 = 1.5V 001 = 1.8V 010 = 1.9V 011 = 2.0V 100 = 2.2V 101 = 2.4V 110 = 2.5V 111 = 2.6V	
	0	MICB2_DISCH	1	Microphone Bias 2 Discharge 0 = MICBIAS2 floating when disabled 1 = MICBIAS2 discharged when disabled	

Register 3Eh MICBIAS2

REGISTER ADDRESS	BIT	LABEL	DEFAULT	DESCRIPTION	REFER TO
R76 (4Ch) Charge Pump (1)	15	CP_ENA	0	Enable charge-pump digits 0 = Disable 1 = Enable	

Register 4Ch Charge Pump (1)

REGISTER ADDRESS	BIT	LABEL	DEFAULT	DESCRIPTION	REFER TO
R77 (4Dh) Charge Pump (2)	15	CP_DISCH	1	Charge Pump Discharge Select 0 = Charge Pump outputs floating when disabled 1 = Charge Pump outputs discharged when disabled	

Register 4Dh Charge Pump (2)

REGISTER ADDRESS	BIT	LABEL	DEFAULT	DESCRIPTION	REFER TO
R81 (51h) Class W (1)	9:8	CP_DYN_SRC_SEL [1:0]	00	Selects the digital audio source for envelope tracking 00 = AIF1, DAC Timeslot 0 01 = AIF1, DAC Timeslot 1 10 = AIF2, DAC data 11 = Reserved	
	0	CP_DYN_PWR	0	Enable dynamic charge pump power control 0 = charge pump controlled by volume register settings (Class G) 1 = charge pump controlled by real-time audio level (Class W)	

Register 51h Class W (1)

REGISTER ADDRESS	BIT	LABEL	DEFAULT	DESCRIPTION	REFER TO
R84 (54h) DC Servo (1)	13	DCS_TRIG_SIN_GLE_1	0	Writing 1 to this bit selects a single DC offset correction for HPOUT1R. In readback, a value of 1 indicates that the DC Servo single correction is in progress.	

REGISTER ADDRESS	BIT	LABEL	DEFAULT	DESCRIPTION	REFER TO
	12	DCS_TRIG_SINGLE_0	0	Writing 1 to this bit selects a single DC offset correction for HPOUT1L. In readback, a value of 1 indicates that the DC Servo single correction is in progress.	
	9	DCS_TRIG_SERIES_1	0	Writing 1 to this bit selects a series of DC offset corrections for HPOUT1R. In readback, a value of 1 indicates that the DC Servo DAC Write correction is in progress.	
	8	DCS_TRIG_SERIES_0	0	Writing 1 to this bit selects a series of DC offset corrections for HPOUT1L. In readback, a value of 1 indicates that the DC Servo DAC Write correction is in progress.	
	5	DCS_TRIG_STARTUP_1	0	Writing 1 to this bit selects Start-Up DC Servo mode for HPOUT1R. In readback, a value of 1 indicates that the DC Servo Start-Up correction is in progress.	
	4	DCS_TRIG_STARTUP_0	0	Writing 1 to this bit selects Start-Up DC Servo mode for HPOUT1L. In readback, a value of 1 indicates that the DC Servo Start-Up correction is in progress.	
	3	DCS_TRIG_DAC_WR_1	0	Writing 1 to this bit selects DAC Write DC Servo mode for HPOUT1R. In readback, a value of 1 indicates that the DC Servo DAC Write correction is in progress.	
	2	DCS_TRIG_DAC_WR_0	0	Writing 1 to this bit selects DAC Write DC Servo mode for HPOUT1L. In readback, a value of 1 indicates that the DC Servo DAC Write correction is in progress.	
	1	DCS_ENA_CHANNEL_1	0	DC Servo enable for HPOUT1R 0 = Disabled 1 = Enabled	
	0	DCS_ENA_CHANNEL_0	0	DC Servo enable for HPOUT1L 0 = Disabled 1 = Enabled	

Register 54h DC Servo (1)

REGISTER ADDRESS	BIT	LABEL	DEFAULT	DESCRIPTION	REFER TO
R85 (55h) DC Servo (2)	11:5	DCS_SERIES_NO_01 [6:0]	010_1010	Number of DC Servo updates to perform in a series event. 0 = 1 update 1 = 2 updates ... 127 = 128 updates	
	3:0	DCS_TIMER_PERIOD_01 [3:0]	1010	Time between periodic updates. Time is calculated as $0.251s \times (2^{\text{PERIOD}})$, where PERIOD = DCS_TIMER_PERIOD_01. 0000 = Off 0001 = 0.502s 1010 = 257s (4min 17s) 1111 = 8225s (2hr 17min)	

Register 55h DC Servo (2)

REGISTER ADDRESS	BIT	LABEL	DEFAULT	DESCRIPTION	REFER TO
R87 (57h) DC Servo (4)	15:8	DCS_DAC_WR_VAL_1 [7:0]	0000_0000	Writing to this field sets the DC Offset value for HPOUT1R in DAC Write DC Servo mode. Reading this field gives the current DC Offset value for HPOUT1R. Two's complement format. LSB is 0.25mV. Range is -32mV to +31.75mV	
	7:0	DCS_DAC_WR_VAL_0 [7:0]	0000_0000	Writing to this field sets the DC Offset value for HPOUT1L in DAC Write DC Servo mode. Reading this field gives the current DC Offset value for HPOUT1L. Two's complement format. LSB is 0.25mV. Range is -32mV to +31.75mV	

Register 57h DC Servo (4)

REGISTER ADDRESS	BIT	LABEL	DEFAULT	DESCRIPTION	REFER TO
R88 (58h) DC Servo Readback	9:8	DCS_CAL_COMPLETE [1:0]	00	DC Servo Complete status 0 = DAC Write or Start-Up DC Servo mode not completed. 1 = DAC Write or Start-Up DC Servo mode complete. Bit [1] = HPOUT1R Bit [0] = HPOUT1L	
	5:4	DCS_DAC_WR_COMPLETE [1:0]	00	DC Servo DAC Write status 0 = DAC Write DC Servo mode not completed. 1 = DAC Write DC Servo mode complete. Bit [1] = HPOUT1R Bit [0] = HPOUT1L	
	1:0	DCS_STARTUP_COMPLETE [1:0]	00	DC Servo Start-Up status 0 = Start-Up DC Servo mode not completed. 1 = Start-Up DC Servo mode complete. Bit [1] = HPOUT1R Bit [0] = HPOUT1L	

Register 58h DC Servo Readback

REGISTER ADDRESS	BIT	LABEL	DEFAULT	DESCRIPTION	REFER TO
R96 (60h) Analogue HP (1)	7	HPOUT1L_RMV_SHORT	0	Removes HPOUT1L short 0 = HPOUT1L short enabled 1 = HPOUT1L short removed For normal operation, this bit should be set as the final step of the HPOUT1L Enable sequence.	
	6	HPOUT1L_OUT_P	0	Enables HPOUT1L output stage 0 = Disabled 1 = Enabled For normal operation, this bit should be set to 1 after the DC offset cancellation has been scheduled.	

REGISTER ADDRESS	BIT	LABEL	DEFAULT	DESCRIPTION	REFER TO
	5	HPOUT1L_DLY	0	Enables HPOUT1L intermediate stage 0 = Disabled 1 = Enabled For normal operation, this bit should be set to 1 after the output signal path has been configured, and before DC offset cancellation is scheduled. This bit should be set with at least 20us delay after HPOUT1L_ENA.	
	3	HPOUT1R_RMV_SHORT	0	Removes HPOUT1R short 0 = HPOUT1R short enabled 1 = HPOUT1R short removed For normal operation, this bit should be set as the final step of the HPOUT1R Enable sequence.	
	2	HPOUT1R_OUTP	0	Enables HPOUT1R output stage 0 = Disabled 1 = Enabled For normal operation, this bit should be set to 1 after the DC offset cancellation has been scheduled.	
	1	HPOUT1R_DLY	0	Enables HPOUT1R intermediate stage 0 = Disabled 1 = Enabled For normal operation, this bit should be set to 1 after the output signal path has been configured, and before DC offset cancellation is scheduled. This bit should be set with at least 20us delay after HPOUT1R_ENA.	

Register 60h Analogue HP (1)

REGISTER ADDRESS	BIT	LABEL	DEFAULT	DESCRIPTION	REFER TO
R208 (D0h) Mic Detect 1	15:12	MICD_BIAS_STARTTIME [3:0]	0101	Mic Detect Bias Startup Delay (If MICBIAS2 is not enabled already, this field selects the delay time allowed for MICBIAS2 to startup prior to performing the MICDET function.) 0000 = 0ms (continuous) 0001 = 0.25ms 0010 = 0.5ms 0011 = 1ms 0100 = 2ms 0101 = 4ms 0110 = 8ms 0111 = 16ms 1000 = 32ms 1001 = 64ms 1010 = 128ms 1011 = 256ms 1100 to 1111 = 512ms	
	11:8	MICD_RATE [3:0]	0110	Mic Detect Rate (Selects the delay between successive Mic Detect measurements.) 0000 = 0ms (continuous) 0001 = 0.25ms 0010 = 0.5ms 0011 = 1ms 0100 = 2ms 0101 = 4ms	

REGISTER ADDRESS	BIT	LABEL	DEFAULT	DESCRIPTION	REFER TO
				0110 = 8ms 0111 = 16ms 1000 = 32ms 1001 = 64ms 1010 = 128ms 1011 = 256ms 1100 to 1111 = 512ms	
	1	MICD_DBTIME	0	Mic Detect De-bounce 0 = 2 measurements 1 = 4 measurements	
	0	MICD_ENA	0	Mic Detect Enable 0 = Disabled 1 = Enabled	

Register D0h Mic Detect 1

REGISTER ADDRESS	BIT	LABEL	DEFAULT	DESCRIPTION	REFER TO
R209 (D1h) Mic Detect 2	7:0	MICD_LVL_SEL [7:0]	0111_1111	Mic Detect Level Select (enables Mic Detection in specific impedance ranges) [7] = Not used - must be set to 0 [6] = Enable >475 ohm detection [5] = Enable 326 ohm detection [4] = Enable 152 ohm detection [3] = Enable 77 ohm detection [2] = Enable 47.6 ohm detection [1] = Enable 29.4 ohm detection [0] = Enable 14 ohm detection Note that the impedance values quoted assume that a microphone (475ohm-30kohm) is also present on the MICDET pin.	

Register D1h Mic Detect 2

REGISTER ADDRESS	BIT	LABEL	DEFAULT	DESCRIPTION	REFER TO
R210 (D2h) Mic Detect 3	10:2	MICD_LVL [8:0]	0_0000_00 00	Mic Detect Level (indicates the measured impedance) [8] = Not used [7] = >475 ohm, <30k ohm [6] = 326 ohm [5] = 152 ohm [4] = 77 ohm [3] = 47.6 ohm [2] = 29.4 ohm [1] = 14 ohm [0] = <2 ohm Note that the impedance values quoted assume that a microphone (475ohm-30kohm) is also present on the MICDET pin.	
	1	MICD_VALID	0	Mic Detect Data Valid 0 = Not Valid 1 = Valid	

REGISTER ADDRESS	BIT	LABEL	DEFAULT	DESCRIPTION	REFER TO
	0	MICD_STS	0	Mic Detect Status 0 = No Mic Accessory present (impedance is >30k ohm) 1 = Mic Accessory is present (impedance is <30k ohm)	

Register D2h Mic Detect 3

REGISTER ADDRESS	BIT	LABEL	DEFAULT	DESCRIPTION	REFER TO
R256 (0100h) Chip Revision	3:0	CHIP_REV [3:0]		Chip revision	

Register 0100h Chip Revision

REGISTER ADDRESS	BIT	LABEL	DEFAULT	DESCRIPTION	REFER TO
R257 (0101h) Control Interface	2	AUTO_INC	1	Enables address auto-increment 0 = Disabled 1 = Enabled	

Register 0101h Control Interface

REGISTER ADDRESS	BIT	LABEL	DEFAULT	DESCRIPTION	REFER TO
R272 (0110h) Write Sequencer Ctrl (1)	15	WSEQ_ENA	0	Write Sequencer Enable. 0 = Disabled 1 = Enabled	
	9	WSEQ_ABORT	0	Writing a 1 to this bit aborts the current sequence and returns control of the device back to the serial control interface.	
	8	WSEQ_START	0	Writing a 1 to this bit starts the write sequencer at the index location selected by WSEQ_START_INDEX. The sequence continues until it reaches an "End of sequence" flag. At the end of the sequence, this bit will be reset by the Write Sequencer.	
	6:0	WSEQ_START_INDEX [6:0]	000_0000	Sequence Start Index. This field determines the memory location of the first command in the selected sequence. There are 127 Write Sequencer RAM addresses: 00h = WSEQ_ADDR0 (R12288) 01h = WSEQ_ADDR1 (R12292) 02h = WSEQ_ADDR2 (R12296) 7Fh = WSEQ_ADDR127 (R12796)	

Register 0110h Write Sequencer Ctrl (1)

REGISTER ADDRESS	BIT	LABEL	DEFAULT	DESCRIPTION	REFER TO
R273 (0111h) Write Sequencer Ctrl (2)	8	WSEQ_BUSY	0	Sequencer Busy flag (Read Only). 0 = Sequencer idle 1 = Sequencer busy Note: it is not possible to write to control registers via the control interface while the Sequencer is Busy.	

REGISTER ADDRESS	BIT	LABEL	DEFAULT	DESCRIPTION	REFER TO
	6:0	WSEQ_CURRE NT_INDEX [6:0]	000_0000	Sequence Current Index. This indicates the memory location of the most recently accessed command in the write sequencer memory. Coding is the same as WSEQ_START_INDEX.	

Register 0111h Write Sequencer Ctrl (2)

REGISTER ADDRESS	BIT	LABEL	DEFAULT	DESCRIPTION	REFER TO
R512 (0200h) AIF1 Clocking (1)	4:3	AIF1CLK_SRC [1:0]	00	AIF1CLK Source Select 00 = MCLK1 01 = MCLK2 10 = FLL1 11 = FLL2	
	2	AIF1CLK_INV	0	AIF1CLK Invert 0 = AIF1CLK not inverted 1 = AIF1CLK inverted	
	1	AIF1CLK_DIV	0	AIF1CLK Divider 0 = AIF1CLK 1 = AIF1CLK / 2	
	0	AIF1CLK_ENA	0	AIF1CLK Enable 0 = Disabled 1 = Enabled	

Register 0200h AIF1 Clocking (1)

REGISTER ADDRESS	BIT	LABEL	DEFAULT	DESCRIPTION	REFER TO
R513 (0201h) AIF1 Clocking (2)	5:3	AIF1DAC_DIV [2:0]	000	Selects the AIF1 input path sample rate relative to the AIF1 output path sample rate. This field should only be changed from default in modes where the AIF1 input path sample rate is slower than the AIF1 output path sample rate. 000 = Divide by 1 001 = Divide by 1.5 010 = Divide by 2 011 = Divide by 3 100 = Divide by 4 101 = Divide by 5.5 110 = Divide by 6 111 = Reserved	
	2:0	AIF1ADC_DIV [2:0]	000	Selects the AIF1 output path sample rate relative to the AIF1 input path sample rate. This field should only be changed from default in modes where the AIF1 output path sample rate is slower than the AIF1 input path sample rate. 000 = Divide by 1 001 = Divide by 1.5 010 = Divide by 2 011 = Divide by 3 100 = Divide by 4 101 = Divide by 5.5 110 = Divide by 6 111 = Reserved	

Register 0201h AIF1 Clocking (2)

REGISTER ADDRESS	BIT	LABEL	DEFAULT	DESCRIPTION	REFER TO
R516 (0204h) AIF2 Clocking (1)	4:3	AIF2CLK_SRC [1:0]	00	AIF2CLK Source Select 00 = MCLK1 01 = MCLK2 10 = FLL1 11 = FLL2	
	2	AIF2CLK_INV	0	AIF2CLK Invert 0 = AIF2CLK not inverted 1 = AIF2CLK inverted	
	1	AIF2CLK_DIV	0	AIF2CLK Divider 0 = AIF2CLK 1 = AIF2CLK / 2	
	0	AIF2CLK_ENA	0	AIF2CLK Enable 0 = Disabled 1 = Enabled	

Register 0204h AIF2 Clocking (1)

REGISTER ADDRESS	BIT	LABEL	DEFAULT	DESCRIPTION	REFER TO
R517 (0205h) AIF2 Clocking (2)	5:3	AIF2DAC_DIV [2:0]	000	Selects the AIF2 input path sample rate relative to the AIF2 output path sample rate. This field should only be changed from default in modes where the AIF2 input path sample rate is slower than the AIF2 output path sample rate. 000 = Divide by 1 001 = Divide by 1.5 010 = Divide by 2 011 = Divide by 3 100 = Divide by 4 101 = Divide by 5.5 110 = Divide by 6 111 = Reserved	
	2:0	AIF2ADC_DIV [2:0]	000	Selects the AIF2 output path sample rate relative to the AIF2 input path sample rate. This field should only be changed from default in modes where the AIF2 output path sample rate is slower than the AIF2 input path sample rate. 000 = Divide by 1 001 = Divide by 1.5 010 = Divide by 2 011 = Divide by 3 100 = Divide by 4 101 = Divide by 5.5 110 = Divide by 6 111 = Reserved	

Register 0205h AIF2 Clocking (2)

REGISTER ADDRESS	BIT	LABEL	DEFAULT	DESCRIPTION	REFER TO
R520 (0208h) Clocking (1)	14	DSP2CLK_ENA	0	MBC Processor Clock Enable 0 = Disabled 1 = Enabled	
	4	TOCLK_ENA	0	Slow Clock (TOCLK) Enable	

REGISTER ADDRESS	BIT	LABEL	DEFAULT	DESCRIPTION	REFER TO
				0 = Disabled 1 = Enabled This clock is required for zero-cross timeout.	
	3	AIF1DSPCLK_ENA	0	AIF1 Processing Clock Enable 0 = Disabled 1 = Enabled	
	2	AIF2DSPCLK_ENA	0	AIF2 Processing Clock Enable 0 = Disabled 1 = Enabled	
	1	SYSDSPCLK_ENA	0	Digital Mixing Processor Clock Enable 0 = Disabled 1 = Enabled	
	0	SYSCLK_SRC	0	SYSCLK Source Select 0 = AIF1CLK 1 = AIF2CLK	

Register 0208h Clocking (1)

REGISTER ADDRESS	BIT	LABEL	DEFAULT	DESCRIPTION	REFER TO
R521 (0209h) Clocking (2)	10:8	TOCLK_DIV [2:0]	000	Slow Clock (TOCLK) Divider (Sets TOCLK rate relative to 256kHz.) 000 = Divide by 256 (1kHz) 001 = Divide by 512 (500Hz) 010 = Divide by 1024 (250Hz) 011 = Divide by 2048 (125Hz) 100 = Divide by 4096 (62.5Hz) 101 = Divide by 8192 (31.2Hz) 110 = Divide by 16384 (15.6Hz) 111 = Divide by 32768 (7.8Hz)	
	6:4	DBCLK_DIV [2:0]	000	De-bounce Clock (DBCLK) Divider (Sets DBCLK rate relative to 256kHz.) 000 = Divide by 256 (1kHz) 001 = Divide by 2048 (125Hz) 010 = Divide by 4096 (62.5Hz) 011 = Divide by 8192 (31.2Hz) 100 = Divide by 16384 (15.6Hz) 101 = Divide by 32768 (7.8Hz) 110 = Divide by 65536 (3.9Hz) 111 = Divide by 131072 (1.95Hz)	
	2:0	OPCLK_DIV [2:0]	000	GPIO Output Clock (OPCLK) Divider 000 = SYSCLK 001 = SYSCLK / 2 010 = SYSCLK / 3 011 = SYSCLK / 4 100 = SYSCLK / 6 101 = SYSCLK / 8 110 = SYSCLK / 12 111 = SYSCLK / 16	

Register 0209h Clocking (2)

REGISTER ADDRESS	BIT	LABEL	DEFAULT	DESCRIPTION	REFER TO
R528 (0210h) AIF1 Rate	7:4	AIF1_SR [3:0]	1000	Selects the AIF1 Sample Rate (fs) 0000 = 8kHz 0001 = 11.025kHz 0010 = 12kHz 0011 = 16kHz 0100 = 22.05kHz 0101 = 24kHz 0110 = 32kHz 0111 = 44.1kHz 1000 = 48kHz 1001 = 88.2kHz 1010 = 96kHz All other codes = Reserved Note that 88.2kHz and 96kHz modes are supported for AIF1 input (DAC playback) only.	
	3:0	AIF1CLK_RATE [3:0]	0011	Selects the AIF1CLK / fs ratio 0000 = Reserved 0001 = 128 0010 = 192 0011 = 256 0100 = 384 0101 = 512 0110 = 768 0111 = 1024 1000 = 1408 1001 = 1536 All other codes = Reserved	

Register 0210h AIF1 Rate

REGISTER ADDRESS	BIT	LABEL	DEFAULT	DESCRIPTION	REFER TO
R529 (0211h) AIF2 Rate	7:4	AIF2_SR [3:0]	1000	Selects the AIF2 Sample Rate (fs) 0000 = 8kHz 0001 = 11.025kHz 0010 = 12kHz 0011 = 16kHz 0100 = 22.05kHz 0101 = 24kHz 0110 = 32kHz 0111 = 44.1kHz 1000 = 48kHz 1001 = 88.2kHz 1010 = 96kHz All other codes = Reserved Note that 88.2kHz and 96kHz modes are supported for AIF2 input (DAC playback) only.	
	3:0	AIF2CLK_RATE [3:0]	0011	Selects the AIF2CLK / fs ratio 0000 = Reserved 0001 = 128 0010 = 192 0011 = 256 0100 = 384 0101 = 512	

REGISTER ADDRESS	BIT	LABEL	DEFAULT	DESCRIPTION	REFER TO
				0110 = 768 0111 = 1024 1000 = 1408 1001 = 1536 All other codes = Reserved	

Register 0211h AIF2 Rate

REGISTER ADDRESS	BIT	LABEL	DEFAULT	DESCRIPTION	REFER TO
R530 (0212h) Rate Status	3:0	SR_ERROR [3:0]	0000	Sample Rate Configuration status Indicates an error with the register settings related to sample rate configuration 0000 = No errors 0001 = Invalid sample rate 0010 = Invalid AIF divide 0011 = ADC and DAC divides both set in an interface 0100 = Invalid combination of AIF divides and sample-rate 0101 = Invalid set of enables for 96kHz mode 0110 = Invalid SYSCLK rate (derived from AIF1CLK_RATE or AIF2CLK_RATE) 0111 = Mixed ADC and DAC rates in SYSCLK AIF when AIFs are asynchronous 1000 = Invalid combination of sample rates when both AIFs are from the same clock source 1001 = Invalid combination of mixed ADC/DAC AIFs when both from the same clock source 1010 = AIF1DAC2 (Timeslot 1) ports enabled when SRCs connected to AIF1	

Register 0212h Rate Status

REGISTER ADDRESS	BIT	LABEL	DEFAULT	DESCRIPTION	REFER TO
R544 (0220h) FLL1 Control (1)	1	FLL1_OSC_EN A	0	FLL1 Oscillator enable 0 = Disabled 1 = Enabled (Note that this field is required for free-running FLL1 modes only)	
	0	FLL1_ENA	0	FLL1 Enable 0 = Disabled 1 = Enabled This should be set as the final step of the FLL1 enable sequence, ie. after the other FLL registers have been configured.	

Register 0220h FLL1 Control (1)

REGISTER ADDRESS	BIT	LABEL	DEFAULT	DESCRIPTION	REFER TO
R545 (0221h) FLL1 Control (2)	13:8	FLL1_OUTDIV [5:0]	00_0000	FLL1 FOUT clock divider 000000 = Reserved 000001 = Reserved 000010 = Reserved 000011 = 4 000100 = 5 000101 = 6	

REGISTER ADDRESS	BIT	LABEL	DEFAULT	DESCRIPTION	REFER TO
				... 111110 = 63 111111 = 64 (FOUT = FVCO / FLL1_OUTDIV)	
	2:0	FLL1_FRATIO [2:0]	000	FLL1 FVCO clock divider 000 = 1 001 = 2 010 = 4 011 = 8 1XX = 16	

Register 0221h FLL1 Control (2)

REGISTER ADDRESS	BIT	LABEL	DEFAULT	DESCRIPTION	REFER TO
R546 (0222h) FLL1 Control (3)	15:0	FLL1_K [15:0]	0000_0000 _0000_000 0	FLL1 Fractional multiply for FREF (MSB = 0.5)	

Register 0222h FLL1 Control (3)

REGISTER ADDRESS	BIT	LABEL	DEFAULT	DESCRIPTION	REFER TO
R547 (0223h) FLL1 Control (4)	14:5	FLL1_N [9:0]	00_0000_0 000	FLL1 Integer multiply for FREF (LSB = 1)	

Register 0223h FLL1 Control (4)

REGISTER ADDRESS	BIT	LABEL	DEFAULT	DESCRIPTION	REFER TO
R548 (0224h) FLL1 Control (5)	15	FLL1_BYP	0	FLL1 Bypass Select 0 = Disabled 1 = Enabled When FLL1_BYP is set, the FLL1 output is derived directly from BCLK1. In this case, FLL1 can be disabled.	
	12:7	FLL1_FRC_NCO_VAL [5:0]	01_1001	FLL1 Forced oscillator value Valid range is 000000 to 111111 0x19h (011001) = 12MHz approx (Note that this field is required for free-running FLL modes only)	
	6	FLL1_FRC_NCO	0	FLL1 Forced control select 0 = Normal 1 = FLL1 oscillator controlled by FLL1_FRC_NCO_VAL (Note that this field is required for free-running FLL modes only)	
	4:3	FLL1_REFCLK_DIV [1:0]	00	FLL1 Clock Reference Divider 00 = MCLK / 1 01 = MCLK / 2 10 = MCLK / 4 11 = MCLK / 8 MCLK (or other input reference) must be divided down to <=13.5MHz.	

REGISTER ADDRESS	BIT	LABEL	DEFAULT	DESCRIPTION	REFER TO
				For lower power operation, the reference clock can be divided down further if desired.	
	1:0	FLL1_REFCLK_SRC [1:0]	00	FLL1 Clock source 00 = MCLK1 01 = MCLK2 10 = LRCLK1 11 = BCLK1	

Register 0224h FLL1 Control (5)

REGISTER ADDRESS	BIT	LABEL	DEFAULT	DESCRIPTION	REFER TO
R550 (0226h) FLL1 EFS 1	15:0	FLL1_LAMBDA [15:0]	0000_0000 _0000_000 0	FLL Fractional multiply for FREF This field sets the denominator (dividing) part of the FLL1_THETA / FLL1_LAMBDA ratio. Coded as LSB = 1.	

Register 0226h FLL1 EFS 1

REGISTER ADDRESS	BIT	LABEL	DEFAULT	DESCRIPTION	REFER TO
R550 (0226h) FLL1 EFS 1	2	Reserved	1	Reserved - do not change	
	1	Reserved	1	Reserved - do not change	
	0	FLL1_EFS_ENA	0	FLL Fractional Mode EFS enable 0 = Integer Mode 1 = Fractional Mode This bit should be set to 1 when FLL1_THETA > 0.	

Register 0227h FLL1 EFS 2

REGISTER ADDRESS	BIT	LABEL	DEFAULT	DESCRIPTION	REFER TO
R576 (0240h) FLL2 Control (1)	1	FLL2_OSC_EN A	0	FLL2 Oscillator enable 0 = Disabled 1 = Enabled (Note that this field is required for free-running FLL2 modes only)	
	0	FLL2_ENA	0	FLL2 Enable 0 = Disabled 1 = Enabled This should be set as the final step of the FLL2 enable sequence, ie. after the other FLL registers have been configured.	

Register 0240h FLL2 Control (1)

REGISTER ADDRESS	BIT	LABEL	DEFAULT	DESCRIPTION	REFER TO
R577 (0241h) FLL2 Control (2)	13:8	FLL2_OUTDIV [5:0]	00_0000	FLL2 FOUT clock divider 000000 = Reserved 000001 = Reserved 000010 = Reserved 000011 = 4 000100 = 5 000101 = 6 ... 111110 = 63 111111 = 64 (FOUT = FVCO / FLL2_OUTDIV)	
	2:0	FLL2_FRATIO [2:0]	000	FLL2 FVCO clock divider 000 = 1 001 = 2 010 = 4 011 = 8 1XX = 16	

Register 0241h FLL2 Control (2)

REGISTER ADDRESS	BIT	LABEL	DEFAULT	DESCRIPTION	REFER TO
R578 (0242h) FLL2 Control (3)	15:0	FLL2_K [15:0]	0000_0000 _0000_000 0	FLL2 Fractional multiply for FREF (MSB = 0.5)	

Register 0242h FLL2 Control (3)

REGISTER ADDRESS	BIT	LABEL	DEFAULT	DESCRIPTION	REFER TO
R579 (0243h) FLL2 Control (4)	14:5	FLL2_N [9:0]	00_0000_0 000	FLL2 Integer multiply for FREF (LSB = 1)	

Register 0243h FLL2 Control (4)

REGISTER ADDRESS	BIT	LABEL	DEFAULT	DESCRIPTION	REFER TO
R580 (0244h) FLL2 Control (5)	15	FLL2_BYP	0	FLL2 Bypass Select 0 = Disabled 1 = Enabled When FLL2_BYP is set, the FLL2 output is derived directly from BCLK2. In this case, FLL2 can be disabled.	
	12:7	FLL2_FRC_NC O_VAL [5:0]	01_1001	FLL2 Forced oscillator value Valid range is 000000 to 111111 0x19h (011001) = 12MHz approx (Note that this field is required for free-running FLL modes only)	
	6	FLL2_FRC_NC O	0	FLL2 Forced control select 0 = Normal 1 = FLL2 oscillator controlled by FLL2_FRC_NCO_VAL (Note that this field is required for free-running FLL modes only)	

REGISTER ADDRESS	BIT	LABEL	DEFAULT	DESCRIPTION	REFER TO
	4:3	FLL2_REFCLK_DIV [1:0]	00	FLL2 Clock Reference Divider 00 = MCLK / 1 01 = MCLK / 2 10 = MCLK / 4 11 = MCLK / 8 MCLK (or other input reference) must be divided down to <=13.5MHz. For lower power operation, the reference clock can be divided down further if desired.	
	1:0	FLL2_REFCLK_SRC [1:0]	00	FLL2 Clock source 00 = MCLK1 01 = MCLK2 10 = LRCLK2 11 = BCLK2	

Register 0244h FLL2 Control (5)

REGISTER ADDRESS	BIT	LABEL	DEFAULT	DESCRIPTION	REFER TO
R582 (0246h) FLL2 EFS 1	15:0	FLL2_LAMBDA [15:0]	0000_0000 _0000_0000 0	FLL Fractional multiply for FREF This field sets the denominator (dividing) part of the FLL2_THETA / FLL2_LAMBDA ratio. Coded as LSB = 1.	

Register 0246h FLL2 EFS 1

REGISTER ADDRESS	BIT	LABEL	DEFAULT	DESCRIPTION	REFER TO
R583 (0247h) FLL2 EFS 2	2	Reserved	1	Reserved - do not change	
	1	Reserved	1	Reserved - do not change	
	0	FLL2_EFS_ENA	0	FLL Fractional Mode EFS enable 0 = Integer Mode 1 = Fractional Mode This bit should be set to 1 when FLL2_THETA > 0.	

Register 0247h FLL2 EFS 2

REGISTER ADDRESS	BIT	LABEL	DEFAULT	DESCRIPTION	REFER TO
R768 (0300h) AIF1 Control (1)	15	AIF1ADCL_SRC	0	AIF1 Left Digital Audio interface source 0 = Left ADC data is output on left channel 1 = Right ADC data is output on left channel	
	14	AIF1ADCR_SRC	1	AIF1 Right Digital Audio interface source 0 = Left ADC data is output on right channel 1 = Right ADC data is output on right channel	
	13	AIF1ADC_TDM	0	AIF1 transmit (ADC) TDM Control 0 = ADCDAT1 drives logic '0' when not transmitting data 1 = ADCDAT1 is tri-stated when not transmitting data	
	8	AIF1_BCLK_INV	0	BCLK1 Invert 0 = BCLK1 not inverted 1 = BCLK1 inverted Note that AIF1_BCLK_INV selects the BCLK1 polarity in	

REGISTER ADDRESS	BIT	LABEL	DEFAULT	DESCRIPTION	REFER TO
				Master mode and in Slave mode.	
	6:5	AIF1_WL [1:0]	10	AIF1 Digital Audio Interface Word Length 00 = 16 bits 01 = 20 bits 10 = 24 bits 11 = 32 bits Note - 8-bit modes can be selected using the "Companding" control bits.	
	4:3	AIF1_FMT [1:0]	10	AIF1 Digital Audio Interface Format 00 = Right justified 01 = Left justified 10 = I2S Format 11 = DSP Mode	

Register 0300h AIF1 Control (1)

REGISTER ADDRESS	BIT	LABEL	DEFAULT	DESCRIPTION	REFER TO
R769 (0301h) AIF1 Control (2)	15	AIF1DACL_SRC	0	AIF1 Left Receive Data Source Select 0 = Left DAC receives left interface data 1 = Left DAC receives right interface data	
	14	AIF1DACR_SRC	1	AIF1 Right Receive Data Source Select 0 = Right DAC receives left interface data 1 = Right DAC receives right interface data	
	11:10	AIF1DAC_BOOST [1:0]	00	AIF1 Input Path Boost 00 = 0dB 01 = +6dB (input must not exceed -6dBFS) 10 = +12dB (input must not exceed -12dBFS) 11 = +18dB (input must not exceed -18dBFS)	
	8	AIF1_MONO	0	AIF1 DSP Mono Mode 0 = Disabled 1 = Enabled Note that Mono Mode is only supported when AIF1_FMT = 11.	
	4	AIF1DAC_COMP	0	AIF1 Receive Companding Enable 0 = Disabled 1 = Enabled	
	3	AIF1DAC_COMP_MODE	0	AIF1 Receive Companding Type 0 = μ -law 1 = A-law	
	2	AIF1ADC_COMP	0	AIF1 Transmit Companding Enable 0 = Disabled 1 = Enabled	
	1	AIF1ADC_COMP_MODE	0	AIF1 Transmit Companding Type 0 = μ -law 1 = A-law	
	0	AIF1_LOOPBACK	0	AIF1 Digital Loopback Function 0 = No loopback 1 = Loopback enabled (ADCDAT1 data output is directly input to DACDAT1 data input).	

Register 0301h AIF1 Control (2)

REGISTER ADDRESS	BIT	LABEL	DEFAULT	DESCRIPTION	REFER TO
R770 (0302h) AIF1 Master/Slave	15	AIF1_TRI	0	AIF1 Audio Interface tri-state 0 = AIF1 pins operate normally 1 = Tri-state all AIF1 interface pins Note that the GPIO1 pin is controlled by this register only when configured as ADCLRCLK1.	
	14	AIF1_MSTR	0	AIF1 Audio Interface Master Mode Select 0 = Slave mode 1 = Master mode	
	13	AIF1_CLK_FRC	0	Forces BCLK1, LRCLK1 and ADCLRCLK1 to be enabled when all AIF1 audio channels are disabled. 0 = Normal 1 = BCLK1, LRCLK1 and ADCLRCLK1 always enabled in Master mode	
	12	AIF1_LRCLK_FRC	0	Forces LRCLK1 and ADCLRCLK1 to be enabled when all AIF1 audio channels are disabled. 0 = Normal 1 = LRCLK1 and ADCLRCLK1 always enabled in Master mode	

Register 0302h AIF1 Master/Slave

REGISTER ADDRESS	BIT	LABEL	DEFAULT	DESCRIPTION	REFER TO
R771 (0303h) AIF1 BCLK	8:4	AIF1_BCLK_DIV [4:0]	0_0100	BCLK1 Rate 00000 = AIF1CLK 00001 = AIF1CLK / 1.5 00010 = AIF1CLK / 2 00011 = AIF1CLK / 3 00100 = AIF1CLK / 4 00101 = AIF1CLK / 5 00110 = AIF1CLK / 6 00111 = AIF1CLK / 8 01000 = AIF1CLK / 11 01001 = AIF1CLK / 12 01010 = AIF1CLK / 16 01011 = AIF1CLK / 22 01100 = AIF1CLK / 24 01101 = AIF1CLK / 32 01110 = AIF1CLK / 44 01111 = AIF1CLK / 48 10000 = AIF1CLK / 64 10001 = AIF1CLK / 88 10010 = AIF1CLK / 96 10011 = AIF1CLK / 128 10100 = AIF1CLK / 176 10101 = AIF1CLK / 192 10110 - 11111 = Reserved	

Register 0303h AIF1 BCLK

REGISTER ADDRESS	BIT	LABEL	DEFAULT	DESCRIPTION	REFER TO
R772 (0304h) AIF1ADC LRCLK	12	AIF1ADC_LRCLK_INV	0	Right, left and I2S modes – ADCLRCLK1 polarity 0 = normal ADCLRCLK1 polarity 1 = invert ADCLRCLK1 polarity Note that AIF1ADC_LRCLK_INV selects the ADCLRCLK1 polarity in Master mode and in Slave mode. DSP Mode – mode A/B select 0 = MSB is available on 2nd BCLK1 rising edge after ADCLRCLK1 rising edge (mode A) 1 = MSB is available on 1st BCLK1 rising edge after ADCLRCLK1 rising edge (mode B)	
	11	AIF1ADC_LRCLK_DIR	0	Allows ADCLRCLK1 to be enabled in Slave mode 0 = Normal 1 = ADCLRCLK1 enabled in Slave mode	
	10:0	AIF1ADC_RATE [10:0]	000_0100_0000	ADCLRCLK1 Rate ADCLRCLK1 clock output = BCLK1 / AIF1ADC_RATE Integer (LSB = 1) Valid from 8..2047	

Register 0304h AIF1ADC LRCLK

REGISTER ADDRESS	BIT	LABEL	DEFAULT	DESCRIPTION	REFER TO
R773 (0305h) AIF1DAC LRCLK	12	AIF1DAC_LRCLK_INV	0	Right, left and I2S modes – LRCLK1 polarity 0 = normal LRCLK1 polarity 1 = invert LRCLK1 polarity Note that AIF1DAC_LRCLK_INV selects the LRCLK1 polarity in Master mode and in Slave mode. DSP Mode – mode A/B select 0 = MSB is available on 2nd BCLK1 rising edge after LRCLK1 rising edge (mode A) 1 = MSB is available on 1st BCLK1 rising edge after LRCLK1 rising edge (mode B)	
	11	AIF1DAC_LRCLK_DIR	0	Allows LRCLK1 to be enabled in Slave mode 0 = Normal 1 = LRCLK1 enabled in Slave mode	
	10:0	AIF1DAC_RATE [10:0]	000_0100_0000	LRCLK1 Rate LRCLK1 clock output = BCLK1 / AIF1DAC_RATE Integer (LSB = 1) Valid from 8..2047	

Register 0305h AIF1DAC LRCLK

REGISTER ADDRESS	BIT	LABEL	DEFAULT	DESCRIPTION	REFER TO
R774 (0306h) AIF1DAC Data	1	AIF1DACL_DAT _INV	0	AIF1 Left Receive Data Invert 0 = Not inverted 1 = Inverted	
	0	AIF1DACR_DAT _INV	0	AIF1 Right Receive Data Invert 0 = Not inverted 1 = Inverted	

Register 0306h AIF1DAC Data

REGISTER ADDRESS	BIT	LABEL	DEFAULT	DESCRIPTION	REFER TO
R775 (0307h) AIF1ADC Data	1	AIF1ADCL_DAT _INV	0	AIF1 Left Transmit Data Invert 0 = Not inverted 1 = Inverted	
	0	AIF1ADCR_DAT _INV	0	AIF1 Right Transmit Data Invert 0 = Not inverted 1 = Inverted	

Register 0307h AIF1ADC Data

REGISTER ADDRESS	BIT	LABEL	DEFAULT	DESCRIPTION	REFER TO
R784 (0310h) AIF2 Control (1)	15	AIF2ADCL_SRC	0	AIF2 Left Digital Audio interface source 0 = Left ADC data is output on left channel 1 = Right ADC data is output on left channel	
	14	AIF2ADCR_SRC	1	AIF2 Right Digital Audio interface source 0 = Left ADC data is output on right channel 1 = Right ADC data is output on right channel	
	13	AIF2ADC_TDM	0	AIF2 transmit (ADC) TDM Enable 0 = Normal ADCDAT2 operation 1 = TDM enabled on ADCDAT2	
	12	AIF2ADC_TDM_CHAN	0	AIF2 transmit (ADC) TDM Slot Select 0 = Slot 0 1 = Slot 1	
	8	AIF2_BCLK_INV	0	BCLK2 Invert 0 = BCLK2 not inverted 1 = BCLK2 inverted Note that AIF2_BCLK_INV selects the BCLK2 polarity in Master mode and in Slave mode.	
	6:5	AIF2_WL [1:0]	10	AIF2 Digital Audio Interface Word Length 00 = 16 bits 01 = 20 bits 10 = 24 bits 11 = 32 bits Note - 8-bit modes can be selected using the "Companding" control bits.	
	4:3	AIF2_FMT [1:0]	10	AIF2 Digital Audio Interface Format 00 = Right justified 01 = Left justified 10 = I2S Format 11 = DSP Mode	
	1	AIF2TXL_ENA	1	Enable AIF2DAC (Left) input path 0 = Disabled	

REGISTER ADDRESS	BIT	LABEL	DEFAULT	DESCRIPTION	REFER TO
				1 = Enabled This bit must be set for AIF2 output of the AIF2ADC (Left) signal. For AIF3 output only, this bit can be set to 0.	
	0	AIF2TXR_ENA	1	Enable AIF2DAC (Right) input path 0 = Disabled 1 = Enabled This bit must be set for AIF2 output of the AIF2ADC (Left) signal. For AIF3 output only, this bit can be set to 0.	

Register 0310h AIF2 Control (1)

REGISTER ADDRESS	BIT	LABEL	DEFAULT	DESCRIPTION	REFER TO
R785 (0311h) AIF2 Control (2)	15	AIF2DACL_SRC	0	AIF2 Left Receive Data Source Select 0 = Left DAC receives left interface data 1 = Left DAC receives right interface data	
	14	AIF2DACR_SRC	1	AIF2 Right Receive Data Source Select 0 = Right DAC receives left interface data 1 = Right DAC receives right interface data	
	13	AIF2DAC_TDM	0	AIF2 receive (DAC) TDM Enable 0 = Normal DACDAT2 operation 1 = TDM enabled on DACDAT2	
	12	AIF2DAC_TDM_CHAN	0	AIF2 receive (DAC) TDM Slot Select 0 = Slot 0 1 = Slot 1	
	11:10	AIF2DAC_BOOST [1:0]	00	AIF2 Input Path Boost 00 = 0dB 01 = +6dB (input must not exceed -6dBFS) 10 = +12dB (input must not exceed -12dBFS) 11 = +18dB (input must not exceed -18dBFS)	
	8	AIF2_MONO	0	AIF2 DSP Mono Mode 0 = Disabled 1 = Enabled Note that Mono Mode is only supported when AIF2_FMT = 11.	
	4	AIF2DAC_COMP	0	AIF2 Receive Companding Enable 0 = Disabled 1 = Enabled	
	3	AIF2DAC_COMP_MODE	0	AIF2 Receive Companding Type 0 = μ -law 1 = A-law	
	2	AIF2ADC_COMP	0	AIF2 Transmit Companding Enable 0 = Disabled 1 = Enabled	
	1	AIF2ADC_COMP_MODE	0	AIF2 Transmit Companding Type 0 = μ -law 1 = A-law	
	0	AIF2_LOOPBACK	0	AIF2 Digital Loopback Function 0 = No loopback 1 = Loopback enabled (ADCCDAT2 data output is directly input to DACDAT2 data input).	

Register 0311h AIF2 Control (2)

REGISTER ADDRESS	BIT	LABEL	DEFAULT	DESCRIPTION	REFER TO
R786 (0312h) AIF2 Master/Slave	15	AIF2_TRI	0	AIF2 Audio Interface tri-state 0 = AIF2 pins operate normally 1 = Tri-state all AIF2 interface pins Note that pins not configured as AIF2 functions are not affected by this register.	
	14	AIF2_MSTR	0	AIF2 Audio Interface Master Mode Select 0 = Slave mode 1 = Master mode	
	13	AIF2_CLK_FRC	0	Forces BCLK2, LRCLK2 and ADCLRCLK2 to be enabled when all AIF2 audio channels are disabled. 0 = Normal 1 = BCLK2, LRCLK2 and ADCLRCLK2 always enabled in Master mode	
	12	AIF2_LRCLK_FRC	0	Forces LRCLK2 and ADCLRCLK2 to be enabled when all AIF2 audio channels are disabled. 0 = Normal 1 = LRCLK2 and ADCLRCLK2 always enabled in Master mode	

Register 0312h AIF2 Master/Slave

REGISTER ADDRESS	BIT	LABEL	DEFAULT	DESCRIPTION	REFER TO
R787 (0313h) AIF2 BCLK	8:4	AIF2_BCLK_DIV [4:0]	0_0100	BCLK2 Rate 00000 = AIF2CLK 00001 = AIF2CLK / 1.5 00010 = AIF2CLK / 2 00011 = AIF2CLK / 3 00100 = AIF2CLK / 4 00101 = AIF2CLK / 5 00110 = AIF2CLK / 6 00111 = AIF2CLK / 8 01000 = AIF2CLK / 11 01001 = AIF2CLK / 12 01010 = AIF2CLK / 16 01011 = AIF2CLK / 22 01100 = AIF2CLK / 24 01101 = AIF2CLK / 32 01110 = AIF2CLK / 44 01111 = AIF2CLK / 48 10000 = AIF2CLK / 64 10001 = AIF2CLK / 88 10010 = AIF2CLK / 96 10011 = AIF2CLK / 128 10100 = AIF2CLK / 176 10101 = AIF2CLK / 192 10110 - 11111 = Reserved	

Register 0313h AIF2 BCLK

REGISTER ADDRESS	BIT	LABEL	DEFAULT	DESCRIPTION	REFER TO
R788 (0314h) AIF2ADC LRCLK	12	AIF2ADC_LRCLK_INV	0	Right, left and I2S modes – ADCLRCLK2 polarity 0 = normal ADCLRCLK2 polarity 1 = invert ADCLRCLK2 polarity Note that AIF2ADC_LRCLK_INV selects the ADCLRCLK2 polarity in Master mode and in Slave mode. DSP Mode – mode A/B select 0 = MSB is available on 2nd BCLK2 rising edge after ADCLRCLK2 rising edge (mode A) 1 = MSB is available on 1st BCLK2 rising edge after ADCLRCLK2 rising edge (mode B)	
	11	AIF2ADC_LRCLK_DIR	0	Allows ADCLRCLK2 to be enabled in Slave mode 0 = Normal 1 = ADCLRCLK2 enabled in Slave mode	
	10:0	AIF2ADC_RATE [10:0]	000_0100_0000	ADCLRCLK2 Rate ADCLRCLK2 clock output = BCLK2 / AIF2ADC_RATE Integer (LSB = 1) Valid from 8..2047	

Register 0314h AIF2ADC LRCLK

REGISTER ADDRESS	BIT	LABEL	DEFAULT	DESCRIPTION	REFER TO
R789 (0315h) AIF2DAC LRCLK	12	AIF2DAC_LRCLK_INV	0	Right, left and I2S modes – LRCLK2 polarity 0 = normal LRCLK2 polarity 1 = invert LRCLK2 polarity Note that AIF2DAC_LRCLK_INV selects the LRCLK2 polarity in Master mode and in Slave mode. DSP Mode – mode A/B select 0 = MSB is available on 2nd BCLK2 rising edge after LRCLK2 rising edge (mode A) 1 = MSB is available on 1st BCLK2 rising edge after LRCLK2 rising edge (mode B)	
	11	AIF2DAC_LRCLK_DIR	0	Allows LRCLK2 to be enabled in Slave mode 0 = Normal 1 = LRCLK2 enabled in Slave mode	
	10:0	AIF2DAC_RATE [10:0]	000_0100_0000	LRCLK2 Rate LRCLK2 clock output = BCLK2 / AIF2DAC_RATE Integer (LSB = 1) Valid from 8..2047	

Register 0315h AIF2DAC LRCLK

REGISTER ADDRESS	BIT	LABEL	DEFAULT	DESCRIPTION	REFER TO
R790 (0316h) AIF2DAC Data	1	AIF2DACL_DAT _INV	0	AIF2 Left Receive Data Invert 0 = Not inverted 1 = Inverted	
	0	AIF2DACR_DAT _INV	0	AIF2 Right Receive Data Invert 0 = Not inverted 1 = Inverted	

Register 0316h AIF2DAC Data

REGISTER ADDRESS	BIT	LABEL	DEFAULT	DESCRIPTION	REFER TO
R791 (0317h) AIF2ADC Data	1	AIF2ADCL_DAT _INV	0	AIF2 Left Transmit Data Invert 0 = Not inverted 1 = Inverted	
	0	AIF2ADCR_DAT _INV	0	AIF2 Right Transmit Data Invert 0 = Not inverted 1 = Inverted	

Register 0317h AIF2ADC Data

REGISTER ADDRESS	BIT	LABEL	DEFAULT	DESCRIPTION	REFER TO
R800 (0320h) AIF3 Control (1)	7	AIF3_LRCLK_IN V	0	Right, left and I ² S modes – LRCLK3 polarity 0 = normal LRCLK3 polarity 1 = invert LRCLK3 polarity DSP Mode – mode A/B select 0 = MSB is available on 2nd BCLK3 rising edge after LRCLK3 rising edge (mode A) 1 = MSB is available on 1st BCLK3 rising edge after LRCLK3 rising edge (mode B)	
	6:5	AIF3_WL [1:0]	10	AIF3 Digital Audio Interface Word Length 00 = 16 bits 01 = 20 bits 10 = 24 bits 11 = 32 bits Note - 8-bit modes can be selected using the “Companding” control bits. Note that this controls the AIF3 Mono PCM interface path only; it does not affect AIF3 inputs/outputs routed to AIF1 or AIF2.	

Register 0320h AIF3 Control (1)

REGISTER ADDRESS	BIT	LABEL	DEFAULT	DESCRIPTION	REFER TO
R801 (0321h) AIF3 Control (2)	11:10	AIF3DAC_BOO ST [1:0]	00	AIF3 Input Path Boost 00 = 0dB 01 = +6dB (input must not exceed -6dBFS) 10 = +12dB (input must not exceed -12dBFS) 11 = +18dB (input must not exceed -18dBFS) Note that this controls the AIF3 Mono PCM interface path only; it does not affect DACDAT3 input to AIF1 or AIF2.	

REGISTER ADDRESS	BIT	LABEL	DEFAULT	DESCRIPTION	REFER TO
	4	AIF3DAC_COMP	0	AIF3 Receive Companding Enable 0 = Disabled 1 = Enabled Note that this controls the AIF3 Mono PCM interface path only; it does not affect DACDAT3 input to AIF1 or AIF2.	
	3	AIF3DAC_COMP_MODE	0	AIF3 Receive Companding Type 0 = μ -law 1 = A-law Note that this controls the AIF3 Mono PCM interface path only; it does not affect DACDAT3 input to AIF1 or AIF2.	
	2	AIF3ADC_COMP	0	AIF3 Transmit Companding Enable 0 = Disabled 1 = Enabled Note that this controls the AIF3 Mono PCM interface path only; it does not affect ADCDAT3 output from AIF1 or AIF2.	
	1	AIF3ADC_COMP_MODE	0	AIF3 Transmit Companding Type 0 = μ -law 1 = A-law Note that this controls the AIF3 Mono PCM interface path only; it does not affect ADCDAT3 output from AIF1 or AIF2.	
	0	AIF3_LOOPBACK	0	AIF3 Digital Loopback Function 0 = No loopback 1 = Loopback enabled (AIF3 Mono PCM data output is directly input to AIF3 Mono PCM data input).	

Register 0321h AIF3 Control (2)

REGISTER ADDRESS	BIT	LABEL	DEFAULT	DESCRIPTION	REFER TO
R802 (0322h) AIF3DAC Data	0	AIF3DAC_DATA_INV	0	AIF3 Receive Data Invert 0 = Not inverted 1 = Inverted Note that this controls the AIF3 Mono PCM interface path only; it does not affect DACDAT3 input to AIF1 or AIF2.	

Register 0322h AIF3DAC Data

REGISTER ADDRESS	BIT	LABEL	DEFAULT	DESCRIPTION	REFER TO
R803 (0323h) AIF3ADC Data	0	AIF3ADC_DATA_INV	0	AIF3 Transmit Data Invert 0 = Not inverted 1 = Inverted Note that this controls the AIF3 Mono PCM interface path only; it does not affect ADCDAT3 output from AIF1 or AIF2.	

Register 0323h AIF3ADC Data

REGISTER ADDRESS	BIT	LABEL	DEFAULT	DESCRIPTION	REFER TO
R1024 (0400h) AIF1 ADC1 Left Volume	8	AIF1ADC1_VU	0	AIF1ADC1 output path (AIF1, Timeslot 0) Volume Update Writing a 1 to this bit will cause the AIF1ADC1L and AIF1ADC1R volume to be updated simultaneously	
	7:0	AIF1ADC1L_VOL [7:0]	1100_0000	AIF1ADC1 (Left) output path (AIF1, Timeslot 0) Digital Volume	

REGISTER ADDRESS	BIT	LABEL	DEFAULT	DESCRIPTION	REFER TO
				00h = MUTE 01h = -71.625dB ... (0.375dB steps) EFh = +17.625dB	

Register 0400h AIF1 ADC1 Left Volume

REGISTER ADDRESS	BIT	LABEL	DEFAULT	DESCRIPTION	REFER TO
R1025 (0401h) AIF1 ADC1 Right Volume	8	AIF1ADC1_VU	0	AIF1ADC1 output path (AIF1, Timeslot 0) Volume Update Writing a 1 to this bit will cause the AIF1ADC1L and AIF1ADC1R volume to be updated simultaneously	
	7:0	AIF1ADC1R_VO L [7:0]	1100_0000	AIF1ADC1 (Right) output path (AIF1, Timeslot 0) Digital Volume 00h = MUTE 01h = -71.625dB ... (0.375dB steps) EFh = +17.625dB	

Register 0401h AIF1 ADC1 Right Volume

REGISTER ADDRESS	BIT	LABEL	DEFAULT	DESCRIPTION	REFER TO
R1026 (0402h) AIF1 DAC1 Left Volume	8	AIF1DAC1_VU	0	AIF1DAC1 input path (AIF1, Timeslot 0) Volume Update Writing a 1 to this bit will cause the AIF1DAC1L and AIF1DAC1R volume to be updated simultaneously	
	7:0	AIF1DAC1L_VO L [7:0]	1100_0000	AIF1DAC1 (Left) input path (AIF1, Timeslot 0) Digital Volume 00h = MUTE 01h = -71.625dB ... (0.375dB steps) C0h = 0dB FFh = 0dB	

Register 0402h AIF1 DAC1 Left Volume

REGISTER ADDRESS	BIT	LABEL	DEFAULT	DESCRIPTION	REFER TO
R1027 (0403h) AIF1 DAC1 Right Volume	8	AIF1DAC1_VU	0	AIF1DAC1 input path (AIF1, Timeslot 0) Volume Update Writing a 1 to this bit will cause the AIF1DAC1L and AIF1DAC1R volume to be updated simultaneously	
	7:0	AIF1DAC1R_VO L [7:0]	1100_0000	AIF1DAC1 (Right) input path (AIF1, Timeslot 0) Digital Volume 00h = MUTE 01h = -71.625dB ... (0.375dB steps) C0h = 0dB FFh = 0dB	

Register 0403h AIF1 DAC1 Right Volume

REGISTER ADDRESS	BIT	LABEL	DEFAULT	DESCRIPTION	REFER TO
R1028 (0404h) AIF1 ADC2 Left Volume	8	AIF1ADC2_VU	0	AIF1ADC2 output path (AIF1, Timeslot 1) Volume Update Writing a 1 to this bit will cause the AIF1ADC2L and AIF1ADC2R volume to be updated simultaneously	
	7:0	AIF1ADC2L_VO L [7:0]	1100_0000	AIF1ADC2 (Left) output path (AIF1, Timeslot 1) Digital Volume 00h = MUTE 01h = -71.625dB ... (0.375dB steps) EFh = +17.625dB	

Register 0404h AIF1 ADC2 Left Volume

REGISTER ADDRESS	BIT	LABEL	DEFAULT	DESCRIPTION	REFER TO
R1029 (0405h) AIF1 ADC2 Right Volume	8	AIF1ADC2_VU	0	AIF1ADC2 output path (AIF1, Timeslot 1) Volume Update Writing a 1 to this bit will cause the AIF1ADC2L and AIF1ADC2R volume to be updated simultaneously	
	7:0	AIF1ADC2R_VO L [7:0]	1100_0000	AIF1ADC2 (Right) output path (AIF1, Timeslot 1) Digital Volume 00h = MUTE 01h = -71.625dB ... (0.375dB steps) EFh = +17.625dB	

Register 0405h AIF1 ADC2 Right Volume

REGISTER ADDRESS	BIT	LABEL	DEFAULT	DESCRIPTION	REFER TO
R1030 (0406h) AIF1 DAC2 Left Volume	8	AIF1DAC2_VU	0	AIF1DAC2 input path (AIF1, Timeslot 1) Volume Update Writing a 1 to this bit will cause the AIF1DAC2L and AIF1DAC2R volume to be updated simultaneously	
	7:0	AIF1DAC2L_VO L [7:0]	1100_0000	AIF1DAC2 (Left) input path (AIF1, Timeslot 1) Digital Volume 00h = MUTE 01h = -71.625dB ... (0.375dB steps) C0h = 0dB FFh = 0dB	

Register 0406h AIF1 DAC2 Left Volume

REGISTER ADDRESS	BIT	LABEL	DEFAULT	DESCRIPTION	REFER TO
R1031 (0407h) AIF1 DAC2 Right Volume	8	AIF1DAC2_VU	0	AIF1DAC2 input path (AIF1, Timeslot 1) Volume Update Writing a 1 to this bit will cause the AIF1DAC2L and AIF1DAC2R volume to be updated simultaneously	
	7:0	AIF1DAC2R_VO L [7:0]	1100_0000	AIF1DAC2 (Right) input path (AIF1, Timeslot 1) Digital Volume 00h = MUTE 01h = -71.625dB ... (0.375dB steps) C0h = 0dB FFh = 0dB	

Register 0407h AIF1 DAC2 Right Volume

REGISTER ADDRESS	BIT	LABEL	DEFAULT	DESCRIPTION	REFER TO
R1040 (0410h) AIF1 ADC1 Filters	15	AIF1ADC_4FS	0	Enable AIF1ADC ultrasonic mode (4FS) output, bypassing all AIF1 baseband output filtering 0 = Disabled 1 = Enabled	
	14:13	AIF1ADC1_HPF_CUT [1:0]	00	AIF1ADC1 output path (AIF1, Timeslot 0) Digital HPF cut-off frequency (fc) 00 = Hi-fi mode (fc = 4Hz at fs = 48kHz) 01 = Voice mode 1 (fc = 127Hz at fs = 8kHz) 10 = Voice mode 2 (fc = 130Hz at fs = 8kHz) 11 = Voice mode 3 (fc = 267Hz at fs = 8kHz)	
	12	AIF1ADC1L_HPF	0	AIF1ADC1 (Left) output path (AIF1, Timeslot 0) Digital HPF Enable 0 = Disabled 1 = Enabled	
	11	AIF1ADC1R_HPF	0	AIF1ADC1 (Right) output path (AIF1, Timeslot 0) Digital HPF Enable 0 = Disabled 1 = Enabled	

Register 0410h AIF1 ADC1 Filters

REGISTER ADDRESS	BIT	LABEL	DEFAULT	DESCRIPTION	REFER TO
R1041 (0411h) AIF1 ADC2 Filters	14:13	AIF1ADC2_HPF_CUT [1:0]	00	AIF1ADC2 output path (AIF1, Timeslot 1) Digital HPF cut-off frequency (fc) 00 = Hi-fi mode (fc = 4Hz at fs = 48kHz) 01 = Voice mode 1 (fc = 127Hz at fs = 8kHz) 10 = Voice mode 2 (fc = 130Hz at fs = 8kHz) 11 = Voice mode 3 (fc = 267Hz at fs = 8kHz)	
	12	AIF1ADC2L_HPF	0	AIF1ADC2 (Left) output path (AIF1, Timeslot 1) Digital HPF Enable 0 = Disabled 1 = Enabled	
	11	AIF1ADC2R_HPF	0	AIF1ADC2 (Right) output path (AIF1, Timeslot 1) Digital HPF Enable 0 = Disabled 1 = Enabled	

Register 0411h AIF1 ADC2 Filters

REGISTER ADDRESS	BIT	LABEL	DEFAULT	DESCRIPTION	REFER TO
R1056 (0420h) AIF1 DAC1 Filters (1)	9	AIF1DAC1_MUTE	1	AIF1DAC1 input path (AIF1, Timeslot 0) Soft Mute Control 0 = Un-mute 1 = Mute	
	7	AIF1DAC1_MONO	0	AIF1DAC1 input path (AIF1, Timeslot 0) Mono Mix Control 0 = Disabled 1 = Enabled	
	5	AIF1DAC1_MUTE_RATE	0	AIF1DAC1 input path (AIF1, Timeslot 0) Soft Mute Ramp Rate 0 = Fast ramp (fs/2, maximum ramp time is 10.7ms at fs=48k) 1 = Slow ramp (fs/32, maximum ramp time is 171ms at	

REGISTER ADDRESS	BIT	LABEL	DEFAULT	DESCRIPTION	REFER TO
				fs=48k) (Note: ramp rate scales with sample rate.)	
	4	AIF1DAC1_UNMUTE_RAMP	0	AIF1DAC1 input path (AIF1, Timeslot 0) Unmute Ramp select 0 = Disabling soft-mute (AIF1DAC1_MUTE=0) will cause the volume to change immediately to AIF1DAC1L_VOL and AIF1DAC1R_VOL settings 1 = Disabling soft-mute (AIF1DAC1_MUTE=0) will cause the DAC volume to ramp up gradually to the AIF1DAC1L_VOL and AIF1DAC1R_VOL settings	

Register 0420h AIF1 DAC1 Filters (1)

REGISTER ADDRESS	BIT	LABEL	DEFAULT	DESCRIPTION	REFER TO
R1057 (0421h) AIF1 DAC1 Filters (2)	13:9	AIF1DAC1_3D_GAIN [4:0]	0_0000	AIF1DAC1 playback path (AIF1, Timeslot 0) 3D Stereo depth 00000 = Off 00001 = Minimum (-16dB) ...(0.915dB steps) 11111 = Maximum (+11.45dB)	
	8	AIF1DAC1_3D_ENA	0	Enable 3D Stereo in AIF1DAC1 playback path (AIF1, Timeslot 0) 0 = Disabled 1 = Enabled	

Register 0421h AIF1 DAC1 Filters (2)

REGISTER ADDRESS	BIT	LABEL	DEFAULT	DESCRIPTION	REFER TO
R1058 (0422h) AIF1 DAC2 Filters (1)	9	AIF1DAC2_MUTE	1	AIF1DAC2 input path (AIF1, Timeslot 1) Soft Mute Control 0 = Un-mute 1 = Mute	
	7	AIF1DAC2_MONO	0	AIF1DAC2 input path (AIF1, Timeslot 1) Mono Mix Control 0 = Disabled 1 = Enabled	
	5	AIF1DAC2_MUTE_RATE	0	AIF1DAC2 input path (AIF1, Timeslot 1) Soft Mute Ramp Rate 0 = Fast ramp (fs/2, maximum ramp time is 10.7ms at fs=48k) 1 = Slow ramp (fs/32, maximum ramp time is 171ms at fs=48k) (Note: ramp rate scales with sample rate.)	
	4	AIF1DAC2_UNMUTE_RAMP	0	AIF1DAC2 input path (AIF1, Timeslot 1) Unmute Ramp select 0 = Disabling soft-mute (AIF1DAC2_MUTE=0) will cause the volume to change immediately to AIF1DAC2L_VOL and AIF1DAC2R_VOL settings 1 = Disabling soft-mute (AIF1DAC2_MUTE=0) will cause the DAC volume to ramp up gradually to the AIF1DAC2L_VOL and AIF1DAC2R_VOL settings	

Register 0422h AIF1 DAC2 Filters (1)

REGISTER ADDRESS	BIT	LABEL	DEFAULT	DESCRIPTION	REFER TO
R1059 (0423h) AIF1 DAC2 Filters (2)	13:9	AIF1DAC2_3D_ GAIN [4:0]	0_0000	AIF1DAC2 playback path (AIF1, Timeslot 1) 3D Stereo depth 00000 = Off 00001 = Minimum (-16dB) ...(0.915dB steps) 11111 = Maximum (+11.45dB)	
	8	AIF1DAC2_3D_ ENA	0	Enable 3D Stereo in AIF1DAC2 playback path (AIF1, Timeslot 1) 0 = Disabled 1 = Enabled	

Register 0423h AIF1 DAC2 Filters (2)

REGISTER ADDRESS	BIT	LABEL	DEFAULT	DESCRIPTION	REFER TO
R1072 (0430h) AIF1 DAC1 Noise Gate	6:5	AIF1DAC1_NG_ HLD [1:0]	11	AIF1DAC1 input path (AIF1, Timeslot 0) Noise Gate Hold Time (delay before noise gate is activated) 00 = 30ms 01 = 125ms 10 = 250ms 11 = 500ms	
	3:1	AIF1DAC1_NG_ THR [2:0]	100	AIF1DAC1 input path (AIF1, Timeslot 0) Noise Gate Threshold 000 = -60dB 001 = -66dB 010 = -72dB 011 = -78dB 100 = -84dB 101 = -90dB 110 = -96dB 111 = -102dB	
	0	AIF1DAC1_NG_ ENA	0	AIF1DAC1 input path (AIF1, Timeslot 0) Noise Gate Enable 0 = Disabled 1 = Enabled	

Register 0430h AIF1 DAC1 Noise Gate

REGISTER ADDRESS	BIT	LABEL	DEFAULT	DESCRIPTION	REFER TO
R1073 (0431h) AIF1 DAC2 Noise Gate	6:5	AIF1DAC2_NG_ HLD [1:0]	11	AIF1DAC2 input path (AIF1, Timeslot 1) Noise Gate Hold Time (delay before noise gate is activated) 00 = 30ms 01 = 125ms 10 = 250ms 11 = 500ms	
	3:1	AIF1DAC2_NG_ THR [2:0]	100	AIF1DAC2 input path (AIF1, Timeslot 1) Noise Gate Threshold 000 = -60dB 001 = -66dB 010 = -72dB 011 = -78dB 100 = -84dB 101 = -90dB	

REGISTER ADDRESS	BIT	LABEL	DEFAULT	DESCRIPTION	REFER TO
				110 = -96dB 111 = -102dB	
	0	AIF1DAC2_NG_ENA	0	AIF1DAC2 input path (AIF1, Timeslot 1) Noise Gate Enable 0 = Disabled 1 = Enabled	

Register 0431h AIF1 DAC2 Noise Gate

REGISTER ADDRESS	BIT	LABEL	DEFAULT	DESCRIPTION	REFER TO
R1088 (0440h) AIF1 DRC1 (1)	15:11	AIF1DRC1_SIG_DET_RMS [4:0]	0_0000	AIF1 DRC1 Signal Detect RMS Threshold. This is the RMS signal level for signal detect to be indicated when AIF1DRC1_SIG_DET_MODE=1. 00000 = -30dB 00001 = -31.5dB (1.5dB steps) 11110 = -75dB 11111 = -76.5dB	
	10:9	AIF1DRC1_SIG_DET_PK [1:0]	00	AIF1 DRC1 Signal Detect Peak Threshold. This is the Peak/RMS ratio, or Crest Factor, level for signal detect to be indicated when AIF1DRC1_SIG_DET_MODE=0. 00 = 12dB 01 = 18dB 10 = 24dB 11 = 30dB	
	8	AIF1DRC1_NG_ENA	0	AIF1 DRC1 Noise Gate Enable 0 = Disabled 1 = Enabled	
	7	AIF1DRC1_SIG_DET_MODE	1	AIF1 DRC1 Signal Detect Mode 0 = Peak threshold mode 1 = RMS threshold mode	
	6	AIF1DRC1_SIG_DET	0	AIF1 DRC1 Signal Detect Enable 0 = Disabled 1 = Enabled	
	5	AIF1DRC1_KNEE2_OP_ENA	0	AIF1 DRC1 KNEE2_OP Enable 0 = Disabled 1 = Enabled	
	4	AIF1DRC1_QR	1	AIF1 DRC1 Quick-release Enable 0 = Disabled 1 = Enabled	
	3	AIF1DRC1_ANT_ICLIP	1	AIF1 DRC1 Anti-clip Enable 0 = Disabled 1 = Enabled	
	2	AIF1DAC1_DRC_ENA	0	Enable DRC in AIF1DAC1 playback path (AIF1, Timeslot 0) 0 = Disabled 1 = Enabled	
	1	AIF1ADC1L_DR C_ENA	0	Enable DRC in AIF1ADC1 (Left) record path (AIF1, Timeslot 0) 0 = Disabled 1 = Enabled	

REGISTER ADDRESS	BIT	LABEL	DEFAULT	DESCRIPTION	REFER TO
	0	AIF1ADC1R_DR C_ENA	0	Enable DRC in AIF1ADC1 (Right) record path (AIF1, Timeslot 0) 0 = Disabled 1 = Enabled	

Register 0440h AIF1 DRC1 (1)

REGISTER ADDRESS	BIT	LABEL	DEFAULT	DESCRIPTION	REFER TO
R1089 (0441h) AIF1 DRC1 (2)	12:9	AIF1DRC1_ATK [3:0]	0100	AIF1 DRC1 Gain attack rate (seconds/6dB) 0000 = Reserved 0001 = 181us 0010 = 363us 0011 = 726us 0100 = 1.45ms 0101 = 2.9ms 0110 = 5.8ms 0111 = 11.6ms 1000 = 23.2ms 1001 = 46.4ms 1010 = 92.8ms 1011 = 185.6ms 1100-1111 = Reserved	
	8:5	AIF1DRC1_DCY [3:0]	0010	AIF1 DRC1 Gain decay rate (seconds/6dB) 0000 = 186ms 0001 = 372ms 0010 = 743ms 0011 = 1.49s 0100 = 2.97s 0101 = 5.94s 0110 = 11.89s 0111 = 23.78s 1000 = 47.56s 1001-1111 = Reserved	
	4:2	AIF1DRC1_MIN GAIN [2:0]	001	AIF1 DRC1 Minimum gain to attenuate audio signals 000 = 0dB 001 = -12dB (default) 010 = -18dB 011 = -24dB 100 = -36dB 101 = Reserved 11X = Reserved	
	1:0	AIF1DRC1_MA XGAIN [1:0]	01	AIF1 DRC1 Maximum gain to boost audio signals (dB) 00 = 12dB 01 = 18dB 10 = 24dB 11 = 36dB	

Register 0441h AIF1 DRC1 (2)

REGISTER ADDRESS	BIT	LABEL	DEFAULT	DESCRIPTION	REFER TO
R1090 (0442h) AIF1 DRC1 (3)	15:12	AIF1DRC1_NG_ MINGAIN [3:0]	0000	AIF1 DRC1 Minimum gain to attenuate audio signals when the noise gate is active. 0000 = -36dB 0001 = -30dB 0010 = -24dB 0011 = -18dB 0100 = -12dB 0101 = -6dB 0110 = 0dB 0111 = 6dB 1000 = 12dB 1001 = 18dB 1010 = 24dB 1011 = 30dB 1100 = 36dB 1101 to 1111 = Reserved	
	11:10	AIF1DRC1_NG_ EXP [1:0]	00	AIF1 DRC1 Noise Gate slope 00 = 1 (no expansion) 01 = 2 10 = 4 11 = 8	
	9:8	AIF1DRC1_QR_ THR [1:0]	00	AIF1 DRC1 Quick-release threshold (crest factor in dB) 00 = 12dB 01 = 18dB 10 = 24dB 11 = 30dB	
	7:6	AIF1DRC1_QR_ DCY [1:0]	00	AIF1 DRC1 Quick-release decay rate (seconds/6dB) 00 = 0.725ms 01 = 1.45ms 10 = 5.8ms 11 = Reserved	
	5:3	AIF1DRC1_HI_ COMP [2:0]	000	AIF1 DRC1 Compressor slope (upper region) 000 = 1 (no compression) 001 = 1/2 010 = 1/4 011 = 1/8 100 = 1/16 101 = 0 110 = Reserved 111 = Reserved	
	2:0	AIF1DRC1_LO_ COMP [2:0]	000	AIF1 DRC1 Compressor slope (lower region) 000 = 1 (no compression) 001 = 1/2 010 = 1/4 011 = 1/8 100 = 0 101 = Reserved 11X = Reserved	

Register 0442h AIF1 DRC1 (3)

REGISTER ADDRESS	BIT	LABEL	DEFAULT	DESCRIPTION	REFER TO
R1091 (0443h) AIF1 DRC1 (4)	10:5	AIF1DRC1_KNE E_IP [5:0]	00_0000	AIF1 DRC1 Input signal level at the Compressor 'Knee'. 000000 = 0dB 000001 = -0.75dB 000010 = -1.5dB ... (-0.75dB steps) 111100 = -45dB 111101 = Reserved 11111X = Reserved	
	4:0	AIF1DRC1_KNE E_OP [4:0]	0_0000	AIF1 DRC1 Output signal at the Compressor 'Knee'. 00000 = 0dB 00001 = -0.75dB 00010 = -1.5dB ... (-0.75dB steps) 11110 = -22.5dB 11111 = Reserved	

Register 0443h AIF1 DRC1 (4)

REGISTER ADDRESS	BIT	LABEL	DEFAULT	DESCRIPTION	REFER TO
R1092 (0444h) AIF1 DRC1 (5)	9:5	AIF1DRC1_KNE E2_IP [4:0]	0_0000	AIF1 DRC1 Input signal level at the Noise Gate threshold 'Knee2'. 00000 = -36dB 00001 = -37.5dB 00010 = -39dB ... (-1.5dB steps) 11110 = -81dB 11111 = -82.5dB Only applicable when AIF1DRC1_NG_ENA = 1.	
	4:0	AIF1DRC1_KNE E2_OP [4:0]	0_0000	AIF1 DRC1 Output signal at the Noise Gate threshold 'Knee2'. 00000 = -30dB 00001 = -31.5dB 00010 = -33dB ... (-1.5dB steps) 11110 = -75dB 11111 = -76.5dB Only applicable when AIF1DRC1_KNEE2_OP_ENA = 1.	

Register 0444h AIF1 DRC1 (5)

REGISTER ADDRESS	BIT	LABEL	DEFAULT	DESCRIPTION	REFER TO
R1104 (0450h) AIF1 DRC2 (1)	15:11	AIF1DRC2_SIG _DET_RMS [4:0]	0_0000	AIF1 DRC2 Signal Detect RMS Threshold. This is the RMS signal level for signal detect to be indicated when AIF1DRC2_SIG_DET_MODE=1. 00000 = -30dB 00001 = -31.5dB (1.5dB steps) 11110 = -75dB 11111 = -76.5dB	

REGISTER ADDRESS	BIT	LABEL	DEFAULT	DESCRIPTION	REFER TO
	10:9	AIF1DRC2_SIG_DET_PK [1:0]	00	AIF1 DRC2 Signal Detect Peak Threshold. This is the Peak/RMS ratio, or Crest Factor, level for signal detect to be indicated when AIF1DRC2_SIG_DET_MODE=0. 00 = 12dB 01 = 18dB 10 = 24dB 11 = 30dB	
	8	AIF1DRC2_NG_ENA	0	AIF1 DRC2 Noise Gate Enable 0 = Disabled 1 = Enabled	
	7	AIF1DRC2_SIG_DET_MODE	1	AIF1 DRC2 Signal Detect Mode 0 = Peak threshold mode 1 = RMS threshold mode	
	6	AIF1DRC2_SIG_DET	0	AIF1 DRC2 Signal Detect Enable 0 = Disabled 1 = Enabled	
	5	AIF1DRC2_KNEE2_OP_ENA	0	AIF1 DRC2 KNEE2_OP Enable 0 = Disabled 1 = Enabled	
	4	AIF1DRC2_QR	1	AIF1 DRC2 Quick-release Enable 0 = Disabled 1 = Enabled	
	3	AIF1DRC2_ANT_ICLIP	1	AIF1 DRC2 Anti-clip Enable 0 = Disabled 1 = Enabled	
	2	AIF1DAC2_DRC_ENA	0	Enable DRC in AIF1DAC2 playback path (AIF1, Timeslot 1) 0 = Disabled 1 = Enabled	
	1	AIF1ADC2L_DR_C_ENA	0	Enable DRC in AIF1ADC2 (Left) record path (AIF1, Timeslot 1) 0 = Disabled 1 = Enabled	
	0	AIF1ADC2R_DR_C_ENA	0	Enable DRC in AIF1ADC2 (Right) record path (AIF1, Timeslot 1) 0 = Disabled 1 = Enabled	

Register 0450h AIF1 DRC2 (1)

REGISTER ADDRESS	BIT	LABEL	DEFAULT	DESCRIPTION	REFER TO
R1105 (0451h) AIF1 DRC2 (2)	12:9	AIF1DRC2_ATK [3:0]	0100	AIF1 DRC2 Gain attack rate (seconds/6dB) 0000 = Reserved 0001 = 181us 0010 = 363us 0011 = 726us 0100 = 1.45ms 0101 = 2.9ms 0110 = 5.8ms 0111 = 11.6ms 1000 = 23.2ms 1001 = 46.4ms 1010 = 92.8ms 1011 = 185.6ms 1100-1111 = Reserved	
	8:5	AIF1DRC2_DCY [3:0]	0010	AIF1 DRC2 Gain decay rate (seconds/6dB) 0000 = 186ms 0001 = 372ms 0010 = 743ms 0011 = 1.49s 0100 = 2.97s 0101 = 5.94s 0110 = 11.89s 0111 = 23.78s 1000 = 47.56s 1001-1111 = Reserved	
	4:2	AIF1DRC2_MIN GAIN [2:0]	001	AIF1 DRC2 Minimum gain to attenuate audio signals 000 = 0dB 001 = -12dB (default) 010 = -18dB 011 = -24dB 100 = -36dB 101 = Reserved 11X = Reserved	
	1:0	AIF1DRC2_MA XGAIN [1:0]	01	AIF1 DRC2 Maximum gain to boost audio signals (dB) 00 = 12dB 01 = 18dB 10 = 24dB 11 = 36dB	

Register 0451h AIF1 DRC2 (2)

REGISTER ADDRESS	BIT	LABEL	DEFAULT	DESCRIPTION	REFER TO
R1106 (0452h) AIF1 DRC2 (3)	15:12	AIF1DRC2_NG_ MINGAIN [3:0]	0000	AIF1 DRC2 Minimum gain to attenuate audio signals when the noise gate is active. 0000 = -36dB 0001 = -30dB 0010 = -24dB 0011 = -18dB 0100 = -12dB 0101 = -6dB 0110 = 0dB 0111 = 6dB	

REGISTER ADDRESS	BIT	LABEL	DEFAULT	DESCRIPTION	REFER TO
				1000 = 12dB 1001 = 18dB 1010 = 24dB 1011 = 30dB 1100 = 36dB 1101 to 1111 = Reserved	
	11:10	AIF1DRC2_NG_EXP [1:0]	00	AIF1 DRC2 Noise Gate slope 00 = 1 (no expansion) 01 = 2 10 = 4 11 = 8	
	9:8	AIF1DRC2_QR_THR [1:0]	00	AIF1 DRC2 Quick-release threshold (crest factor in dB) 00 = 12dB 01 = 18dB 10 = 24dB 11 = 30dB	
	7:6	AIF1DRC2_QR_DCY [1:0]	00	AIF1 DRC2 Quick-release decay rate (seconds/6dB) 00 = 0.725ms 01 = 1.45ms 10 = 5.8ms 11 = Reserved	
	5:3	AIF1DRC2_HI_COMP [2:0]	000	AIF1 DRC2 Compressor slope (upper region) 000 = 1 (no compression) 001 = 1/2 010 = 1/4 011 = 1/8 100 = 1/16 101 = 0 110 = Reserved 111 = Reserved	
	2:0	AIF1DRC2_LO_COMP [2:0]	000	AIF1 DRC2 Compressor slope (lower region) 000 = 1 (no compression) 001 = 1/2 010 = 1/4 011 = 1/8 100 = 0 101 = Reserved 11X = Reserved	

Register 0452h AIF1 DRC2 (3)

REGISTER ADDRESS	BIT	LABEL	DEFAULT	DESCRIPTION	REFER TO
R1107 (0453h) AIF1 DRC2 (4)	10:5	AIF1DRC2_KNEE_IP [5:0]	00_0000	AIF1 DRC2 Input signal level at the Compressor 'Knee'. 000000 = 0dB 000001 = -0.75dB 000010 = -1.5dB ... (-0.75dB steps) 111100 = -45dB 111101 = Reserved 11111X = Reserved	
	4:0	AIF1DRC2_KNEE_OP [4:0]	0_0000	AIF1 DRC2 Output signal at the Compressor 'Knee'. 00000 = 0dB	

REGISTER ADDRESS	BIT	LABEL	DEFAULT	DESCRIPTION	REFER TO
				00001 = -0.75dB 00010 = -1.5dB ... (-0.75dB steps) 11110 = -22.5dB 11111 = Reserved	

Register 0453h AIF1 DRC2 (4)

REGISTER ADDRESS	BIT	LABEL	DEFAULT	DESCRIPTION	REFER TO
R1108 (0454h) AIF1 DRC2 (5)	9:5	AIF1DRC2_KNE E2_IP [4:0]	0_0000	AIF1 DRC2 Input signal level at the Noise Gate threshold 'Knee2'. 00000 = -36dB 00001 = -37.5dB 00010 = -39dB ... (-1.5dB steps) 11110 = -81dB 11111 = -82.5dB Only applicable when AIF1DRC2_NG_ENA = 1.	
	4:0	AIF1DRC2_KNE E2_OP [4:0]	0_0000	AIF1 DRC2 Output signal at the Noise Gate threshold 'Knee2'. 00000 = -30dB 00001 = -31.5dB 00010 = -33dB ... (-1.5dB steps) 11110 = -75dB 11111 = -76.5dB Only applicable when AIF1DRC2_KNEE2_OP_ENA = 1.	

Register 0454h AIF1 DRC2 (5)

REGISTER ADDRESS	BIT	LABEL	DEFAULT	DESCRIPTION	REFER TO
R1152 (0480h) AIF1 DAC1 EQ Gains (1)	15:11	AIF1DAC1_EQ_ B1_GAIN [4:0]	0_1100	AIF1DAC1 (AIF1, Timeslot 0) EQ Band 1 Gain -12dB to +12dB in 1dB steps	
	10:6	AIF1DAC1_EQ_ B2_GAIN [4:0]	0_1100	AIF1DAC1 (AIF1, Timeslot 0) EQ Band 2 Gain -12dB to +12dB in 1dB steps	
	5:1	AIF1DAC1_EQ_ B3_GAIN [4:0]	0_1100	AIF1DAC1 (AIF1, Timeslot 0) EQ Band 3 Gain -12dB to +12dB in 1dB steps	
	0	AIF1DAC1_EQ_ ENA	0	Enable EQ in AIF1DAC1 playback path (AIF1, Timeslot 0) 0 = Disabled 1 = Enabled	

Register 0480h AIF1 DAC1 EQ Gains (1)

REGISTER ADDRESS	BIT	LABEL	DEFAULT	DESCRIPTION	REFER TO
R1153 (0481h) AIF1 DAC1 EQ Gains (2)	15:11	AIF1DAC1_EQ_ B4_GAIN [4:0]	0_1100	AIF1DAC1 (AIF1, Timeslot 0) EQ Band 4 Gain -12dB to +12dB in 1dB steps	
	10:6	AIF1DAC1_EQ_ B5_GAIN [4:0]	0_1100	AIF1DAC1 (AIF1, Timeslot 0) EQ Band 5 Gain -12dB to +12dB in 1dB steps	
	0	AIF1DAC1_EQ_ MODE	0	AIF1DAC1 (AIF1, Timeslot 0) EQ Band 1 Mode 0 = Shelving filter 1 = Peak filter	

Register 0481h AIF1 DAC1 EQ Gains (2)

REGISTER ADDRESS	BIT	LABEL	DEFAULT	DESCRIPTION	REFER TO
R1154 (0482h) AIF1 DAC1 EQ Band 1 A	15:0	AIF1DAC1_EQ_ B1_A [15:0]	0000_1111 _1100_101 0	EQ Band 1 Coefficient A	

Register 0482h AIF1 DAC1 EQ Band 1 A

REGISTER ADDRESS	BIT	LABEL	DEFAULT	DESCRIPTION	REFER TO
R1155 (0483h) AIF1 DAC1 EQ Band 1 B	15:0	AIF1DAC1_EQ_ B1_B [15:0]	0000_0100 _0000_000 0	EQ Band 1 Coefficient B	

Register 0483h AIF1 DAC1 EQ Band 1 B

REGISTER ADDRESS	BIT	LABEL	DEFAULT	DESCRIPTION	REFER TO
R1156 (0484h) AIF1 DAC1 EQ Band 1 PG	15:0	AIF1DAC1_EQ_ B1_PG [15:0]	0000_0000 _1101_100 0	EQ Band 1 Coefficient PG	

Register 0484h AIF1 DAC1 EQ Band 1 PG

REGISTER ADDRESS	BIT	LABEL	DEFAULT	DESCRIPTION	REFER TO
R1157 (0485h) AIF1 DAC1 EQ Band 2 A	15:0	AIF1DAC1_EQ_ B2_A [15:0]	0001_1110 _1011_010 1	EQ Band 2 Coefficient A	

Register 0485h AIF1 DAC1 EQ Band 2 A

REGISTER ADDRESS	BIT	LABEL	DEFAULT	DESCRIPTION	REFER TO
R1158 (0486h) AIF1 DAC1 EQ Band 2 B	15:0	AIF1DAC1_EQ_ B2_B [15:0]	1111_0001 _0100_010 1	EQ Band 2 Coefficient B	

Register 0486h AIF1 DAC1 EQ Band 2 B

REGISTER ADDRESS	BIT	LABEL	DEFAULT	DESCRIPTION	REFER TO
R1159 (0487h) AIF1 DAC1 EQ Band 2 C	15:0	AIF1DAC1_EQ_ B2_C [15:0]	0000_1011 _0111_010 1	EQ Band 2 Coefficient C	

Register 0487h AIF1 DAC1 EQ Band 2 C

REGISTER ADDRESS	BIT	LABEL	DEFAULT	DESCRIPTION	REFER TO
R1160 (0488h) AIF1 DAC1 EQ Band 2 PG	15:0	AIF1DAC1_EQ_ B2_PG [15:0]	0000_0001 _1100_010 1	EQ Band 2 Coefficient PG	

Register 0488h AIF1 DAC1 EQ Band 2 PG

REGISTER ADDRESS	BIT	LABEL	DEFAULT	DESCRIPTION	REFER TO
R1161 (0489h) AIF1 DAC1 EQ Band 3 A	15:0	AIF1DAC1_EQ_ B3_A [15:0]	0001_1100 _0101_100 0	EQ Band 3 Coefficient A	

Register 0489h AIF1 DAC1 EQ Band 3 A

REGISTER ADDRESS	BIT	LABEL	DEFAULT	DESCRIPTION	REFER TO
R1162 (048Ah) AIF1 DAC1 EQ Band 3 B	15:0	AIF1DAC1_EQ_ B3_B [15:0]	1111_0011 _0111_001 1	EQ Band 3 Coefficient B	

Register 048Ah AIF1 DAC1 EQ Band 3 B

REGISTER ADDRESS	BIT	LABEL	DEFAULT	DESCRIPTION	REFER TO
R1163 (048Bh) AIF1 DAC1 EQ Band 3 C	15:0	AIF1DAC1_EQ_ B3_C [15:0]	0000_1010 _0101_010 0	EQ Band 3 Coefficient C	

Register 048Bh AIF1 DAC1 EQ Band 3 C

REGISTER ADDRESS	BIT	LABEL	DEFAULT	DESCRIPTION	REFER TO
R1164 (048Ch) AIF1 DAC1 EQ Band 3 PG	15:0	AIF1DAC1_EQ_ B3_PG [15:0]	0000_0101 _0101_100 0	EQ Band 3 Coefficient PG	

Register 048Ch AIF1 DAC1 EQ Band 3 PG

REGISTER ADDRESS	BIT	LABEL	DEFAULT	DESCRIPTION	REFER TO
R1165 (048Dh) AIF1 DAC1 EQ Band 4 A	15:0	AIF1DAC1_EQ_ B4_A [15:0]	0001_0110 _1000_111 0	EQ Band 4 Coefficient A	

Register 048Dh AIF1 DAC1 EQ Band 4 A

REGISTER ADDRESS	BIT	LABEL	DEFAULT	DESCRIPTION	REFER TO
R1166 (048Eh) AIF1 DAC1 EQ Band 4 B	15:0	AIF1DAC1_EQ_ B4_B [15:0]	1111_1000 _0010_100 1	EQ Band 4 Coefficient B	

Register 048Eh AIF1 DAC1 EQ Band 4 B

REGISTER ADDRESS	BIT	LABEL	DEFAULT	DESCRIPTION	REFER TO
R1167 (048Fh) AIF1 DAC1 EQ Band 4 C	15:0	AIF1DAC1_EQ_ B4_C [15:0]	0000_0111 _1010_110 1	EQ Band 4 Coefficient C	

Register 048Fh AIF1 DAC1 EQ Band 4 C

REGISTER ADDRESS	BIT	LABEL	DEFAULT	DESCRIPTION	REFER TO
R1168 (0490h) AIF1 DAC1 EQ Band 4 PG	15:0	AIF1DAC1_EQ_ B4_PG [15:0]	0001_0001 _0000_001 1	EQ Band 4 Coefficient PG	

Register 0490h AIF1 DAC1 EQ Band 4 PG

REGISTER ADDRESS	BIT	LABEL	DEFAULT	DESCRIPTION	REFER TO
R1169 (0491h) AIF1 DAC1 EQ Band 5 A	15:0	AIF1DAC1_EQ_ B5_A [15:0]	0000_0101 _0110_010 0	EQ Band 5 Coefficient A	

Register 0491h AIF1 DAC1 EQ Band 5 A

REGISTER ADDRESS	BIT	LABEL	DEFAULT	DESCRIPTION	REFER TO
R1170 (0492h) AIF1 DAC1 EQ Band 5 B	15:0	AIF1DAC1_EQ_ B5_B [15:0]	0000_0101 _0101_100 1	EQ Band 5 Coefficient B	

Register 0492h AIF1 DAC1 EQ Band 5 B

REGISTER ADDRESS	BIT	LABEL	DEFAULT	DESCRIPTION	REFER TO
R1171 (0493h) AIF1 DAC1 EQ Band 5 PG	15:0	AIF1DAC1_EQ_ B5_PG [15:0]	0100_0000 _0000_000 0	EQ Band 5 Coefficient PG	

Register 0493h AIF1 DAC1 EQ Band 5 PG

REGISTER ADDRESS	BIT	LABEL	DEFAULT	DESCRIPTION	REFER TO
R1184 (04A0h) AIF1 DAC2 EQ Gains (1)	15:11	AIF1DAC2_EQ_ B1_GAIN [4:0]	0_1100	AIF1DAC2 (AIF1, Timeslot 1) EQ Band 1 Gain -12dB to +12dB in 1dB steps	
	10:6	AIF1DAC2_EQ_ B2_GAIN [4:0]	0_1100	AIF1DAC2 (AIF1, Timeslot 1) EQ Band 2 Gain -12dB to +12dB in 1dB steps	
	5:1	AIF1DAC2_EQ_ B3_GAIN [4:0]	0_1100	AIF1DAC2 (AIF1, Timeslot 1) EQ Band 3 Gain -12dB to +12dB in 1dB steps	
	0	AIF1DAC2_EQ_ ENA	0	Enable EQ in AIF1DAC2 playback path (AIF1, Timeslot 1) 0 = Disabled 1 = Enabled	

Register 04A0h AIF1 DAC2 EQ Gains (1)

REGISTER ADDRESS	BIT	LABEL	DEFAULT	DESCRIPTION	REFER TO
R1185 (04A1h) AIF1 DAC2 EQ Gains (2)	15:11	AIF1DAC2_EQ_ B4_GAIN [4:0]	0_1100	AIF1DAC2 (AIF1, Timeslot 1) EQ Band 4 Gain -12dB to +12dB in 1dB steps	
	10:6	AIF1DAC2_EQ_ B5_GAIN [4:0]	0_1100	AIF1DAC2 (AIF1, Timeslot 1) EQ Band 5 Gain -12dB to +12dB in 1dB steps	
	0	AIF1DAC2_EQ_ MODE	0	AIF1DAC2 (AIF1, Timeslot 1) EQ Band 1 Mode 0 = Shelving filter 1 = Peak filter	

Register 04A1h AIF1 DAC2 EQ Gains (2)

REGISTER ADDRESS	BIT	LABEL	DEFAULT	DESCRIPTION	REFER TO
R1186 (04A2h) AIF1 DAC2 EQ Band 1 A	15:0	AIF1DAC2_EQ_ B1_A [15:0]	0000_1111 _1100_101 0	EQ Band 1 Coefficient A	

Register 04A2h AIF1 DAC2 EQ Band 1 A

REGISTER ADDRESS	BIT	LABEL	DEFAULT	DESCRIPTION	REFER TO
R1187 (04A3h) AIF1 DAC2 EQ Band 1 B	15:0	AIF1DAC2_EQ_ B1_B [15:0]	0000_0100 _0000_000 0	EQ Band 1 Coefficient B	

Register 04A3h AIF1 DAC2 EQ Band 1 B

REGISTER ADDRESS	BIT	LABEL	DEFAULT	DESCRIPTION	REFER TO
R1188 (04A4h) AIF1 DAC2 EQ Band 1 PG	15:0	AIF1DAC2_EQ_ B1_PG [15:0]	0000_0000 _1101_100 0	EQ Band 1 Coefficient PG	

Register 04A4h AIF1 DAC2 EQ Band 1 PG

REGISTER ADDRESS	BIT	LABEL	DEFAULT	DESCRIPTION	REFER TO
R1189 (04A5h) AIF1 DAC2 EQ Band 2 A	15:0	AIF1DAC2_EQ_ B2_A [15:0]	0001_1110 _1011_010 1	EQ Band 2 Coefficient A	

Register 04A5h AIF1 DAC2 EQ Band 2 A

REGISTER ADDRESS	BIT	LABEL	DEFAULT	DESCRIPTION	REFER TO
R1190 (04A6h) AIF1 DAC2 EQ Band 2 B	15:0	AIF1DAC2_EQ_ B2_B [15:0]	1111_0001 _0100_010 1	EQ Band 2 Coefficient B	

Register 04A6h AIF1 DAC2 EQ Band 2 B

REGISTER ADDRESS	BIT	LABEL	DEFAULT	DESCRIPTION	REFER TO
R1191 (04A7h) AIF1 DAC2 EQ Band 2 C	15:0	AIF1DAC2_EQ_ B2_C [15:0]	0000_1011 _0111_010 1	EQ Band 2 Coefficient C	

Register 04A7h AIF1 DAC2 EQ Band 2 C

REGISTER ADDRESS	BIT	LABEL	DEFAULT	DESCRIPTION	REFER TO
R1192 (04A8h) AIF1 DAC2 EQ Band 2 PG	15:0	AIF1DAC2_EQ_ B2_PG [15:0]	0000_0001 _1100_010 1	EQ Band 2 Coefficient PG	

Register 04A8h AIF1 DAC2 EQ Band 2 PG

REGISTER ADDRESS	BIT	LABEL	DEFAULT	DESCRIPTION	REFER TO
R1193 (04A9h) AIF1 DAC2 EQ Band 3 A	15:0	AIF1DAC2_EQ_ B3_A [15:0]	0001_1100 _0101_100 0	EQ Band 3 Coefficient A	

Register 04A9h AIF1 DAC2 EQ Band 3 A

REGISTER ADDRESS	BIT	LABEL	DEFAULT	DESCRIPTION	REFER TO
R1194 (04AAh) AIF1 DAC2 EQ Band 3 B	15:0	AIF1DAC2_EQ_ B3_B [15:0]	1111_0011 _0111_001 1	EQ Band 3 Coefficient B	

Register 04AAh AIF1 DAC2 EQ Band 3 B

REGISTER ADDRESS	BIT	LABEL	DEFAULT	DESCRIPTION	REFER TO
R1195 (04ABh) AIF1 DAC2 EQ Band 3 C	15:0	AIF1DAC2_EQ_ B3_C [15:0]	0000_1010 _0101_010 0	EQ Band 3 Coefficient C	

Register 04ABh AIF1 DAC2 EQ Band 3 C

REGISTER ADDRESS	BIT	LABEL	DEFAULT	DESCRIPTION	REFER TO
R1196 (04ACh) AIF1 DAC2 EQ Band 3 PG	15:0	AIF1DAC2_EQ_ B3_PG [15:0]	0000_0101 _0101_100 0	EQ Band 3 Coefficient PG	

Register 04ACh AIF1 DAC2 EQ Band 3 PG

REGISTER ADDRESS	BIT	LABEL	DEFAULT	DESCRIPTION	REFER TO
R1197 (04ADh) AIF1 DAC2 EQ Band 4 A	15:0	AIF1DAC2_EQ_ B4_A [15:0]	0001_0110 _1000_111 0	EQ Band 4 Coefficient A	

Register 04ADh AIF1 DAC2 EQ Band 4 A

REGISTER ADDRESS	BIT	LABEL	DEFAULT	DESCRIPTION	REFER TO
R1198 (04AEh) AIF1 DAC2 EQ Band 4 B	15:0	AIF1DAC2_EQ_ B4_B [15:0]	1111_1000 _0010_100 1	EQ Band 4 Coefficient B	

Register 04AEh AIF1 DAC2 EQ Band 4 B

REGISTER ADDRESS	BIT	LABEL	DEFAULT	DESCRIPTION	REFER TO
R1199 (04AFh) AIF1 DAC2 EQ Band 4 C	15:0	AIF1DAC2_EQ_ B4_C [15:0]	0000_0111 _1010_110 1	EQ Band 4 Coefficient C	

Register 04AFh AIF1 DAC2 EQ Band 4 C

REGISTER ADDRESS	BIT	LABEL	DEFAULT	DESCRIPTION	REFER TO
R1200 (04B0h) AIF1 DAC2 EQ Band 4 PG	15:0	AIF1DAC2_EQ_ B4_PG [15:0]	0001_0001 _0000_001 1	EQ Band 4 Coefficient PG	

Register 04B0h AIF1 DAC2 EQ Band 4 PG

REGISTER ADDRESS	BIT	LABEL	DEFAULT	DESCRIPTION	REFER TO
R1201 (04B1h) AIF1 DAC2 EQ Band 5 A	15:0	AIF1DAC2_EQ_ B5_A [15:0]	0000_0101 _0110_010 0	EQ Band 5 Coefficient A	

Register 04B1h AIF1 DAC2 EQ Band 5 A

REGISTER ADDRESS	BIT	LABEL	DEFAULT	DESCRIPTION	REFER TO
R1202 (04B2h) AIF1 DAC2 EQ Band 5 B	15:0	AIF1DAC2_EQ_ B5_B [15:0]	0000_0101 _0101_100 1	EQ Band 5 Coefficient B	

Register 04B2h AIF1 DAC2 EQ Band 5 B

REGISTER ADDRESS	BIT	LABEL	DEFAULT	DESCRIPTION	REFER TO
R1203 (04B3h) AIF1 DAC2 EQ Band 5 PG	15:0	AIF1DAC2_EQ_ B5_PG [15:0]	0100_0000 _0000_000 0	EQ Band 5 Coefficient PG	

Register 04B3h AIF1 DAC2 EQ Band 5 PG

REGISTER ADDRESS	BIT	LABEL	DEFAULT	DESCRIPTION	REFER TO
R1280 (0500h) AIF2 ADC Left Volume	8	AIF2ADC_VU	0	AIF2ADC output path Volume Update Writing a 1 to this bit will cause the AIF2ADCL and AIF2ADCR volume to be updated simultaneously	
	7:0	AIF2ADCL_VOL [7:0]	1100_0000	AIF2ADC (Left) output path Digital Volume 00h = MUTE 01h = -71.625dB ... (0.375dB steps) EFh = +17.625dB	

Register 0500h AIF2 ADC Left Volume

REGISTER ADDRESS	BIT	LABEL	DEFAULT	DESCRIPTION	REFER TO
R1281 (0501h) AIF2 ADC Right Volume	8	AIF2ADC_VU	0	AIF2ADC output path Volume Update Writing a 1 to this bit will cause the AIF2ADCL and AIF2ADCR volume to be updated simultaneously	
	7:0	AIF2ADCR_VOL [7:0]	1100_0000	AIF2ADC (Right) output path Digital Volume 00h = MUTE 01h = -71.625dB ... (0.375dB steps) EFh = +17.625dB	

Register 0501h AIF2 ADC Right Volume

REGISTER ADDRESS	BIT	LABEL	DEFAULT	DESCRIPTION	REFER TO
R1282 (0502h) AIF2 DAC Left Volume	8	AIF2DAC_VU	0	AIF2DAC input path Volume Update Writing a 1 to this bit will cause the AIF2DACL and AIF2DACR volume to be updated simultaneously	
	7:0	AIF2DACL_VOL [7:0]	1100_0000	AIF2DAC (Left) input path Digital Volume 00h = MUTE 01h = -71.625dB ... (0.375dB steps) C0h = 0dB FFh = 0dB	

Register 0502h AIF2 DAC Left Volume

REGISTER ADDRESS	BIT	LABEL	DEFAULT	DESCRIPTION	REFER TO
R1283 (0503h) AIF2 DAC Right Volume	8	AIF2DAC_VU	0	AIF2DAC input path Volume Update Writing a 1 to this bit will cause the AIF2DACL and AIF2DACR volume to be updated simultaneously	
	7:0	AIF2DACR_VOL [7:0]	1100_0000	AIF2DAC (Right) input path Digital Volume 00h = MUTE 01h = -71.625dB ... (0.375dB steps) C0h = 0dB FFh = 0dB	

Register 0503h AIF2 DAC Right Volume

REGISTER ADDRESS	BIT	LABEL	DEFAULT	DESCRIPTION	REFER TO
R1296 (0510h) AIF2 ADC Filters	14:13	AIF2ADC_HPF_ CUT [1:0]	00	AIF2ADC output path Digital HPF Cut-Off Frequency (fc) 00 = Hi-fi mode (fc = 4Hz at fs = 48kHz) 01 = Voice mode 1 (fc = 127Hz at fs = 8kHz) 10 = Voice mode 2 (fc = 130Hz at fs = 8kHz) 11 = Voice mode 3 (fc = 267Hz at fs = 8kHz)	
	12	AIF2ADCL_HPF	0	AIF2ADC (Left) output path Digital HPF Enable 0 = Disabled 1 = Enabled	
	11	AIF2ADCR_HPF	0	AIF2ADC (Right) output path Digital HPF Enable 0 = Disabled 1 = Enabled	

Register 0510h AIF2 ADC Filters

REGISTER ADDRESS	BIT	LABEL	DEFAULT	DESCRIPTION	REFER TO
R1312 (0520h) AIF2 DAC Filters (1)	9	AIF2DAC_MUT E	1	AIF2DAC input path Soft Mute Control 0 = Un-mute 1 = Mute	
	7	AIF2DAC_MON O	0	AIF2DAC input path Mono Mix Control 0 = Disabled 1 = Enabled	
	5	AIF2DAC_MUT ERATE	0	AIF2DAC input path Soft Mute Ramp Rate 0 = Fast ramp (fs/2, maximum ramp time is 10.7ms at fs=48k) 1 = Slow ramp (fs/32, maximum ramp time is 171ms at fs=48k) (Note: ramp rate scales with sample rate.)	
	4	AIF2DAC_UNM UTE_RAMP	0	AIF2DAC input path Unmute Ramp select 0 = Disabling soft-mute (AIF2DAC_MUTE=0) will cause the volume to change immediately to AIF2DACL_VOL and AIF2DACR_VOL settings 1 = Disabling soft-mute (AIF2DAC_MUTE=0) will cause the DAC volume to ramp up gradually to the AIF2DACL_VOL and AIF2DACR_VOL settings	

Register 0520h AIF2 DAC Filters (1)

REGISTER ADDRESS	BIT	LABEL	DEFAULT	DESCRIPTION	REFER TO
R1313 (0521h) AIF2 DAC Filters (2)	13:9	AIF2DAC_3D_G AIN [4:0]	0_0000	AIF2DAC playback path 3D Stereo depth 00000 = Off 00001 = Minimum (-16dB) ...(0.915dB steps) 11111 = Maximum (+11.45dB)	
	8	AIF2DAC_3D_E NA	0	Enable 3D Stereo in AIF2DAC playback path 0 = Disabled 1 = Enabled	

Register 0521h AIF2 DAC Filters (2)

REGISTER ADDRESS	BIT	LABEL	DEFAULT	DESCRIPTION	REFER TO
R1328 (0430h) AIF2 DAC Noise Gate	6:5	AIF2DAC_NG_H LD [1:0]	11	AIF2DAC input path Noise Gate Hold Time (delay before noise gate is activated) 00 = 30ms 01 = 125ms 10 = 250ms 11 = 500ms	
	3:1	AIF2DAC_NG_T HR [2:0]	100	AIF2DAC input path Noise Gate Threshold 000 = -60dB 001 = -66dB 010 = -72dB 011 = -78dB 100 = -84dB 101 = -90dB 110 = -96dB 111 = -102dB	

REGISTER ADDRESS	BIT	LABEL	DEFAULT	DESCRIPTION	REFER TO
	0	AIF2DAC_NG_ENA	0	AIF2DAC input path Noise Gate Enable 0 = Disabled 1 = Enabled	

Register 0530h AIF2 DAC Noise Gate

REGISTER ADDRESS	BIT	LABEL	DEFAULT	DESCRIPTION	REFER TO
R1344 (0540h) AIF2 DRC (1)	15:11	AIF2DRC_SIG_DET_RMS [4:0]	0_0000	AIF2 DRC Signal Detect RMS Threshold. This is the RMS signal level for signal detect to be indicated when AIF2DRC_SIG_DET_MODE=1. 00000 = -30dB 00001 = -31.5dB (1.5dB steps) 11110 = -75dB 11111 = -76.5dB	
	10:9	AIF2DRC_SIG_DET_PK [1:0]	00	AIF2 DRC Signal Detect Peak Threshold. This is the Peak/RMS ratio, or Crest Factor, level for signal detect to be indicated when AIF2DRC_SIG_DET_MODE=0. 00 = 12dB 01 = 18dB 10 = 24dB 11 = 30dB	
	8	AIF2DRC_NG_ENA	0	AIF2 DRC Noise Gate Enable 0 = Disabled 1 = Enabled	
	7	AIF2DRC_SIG_DET_MODE	1	AIF2 DRC Signal Detect Mode 0 = Peak threshold mode 1 = RMS threshold mode	
	6	AIF2DRC_SIG_DET	0	AIF2 DRC Signal Detect Enable 0 = Disabled 1 = Enabled	
	5	AIF2DRC_KNEE2_OP_ENA	0	AIF2 DRC KNEE2_OP Enable 0 = Disabled 1 = Enabled	
	4	AIF2DRC_QR	1	AIF2 DRC Quick-release Enable 0 = Disabled 1 = Enabled	
	3	AIF2DRC_ANTI_CLIP	1	AIF2 DRC Anti-clip Enable 0 = Disabled 1 = Enabled	
	2	AIF2DAC_DRC_ENA	0	Enable DRC in AIF2DAC playback path 0 = Disabled 1 = Enabled	
	1	AIF2ADCL_DRC_ENA	0	Enable DRC in AIF2ADC (Left) record path 0 = Disabled 1 = Enabled	
	0	AIF2ADCR_DRC_ENA	0	Enable DRC in AIF2ADC (Right) record path 0 = Disabled 1 = Enabled	

Register 0540h AIF2 DRC (1)

REGISTER ADDRESS	BIT	LABEL	DEFAULT	DESCRIPTION	REFER TO
R1345 (0541h) AIF2 DRC (2)	12:9	AIF2DRC_ATK [3:0]	0100	AIF2 DRC Gain attack rate (seconds/6dB) 0000 = Reserved 0001 = 181us 0010 = 363us 0011 = 726us 0100 = 1.45ms 0101 = 2.9ms 0110 = 5.8ms 0111 = 11.6ms 1000 = 23.2ms 1001 = 46.4ms 1010 = 92.8ms 1011 = 185.6ms 1100-1111 = Reserved	
	8:5	AIF2DRC_DCY [3:0]	0010	AIF2 DRC Gain decay rate (seconds/6dB) 0000 = 186ms 0001 = 372ms 0010 = 743ms 0011 = 1.49s 0100 = 2.97s 0101 = 5.94s 0110 = 11.89s 0111 = 23.78s 1000 = 47.56s 1001-1111 = Reserved	
	4:2	AIF2DRC_MING AIN [2:0]	001	AIF2 DRC Minimum gain to attenuate audio signals 000 = 0dB 001 = -12dB (default) 010 = -18dB 011 = -24dB 100 = -36dB 101 = Reserved 11X = Reserved	
	1:0	AIF2DRC_MAX GAIN [1:0]	01	AIF2 DRC Maximum gain to boost audio signals (dB) 00 = 12dB 01 = 18dB 10 = 24dB 11 = 36dB	

Register 0541h AIF2 DRC (2)

REGISTER ADDRESS	BIT	LABEL	DEFAULT	DESCRIPTION	REFER TO
R1346 (0542h) AIF2 DRC (3)	15:12	AIF2DRC_NG_MINGAIN [3:0]	0000	AIF2 DRC Minimum gain to attenuate audio signals when the noise gate is active. 0000 = -36dB 0001 = -30dB 0010 = -24dB 0011 = -18dB 0100 = -12dB 0101 = -6dB 0110 = 0dB 0111 = 6dB 1000 = 12dB 1001 = 18dB 1010 = 24dB 1011 = 30dB 1100 = 36dB 1101 to 1111 = Reserved	
	11:10	AIF2DRC_NG_EXP [1:0]	00	AIF2 DRC Noise Gate slope 00 = 1 (no expansion) 01 = 2 10 = 4 11 = 8	
	9:8	AIF2DRC_QR_THR [1:0]	00	AIF2 DRC Quick-release threshold (crest factor in dB) 00 = 12dB 01 = 18dB 10 = 24dB 11 = 30dB	
	7:6	AIF2DRC_QR_DECY [1:0]	00	AIF2 DRC Quick-release decay rate (seconds/6dB) 00 = 0.725ms 01 = 1.45ms 10 = 5.8ms 11 = Reserved	
	5:3	AIF2DRC_HI_COMP [2:0]	000	AIF2 DRC Compressor slope (upper region) 000 = 1 (no compression) 001 = 1/2 010 = 1/4 011 = 1/8 100 = 1/16 101 = 0 110 = Reserved 111 = Reserved	
	2:0	AIF2DRC_LO_COMP [2:0]	000	AIF2 DRC Compressor slope (lower region) 000 = 1 (no compression) 001 = 1/2 010 = 1/4 011 = 1/8 100 = 0 101 = Reserved 11X = Reserved	

Register 0542h AIF2 DRC (3)

REGISTER ADDRESS	BIT	LABEL	DEFAULT	DESCRIPTION	REFER TO
R1347 (0543h) AIF2 DRC (4)	10:5	AIF2DRC_KNE E_IP [5:0]	00_0000	AIF2 DRC Input signal level at the Compressor 'Knee'. 000000 = 0dB 000001 = -0.75dB 000010 = -1.5dB ... (-0.75dB steps) 111100 = -45dB 111101 = Reserved 11111X = Reserved	
	4:0	AIF2DRC_KNE E_OP [4:0]	0_0000	AIF2 DRC Output signal at the Compressor 'Knee'. 00000 = 0dB 00001 = -0.75dB 00010 = -1.5dB ... (-0.75dB steps) 11110 = -22.5dB 11111 = Reserved	

Register 0543h AIF2 DRC (4)

REGISTER ADDRESS	BIT	LABEL	DEFAULT	DESCRIPTION	REFER TO
R1348 (0544h) AIF2 DRC (5)	9:5	AIF2DRC_KNE E2_IP [4:0]	0_0000	AIF2 DRC Input signal level at the Noise Gate threshold 'Knee2'. 00000 = -36dB 00001 = -37.5dB 00010 = -39dB ... (-1.5dB steps) 11110 = -81dB 11111 = -82.5dB Only applicable when AIF2DRC_NG_ENA = 1.	
	4:0	AIF2DRC_KNE E2_OP [4:0]	0_0000	AIF2 DRC Output signal at the Noise Gate threshold 'Knee2'. 00000 = -30dB 00001 = -31.5dB 00010 = -33dB ... (-1.5dB steps) 11110 = -75dB 11111 = -76.5dB Only applicable when AIF2DRC_KNEE2_OP_ENA = 1.	

Register 0544h AIF2 DRC (5)

REGISTER ADDRESS	BIT	LABEL	DEFAULT	DESCRIPTION	REFER TO
R1408 (0580h) AIF2 EQ Gains (1)	15:11	AIF2DAC_EQ_B 1_GAIN [4:0]	0_1100	AIF2 EQ Band 1 Gain -12dB to +12dB in 1dB steps	
	10:6	AIF2DAC_EQ_B 2_GAIN [4:0]	0_1100	AIF2 EQ Band 2 Gain -12dB to +12dB in 1dB steps	
	5:1	AIF2DAC_EQ_B 3_GAIN [4:0]	0_1100	AIF2 EQ Band 3 Gain -12dB to +12dB in 1dB steps	
	0	AIF2DAC_EQ_E NA	0	Enable EQ in AIF2DAC playback path 0 = Disabled 1 = Enabled	

Register 0580h AIF2 EQ Gains (1)

REGISTER ADDRESS	BIT	LABEL	DEFAULT	DESCRIPTION	REFER TO
R1409 (0581h) AIF2 EQ Gains (2)	15:11	AIF2DAC_EQ_B 4_GAIN [4:0]	0_1100	AIF2 EQ Band 4 Gain -12dB to +12dB in 1dB steps	
	10:6	AIF2DAC_EQ_B 5_GAIN [4:0]	0_1100	AIF2 EQ Band 5 Gain -12dB to +12dB in 1dB steps	
	0	AIF2DAC_EQ_ MODE	0	AIF2 EQ Band 1 Mode 0 = Shelving filter 1 = Peak filter	

Register 0581h AIF2 EQ Gains (2)

REGISTER ADDRESS	BIT	LABEL	DEFAULT	DESCRIPTION	REFER TO
R1410 (0582h) AIF2 EQ Band 1 A	15:0	AIF2DAC_EQ_B 1_A [15:0]	0000_1111 _1100_101 0	EQ Band 1 Coefficient A	

Register 0582h AIF2 EQ Band 1 A

REGISTER ADDRESS	BIT	LABEL	DEFAULT	DESCRIPTION	REFER TO
R1411 (0583h) AIF2 EQ Band 1 B	15:0	AIF2DAC_EQ_B 1_B [15:0]	0000_0100 _0000_000 0	EQ Band 1 Coefficient B	

Register 0583h AIF2 EQ Band 1 B

REGISTER ADDRESS	BIT	LABEL	DEFAULT	DESCRIPTION	REFER TO
R1412 (0584h) AIF2 EQ Band 1 PG	15:0	AIF2DAC_EQ_B 1_PG [15:0]	0000_0000 _1101_100 0	EQ Band 1 Coefficient PG	

Register 0584h AIF2 EQ Band 1 PG

REGISTER ADDRESS	BIT	LABEL	DEFAULT	DESCRIPTION	REFER TO
R1413 (0585h) AIF2 EQ Band 2 A	15:0	AIF2DAC_EQ_B 2_A [15:0]	0001_1110 _1011_010 1	EQ Band 2 Coefficient A	

Register 0585h AIF2 EQ Band 2 A

REGISTER ADDRESS	BIT	LABEL	DEFAULT	DESCRIPTION	REFER TO
R1414 (0586h) AIF2 EQ Band 2 B	15:0	AIF2DAC_EQ_B 2_B [15:0]	1111_0001 _0100_010 1	EQ Band 2 Coefficient B	

Register 0586h AIF2 EQ Band 2 B

REGISTER ADDRESS	BIT	LABEL	DEFAULT	DESCRIPTION	REFER TO
------------------	-----	-------	---------	-------------	----------

REGISTER ADDRESS	BIT	LABEL	DEFAULT	DESCRIPTION	REFER TO
R1415 (0587h) AIF2 EQ Band 2 C	15:0	AIF2DAC_EQ_B 2_C [15:0]	0000_1011 _0111_010 1	EQ Band 2 Coefficient C	

Register 0587h AIF2 EQ Band 2 C

REGISTER ADDRESS	BIT	LABEL	DEFAULT	DESCRIPTION	REFER TO
R1416 (0588h) AIF2 EQ Band 2 PG	15:0	AIF2DAC_EQ_B 2_PG [15:0]	0000_0001 _1100_010 1	EQ Band 2 Coefficient PG	

Register 0588h AIF2 EQ Band 2 PG

REGISTER ADDRESS	BIT	LABEL	DEFAULT	DESCRIPTION	REFER TO
R1417 (0589h) AIF2 EQ Band 3 A	15:0	AIF2DAC_EQ_B 3_A [15:0]	0001_1100 _0101_100 0	EQ Band 3 Coefficient A	

Register 0589h AIF2 EQ Band 3 A

REGISTER ADDRESS	BIT	LABEL	DEFAULT	DESCRIPTION	REFER TO
R1418 (058Ah) AIF2 EQ Band 3 B	15:0	AIF2DAC_EQ_B 3_B [15:0]	1111_0011 _0111_001 1	EQ Band 3 Coefficient B	

Register 058Ah AIF2 EQ Band 3 B

REGISTER ADDRESS	BIT	LABEL	DEFAULT	DESCRIPTION	REFER TO
R1419 (058Bh) AIF2 EQ Band 3 C	15:0	AIF2DAC_EQ_B 3_C [15:0]	0000_1010 _0101_010 0	EQ Band 3 Coefficient C	

Register 058Bh AIF2 EQ Band 3 C

REGISTER ADDRESS	BIT	LABEL	DEFAULT	DESCRIPTION	REFER TO
R1420 (058Ch) AIF2 EQ Band 3 PG	15:0	AIF2DAC_EQ_B 3_PG [15:0]	0000_0101 _0101_100 0	EQ Band 3 Coefficient PG	

Register 058Ch AIF2 EQ Band 3 PG

REGISTER ADDRESS	BIT	LABEL	DEFAULT	DESCRIPTION	REFER TO
R1421 (058Dh) AIF2 EQ Band 4 A	15:0	AIF2DAC_EQ_B 4_A [15:0]	0001_0110 _1000_111 0	EQ Band 4 Coefficient A	

Register 058Dh AIF2 EQ Band 4 A

REGISTER ADDRESS	BIT	LABEL	DEFAULT	DESCRIPTION	REFER TO
R1422 (058Eh) AIF2 EQ Band 4 B	15:0	AIF2DAC_EQ_B 4_B [15:0]	1111_1000 _0010_100 1	EQ Band 4 Coefficient B	

Register 058Eh AIF2 EQ Band 4 B

REGISTER ADDRESS	BIT	LABEL	DEFAULT	DESCRIPTION	REFER TO
R1423 (058Fh) AIF2 EQ Band 4 C	15:0	AIF2DAC_EQ_B 4_C [15:0]	0000_0111 _1010_110 1	EQ Band 4 Coefficient C	

Register 058Fh AIF2 EQ Band 4 C

REGISTER ADDRESS	BIT	LABEL	DEFAULT	DESCRIPTION	REFER TO
R1424 (0590h) AIF2 EQ Band 4 PG	15:0	AIF2DAC_EQ_B 4_PG [15:0]	0001_0001 _0000_001 1	EQ Band 4 Coefficient PG	

Register 0590h AIF2 EQ Band 4 PG

REGISTER ADDRESS	BIT	LABEL	DEFAULT	DESCRIPTION	REFER TO
R1425 (0591h) AIF2 EQ Band 5 A	15:0	AIF2DAC_EQ_B 5_A [15:0]	0000_0101 _0110_010 0	EQ Band 5 Coefficient A	

Register 0591h AIF2 EQ Band 5 A

REGISTER ADDRESS	BIT	LABEL	DEFAULT	DESCRIPTION	REFER TO
R1426 (0592h) AIF2 EQ Band 5 B	15:0	AIF2DAC_EQ_B 5_B [15:0]	0000_0101 _0101_100 1	EQ Band 5 Coefficient B	

Register 0592h AIF2 EQ Band 5 B

REGISTER ADDRESS	BIT	LABEL	DEFAULT	DESCRIPTION	REFER TO
R1427 (0593h) AIF2 EQ Band 5 PG	15:0	AIF2DAC_EQ_B 5_PG [15:0]	0100_0000 _0000_000 0	EQ Band 5 Coefficient PG	

Register 0593h AIF2 EQ Band 5 PG

REGISTER ADDRESS	BIT	LABEL	DEFAULT	DESCRIPTION	REFER TO
R1536 (0600h) DAC1 Mixer Volumes	8:5	ADCR_DAC1_V OL [3:0]	0000	Sidetone STR to DAC1L and DAC1R Volume 0000 = -36dB 0001 = -33dB (3dB steps) 1011 = -3dB 1100 = 0dB	
	3:0	ADCL_DAC1_V OL [3:0]	0000	Sidetone STL to DAC1L and DAC1R Volume 0000 = -36dB 0001 = -33dB (3dB steps) 1011 = -3dB 1100 = 0dB	

Register 0600h DAC1 Mixer Volumes

REGISTER ADDRESS	BIT	LABEL	DEFAULT	DESCRIPTION	REFER TO
R1537 (0601h) DAC1 Left Mixer Routing	5	ADCR_TO_DAC 1L	0	Enable Sidetone STR to DAC1L 0 = Disabled 1 = Enabled	
	4	ADCL_TO_DAC 1L	0	Enable Sidetone STL to DAC1L 0 = Disabled 1 = Enabled	
	2	AIF2DACL_TO_ DAC1L	0	Enable AIF2 (Left) to DAC1L 0 = Disabled 1 = Enabled	
	1	AIF1DAC2L_TO_ _DAC1L	0	Enable AIF1 (Timeslot 1, Left) to DAC1L 0 = Disabled 1 = Enabled	
	0	AIF1DAC1L_TO_ _DAC1L	0	Enable AIF1 (Timeslot 0, Left) to DAC1L 0 = Disabled 1 = Enabled	

Register 0601h DAC1 Left Mixer Routing

REGISTER ADDRESS	BIT	LABEL	DEFAULT	DESCRIPTION	REFER TO
R1538 (0602h) DAC1 Right Mixer Routing	5	ADCR_TO_DAC 1R	0	Enable Sidetone STR to DAC1R 0 = Disabled 1 = Enabled	
	4	ADCL_TO_DAC 1R	0	Enable Sidetone STL to DAC1R 0 = Disabled 1 = Enabled	
	2	AIF2DACR_TO_ DAC1R	0	Enable AIF2 (Right) to DAC1R 0 = Disabled 1 = Enabled	
	1	AIF1DAC2R_TO_ _DAC1R	0	Enable AIF1 (Timeslot 1, Right) to DAC1R 0 = Disabled 1 = Enabled	
	0	AIF1DAC1R_TO_ _DAC1R	0	Enable AIF1 (Timeslot 0, Right) to DAC1R 0 = Disabled 1 = Enabled	

Register 0602h DAC1 Right Mixer Routing

REGISTER ADDRESS	BIT	LABEL	DEFAULT	DESCRIPTION	REFER TO
R1539 (0603h) DAC2 Mixer Volumes	8:5	ADCR_DAC2_V OL [3:0]	0000	Sidetone STR to DAC2L and DAC2R Volume 0000 = -36dB 0001 = -33dB (3dB steps) 1011 = -3dB 1100 = 0dB	
	3:0	ADCL_DAC2_V OL [3:0]	0000	Sidetone STL to DAC2L and DAC2R Volume 0000 = -36dB 0001 = -33dB (3dB steps) 1011 = -3dB 1100 = 0dB	

Register 0603h DAC2 Mixer Volumes

REGISTER ADDRESS	BIT	LABEL	DEFAULT	DESCRIPTION	REFER TO
R1540 (0604h) DAC2 Left Mixer Routing	5	ADCR_TO_DAC 2L	0	Enable Sidetone STR to DAC2L 0 = Disabled 1 = Enabled	
	4	ADCL_TO_DAC 2L	0	Enable Sidetone STL to DAC2L 0 = Disabled 1 = Enabled	
	2	AIF2DACL_TO_ DAC2L	0	Enable AIF2 (Left) to DAC2L 0 = Disabled 1 = Enabled	
	1	AIF1DAC2L_TO_ _DAC2L	0	Enable AIF1 (Timeslot 1, Left) to DAC2L 0 = Disabled 1 = Enabled	
	0	AIF1DAC1L_TO_ _DAC2L	0	Enable AIF1 (Timeslot 0, Left) to DAC2L 0 = Disabled 1 = Enabled	

Register 0604h DAC2 Left Mixer Routing

REGISTER ADDRESS	BIT	LABEL	DEFAULT	DESCRIPTION	REFER TO
R1541 (0605h) DAC2 Right Mixer Routing	5	ADCR_TO_DAC 2R	0	Enable Sidetone STR to DAC2R 0 = Disabled 1 = Enabled	
	4	ADCL_TO_DAC 2R	0	Enable Sidetone STL to DAC2R 0 = Disabled 1 = Enabled	
	2	AIF2DACR_TO_ DAC2R	0	Enable AIF2 (Right) to DAC2R 0 = Disabled 1 = Enabled	
	1	AIF1DAC2R_TO_ _DAC2R	0	Enable AIF1 (Timeslot 1, Right) to DAC2R 0 = Disabled 1 = Enabled	
	0	AIF1DAC1R_TO_ _DAC2R	0	Enable AIF1 (Timeslot 0, Right) to DAC2R 0 = Disabled 1 = Enabled	

Register 0605h DAC2 Right Mixer Routing

REGISTER ADDRESS	BIT	LABEL	DEFAULT	DESCRIPTION	REFER TO
R1542 (0606h) AIF1 ADC1 Left Mixer Routing	1	ADC1L_TO_AIF1ADC1L	0	Enable ADCL / DMIC1 (Left) to AIF1 (Timeslot 0, Left) output 0 = Disabled 1 = Enabled	
	0	AIF2DACL_TO_AIF1ADC1L	0	Enable AIF2 (Left) to AIF1 (Timeslot 0, Left) output 0 = Disabled 1 = Enabled	

Register 0606h AIF1 ADC1 Left Mixer Routing

REGISTER ADDRESS	BIT	LABEL	DEFAULT	DESCRIPTION	REFER TO
R1543 (0607h) AIF1 ADC1 Right Mixer Routing	1	ADC1R_TO_AIF1ADC1R	0	Enable ADCR / DMIC1 (Right) to AIF1 (Timeslot 0, Right) output 0 = Disabled 1 = Enabled	
	0	AIF2DACR_TO_AIF1ADC1R	0	Enable AIF2 (Right) to AIF1 (Timeslot 0, Right) output 0 = Disabled 1 = Enabled	

Register 0607h AIF1 ADC1 Right Mixer Routing

REGISTER ADDRESS	BIT	LABEL	DEFAULT	DESCRIPTION	REFER TO
R1544 (0608h) AIF1 ADC2 Left Mixer Routing	1	ADC2L_TO_AIF1ADC2L	0	Enable DMIC2 (Left) to AIF1 (Timeslot 1, Left) output 0 = Disabled 1 = Enabled	
	0	AIF2DACL_TO_AIF1ADC2L	0	Enable AIF2 (Left) to AIF1 (Timeslot 1, Left) output 0 = Disabled 1 = Enabled	

Register 0608h AIF1 ADC2 Left Mixer Routing

REGISTER ADDRESS	BIT	LABEL	DEFAULT	DESCRIPTION	REFER TO
R1545 (0609h) AIF1 ADC2 Right mixer Routing	1	ADC2R_TO_AIF1ADC2R	0	Enable DMIC2 (Right) to AIF1 (Timeslot 1, Right) output 0 = Disabled 1 = Enabled	
	0	AIF2DACR_TO_AIF1ADC2R	0	Enable AIF2 (Right) to AIF1 (Timeslot 1, Right) output 0 = Disabled 1 = Enabled	

Register 0609h AIF1 ADC2 Right mixer Routing

REGISTER ADDRESS	BIT	LABEL	DEFAULT	DESCRIPTION	REFER TO
R1552 (0610h) DAC1 Left Volume	9	DAC1L_MUTE	1	DAC1L Soft Mute Control 0 = DAC Un-mute 1 = DAC Mute	
	8	DAC1_VU	0	DAC1L and DAC1R Volume Update Writing a 1 to this bit will cause the DAC1L and DAC1R volume to be updated simultaneously	
	7:0	DAC1L_VOL [7:0]	1100_0000	DAC1L Digital Volume 00h = MUTE 01h = -71.625dB ... (0.375dB steps) C0h = 0dB ... (0.375dB steps) E0h = 12dB FFh = 12dB	

Register 0610h DAC1 Left Volume

REGISTER ADDRESS	BIT	LABEL	DEFAULT	DESCRIPTION	REFER TO
R1553 (0611h) DAC1 Right Volume	9	DAC1R_MUTE	1	DAC1R Soft Mute Control 0 = DAC Un-mute 1 = DAC Mute	
	8	DAC1_VU	0	DAC1L and DAC1R Volume Update Writing a 1 to this bit will cause the DAC1L and DAC1R volume to be updated simultaneously	
	7:0	DAC1R_VOL [7:0]	1100_0000	DAC1R Digital Volume 00h = MUTE 01h = -71.625dB ... (0.375dB steps) C0h = 0dB ... (0.375dB steps) E0h = 12dB FFh = 12dB	

Register 0611h DAC1 Right Volume

REGISTER ADDRESS	BIT	LABEL	DEFAULT	DESCRIPTION	REFER TO
R1554 (0612h) DAC2 Left Volume	9	DAC2L_MUTE	1	DAC2L Soft Mute Control 0 = DAC Un-mute 1 = DAC Mute	
	8	DAC2_VU	0	DAC2L and DAC2R Volume Update Writing a 1 to this bit will cause the DAC2L and DAC2R volume to be updated simultaneously	
	7:0	DAC2L_VOL [7:0]	1100_0000	DAC2L Digital Volume 00h = MUTE 01h = -71.625dB ... (0.375dB steps) C0h = 0dB ... (0.375dB steps) E0h = 12dB FFh = 12dB	

Register 0612h DAC2 Left Volume

REGISTER ADDRESS	BIT	LABEL	DEFAULT	DESCRIPTION	REFER TO
R1555 (0613h) DAC2 Right Volume	9	DAC2R_MUTE	1	DAC2R Soft Mute Control 0 = DAC Un-mute 1 = DAC Mute	
	8	DAC2_VU	0	DAC2L and DAC2R Volume Update Writing a 1 to this bit will cause the DAC2L and DAC2R volume to be updated simultaneously	
	7:0	DAC2R_VOL [7:0]	1100_0000	DAC2R Digital Volume 00h = MUTE 01h = -71.625dB ... (0.375dB steps) C0h = 0dB ... (0.375dB steps) E0h = 12dB FFh = 12dB	

Register 0613h DAC2 Right Volume

REGISTER ADDRESS	BIT	LABEL	DEFAULT	DESCRIPTION	REFER TO
R1556 (0614h) DAC Softmute	1	DAC_SOFTMUTE EMODE	0	DAC Unmute Ramp select 0 = Disabling soft-mute (DAC [1/2] [L/R]_MUTE=0) will cause the DAC volume to change immediately to DAC [1/2] [L/R]_VOL settings 1 = Disabling soft-mute (DAC [1/2] [L/R]_MUTE=0) will cause the DAC volume to ramp up gradually to the DAC [1/2] [L/R]_VOL settings	
	0	DAC_MUTERATE	0	DAC Soft Mute Ramp Rate 0 = Fast ramp (fs/2, maximum ramp time is 10.7ms at fs=48k) 1 = Slow ramp (fs/32, maximum ramp time is 171ms at fs=48k) (Note: ramp rate scales with sample rate.)	

Register 0614h DAC Softmute

REGISTER ADDRESS	BIT	LABEL	DEFAULT	DESCRIPTION	REFER TO
R1568 (0620h) Oversampling	1	ADC_OSR128	1	ADC / Digital Microphone Oversample Rate Select 0 = Low Power 1 = High Performance	
	0	DAC_OSR128	0	DAC Oversample Rate Select 0 = Low Power 1 = High Performance	

Register 0620h Oversampling

REGISTER ADDRESS	BIT	LABEL	DEFAULT	DESCRIPTION	REFER TO
R1569 (0621h) Sidetone	9:7	ST_HPF_CUT [2:0]	000	Sidetone HPF cut-off frequency (relative to 44.1kHz sample rate) 000 = 2.7kHz 001 = 1.35kHz 010 = 675Hz 011 = 370Hz 100 = 180Hz 101 = 90Hz 110 = 45Hz 111 = Reserved Note - the cut-off frequencies scale with the Digital Mixing (SYSCLK) clocking rate. The quoted figures apply to 44.1kHz sample rate.	
	6	ST_HPF	0	Digital Sidetone HPF Select 0 = Disabled 1 = Enabled	
	1	STR_SEL	0	Select source for sidetone STR path 0 = ADCR / DMICDAT1 (Right) 1 = DMICDAT2 (Right)	
	0	STL_SEL	0	Select source for sidetone STL path 0 = ADCL / DMICDAT1 (Left) 1 = DMICDAT2 (Left)	

Register 0621h Sidetone

REGISTER ADDRESS	BIT	LABEL	DEFAULT	DESCRIPTION	REFER TO
R1792 (0700h) GPIO 1	15	GP1_DIR	1	GPIO1 Pin Direction 0 = Output 1 = Input	
	14	GP1_PU	0	GPIO1 Pull-Up Enable 0 = Disabled 1 = Enabled	
	13	GP1_PD	0	GPIO1 Pull-Down Enable 0 = Disabled 1 = Enabled	
	10	GP1_POL	0	GPIO1 Polarity Select 0 = Non-inverted (Active High) 1 = Inverted (Active Low)	
	9	GP1_OP_CFG	0	GPIO1 Output Configuration 0 = CMOS 1 = Open Drain	
	8	GP1_DB	1	GPIO1 Input De-bounce 0 = Disabled 1 = Enabled	
	6	GP1_LVL	0	GPIO1 level. Write to this bit to set a GPIO output. Read from this bit to read GPIO input level. For output functions only, when GP1_POL is set, the register contains the opposite logic level to the external pin.	

REGISTER ADDRESS	BIT	LABEL	DEFAULT	DESCRIPTION	REFER TO
	4:0	GP1_FN [4:0]	0_0000	GPIO1 Pin Function 00h = ADCLRCLK1 01h = GPIO 02h = Reserved 03h = IRQ 04h = Temperature (Shutdown) status 05h = MICDET status 06h = Reserved 07h = Reserved 08h = Reserved 09h = FLL1 Lock 0Ah = FLL2 Lock 0Bh = SRC1 Lock 0Ch = SRC2 Lock 0Dh = AIF1 DRC1 Signal Detect 0Eh = AIF1 DRC2 Signal Detect 0Fh = AIF2 DRC Signal Detect 10h = Write Sequencer Status 11h = FIFO Error 12h = OPCLK Clock output 13h = Temperature (Warning) status 14h = DC Servo Done 15h = FLL1 Clock output 16h = FLL2 Clock output 17h to 1Fh = Reserved	

Register 0700h GPIO 1

REGISTER ADDRESS	BIT	LABEL	DEFAULT	DESCRIPTION	REFER TO
R1793 (0701h) Pull Control (MCLK2)	14	MCLK2_PU	0	MCLK2 Pull-up enable 0 = Disabled 1 = Enabled	
	13	MCLK2_PD	1	MCLK2 Pull-down enable 0 = Disabled 1 = Enabled	

Register 0701h Pull Control (MCLK2)

REGISTER ADDRESS	BIT	LABEL	DEFAULT	DESCRIPTION	REFER TO
R1794 (0702h) Pull Control (BCLK2)	14	BCLK2_PU	0	BCLK2 Pull-up enable 0 = Disabled 1 = Enabled	
	13	BCLK2_PD	1	BCLK2 Pull-down enable 0 = Disabled 1 = Enabled	

Register 0702h Pull Control (BCLK2)

REGISTER ADDRESS	BIT	LABEL	DEFAULT	DESCRIPTION	REFER TO
R1795 (0703h) Pull Control (DACLRCLK2)	14	DACLRCLK2_PU	0	DACLRCLK2 Pull-up enable 0 = Disabled 1 = Enabled	
	13	DACLRCLK2_PD	1	DACLRCLK2 Pull-down enable 0 = Disabled 1 = Enabled	

Register 0703h Pull Control (DACLRCLK2)

REGISTER ADDRESS	BIT	LABEL	DEFAULT	DESCRIPTION	REFER TO
R1796 (0704h) Pull Control (DACDAT2)	14	DACDAT2_PU	0	DACDAT2 Pull-up enable 0 = Disabled 1 = Enabled	
	13	DACDAT2_PD	1	DACDAT2 Pull-down enable 0 = Disabled 1 = Enabled	

Register 0704h Pull Control (DACDAT2)

REGISTER ADDRESS	BIT	LABEL	DEFAULT	DESCRIPTION	REFER TO
R1797 (0705h) GPIO 6	15	GP6_DIR	1	GPIO6 Pin Direction 0 = Output 1 = Input	
	14	GP6_PU	0	GPIO6 Pull-Up Enable 0 = Disabled 1 = Enabled	
	13	GP6_PD	1	GPIO6 Pull-Down Enable 0 = Disabled 1 = Enabled	
	10	GP6_POL	0	GPIO6 Polarity Select 0 = Non-inverted (Active High) 1 = Inverted (Active Low)	
	9	GP6_OP_CFG	0	GPIO6 Output Configuration 0 = CMOS 1 = Open Drain	
	8	GP6_DB	1	GPIO6 Input De-bounce 0 = Disabled 1 = Enabled	
	6	GP6_LVL	0	GPIO6 level. Write to this bit to set a GPIO output. Read from this bit to read GPIO input level. For output functions only, when GP6_POL is set, the register contains the opposite logic level to the external pin.	
	4:0	GP6_FN [4:0]	0_0001	GPIO6 Pin Function 00h = ADCLRCLK2 01h = GPIO 02h = Reserved 03h = IRQ 04h = Temperature (Shutdown) status 05h = MICDET status 06h = Reserved 07h = Reserved	

REGISTER ADDRESS	BIT	LABEL	DEFAULT	DESCRIPTION	REFER TO
				08h = Reserved 09h = FLL1 Lock 0Ah = FLL2 Lock 0Bh = SRC1 Lock 0Ch = SRC2 Lock 0Dh = AIF1 DRC1 Signal Detect 0Eh = AIF1 DRC2 Signal Detect 0Fh = AIF2 DRC Signal Detect 10h = Write Sequencer Status 11h = FIFO Error 12h = OPCLK Clock output 13h = Temperature (Warning) status 14h = DC Servo Done 15h = FLL1 Clock output 16h = FLL2 Clock output 17h to 1Fh = Reserved	

Register 0705h GPIO 6

REGISTER ADDRESS	BIT	LABEL	DEFAULT	DESCRIPTION	REFER TO
R1799 (0707h) GPIO 8	15	GP8_DIR	1	GPIO8 Pin Direction 0 = Output 1 = Input	
	14	GP8_PU	0	GPIO8 Pull-Up Enable 0 = Disabled 1 = Enabled	
	13	GP8_PD	1	GPIO8 Pull-Down Enable 0 = Disabled 1 = Enabled	
	10	GP8_POL	0	GPIO8 Polarity Select 0 = Non-inverted (Active High) 1 = Inverted (Active Low)	
	9	GP8_OP_CFG	0	GPIO8 Output Configuration 0 = CMOS 1 = Open Drain	
	8	GP8_DB	1	GPIO8 Input De-bounce 0 = Disabled 1 = Enabled	
	6	GP8_LVL	0	GPIO8 level. Write to this bit to set a GPIO output. Read from this bit to read GPIO input level. For output functions only, when GP8_POL is set, the register contains the opposite logic level to the external pin.	
	4:0	GP8_FN [4:0]	0_0001	GPIO8 Pin Function 00h = DACDAT3 01h = GPIO 02h = Reserved 03h = IRQ 04h = Temperature (Shutdown) status 05h = MICDET status 06h = Reserved 07h = Reserved 08h = Reserved 09h = FLL1 Lock	

REGISTER ADDRESS	BIT	LABEL	DEFAULT	DESCRIPTION	REFER TO
				0Ah = FLL2 Lock 0Bh = SRC1 Lock 0Ch = SRC2 Lock 0Dh = AIF1 DRC1 Signal Detect 0Eh = AIF1 DRC2 Signal Detect 0Fh = AIF2 DRC Signal Detect 10h = Write Sequencer Status 11h = FIFO Error 12h = OPCLK Clock output 13h = Temperature (Warning) status 14h = DC Servo Done 15h = FLL1 Clock output 16h = FLL2 Clock output 17h to 1Fh = Reserved	

Register 0707h GPIO 8

REGISTER ADDRESS	BIT	LABEL	DEFAULT	DESCRIPTION	REFER TO
R1800 (0708h) GPIO 9	15	GP9_DIR	1	GPIO9 Pin Direction 0 = Output 1 = Input	
	14	GP9_PU	0	GPIO9 Pull-Up Enable 0 = Disabled 1 = Enabled	
	13	GP9_PD	1	GPIO9 Pull-Down Enable 0 = Disabled 1 = Enabled	
	10	GP9_POL	0	GPIO9 Polarity Select 0 = Non-inverted (Active High) 1 = Inverted (Active Low)	
	9	GP9_OP_CFG	0	GPIO9 Output Configuration 0 = CMOS 1 = Open Drain	
	8	GP9_DB	1	GPIO9 Input De-bounce 0 = Disabled 1 = Enabled	
	6	GP9_LVL	0	GPIO9 level. Write to this bit to set a GPIO output. Read from this bit to read GPIO input level. For output functions only, when GP9_POL is set, the register contains the opposite logic level to the external pin.	
	4:0	GP9_FN [4:0]	0_0001	GPIO9 Pin Function 00h = ADCDAT3 01h = GPIO 02h = Reserved 03h = IRQ 04h = Temperature (Shutdown) status 05h = MICDET status 06h = Reserved 07h = Reserved 08h = Reserved 09h = FLL1 Lock 0Ah = FLL2 Lock	

REGISTER ADDRESS	BIT	LABEL	DEFAULT	DESCRIPTION	REFER TO
				0Bh = SRC1 Lock 0Ch = SRC2 Lock 0Dh = AIF1 DRC1 Signal Detect 0Eh = AIF1 DRC2 Signal Detect 0Fh = AIF2 DRC Signal Detect 10h = Write Sequencer Status 11h = FIFO Error 12h = OPCLK Clock output 13h = Temperature (Warning) status 14h = DC Servo Done 15h = FLL1 Clock output 16h = FLL2 Clock output 17h to 1Fh = Reserved	

Register 0708h GPIO 9

REGISTER ADDRESS	BIT	LABEL	DEFAULT	DESCRIPTION	REFER TO
R1801 (0709h) GPIO 10	15	GP10_DIR	1	GPIO10 Pin Direction 0 = Output 1 = Input	
	14	GP10_PU	0	GPIO10 Pull-Up Enable 0 = Disabled 1 = Enabled	
	13	GP10_PD	1	GPIO10 Pull-Down Enable 0 = Disabled 1 = Enabled	
	10	GP10_POL	0	GPIO10 Polarity Select 0 = Non-inverted (Active High) 1 = Inverted (Active Low)	
	9	GP10_OP_CFG	0	GPIO10 Output Configuration 0 = CMOS 1 = Open Drain	
	8	GP10_DB	1	GPIO10 Input De-bounce 0 = Disabled 1 = Enabled	
	6	GP10_LVL	0	GPIO10 level. Write to this bit to set a GPIO output. Read from this bit to read GPIO input level. For output functions only, when GP10_POL is set, the register contains the opposite logic level to the external pin.	
	4:0	GP10_FN [4:0]	0_0001	GPIO10 Pin Function 00h = LRCLK3 01h = GPIO 02h = Reserved 03h = IRQ 04h = Temperature (Shutdown) status 05h = MICDET status 06h = Reserved 07h = Reserved 08h = Reserved 09h = FLL1 Lock 0Ah = FLL2 Lock 0Bh = SRC1 Lock 0Ch = SRC2 Lock	

REGISTER ADDRESS	BIT	LABEL	DEFAULT	DESCRIPTION	REFER TO
				0Dh = AIF1 DRC1 Signal Detect 0Eh = AIF1 DRC2 Signal Detect 0Fh = AIF2 DRC Signal Detect 10h = Write Sequencer Status 11h = FIFO Error 12h = OPCLK Clock output 13h = Temperature (Warning) status 14h = DC Servo Done 15h = FLL1 Clock output 16h = FLL2 Clock output 17h to 1Fh = Reserved	

Register 0709h GPIO 10

REGISTER ADDRESS	BIT	LABEL	DEFAULT	DESCRIPTION	REFER TO
R1802 (070Ah) GPIO 11	15	GP11_DIR	1	GPIO11 Pin Direction 0 = Output 1 = Input	
	14	GP11_PU	0	GPIO11 Pull-Up Enable 0 = Disabled 1 = Enabled	
	13	GP11_PD	1	GPIO11 Pull-Down Enable 0 = Disabled 1 = Enabled	
	10	GP11_POL	0	GPIO11 Polarity Select 0 = Non-inverted (Active High) 1 = Inverted (Active Low)	
	9	GP11_OP_CFG	0	GPIO11 Output Configuration 0 = CMOS 1 = Open Drain	
	8	GP11_DB	1	GPIO11 Input De-bounce 0 = Disabled 1 = Enabled	
	6	GP11_LVL	0	GPIO11 level. Write to this bit to set a GPIO output. Read from this bit to read GPIO input level. For output functions only, when GP11_POL is set, the register contains the opposite logic level to the external pin.	
	4:0	GP11_FN [4:0]	0_0001	GPIO11 Pin Function 00h = BCLK3 01h = GPIO 02h = Reserved 03h = IRQ 04h = Temperature (Shutdown) status 05h = MICDET status 06h = Reserved 07h = Reserved 08h = Reserved 09h = FLL1 Lock 0Ah = FLL2 Lock 0Bh = SRC1 Lock 0Ch = SRC2 Lock 0Dh = AIF1 DRC1 Signal Detect	

REGISTER ADDRESS	BIT	LABEL	DEFAULT	DESCRIPTION	REFER TO
				0Eh = AIF1 DRC2 Signal Detect 0Fh = AIF2 DRC Signal Detect 10h = Write Sequencer Status 11h = FIFO Error 12h = OPCLK Clock output 13h = Temperature (Warning) status 14h = DC Servo Done 15h = FLL1 Clock output 16h = FLL2 Clock output 17h to 1Fh = Reserved	

Register 070Ah GPIO 11

REGISTER ADDRESS	BIT	LABEL	DEFAULT	DESCRIPTION	REFER TO
R1824 (0720h) Pull Control (1)	11	DMICDAT2_PU	0	DMICDAT2 Pull-Up enable 0 = Disabled 1 = Enabled	
	10	DMICDAT2_PD	0	DMICDAT2 Pull-Down enable 0 = Disabled 1 = Enabled	
	9	DMICDAT1_PU	0	DMICDAT1 Pull-Up enable 0 = Disabled 1 = Enabled	
	8	DMICDAT1_PD	0	DMICDAT1 Pull-Down enable 0 = Disabled 1 = Enabled	
	7	MCLK1_PU	0	MCLK1 Pull-up enable 0 = Disabled 1 = Enabled	
	6	MCLK1_PD	0	MCLK1 Pull-down enable 0 = Disabled 1 = Enabled	
	5	DACDAT1_PU	0	DACDAT1 Pull-up enable 0 = Disabled 1 = Enabled	
	4	DACDAT1_PD	0	DACDAT1 Pull-down enable 0 = Disabled 1 = Enabled	
	3	DACLRCLK1_PU	0	LRCLK1 Pull-up enable 0 = Disabled 1 = Enabled	
	2	DACLRCLK1_PD	0	LRCLK1 Pull-down enable 0 = Disabled 1 = Enabled	
	1	BCLK1_PU	0	BCLK1 Pull-up enable 0 = Disabled 1 = Enabled	
	0	BCLK1_PD	0	BCLK1 Pull-down enable 0 = Disabled 1 = Enabled	

Register 0720h Pull Control (1)

REGISTER ADDRESS	BIT	LABEL	DEFAULT	DESCRIPTION	REFER TO
R1825 (0721h) Pull Control (2)	8	ADDR_PD	1	ADDR Pull-down enable 0 = Disabled 1 = Enabled	
	6	LDO2ENA_PD	1	LDO2ENA Pull-down enable 0 = Disabled 1 = Enabled	
	4	LDO1ENA_PD	1	LDO1ENA Pull-down enable 0 = Disabled 1 = Enabled	
	1	SPKMODE_PU	1	SPKMODE Pull-up enable 0 = Disabled 1 = Enabled	

Register 0721h Pull Control (2)

REGISTER ADDRESS	BIT	LABEL	DEFAULT	DESCRIPTION	REFER TO
R1840 (0730h) Interrupt Status 1	10	GP11_EINT	0	GPIO11 Interrupt (Rising and falling edge triggered) Note: Cleared when a '1' is written.	
	9	GP10_EINT	0	GPIO10 Interrupt (Rising and falling edge triggered) Note: Cleared when a '1' is written.	
	8	GP9_EINT	0	GPIO9 Interrupt (Rising and falling edge triggered) Note: Cleared when a '1' is written.	
	7	GP8_EINT	0	GPIO8 Interrupt (Rising and falling edge triggered) Note: Cleared when a '1' is written.	
	5	GP6_EINT	0	GPIO6 Interrupt (Rising and falling edge triggered) Note: Cleared when a '1' is written.	
	0	GP1_EINT	0	GPIO1 Interrupt (Rising and falling edge triggered) Note: Cleared when a '1' is written.	

Register 0730h Interrupt Status 1

REGISTER ADDRESS	BIT	LABEL	DEFAULT	DESCRIPTION	REFER TO
R1841 (0731h) Interrupt Status 2	15	TEMP_WARN_EINT	0	Temperature Warning Interrupt (Rising and falling edge triggered) Note: Cleared when a '1' is written.	
	14	DCS_DONE_EINT	0	DC Servo Interrupt (Rising edge triggered) Note: Cleared when a '1' is written.	
	13	WSEQ_DONE_EINT	0	Write Sequencer Interrupt (Rising edge triggered) Note: Cleared when a '1' is written.	
	12	FIFOS_ERR_EINT	0	Digital Core FIFO Error Interrupt (Rising edge triggered) Note: Cleared when a '1' is written.	

REGISTER ADDRESS	BIT	LABEL	DEFAULT	DESCRIPTION	REFER TO
	11	AIF2DRC_SIG_DET_EINT	0	AIF2 DRC Activity Detect Interrupt (Rising edge triggered) Note: Cleared when a '1' is written.	
	10	AIF1DRC2_SIG_DET_EINT	0	AIF1 DRC2 (Timeslot 1) Activity Detect Interrupt (Rising edge triggered) Note: Cleared when a '1' is written.	
	9	AIF1DRC1_SIG_DET_EINT	0	AIF1 DRC1 (Timeslot 0) Activity Detect Interrupt (Rising edge triggered) Note: Cleared when a '1' is written.	
	8	SRC2_LOCK_INTERRUPT	0	SRC2 Lock Interrupt (Rising and falling edge triggered) Note: Cleared when a '1' is written.	
	7	SRC1_LOCK_INTERRUPT	0	SRC1 Lock Interrupt (Rising and falling edge triggered) Note: Cleared when a '1' is written.	
	6	FLL2_LOCK_INTERRUPT	0	FLL2 Lock Interrupt (Rising and falling edge triggered) Note: Cleared when a '1' is written.	
	5	FLL1_LOCK_INTERRUPT	0	FLL1 Lock Interrupt (Rising and falling edge triggered) Note: Cleared when a '1' is written.	
	1	MICD_EINT	0	Microphone Detection Interrupt (Rising and falling edge triggered) Note: Cleared when a '1' is written.	
	0	TEMP_SHUTDOWN_INTERRUPT	0	Temperature Shutdown Interrupt (Rising and falling edge triggered) Note: Cleared when a '1' is written.	

Register 0731h Interrupt Status 2

REGISTER ADDRESS	BIT	LABEL	DEFAULT	DESCRIPTION	REFER TO
R1842 (0732h) Interrupt Raw Status 2	15	TEMP_WARN_STS	0	Temperature Warning status 0 = Temperature is below warning level 1 = Temperature is above warning level	
	14	DCS_DONE_STS	0	DC Servo status 0 = DC Servo not complete 1 = DC Servo complete	
	13	WSEQ_DONE_STS	0	Write Sequencer status 0 = Sequencer Busy (sequence in progress) 1 = Sequencer Idle	
	12	FIFOS_ERR_STS	0	Digital Core FIFO Error status 0 = Normal operation 1 = FIFO Error	
	11	AIF2DRC_SIG_DET_STS	0	AIF2 DRC Signal Detect status 0 = Signal threshold not exceeded 1 = Signal threshold exceeded	
	10	AIF1DRC2_SIG_DET_STS	0	AIF1 DRC2 (Timeslot 1) Signal Detect status 0 = Signal threshold not exceeded 1 = Signal threshold exceeded	
	9	AIF1DRC1_SIG_DET_STS	0	AIF1 DRC1 (Timeslot 0) Signal Detect status 0 = Signal threshold not exceeded 1 = Signal threshold exceeded	

REGISTER ADDRESS	BIT	LABEL	DEFAULT	DESCRIPTION	REFER TO
	8	SRC2_LOCK_STS	0	SRC2 Lock status 0 = Not locked 1 = Locked	
	7	SRC1_LOCK_STS	0	SRC1 Lock status 0 = Not locked 1 = Locked	
	6	FLL2_LOCK_STS	0	FLL2 Lock status 0 = Not locked 1 = Locked	
	5	FLL1_LOCK_STS	0	FLL1 Lock status 0 = Not locked 1 = Locked	
	0	TEMP_SHUT_STS	0	Temperature Shutdown status 0 = Temperature is below shutdown level 1 = Temperature is above shutdown level	

Register 0732h Interrupt Raw Status 2

REGISTER ADDRESS	BIT	LABEL	DEFAULT	DESCRIPTION	REFER TO
R1848 (0738h) Interrupt Status 1 Mask	10	IM_GP11_EINT	1	GPIO11 Interrupt mask. 0 = Do not mask interrupt. 1 = Mask interrupt.	
	9	IM_GP10_EINT	1	GPIO10 Interrupt mask. 0 = Do not mask interrupt. 1 = Mask interrupt.	
	8	IM_GP9_EINT	1	GPIO9 Interrupt mask. 0 = Do not mask interrupt. 1 = Mask interrupt.	
	7	IM_GP8_EINT	1	GPIO8 Interrupt mask. 0 = Do not mask interrupt. 1 = Mask interrupt.	
	5	IM_GP6_EINT	1	GPIO6 Interrupt mask. 0 = Do not mask interrupt. 1 = Mask interrupt.	
	0	IM_GP1_EINT	1	GPIO1 Interrupt mask. 0 = Do not mask interrupt. 1 = Mask interrupt.	

Register 0738h Interrupt Status 1 Mask

REGISTER ADDRESS	BIT	LABEL	DEFAULT	DESCRIPTION	REFER TO
R1849 (0739h) Interrupt Status 2 Mask	15	IM_TEMP_WARN_EINT	1	Temperature Warning Interrupt mask. 0 = Do not mask interrupt. 1 = Mask interrupt.	
	14	IM_DCS_DONE_EINT	1	DC Servo Interrupt mask. 0 = Do not mask interrupt. 1 = Mask interrupt.	
	13	IM_WSEQ_DONE_EINT	1	Write Sequencer Interrupt mask. 0 = Do not mask interrupt. 1 = Mask interrupt.	
	12	IM_FIFOS_ERR	1	Digital Core FIFO Error Interrupt mask.	

REGISTER ADDRESS	BIT	LABEL	DEFAULT	DESCRIPTION	REFER TO
		_EINT		0 = Do not mask interrupt. 1 = Mask interrupt.	
	11	IM_AIF2DRC2_SIG_DET_EINT	1	AIF2 DRC Activity Detect Interrupt mask. 0 = Do not mask interrupt. 1 = Mask interrupt.	
	10	IM_AIF1DRC2_SIG_DET_EINT	1	AIF1 DRC2 (Timeslot 1) Activity Detect Interrupt mask. 0 = Do not mask interrupt. 1 = Mask interrupt.	
	9	IM_AIF1DRC1_SIG_DET_EINT	1	AIF1 DRC1 (Timeslot 0) Activity Detect Interrupt mask. 0 = Do not mask interrupt. 1 = Mask interrupt.	
	8	IM_SRC2_LOCK_EINT	1	SRC2 Lock Interrupt mask. 0 = Do not mask interrupt. 1 = Mask interrupt.	
	7	IM_SRC1_LOCK_EINT	1	SRC1 Lock Interrupt mask. 0 = Do not mask interrupt. 1 = Mask interrupt.	
	6	IM_FLL2_LOCK_EINT	1	FLL2 Lock Interrupt mask. 0 = Do not mask interrupt. 1 = Mask interrupt.	
	5	IM_FLL1_LOCK_EINT	1	FLL1 Lock Interrupt mask. 0 = Do not mask interrupt. 1 = Mask interrupt.	
	1	IM_MICD_EINT	1	Microphone Detection Interrupt mask. 0 = Do not mask interrupt. 1 = Mask interrupt.	
	0	IM_TEMP_SHUT_EINT	1	Temperature Shutdown Interrupt mask. 0 = Do not mask interrupt. 1 = Mask interrupt.	

Register 0739h Interrupt Status 2 Mask

REGISTER ADDRESS	BIT	LABEL	DEFAULT	DESCRIPTION	REFER TO
R1856 (0740h) Interrupt Control	0	IM_IRQ	0	IRQ Output Interrupt mask. 0 = Do not mask interrupt. 1 = Mask interrupt.	

Register 0740h Interrupt Control

REGISTER ADDRESS	BIT	LABEL	DEFAULT	DESCRIPTION	REFER TO
R1864 (0748h) IRQ Debounce	5	TEMP_WARN_DB	1	Temperature Warning de-bounce 0 = Disabled 1 = Enabled	
	0	TEMP_SHUT_DB	1	Thermal shutdown de-bounce 0 = Disabled 1 = Enabled	

Register 0748h IRQ Debounce

REGISTER ADDRESS	BIT	LABEL	DEFAULT	DESCRIPTION	REFER TO
R2304 (0900h) DSP2_Program	0	DSP2_ENA	0	DSP2 Audio Processor Enable. 0 = Disabled 1 = Enabled This bit must be set before the MBC is enabled. It must remain set whenever the MBC is enabled.	

Register 0900h DSP2_Program

REGISTER ADDRESS	BIT	LABEL	DEFAULT	DESCRIPTION	REFER TO
R2305 (0901h) DSP2_Config	5:4	MBC_SEL [1:0]	00	MBC Signal Path select 00 = AIF1DAC1 input path (AIF1, Timeslot 0) 01 = AIF1DAC2 input path (AIF1, Timeslot 1) 10 = AIF2DAC input path 11 = Reserved	
	0	MBC_ENA	0	MBC Enable 0 = Disabled 1 = Enabled	

Register 0901h DSP2_Config

REGISTER ADDRESS	BIT	LABEL	DEFAULT	DESCRIPTION	REFER TO
R2573 (0A0Dh) DSP2_ExecControl	2	DSP2_STOP	0	Stop the DSP2 audio processor Writing a 1 to this bit will cause the DSP2 processor to stop processing audio data	
	1	DSP2_RUNR	0	Start the DSP2 audio processor Writing a 1 to this bit will cause the DSP2 processor to start processing audio data	

Register 0A0Dh DSP2_ExecControl

APPLICATIONS INFORMATION

RECOMMENDED EXTERNAL COMPONENTS

AUDIO INPUT PATHS

The WM8958 provides 8 analogue audio inputs. Each of these inputs is referenced to the internal DC reference, VMID. A DC blocking capacitor is required for each input pin used in the target application. The choice of capacitor is determined by the filter that is formed between that capacitor and the input impedance of the input pin. The circuit is illustrated in Figure 84.

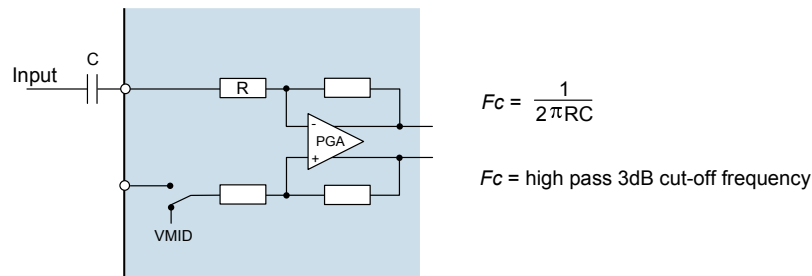

Figure 84 Audio Input Path DC Blocking Capacitor

If the input impedance is known, and the cut-off frequency is known, then the minimum capacitor value may be derived easily. However, it can be seen from the representation in Figure 84 that the input impedance is not fixed in all applications but can vary with gain and boost amplifier settings.

The PGA input resistance for every gain setting is detailed in Table 152.

IN1L_VOL[4:0], IN2L_VOL[4:0], IN1R_VOL[4:0], IN2R_VOL[4:0]	VOLUME (dB)	INPUT RESISTANCE (kΩ)	
		SINGLE-ENDED MODE	DIFFERENTIAL MODE
00000	-16.5	58	52.5
00001	-15.0	56.9	50.6
00010	-13.5	55.6	48.6
00011	-12.0	54.1	46.4
00100	-10.5	52.5	44.1
00101	-9.0	50.7	41.5
00110	-7.5	48.6	38.9
00111	-6.0	46.5	36.2
01000	-4.5	44.1	33.4
01001	-3.0	41.6	30.6
01010	-1.5	38.9	27.8
01011	0	36.2	25.1
01100	+1.5	33.4	22.5
01101	+3.0	30.6	20.0
01110	+4.5	27.8	17.7
01111	+6.0	25.1	15.6
10000	+7.5	22.5	13.6
10001	+9.0	20.1	11.9
10010	+10.5	17.8	10.3
10011	+12.0	15.6	8.9
10100	+13.5	13.7	7.6

IN1L_VOL[4:0], IN2L_VOL[4:0], IN1R_VOL[4:0], IN2R_VOL[4:0]	VOLUME (dB)	INPUT RESISTANCE (k Ω)	
		SINGLE-ENDED MODE	DIFFERENTIAL MODE
10101	+15.0	11.9	6.5
10110	+16.5	10.3	5.6
10111	+18.0	8.9	4.8
11000	+19.5	7.7	4.1
11001	+21.0	6.6	3.5
11010	+22.5	5.6	2.9
11011	+24.0	4.8	2.5
11100	+25.5	4.1	2.1
11101	+27.0	3.5	1.8
11110	+28.5	2.9	1.5
11111	+30.0	2.5	1.3

Table 152 PGA Input Pin Resistance

The appropriate input capacitor may be selected using the PGA input resistance data provided in Table 152, depending on the required PGA gain setting(s).

The choice of capacitor for a 20Hz cut-off frequency is shown in Table 153 for a selection of typical input impedance conditions.

INPUT IMPEDANCE	MINIMUM CAPACITANCE FOR 20HZ PASS BAND
2k Ω	4 μ F
15k Ω	0.5 μ F
30k Ω	0.27 μ F
60k Ω	0.13 μ F

Table 153 Audio Input DC Blocking Capacitors

Using the figures in Table 153, it follows that a 1 μ F capacitance for all input connections will give good results in most cases. Tantalum electrolytic capacitors are particularly suitable as they offer high stability in a small package size.

Ceramic equivalents are a cost effective alternative to the superior tantalum packages, but care must be taken to ensure the desired capacitance is maintained at the AVDD1 operating voltage. Also, ceramic capacitors may show microphonic effects, where vibrations and mechanical conditions give rise to electrical signals. This is particularly problematic for microphone input paths where a large signal gain is required.

A single capacitor is required for a line input or single-ended microphone connection. In the case of a differential microphone connection, a DC blocking capacitor is required on both input pins.

HEADPHONE OUTPUT PATH

The headphone output on WM8958 is ground referenced and therefore does not require the large, expensive capacitors necessary for VMID reference solutions. For best audio performance, it is recommended to connect a zobel network to the audio output pins. This network should comprise of a 100nF capacitor and 20ohm resistor in series with each other (see "Analogue Outputs" section). These components have the effect of dampening high frequency oscillations or instabilities that can arise outside the audio band under certain conditions. Possible sources of these instabilities include the inductive load of a headphone coil or an active load in the form of an external line amplifier.

EARPIECE DRIVER OUTPUT PATH

The earpiece driver on HPOUT2P and HPOUT2N is designed as a 32ohm BTL speaker driver. The outputs are referenced to the internal DC reference VMID, but direct connection to the speaker is possible because of the BTL configuration. There is no requirement for DC blocking capacitors.

LINE OUTPUT PATHS

The WM8958 provides four line outputs (LINEOUT1P, LINEOUT1N, LINEOUT2P and LINEOUT2N). Each of these outputs is referenced to the internal DC reference, VMID. In any case where a line output is used in a single-ended configuration (i.e. referenced to AGND), a DC blocking capacitor will be required in order to remove the DC bias. In the case where a pair of line outputs is configured as a BTL differential pair, then the DC blocking capacitor should be omitted.

The choice of capacitor is determined from the filter that is formed between the capacitor and the load impedance – see Figure 85.

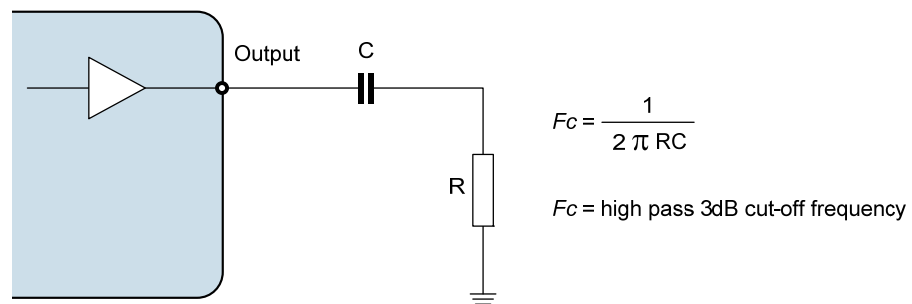

Figure 85 Line Output Path Components

LOAD IMPEDANCE	MINIMUM CAPACITANCE FOR 20HZ PASS BAND
10k Ω	0.8 μ F
47k Ω	0.17 μ F

Table 154 Line Output Frequency Cut-Off

Using the figures in Table 154, it follows that that a 1 μ F capacitance would be a suitable choice for a line load. Tantalum electrolytic capacitors are again particularly suitable but ceramic equivalents are a cost effective alternative. Care must be taken to ensure the desired capacitance is maintained at the appropriate operating voltage.

POWER SUPPLY DECOUPLING

Electrical coupling exists particularly in digital logic systems where switching in one sub-system causes fluctuations on the power supply. This effect occurs because the inductance of the power supply acts in opposition to the changes in current flow that are caused by the logic switching. The resultant variations (or 'spikes') in the power supply voltage can cause malfunctions and unintentional behavior in other components. A decoupling (or 'bypass') capacitor can be used as an energy storage component which will provide power to the decoupled circuit for the duration of these power supply variations, protecting it from malfunctions that could otherwise arise.

Coupling also occurs in a lower frequency form when ripple is present on the power supply rail caused by changes in the load current or by limitations of the power supply regulation method. In audio components such as the WM8958, these variations can alter the performance of the signal path, leading to degradation in signal quality. A decoupling (or 'bypass') capacitor can be used to filter these effects, by presenting the ripple voltage with a low impedance path that does not affect the circuit to be decoupled.

These coupling effects are addressed by placing a capacitor between the supply rail and the corresponding ground reference. In the case of systems comprising multiple power supply rails, decoupling should be provided on each rail.

The recommended power supply decoupling capacitors for WM8958 are listed below in Table 155.

POWER SUPPLY	DECOUPLING CAPACITOR
LDO1VDD, DBVDD1, DBVDD2, DBVDD3, AVDD2	0.1 μ F ceramic (see Note)
SPKVDD1, SPKVDD2	4.7 μ F ceramic
AVDD1	4.7 μ F ceramic
DCVDD	2.2 μ F ceramic
CPVDD	4.7 μ F ceramic
VMIDC	4.7 μ F ceramic
VREFC	1.0 μ F ceramic

Table 155 Power Supply Decoupling Capacitors

Note: 0.1 μ F is required with 4.7 μ F a guide to the total required power rail capacitance, including that at the regulator output.

All decoupling capacitors should be placed as close as possible to the WM8958 device. The connection between AGND, the AVDD1 decoupling capacitor and the main system ground should be made at a single point as close as possible to the AGND ball of the WM8958.

The VMID capacitor is not, technically, a decoupling capacitor. However, it does serve a similar purpose in filtering noise on the VMID reference. The connection between AGND, the VMID decoupling capacitor and the main system ground should be made at a single point as close as possible to the AGND ball of the WM8958.

Due to the wide tolerance of many types of ceramic capacitors, care must be taken to ensure that the selected components provide the required capacitance across the required temperature and voltage ranges in the intended application. For most applications, the use of ceramic capacitors with capacitor dielectric X5R is recommended.

CHARGE PUMP COMPONENTS

A fly-back capacitor is required between the CPCA and CPCB pins. The required capacitance is 2.2 μ F at 2V.

A decoupling capacitor is required on CPVOUTP and CPVOUTN; the recommended value is 2.2 μ F at 2V.

The positioning of the Charge Pump capacitors is important, particularly the fly-back capacitor. These capacitors should be placed as close as possible to the WM8958.

Due to the wide tolerance of many types of ceramic capacitors, care must be taken to ensure that the selected components provide the required capacitance across the required temperature and voltage ranges in the intended application. For most applications, the use of ceramic capacitors with capacitor dielectric X5R is recommended.

MICROPHONE BIAS CIRCUIT

The WM8958 is designed to interface easily with up to four analogue microphones. These may be connected in single-ended or differential configurations, as illustrated in Figure 86. The single-ended method allows greater capability for the connection of multiple audio sources simultaneously, whilst the differential method provides better performance due to its rejection of common-mode noise.

In either configuration, the analogue microphone requires a bias current (electret condenser microphones) or voltage supply (silicon microphones), which can be provided by MICBIAS1 or MICBIAS2.

A current-limiting resistor is required when using an electret condenser microphone (ECM). The resistance should be chosen according to the minimum operating impedance of the microphone and MICBIAS voltage so that the maximum bias current of the WM8958 is not exceeded. Wolfson recommends a 2.2k Ω current limiting resistor as it provides compatibility with a wide range of microphone models.

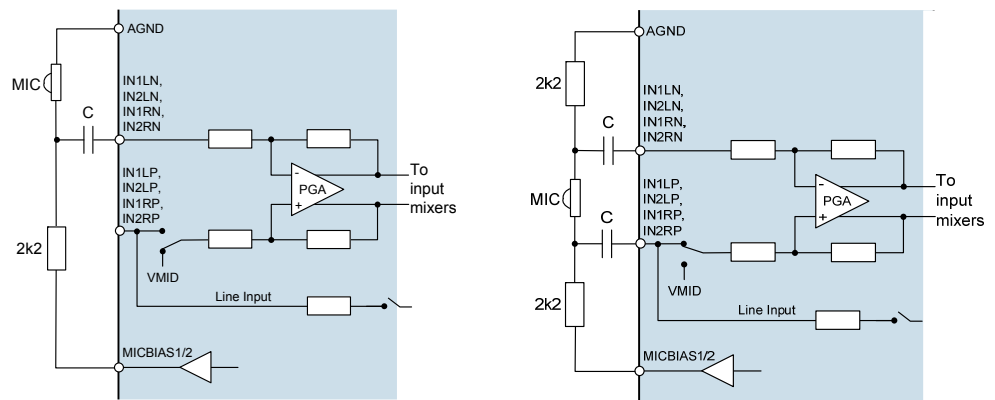

Figure 86 Single-Ended and Differential Analogue Microphone Connections

The WM8958 also supports up to four digital microphone inputs. The MICBIAS1 generator is suitable for use as a low noise supply for digital microphones, as shown in Figure 87.

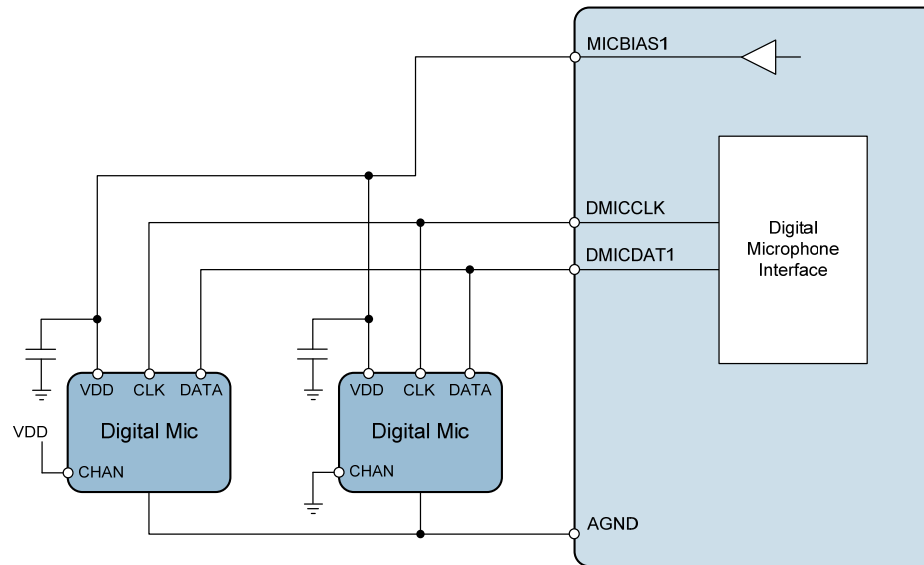

Figure 87 Digital Microphone Connection

The MICBIAS generators can each operate as a voltage regulator or in bypass mode. See “Analogue Input Signal Path” for details of the MICBIAS generators.

In Regulator mode, the MICBIAS regulators are designed to operate without external decoupling capacitors. It is important that parasitic capacitances on the MICBIAS1 or MICBIAS2 pins do not exceed the specified limit in Regulator mode (see “Electrical Characteristics”).

If the capacitive load on MICBIAS1 or MICBIAS2 exceeds the specified limit (eg. due to a decoupling capacitor or long PCB trace), then the respective generator must be configured in Bypass mode.

The maximum output current is noted in the “Electrical Characteristics”. This limit must be observed on each MICBIAS output, especially if more than one microphone is connected to a single MICBIAS pin. Note that the maximum output current differs between Regulator mode and Bypass mode. The MICBIAS output voltage can be adjusted using register control in Regulator mode.

EXTERNAL ACCESSORY DETECTION COMPONENTS

The accessory detection circuit measures the impedance of an external load connected to the MICDET pin.

This function uses the MICBIAS2 output as a reference, as shown in Figure 88. Note that the WM8958 will automatically enable MICBIAS2 when required in order to perform the detection function.

The WM8958 can detect the presence of a typical microphone and up to 7 push-buttons, using the components shown. When the microphone detection circuit is enabled, then each of the push-buttons shown will cause a different bit within the MICD_LVL register to be set.

The microphone detect function is specifically designed to detect a video accessory (typical 75Ω) load if required. A measured external impedance of 75Ω will cause the MICD_LVL [4] bit to be set.

The measured impedance is reported using the MICD_STS and MICD_LVL bits.
 When no accessory or push-button is detected, the MICD_STS bit is set to 0.
 When MICD_STS = 1, then one of the MICD_LVL bits is set to indicate the measured impedance.
 The applicable MICD_LVL bit for each push-button is noted below.
 Detection of the microphone alone (no push-buttons closed) is indicated in MICD_LVL[7].

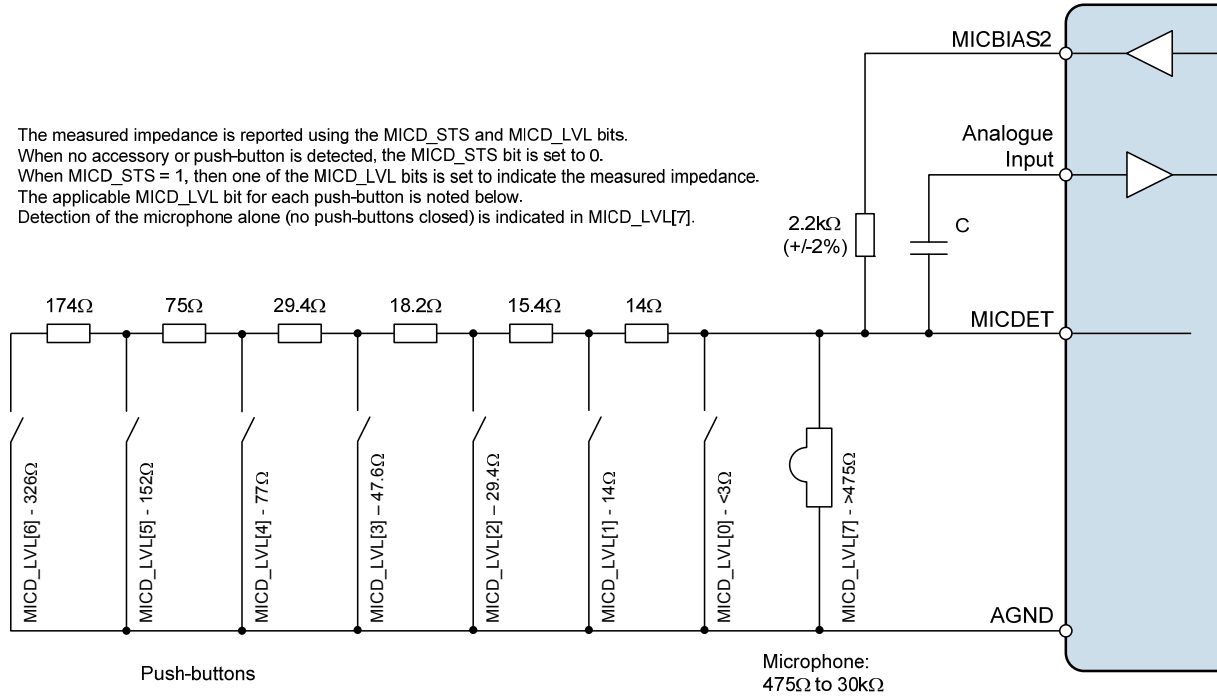

Figure 88 External Accessory Detect Connection

CLASS D SPEAKER CONNECTIONS

The WM8958 incorporates two Class D/AB speaker drivers. By default, the speaker drivers operate in Class D mode, which offers high amplifier efficiency at large signal levels. As the Class D output is a pulse width modulated signal, the choice of speakers and tracking of signals is critical for ensuring good performance and reducing EMI in this mode.

The efficiency of the speaker drivers is affected by the series resistance between the WM8958 and the speaker (e.g. PCB track loss and inductor ESR) as shown in Figure 89. This resistance should be as low as possible to maximise efficiency.

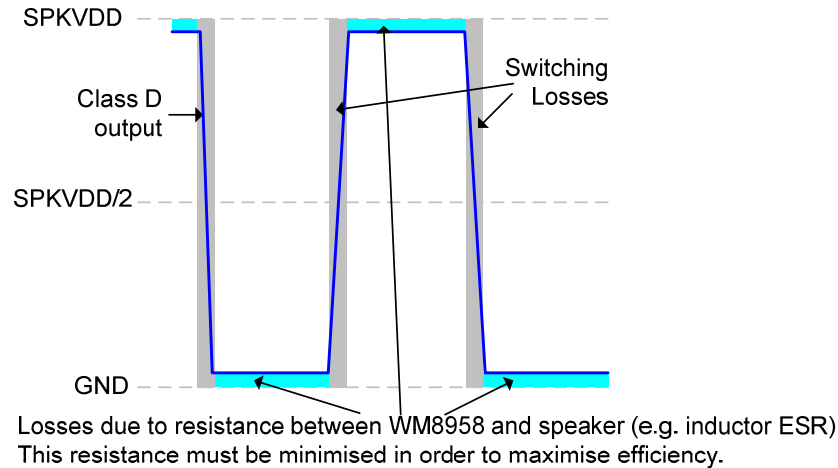

Figure 89 Speaker Connection Losses

The Class D output requires external filtering in order to recreate the audio signal. This may be implemented using a 2nd order LC or 1st order RC filter, or else may be achieved by using a loudspeaker whose internal inductance provides the required filter response. An LC or RC filter should be used if the loudspeaker characteristics are unknown or unsuitable, or if the length of the loudspeaker connection is likely to lead to EMI problems.

In applications where it is necessary to provide Class D filter components, a 2nd order LC filter is the recommended solution as it provides more attenuation at higher frequencies and minimises power dissipated in the filter when compared to a first order RC filter (lower ESR). This maximises both rejection of unwanted switching frequencies and overall speaker efficiency. A suitable implementation is illustrated in Figure 90.

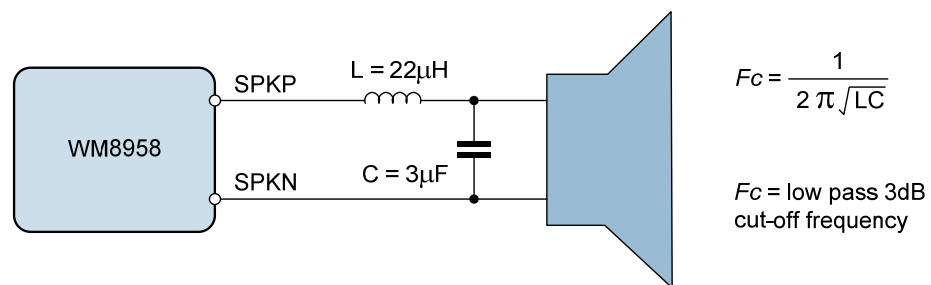

Figure 90 Class D Output Filter Components

A simple equivalent circuit of a loudspeaker consists of a serially connected resistor and inductor, as shown in Figure 91. This circuit provides a low pass filter for the speaker output. If the loudspeaker characteristics are suitable, then the loudspeaker itself can be used in place of the filter components described earlier. This is known as 'filterless' operation.

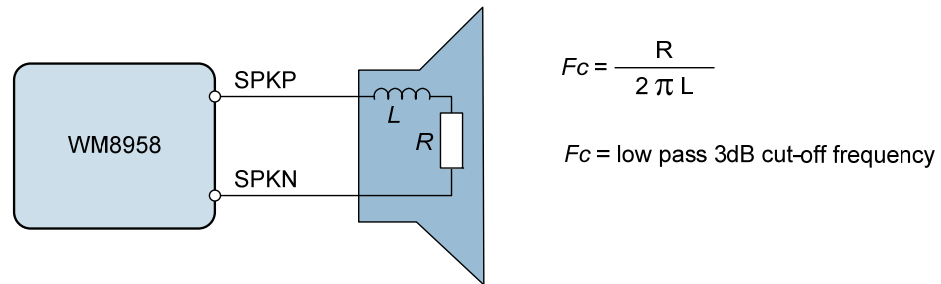

Figure 91 Speaker Equivalent Circuit for Filterless Operation

For filterless Class D operation, it is important to ensure that a speaker with suitable inductance is chosen. For example, if we know the speaker impedance is 8Ω and the desired cut-off frequency is 20kHz, then the optimum speaker inductance may be calculated as:

$$L = \frac{R}{2 \pi F_c} = \frac{8\Omega}{2 \pi * 20\text{kHz}} = 64\mu\text{H}$$

8Ω loudspeakers typically have an inductance in the range $20\mu\text{H}$ to $100\mu\text{H}$, however, it should be noted that a loudspeaker inductance will not be constant across the relevant frequencies for Class D operation (up to and beyond the Class D switching frequency). Care should be taken to ensure that the cut-off frequency of the loudspeaker's filtering is low enough to suppress the high frequency energy of the Class D switching and, in so doing, to prevent speaker damage. The Class D outputs of the WM8958 operate at much higher frequencies than is recommended for most speakers and it must be ensured that the cut-off frequency is low enough to protect the speaker.

RECOMMENDED EXTERNAL COMPONENTS DIAGRAM

Figure 92 provides a summary of recommended external components for WM8958. Note that this diagram does not include any components that are specific to the end application e.g. it does not include filtering on the speaker outputs (assume filterless Class D operation), RF decoupling, or RF filtering for pins which connect to the external world i.e. headphone or speaker outputs.

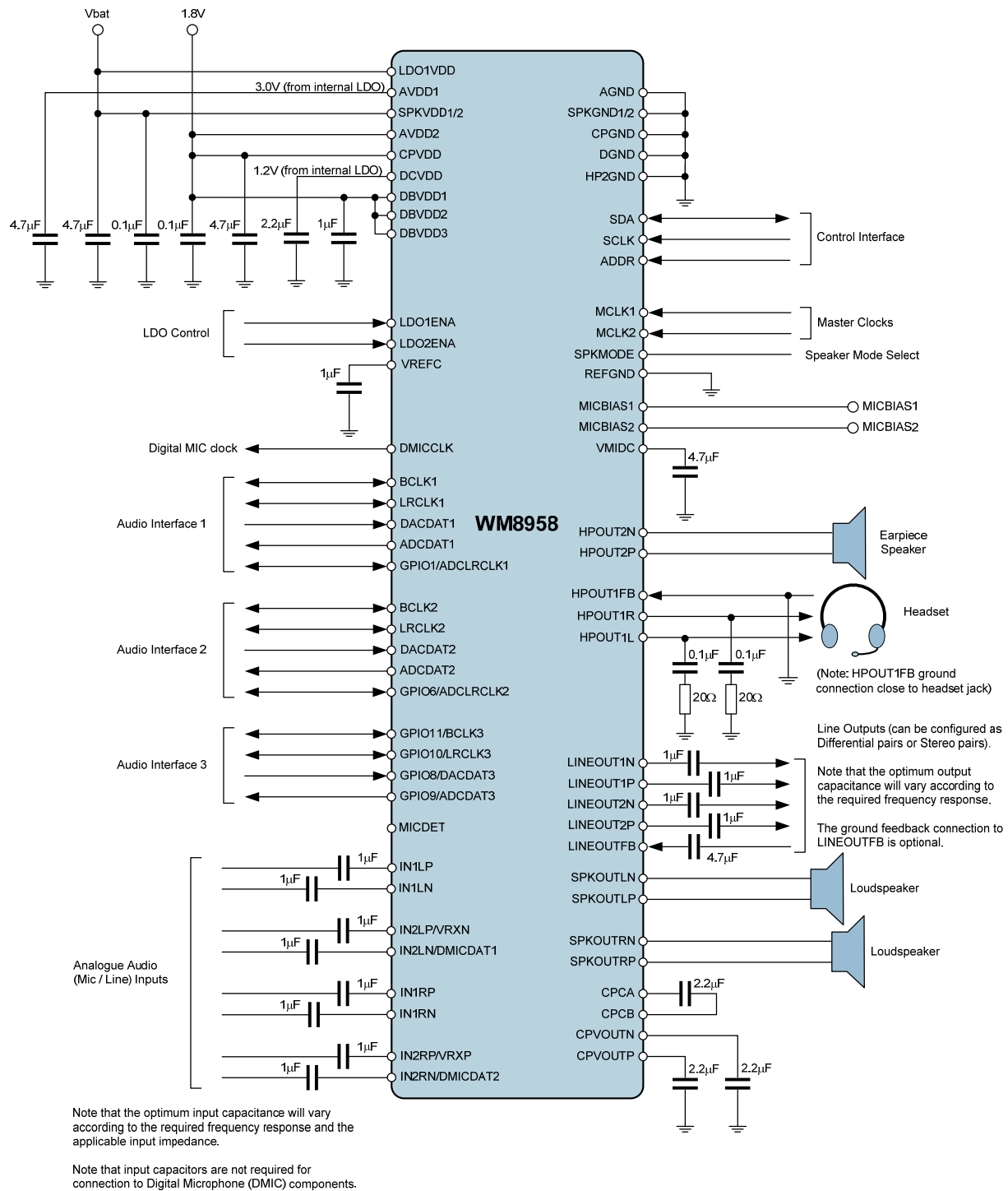

Figure 92 Recommended External Components Diagram

DIGITAL AUDIO INTERFACE CLOCKING CONFIGURATIONS

The WM8958 provides 3 digital audio interfaces and supports many different clocking configurations. The asynchronous sample rate converter enables more than one digital audio interface to be supported simultaneously, even when there is no synchronisation between these interfaces. In a typical application, this enables audio mixing between a multimedia applications processor and a baseband voice call processor, for example.

The AIF1 and AIF2 audio interfaces can be configured in Master or Slave modes, and can also support defined combinations of mixed sample rates. In all applications, it is important that the system clocking configuration is correctly designed. Incorrect clock configurations will lead to audible clicks arising from dropped or repeated audio samples; this is caused by the inherent tolerances of multiple asynchronous system clocks.

To ensure reliable clocking of the audio interface functions, it is a requirement that, for each audio interface, the external interface clocks (eg. BCLK, LRCLK) are derived from the same clock source as the respective AIF clock (AIFnCLK).

In AIF Master mode, the external BCLK and LRCLK signals are generated by the WM8958 and synchronisation of these signals with AIFnCLK is guaranteed. In this case, clocking of the AIF is derived from the MCLK1 or MCLK2 inputs, either directly or via one of the Frequency Locked Loop (FLL) circuits.

In AIF Slave mode, the external BCLK and LRCLK signals are generated by another device, as inputs to the WM8958. In this case, it must be ensured that the respective AIF clock is generated from a source that is synchronised to the external BCLK and LRCLK inputs. In a typical Slave mode application, the BCLK input is selected as the clock reference, using the FLL to perform frequency shifting. It is also possible to use the MCLK1 or MCLK2 inputs, but only if the selected clock is synchronised externally to the BCLK and LRCLK inputs.

The valid AIF clocking configurations are listed in Table 156 for AIF Master and AIF Slave modes.

AUDIO INTERFACE MODE	CLOCKING CONFIGURATION
AIF Master Mode	AIFnCLK_SRC selects FLL1 or FLL2 as AIFnCLK source; FLLn_REFCLK_SRC selects MCLK1 or MCLK2 as FLLn source.
	AIFnCLK_SRC selects MCLK1 or MCLK2 as AIFnCLK source.
AIF Slave Mode	AIFnCLK_SRC selects FLL1 or FLL2 as AIFnCLK source; FLLn_REFCLK_SRC selects BCLKn as FLLn source.
	AIFnCLK_SRC selects MCLK1 or MCLK2 as AIFnCLK source, provided MCLK is externally synchronised to the BCLKn input.
	AIFnCLK_SRC selects FLL1 or FLL2 as AIFnCLK source; FLLn_REFCLK_SRC selects MCLK1 or MCLK2 as FLLn source, provided MCLK is externally synchronised to the BCLKn input.

Table 156 Audio Interface Clocking Configurations

In each case, the AIFnCLK frequency must be a valid ratio to the LRCLKn frequency; the supported clocking ratios are defined by the AIFnCLK_RATE register.

The valid AIF clocking configurations are illustrated in Figure 93 to Figure 97 below. Note that, where MCLK1 is illustrated as the clock source, it is equally possible to select MCLK2 as the clock source. Similarly, in cases where FLL1 is illustrated, it is equally possible to select the FLL2.

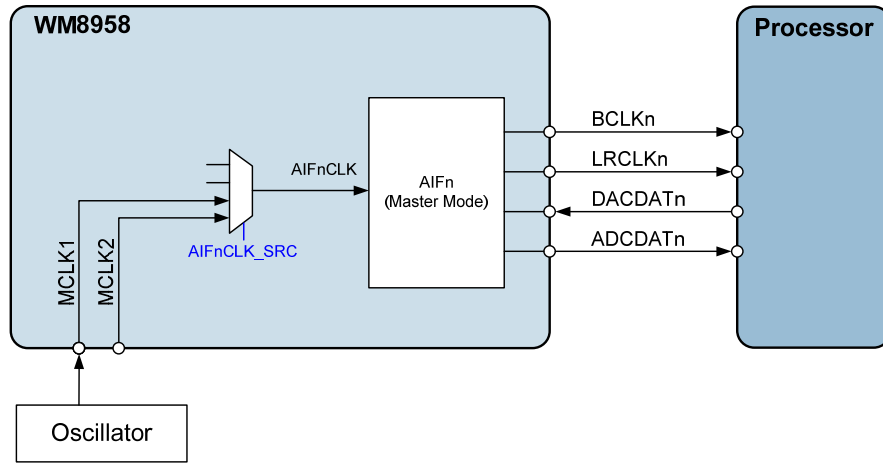

Figure 93 AIF Master Mode, using MCLK as reference

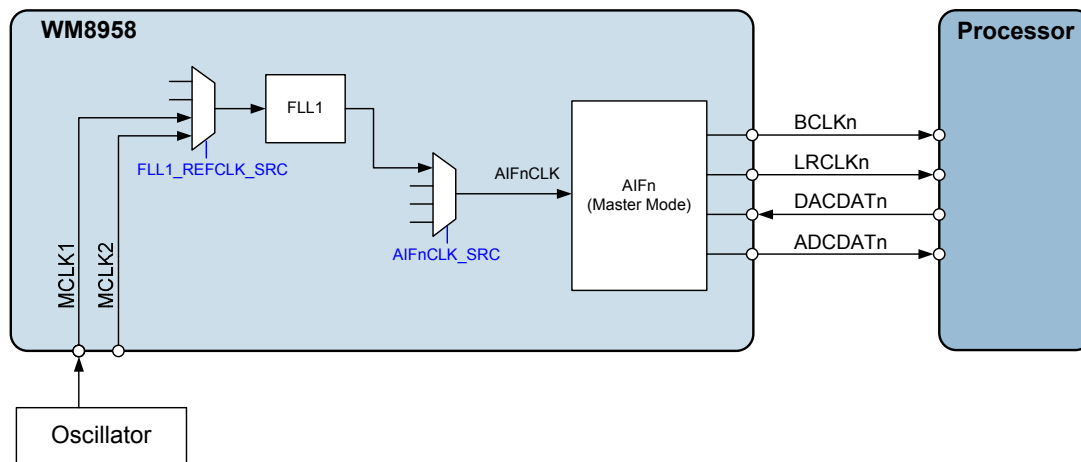

Figure 94 AIF Master Mode, using MCLK and FLL as reference

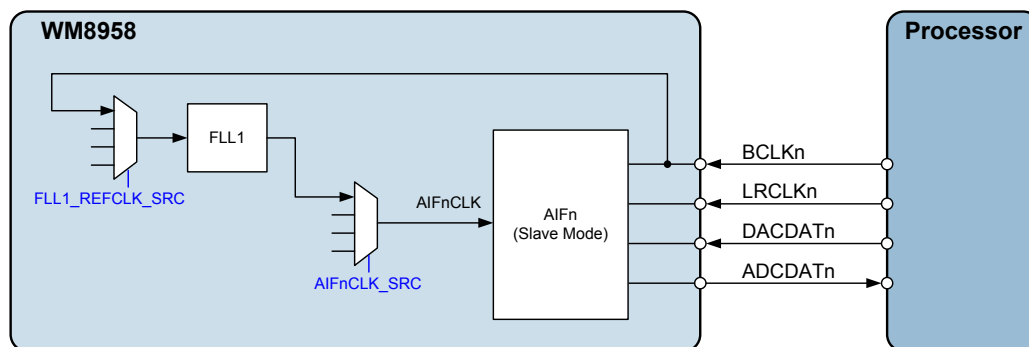

Figure 95 AIF Slave Mode, using BCLK and FLL as reference

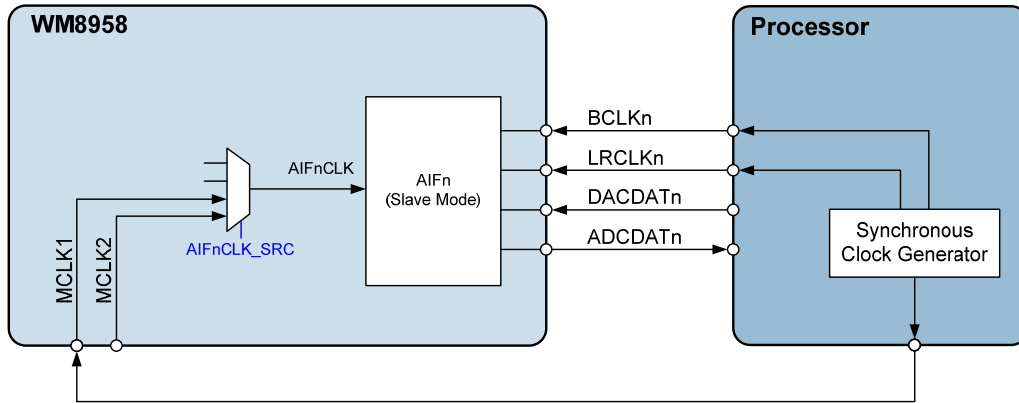

Figure 96 AIF Slave Mode, using MCLK as reference

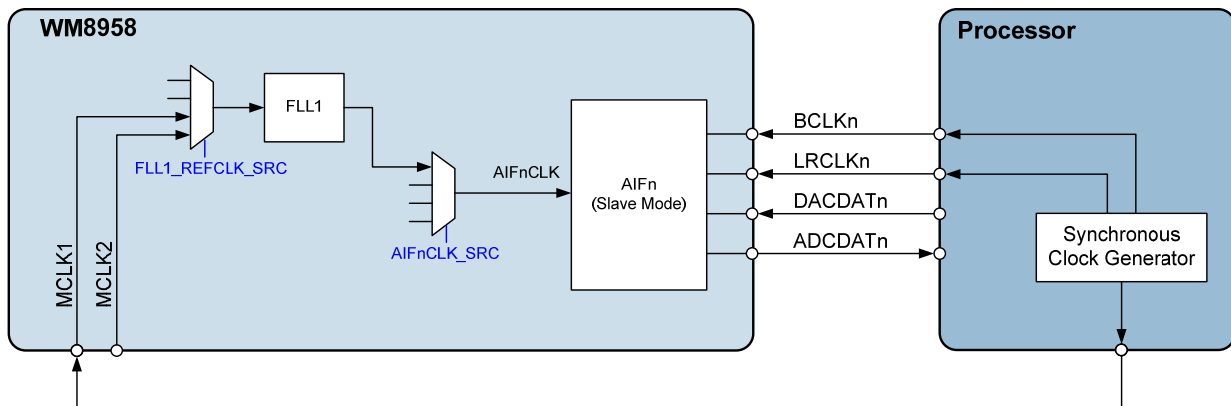

Figure 97 AIF Slave Mode, using MCLK and FLL as reference

PCB LAYOUT CONSIDERATIONS

Poor PCB layout will degrade the performance and be a contributory factor in EMI, ground bounce and resistive voltage losses. All external components should be placed as close to the WM8958 device as possible, with current loop areas kept as small as possible. Specific factors relating to Class D loudspeaker connection are detailed below.

CLASS D LOUDSPEAKER CONNECTION

Long, exposed PCB tracks or connection wires will emit EMI. The distance between the WM8958 and the loudspeaker should therefore be kept as short as possible. Where speakers are connected to the PCB via a cable form, it is recommended that a shielded twisted pair cable is used. The shield should be connected to the main system, with care taken to ensure ground loops are avoided.

Further reduction in EMI can be achieved using PCB ground (or VDD) planes and also by using passive LC components to filter the Class D switching waveform. When passive filtering is used, low ESR components should be chosen in order to minimise the series resistance between the WM8958 and the speaker, maximising the power efficiency.

LC passive filtering will usually be effective at reducing EMI at frequencies up to around 30MHz. To reduce emissions at higher frequencies, ferrite beads can also be used. These should be positioned as close to the device as possible.

These techniques for EMI reduction are illustrated in Figure 98.

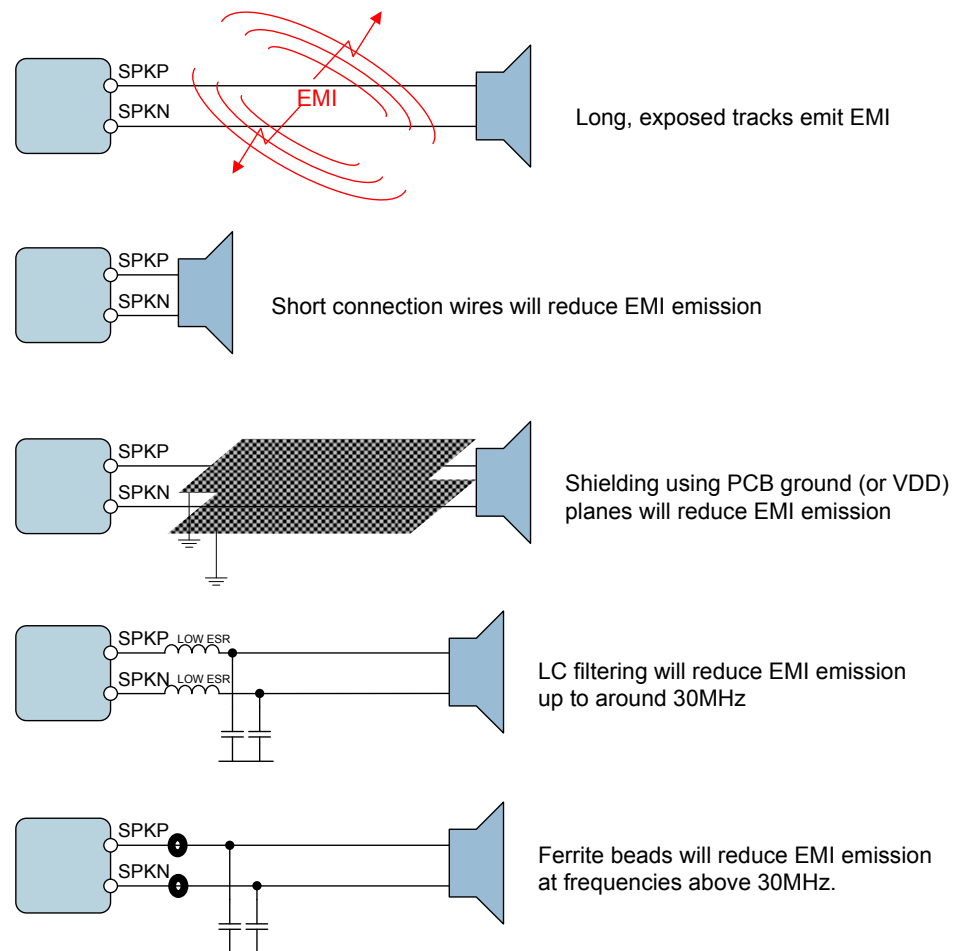
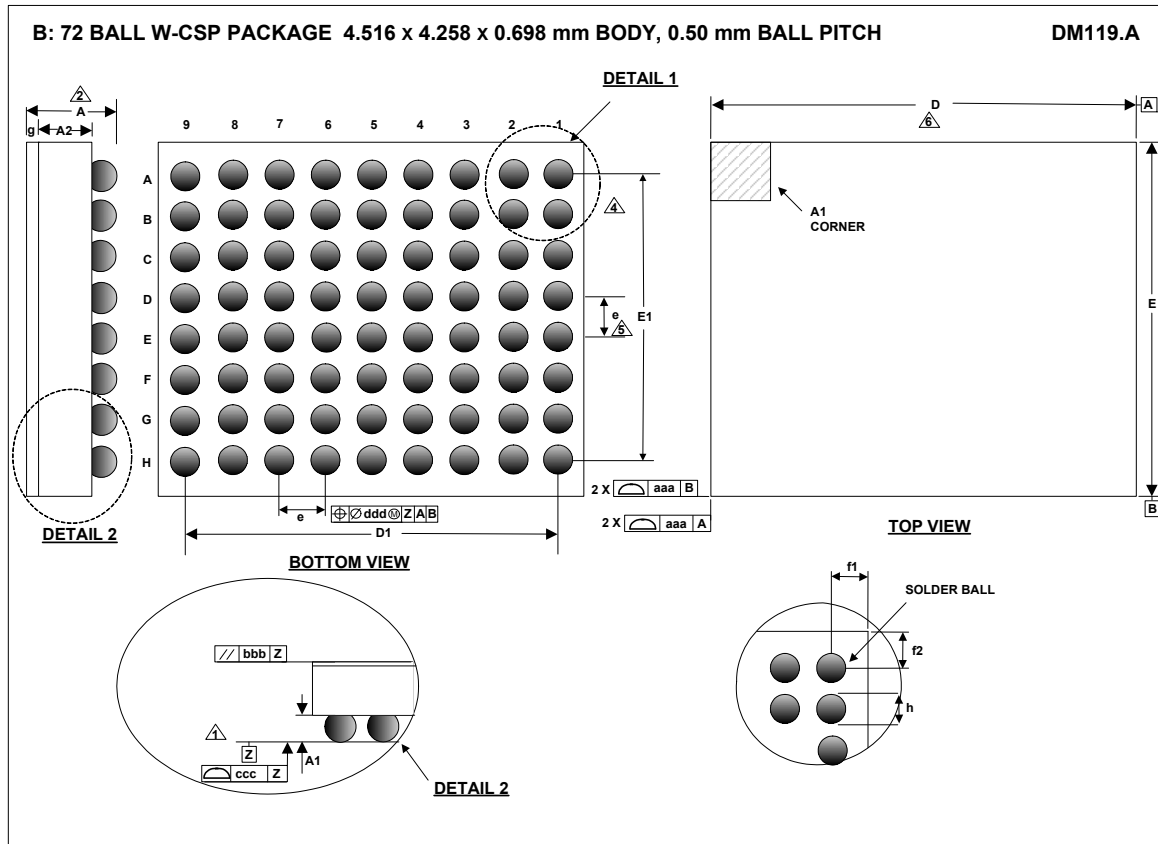

Figure 98 EMI Reduction Techniques

PACKAGE DIMENSIONS



Symbols	Dimensions (mm)			NOTE
	MIN	NOM	MAX	
A	0.658	0.698	0.738	
A1	0.206	0.242	0.278	
A2	0.418	0.434	0.450	
D	4.491	4.516	4.541	
D1		4.00 BSC		
E	4.233	4.258	4.283	
E1		3.50 BSC		
e		0.50 BSC		5
f1	0.246			8
f2	0.367			9
g		0.022		
h	0.264	0.314	0.364	
aaa		0.025		
bbb		0.060		
ccc		0.030		
ddd		0.015		

- NOTES:
1. PRIMARY DATUM -Z- AND SEATING PLANE ARE DEFINED BY THE SPHERICAL CROWNS OF THE SOLDER BALLS.
 2. THIS DIMENSION INCLUDES STAND-OFF HEIGHT 'A1' AND BACKSIDE COATING.
 3. A1 CORNER IS IDENTIFIED BY INKLASER MARK ON TOP PACKAGE.
 4. BILATERAL TOLERANCE ZONE IS APPLIED TO EACH SIDE OF THE PACKAGE BODY.
 5. 'e' REPRESENTS THE BASIC SOLDER BALL GRID PITCH.
 6. THIS DRAWING IS SUBJECT TO CHANGE WITHOUT NOTICE.
 7. FOLLOWS JEDEC DESIGN GUIDE MO-214-C.
 8. f1 = NOMINAL DISTANCE OF BALL CENTRE TO DIE EDGE X AXIS (AS PER POD) – APPLICABLE TO ALL CORNERS OF DIE.
 9. f2 = NOMINAL DISTANCE OF DIE CENTRE TO DIE EDGE IN Y AXIS (AS PER POD) – APPLICABLE TO ALL CORNERS OF DIE.

IMPORTANT NOTICE

Wolfson Microelectronics plc ("Wolfson") products and services are sold subject to Wolfson's terms and conditions of sale, delivery and payment supplied at the time of order acknowledgement.

Wolfson warrants performance of its products to the specifications in effect at the date of shipment. Wolfson reserves the right to make changes to its products and specifications or to discontinue any product or service without notice. Customers should therefore obtain the latest version of relevant information from Wolfson to verify that the information is current.

Testing and other quality control techniques are utilised to the extent Wolfson deems necessary to support its warranty. Specific testing of all parameters of each device is not necessarily performed unless required by law or regulation.

In order to minimise risks associated with customer applications, the customer must use adequate design and operating safeguards to minimise inherent or procedural hazards. Wolfson is not liable for applications assistance or customer product design. The customer is solely responsible for its selection and use of Wolfson products. Wolfson is not liable for such selection or use nor for use of any circuitry other than circuitry entirely embodied in a Wolfson product.

Wolfson's products are not intended for use in life support systems, appliances, nuclear systems or systems where malfunction can reasonably be expected to result in personal injury, death or severe property or environmental damage. Any use of products by the customer for such purposes is at the customer's own risk.

Wolfson does not grant any licence (express or implied) under any patent right, copyright, mask work right or other intellectual property right of Wolfson covering or relating to any combination, machine, or process in which its products or services might be or are used. Any provision or publication of any third party's products or services does not constitute Wolfson's approval, licence, warranty or endorsement thereof. Any third party trade marks contained in this document belong to the respective third party owner.

Reproduction of information from Wolfson datasheets is permissible only if reproduction is without alteration and is accompanied by all associated copyright, proprietary and other notices (including this notice) and conditions. Wolfson is not liable for any unauthorised alteration of such information or for any reliance placed thereon.

Any representations made, warranties given, and/or liabilities accepted by any person which differ from those contained in this datasheet or in Wolfson's standard terms and conditions of sale, delivery and payment are made, given and/or accepted at that person's own risk. Wolfson is not liable for any such representations, warranties or liabilities or for any reliance placed thereon by any person.

ADDRESS:

Wolfson Microelectronics plc
26 Westfield Road
Edinburgh
EH11 2QB
United Kingdom

Tel :: +44 (0)131 272 7000

Fax :: +44 (0)131 272 7001

Email :: sales@wolfsonmicro.com

REVISION HISTORY

DATE	REV	DESCRIPTION OF CHANGES	CHANGED BY	PAGE
16/11/10	2.2	DRC Signal Detect registers DRC_SIG_DET_RMS, DRC_SIG_DET_PK and DRC_SIG_DET_MODE updated. Additional details provided on pull-up / pull-down functions. Added notes that DRC and MBC must not be enabled simultaneously on the same playback path. Added notes that the Output Path HPF should be enabled when DRC is used on a record (ADC) path. Power domains and Ground references listed for each input/output. MICD_BIAS_STARTTIME and MICD_RATE descriptions updated, and associated text / recommended settings. Noted that DRC Anti-Clip and Quick Release features should not be used at the same time. VMID soft-start descriptions updated, including requirement to reset soft-start circuit before re-enabling VMID.	PH	
4/1/11	2.2	Speaker driver performance graphs added. SPKAB_REF_SEL added to 'Registers By Address' section. Added note that LDOs are not suitable for external loads. Noted RF suppression on analogue inputs.	PH	
24/1/11	2.2	Noise Gate function defined for AIF1 and AIF2 input paths. DAC Volume registers updated to support values up to +12dB. EQ Band 1 now configurable as Shelf or Peak filter. DSP2CLK_SRC register deleted. MBC Control sequences updated. EFS modes described for FLL1 and FLL2. Decoupling capacitor removed from DMIC connection drawing. Additional register writes added to the MBC enable sequence. Pin description list re-sorted by Name, in order to draw attention to any multiple pins with a common name. Updates noting that Ultrasonic (4FS) mode uses ADCLRCLK (not LRCLK). GPIO1/GPIO6 must be configured for AIF1/AIF2 respectively. Input Path drawing updated, showing VMID as PGA reference. Accessory detection / impedance sensing added to Introduction section and on front page.	PH	
28/1/11	2.2	Updated electrical characteristics to reflect 4 ohm mono mode THD performance.	KOL	
24/03/11	3.0	Restriction on MICBIAS capacitance clarified - 50pF limit is only applicable in Normal (regulator) mode. Applications Information (MICBIAS) enhanced to incorporate Digital Microphone connections. Interrupts section updated to improve clarity. Corrections to the FLL Example settings LDO2 output voltage updated (1.1V to 1.3V) Updated speaker inductive load conditions in electrical characteristics to 22uH. Updated LDO2 output voltage in electrical characteristics. Added max/min limits to electrical characteristics.	KOL	

DATE	REV	DESCRIPTION OF CHANGES	CHANGED BY	PAGE
14/02/11	3.0	Updated speaker inductive load in electrical characteristics to 22uH. Updated LDO2 output voltage in electrical characteristics.		
04/04/11	3.1	Notes added requiring VMID_BUF_ENA is enabled for direct signal paths from input pins to Input Mixers, Output Mixers or Speaker Mixers. Descriptions of affected register bits updated. Reel order quantity updated	PH	
18/05/11	3.3	MICBIAS modes clarified as "Regulator" mode and "Bypass" mode. Ultrasonic (4FS) mode deleted on AIF2. External Accessory Detect description & characteristics updated; Recommended External Components added in Applications Information section. Block diagram updated (input digital mixing paths and MICBIAS references) Updated ADC Path characteristics - input is -1dBV, not -1dBFS. Clarification of DAC_OSR128 modes in DAC playback path Electrical Characteristics. Input PGA Mute behaviour description updated. Noted that HPF is required when using DRC Signal Activity Detect. Updates to FLL Input Frequency range. Minimum headphone load resistance updated. Clarifications and formatting updates to Electrical Characteristics and Recommended Operating Conditions. Noted phase inversion in 'Direct Voice' paths. Clarification to the usage of the INPUTS_CLAMP register. PSRR specifications added for LDO1 and LDO2. Drop-out voltage specification added for LDO1. RMS Limiter function added within the MBC description. TSHUT_ENA default corrected in Power Management section (default is 1).	PH	
24/11/11	3.3	Absolute Maximum Ratings updated: (AVDD1 domain) added to Voltage range analogue inputs. Maximum MICBIASn load capacitance noted in Electrical Characteristics. Specifications added for LINEOUTFB and HPOUT1FB ground noise rejection.	PH	
03/01/12	3.3	System clocking updated - DBCLK is derived independently of TOCLK_ENA. Additional details in Absolute Maximum Ratings. Clarification of Line Output discharge functions and associated Electrical Characteristics.	PH	
25/05/12	3.4	Package diagram changed to DM119.A	JMacD	
1/11/12	3.5	MSL standard updated	PH	12
31/01/14	3.5	Updated control sequence for MBC Enable	PH	72

Mouser Electronics

Authorized Distributor

Click to View Pricing, Inventory, Delivery & Lifecycle Information:

[Cirrus Logic:](#)

[WM8958ECS/R](#)

Компания «Океан Электроники» предлагает заключение долгосрочных отношений при поставках импортных электронных компонентов на взаимовыгодных условиях!

Наши преимущества:

- Поставка оригинальных импортных электронных компонентов напрямую с производств Америки, Европы и Азии, а так же с крупнейших складов мира;
- Широкая линейка поставок активных и пассивных импортных электронных компонентов (более 30 млн. наименований);
- Поставка сложных, дефицитных, либо снятых с производства позиций;
- Оперативные сроки поставки под заказ (от 5 рабочих дней);
- Экспресс доставка в любую точку России;
- Помощь Конструкторского Отдела и консультации квалифицированных инженеров;
- Техническая поддержка проекта, помощь в подборе аналогов, поставка прототипов;
- Поставка электронных компонентов под контролем ВП;
- Система менеджмента качества сертифицирована по Международному стандарту ISO 9001;
- При необходимости вся продукция военного и аэрокосмического назначения проходит испытания и сертификацию в лаборатории (по согласованию с заказчиком);
- Поставка специализированных компонентов военного и аэрокосмического уровня качества (Xilinx, Altera, Analog Devices, Intersil, Interpoint, Microsemi, Actel, Aeroflex, Peregrine, VPT, Syfer, Eurofarad, Texas Instruments, MS Kennedy, Miteq, Cobham, E2V, MA-COM, Hittite, Mini-Circuits, General Dynamics и др.);

Компания «Океан Электроники» является официальным дистрибьютором и эксклюзивным представителем в России одного из крупнейших производителей разъемов военного и аэрокосмического назначения «JONHON», а так же официальным дистрибьютором и эксклюзивным представителем в России производителя высокотехнологичных и надежных решений для передачи СВЧ сигналов «FORSTAR».



JONHON

«JONHON» (основан в 1970 г.)

Разъемы специального, военного и аэрокосмического назначения:

(Применяются в военной, авиационной, аэрокосмической, морской, железнодорожной, горно- и нефтедобывающей отраслях промышленности)

«FORSTAR» (основан в 1998 г.)

ВЧ соединители, коаксиальные кабели, кабельные сборки и микроволновые компоненты:

(Применяются в телекоммуникациях гражданского и специального назначения, в средствах связи, РЛС, а так же военной, авиационной и аэрокосмической отраслях промышленности).



Телефон: 8 (812) 309-75-97 (многоканальный)

Факс: 8 (812) 320-03-32

Электронная почта: ocean@oceanchips.ru

Web: <http://oceanchips.ru/>

Адрес: 198099, г. Санкт-Петербург, ул. Калинина, д. 2, корп. 4, лит. А