

General Description

The MAX14871 evaluation kit (EV kit) consists of a MAX14871 evaluation board. The EV kit is a fully assembled and tested circuit board that evaluates the MAX14871 full-bridge DC motor driver

The EV kit is designed to work as either a stand-alone board or with a software interface, demonstrating all of the major features of the device.

Features

- Operates From a Wide 4.5V to 36V Supply
- Standalone or Software-Controlled Operation
- Proven PCB Layout
- Fully Assembled and Tested

Ordering Information appears at end of data sheet.

MAX14871 EV Kit Block Diagram

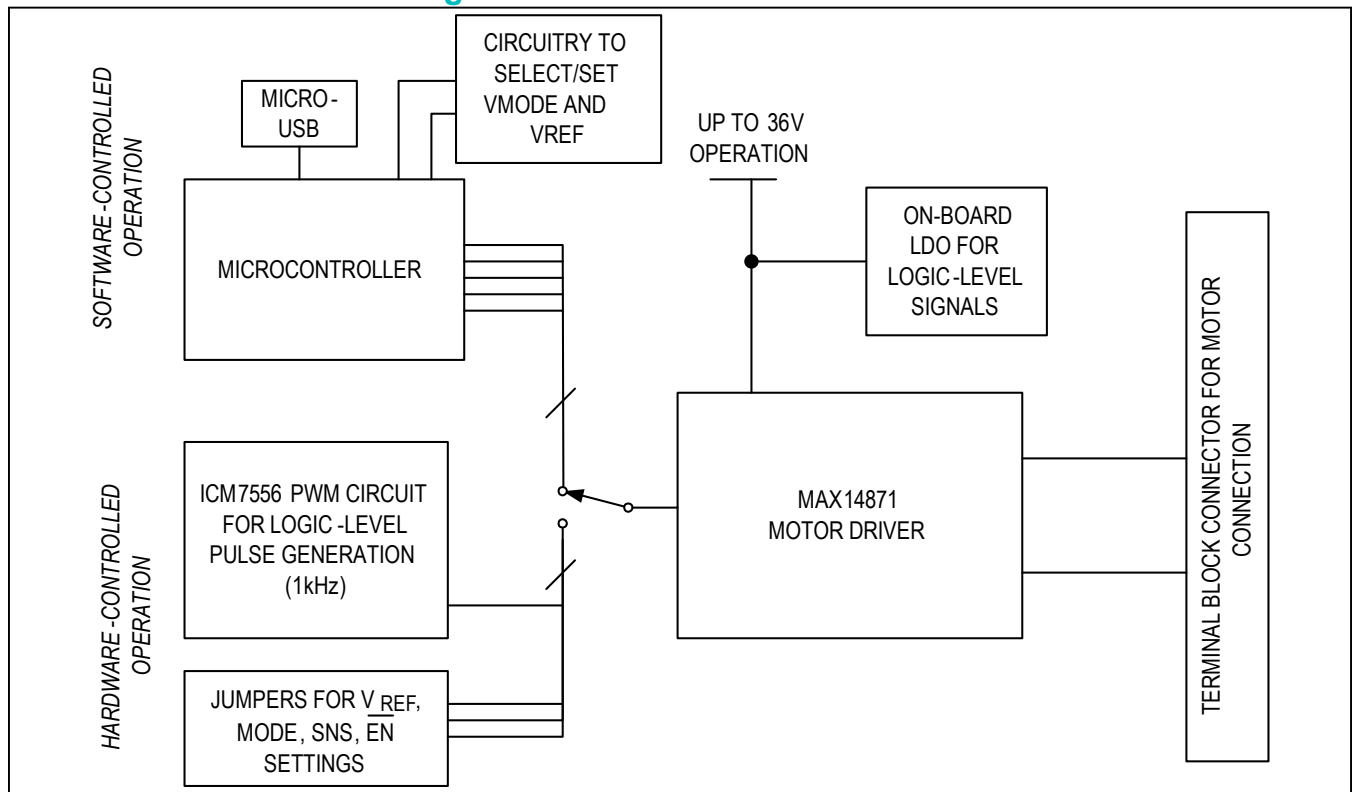

Quick Start

Recommended Equipment

- MAX14871 EV kit
- User-supplied Windows XP®, Windows Vista®, or Windows 7 PC with a spare USB port.
- 24V, 1A power supply
- DC brushed motor

Procedure

The EV kit is fully assembled and tested. Follow the steps below to verify board operation before exercising the full features of the device:

- 1) Verify that all jumpers are in their default positions, as shown in [Table 1](#).
- 2) Connect the 24V DC power supply on the VCC and GND connectors on the EV kit board.
- 3) See application note Using the MAX14871EVKIT with software to configure the board for software operation.
- 4) Connect the DC brushed motor to the M1 and M2 terminals in the J12 connector.
- 5) Turn on the 24V power supply.

Detailed Description of Hardware

The MAX14871 EV kit is a fully tested circuit board demonstrating the capabilities of the MAX14871 motor driver.

Stand-Alone Operation

Remove all of the shunts on the P2 header for stand-alone operation. On-board LDOs generate logic rails and headers are included for device configuration in stand-alone mode.

On-Board LDO

The MAX15006 (U5) on-board LDO generates 3.3V for logic signals and for powering the fault LED. The 3.3V LDO also powers the on-board ICM7556 PWM signal generator.

On-Board PWM Generator

The ICM7556 (U2) general-purpose timer circuit is available to generate PWM signals for switching either the PWM or DIR inputs. Adjust the R1 potentiometer to change the duty cycle of the output signal.

The EV kit comes with the PWM frequency set up to 1kHz but can be adjusted up to 10kHz by changing the C3 capacitor. Set the PWM frequency using the following equation:

$$f_{SW} = 1.46 / [(R_{29} + 2 \times R_{32}) \times C_3]$$

Motor Operation

The MAX14871 is capable of operating in any one of three current regulation modes: fast decay, slow decay, or 25% ripple current mode. To set the mode, apply a voltage to VMODE and VREF ([Table 2](#)).

VREF

Set the VREF voltage to limit the motor current using the following equation:

$$V_{REF} = I_{MOTOR} \times A_V \times R_{SENSE}$$

For easy evaluation, J6 can be used to set the VREF voltage to 3.3V or 0V. Connect 1-2 on J6 to set VREF to 3.3V. Connect 2-3 on J6 to set VREF to 0V.

MODE

The J7 jumper can be used to set the MODE voltage high (3.3V) or low (0V). For 25% ripple mode, however, the MODE voltage must be between 0.5V and 1V. Apply an external voltage to the MODE test point, or connect a resistor divider on the R3 and R5 resistor pads to set the MODE voltage for this mode of operation.

Fault Indicator LED

The FAULT output is connected to the 3.3V logic supply through R4. LED1 turns on during a fault condition.

Table 1. Jumper Descriptions

JUMPER	SHUNT POSITON	DESCRIPTION
J1	1-2	PWM is high.
	2-3	PWM is low.
J2	1-2	DIR is high.
	2-3	DIR is low.
J3	1-2*	SNS is connected to COM.
	2-3	SNS is connected to GND.
J4	1-2	Output of the on-board pulse generator circuit is connected to PWM.
	2-3	Output of the on-board pulse generator circuit is connected to DIR.
J5	1-2	$\overline{\text{EN}}$ is high.
	2-3	$\overline{\text{EN}}$ is low.
J6	1-2	VREF is connected to 3.3V.
	2-3	VREF is connected to 0V.
J7	1-2	MODE is connected to 3.3V.
	2-3	MODE is connected to 0V.
	Open*	V _{MODE} is set by the software or by the R3 and R5 voltage divider. R3 and R5 are DNI.
J8	Open*	COM is not shorted to ground.
	Closed	COM is shorted to ground.
J9	Open*	This jumper is used to program the on-board microcontroller. Do not shunt this jumper.
	Closed	
J10	Open*	This jumper is used to program the on-board microcontroller. Do not shunt this jumper.
	Closed	
J11	Open*	This jumper is used to program the on-board microcontroller. Do not shunt this jumper.
	Closed	
J13	1-2*	VREF is set by the on-board microcontroller circuitry.
	3-4*	MODE is set by the on-board microcontroller circuitry.
	5-6*	FAULT is connected to the microcontroller.
	7-8*	PWM signal is generated by the on-board microcontroller.
	9-10*	DIR signal is generated by the on-board microcontroller.
	11-12*	$\overline{\text{EN}}$ signal is generated by the on-board microcontroller.

*Default position.

Table 2. Current Regulation Logic

INPUTS				OPERATING MODE
$\overline{\text{EN}}$	V_{REF}	MODE	V_{SNS}	
0	< 0.2V	X	< 0.1V	Normal PWM Operation. No current regulation.
0	< 0.2V	$V_{\text{MODE}} < 0.5\text{V}$	> 0.1V	Current regulation based on 15 μs (typ) fixed off-time control with fast decay using internal V_{REF} .
0	< 0.2V	$0.5\text{V} < V_{\text{MODE}} < 1\text{V}$	> 0.1V	Current regulation based on 25% current ripple fast decay using internal V_{REF} .
0	< 0.2V	$V_{\text{MODE}} > 1.5\text{V}$	> 0.1V	Current regulation based on 15 μs (typ) fixed off-time control with slow decay using internal V_{REF} .
0	> 0.4V	X	< $V_{\text{VREF}}/10$	Normal PWM Operation. No current regulation.
0	> 0.4V	$V_{\text{MODE}} < 0.5\text{V}$	> $V_{\text{VREF}}/10$	Current regulation based on fixed TOFF-time control with fast decay using external V_{REF} .
0	> 0.4V	$0.5\text{V} < V_{\text{MODE}} < 1\text{V}$	> $V_{\text{VREF}}/10$	Current regulation based on 25% current ripple fast decay using external V_{REF} .
0	> 0.4V	$V_{\text{MODE}} > 1.5\text{V}$	> $V_{\text{VREF}}/10$	Current regulation based on fixed TOFF-time control with slow decay using external V_{REF} .

X = Don't care

Ordering Information

PART	TYPE
MAX14871EVKIT#	EV Kit

#Denotes RoHS compliant.

Component Information

See the following links for component information, PCB files, and schematics:

- [MAX14871 EV BOM](#)
- [MAX14871 EV Schematic](#)
- [MAX14871 EV PCB](#)

Revision History

REVISION NUMBER	REVISION DATE	DESCRIPTION	PAGES CHANGED
0	6/15	Initial release	—

For pricing, delivery, and ordering information, please contact Maxim Direct at 1-888-629-4642, or visit Maxim Integrated's website at www.maximintegrated.com.

Maxim Integrated cannot assume responsibility for use of any circuitry other than circuitry entirely embodied in a Maxim Integrated product. No circuit patent licenses are implied. Maxim Integrated reserves the right to change the circuitry and specifications without notice at any time.



This document contains information considered proprietary, and shall not be reproduced wholly or in part, nor disclosed to others without specific written permission.

HARDWARE NAME: MAX14871_EVKIT_A

HARDWARE NUMBER: EPCB14871

ENGINEER:

DESIGNER:

DATE: 12/16/2014

ODB++/GERBER: SILK_TOP

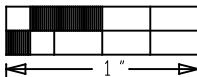
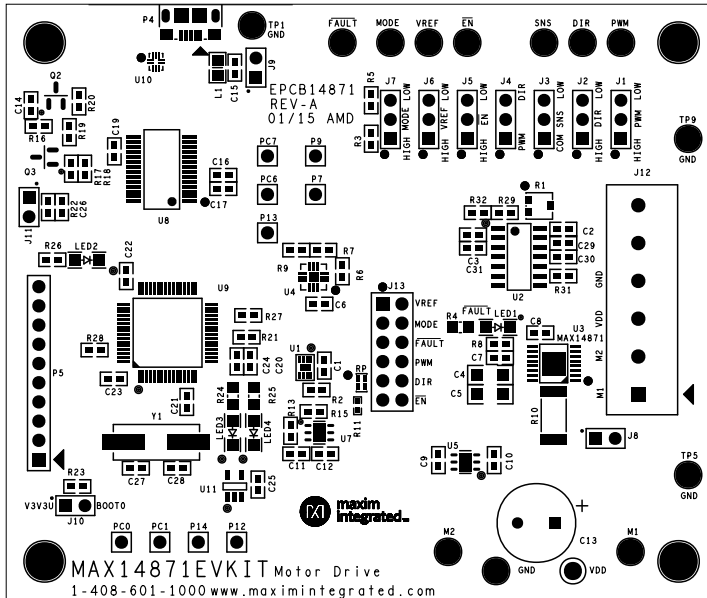



This document contains information considered proprietary, and shall not be reproduced wholly or in part, nor disclosed to others without specific written permission.

HARDWARE NAME: MAX14871_EVKIT_A

HARDWARE NUMBER: EPCB14871

ENGINEER:

DESIGNER:

DATE: 12/16/2014

ODB++/GERBER: LAYER 2

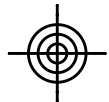
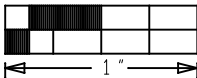
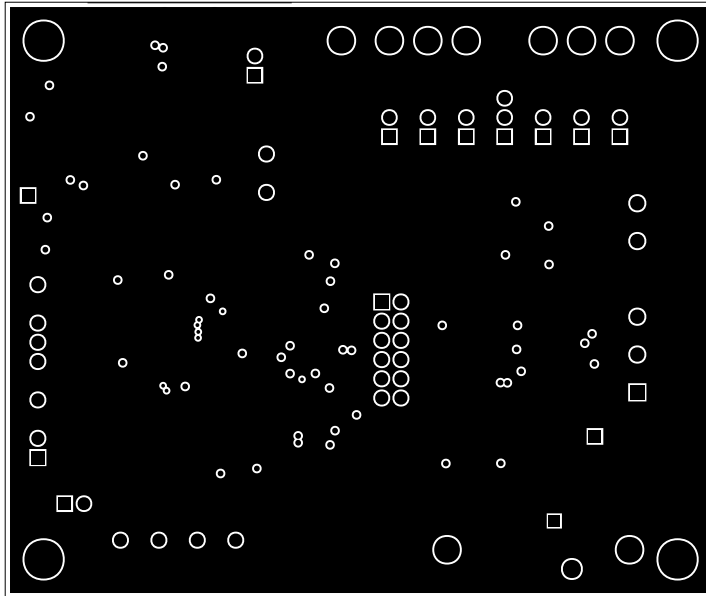



This document contains information considered proprietary, and shall not be reproduced wholly or in part, nor disclosed to others without specific written permission.

HARDWARE NAME: MAX14871_EVKIT_A

HARDWARE NUMBER: EPCB14871

ENGINEER:

DESIGNER:

DATE: 12/16/2014

ODB++/GERBER: LAYER 3

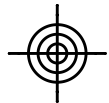
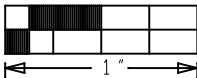
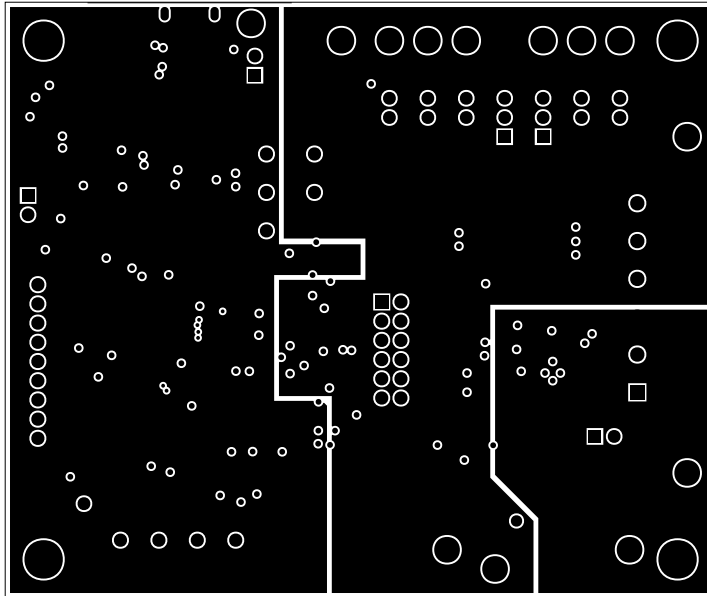



This document contains information considered proprietary, and shall not be reproduced wholly or in part, nor disclosed to others without specific written permission.

HARDWARE NAME: MAX14871_EVKIT_A

HARDWARE NUMBER: EPCB14871

ENGINEER:

DESIGNER:

DATE: 12/16/2014

ODB++/GERBER: TOP

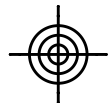
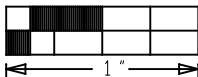
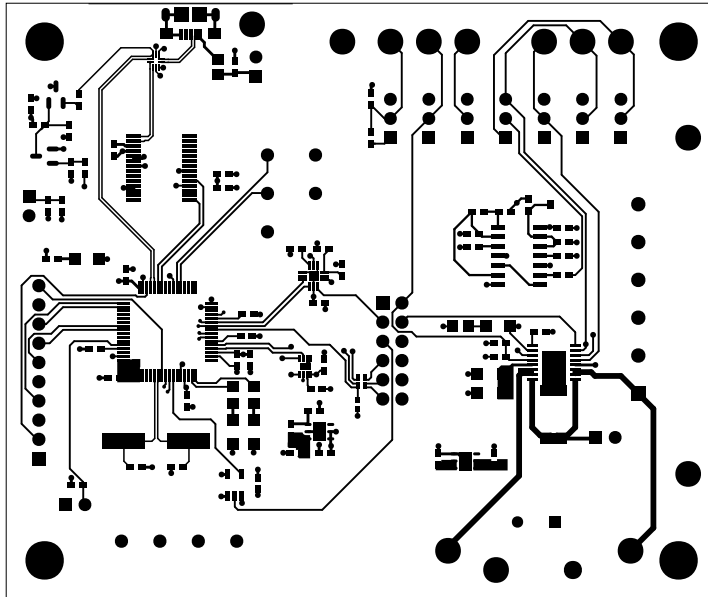



This document contains information considered proprietary, and shall not be reproduced wholly or in part, nor disclosed to others without specific written permission.

HARDWARE NAME: MAX14871_EVKIT_A

HARDWARE NUMBER: EPCB14871

ENGINEER:

DESIGNER:

DATE: 12/16/2014

ODB++/GERBER: BOTTOM

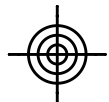
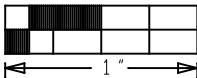
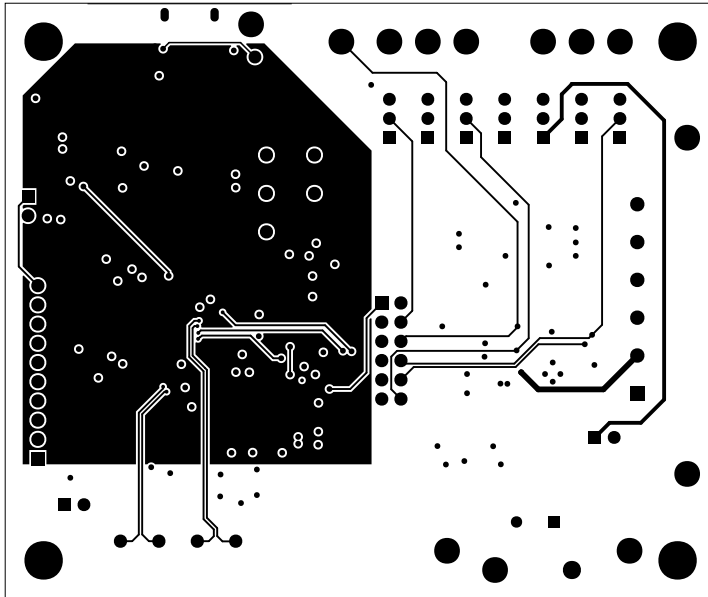

Bill of Materials

DATE: 01/08/2015

DESIGN: max14871_evkit_a

Revision_Type : PRODUCTION

ITEM	QTY	REF DES	MFG PART #	MANUFACTURER	VALUE	DESCRIPTION
1	8	C1,C2,C6,C7,C19,C25,C26,C29			0.1UF	CAPACITOR; SMT (0603); CERAMIC CHIP; 0.1UF; 16V; TOL=10%; MODEL=; TG=-55 DEGC TO +125 DEGC; TC=X7R; NOT RECOMMENDED FOR NEW DESIGN USE 20-000u1-01
2	3	C3,C30,C31			0.01UF	CAPACITOR; SMT (0603); CERAMIC CHIP; 0.01UF; 50V; TOL=5%; MODEL=X7R; TG=-55 DEGC TO +125 DEGC; TC=+/-
3	2	C4,C5			1UF	CAPACITOR; SMT (1206); CERAMIC CHIP; 1UF; 50V; TOL=10%; TG=-55 DEGC TO +125 DEGC; TC=X7R
4	1	C8			220PF	CAPACITOR; SMT (0603); CERAMIC CHIP; 220PF; 50V; TOL=5%; MODEL=PPS; TG=-55 DEGC TO +85 DEGC; TC=+/-
5	1	C9			2.2UF	CAPACITOR; SMT (0603); CERAMIC CHIP; 2.2UF; 25V; TOL=10%; MODEL=; TG=-55 DEGC TO +85 DEGC; TC=X5R
6	1	C10			0.1UF	CAPACITOR; SMT (0603); CERAMIC CHIP; 0.1UF; 50V; TOL=10%; MODEL=C SERIES; TG=-55 DEGC TO +85 DEGC; TC=X5R
7	4	C11,C15,C17,C23			4.7UF	CAPACITOR; SMT; 0603; CERAMIC; 4.7uF; 10V; 10%; X5R; 55degC to + 85degC; 0 +/-15% degC MAX.
8	7	C12,C14,C16,C20-C22,C24			1UF	CAPACITOR; SMT (0603); CERAMIC CHIP; 1UF; 25V; TOL=10%; MODEL=GRM SERIES; TG=-55 DEGC TO +125 DEGC; TC=X7R
9	1	C13			330UF	CAPACITOR; THROUGH HOLE-RADIAL LEAD; ALUMINUM-ELECTROLYTIC; 330UF; 50V; TOL=20%; MODEL=EB SERIES; TG=-40 DEGC TO +105 DEGC
10	2	C27,C28			18PF	CAPACITOR; SMT (0603); CERAMIC CHIP; 18PF; 50V; TOL=5%; MODEL=; TG=-55 DEGC TO +125 DEGC; TC=C0G
11	9	EN,M1,M2,DIR,PWM,SNS,MODE,VREF,FAULT	5014	KEYSTONE	N/A	TEST POINT; PIN DIA=0.125IN; TOTAL LENGTH=0.445IN; BOARD HOLE=0.063IN; YELLOW; PHOSPHOR BRONZE WIRE SILVER PLATE FINISH; RECOMMENDED FOR BOARD THICKNESS=0.062IN; NOT FOR COLD TEST
12	4	GND,TP1,TP5,TP9	5011	KEYSTONE	N/A	TEST POINT; PIN DIA=0.125IN; TOTAL LENGTH=0.445IN; BOARD HOLE=0.063IN; BLACK; PHOSPHOR BRONZE WIRE SILVER PLATE FINISH; RECOMMENDED FOR BOARD THICKNESS=0.062IN; NOT FOR COLD TEST
13	7	J1-J7	PCC03SAAN	SULLINS	PCC03SAAN	CONNECTOR; MALE; THROUGH HOLE; BREAKAWAY; STRAIGHT THROUGH; 3PINS; -65 DEGC TO +125 DEGC
14	1	J8	PCC02SAAN	SULLINS	PCC02SAAN	CONNECTOR; MALE; THROUGH HOLE; BREAKAWAY; STRAIGHT THROUGH; 2PINS; -65 DEGC TO +125 DEGC
15	3	J9-J11	PEC02SAAN	SULLINS	PEC02SAAN	CONNECTOR; MALE; THROUGH HOLE; BREAKAWAY; STRAIGHT; 2PINS; -65 DEGC TO +125 DEGC
16	1	J12	1935200	PHOENIX CONTACT SULLINS	1935200	CONNECTOR; FEMALE; THROUGH HOLE; GREEN TERMINAL BLOCK; STRAIGHT; 6PINS
17	1	J13	PEC06DAAN	ELECTRONICS CORP.	PEC06DAAN	CONNECTOR; MALE; THROUGH HOLE; BREAKAWAY; STRAIGHT; 12PINS; -65 DEGC TO +125 DEGC
18	1	L1	BLM21AG601SN1D	MURATA	600	INDUCTOR; SMT (0805); FERRITE-BEAD; 600; TOL=+/-25%; 0.2A

19	3	LED1-LED3	597-3111-407F	DIALIGHT	597-3111-407F	DIODE; LED; SMT LED; RED; SMT (1206); PIV=4V; IF=0.03A
20	1	LED4	597-3311-407F	DIALIGHT	597-3311-407F	DIODE; LED; STANDARD; GREEN; SMT (1206); PIV=2.1V; IF=0.02A
21	1	P4	10118193-0001LF	FCI CONNECT	10118193-0001LF	CONNECTOR; FEMALE; SMT; MICRO USB B TYPE RECEPTACLE; RIGHT ANGLE; 5PINS
22	2	Q2,Q3	MMBT3904	N/A	MMBT3904	TRANSISTOR, NPN, SOT-23, PD=0.225W, IC=0.2A, VCEO=40V
23	1	R1	PVZ3A103C01	?	10K	RESISTOR; SMT J-LEAD; TRIMMER POTENTIOMETER; 1 TURN; 10K OHM; 30%; 500PPM; 0.1W; TADJ; CARBON FILM
24	8	R2,R7,R13,R21-R23,R27,R28			10K	RESISTOR; 0603; 10K OHM; 1%; 100PPM; 0.0125W; THICK FILM
25	1	R4			270	RESISTOR; 0805; 270 OHM; 1%; 100PPM; 0.125W; THICK FILM
26	1	R6			34K	RESISTOR; 0603; 34K OHM; 1%; 100PPM; 0.10W; THICK FILM
27	2	R9,R26			1K	RESISTOR; 0603; 1K OHM; 1%; 100PPM; 0.10W; THICK FILM
28	1	R10			0.1	RESISTOR; 2512; 0.1 OHM; 1%; 75PPM; 3W; METAL FILM
29	1	R11			10K	RESISTOR; 0402; 10K; 1%; 100PPM; 0.0625W; THICK FILM
30	1	R15			6.04K	RESISTOR; 0603; 6.04K; 1%; 100PPM; 0.10W; THICK FILM
31	1	R16			3.92K	RESISTOR; 0603; 3.92K OHM; 0.1%; 25PPM; 0.10W; THICK FILM
32	1	R17			39.2K	RESISTOR; 0603; 39.2K; 1%; 100PPM; 0.10W; THICK FILM
33	1	R18			332	RESISTOR; 0603; 332 OHM; 1%; 100PPM; 0.10W; THICK FILM
34	1	R19			102K	RESISTOR; 0603; 102K OHM; 1%; 100PPM; 0.10W; THICK FILM
35	1	R20			1.5K	RESISTOR; 0603; 1.5K; 1%; 100PPM; 0.10W; THICK FILM
36	2	R24,R25			137	RESISTOR; 0805; 137 OHM; 1%; 100PPM; 0.125W; THICK FILM
37	1	R29			120K	RESISTOR; 0603; 120K OHM; 1%; 100PPM; 0.10W; THICK FILM
38	1	R31			0	RESISTOR; 0603; 0 OHM; 5%; JUMPER; 0.10W; THICK FILM
39	1	R32			13K	RESISTOR; 0603; 13K OHMS; 1%; 100PPM; 0.1W; THICK FILM
40	1	RP			1K	RESISTOR; ARRAY; 0402; 1K OHM; 5%; 200PPM; 0.063W; THICK FILM
41	10	SU1-SU10	STC02SYAN	SULLINS ELECTRONICS CORP.	STC02SYAN	TEST POINT; JUMPER; STR; TOTAL LENGTH=0.256IN; BLACK; INSULATION=PBT CONTACT=PHOSPHOR BRONZE; COPPER PLATED TIN OVERALL
42	1	U1	MAX5394LATA+	MAXIM	MAX5394LATA+	IC; DPOT; SINGLE; 256-TAP VOLATILE; SPI; LOW-VOLTAGE TAPER DIGITAL POTENTIOMETER; TDFN8-EP 2MMX2MM
43	1	U2	ICM7556ISD+	MAXIM	ICM7556ISD+	IC; TIMR; GENERAL PURPOSE TIMER; NSOIC14 150MIL
44	1	U3	MAX14871EUE+	MAXIM	MAX14871EUE+	IC; DRV; 12V FULL BRIDGE DC MOTOR DRIVER; TSSOP16-EP
45	1	U4	MAX4704EGC+	MAXIM	MAX4704EGC+	IC; AMUX; LOW-VOLTAGE; 600HMS; 4:1 ANALOG MULTIPLEXER IN QFN; QFN12-EP 3X3
46	1	U5	MAX15006AATT+	MAXIM	MAX15006AATT+	IC; VREG; ULTRA-LOW QUIESCENT-CURRENT LINEAR REGULATOR; TDFN6-EP 3X3
47	1	U7	MAX8880ETT+	MAXIM	MAX8880ETT+	IC; VREG; 12V; ULTRA-LOW-IQ; LOW-DROPOUT LINEAR REGULATOR WITH POK; TDFN6-EP 3X3
48	1	U8	FT232RL	FUTURE TECHNOLOGY DEVICES INTL LTD.	FT232RL	IC; INFC; USB UART INTERFACE; SSOP28

49	1	U9	STM32F103RET6	ST MICROELECTR ONICS	STM32F103RET6	IC; MMR; HIGH-DENSITY PERFORMANCE LINE ARM-BASED 32-BIT MCU WITH 512KB FLASH; 11 TIMERS; 3 ADC; 13 COMMUNICATION INTERFACE; LQFP64 10X10
50	1	U10	MAX14585AEVB +	MAXIM	MAX14585AEVB+	IC; ASW; HI-SPEED USB AND AUDIO SWITCHES WITH NEGATIVE SIGNAL CAPABILITY AND HIGH-VOLATGE-TOLERABLE VBUS DETECTION; UTQFN10 1.4X1.8
51	1	U11	NC7SZ125M5X	FAIRCHILD SEMICONDUCT OR	NC7SZ125M5X	IIC; BUF; TINYLOGIC UHS BUFFER WITH THREE-STATE OUTPUT; SOT23-5
52	1	VDD	5010	?	N/A	TESTPOINT WITH 1.80MM HOLE DIA, RED, MULTIPURPOSE; NOT FOR COLD TEST
53	1	Y1	HCM49- 8.000MABJ-UT	CITIZEN	8MHZ	CRYSTAL; SMT ; AT-CUT CRYSTAL UNIT; 18PF; 8MHZ; +/-30PPM; +/-30PPM
54	1		EPCB14871	MAXIM	PCB	PCB: EPCB14871
TOTAL	114					
NOT INSERT(DNI)						
ITEM	QTY	REF DES	MFG PART #	MANUFACTUR ER	VALUE	DESCRIPTION
1	1	P5	PEC10SAAN	SULLINS ELECTRONICS CORP.	PEC10SAAN	CONNECTOR; MALE; THROUGH HOLE; BREAKAWAY; STRAIGHT; 10PINS
2	9	P7,P9,P12-P14,PC0,PC1,PC6,PC7	PEC01SAAN	SULLINS ELECTRONICS CORP	PEC01SAAN	CONNECTOR; MALE; THROUGH HOLE; BREAKAWAY; STRAIGHT; 1PIN
3	3	R3,R5,R8	N/A	N/A	OPEN	PACKAGE OUTLINE 0603 RESISTOR - EVKIT
TOTAL	13					

Компания «Океан Электроники» предлагает заключение долгосрочных отношений при поставках импортных электронных компонентов на взаимовыгодных условиях!

Наши преимущества:

- Поставка оригинальных импортных электронных компонентов напрямую с производств Америки, Европы и Азии, а так же с крупнейших складов мира;
- Широкая линейка поставок активных и пассивных импортных электронных компонентов (более 30 млн. наименований);
- Поставка сложных, дефицитных, либо снятых с производства позиций;
- Оперативные сроки поставки под заказ (от 5 рабочих дней);
- Экспресс доставка в любую точку России;
- Помощь Конструкторского Отдела и консультации квалифицированных инженеров;
- Техническая поддержка проекта, помощь в подборе аналогов, поставка прототипов;
- Поставка электронных компонентов под контролем ВП;
- Система менеджмента качества сертифицирована по Международному стандарту ISO 9001;
- При необходимости вся продукция военного и аэрокосмического назначения проходит испытания и сертификацию в лаборатории (по согласованию с заказчиком);
- Поставка специализированных компонентов военного и аэрокосмического уровня качества (Xilinx, Altera, Analog Devices, Intersil, Interpoint, Microsemi, Actel, Aeroflex, Peregrine, VPT, Syfer, Eurofarad, Texas Instruments, MS Kennedy, Miteq, Cobham, E2V, MA-COM, Hittite, Mini-Circuits, General Dynamics и др.);

Компания «Океан Электроники» является официальным дистрибьютором и эксклюзивным представителем в России одного из крупнейших производителей разъемов военного и аэрокосмического назначения «JONHON», а так же официальным дистрибьютором и эксклюзивным представителем в России производителя высокотехнологичных и надежных решений для передачи СВЧ сигналов «FORSTAR».



JONHON

«JONHON» (основан в 1970 г.)

Разъемы специального, военного и аэрокосмического назначения:

(Применяются в военной, авиационной, аэрокосмической, морской, железнодорожной, горно- и нефтедобывающей отраслях промышленности)

«FORSTAR» (основан в 1998 г.)

ВЧ соединители, коаксиальные кабели, кабельные сборки и микроволновые компоненты:

(Применяются в телекоммуникациях гражданского и специального назначения, в средствах связи, РЛС, а так же военной, авиационной и аэрокосмической отраслях промышленности).



Телефон: 8 (812) 309-75-97 (многоканальный)

Факс: 8 (812) 320-03-32

Электронная почта: ocean@oceanchips.ru

Web: <http://oceanchips.ru/>

Адрес: 198099, г. Санкт-Петербург, ул. Калинина, д. 2, корп. 4, лит. А