

VOLTAGE-CONTROLLED CRYSTAL OSCILLATOR (VCXO) 100 kHz TO 250 MHz

Features

- Supports any frequency from 100 kHz to 250 MHz
- Low-jitter operation
- Short lead times: <2 weeks
- AT-cut fundamental mode crystal ensures high reliability/low aging
- High power supply noise rejection
- 1% control voltage linearity
- Available CMOS, LVPECL, LVDS, and HCSL outputs
- Optional integrated 1:2 CMOS fanout buffer
- 3.3 and 2.5 V supply options
- Industry-standard 5x7, 3.2x5, and 2.5x3.2 mm packages
- Pb-free/RoHS-compliant
- Selectable Kv (60, 90, 120, 150 ppm/V)

Applications

- SONET/SDH/OTN
- PON
- Low Jitter PLLs
- xDSL
- Broadcast video
- Telecom
- Switches/routers
- FPGA/ASIC clock generation

Description

The Si515 VCXO utilizes Silicon Laboratories' advanced PLL technology to provide any frequency from 100 kHz to 250 MHz. Unlike a traditional VCXO where a different crystal is required for each output frequency, the Si515 uses one fixed crystal and Silicon Labs' proprietary synthesizer to generate any frequency across this range. This IC-based approach allows the crystal resonator to provide enhanced reliability, improved mechanical robustness, and excellent stability. In addition, this solution provides superior control voltage linearity and supply noise rejection, improving PLL stability and simplifying low jitter PLL design in noisy environments. The Si515 is factory-configurable for a wide variety of user specifications, including frequency, supply voltage, output format, tuning slope and stability. Specific configurations are factory-programmed at time of shipment, eliminating long lead times and non-recurring engineering charges associated with custom frequency oscillators.

Functional Block Diagram



TABLE OF CONTENTS

<u>Section</u>	<u>Page</u>
1. Electrical Specifications	3
2. Solder Reflow and Rework Requirements for 2.5x3.2 mm Packages	11
3. Pin Descriptions	12
3.1. Dual CMOS Buffer	13
4. Ordering Information	14
5. Package Outline Diagram: 5 x 7 mm, 6-pin	15
6. PCB Land Pattern: 5 x 7 mm, 6-pin	16
7. Package Outline Diagram: 3.2 x 5.0 mm, 6-pin	17
8. PCB Land Pattern: 3.2 x 5.0 mm, 6-pin	18
9. Package Outline Diagram: 2.5 x 3.2 mm, 6-pin	19
10. PCB Land Pattern: 2.5 x 3.2 mm, 6-pin	21
11. Top Marking	22
11.1. Si515 Top Marking	22
11.2. Top Marking Explanation	22
Document Change List	23

1. Electrical Specifications

Table 1. Recommended Operating Conditions

$V_{DD} = 2.5$ or 3.3 V $\pm 10\%$, $T_A = -40$ to $+85$ °C

Parameter	Symbol	Test Condition	Min	Typ	Max	Unit
Supply Voltage	V_{DD}	3.3 V option	2.97	3.3	3.63	V
		2.5 V option	2.25	2.5	2.75	V
Supply Current	I_{DD}	CMOS, 100 MHz, single-ended	—	24	29	mA
		LVDS (output enabled)	—	22	26	mA
		LVPECL (output enabled)	—	42	46	mA
		HCSL (output enabled)	—	44	47	mA
		Tristate (output disabled)	—	—	22	mA
OE “1” Setting	V_{IH}	See Note	$0.80 \times V_{DD}$	—	—	V
OE “0” Setting	V_{IL}	See Note	—	—	$0.20 \times V_{DD}$	V
OE Internal Pull-Up/ Pull-Down Resistor*	R_I		—	45	—	k Ω
Operating Temperature	T_A		-40	—	85	°C

***Note:** Active high and active low polarity OE options available. Active high uses internal pull-up. Active low uses internal pull-down. See ordering information on page 13.

Table 2. Vc Control Voltage Input

$V_{DD} = 2.5$ or 3.3 V $\pm 10\%$, $T_A = -40$ to $+85$ °C

Parameter	Symbol	Test Condition	Min	Typ	Max	Unit
Control Voltage Range	V_C		$0.1 \times V_{DD}$	$V_{DD}/2$	$0.9 \times V_{DD}$	V
Control Voltage Tuning Slope (10 to 90% V_{DD})	Kv	Positive slope, ordering option	60, 90, 120, 150			ppm/V
Kv Variation	Kv_var		—	—	± 10	%
Control Voltage Linearity	L_{VC}	BSL	-5	± 1	+5	%
Modulation Bandwidth	BW		—	10	—	kHz
Vc Input Impedance	Z_{VC}		—	100	—	k Ω

Table 3. Output Clock Frequency Characteristics

$V_{DD} = 2.5$ or 3.3 V $\pm 10\%$, $T_A = -40$ to $+85$ °C

Parameter	Symbol	Test Condition	Min	Typ	Max	Unit
Nominal Frequency	F_O	CMOS, Dual CMOS	0.1	—	212.5	MHz
	F_O	LVDS/LVPECL/HCSL	0.1	—	250	MHz
Temperature Stability	S_T	$T_A = -40$ to $+85$ °C	-20	—	+20	ppm
Aging	A	Frequency drift over 10 year life	—	—	± 8.5	ppm
Minimum Absolute Pull Range	APR	Ordering option	$\pm 30, \pm 50, \pm 80, \pm 100$			ppm
Startup Time	T_{SU}	Minimum V_{DD} to output frequency (F_O) within specification	—	—	10	ms
Disable Time	T_D	$F_O \geq 10$ MHz	—	—	5	μ s
		$F_O < 10$ MHz			40	μ s
Enable Time	T_E	$F_O \geq 10$ MHz	—	—	20	μ s
		$F_O < 10$ MHz			60	μ s

Table 4. Output Clock Levels and Symmetry $V_{DD} = 2.5$ or 3.3 V $\pm 10\%$, $T_A = -40$ to $+85$ °C

Parameter	Symbol	Test Condition	Min	Typ	Max	Unit
CMOS Output Logic High	V_{OH}		$0.85 \times V_{DD}$	—	—	V
CMOS Output Logic Low	V_{OL}		—	—	$0.15 \times V_{DD}$	V
CMOS Output Logic High Drive	I_{OH}	3.3 V	-8	—	—	mA
		2.5 V	-6	—	—	mA
CMOS Output Logic Low Drive	I_{OL}	3.3 V	8	—	—	mA
		2.5 V	6	—	—	mA
CMOS Output Rise/Fall Time (20 to 80% V_{DD})	T_R/T_F	0.1 to 125 MHz, $C_L = 15$ pF	—	0.8	1.2	ns
		0.1 to 212.5 MHz, $C_L =$ no load	—	0.6	0.9	ns
LVPECL/HCSL Output Rise/Fall Time (20 to 80% V_{DD})	T_R/T_F		—	—	565	ps
LVDS Output Rise/Fall Time (20 to 80% V_{DD})	T_R/T_F		—	—	800	ps
LVPECL Output Common Mode	V_{OC}	50Ω to $V_{DD} - 2$ V, single-ended	—	$V_{DD} - 1.4$ V	—	V
LVPECL Output Swing	V_O	50Ω to $V_{DD} - 2$ V, single-ended	0.55	0.8	0.90	V_{PPSE}
LVDS Output Common Mode	V_{OC}	100Ω line-line, $V_{DD} = 3.3/2.5$ V	1.13	1.23	1.33	V
LVDS Output Swing	V_O	Single-ended 100Ω differential termination	0.25	0.38	0.42	V_{PPSE}
HCSL Output Common Mode	V_{OC}	50Ω to ground	0.35	0.38	0.42	V
HCSL Output Swing	V_O	Single-ended	0.58	0.73	0.85	V_{PPSE}
Duty Cycle	DC		48	50	52	%

Table 5. Output Clock Jitter and Phase Noise (LVPECL)

$V_{DD} = 2.5$ or 3.3 V $\pm 10\%$, $T_A = -40$ to $+85$ °C; Output Format = LVPECL

Parameter	Symbol	Test Condition	Min	Typ	Max	Unit
Period Jitter (RMS)	J_{PRMS}	10 k samples ¹	—	—	1.3	ps
Period Jitter (PK-PK)	J_{PPKPK}	10 k samples ¹	—	—	11	ps
Phase Jitter (RMS)	ϕ_J	12 kHz to 20 MHz ² (brickwall)	—	0.9	1.3	ps
		1.875 MHz to 20 MHz ² (brickwall)	—	0.25	0.5	ps
Phase Noise, 155.52 MHz	ϕ_N	100 Hz offset	—	-71	—	dBc/Hz
		1 kHz offset	—	-93	—	dBc/Hz
		10 kHz offset	—	-113	—	dBc/Hz
		100 kHz offset	—	-124	—	dBc/Hz
		1 MHz offset	—	-136	—	dBc/Hz
Additive RMS Jitter Due to External Power Supply Noise ³	J_{PSRR}	100 kHz sinusoidal noise	—	4.0	—	ps
		200 kHz sinusoidal noise	—	3.5	—	ps
		500 kHz sinusoidal noise	—	3.5	—	ps
		1 MHz sinusoidal noise	—	3.5	—	ps
Spurious Performance	SPR	$F_O = 156.25$ MHz, Offset > 10 kHz	—	-75	—	dBc

Notes:

1. Applies to output frequencies: 74.17582, 74.25, 75, 77.76, 100, 106.25, 125, 148.35165, 148.5, 150, 155.52, 156.25, 212.5, 250 MHz.
2. Applies to output frequencies: 100, 106.25, 125, 148.35165, 148.5, 150, 155.52, 156.25, 212.5, 250 MHz.
3. 156.25 MHz. Increase in jitter on output clock due to spurs introduced by sinewave noise added to VDD (100 mV_{pp}).

Table 6. Output Clock Jitter and Phase Noise (LVDS)

$V_{DD} = 1.8\text{ V} \pm 5\%$, 2.5 or 3.3 V $\pm 10\%$, $T_A = -40$ to $+85\text{ }^\circ\text{C}$; Output Format = LVDS

Parameter	Symbol	Test Condition	Min	Typ	Max	Unit
Period Jitter (RMS)	JPRMS	10k samples ¹	—	—	2.1	ps
Period Jitter (Pk-Pk)	JPPKPK	10k samples ¹	—	—	18	ps
Phase Jitter (RMS)	ϕJ	1.875 MHz to 20 MHz integration bandwidth ² (brickwall)	—	0.25	0.55	ps
		12 kHz to 20 MHz integration bandwidth ² (brickwall)	—	0.8	1.1	ps
Phase Noise, 156.25 MHz	ϕN	100 Hz	—	-72	—	dBc/Hz
		1 kHz	—	-93	—	dBc/Hz
		10 kHz	—	-114	—	dBc/Hz
		100 kHz	—	-123	—	dBc/Hz
		1 MHz	—	-136	—	dBc/Hz
Spurious	SPR	LVPECL output, 156.25 MHz, offset > 10 kHz	—	-75	—	dBc
Notes:						
1. Applies to output frequencies: 74.17582, 74.25, 75, 77.76, 100, 106.25, 125, 148.35165, 148.5, 150, 155.52, 156.25, 212.5, 250 MHz.						
2. Applies to output frequencies: 100, 106.25, 125, 148.35165, 148.5, 150, 155.52, 156.25, 212.5 and 250 MHz.						

Table 7. Output Clock Jitter and Phase Noise (HCSL)

$V_{DD} = 1.8\text{ V} \pm 5\%$, 2.5 or 3.3 V $\pm 10\%$, $T_A = -40$ to $+85\text{ }^\circ\text{C}$; Output Format = HCSL

Parameter	Symbol	Test Condition	Min	Typ	Max	Unit
Period Jitter (RMS)	JPRMS	10k samples*	—	—	1.2	ps
Period Jitter (Pk-Pk)	JPPKPK	10k samples*	—	—	11	ps
Phase Jitter (RMS)	ϕJ	1.875 MHz to 20 MHz integration bandwidth* (brickwall)	—	0.25	0.30	ps
		12 kHz to 20 MHz integration bandwidth* (brickwall)	—	0.8	1.0	ps
Phase Noise, 156.25 MHz	ϕN	100 Hz	—	-75	—	dBc/Hz
		1 kHz	—	-98	—	dBc/Hz
		10 kHz	—	-117	—	dBc/Hz
		100 kHz	—	-127	—	dBc/Hz
		1 MHz	—	-136	—	dBc/Hz
Spurious	SPR	LVPECL output, 156.25 MHz, offset > 10 kHz	—	-75	—	dBc

***Note:** Applies to an output frequency of 100 MHz.

Table 8. Output Clock Jitter and Phase Noise (CMOS, Dual CMOS)

$V_{DD} = 1.8\text{ V} \pm 5\%$, $2.5\text{ or }3.3\text{ V} \pm 10\%$, $T_A = -40\text{ to }+85\text{ }^\circ\text{C}$; Output Format = CMOS, Dual CMOS

Parameter	Symbol	Test Condition	Min	Typ	Max	Unit
Phase Jitter (RMS)	ϕ_J	1.875 MHz to 20 MHz integration bandwidth ² (brickwall)	—	0.25	0.35	ps
		12 kHz to 20 MHz integration bandwidth ² (brickwall)	—	0.8	1.1	ps
Phase Noise, 156.25 MHz	ϕ_N	100 Hz	—	-71	—	dBc/Hz
		1 kHz	—	-93	—	dBc/Hz
		10 kHz	—	-113	—	dBc/Hz
		100 kHz	—	-123	—	dBc/Hz
		1 MHz	—	-136	—	dBc/Hz
Spurious	SPR	LVPECL output, 156.25 MHz, offset > 10 kHz	—	-75	—	dBc

Notes:

1. Applies to output frequencies: 74.17582, 74.25, 75, 77.76, 100, 106.25, 125, 148.35165, 148.5, 150, 155.52, 156.25, 212.5 MHz.
2. Applies to output frequencies: 100, 106.25, 125, 148.35165, 148.5, 150, 155.52, 156.25, 212.5 MHz.

Table 9. Environmental Compliance and Package Information

Parameter	Conditions/Test Method
Mechanical Shock	MIL-STD-883, Method 2002
Mechanical Vibration	MIL-STD-883, Method 2007
Solderability	MIL-STD-883, Method 2003
Gross and Fine Leak	MIL-STD-883, Method 1014
Resistance to Solder Heat	MIL-STD-883, Method 2036
Contact Pads	Gold over Nickel

Table 10. Thermal Characteristics

Parameter	Symbol	Test Condition	Value	Unit
CLCC, Thermal Resistance Junction to Ambient	θ_{JA}	Still air	110	°C/W
2.5x3.2mm, Thermal Resistance Junction to Ambient	θ_{JA}	Still air	164	°C/W

Table 11. Absolute Maximum Ratings¹

Parameter	Symbol	Rating	Unit
Maximum Operating Temperature	T_{AMAX}	85	°C
Storage Temperature	T_S	-55 to +125	°C
Supply Voltage	V_{DD}	-0.5 to +3.8	V
Input Voltage (any input pin)	V_I	-0.5 to $V_{DD} + 0.3$	V
ESD Sensitivity (HBM, per JESD22-A114)	HBM	2	kV
Soldering Temperature (Pb-free profile) ²	T_{PEAK}	260	°C
Soldering Temperature Time at T_{PEAK} (Pb-free profile) ²	T_P	20–40	sec

Notes:

1. Stresses beyond those listed in this table may cause permanent damage to the device. Functional operation or specification compliance is not implied at these conditions. Exposure to maximum rating conditions for extended periods may affect device reliability.
2. The device is compliant with JEDEC J-STD-020E.

2. Solder Reflow and Rework Requirements for 2.5x3.2 mm Packages

Reflow of Silicon Labs' components should be done in a manner consistent with the IPC/JEDEC J-STD-20E standard. The temperature of the package is not to exceed the classification Temperature provided in the standard. The part should not be within -5°C of the classification or peak reflow temperature (T_{PEAK}) for longer than 30 seconds. Key to maintaining the integrity of the component is providing uniform heating and cooling of the part during reflow and rework. Uniform heating is achieved through having a preheat soak and controlling the temperature ramps in the process. J-STD-20E provides minimum and maximum temperatures and times for the preheat/Soak step that need to be followed, even for rework. The entire assembly area should be heated during rework. Hot air should be flowed from both the bottom of the board and the top of the component. Heating from the top only will cause un-even heating of component and can lead to part integrity issues. Temperature Ramp-up rate are not to exceed 3°C/second. Temperature ramp-down rates from peak to final temperature are not to exceed 6°C/second. Time from 25°C to peak temperature is not to exceed 8 min for Pb-free solders.

3. Pin Descriptions



Table 12. Si515 Pin Descriptions (CMOS)

Pin	Name	CMOS Function
1	V_C	Control Voltage Input.
2	OE	Output Enable. Internal pull-up for OE active high. Pull-down for OE active low. See ordering information.
3	GND	Electrical and Case Ground.
4	CLK	Clock Output.
5	NC	No connect. Make no external connection to this pin.
6	V_{DD}	Power Supply Voltage.

Table 13. Si515 Pin Descriptions (LVPECL/LVDS/HCSL/Dual CMOS)

Pin	Name	LVPECL/LVDS/HCSL/Dual CMOS Function
1	V_C	Control Voltage Input.
2	OE	Output Enable. Internal pull-up for OE active high. Pull-down for OE active low. See ordering information.
3	GND	Electrical and Case Ground.
4	CLK+	Clock Output.
5	CLK-	Complementary Clock Output.
6	V_{DD}	Power Supply Voltage.

3.1. Dual CMOS Buffer

Dual CMOS output format ordering options support either complementary or in-phase output signals. This feature enables replacement of multiple VCXOs with a single Si515 device.



Figure 1. Integrated 1:2 CMOS Buffer Supports Complementary or In-Phase Outputs

4. Ordering Information

The Si515 supports a variety of options including frequency, stability, tuning slope, output format, and V_{DD} . Specific device configurations are programmed into the Si515 at time of shipment. Configurations are specified using the Part Number Configuration chart shown below. Silicon Labs provides a web browser-based part number configuration utility to simplify this process. To access this tool refer to www.silabs.com/oscillators and click "Customize" in the product table. The Si515 VCXO series is supplied in industry-standard, RoHS compliant, lead-free, 2.5 x 3.2 mm, 3.2 x 5.0 mm, and 5 x 7 mm packages. Tape and reel packaging is an ordering option.



Figure 2. Part Number Convention

Example ordering part number: 515BBB212M500BAGR.

The series prefix, 515, indicates the device is a single frequency VCXO.

The 1st option code B specifies the output format is LVDS and powered from a 3.3 V supply. The stability and APR code B indicates a temperature stability of ±20 ppm with a tuning slope of ±120 ppm/V. The 3rd option code B specifies the OE pin is active low.

The frequency code is 212M500. Per this convention, and as indicated by the part number lookup utility at www.silabs.com/VCXOpartnumber, the output frequency is 212.5 MHz. The package code B refers to the 3.2 x 5 mm footprint with six pins. The last A refers to the product revision, G indicates the temperature range (-40 to +85 °C), and R specifies the device ships in tape and reel format.

Note: CMOS and Dual CMOS maximum frequency is 212.5 MHz.

5. Package Outline Diagram: 5 x 7 mm, 6-pin

Figure 3 illustrates the package details for the Si515. Table 14 lists the values for the dimensions shown in the illustration.



Figure 3. Si515 Outline Diagram

Table 14. Package Diagram Dimensions (mm)

Dimension	Min	Nom	Max
A	1.50	1.65	1.80
b	1.30	1.40	1.50
c	0.50	0.60	0.70
D	5.00 BSC.		
D1	4.30	4.40	4.50
e	2.54 BSC.		
E	7.00 BSC.		
E1	6.10	6.20	6.30
H	0.55	0.65	0.75
L	1.17	1.27	1.37
L1	0.05	0.10	0.15
p	1.80	—	2.60
R	0.7 REF.		
aaa	0.15		
bbb	0.15		
ccc	0.10		
ddd	0.10		
eee	0.05		
Notes:			
1. All dimensions shown are in millimeters (mm) unless otherwise noted.			
2. Dimensioning and Tolerancing per ANSI Y14.5M-1994.			

6. PCB Land Pattern: 5 x 7 mm, 6-pin

Figure 4 illustrates the 5 x 7 mm PCB land pattern for the Si515. Table 15 lists the values for the dimensions shown in the illustration.

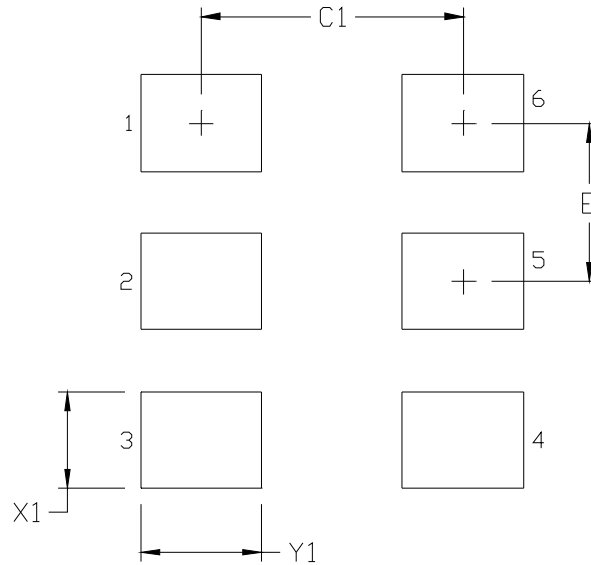

Figure 4. Si515 PCB Land Pattern

Table 15. PCB Land Pattern Dimensions (mm)

Dimension	(mm)
C1	4.20
E	5.08
X1	1.55
Y1	1.95

Notes:

General

1. All dimensions shown are in millimeters (mm) unless otherwise noted.
2. Dimensioning and Tolerancing is per the ANSI Y14.5M-1994 specification.
3. This Land Pattern Design is based on the IPC-7351 guidelines.
4. All dimensions shown are at Maximum Material Condition (MMC). Least Material Condition (LMC) is calculated based on a Fabrication Allowance of 0.05 mm.

Solder Mask Design

5. All metal pads are to be non-solder mask defined (NSMD). Clearance between the solder mask and the metal pad is to be 60 μm minimum, all the way around the pad.

Stencil Design

6. A stainless steel, laser-cut and electro-polished stencil with trapezoidal walls should be used to assure good solder paste release.
7. The stencil thickness should be 0.125 mm (5 mils).
8. The ratio of stencil aperture to land pad size should be 1:1.

Card Assembly

9. A No-Clean, Type-3 solder paste is recommended.
10. The recommended card reflow profile is per the JEDEC/IPC J-STD-020 specification for Small Body Components.

7. Package Outline Diagram: 3.2 x 5.0 mm, 6-pin

Figure 5 illustrates the package details for the 3.2 x 5 mm Si515. Table 16 lists the values for the dimensions shown in the illustration.

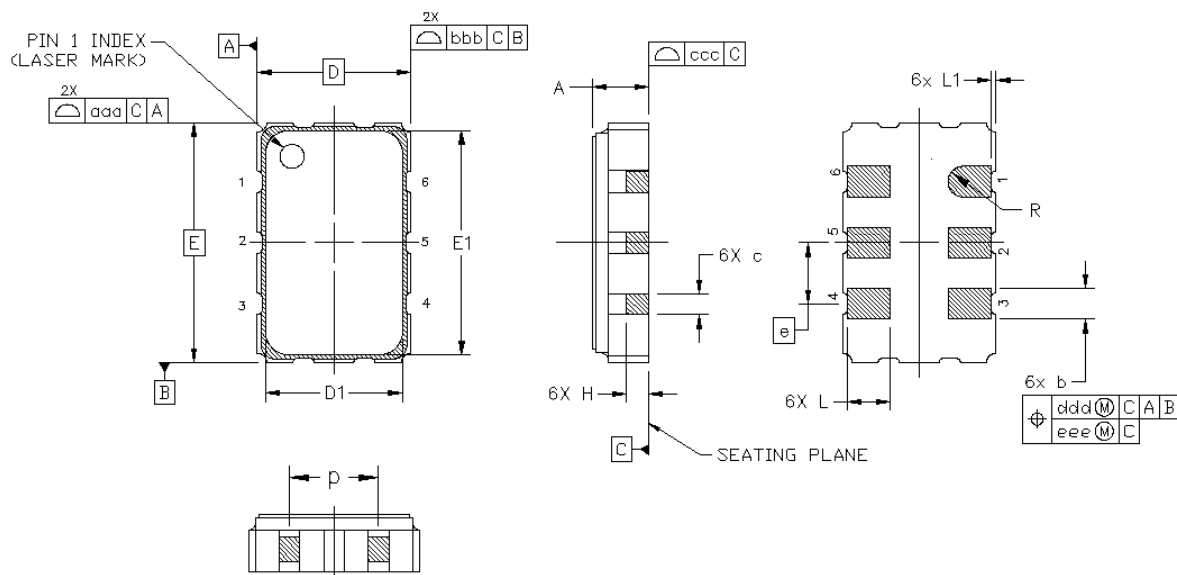

Figure 5. Si515 Outline Diagram

Table 16. Package Diagram Dimensions (mm)

Dimension	Min	Nom	Max
A	1.06	1.17	1.33
b	0.54	0.64	0.74
c	0.35	0.45	0.55
D	3.20 BSC		
D1	2.55	2.60	2.65
e	1.27 BSC		
E	5.00 BSC		
E1	4.35	4.40	4.45
H	0.45	0.55	0.65
L	0.80	0.90	1.00
L1	0.05	0.10	0.15
p	1.17	1.27	1.37
R	0.32 REF		
aaa	0.15		
bbb	0.15		
ccc	0.10		
ddd	0.10		
eee	0.05		
Notes:			
1. All dimensions shown are in millimeters (mm) unless otherwise noted.			
2. Dimensioning and Tolerancing per ANSI Y14.5M-1994.			

8. PCB Land Pattern: 3.2 x 5.0 mm, 6-pin

Figure 6 illustrates the recommended 3.2 x 5.0 mm PCB land pattern for the Si515. Table 17 lists the values for the dimensions shown in the illustration.



Figure 6. Si515 PCB Land Pattern

Table 17. PCB Land Pattern Dimensions (mm)

Dimension	(mm)
C1	2.60
E	1.27
X1	0.80
Y1	1.70

Notes:

General

1. All dimensions shown are in millimeters (mm) unless otherwise noted.
2. Dimensioning and Tolerancing is per the ANSI Y14.5M-1994 specification.
3. This Land Pattern Design is based on the IPC-7351 guidelines.
4. All dimensions shown are at Maximum Material Condition (MMC). Least Material Condition (LMC) is calculated based on a Fabrication Allowance of 0.05 mm.

Solder Mask Design

5. All metal pads are to be non-solder mask defined (NSMD). Clearance between the solder mask and the metal pad is to be 60 µm minimum, all the way around the pad.

Stencil Design

6. A stainless steel, laser-cut and electro-polished stencil with trapezoidal walls should be used to assure good solder paste release.
7. The stencil thickness should be 0.125 mm (5 mils).
8. The ratio of stencil aperture to land pad size should be 1:1.

Card Assembly

9. A No-Clean, Type-3 solder paste is recommended.
10. The recommended card reflow profile is per the JEDEC/IPC J-STD-020 specification for Small Body Components.

9. Package Outline Diagram: 2.5 x 3.2 mm, 6-pin

Figure 7 illustrates the package details for the 2.5 x 3.2 mm Si515. Table 18 lists the values for the dimensions shown in the illustration.



Figure 7. Si515 Outline Diagram

Table 18. Package Diagram Dimensions (mm)

Dimension	Min	Nom	Max
A	—	—	1.1
A1	0.26 REF		
A2	0.7 REF		
W	0.65	0.7	0.75
D	3.20 BSC		
e	1.25 BSC		
E	2.50 BSC		
M	0.30 BSC		
L	0.45	0.5	0.55
D1	2.5 BSC		
E1	1.65 BSC		
SE	0.825 BSC		
aaa	0.1		
bbb	0.2		
ddd	0.08		
Notes:			
1. All dimensions shown are in millimeters (mm) unless otherwise noted.			
2. Dimensioning and Tolerancing per ANSI Y14.5M-1994.			

10. PCB Land Pattern: 2.5 x 3.2 mm, 6-pin

Figure 8 illustrates the 2.5 x 3.2 mm PCB land pattern for the Si515. Table 19 lists the values for the dimensions shown in the illustration.



Figure 8. Si515 Recommended PCB Land Pattern

Table 19. PCB Land Pattern Dimensions (mm)

Dimension	(mm)
C1	1.9
E	2.50
X1	0.70
Y1	1.05

Notes:

General

- All dimensions shown are at Maximum Material Condition (MMC). Least Material Condition (LMC) is calculated based on a Fabrication Allowance of 0.05 mm.
- This Land Pattern Design is based on the IPC-7351 guidelines.

Solder Mask Design

- All metal pads are to be non-solder mask defined (NSMD). Clearance between the solder mask and the metal pad is to be 60 μm minimum, all the way around the pad.

Stencil Design

- A stainless steel, laser-cut and electro-polished stencil with trapezoidal walls should be used to assure good solder paste release.
- The stencil thickness should be 0.125 mm (5 mils).
- The ratio of stencil aperture to land pad size should be 1:1 for all perimeter pins.

Card Assembly

- A No-Clean, Type-3 solder paste is recommended.
- The recommended card reflow profile is per the JEDEC/IPC J-STD-020 specification for Small Body Components.

Si515

11. Top Marking

Use the part number configuration utility located at: www.silabs.com/VCXOPartNumber to cross-reference the mark code to a specific device configuration.

11.1. Si515 Top Marking



11.2. Top Marking Explanation

Mark Method:	Laser	
Line 1 Marking:	5 = Si515 CCCCC = Mark Code	5CCCCC
Line 2 Marking:	TTTTTT = Assembly Manufacturing Code	TTTTTT
Line 3 Marking:	Pin 1 indicator.	Circle with 0.5 mm diameter; left-justified
	YY = Year. WW = Work week. Characters correspond to the year and work week of package assembly.	YYWW

REVISION HISTORY

Revision 1.2

June, 2018

- Changed “Trays” to “Coil Tape” in Ordering Guide.

Revision 1.1

December, 2017

- Added 2.5 x 3.2 mm package.

Revision 1.0

- Updated Table 1 on page 3.
 - Updates to supply current typical and maximum values for CMOS, LVDS, LVPECL and HCSL.
 - CMOS frequency test condition corrected to 100 MHz.
 - Updates to OE VIH minimum and VIL maximum values.
- Updated Table 3 on page 4.
 - Dual CMOS nominal frequency maximum added.
 - Disable time maximum values updated.
 - Enable time parameter added.
- Updated Table 4 on page 5.
 - CMOS output rise / fall time typical and maximum values updated.
 - LVPECL/HCSL output rise / fall time maximum value updated.
 - LVPECL output swing maximum value updated.
 - LVDS output common mode typical and maximum values updated.
 - HCSL output swing maximum value updated.
 - Duty cycle minimum and maximum values tightened to 48/52%.
- Updated Table 5 on page 6.
 - Phase jitter test condition, typical and maximum value updated.
 - Phase noise typical values updated.
 - Additive RMS jitter due to external power supply noise typical values updated.
- Added Tables 6, 7, 8 for LVDS, HCSL, CMOS and Dual CMOS operations.
- Added note to Figure 2 clarifying CMOS and Dual CMOS maximum frequency.
- Updated Figure 5 outline diagram to correct pinout.
- Updated “11. Top Marking” section and moved to page 22.



ClockBuilder Pro

One-click access to Timing tools, documentation, software, source code libraries & more. Available for Windows and iOS (CBGo only).

www.silabs.com/CBPro



Timing Portfolio
www.silabs.com/timing



SW/HW
www.silabs.com/CBPro



Quality
www.silabs.com/quality



Support and Community
community.silabs.com

Disclaimer

Silicon Labs intends to provide customers with the latest, accurate, and in-depth documentation of all peripherals and modules available for system and software implementers using or intending to use the Silicon Labs products. Characterization data, available modules and peripherals, memory sizes and memory addresses refer to each specific device, and "Typical" parameters provided can and do vary in different applications. Application examples described herein are for illustrative purposes only. Silicon Labs reserves the right to make changes without further notice to the product information, specifications, and descriptions herein, and does not give warranties as to the accuracy or completeness of the included information. Without prior notification, Silicon Labs may update product firmware during the manufacturing process for security or reliability reasons. Such changes will not alter the specifications or the performance of the product. Silicon Labs shall have no liability for the consequences of use of the information supplied in this document. This document does not imply or expressly grant any license to design or fabricate any integrated circuits. The products are not designed or authorized to be used within any FDA Class III devices, applications for which FDA premarket approval is required or Life Support Systems without the specific written consent of Silicon Labs. A "Life Support System" is any product or system intended to support or sustain life and/or health, which, if it fails, can be reasonably expected to result in significant personal injury or death. Silicon Labs products are not designed or authorized for military applications. Silicon Labs products shall under no circumstances be used in weapons of mass destruction including (but not limited to) nuclear, biological or chemical weapons, or missiles capable of delivering such weapons. Silicon Labs disclaims all express and implied warranties and shall not be responsible or liable for any injuries or damages related to use of a Silicon Labs product in such unauthorized applications.

Trademark Information

Silicon Laboratories Inc.®, Silicon Laboratories®, Silicon Labs®, SiLabs® and the Silicon Labs logo®, Bluegiga®, Bluegiga Logo®, ClockBuilder®, CMEMS®, DSPLL®, EFM®, EFM32®, EFR®, Ember®, Energy Micro, Energy Micro logo and combinations thereof, "the world's most energy friendly microcontrollers", Ember®, EZLink®, EZRadio®, EZRadioPRO®, Gecko®, Gecko OS, Gecko OS Studio, ISOModem®, Precision32®, ProSLIC®, Simplicity Studio®, SiPHY®, Telegesis, the Telegesis Logo®, USBXpress®, Zentri, the Zentri logo and Zentri DMS, Z-Wave®, and others are trademarks or registered trademarks of Silicon Labs. ARM, CORTEX, Cortex-M3 and THUMB are trademarks or registered trademarks of ARM Holdings. Keil is a registered trademark of ARM Limited. Wi-Fi is a registered trademark of the Wi-Fi Alliance. All other products or brand names mentioned herein are trademarks of their respective holders.



Silicon Laboratories Inc.
400 West Cesar Chavez
Austin, TX 78701
USA

<http://www.silabs.com>

Компания «Океан Электроники» предлагает заключение долгосрочных отношений при поставках импортных электронных компонентов на взаимовыгодных условиях!

Наши преимущества:

- Поставка оригинальных импортных электронных компонентов напрямую с производств Америки, Европы и Азии, а так же с крупнейших складов мира;
- Широкая линейка поставок активных и пассивных импортных электронных компонентов (более 30 млн. наименований);
- Поставка сложных, дефицитных, либо снятых с производства позиций;
- Оперативные сроки поставки под заказ (от 5 рабочих дней);
- Экспресс доставка в любую точку России;
- Помощь Конструкторского Отдела и консультации квалифицированных инженеров;
- Техническая поддержка проекта, помощь в подборе аналогов, поставка прототипов;
- Поставка электронных компонентов под контролем ВП;
- Система менеджмента качества сертифицирована по Международному стандарту ISO 9001;
- При необходимости вся продукция военного и аэрокосмического назначения проходит испытания и сертификацию в лаборатории (по согласованию с заказчиком);
- Поставка специализированных компонентов военного и аэрокосмического уровня качества (Xilinx, Altera, Analog Devices, Intersil, Interpoint, Microsemi, Actel, Aeroflex, Peregrine, VPT, Syfer, Eurofarad, Texas Instruments, MS Kennedy, Miteq, Cobham, E2V, MA-COM, Hittite, Mini-Circuits, General Dynamics и др.);

Компания «Океан Электроники» является официальным дистрибьютором и эксклюзивным представителем в России одного из крупнейших производителей разъемов военного и аэрокосмического назначения «JONHON», а так же официальным дистрибьютором и эксклюзивным представителем в России производителя высокотехнологичных и надежных решений для передачи СВЧ сигналов «FORSTAR».



JONHON

«JONHON» (основан в 1970 г.)

Разъемы специального, военного и аэрокосмического назначения:

(Применяются в военной, авиационной, аэрокосмической, морской, железнодорожной, горно- и нефтедобывающей отраслях промышленности)

«FORSTAR» (основан в 1998 г.)

ВЧ соединители, коаксиальные кабели, кабельные сборки и микроволновые компоненты:

(Применяются в телекоммуникациях гражданского и специального назначения, в средствах связи, РЛС, а так же военной, авиационной и аэрокосмической отраслях промышленности).



Телефон: 8 (812) 309-75-97 (многоканальный)

Факс: 8 (812) 320-03-32

Электронная почта: ocean@oceanchips.ru

Web: <http://oceanchips.ru/>

Адрес: 198099, г. Санкт-Петербург, ул. Калинина, д. 2, корп. 4, лит. А