

# IS31LT3352

## 40V LED DRIVER WITH TEMPERATURE COMPENSATION

OCTOBER 2011

### GENERAL DESCRIPTION

The IS31LT3352 is a continuous mode inductive step-down converter, designed for driving a single LED or multiple series connected LEDs efficiently from a voltage source higher than the required LED voltage. The chip operates from an input supply between 6V and 40V and provides an externally adjustable output current of up to 750mA. Depending upon supply voltage and external components, this can provide up to 30 watts of output power.

The IS31LT3352 includes an integrated output switch and a high-side output current sensing circuit, which uses an external resistor to set the nominal average output current.

The IS31LT3352 integrates temperature compensation function in order to maintain LEDs' stable and reliable operation. The IS31LT3352 measures the thermistance mounted close to LEDs. When ambient temperature near LEDs goes too high and the Negative Temperature Coefficient thermistors reach the value of threshold resistance connected at R<sub>TH</sub> pin, output current starts to reduce automatically. After the ambient temperature falls down to a safe temperature, the current will return to the set value.

The IS31LT3352 can be connected as LED drivers' chain with the same temperature compensation percentage. In this chain, every IS31LT3352's ADJO output pin drives next stage's IS31LT3352's ADJI input pin with temperature compensation information. So, only one thermistor is needed in the whole IS31LT3352 system.

### FEATURES

- Simple low parts count
- Internal 40V power switch
- Wide input voltage range: 6V to 40V
- Up to 750mA output current
- High efficiency (up to 95% )
- 1200 : 1 dimming ratio
- Typical 5% output current accuracy
- Single pin on/off and brightness control using DC voltage or PWM
- Up to 1MHz switching frequency
- Inherent open-circuit LED protection
- Thermal shutdown to protect IC itself
- Temperature compensation to protect LEDs

### APPLICATIONS

- Low voltage halogen replacement LEDs
- Automotive lighting
- Low voltage industrial lighting
- LED back-up lighting
- Illuminated signs

### APPLICATION CIRCUIT

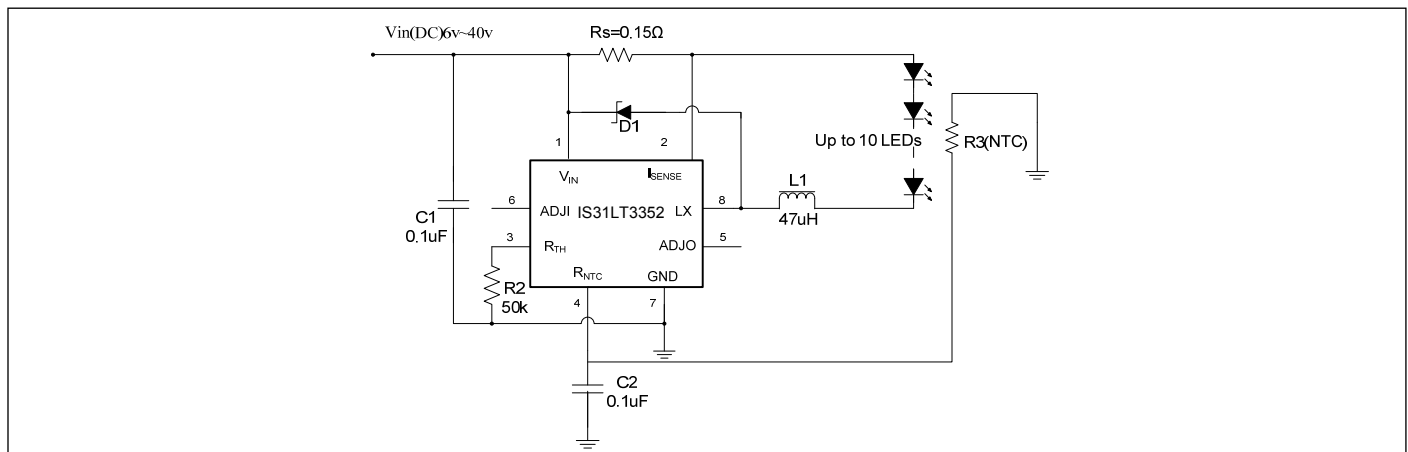

Copyright © 2011 Integrated Silicon Solution, Inc. All rights reserved. ISSI reserves the right to make changes to this specification and its products at any time without notice. ISSI assumes no liability arising out of the application or use of any information, products or services described herein. Customers are advised to obtain the latest version of this device specification before relying on any published information and before placing orders for products. Integrated Silicon Solution, Inc. does not recommend the use of any of its products in life support applications where the failure or malfunction of the product can reasonably be expected to cause failure of the life support system or to significantly affect its safety or effectiveness. Products are not authorized for use in such applications unless Integrated Silicon Solution, Inc. receives written assurance to its satisfaction, that:

- a.) the risk of injury or damage has been minimized;
- b.) the user assume all such risks; and
- c.) potential liability of Integrated Silicon Solution, Inc is adequately protected under the circumstances

# IS31LT3352

## SYSTEM APPLICATION

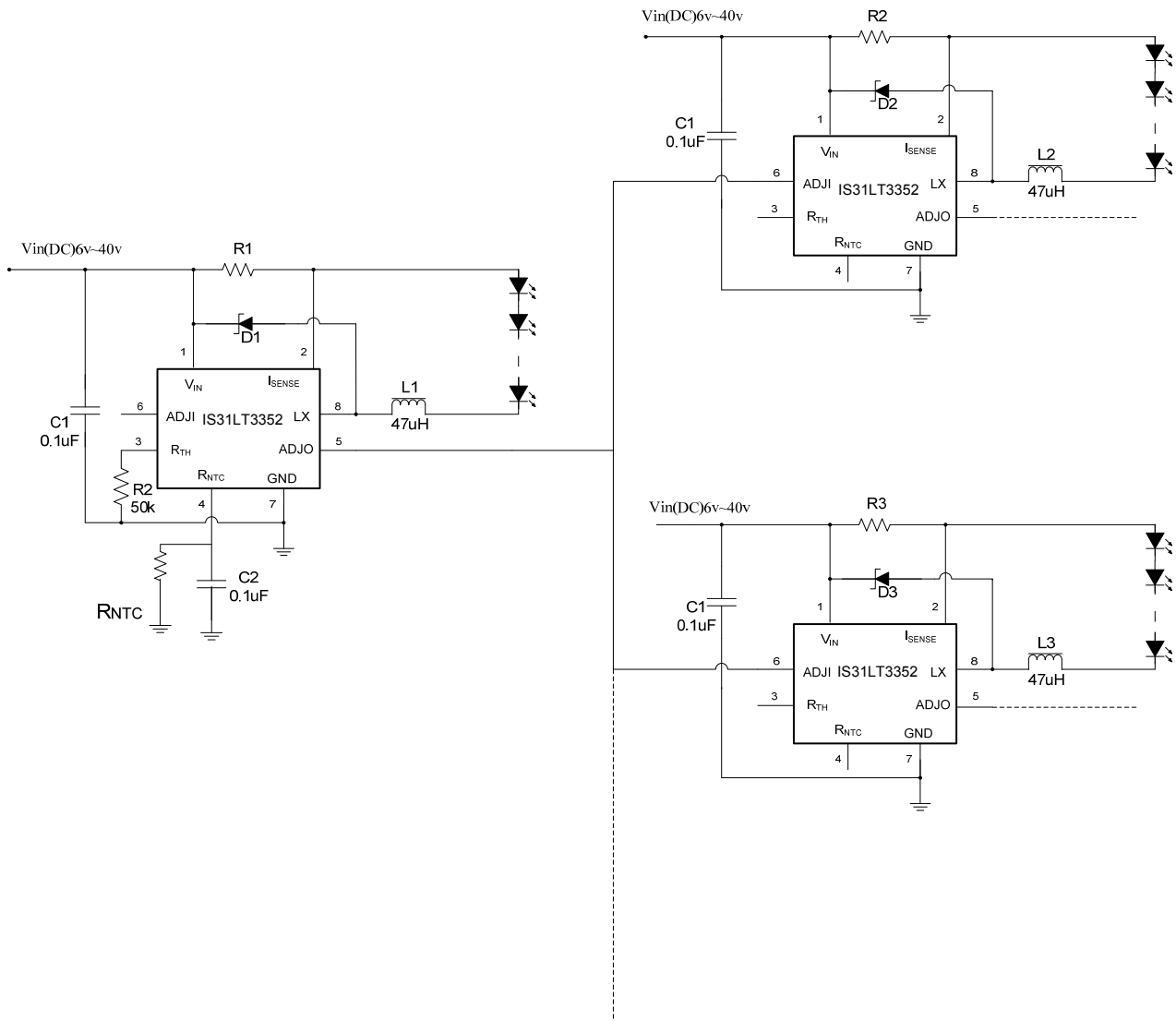

**Note:**

Each IS31LT3352 can driver up to three slave chips in the next stages, and it is recommend no more than three stages are used for the current coherence, therefore, up to thirteen IS31LT3352s are allowed in one system

# IS31LT3352

## PIN CONFIGURATIONS

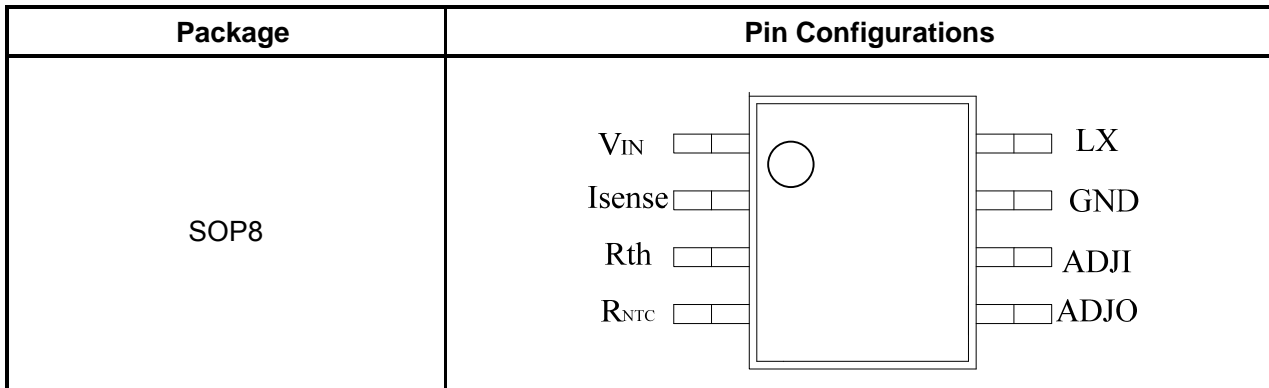

## PIN DESCRIPTION

Pin Name	NO.	Description
V <sub>IN</sub>	1	Input voltage (6V to 40V). Decouple to ground with 1μF or higher X7R ceramic capacitor close to device
I <sub>SENSE</sub>	2	Connect resistor R <sub>S</sub> from this pin to V <sub>IN</sub> to define nominal average output current I <sub>OUTnom</sub> = 0.1/R <sub>S</sub>
R <sub>TH</sub>	3	The pin set the starting temperature of temperature compensation by connecting an external resistor.
R <sub>NTC</sub>	4	The output currents reduction slope set pin by connecting an external thermistor in temperature compensation mode.
ADJO	5	LED drivers chain application pin. * When R <sub>3</sub> (NTC) > R <sub>2</sub> , V <sub>ADJO</sub> = V <sub>ADJI</sub> * When R <sub>3</sub> (NTC) < R <sub>2</sub> , ADJO pin outputs ADJI voltage with temperature compensation information $V_{ADJO} = V_{ADJI} * R_3 / R_2$
ADJI	6	Multi-function On/Off and brightness control pin: * Leave floating for normal operation. (V <sub>ADJI</sub> = V <sub>REF</sub> = 1.2V giving nominal average output current I <sub>OUTnom</sub> = 0.1/R <sub>S</sub> ) * Drive to voltage below 0.2V to turn off output current * Drive with DC voltage (0.3V < V <sub>ADJI</sub> < 1.2V) to adjust output current from 25% to 100% of I <sub>OUTnom</sub> * Drive with PWM signal to adjust output current. * When driving the ADJI pin above 1.2V, the current will be clamped to 100% brightness automatically.
GND	7	Ground (0V)
LX	8	Drain of power switch



# IS31LT3352

---

## ORDERING INFORMATION

Industrial Range: -40°C to +85°C

Order Number	Quantity per reel	Package	V <sub>SENSE</sub>
IS31LT3352-V1GRLS2-TR	2,500	SOP-8, Lead-free	91mV to 101mV
IS31LT3352-V2GRLS2-TR	2,500	SOP-8, Lead-free	99mV to 110mV

# IS31LT3352

## ABSOLUTE MAXIMUM RATINGS (NOTE 1)

Symbol	Parameter	Rating
$V_{IN}$	Input voltage	-0.3V to +50V
$V_{ISENSE}$	$I_{SENSE}$ voltage	$V_{IN}+0.3V$ to $V_{IN}-5V$ , $V_{IN}>5V$
		$V_{IN}+0.3V$ to $-0.3V$ , $V_{IN}<5V$
$V_{LX}$	LX output voltage	-0.3V to +50V
$V_{ADJ}$ , $V_{ADJO}$ , $R_{th}$ , $R_{NTC}$	Pin input voltage	-0.3V to +6V
$I_{LX}$	Switch output current	800mA
$P_{tot}$	Power dissipation	1.2W
$T_{OP}$	Operating temperature	-40 to 85°C
$T_{ST}$	Storage temperature	-55 to 150°C
$T_{JMAX}$	Junction temperature	150°C
$R_{\theta JA}$	Junction to ambient	80°C/W
	ESD Susceptibility(human body mode)	2kV

## ELECTRICAL CHARACTERISTICS

( $V_{IN}=12V$ ,  $T_{amb}=25^{\circ}C$  unless otherwise stated) (NOTE 2)

Symbol	Parameter	Conditions	Min.	Typ.	Max.	Unit	
$V_{IN}$	Input voltage		6		40	V	
$I_{INQoff}$	Quiescent supply current with output off	ADJI pin grounded	40	60	80	$\mu A$	
$I_{INQon}$	Quiescent supply current with output switching	ADJI pin floating		450	600	$\mu A$	
$V_{ISENSE}$	Mean current sense threshold voltage	Measured on $I_{SENSE}$ pin with respect to $V_{IN}$ ADJI pin floating	IS31LT3352-V1	91	95	101	mV
			IS31LT3352-V2	99	105	110	
$V_{SENSEHYS}$	Sense threshold hysteresis			$\pm 15$		%	
$I_{SENSE}$	$I_{SENSE}$ pin input current	$V_{SENSE} = 0.1V$		8	10	$\mu A$	
$V_{REF}$	Internal reference voltage	Measured on ADJI pin with pin floating		1.2		V	
$V_{ADJI}$	External control voltage range on ADJI pin for dc brightness control		0.3		1.2	V	
$V_{ADJloff}$	DC voltage on ADJI pin to switch chip from active (on) state to quiescent (off) state	$V_{ADJI}$ falling	0.15	0.2	0.25	V	
$V_{ADJlon}$	DC voltage on ADJI pin to switch chip from quiescent (off) state to active (on) state	$V_{ADJI}$ rising	0.2	0.25	0.3	V	
$V_{OS}$	$R_{TH}$ and $R_{NTC}$ pin offset voltage			10		mV	

# IS31LT3352

## ELECTRICAL CHARACTERISTICS

(VIN=12V, Tamb=25°C unless otherwise stated) (NOTE 2) (continued)

Symbol	Parameter	Conditions	Min.	Typ.	Max.	Unit
$I_{LX(leak)}$	LX switch leakage current				1	$\mu A$
$V_{ADJO}$	ADJO terminal voltage	No temperature compensation ADJI pin floating $I_{ADJO}=30\mu A$		1.20		V
$R_{LX}$	LX Switch 'On' resistance			0.9	1.5	$\Omega$
$I_{LXmean}$	Continuous LX switch current			0.65		A
$R_{ADJI}$	Resistance between ADJI pin and VREF			500		K $\Omega$
$D_{PWM(LF)}$	Brightness control range at low frequency PWM signal	PWM frequency =100Hz PWM amplitude=5V, Vin=15V, L=27uH, Driving 1 LED		1200:1		
$D_{PWM(HF)}$	Brightness control range at high frequency PWM signal	PWM frequency =10kHz PWM amplitude=5V, Vin=15V, L=27uH, Driving 1 LED		13:1		
$f_{LX}$	Operating frequency	ADJI pin floating L=100 $\mu H$ (0.82 $\Omega$ ) $I_{OUT}=350mA$ @ $V_{LED}=3.4V$ Driving 1 LED		154		KHz
$V_{ADJO}$ to $V_{ADJI}$ offset	ADJI pin to ADJO pin drift voltage		-38		38	mV
$T_{ONmin}$	Minimum switch 'ON' time	LX switch 'ON'		200		ns
$T_{OFFmin}$	Minimum switch 'OFF' time	LX switch 'OFF'		200		ns
$f_{LXmax}$	Recommended maximum operating frequency				1	MHz
$D_{LX}$	Recommended duty cycle range of output switch at $f_{LXmax}$		0.3	0.7	0.9	
$T_{PD}$	Internal comparator propagation delay			50		ns
$T_{SD}$	Thermal shutdown temperature			140		$^{\circ}C$
$T_{SD-HYS}$	Thermal shutdown hysteresis			20		$^{\circ}C$

### NOTES:

- Stresses beyond those listed under absolute maximum ratings may cause permanent damage to the device. These are stress ratings only, and functional operation of the device at these or any other conditions beyond those indicated under recommended operating conditions is not implied. Exposure to absolute-maximum-rated conditions for extended periods may affect device reliability.
- All parts are production tested at TA=25°C. Other temperature limits are guaranteed by design.

# IS31LT3352

## TYPICAL OPERATING CONDITIONS

For typical application circuit, at  $T_{amb}=25^{\circ}\text{C}$  unless otherwise stated.

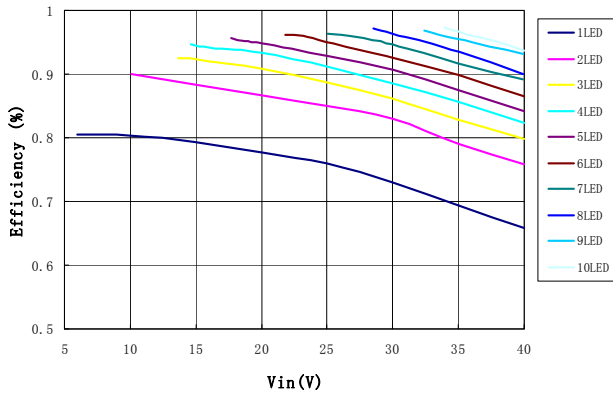

**Efficiency vs. No. of LEDs**  
**L=100uH, Rs=0.33Ohm**

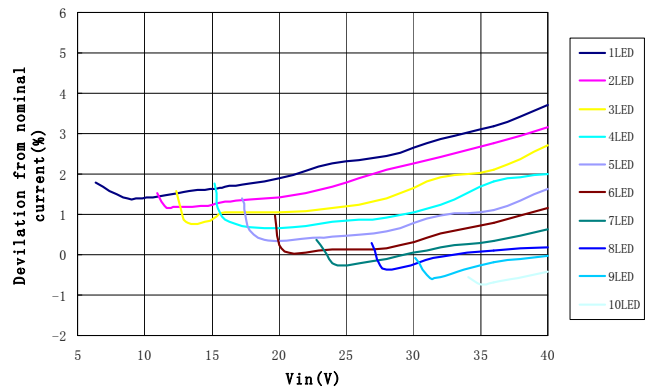

**Output current variation with Supply Voltage**  
**L=100uH, Rs=0.33Ohm**

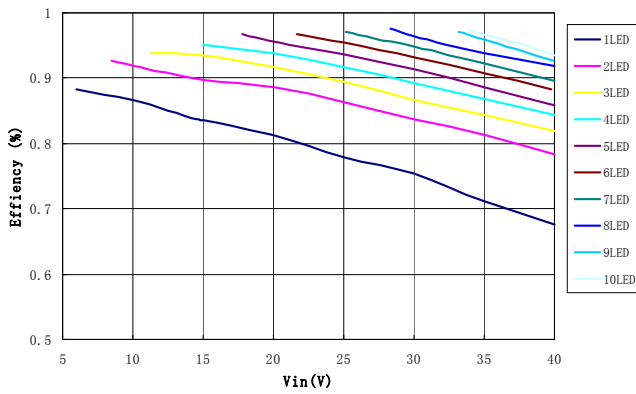

**Efficiency vs. No. of LEDs**  
**L=47uH, Rs=0.33Ohm**

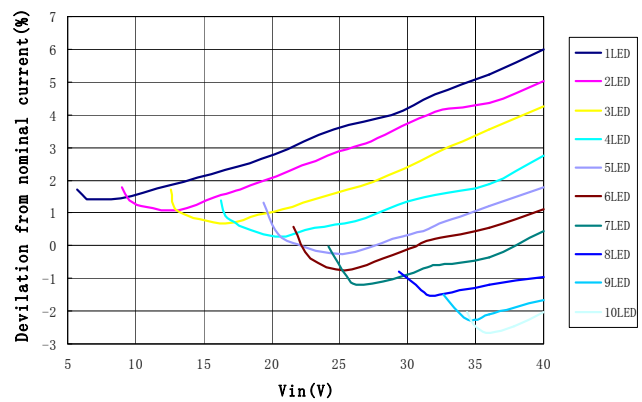

**Output current variation with Supply Voltage**  
**L=47uH, Rs=0.33Ohm**

# IS31LT3352

## Typical operating conditions (continued)

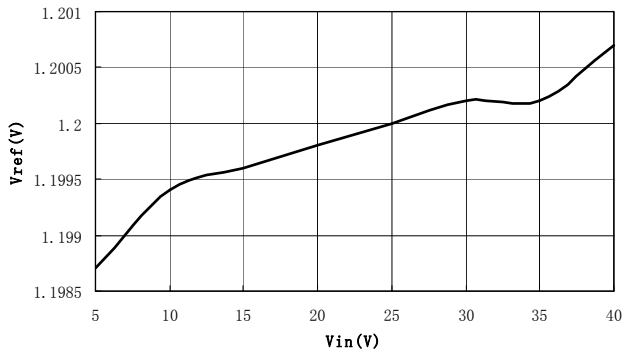

Vref vs. Vin over nominal supply voltage range

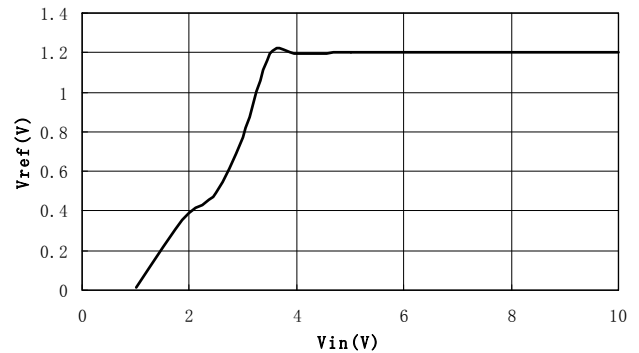

Vref vs. Vin at low supply voltage

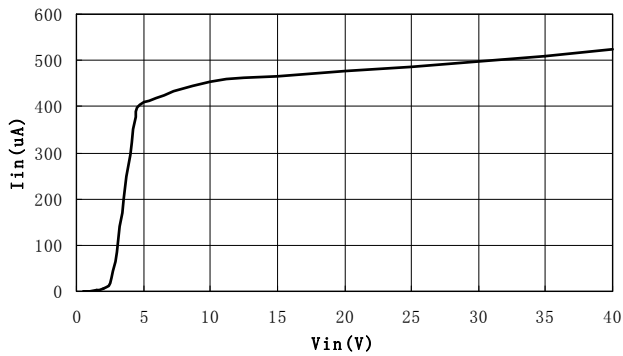

Supply Current vs. Vin (Operating)

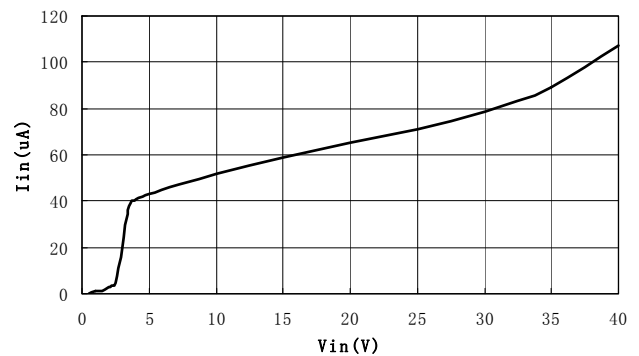

Shutdown Current vs. Vin (Quiescent)

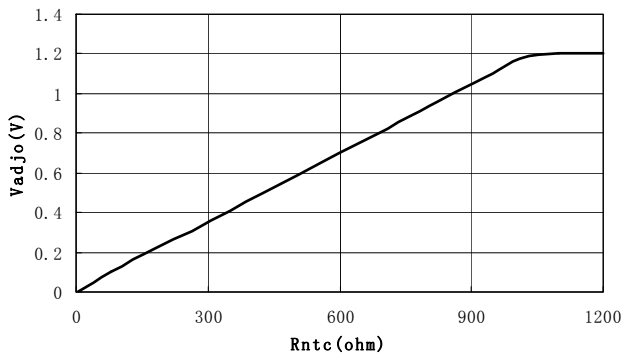

Vadjo vs. Rntc  
Rntc falling, Rth=1kohm



# IS31LT3352

## APPLICATION INFORMATION

### Setting nominal average output current with external resistor $R_S$

The nominal average output current in the LED(s) is determined by the value of the external current sense resistor ( $R_S$ ) connected between  $V_{IN}$  and  $I_{SENSE}$  and is given by:

$$I_{OUT\ nom} = 0.1/R_S \text{ [for } R_S > 0.13\Omega \text{]}$$

The table below gives values of nominal average output current for several preferred values of current setting resistor ( $R_S$ ) in the typical application circuit shown on page 1:

$R_S$ ( $\Omega$ )	Nominal average output current (mA)
0.13	769
0.15	667
0.27	370
0.3	333

$V_{sense}$  is divided into two ranges to improve current accuracy, please refer to bin information on page 4. The above values assume that the ADJI pin is floating and at a nominal voltage of  $V_{REF} = 1.2V$ . Note that  $R_S = 0.13\Omega$  is the minimum allowed value of sense resistor under these conditions to maintain switch current below the specified maximum value. It is possible to use different values of  $R_S$  if the ADJI pin is driven from an external voltage.

### Output current adjustment by external DC control voltage

The ADJI pin can be driven by an external dc voltage ( $V_{ADJI}$ ), as shown, to adjust the output current to a value below the nominal average value defined by  $R_S$ .

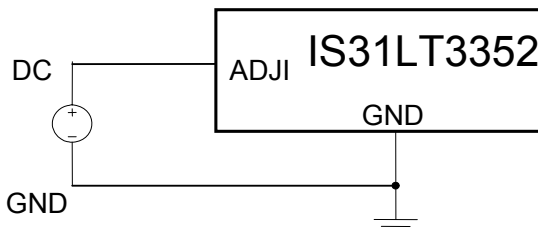

The nominal average output current in this case is given by:

$$I_{OUTdc} = 0.083 * V_{ADJI} / R_S \text{ [for } 0.3V < V_{ADJI} < 1.2V \text{]}$$

Note that 100% brightness setting corresponds to  $V_{ADJI} = V_{REF}$ . When driving the ADJI pin above 1.2V, the current will be clamped to 100% brightness automatically. The input impedance of the ADJI pin is  $500k \pm 25\%$ .

### Output current adjustment by PWM control Directly driving ADJI input

A Pulse Width Modulated (PWM) signal with duty cycle  $D_{PWM}$  can be applied to the ADJI pin, as shown below, to adjust the output current to a value below the nominal average value set by resistor  $R_S$ , the signal range from 0V~5V. The PWM signal must have the driving ability to drive an internal 500K $\Omega$  pull-up resistor.

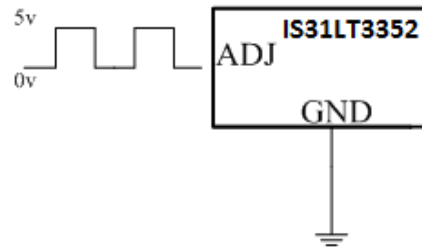

### Driving the ADJI input from a microcontroller

Another possibility is to drive the chip from the open drain output of a microcontroller. The diagram below shows one method of doing this:

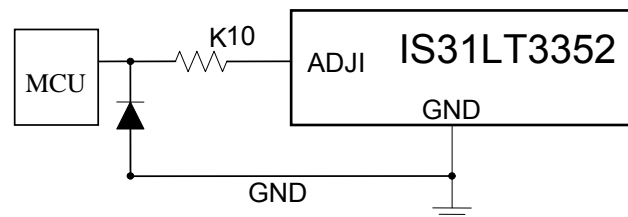

The diode and resistor suppress possible high amplitude negative spikes on the ADJI input resulting from the drain-source capacitance of the FET. Negative spikes at the input to the chip should be avoided as they may cause errors in output current or erratic device operation.

### Shutdown mode

Taking the ADJI pin to a voltage below 0.2V will turn off the output and supply current will fall to a low standby level of 60 $\mu A$  nominally.

### Inherent open-circuit LED protection

If the connection to the LED(s) is open-circuited, the coil is isolated from the LX pin of the chip, so the chip will not be damaged, unlike in many boost converters, where the back EMF may damage the internal switch by forcing the drain above its breakdown voltage.

### Capacitor selection

A low ESR capacitor should be used for input decoupling, as the ESR of this capacitor appears in series with the supply source impedance and lowers overall efficiency. This capacitor has to supply the relatively high peak current to the coil and smooth the current ripple on the input supply.

# IS31LT3352

If the source is a DC supply, the capacitor is decided by ripple of the source, the value is given by:

$$C_{\min} = \frac{I_F * T_{on}}{\Delta U_{MAX}}$$

$I_F$  is the value of output current,  $\Delta U_{MAX}$  is the ripple of power supply.  $T_{on}$  is the "ON" time of MOSFET. The value is normally 2 times of the minimum value.

If the source is an AC supply, typical output voltages ripple from a nominal 12V AC transformer can be  $\pm 10\%$ . If the input capacitor value is lower than 200 $\mu$ F, the AC input

waveform is distorted, sometimes the lowest value will be lower than the forward voltage of LED strings. This will lower the average current of the LEDs. So it is recommended to set the value of the capacitor bigger than 200 $\mu$ F.

For maximum stability over temperature and voltage, capacitors with X7R, X5R, or better dielectric are recommended. Capacitors with Y5V dielectric are not suitable for decoupling in this application and should not be used.

## Inductor selection

Recommended inductor values for the IS31LT3352 are in the range 47 $\mu$ H to 220 $\mu$ H.

Higher values of inductance are recommended at higher supply voltages and low output current in order to minimize errors due to switching delays, which result in increased ripple and lower efficiency. Higher values of inductance also result in a smaller change in output current over the supply voltage range. (See graphs). The inductor should be mounted as close to the chip as possible with low resistance connections to the LX and  $V_{IN}$  pins.

The chosen coil should have a saturation current higher than the peak output current and a continuous current rating above the required mean output current. It is recommended to use inductor with saturation current bigger than 1.2A for 700mA output current and inductor with saturation current bigger than 500mA for 350mA output current.

The inductor value should be chosen to maintain operating duty cycle and switch 'on/off' times within the specified limits over the supply voltage and load current range.

The following equations can be used as a guide.

## LX Switch 'On' time

$$T_{ON} = \frac{L\Delta I}{V_{IN} - V_{LED} - I_{AVG}(R_S + rL + R_{LX})}$$

**Note:**  $T_{ONmin} > 200ns$

## LX Switch 'Off' time

$$T_{OFF} = \frac{L\Delta I}{V_{LED} + V_D + I_{AVG}(rL + R_S)}$$

**Note:**  $T_{OFFmin} > 200ns$

## Where:

L is the coil inductance (H)

$r_L$  is the coil resistance ( $\Omega$ )

$I_{avg}$  is the required LED current (A)

$\Delta I$  is the coil peak-peak ripple current (A) {Internally set to  $0.3 \times I_{avg}$ }

$V_{IN}$  is the supply voltage (V)

$V_{LED}$  is the total LED forward voltage (V)

$R_{LX}$  is the switch resistance ( $\Omega$ )

$V_D$  is the diode forward voltage at the required load current (V)

## Example:

For  $V_{IN}=12V$ ,  $L=47\mu H$ ,  $r_L=0.64\Omega$ ,  $V_{LED}=3.4V$ ,  $I_{avg}=333mA$  and  $V_D=0.36V$

$T_{ON} = (47e-6 \times 0.105)/(12 - 3.4 - 0.612) = 0.62\mu s$

$T_{OFF} = (47e-6 \times 0.105)/(3.4 + 0.36 + 0.322) = 1.21\mu s$

This gives an operating frequency of 546kHz and a duty cycle of 0.34.

Optimum performance will be achieved by setting the duty cycle close to 0.5 at the nominal supply voltage. This helps to equalize the undershoot and overshoot and improves temperature stability of the output current.

## Diode selection

For maximum efficiency and performance, the rectifier (D1) should be a fast low capacitance Schottky diode with low reverse leakage at the maximum operating voltage and temperature.

If alternative diodes are used, it is important to select parts with a peak current rating above the peak coil current and a continuous current rating higher than the maximum output load current. It is very important to consider the reverse leakage of the diode when operating above 85°C. Excess leakage will increase the power dissipation in the device.

The higher forward voltage and overshoot due to reverse recovery time in silicon diodes will increase the peak voltage on the LX output. If a silicon diode is used, care should be taken to ensure that the total voltage appearing on the LX pin including supply ripple, does not exceed the specified maximum value.

## Reducing output ripple

Peak to peak ripple current in the LED can be reduced, if required, by shunting a capacitor  $C_{led}$  across the LED(s) as shown below:

# IS31LT3352

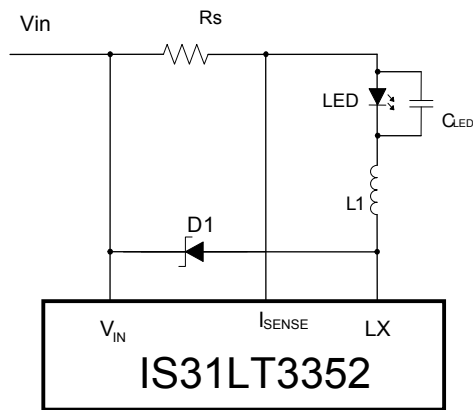

A value of 1 $\mu$ F will reduce nominal ripple current by a factor three (approx.). Proportionally lower ripple can be achieved with higher capacitor values. Note that the capacitor will not affect operating frequency or efficiency, but it will increase start-up delay, by reducing the rate of rise of LED voltage.

### Operation at low supply voltage

The internal regulator disables the drive to the switch until the supply has risen above the startup threshold set internally which makes power MOSFET on-resistance small enough. Above this threshold, the chip will start to operate. However, with the supply voltage below the specified minimum value, the switch duty cycle will be high and the chip power dissipation will be at a maximum. Care should be taken to avoid operating the chip under such conditions in the application, in order to minimize the risk of exceeding the maximum allowed die temperature. (See next section on **thermal considerations**).

Note that when driving loads of two or more LEDs, the forward drop will normally be sufficient to prevent the chip from switching below approximately 6V. This will minimize the risk of damage to the chip.

### Thermal considerations

When operating the chip at high ambient temperatures, or when driving maximum load current, care must be taken to avoid exceeding the package power dissipation limits. Note that the chip power dissipation will most often be a maximum at minimum supply voltage. It will also increase if the efficiency of the circuit is low. This may result from the use of unsuitable coils, or excessive parasitic output capacitance on the switch output.

### Temperature compensation of output current

High luminance LEDs often need to be supplied with a temperature compensated current in order to maintain stable and reliable operation at all drive levels. The LEDs are usually mounted remotely from the chip. For this reason, the temperature coefficients of the internal circuits for the IS31LT3352 have been optimized to

minimize the change in output current when no compensation is employed. If output current compensation is required, it is possible to use an external temperature sensing network - normally using Negative Temperature Coefficient (NTC) thermistors and/or diodes, mounted very close to the LED(s). The output of the sensing network can reduce output current with increasing temperature through internal circuit.

As shown in the figure below, the temperature compensation curve is decided by R1, NTC thermistor R2 and resistor R3. When LED(s) temperature increases, thermistance of R2 starts to reduce. As R2 reduces to the point that R2's thermistance plus R3 resistance equaling to R1 resistance, temperature compensation function starts to work and lout starts to reduce. The lout current with temperature compensation's equation is:

**In the case that 0.3 < V<sub>ADJ</sub>I < 1.2V:**

$$I_{OUTdc} = 0.083 * V_{ADJ} (R2+R3) / R1 * RS$$

**In the case that V<sub>ADJ</sub>I > 1.2V:**

$$I_{OUTdc} = 0.1 * (R2+R3) / R1 * RS$$

R2 and R3 decide the temperature compensation slope, if R3 is just 0ohm, slope is only decided by thermistor R2's parameter B-constant. And larger R3's resistance results in slope more even.

If the temperature compensation threshold is selected, larger R2 and R3 selected need larger R1 to match and vice versa. Too large R1 make R<sub>th</sub> pin more sensitive to noise, too small R1 will make IC current consumption larger. From 1K to 100K of R1 is recommended.

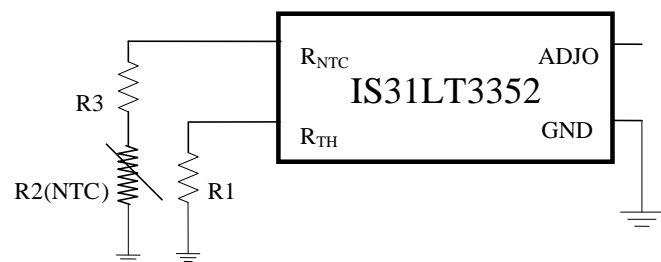

An IS31LT3352 calculator is available from the ISSI to assist with temperature compensation design and here are some detail examples as below:

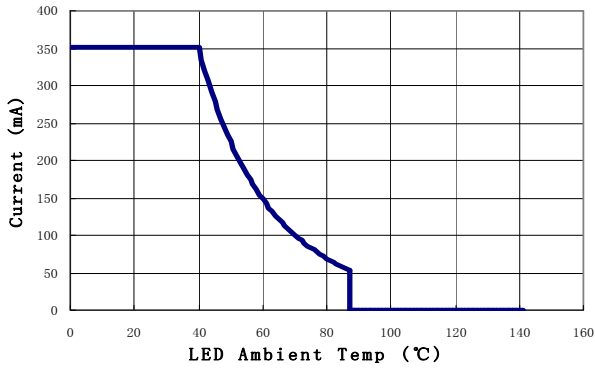

**B=4485, R1=48.6k, R2=100k, R3=0R**

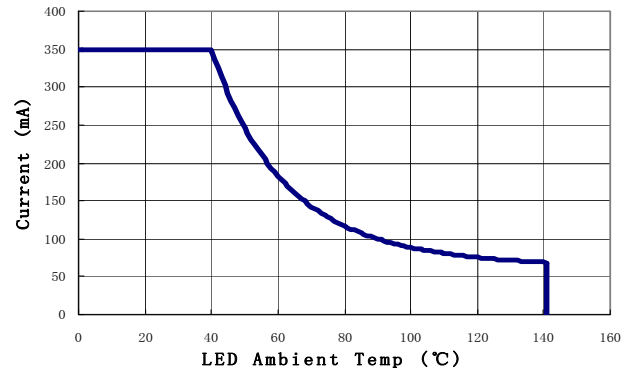

**B=4485, R1=58.6k, R2=100k, R3=10k**

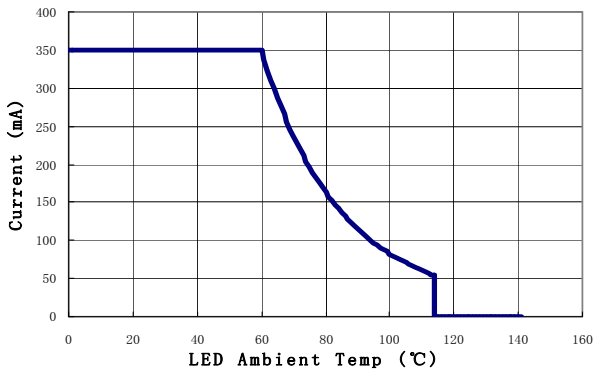

**B=4485, R1=20.6k, R2=100k, R3=0R**

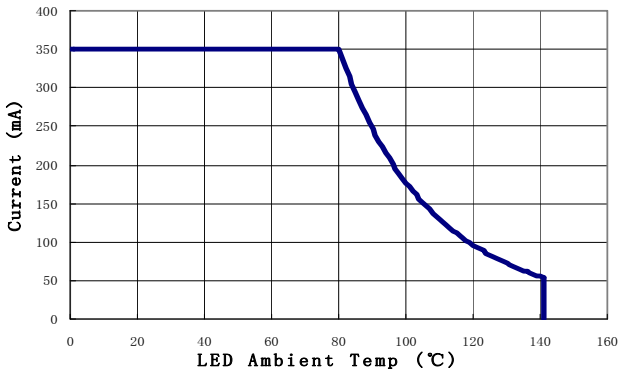

**B=4485, R1=22.1k, R2=220k, R3=0R**

# IS31LT3352

## LAYOUT CONSIDERATIONS

### LX pin

The LX pin of the chip is a fast switching node, so PCB traces should be kept as short as possible. To minimize ground 'bounce', the ground pin of the chip should be soldered directly to the ground plane.

### Coil and decoupling capacitors

It is particularly important to mount the coil and the input decoupling capacitor close to the chip to minimize parasitic resistance and inductance, which will degrade efficiency. It is also important to take account of any trace resistance in series with current sense resistor RS.

### High voltage traces

Avoid running any high voltage traces close to the ADJI pin, to reduce the risk of leakage due to board contamination. Any such leakage may raise the ADJI pin voltage and cause excessive output current. A ground ring placed around the ADJI pin will minimize changes in output current under these conditions

### ADJI pin

The ADJI pin is a high impedance input, so when left floating, PCB traces to this pin should be as short as possible to reduce noise pickup. The ADJI pin is a high impedance input, so when left floating, PCB traces to this pin should be as short as possible to reduce noise pickup. ADJI pin can also be connected to a voltage between 1.2V~5V. In this case, the internal circuit will clamp the output current at the value which is set by  $ADJI=1.2V$ .

### RTH, RNTC pin

The PCB trace from R1 to RTH pin should be as short as possible to reduce noise pickup. Because NTC thermistor R2 is mounted close to the LEDs and remote from IS31LT3352, the PCB trace from R2 to R<sub>NTC</sub> pin will be longer and pick up noise more easily. A 0.1uF capacitor from R<sub>NTC</sub> pin to ground and close to the R<sub>NTC</sub> pin is recommended to filter the frequency noise and provide protection against high voltage transients.

### ADJO pin

Because ADJO pin drives next stages, ADJI pins and the PCB trace may be longer which picks up noise easily. In this case 200pF (max) capacitor is needed to connect from ADJO trace to ground to filter out the noise. Best practice is to connect one capacitor respectively close to ADJO output pin and the next stage ADJI input pins, but the total capacitance besides the parasitic capacitance from ADJO pin to ground must be less than 200pF. Please refer to the connection as below.

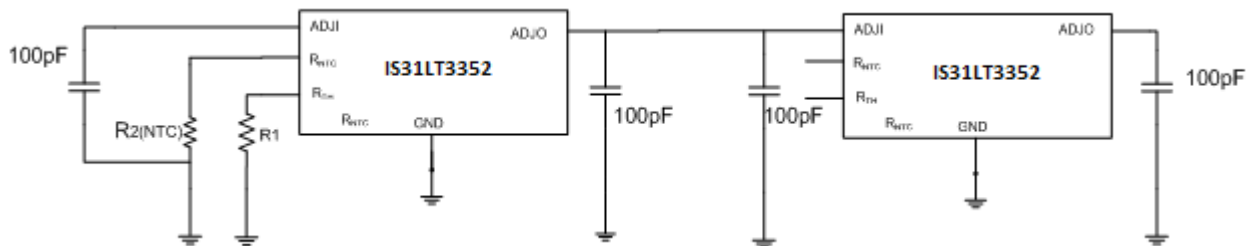

# IS31LT3352



## PACKAGE INFORMATION SOP-8

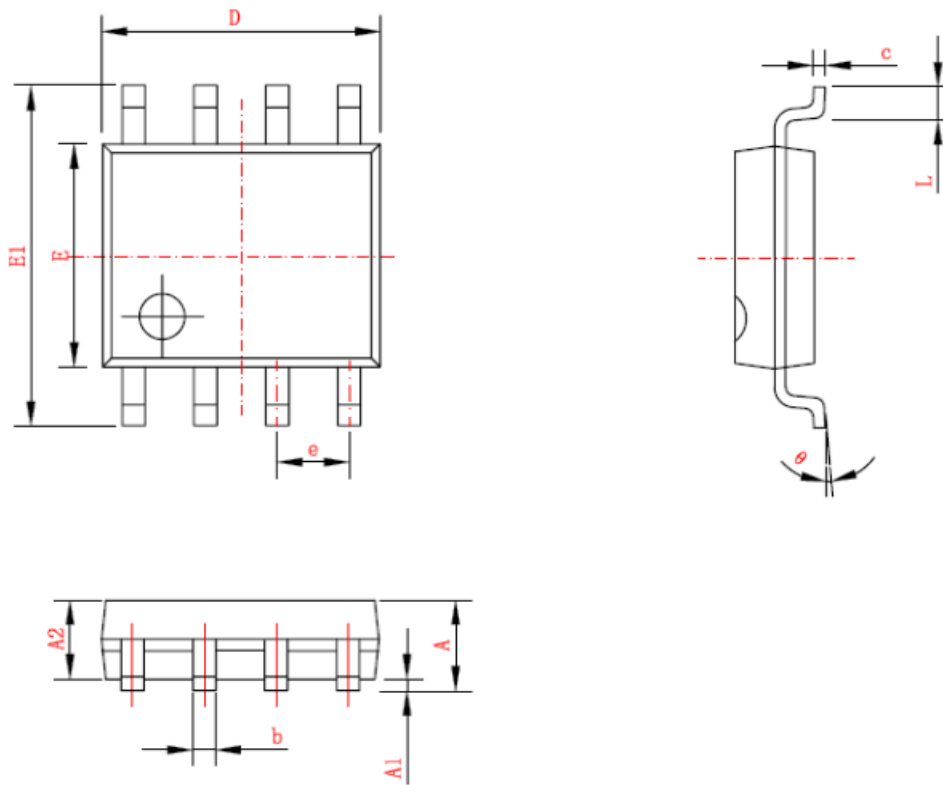

Symbol	Dimensions In Millimeters		Dimensions In Inches	
	Min	Max	Min	Max
A	1.350	1.750	0.053	0.069
A1	0.100	0.250	0.004	0.010
A2	1.450TYP		0.057TYP	
b	0.350	0.490	0.014	0.019
c	0.178	0.250	0.007	0.010
D	4.800	5.000	0.189	0.197
E	3.800	4.000	0.150	0.157
E1	5.800	6.240	0.228	0.246
e	1.270TYP		0.050TYP	
L	0.400	1.270	0.016	0.050
θ	0°	8°		

Компания «Океан Электроники» предлагает заключение долгосрочных отношений при поставках импортных электронных компонентов на взаимовыгодных условиях!

Наши преимущества:

- Поставка оригинальных импортных электронных компонентов напрямую с производств Америки, Европы и Азии, а так же с крупнейших складов мира;
- Широкая линейка поставок активных и пассивных импортных электронных компонентов (более 30 млн. наименований);
- Поставка сложных, дефицитных, либо снятых с производства позиций;
- Оперативные сроки поставки под заказ (от 5 рабочих дней);
- Экспресс доставка в любую точку России;
- Помощь Конструкторского Отдела и консультации квалифицированных инженеров;
- Техническая поддержка проекта, помощь в подборе аналогов, поставка прототипов;
- Поставка электронных компонентов под контролем ВП;
- Система менеджмента качества сертифицирована по Международному стандарту ISO 9001;
- При необходимости вся продукция военного и аэрокосмического назначения проходит испытания и сертификацию в лаборатории (по согласованию с заказчиком);
- Поставка специализированных компонентов военного и аэрокосмического уровня качества (Xilinx, Altera, Analog Devices, Intersil, Interpoint, Microsemi, Actel, Aeroflex, Peregrine, VPT, Syfer, Eurofarad, Texas Instruments, MS Kennedy, Miteq, Cobham, E2V, MA-COM, Hittite, Mini-Circuits, General Dynamics и др.);

Компания «Океан Электроники» является официальным дистрибьютором и эксклюзивным представителем в России одного из крупнейших производителей разъемов военного и аэрокосмического назначения «JONHON», а так же официальным дистрибьютором и эксклюзивным представителем в России производителя высокотехнологичных и надежных решений для передачи СВЧ сигналов «FORSTAR».



## JONHON

«JONHON» (основан в 1970 г.)

Разъемы специального, военного и аэрокосмического назначения:

(Применяются в военной, авиационной, аэрокосмической, морской, железнодорожной, горно- и нефтедобывающей отраслях промышленности)

«FORSTAR» (основан в 1998 г.)

ВЧ соединители, коаксиальные кабели, кабельные сборки и микроволновые компоненты:

(Применяются в телекоммуникациях гражданского и специального назначения, в средствах связи, РЛС, а так же военной, авиационной и аэрокосмической отраслях промышленности).



Телефон: 8 (812) 309-75-97 (многоканальный)

Факс: 8 (812) 320-03-32

Электронная почта: [ocean@oceanchips.ru](mailto:ocean@oceanchips.ru)

Web: <http://oceanchips.ru/>

Адрес: 198099, г. Санкт-Петербург, ул. Калинина, д. 2, корп. 4, лит. А