



SANYO Semiconductors

# DATA SHEET

An ON Semiconductor Company

## LV8773

Bi-CMOS LSI

# PWM Constant-Current Control Stepping Motor Driver

## Overview

The LV8773 is a 2-channel H-bridge driver IC, which supports forward, reverse, brake, and standby of a motor. It is ideally suited for driving brushed DC motors and stepping motors used in office equipment and amusement applications.

## Features

- BiCDMOS process IC
- Low on resistance (upper side : 0.3Ω ; lower side : 0.25Ω ; total of upper and lower : 0.55Ω ; Ta = 25°C, IO = 2A)
- Motor current selectable in two steps
- Output short-circuit protection circuit (selectable from latch-type or auto-reset-type) incorporated
- Unusual condition warning output pins
- No control power supply required

## Specifications

**Absolute Maximum Ratings** at Ta = 25°C

Parameter	Symbol	Conditions	Ratings	Unit
Supply voltage	VM max		36	V
Output peak current	IO peak	tw ≤ 10ms, duty 20%	2.5	A
Output current	IO max		2	A
Logic input voltage	VIN		-0.3 to +6	V
EMO1/EMO2 input voltage	Vemo/Vemo2		-0.3 to +6	V
Allowable power dissipation	Pd max1	1 unit	3.0	W
	Pd max2	*	6.2	W
Operating temperature	Topr		-20 to +85	°C
Storage temperature	Tstg		-55 to +150	°C

\* Specified circuit board : 90.0mm×90.0mm×1.6mm, glass epoxy 2-layer board.

■ Any and all SANYO Semiconductor Co.,Ltd. products described or contained herein are, with regard to "standard application", intended for the use as general electronics equipment (home appliances, AV equipment, communication device, office equipment, industrial equipment etc.). The products mentioned herein shall not be intended for use for any "special application" (medical equipment whose purpose is to sustain life, aerospace instrument, nuclear control device, burning appliances, transportation machine, traffic signal system, safety equipment etc.) that shall require extremely high level of reliability and can directly threaten human lives in case of failure or malfunction of the product or may cause harm to human bodies, nor shall they grant any guarantee thereof. If you should intend to use our products for applications outside the standard applications of our customer who is considering such use and/or outside the scope of our intended standard applications, please consult with us prior to the intended use. If there is no consultation or inquiry before the intended use, our customer shall be solely responsible for the use.

■ Specifications of any and all SANYO Semiconductor Co.,Ltd. products described or contained herein stipulate the performance, characteristics, and functions of the described products in the independent state, and are not guarantees of the performance, characteristics, and functions of the described products as mounted in the customer's products or equipment. To verify symptoms and states that cannot be evaluated in an independent device, the customer should always evaluate and test devices mounted in the customer's products or equipment.

**SANYO Semiconductor Co., Ltd.**

<http://semicon.sanyo.com/en/network>

# LV8773

## Allowable Operating Ratings at Ta = 25°C

Parameter	Symbol	Conditions	Ratings	Unit
Supply voltage range	VM		9 to 32	V
Logic input voltage	V <sub>IN</sub>		0 to 5.5	V
VREF input voltage range	VREF		0 to 3	V

## Electrical Characteristics at Ta = 25°C, VM = 24V, VREF = 1.5V

Parameter	Symbol	Conditions	Ratings			Unit
			min	typ	max	
Standby mode current drain	IMst	ST = "L"		100	400	μA
Current drain	IM	ST = "H", OE = "L", with no load		3.2	5	mA
VREG5 output voltage	Vreg5	I <sub>O</sub> = -1mA	4.5	5	5.5	V
Thermal shutdown temperature	TSD	Design guarantee	150	180	200	°C
Thermal hysteresis width	ΔTSD	Design guarantee		40		°C
<b>Motor driver</b>						
Output on resistance	Ron <sub>u</sub>	I <sub>O</sub> = 2A, Upper-side on resistance		0.3	0.4	Ω
	Ron <sub>d</sub>	I <sub>O</sub> = 2A, Lower-side on resistance		0.25	0.33	Ω
Output leakage current	I <sub>Oleak</sub>				50	μA
Diode forward voltage	VD	ID = -2A		1.2	1.4	V
Logic pin input current	I <sub>INL</sub>	V <sub>IN</sub> = 0.8V	4	8	12	μA
	I <sub>INH</sub>	V <sub>IN</sub> = 5V	30	50	70	μA
Logic high-level input voltage	V <sub>INH</sub>		2.0			V
Logic low-level input voltage	V <sub>INL</sub>				0.8	V
Current setting comparator threshold voltage (current attenuation rate switching)	Vtatt0	ATT = L	0.291	0.3	0.309	V
	Vtatt1	ATT = H	0.143	0.15	0.157	V
Chopping frequency	Fchop	Cchop = 220pF	36.3	45.4	54.5	kHz
CHOP pin charge/discharge current	I <sub>chop</sub>		7	10	13	μA
Chopping oscillation circuit threshold voltage	V <sub>tup</sub>		0.8	1	1.2	V
	V <sub>t<sub>down</sub></sub>		0.4	0.5	0.6	V
VREF pin input current	I <sub>ref</sub>	VREF = 1.5V	-0.5			μA
<b>Charge pump</b>						
VG output voltage	VG		28	28.7	29.8	V
Rise time	t <sub>ONG</sub>	VG = 0.1μF		200		μS
Oscillator frequency	Fosc		90	125	150	kHz
<b>Output short-circuit protection</b>						
EMO1/EMO2 pin saturation voltage	V <sub>satemo</sub>	I <sub>emo</sub> = 1mA			400	mV
CEM pin charge current	I <sub>cem</sub>	V <sub>cem</sub> = 0V	7	10	13	μA
CEM pin threshold voltage	V <sub>t<sub>cem</sub></sub>		0.8	1	1.2	V

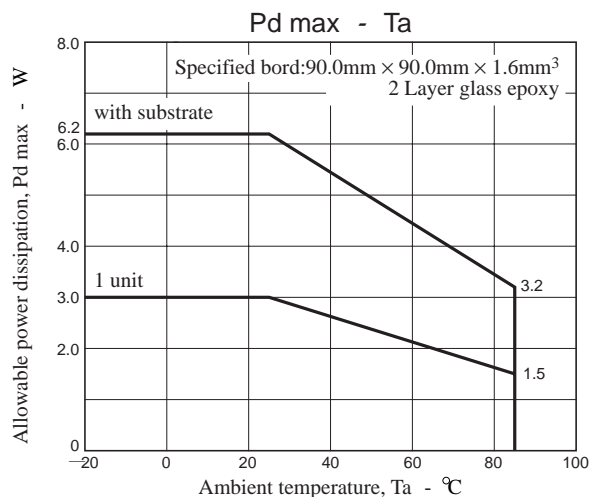

# LV8773

## Package Dimensions

unit : mm (typ)

3241A

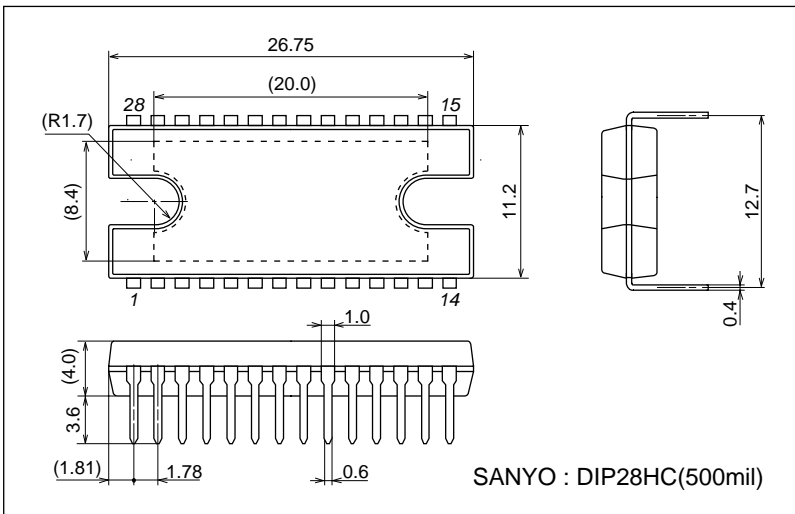

## Pin Assignment

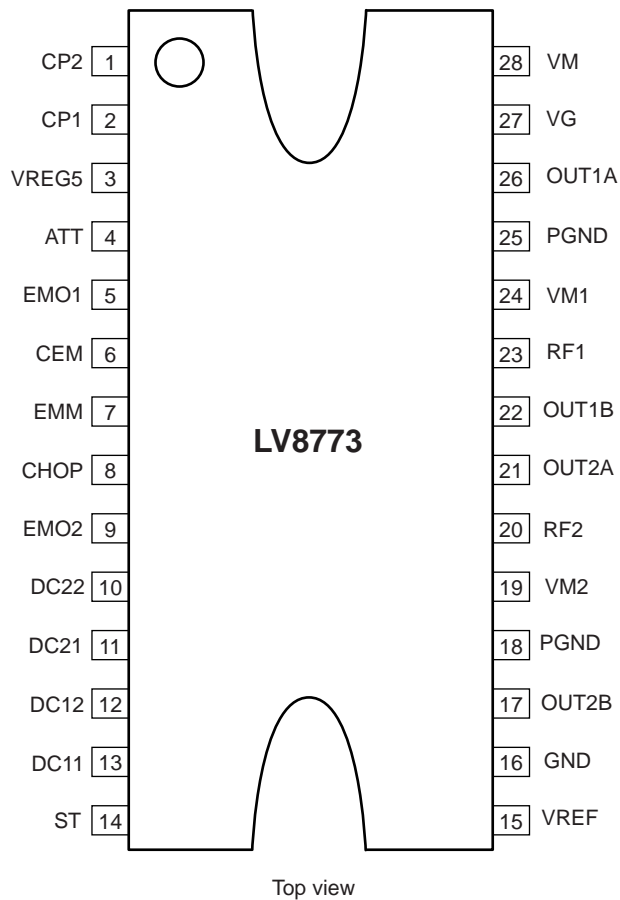

Block Diagram

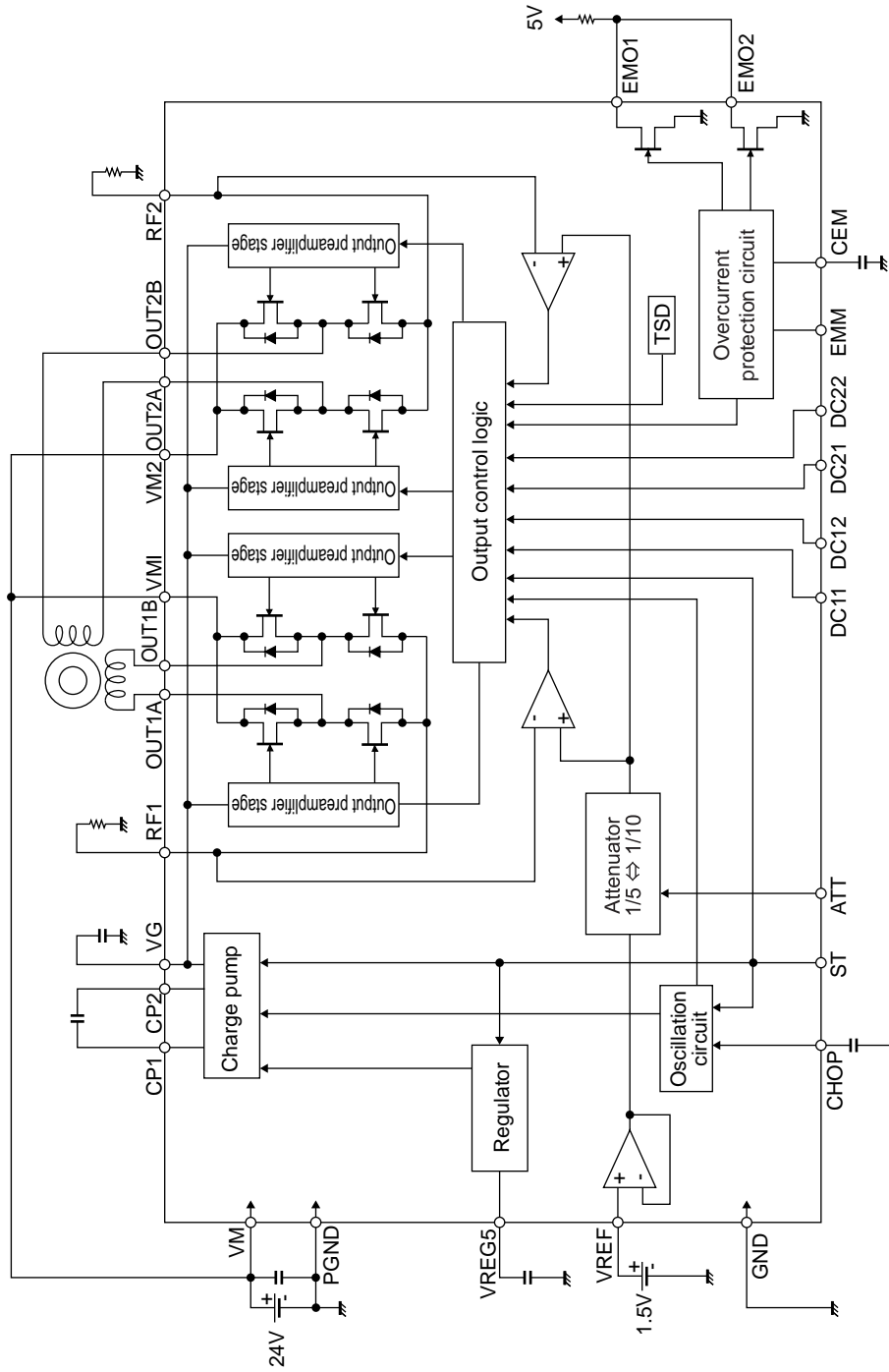

# LV8773

## Pin Functions

Pin No.	Pin Name	Pin Function	Equivalent Circuit
4 7 10 11 12 13	ATT2 EMM DC22 DC21 DC12 DC11	Motor holding current switching pin. Output short-circuit protection mode switching pin. Channel 2 output control input pin 2 Channel 2 output control input pin 1 Channel 1 output control input pin 2 Channel 1 output control input pin 1	
14	ST	Chip enable pin.	
17 18, 25 19 20 21 22 23 24 26	OUT2B PGND VM2 RF2 OUT2A OUT1B RF1 VM1 OUT1A	Channel 2 OUTB output pin. Power system ground. Channel 2 motor power supply connection pin. Channel 2 current-sense resistor connection pin. Channel 2 OUTA output pin. Channel 1 OUTB output pin. Channel 1 current-sense resistor connection pin. Channel 1 motor power supply pin. Channel 1 OUTA output pin.	
27 28 1 2	VG VM CP2 CP1	Charge pump capacitor connection pin. Motor power supply connection pin. Charge pump capacitor connection pin. Charge pump capacitor connection pin.	
16	GND	Ground.	

Continued on next page.

# LV8773

Continued from preceding page.

Pin No.	Pin Name	Pin Function	Equivalent Circuit
15	VREF	Constant current control reference voltage input pin.	
3	VREG5	Internal power supply capacitor connection pin.	
5 9	EMO1 EMO2	Channel 1 output short-circuit state warning output pin. Channel 2 output short-circuit state warning output pin.	
6	CEM	Pin to connect the output short-circuit state detection time setting capacitor	
8	CHOP	Copping frequency setting capacitor connection pin.	

**Description of operation**

(1) Chip enable function

This IC is switched between standby and operating mode by setting the ST pin. In standby mode, the IC is set to power-save mode and all logic is reset. In addition, the internal regulator circuit and charge pump circuit do not operate in standby mode.

ST	Mode	Internal regulator	Charge pump
Low or Open	Standby mode	Standby	Standby
High	Operating mode	Operating	Operating

(2) Output control logic

input		output		mode
DC11(21)	DC12(22)	OUT1(2)A	OUT1(2)B	
L	L	OFF	OFF	Stand-by
H	L	H	L	CW ( Forward )
L	H	L	H	CCW ( reverse )
H	H	L	L	brake

(3) Blanking period

If, when exercising PWM constant-current chopping control over the motor current, the mode is switched from decay to charge, the recovery current of the parasitic diode may flow to the current sensing resistance, causing noise to be carried on the current sensing resistance pin, and this may result in erroneous detection. To prevent this erroneous detection, a blanking period is provided to prevent the noise occurring during mode switching from being received. During this period, the mode is not switched from charge to decay even if noise is carried on the current sensing resistance pin.

This IC is the blanking time is fixed at approximately 2μs.

(4) Chopping frequency setting

For constant-current control, this IC performs chopping operations at the frequency determined by the capacitor (Cchop) connected between the CHOP pin and GND.

The chopping frequency is set as shown below by the capacitor (Cchop) connected between the CHOP pin and GND.

$$F_{chop} = I_{chop} / (C_{chop} \times V_{tchop} \times 2) \text{ (Hz)}$$

$I_{chop}$  : Capacitor charge/discharge current, typ 10μA

$V_{tchop}$  : Charge/discharge hysteresis voltage ( $V_{tup} - V_{tdown}$ ), typ 0.5V

For instance, when Cchop is 220pF, the chopping frequency will be as follows :

$$F_{chop} = 10\mu A / (220pF \times 0.5V \times 2) = 45.4kHz$$

(5) Setting constant-current control

When the current of the motor reaches up to a set current by setting the output current, this IC does the short brake control by the automatic operation so that the current should not increase more than it.

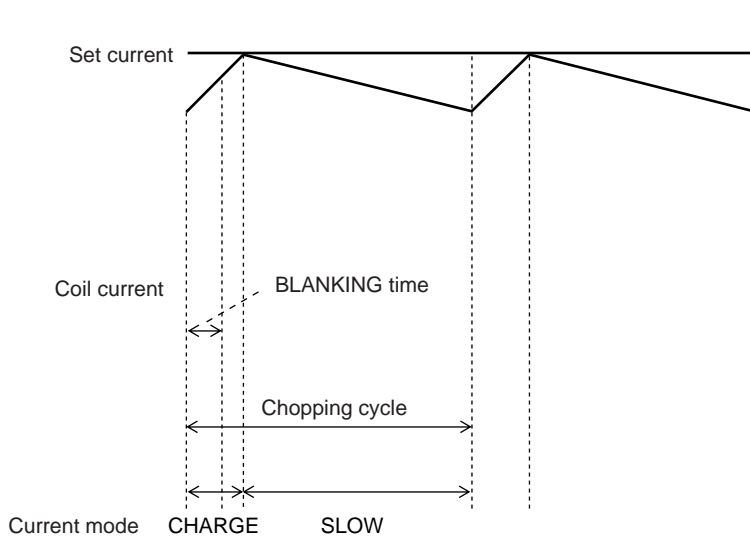

Based on the voltage input to the VREF pin and the resistance connected between RF and GND, the output current that is subject to the constant-current control is set using the calculation formula below :

$$I_{OUT} = (VREF/5)/RF \text{ resistance}$$

\* The above setting is the output current at 100% of each excitation mode.

The voltage input to the VREF pin can be switched to two-step settings depending on the statuses of the ATT.

Attenuation function for VREF input voltage

ATT	Current setting reference voltage attenuation ratio
Low	100%
High	50%

The formula used to calculate the output current when using the function for attenuating the VREF input voltage is given below.

$$I_{OUT} = (VREF/5) \times (\text{attenuation ratio})/RF \text{ resistance}$$

Example : At VREF of 1.5V, a reference voltage setting of 100% (ATT = L) and an RF resistance of 0.3Ω, the output current is set as shown below.

$$I_{OUT} = 1.5V/5 \times 100\%/0.3\Omega = 1.0A$$

If, in this state, ATT = H will be as follows :

$$I_{OUT} = 1.0A \times 50\% = 500mA$$



(6) Typical current waveform in each excitation mode when stepping motor parallel input control  
 2-phase excitation (CW mode)

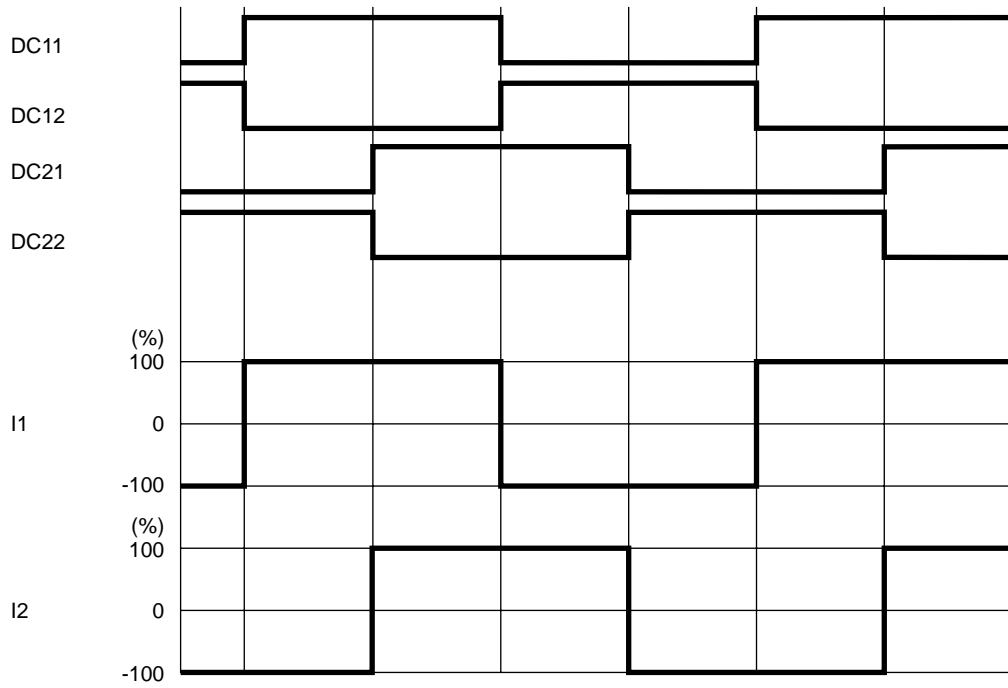

1-2 phase excitation full torque (CW mode)

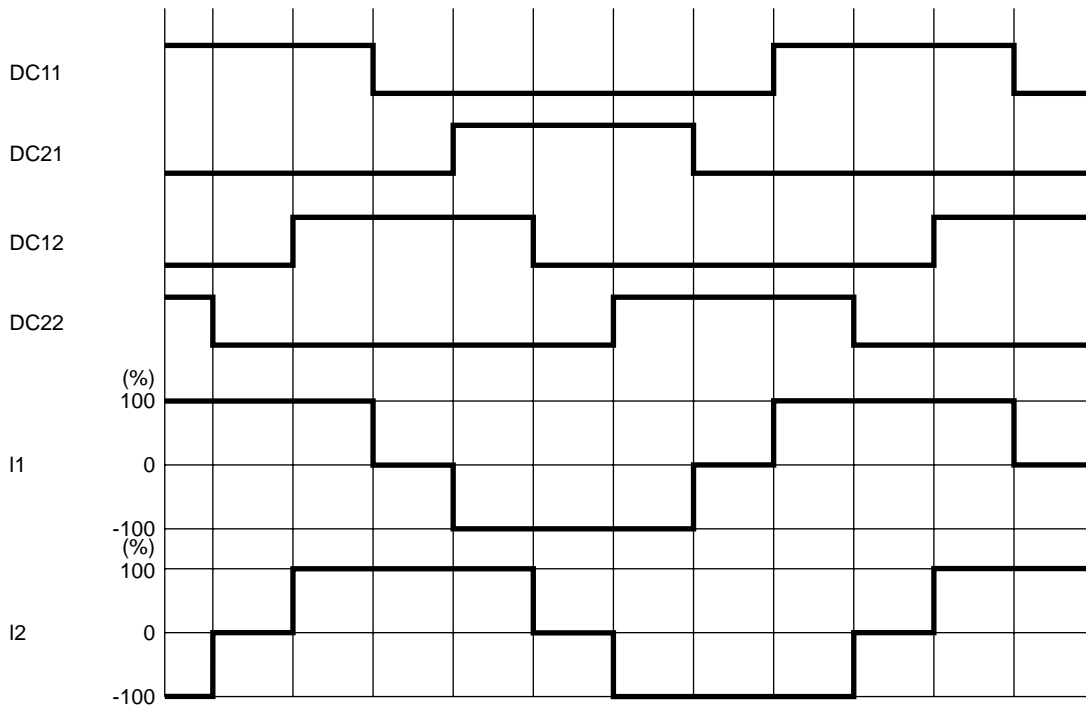

(7) Output short-circuit protection function

This IC incorporates an output short-circuit protection circuit that, when the output has been shorted by an event such as shorting to power or shorting to ground, sets the output to the standby mode and turns on the warning output in order to prevent the IC from being damaged. In the channels 1 and 2 operate independently. (Even if the output of channel 1 has been short-circuited, channel 2 will operate normally.)

(7-1) Output short-circuit protection operation changeover function

Changeover to the output short-circuit protection of IC is made by the setting of EMM pin.

EMM	State
Low or Open	Latch method
High	Auto reset method

(7-2) Latch type

In the latch mode, when the output current exceeds the detection current level, the output is turned OFF, and this state is held.

The detection of the output short-circuited state by the IC causes the output short-circuit protection circuit to be activated.

When the short-circuited state continues for the period of time set using the internal timer (approximately  $2\mu\text{s}$ ), the output in which the short-circuiting has been detected is first set to OFF. After this, the output is set to ON again as soon as the timer latch time ( $T_{cem}$ ) described later has been exceeded, and if the short-circuited state is still detected, all the outputs of the channel concerned are switched to the standby mode, and this state is held.

This state is released by setting ST to low.

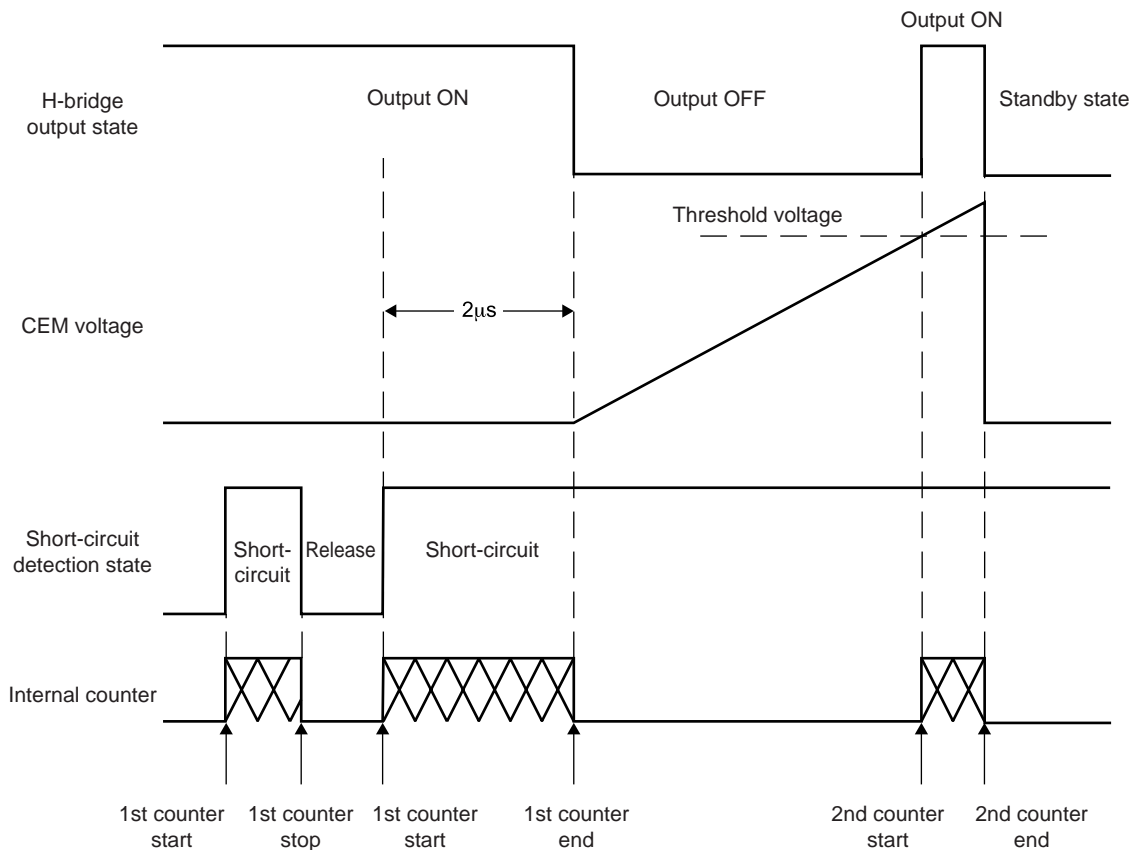



# LV8773

## Application Circuit Example

- Stepping motor driver circuit

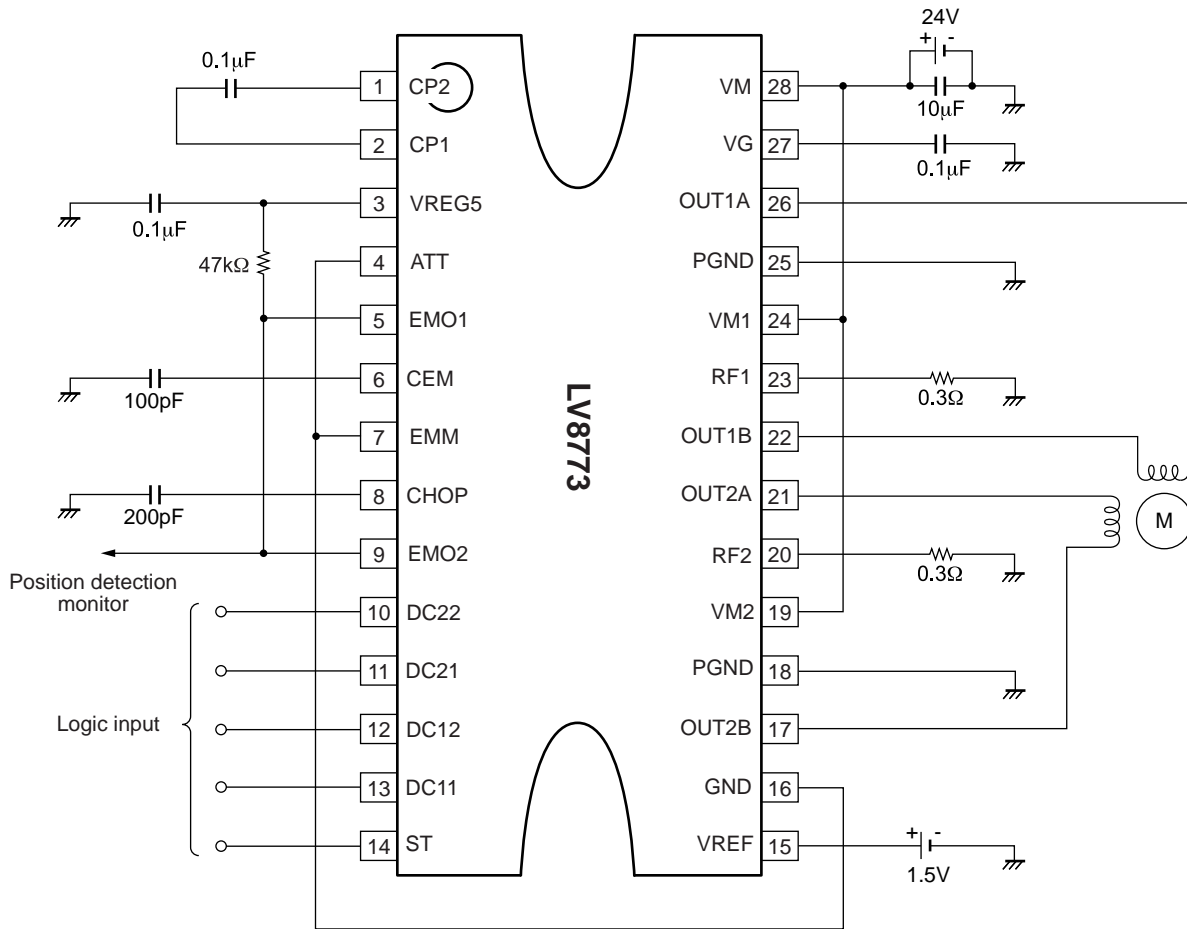

The formulae for setting the constants in the examples of the application circuits above are as follows :

Constant current (100%) setting

When  $V_{REF} = 1.5V$

$$I_{OUT} = V_{REF} / 5 / R_F \text{ resistance} \\ = 1.5V / 5 / 0.3\Omega = 1.0A$$

Chopping frequency setting

$$f_{chop} = I_{chop} / (C_{chop} \times V_{tchop} \times 2) \\ = 10\mu A / (220pF \times 0.5V \times 2) = 45.4kHz$$

Timer latch time when the output is short-circuited

$$T_{cem} = C_{cem} \times V_{tcem} / I_{cem} \\ = 100pF \times 1V / 10\mu A = 10\mu s$$

## LV8773

- DC motor driver circuit (Constant current control function is used.)

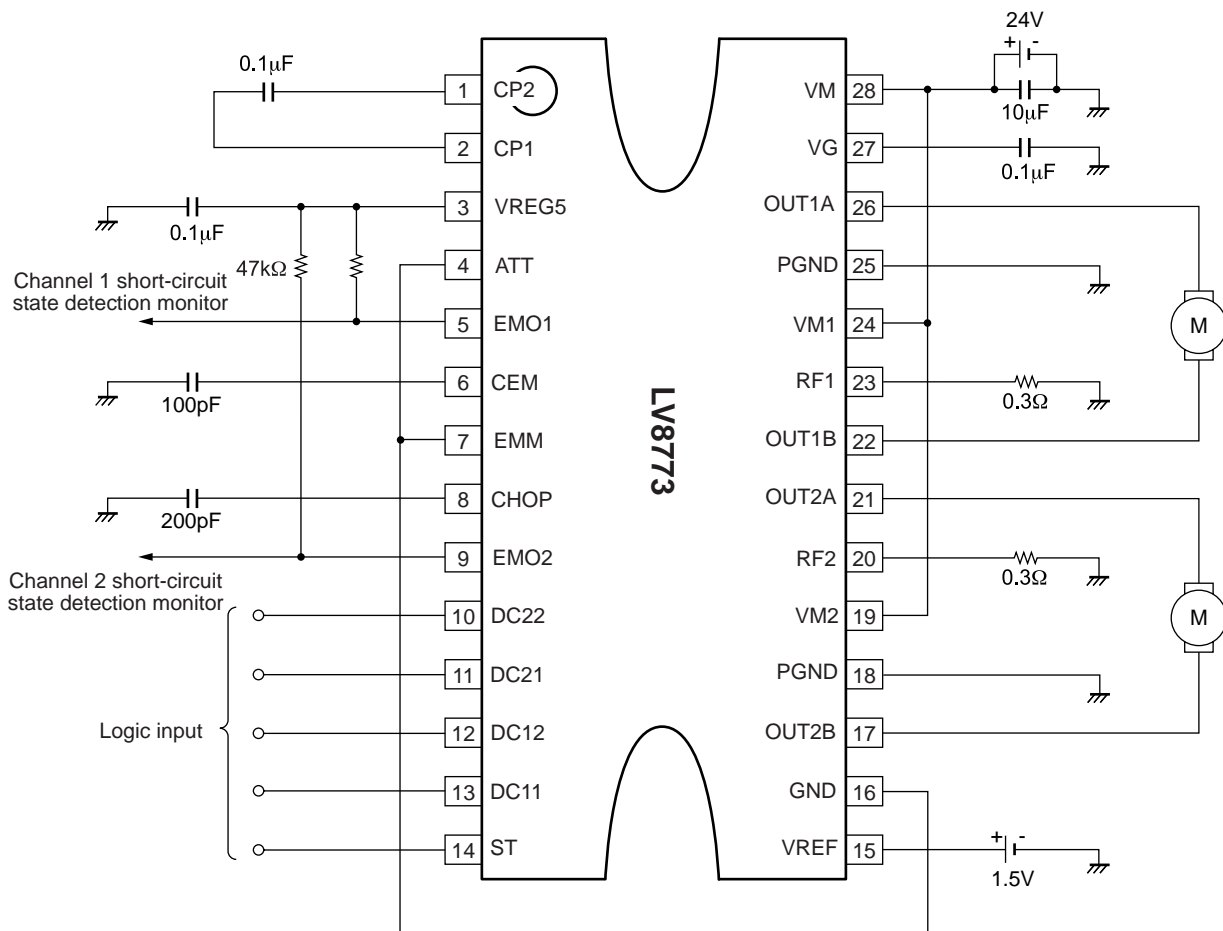

The formulae for setting the constants in the examples of the application circuits above are as follows :

Constant current limit (100%) setting

When  $V_{REF} = 1.5V$

$$I_{limit} = V_{REF} / 5 / R_F \text{ resistance} \\ = 1.5V / 5 / 0.3\Omega = 1.0A$$

Chopping frequency setting

$$F_{chop} = I_{chop} / (C_{chop} \times V_{tchop} \times 2) \\ = 10\mu A / (220pF \times 0.5V \times 2) = 45.4kHz$$

Timer latch time when the output is short-circuited

$$T_{cem} = C_{cem} \times V_{tcem} / I_{cem} \\ = 100pF \times 1V / 10\mu A = 10\mu s$$

- SANYO Semiconductor Co.,Ltd. assumes no responsibility for equipment failures that result from using products at values that exceed, even momentarily, rated values (such as maximum ratings, operating condition ranges, or other parameters) listed in products specifications of any and all SANYO Semiconductor Co.,Ltd. products described or contained herein.
- SANYO Semiconductor Co.,Ltd. strives to supply high-quality high-reliability products, however, any and all semiconductor products fail or malfunction with some probability. It is possible that these probabilistic failures or malfunction could give rise to accidents or events that could endanger human lives, trouble that could give rise to smoke or fire, or accidents that could cause damage to other property. When designing equipment, adopt safety measures so that these kinds of accidents or events cannot occur. Such measures include but are not limited to protective circuits and error prevention circuits for safe design, redundant design, and structural design.
- In the event that any or all SANYO Semiconductor Co.,Ltd. products described or contained herein are controlled under any of applicable local export control laws and regulations, such products may require the export license from the authorities concerned in accordance with the above law.
- No part of this publication may be reproduced or transmitted in any form or by any means, electronic or mechanical, including photocopying and recording, or any information storage or retrieval system, or otherwise, without the prior written consent of SANYO Semiconductor Co.,Ltd.
- Any and all information described or contained herein are subject to change without notice due to product/technology improvement, etc. When designing equipment, refer to the "Delivery Specification" for the SANYO Semiconductor Co.,Ltd. product that you intend to use.
- Information (including circuit diagrams and circuit parameters) herein is for example only; it is not guaranteed for volume production.
- Upon using the technical information or products described herein, neither warranty nor license shall be granted with regard to intellectual property rights or any other rights of SANYO Semiconductor Co.,Ltd. or any third party. SANYO Semiconductor Co.,Ltd. shall not be liable for any claim or suits with regard to a third party's intellectual property rights which has resulted from the use of the technical information and products mentioned above.

This catalog provides information as of June, 2011. Specifications and information herein are subject to change without notice.

Компания «Океан Электроники» предлагает заключение долгосрочных отношений при поставках импортных электронных компонентов на взаимовыгодных условиях!

Наши преимущества:

- Поставка оригинальных импортных электронных компонентов напрямую с производств Америки, Европы и Азии, а так же с крупнейших складов мира;
- Широкая линейка поставок активных и пассивных импортных электронных компонентов (более 30 млн. наименований);
- Поставка сложных, дефицитных, либо снятых с производства позиций;
- Оперативные сроки поставки под заказ (от 5 рабочих дней);
- Экспресс доставка в любую точку России;
- Помощь Конструкторского Отдела и консультации квалифицированных инженеров;
- Техническая поддержка проекта, помощь в подборе аналогов, поставка прототипов;
- Поставка электронных компонентов под контролем ВП;
- Система менеджмента качества сертифицирована по Международному стандарту ISO 9001;
- При необходимости вся продукция военного и аэрокосмического назначения проходит испытания и сертификацию в лаборатории (по согласованию с заказчиком);
- Поставка специализированных компонентов военного и аэрокосмического уровня качества (Xilinx, Altera, Analog Devices, Intersil, Interpoint, Microsemi, Actel, Aeroflex, Peregrine, VPT, Syfer, Eurofarad, Texas Instruments, MS Kennedy, Miteq, Cobham, E2V, MA-COM, Hittite, Mini-Circuits, General Dynamics и др.);

Компания «Океан Электроники» является официальным дистрибьютором и эксклюзивным представителем в России одного из крупнейших производителей разъемов военного и аэрокосмического назначения «JONHON», а так же официальным дистрибьютором и эксклюзивным представителем в России производителя высокотехнологичных и надежных решений для передачи СВЧ сигналов «FORSTAR».



## JONHON

«JONHON» (основан в 1970 г.)

Разъемы специального, военного и аэрокосмического назначения:

(Применяются в военной, авиационной, аэрокосмической, морской, железнодорожной, горно- и нефтедобывающей отраслях промышленности)

«FORSTAR» (основан в 1998 г.)

ВЧ соединители, коаксиальные кабели, кабельные сборки и микроволновые компоненты:

(Применяются в телекоммуникациях гражданского и специального назначения, в средствах связи, РЛС, а так же военной, авиационной и аэрокосмической отраслях промышленности).



Телефон: 8 (812) 309-75-97 (многоканальный)

Факс: 8 (812) 320-03-32

Электронная почта: [ocean@oceanchips.ru](mailto:ocean@oceanchips.ru)

Web: <http://oceanchips.ru/>

Адрес: 198099, г. Санкт-Петербург, ул. Калинина, д. 2, корп. 4, лит. А